

Bell Atlantic - Pennsylvania, Inc.
1717 Arch Street, 32N
Philadelphia, PA 19103
Tel: (215) 963-6001
Fax: (215) 563-2658

Julia A. Conover
Vice President and General Counsel
Law Department

ORIGINAL



October 15, 1998

A-310651

VIA FEDERAL EXPRESS

RECEIVED

James J. McNulty, Secretary
Pennsylvania Public Utility Commission
North Street & Commonwealth Avenue
North Office Building - Room B20
Harrisburg, PA 17120

OCT 15 1998

KJR

PA PUBLIC UTILITY COMMISSION
SECRETARY'S BUREAU

RE: Joint Petition of Bell Atlantic - Pennsylvania, Inc. and Service Electric Telephone Company for Approval of an Interconnection Agreement

Dear Mr. McNulty:

Enclosed please find an original and three (3) copies of the Joint Petition of Bell Atlantic - Pennsylvania, Inc. ("BA-PA"), and Service Electric Telephone Company for Approval of an Interconnection Agreement between BA-PA and Service Electric Telephone Company.

Please date stamp the enclosed additional copy and return it to me in the enclosed self-addressed, stamped envelope.

Very truly yours,

Julia A. Conover
Julia A. Conover

JAC/dc

Enclosure

cc: James Troup, Esq. (Via Federal Express)
Attached Certificate of Service

DOCUMENT
FOLDER

40

ORIGINAL

BEFORE THE PENNSYLVANIA PUBLIC UTILITY COMMISSION

**JOINT PETITION OF
BELL ATLANTIC - PENNSYLVANIA, INC.
AND SERVICE ELECTRIC TELEPHONE
COMPANY OF AN INTERCONNECTION
AGREEMENT UNDER SECTION 252(e) OF
THE TELECOMMUNICATIONS ACT OF 1996.**

)
)
) PUC Docket No. **A-310651**
)
)
)

RECEIVED

OCT 15 1998

JOINT PETITION

**PA PUBLIC UTILITY COMMISSION
SECRETARY'S BUREAU**

Bell Atlantic - Pennsylvania, Inc. ("BA-PA") and Service Electric Telephone Company ("Service Electric") respectfully submit for the Commission's approval, pursuant to Sections 251 and 252 of the Telecommunications Act of 1996 (the "1996 Act")¹, the attached Interconnection Agreement dated August 27, 1998 (the "Agreement"). The Agreement provides for the interconnection of the two companies' networks and makes available to Service Electric access to unbundled network elements, wholesale telecommunications services, and ancillary services offered by BA-PA. The Agreement is an important step towards comprehensive local competition in Pennsylvania as envisioned by the General Assembly when it authorized local telephone service competition in Chapter 30 and by Congress in the 1996 Act. BA-PA and Service Electric, therefore, respectfully request that the Commission act within the 90 days specified by the 1996 Act and approve the Agreement.

**DOCKETED DOCUMENT
OCT 26 1998
FOLDER**

¹Citations herein to the 1996 Act should be construed as references to sections of the Communications Act of 1934 as amended by the 1996 Act.

In support of this request, BA-PA and Service Electric state as follows:

THE PARTIES

1. BA-PA is an incumbent local exchange carrier authorized to provide local exchange telephone service in Pennsylvania.
2. Service Electric is a competitive local exchange carrier that has been granted authority to provide local telephone service in Pennsylvania.

THE AGREEMENT

3. Service Electric has exercised its right under Section 252 (i) of the 1996 Act to opt into the BA-PA/MCImetro Interconnection Agreement dated July 8, 1997 which the Commission approved on September 3, 1997 in Docket No. A-310236F0002. The BA-PA/ Service Electric agreement is based on that approved agreement which was revised as of July 29, 1997.

4. The Agreement sets forth the terms, conditions and prices under which BA-PA and Service Electric will offer and provide network interconnection, reciprocal call termination, access to network elements, ancillary network services, and wholesale telecommunications services available for resale to each other within each Local Access and Transport Area ("LATA") in which they both operate in Pennsylvania. The Agreement is an integrated package that reflects a balance of many interests and concerns critical to both parties.

COMPLIANCE WITH THE 1996 ACT

6. The Agreement satisfies the requirements for Commission approval pursuant to Section 252(e)(2)(A) of the 1996 Act, which provides as follows:

The State commission may only reject ... an agreement (or any portion thereof) adopted by negotiation under subsection (a) if it finds that--

(i) the agreement (or portion thereof) discriminates against a telecommunications carrier not a party to the agreement; or

(ii) the implementation of such agreement or portion is not consistent with the public interest, convenience, and necessity[.]

7. First, the Agreement does not discriminate against any other telecommunications carrier, as required by Section 252(e)(2)(a)(i). To the contrary, BA-PA is willing to make the interconnection, unbundling and resale arrangement contained in the Agreement available to any other telecommunications carrier certificated to provide local telephone service in Pennsylvania. Nonetheless, other carriers are not bound by the Agreement and remain free to negotiate independently with BA-PA pursuant to Section 252 of the 1996 Act.

8. Second, the Agreement is consistent with the public interest, convenience, and necessity, as required by Section 252(e)(2)(a)(ii). It is an important step towards allowing Service Electric to compete with BA-PA as a facilities-based local telephone service carrier for both residential and business customers. The Agreement will also be available to all local exchange competitors under Section 252(i) of the 1996 Act.

APPROVAL OF THE AGREEMENT

9. The parties respectfully request that the Commission expedite its review of the Agreement to facilitate implementation of competition in the local exchange market. Although under Section 252(e)(4) of the 1996 Act, the Commission has 90 days to approve or reject the Agreement, the parties request that the Commission act sooner than that date if at all possible.

WHEREFORE, BA-PA and Service Electric respectfully request that the Commission approve the attached interconnection agreement pursuant to Section 252(e) of the 1996 Act.

Respectfully submitted,

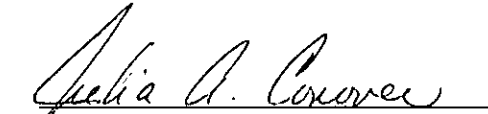

Julia A. Conover
Christopher Arfaa
Bell Atlantic - Pennsylvania, Inc.
1717 Arch Street, 32N
Philadelphia, PA 19103
(215) 963-6001

Attorneys For
Bell Atlantic -Pennsylvania, Inc.

Of Counsel
Jack H. White

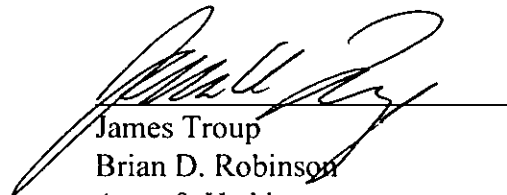

James Troup
Brian D. Robinson
Arter & Hadden
1801 K Street, NW
Suite 4000
Washington, DC 20006-1301
(202) 775-7100

Attorney for
Service Electric Telephone Company

DATED: October 15, 1998

RECEIVED

OCT 15 1998

PA PUBLIC UTILITY COMMISSION
SECRETARY'S BUREAU

A-310651

**INTERCONNECTION AGREEMENT UNDER SECTIONS 251 AND 252 OF THE --
TELECOMMUNICATIONS ACT OF 1996**

Dated as of August 27, 1998

by and between

BELL ATLANTIC - PENNSYLVANIA, INC.

and

SERVICE ELECTRIC TELEPHONE COMPANY

INTERCONNECTION AGREEMENT UNDER SECTIONS 251 AND 252 OF THE TELECOMMUNICATIONS ACT OF 1996

This Interconnection Agreement (this "Agreement"), under Sections 251 and 252 of the Telecommunications Act of 1996 (the "Act"), is effective as of the 27th day of August, 1998 (the "Effective Date"), by and between Bell Atlantic - Pennsylvania, Inc. ("BA"), a Pennsylvania corporation, and Service Electric Telephone Company ("Service Electric"), a Pennsylvania limited liability company (each a "Party" and, collectively, the "Parties").

WHEREAS, Service Electric has requested that BA make available to Service Electric interconnection, service and unbundled network elements upon the same terms and conditions as provided in the Interconnection Agreement (and amendments thereto) between MCImetro Access Transmission Services, Inc. and BA, dated as of July 8, 1997, for the Commonwealth of Pennsylvania, approved by the Commission under Section 252 of the Act (the "Separate Agreement") and attached as Appendix 1 hereto; and

WHEREAS, BA has undertaken to make such terms and conditions available to Service Electric hereby only because and, to the extent required by, Section 252(i) of the Act.

NOW, THEREFORE, in consideration of the mutual provisions contained herein and other good and valuable consideration, the receipt and sufficiency of which are hereby acknowledged, Service Electric and BA hereby agree as follows:

1.0 Incorporation of Appendices by Reference

1.1 Except as expressly stated herein, the terms and conditions of the Appendices hereto (including, without limitation, Appendix 1 hereto with all Schedules and Exhibits thereto) are incorporated by reference in their entirety herein and form an integral part of this Agreement.

1.2 References in Appendix 1 hereto to MCImetro Access Transmission Services, Inc. or to MCI or to MCImetro shall for purposes of this Agreement be deemed to refer to Service Electric.

1.3 References in Appendix 1 hereto to the "Effective Date", the date of effectiveness thereof and like provisions shall for purposes of this Agreement be deemed to refer to the date first written above. Unless terminated earlier in accordance with the terms of Appendix 1 hereto, this Agreement shall continue in effect until the Separate Agreement is terminated.

1.4 All notices, affidavits, exemption-certificates or other communications to Service Electric under Section 14 of Appendix 1 hereto shall be sent to the following address:

Arter & Hadden
Attention: James Troup
1801 K Street, N.W., Suite 4000
Washington, D.C. 20006-1301
Facsimile: 202/857-0172

1.5 All notices, affidavits, exemption-certificates or other communications to BA under Section 14 of Appendix 1 hereto shall be sent to the following address:

President - Telecommunications Industry Services
Bell Atlantic Corporation
1095 Avenue of the Americas
40th Floor
New York, New York 10036
Facsimile: 703/974-2183

1.6 The rates, charges and other terms set forth in Appendix 2 hereto shall replace and supersede in their entirety the rates, charges and other terms set forth in Attachment 1 (Price Schedule) to Appendix 1 hereto.

2.0 Clarifications

2.1 The Parties agree that if any judicial or regulatory authority of competent jurisdiction determines (or has determined) that BA is not required to furnish any service or item or provide any benefit to telecommunications carriers otherwise required to be furnished or provided to Service Electric hereunder, then BA may, at its sole option, avail itself of any such determination by providing written notice thereof to Service Electric.

2.2 Notwithstanding anything to the contrary contained in this Agreement, the Parties agree that BA shall only be required to provide Combinations and any services related to its provision of Combinations to the extent (a) required by Applicable Law or (b) mutually agreed to by the Parties in writing after the date hereof.

2.3 For the avoidance of doubt, the Parties acknowledge and agree that the term "Dedicated Transport", as described in Section 10 of Attachment III of Appendix 1 hereto, does not include within its definition transmissions between locations that include subscriber premises.

2.4 The entry into, filing and performance by BA of this Agreement does not in any way constitute a waiver by BA of any of the rights and remedies it may have to seek review of any of the provisions of the Separate Agreement, or to petition the Commission, other administrative body or court for reconsideration or reversal of any determination made by any of them, or to seek review in any way of any portion of this Agreement in connection with Service Electric's election under Section 252(i) of the Act.

IN WITNESS WHEREOF, the Parties hereto have caused this Agreement to be executed as of this 27th day of August, 1998.

SERVICE ELECTRIC TELEPHONE
COMPANY

BELL ATLANTIC-
PENNSYLVANIA, INC.

By: William D. George II

By: Jacob J. Goldberg

Printed: WILLIAM D. GEORGE II

Printed: Jacob J. Goldberg

Title: PRESIDENT

Title: President - Telecom Industry Services

APPENDIX 2

BELL ATLANTIC - PENNSYLVANIA, INC.

DETAILED SCHEDULE OF ITEMIZED CHARGES**A. BA SERVICES, FACILITIES, AND ARRANGEMENTS:¹**

| <u>Service or Element Description:</u> | <u>Recurring Charges:</u> | <u>Non-Recurring Charge:</u> |
|---|---------------------------|------------------------------|
| I. Local Call Termination² | | |
| Traffic Delivered at BA End Office | \$.001864/MOU | Not Applicable |
| Traffic Delivered at BA Tandem or Local Serving Wire Center | \$.002902/MOU | Not Applicable |

¹ Unless a citation is provided to a generally applicable BA tariff, all listed rates and services available only to Service Electric when purchasing these services for use in the provision of Telephone Exchange Service, and apply only to Local Traffic and local Ancillary Traffic. BA rates and services for use by Service Electric in the carriage of Toll Traffic shall be subject to BA's tariffs for Exchange Access Service. Adherence to these limitations is subject to a reasonable periodic audit by BA.

As applied to wholesale discount rates, unbundled Network Elements or call transport and/or termination of Local Traffic purchased for the provision of Telephone Exchange Service or Exchange Access, the rates and charges set forth in Exhibit A shall apply until such time as they are replaced by new rates as may be approved or allowed into effect by the Commission from time to time pursuant to the FCC Regulations, subject to a stay or other order issued by any court of competent jurisdiction. At such time(s) as such new rates have been approved or allowed into effect by the Commission, the Parties shall amend Exhibit A to reflect the new approved rates.

² See note 6 regarding measurement and calculation of local traffic termination charges.

Service or Element Description:

Recurring Charges:

Non-Recurring Charge:

II. Unbundled Transport

A. Dedicated Transport

Voice Grade/DS-0

\$10.37/Month &
\$.03/Mile/Month

Voice Grade/DS-0,
DS-1, DS-3 & DDS:

DS-1

\$37.66/Month &
\$.66/Mile/Month

\$1.05/Service Order,
\$353.70/Initial
Facility &

DS-3

\$526.72/Month &
\$18.66/Mile/Month

\$24.00/Additional
Facility (if purchased
when initial facility
ordered)

DDS

\$10.74/Month &
\$.04/Mile /Month

B. Common Transport

Tandem Switching

\$.000836/MOU

Not Applicable

Transport Fixed

\$.000152/MOU

Not Applicable

Transport Per Mile

\$.000004/MOU

Not Applicable

Service or Element Description:

Recurring Charges:

Non-Recurring Charge:

II. Unbundled Transport (Continued)
C. Entrance Facilities

All:
\$1.05/Service Order plus installation charges for each initial and additional facility purchased at the time of order:

| | | |
|---------------------------------------|-----------------|--|
| 2Wire Voice Grade Channel Termination | \$16.78/Month | \$497.06/Initial & \$289.47/Additional |
| 4Wire Voice Grade Channel Termination | \$33.76/Month | \$498.73/Initial & \$290.02/Additional |
| DS-1 to Voice Grade Multiplexing | \$77.83/Month | \$548.06/Initial & \$548.06/Additional |
| DS-1 Channel Termination | \$180.59/Month | \$668.37/Initial & \$331.87/Additional |
| DS-3 to DS-1 Multiplexing | \$257.61/Month | \$548.06/Initial & \$548.06/Additional |
| DS-3 Channel Termination | \$1059.65/Month | \$668.37/Initial & \$331.87/Additional |

D. Digital Cross-Connect System

| | | |
|---------------------------------|--------------------|--------------------------------------|
| Service Establishment | Not Applicable | \$1890.82 |
| Database Modification | Not Applicable | \$148.68/Modification Request |
| Reconfiguration by BA personnel | Not Applicable | \$31.98 Programming Charge/Half Hour |
| DS-0 Cross-Connect | \$20.54/Port/Month | \$26.17/Port |
| DS-1 Cross-Connect | \$71.92/Port/Month | \$32.71/Port |

Service or Element Description:

Recurring Charges: **Non-Recurring Charge:**

II. Unbundled Transport (Continued)

E. Mid-span meet arrangements

To be charged in accordance with the requirements of Section 4.3 of the Agreement

F. Transit Arrangements (for Interconnections between Service Electric and Carriers other than BA)

Tandem Switching

\$.000836/MOU

Per Section II. above and V., as applicable

Switched Transport

\$.000152/MOU

\$.000004/MOU/Mile

III. Unbundled Switching³

A. Local Switching Ports

POTS/PBX/Centrex

\$2.67/Port/Month

\$1.05/Service Order Per Port:

\$2.97/Installation

\$1.32/Disconnect

ISDN (BRI)

\$10.28/Port/Month

\$1.05/Service Order Per Port:

\$2.97/Installation

\$1.32/Disconnect

ISDN (PRI)

\$135.13/Port/Month

\$1.05/Service Order Per Port:

\$113.36/Installation

\$1.32/Disconnect

Public/Semi-Public

\$3.52/Port/Month

\$1.05/Service Order Per Port:

\$2.97/Installation

\$1.32/Disconnect

DID

\$5.98/Port/Month

\$1.05/Service Order Per Port:

\$692.07/Installation

\$1.32/Disconnect

B. Tandem Switching Usage

\$.0008360/MOU

Not Applicable

C. Local Switching Usage

Originating With Vertical Features

\$.011067/MOU

Not Applicable

Terminating With Vertical Features

\$.006143/MOU

Not Applicable

³ In addition to the recurring and non-recurring rates set forth herein for unbundled switching elements, BA may levy upon purchaser of such elements any access charges (or portion thereof) permitted by Applicable Laws.

Service or Element Description:

Recurring Charges:

Non-Recurring Charge:

IV. Unbundled Loops

POTS (Analog 2-Wire)

Density Cell:
1 - \$11.52/Month
2 - \$12.71/Month
3 - \$16.12/Month
4 - \$23.11/Month

Service Order: \$1.05
Installation:
If premises visit not required - \$2.97 initial and each additional loop; Not Applicable if existing loop & port together

If premises visit required - \$66.85, initial loop; \$22.59, additional loop

Disconnect:
\$1.32 per loop

ISDN

Density Cell:
1 - \$13.16/Month
2 - \$14.35/Month
3 - \$17.75/Month
4 - \$24.74/Month

Service Order: \$1.05
Installation:
If premises visit not required - \$12.91 initial and each additional loop; Not Applicable if existing loop & port together

If premises visit required - \$76.78, initial loop; \$32.52, additional loop

Disconnect:
\$1.32 per loop

Service or Element Description:

Recurring Charges:

Non-Recurring Charge:

IV. Unbundled Loops (Continued)

Customer Specified Signaling - 2 Wire

Density Cell:

1 - \$11.52/Month

2 - \$12.71/Month

3 - \$16.12/Month

4 - \$23.11/Month

Service Order: \$1.05

Installation:

If premises visit not required - \$2.97

initial and each

additional loop; Not

Applicable if existing

loop & port together

If premises visit

required - \$66.85.

initial loop; \$22.59,

additional loop

Disconnect:

\$1.32 per loop

Coordinated Cutover:

If premises visit not

required - \$3.24 per

order

If premises visit

required - \$12.10 per

order

Designed Circuit:

\$40.93 per order

Service or Element Description:

Recurring Charges:

Non-Recurring Charge:

IV. Unbundled Loops (Continued)

Customer Specified Signaling - 4 Wire

Density Cell:

- 1 - \$22.40/Month
- 2 - \$26.36/Month
- 3 - \$33.03/Month
- 4 - \$45.47/Month

Service Order: \$1.05

Installation:

If premises visit not required - \$2.97 initial and each additional loop; Not Applicable if existing loop & port together

If premises visit required - \$66.85. initial loop; \$22.59. additional loop

Disconnect:

\$1.32 per loop

Coordinated Cutover:

If premises visit not required - \$3.24 per order

If premises visit required - \$12.10 per order

Designed Circuit:

\$40.93 per order

Service or Element Description:

Recurring Charges:

Non-Recurring Charge:

IV. Unbundled Loops (Continued)

DS1

Density Cell:

- 1 - \$132.51/Month
- 2 - \$139.37/Month
- 3 - \$168.59/Month
- 4 - \$252.46/Month

Service Order: \$1.05

Installation:

If premises visit not required - \$2.97 initial and each additional loop; Not Applicable if existing loop & port together

If premises visit required - \$66.85, initial loop; \$22.59, additional loop

Disconnect:

\$1.32 per loop

Coordinated Cutover:

If premises visit not required - \$3.24 per order

If premises visit required - \$12.10 per order

Designed Circuit:

\$40.93 per order

2 Wire ADSL Loops

TBD

TBD

2 Wire & 4 Wire HDSL Loops

TBD

TBD

V. Collocation Cross-Connection

A. Voice Grade Loop

Physical DS0 CO side to equipment

\$.41/Month

Not Applicable

Virtual DS0 with RFT CO side MDF to equipment

\$1.20/Month

Not Applicable

Virtual DS1 with EDSX (1DS1 + 24 DS0's with IDLC)

\$60.21/Month

Both:

\$1.05/Service Order
\$544.36/Initial

Virtual DS1 with CFA (24DS0s with IDLA)

\$44.08/Month

Installation &
\$210.46/Additional
Installations

Service or Element Description:

Recurring Charges:

Non-Recurring Charge:

V. Collocation Cross-Connection (Continued)

B. Other

| | | |
|--------------|---------------|--|
| Physical DS3 | \$84.27/Month | <u>All:</u> |
| Physical DS1 | \$15.72/Month | \$1.05/Service Order \$481.36/Initial |
| Virtual DS3 | \$88.81/Month | Installation & \$194.71/Additional |
| Virtual DS1 | \$16.12/Month | Installations |

VI. Time and Materials

| | | |
|--|--------------------------------------|---|
| Special Construction | As applicable per BA-PA PUC 1 sec. 9 | |
| Service Technician (service work on unbundled loops outside of the Central Office) | Not Applicable | \$1.05/Service Order \$26.24/Premises Visit \$12.10 Labor Charge/ Quarter Hour After First Quarter Hour |
| Central Office Technician | Not Applicable | .\$1.05/Service Order \$10.42 Labor Charge/ Quarter Hour or Fraction Thereof |

VII. Signaling and Databases

A. STP Port

| | | |
|-------------|------------------|--|
| Termination | \$640.02/Month | \$94.15/Port |
| Access | \$.47/Mile/Month | \$1.05/Service Order \$274.06/Initial Facility & \$24.01/Additional Facility |

B. 800/888 Database

| | | |
|----------------|-----------------|----------------|
| Basic Query | \$.000835/Query | Not Applicable |
| Vertical Query | \$.000343/Query | Not Applicable |

Service or Element Description:**Recurring Charges:** **Non-Recurring Charge:****VII. Signaling and Databases (Continued)****C. LIDB Validation**

| | | |
|---|-----------------|----------------------------------|
| LIDB Point Codes | Not Applicable | \$85.84/Point Code |
| Calling Card | \$.015542/Query | Not Applicable |
| Billed Number Screening | \$.015542/Query | Not Applicable |
| Storage of Service Electric's Data in LIDB Database | Not Applicable | \$1,469.92 Service Establishment |

D. AIN Service Creation (ASC) Service**1. Developmental Charges**

| | | |
|------------------------------|---------------------|----------------|
| Service Establishment | Not Applicable | \$884.08 |
| Service Creation Access Port | \$123.86/Port/Month | Not Applicable |
| Service Creation Usage | | |
| a. Remote Access | \$1,328.47/Day | Not Applicable |
| b. On-Premise | \$1,328.47/Day | Not Applicable |
| Certification & Testing | \$76.99/Hour | Not Applicable |
| Help Desk Support | \$.81.48/Hour | Not Applicable |

2. Service Charges

| | | |
|--|----------------|-------------------------------|
| Subscription Charge | \$5.44/Month | Not Applicable |
| Database Queries | | |
| a. Network Query | \$.0007/Query | Not Applicable |
| b. Service Electric Network Query | \$.0007/Query | Not Applicable |
| c. Service Electric Switch Query | \$.0007/Query | Not Applicable |
| Trigger Charge | | |
| a. Line Based | \$.0010/Query | Not Applicable |
| b. Office Based | \$.0010/Query | Not Applicable |
| Utilization Element | \$.0003/Query | Not Applicable |
| Service Activation Charge | | |
| a. Network Service Activation | Not Applicable | \$8.37/Service Activated/Line |
| b. Service Electric Network Service Activation | Not Applicable | \$8.37/Service Activated/Line |

Service or Element Description:

Recurring Charges:

Non-Recurring Charge:

| | | |
|---|----------------|-------------------------------|
| c. Service Electric Switch Service Activation | Not Applicable | \$8.37/Service Activated/Line |
|---|----------------|-------------------------------|

D. AIN Service Creation (ASC) Service (Continued)

Service Modification

| | | |
|-------------|--------------------|----------------|
| DTMF Update | \$.1080/Occurrence | Not Applicable |
|-------------|--------------------|----------------|

| | | |
|---------------------------|---------------------|----------------|
| Switch Based Announcement | \$.005/Announcement | Not Applicable |
|---------------------------|---------------------|----------------|

VIII. Directory Listings & Books

| | | |
|---|----------------|----------------|
| Primary Listing (on initial UNE service order). For each residence telephone number, two (2) listings in the White Page directory are provided. For each business telephone number listed (except numbers of Centrex or Centrex-like services or indialing service station lines) one (1) listing is provided in the White Page Directory and one (1) listing in the Yellow Page directory of the type provided to BA-PA end user business customers for which no, specific charge applies. | Not Applicable | Not Applicable |
|---|----------------|----------------|

| | | |
|--|---|--|
| Other Tariffed Listing Services (For listings ordered in excess of the primary listings provided or other listing types, or listings ordered at a time other than initial UNE service order, or listings ordered not associated with a UNE service order.) | Retail rates less wholesale discount. For retail rates see BA-PA tariff No. 1 sec. 5.B. | |
|--|---|--|

| | | |
|--|--|--|
| Books & delivery (annual home area directories only) | No charge for normal numbers of books delivered to end users; bulk deliveries to Service Electric per separate arrangement | |
|--|--|--|

Service or Element Description:

Recurring Charges:

Non-Recurring Charge:

IX. Operator Services/Directory Assistance

| | | |
|---|---|--|
| Direct Access | \$.0342/Query | \$32,135.28/Link & \$15,206.81 Service Establishment |
| Directory Assistance | \$.3664/Call | Not Applicable |
| Directory Transport | | |
| Tandem Switching | \$.000730/Call | Not Applicable |
| Tandem Switched Transport | \$.000132/Call & \$.000003/Mile/Call | Not Applicable |
| Operator Services - Live | \$.01280/Operator Work Second | Not Applicable |
| Operator Services - Automated | \$.00158/Automated Work Second | Not Applicable |
| Branding for Directory Assistance and/or Operator Services | Not Applicable | \$1,358.62/Message |
| Carrier-to-Carrier LSV/VCI Requests | \$.01280/Operator Work Second | Not Applicable |

Service or Element Description:**Recurring Charges:****Non-Recurring Charge:****X. Access to Operation Support Systems****A. Pre-Ordering**

\$.22/Query

Not Applicable

B. Ordering

\$3.34/Transaction

Not Applicable

C. Provisioning

Included in Ordering

Not Applicable

D. Maintenance & Repair**1. ECG Access**

\$.22/Query

Not Applicable

2. EB/OSI Access

\$1.16/Trouble Ticket

Not Applicable

E. Billing**1. CD-ROM**

\$246.59/CD-ROM

Not Applicable

2. Daily Usage File**a. Existing Message Recording**

\$.000258/Message

Not Applicable

b. Delivery of DUF

Data Tape

\$17.18/Tape

\$61.39/Programming Hour

Network Data Mover

\$.000094/Message

Not Applicable

CMDS

\$.000094/Message

\$61.39/Programming Hour

c. DUF Transport

9.6 kb Communications Port

\$10.24/Month

\$7,437.36/Port

56 kb Communications Port

\$28.29/Month

\$30,778.91/Port

256 kb Communications Port

\$28.29/Month

\$51,236.88/Port

T1 Communications Port

\$359.31/Month

\$182,827.99/Port

Line Installation

Not Applicable

\$61.39/Programming Hour/Port

Port Set-up

Not Applicable

\$9.85/Port

Network Control Programming Coding

Not Applicable

\$61.39/Programming Hour/Port

XI. Exchange Access Service

Interstate

Per BA-FCC tariff number 1

Intrastate

Per BA-PA tariff number 302

Service or Element Description:

Recurring Charges: Non-Recurring Charge:

XII. Number Portability

Interim (using RCF)

\$1.50/Month/Ported
Number

\$5.00/Service Order
\$4.00/Installation/No.
at same location

Permanent

Per permanent funding mechanism when
established.

Access pass-through to number portability
purchaser

In accordance with Section 14.5 of Agreement

XIII. 911/E911

Transport

Per section II above.

Data Entry and Maintenance

No Charge

XIV. Poles Conduits & ROW

Per contract rates pursuant to 47 U.S.C. sec.
224

Illustrative:

Duct: \$5.45/Foot/Year

Pole: \$3.98/Attachment/Year

XV. Network Interface Device (NID)

\$.68/Month

Not Applicable

**XVI. Access to Telephone Numbers (NXX
codes issued per ICCF Code Administration
Guidelines)**

No Charge

XVII. Local Dialing Parity

No Charge

XVIII. Customized Routing

To Reseller Platform

\$.142360/Line.Month \$3.84/Line

To BA Platform for Re-Branding

\$.08330/Call \$3.84/Line

Customized Routing Transport

Per section II above.

Service or Element Description:

Recurring Charges: Non-Recurring Charge:

XIX. Wholesale Discount for Resale of Retail Telecommunications Services⁴

| | |
|---|--|
| Resale of retail services if Service Electric provides own operator services platform | 20.69% |
| Resale of retail services if Service Electric uses Bell Atlantic operator services platform | 18.43% |
| Pennsylvania Gross Receipts Tax Discount | Discount as per BA-PA PUC 1 sec. 1.8.1 tariff. |

⁴ Excludes telecommunications services designed primarily for wholesale, such as switched and special exchange access service, and, subject to Section 12 of the Agreement, the following additional arrangements that are not subject to resale: limited duration (90 days or less) promotional offerings, public coin telephone service, and technical and market trials. Taxes shall be collected and remitted by the reseller and BA in accordance with legal requirements and as agreed between the Parties. Surcharges (e.g., 911, telecommunications relay service, universal service fund) shall be collected by the reseller and either remitted to the recipient agency or NECA, or passed through to BA for remittance to the recipient agency or NECA, as appropriate and agreed between the Parties. End user common line charges shall be collected by the reseller and remitted to BA.

Pending establishment of mechanized billing procedures adapted to resale, BA will apply the wholesale discount for resale as a "bottom-of-the-bill" discount rate and will utilize a "true-up" process to correct possible inadvertent application of the wholesale discount to the exclusions identified herein and to reflect other adjustments as the Companies agree.

B. Service Electric SERVICES, FACILITIES, AND ARRANGEMENTS:

| <u>Service or Element Description:</u> | <u>Recurring Charges:</u> | <u>Non-Recurring Charge:</u> |
|---|--|--|
| I. Local Call Termination⁵ | | |
| Traffic Delivered at End Office | \$.001864/MOU | Not Applicable |
| Traffic Delivered at Tandem or Local Serving Wire Center | \$.002902/MOU | Not Applicable |
| II. Number Portability | | |
| Interim | \$1.50/Month/Ported Number | \$5.00/Service Order \$4.00/Installation/No. at same location |
| Permanent | Per permanent funding mechanism when established. | |
| Access pass-through to number portability purchaser | In accordance with Section 14.5 of Agreement | |
| III. Exchange Access Service | | |
| Interstate | Per Service Electric FCC exchange access tariff. | |
| Intrastate | Per Service Electric PA tariff exchange access tariff. | |
| IV. Local Dialing Parity | No Charge | |
| V. All Other Service Electric Services Available to BA for Purposes of Effectuating Local Exchange Competition | Available at Service Electric's tariffed or otherwise generally available rates, not to exceed BA rates for equivalent services available to Service Electric. | |
| VI. Other Services | \$.03/Call | No Charge |
| Information Service Billing Fee | | |

⁵ See note 6 regarding measurement and calculation of local traffic termination charges.

6 LOCAL TRAFFIC TERMINATION RATES

A. Charges by BA

- (a) Traffic delivered to BA Local Serving Wire Center ("LSWC") or BA Access Tandem: \$.002902 per mou.
(b) Traffic delivered directly to terminating BA End Office: \$.001864 per mou.

B. Charges by Service Electric

1. Single-tiered interconnection structure:

Service Electric's rates for the termination of BA's Local Traffic under the single-tiered interconnection structure shall be recalculated once each year on each anniversary of the Effective Date (the "Rate Determination Date"). The methodology for recalculating the rates is as follows:

LSWC/Access Tandem Minutes = Total minutes of use of Local Traffic delivered by Service Electric to the BA LSWC or BA Access Tandem for most recent billed quarter.

End Office Minutes = Total minutes of use Local Traffic delivered by Service Electric directly to the terminating BA End Office for most recent billed quarter.

Total Minutes = Total minutes of use of Local Traffic delivered by Service Electric to BA for most recent billed quarter.

Service Electric Charge at the Service Electric-IP =

$$\frac{(\text{LSWC/Access Tandem Minutes} \times \$0.002902) + (\text{End Office Minutes} \times \$0.001864)}{\text{Total Minutes}}$$

For the first-year after the Effective Date, the Service Electric charge shall be calculated based on the traffic data of the quarter immediately preceding such Effective Date, or if no such traffic exists, on the proportion of local call termination trunks to BA End Offices and to BA LSWC/Access Tandems.

2. Multiple-tiered interconnection structure (if offered by Service Electric to any carrier)

- (a) Local Traffic delivered to Service Electric LSWC or Service Electric Access Tandem: \$.002902
(b) Local Traffic delivered to terminating Service Electric End Office/node: \$.001864

C. Miscellaneous Notes

1. In the event a Party desires to deliver Local Traffic to a LSWC (i) that is not located within 25 miles of the Tandem Office that it subtends, or (ii) where the Tandem Office that it subtends is not located within 25 miles of the Tandem Office that is subtended by the terminating End Office, or (iii) that is not located within 25 miles of the Tandem Office that is subtended by the terminating End Office, then the Party shall (x) in addition to paying the LSWC/Access Tandem termination rate described above, purchase the necessary facilities from the terminating Party to transport such Traffic to a qualifying LSWC or Access Tandem that is not subject to any of conditions (i), (ii), or (iii) above, (y) purchase such other service(s) as the terminating Party may offer under applicable tariff to remedy such condition(s), or (z) enter into a new compensation arrangement as the Parties may agree. Notwithstanding the foregoing, nothing in this Agreement shall obligate BA to provide switching services at a LSWC when it functions as such.

2. The Service Electric termination rate under the single-tiered interconnection structure set forth above is intended to be a Local Traffic termination rate for Interconnection to the Service Electric-IP within each LATA that is reciprocal and equal to the actual rates that will be charged by BA to Service Electric under the two-tiered Local Traffic termination rate structure described above that will apply after the first anniversary of the Effective Date. The single Service Electric termination rate is also intended to provide financial incentives to Service Electric to deliver traffic directly to BA's terminating End Offices once Service Electric's traffic volumes reach an appropriate threshold.

APPENDIX 1

**INTERCONNECTION AGREEMENT UNDER SECTIONS 251 AND 252 OF THE
TELECOMMUNICATIONS ACT OF 1996**

Dated as of July 8, 1998

by and between

BELL ATLANTIC - PENNSYLVANIA, INC.

AND

MCImetro ACCESS TRANSMISSION SERVICES, INC.

TABLE OF CONTENTS

| | |
|---|--------|
| A. GENERAL TERMS AND CONDITIONS | A - 2 |
| Section 1 - Scope of This Agreement | A - 2 |
| 1.4 Construction | A - 3 |
| Section 2 - Regulatory Approvals | A - 4 |
| Section 3 - Term of Agreement | A - 5 |
| Section 4 - Charges and Payment | A - 6 |
| Section 5 - Assignment | A - 6 |
| Section 6 - Compliance with Laws | A - 6 |
| Section 7 - Governing Law | A - 7 |
| Section 8 - Relationship of Parties | A - 7 |
| Section 9 - No Third Party Beneficiaries | A - 8 |
| Section 10 - Intellectual Property Rights | A - 8 |
| Section 11 - Indemnification | A - 9 |
| Section 12 - Limitation of Liability | A - 10 |
| Section 13 - Warranties | A - 11 |
| Section 14 - Notices | A - 12 |
| Section 15 - Technical References | A - 13 |
| Section 16 - Remedies | A - 14 |
| Section 17 - Waivers | A - 14 |
| Section 18 - Survival | A - 15 |
| Section 19 - Force Majeure | A - 15 |

| | |
|--|--------|
| Section 20 - Publicity | A - 20 |
| Section 21 - Default and Termination | A - 16 |
| 21.3 Billing Disputes | A - 16 |
| Section 22 - Confidentiality | A - 18 |
| Section 23 - Audits and Examinations | A - 21 |
| Section 24 - Dispute Resolution Procedures | A - 22 |
| Section 25 - Bona Fide Request Process for Further Unbundling | A - 23 |
| Section 26 - Branding | A - 25 |
| Section 27 - Taxes | A - 26 |
| Section 28 - Responsibility for Environmental Contamination | A - 29 |
| Section 29 - Facilities | A - 29 |
| Section 30 - Option to Obtain Services Under Other Agreements | A - 30 |
| Section 31 - Other Services | A - 30 |
| Section 32 - Provision and Use of Services | A - 31 |
| Section 33 - Selection of IntraLATA Telecomm. Service Provider | A - 32 |
| Section 34 - Service Standards | A - 32 |
| Section 35 - Subcontracting | A - 33 |
| Section 36 - Amendments and Modifications | A - 33 |
| Section 37 - Severability | A - 33 |
| Section 38 - Headings Not Controlling | A - 34 |
| Section 39 - Entire Agreement | A - 34 |
| Section 40 - Counterparts | A - 34 |
| Section 41 - Successors and Assigns | A - 34 |

July 8, 1997

PART A

Section 42 - Good Faith Performance

A - 34

Section 43 - Joint Work Product

A - 34

**MCImetro/Bell Atlantic
INTERCONNECTION AGREEMENT 1997**

This MCImetro/Bell Atlantic Interconnection Agreement (the "Agreement"), effective on the date the Pennsylvania Public Utility Commission approves this Agreement, is entered into by and between MCImetro Access Transmission Services, Inc. ("MCIm"), a Delaware corporation, and Bell Atlantic-Pennsylvania, Inc. ("Bell Atlantic" or "BA"), a Pennsylvania corporation, to establish the rates, terms and conditions for the purchase and provision of Local Interconnection, Local Resale, unbundled Network Elements and other services, all as set forth in this Agreement (individually referred to as the "service" or collectively as the "services") for the purpose of the purchasing Party's provision of Telephone Exchange Service, Exchange Access Service, and/or Telecommunications Services.

WHEREAS, on February 8, 1996, the Communications Act of 1934, 47 U.S.C. § 151, *et seq.*, (the "Act") was amended by the Telecommunications Act of 1996; and

WHEREAS, the Act places certain duties and obligations upon, and grants certain rights to, Telecommunications Carriers and Local Exchange Carriers; and

WHEREAS, the Parties are Telecommunications Carriers and Local Exchange Carriers; and

WHEREAS, the Act places certain duties and obligations upon, and grants certain rights to, Incumbent Local Exchange Carriers, and Bell Atlantic is an Incumbent Local Exchange Carrier; and

WHEREAS, the Parties wish to interconnect their local exchange networks for the provision of Telephone Exchange Service, for the transmission and termination of local calls, so that subscribers of each can receive local calls that originate on the other's network and place local calls that terminate on the other's network, and for use in the provision of Exchange Access Service ("Local Interconnection"); and

WHEREAS, MCIm wishes to purchase Telecommunications Services for resale to others ("Local Resale" or "Services for Resale"), and Bell Atlantic is willing to provide such service; and

WHEREAS, MCIm wishes to purchase on an unbundled basis Network Elements, and to use such services for the provision of Telecommunications Services to others, and Bell Atlantic is willing to provide such services on the terms set forth herein; and

WHEREAS, the Parties intend the rates, terms and conditions of this Agreement, and their performance of obligations thereunder, to comply with the Act, the Rules and Regulations of the Federal Communications Commission ("FCC"), and the orders, rules and regulations of the Pennsylvania Public Utility Commission (the "Commission");

NOW, THEREFORE, in consideration of the premises and the mutual covenants of this Agreement, and intending to be legally bound by this Agreement, the Parties hereby covenant and agree as follows:

PART A -- GENERAL TERMS AND CONDITIONS

Section 1. Scope of this Agreement

1.1 This Agreement, consisting of Parts A, B and C, specifies the rights and obligations of each Party with respect to the purchase and sale of Local Interconnection, Local Resale and Network Elements. This PART A sets forth the general terms and conditions governing this Agreement. Capitalized terms used in this Agreement shall have the meanings defined in PART B -- DEFINITIONS, or as otherwise elsewhere defined throughout this Agreement. PART C sets forth, among other things, descriptions of the services, pricing, technical and business requirements, and physical and network security requirements.

LIST OF ATTACHMENTS COMPRISING PART C:

- I. Price Schedule
- II. Local Resale
- III. Network Elements
- IV. Interconnection
- V. Collocation
- VI. Rights of Way
- VII. Number Portability
- VIII. Business Process Requirements
- IX. Security Requirements
- X. Performance Reporting

1.2 Bell Atlantic shall provide the services in any Technically Feasible Combination requested by MCI, pursuant to the terms of this Agreement and in accordance with the requirements of Applicable Law, or where appropriate, the Bona Fide Request ("BFR") process set forth in Section 25 (BFR Process for Further Unbundling) of Part A, except that Local Resale shall be provided pursuant to Attachment II. Neither Party shall discontinue or refuse to provide any service provided or required hereunder, except in accordance with the terms hereof, without the other Party's written agreement. Bell Atlantic shall not reconfigure, reengineer or otherwise redeploy its network in a manner which would impair MCI's ability to offer Telecommunications Services in the manner contemplated by this Agreement, the Act or the FCC's Rules and Regulations without providing notice of Network Changes in accordance with the Act and FCC Rules and Regulations.

1.3 The Parties acknowledge that some of the services, facilities and arrangements provided pursuant to this Agreement are or will be available under and subject to the

terms of the federal or state Tariffs of the Party providing them. To the extent that a Tariff of a Party applies to any service, facility or arrangement provided pursuant to this Agreement, the following shall apply:

1.3.1 The rates and charges set forth in Attachment I shall remain fixed for the term of this Agreement or until superseded by such rates (whether interim or permanent) as may be applied by the Commission, notwithstanding that either of such rates may be different from those set forth in any effective, pending or future Tariff of the providing Party, (including any changes or modifications to any such Tariff--or any new Tariff--filed after the Effective Date of this Agreement); provided, however, this Section 1.3.1 shall remain subject to Section 1.3.3.

1.3.2 This Agreement and any applicable Tariffs of either Party shall be construed whenever possible to avoid any conflict between them. The fact that a condition, term, right or obligation appears in the Agreement and not in a Tariff, or in a Tariff but not in the Agreement, shall not be interpreted as, or deemed grounds for finding, a conflict for the purposes of this Section 1.3.

1.3.3 Any change or modification to any Tariff (including any Tariff filed after the Effective Date hereof) filed by either Party that materially and adversely impacts the provision or receipt of services hereunder or which materially and adversely alters the terms hereof shall only be effective against the other Party to the extent permitted by: (i) that Party's written consent; or (ii) an affirmative order of the Commission. Each Party shall file any required Tariff revisions, modifications or amendments in order to comply with Applicable Law and to continue performance of this Agreement in a lawful manner.

1.4 Construction

1.4.1 For purposes of this Agreement, certain terms have been defined in Part B or elsewhere in this Agreement. These terms will have the meanings stated in this Agreement, which may differ from, or be in addition to, the normal definition of the defined word. A defined word intended to convey the meaning stated in this Agreement is capitalized when used. Other terms that are capitalized, and not defined in this Agreement, shall have the meaning stated in the Act.

1.4.2 Unless the context clearly indicates otherwise, any defined term which is defined or used in the singular shall include the plural, and any defined term which is defined or used in the plural shall include the singular.

1.4.3 The words "shall" and "will" are used interchangeably throughout this Agreement and the use of either indicates a mandatory requirement. The use of one or the other shall not mean a different degree of right or obligation for either Party.

1.4.4 Conflicts among terms in Parts A and B of this Agreement, the Attachments and the Exhibits thereto, and the Tariffs shall be resolved in accordance with the following order of precedence, where the document identified in Subsection "(i)" shall have the highest precedence: (i) Parts A and B of this Agreement; (ii) the Attachments and the Exhibits thereto; and (iii) the Tariffs. The fact that a matter is addressed in one of these documents, but not in another, shall not constitute a conflict for purposes of this Section 1.4.4.

Section 2. Regulatory Approvals

2.1 The Parties shall promptly submit this Agreement, and any amendment or modification hereof, to the Commission for approval in accordance with Section 252 of the Act. Following such submission, the Parties shall submit the Agreement to any other applicable governmental entity for any requisite approvals. In the event any governmental authority or agency rejects any provision hereof, the Parties shall negotiate promptly and in good faith such revisions as may reasonably be required to achieve approval.

2.2 In the event the FCC or the Commission promulgates rules or regulations, or issues orders, or a court of competent jurisdiction issues orders, which make unlawful any provision of this Agreement, or which materially reduce or alter the services required by statute or regulations and embodied in this Agreement, then the Parties shall negotiate promptly and in good faith in order to amend the Agreement to substitute contract provisions which conform to such rules, regulations or orders. In the event the Parties cannot agree on an amendment within thirty (30) days after the date any such rules, regulations or orders become effective, then the Parties shall resolve their dispute under the applicable procedures set forth in Section 24 (Dispute Resolution Procedures) hereof.

2.3 The Parties intend that any services requested by either Party relating to the subject matter of this Agreement that are not offered hereunder will be incorporated into this Agreement by amendment upon agreement by the Parties.

2.4 In the event that any legally effective legislative, regulatory, judicial or other legal action materially affects any material terms of this Agreement, or the ability of MCI or Bell Atlantic to perform any material terms of this Agreement, MCI or Bell Atlantic may, on thirty (30) days written notice (delivered not later than thirty (30) days following the date on which such action has become legally binding or has otherwise become legally effective) require that such terms be renegotiated, and the Parties shall renegotiate in good faith such mutually acceptable new terms as may be required.

2.5 When this Agreement is filed with the Commission for approval, the Parties will request that the Commission: (a) approve the Agreement, and (b) refrain from taking any action to change, suspend or otherwise delay implementation of the Agreement.

2.6 Each Party shall be responsible for obtaining and keeping in effect all FCC, Commission, franchise authority and other governmental approvals, that may be required in connection with the performance of its respective obligations under this Agreement.

Section 3. Term of Agreement

3.1 This Agreement shall become effective as of the Effective Date stated above and, except as otherwise provided in this Agreement, shall remain in effect until August 31, 2000, and thereafter until terminated as provided in this Agreement. At least one hundred eighty (180) days before the term expires, either Party shall file with the Commission any request for an extension of that term, and shall on the same day provide notice to the other Party. At least one hundred fifty (150) days before the term expires, the other Party shall respond to the requested extension. If for any reason a new agreement has not been reached by the end of the three-year term, the existing interconnection agreement shall continue, month-to-month, under the same terms and conditions, subject to a true-up, until resolved by the Commission.

3.2 This Agreement shall be effective between the Parties as of the Effective Date, notwithstanding the pendency of proceedings challenging the Commission's approval of the Agreement.

3.3 Each Party recognizes that the services being provided under this Agreement at the time of its termination may need to be continued without interruption thereafter, and that upon such termination, either Party may itself provide or retain another vendor to provide comparable services. Each Party agrees to cooperate in an orderly and efficient transition to the other Party or another vendor such that the level and quality of the services are not degraded, and to exercise reasonable efforts to effect an orderly and efficient transition.

3.4 Unless a service is required to be offered by a Party under Applicable Law, either Party may terminate any service provided under this Agreement upon thirty (30) days prior written notice to the other Party unless a different notice period or different conditions are specified in this Agreement (including, but not limited to, in an applicable Tariff or Applicable Law) for termination of such service, in which event such specified period and/or conditions shall apply. Upon termination of its purchase of a service by the purchasing Party, the purchasing Party shall pay any applicable termination charges specified in this Agreement. Upon termination of a Local Resale service by Bell Atlantic, MCI shall be entitled to continue providing the terminated service to MCI's subscribers on a grandfathered basis to the same extent, and subject to the same terms and conditions, as would apply to such subscribers if they had been subscribers of Bell Atlantic for the terminated service at the time the service is terminated, and Bell Atlantic shall continue to provide such services to MCI on the same basis.

3.5 Following the expiration of this Agreement, this Agreement shall remain in effect as to any Expiring Service for the remainder of any contract period applicable to such Expiring Service at the time of the expiration of this Agreement. If an Expiring Service

is terminated prior to the expiration of the contract period applicable to such Expiring Service, MCI shall pay any termination charge provided for in this Agreement, in an applicable Tariff, or in the contract applicable to the Expiring Service. Following expiration of the applicable contract period for an Expiring Service, the Expiring Service, until terminated, shall be subject to: (i) any effective agreement superseding this Agreement; or (ii) to the extent such Expiring Service is not covered by such superseding agreement, applicable Tariffs. For the purposes of this Section 3.5, "Expiring Service" means: (a) any Local Resale service that, upon expiration of the term of this Agreement, is being provided under this Agreement and is subject to a remaining contract period greater than one (1) month; or (b) any Local Resale service: (i) for which an order has been submitted and accepted pursuant to this Agreement prior to the expiration of this Agreement but such service is not being provided at the expiration of this Agreement; and (ii) that is subject to an initial contract period which is greater than one (1) month.

Section 4. Charges and Payment

4.1 In consideration of the services provided under this Agreement, the purchasing Party shall pay the charges set forth in Attachment I. The billing and payment procedures for charges incurred by a purchasing Party hereunder are set forth in Attachment VIII.

Section 5. Assignment

5.1 Any assignment or delegation by either Party to any non-affiliated entity of any right, obligation or duty, or of any other interest hereunder, in whole or in part, without the prior written consent of the other Party shall be void (except the assignment of a right to moneys due or to become due). A Party assigning or delegating this Agreement or any right, obligation, duty or other interest hereunder to an Affiliate shall provide written notice to the other Party. All obligations and duties of any Party under this Agreement shall be binding on all successors in interest and assigns of such Party. No assignment or delegation hereof shall relieve the assignor of its obligations under this Agreement.

5.2 If any obligation of either Party is performed by a subcontractor or Affiliate, such Party shall remain fully responsible for the performance of this Agreement in accordance with its terms.

Section 6. Compliance with Laws

6.1 Each Party shall perform terms, conditions and operations under this Agreement in a manner that complies with all Applicable Law, including all regulations and judicial or regulatory decisions of all duly constituted governmental authorities of competent jurisdiction. Each Party shall be responsible for obtaining and keeping in effect all FCC, state regulatory commission, franchise authority and other regulatory approvals that may be required in connection with the performance of its obligations under this Agreement. Each Party shall reasonably cooperate with the other in obtaining and maintaining any approvals required by this Section. In the event the Act or FCC Rules and Regulations

applicable to this Agreement are held invalid, this Agreement shall survive, and the Parties shall promptly renegotiate any provisions of this Agreement which, in the absence of such invalidated Act, Rule or Regulation, are insufficiently clear to be effectuated.

6.2 Except as otherwise specified in this Agreement, each Party shall be responsible for: (i) all costs and expenses it incurs in complying with its obligations under this Agreement; and (ii) the development, modification, technical installation and maintenance of any systems or other infrastructure which it requires to comply with and to continue complying with its responsibilities and obligations under this Agreement.

Section 7. Governing Law

7.1 The validity of this Agreement, the construction and enforcement of its terms, and the interpretation of the rights and duties of the Parties, shall be governed by the Act and the laws of the Commonwealth of Pennsylvania, without regard to its conflicts of laws rules.

Section 8. Relationship of Parties

8.1 Each Party is an independent contractor, and has and hereby retains the right to exercise full control of and supervision over its own performance of its obligations under this Agreement.

8.2 Each Party retains full control over the employment, direction, compensation and discharge of all of its employees, agents and contractors assisting in the performance of its obligations under this Agreement. Each Party will be solely responsible for all matters relating to payment of its employees, agents and contractors, and payment of Social Security and other taxes in association with such employees, agents and contractors, and withholding and remittance of taxes from such employees, agents and contractors.

8.3 Nothing contained within this Agreement shall:

8.3.1 Make either Party the agent, servant or employee, of the other Party;

8.3.2 Grant either Party the authority to enter into a contract on behalf of, or otherwise legally bind, the other Party in any way;

8.3.3 Create a partnership, joint venture, or other similar relationship between the Parties; or

8.3.4 Grant to either Party a franchise, distributorship, or similar interest.

8.4 The relationship of the Parties under this Agreement is a non-exclusive relationship. Each Party shall have the right:

8.4.1 To provide services to be provided by it under this Agreement to persons other than the other Party; and

8.4.2 To purchase services which can be purchased by it under this Agreement from persons other than the other Party.

Section 9. No Third Party Beneficiaries

9.1 Except as may be specifically set forth in this Agreement, this Agreement does not provide and shall not be construed to provide any third parties (including, but not limited to, subscribers or subcontractors of a Party) with any right, remedy, claim, reimbursement, cause of action, or other privilege. The provisions of this Agreement are for the benefit of the Parties hereto and not for any other person, provided, however, that this shall not be construed to prevent either Party from providing its Telecommunications Services to any entities.

Section 10. Intellectual Property Rights

10.1 Any intellectual property which originates from or is developed by a Party shall remain in the exclusive ownership of that Party. Except for a limited license to use a Party's patents or copyrights to the extent necessary for the Parties to use any facilities or equipment (including software) or to receive any service solely as provided under this Agreement, no license in patent, copyright, trademark or trade secret, or other proprietary or intellectual property right now or hereafter owned, controlled or licensable by a Party, is granted to the other Party or shall be implied or arise by estoppel.

10.2 Bell Atlantic shall indemnify MCIIm with respect to MCIIm's use, pursuant to the terms of this Agreement, of intellectual property associated with any new Bell Atlantic network equipment or software acquisitions. Bell Atlantic warrants that it will not enter into any licensing agreements with respect to new Bell Atlantic network equipment or software acquisitions that contain provisions that would disqualify MCIIm from using or interconnecting with such network equipment or software pursuant to the terms of this agreement. Bell Atlantic also warrants that it has not and will not intentionally modify any existing licensing agreements for existing network equipment or software in order to disqualify MCIIm from using or interconnecting with such network equipment or software pursuant to the terms of this agreement. To the extent that the providers of equipment or software in Bell Atlantic's network provide Bell Atlantic with indemnities covering intellectual property liabilities and those indemnities allow a flow through of protection to third parties, Bell Atlantic shall flow those indemnity protections through to MCIIm. Bell Atlantic will inform MCIIm of any pending or threatened intellectual property claims relating to Bell Atlantic's network of which Bell Atlantic is aware and will update that notification periodically as needed, so that MCIIm receives maximum notice of any intellectual property risks it might want to address. Notwithstanding any part of this Section 10, MCIIm retains the right to pursue legal remedies against Bell Atlantic if Bell Atlantic is at fault in causing intellectual property liability to MCIIm.

10.2.1 For purposes of Section 10.2, Bell Atlantic's obligation to indemnify shall include the obligation to indemnify and hold MCIIm harmless from and against any loss, cost, expense or liability arising out of a claim that MCIIm's use, pursuant to the terms of this Agreement, of such new Bell Atlantic network equipment or software infringes the intellectual property rights of a third party. Moreover, should any such network equipment or software or any portion thereof provided by Bell Atlantic hereunder become, or, in Bell Atlantic's reasonable opinion, be likely to become, the subject of a claim of infringement, or should MCIIm's use thereof be finally enjoined, Bell Atlantic shall, at its immediate expense and at its choice:

10.2.1.1 Procure for MCIIm the right to continue using such material; or

10.2.1.2 Replace or modify such material to make it non-infringing provided such replacement or modification is functionally equivalent.

10.3 Unless otherwise mutually agreed upon, neither Party shall publish or use the other Party's logo, trademark, or service mark in any product, service, advertisement, promotion, or any other publicity matter, except that nothing herein shall prohibit lawful comparative advertising or comparative marketing.

Section 11. Indemnification

11.1 Each Party agrees to release, indemnify, defend and hold harmless the other Party from and against all losses, claims, demands, damages, expenses, suits or other actions, or any liability whatsoever, including, but not limited to, costs and attorneys' fees (collectively, a "Loss") incurred by the indemnified Party to the extent that such Loss is: (a) suffered, made, instituted, or asserted by any other person, relating to personal injury to or death of any person, or for loss, damage to, or destruction of real and/or personal property, whether or not owned by others, incurred during the term of this Agreement and to the extent legally caused by the acts or omissions of the indemnifying Party, regardless of the form of action; or (b) suffered, made, instituted, or asserted by the indemnifying Party's own customer(s) against the indemnified Party arising out of the indemnified Party's provision of services to the indemnifying Party under this Agreement, except to the extent the Loss arises from a breach of this Agreement by the indemnified Party. Notwithstanding the foregoing indemnification, nothing in this Section 11 shall affect or limit any claims, remedies, or other actions the indemnifying Party may have against the indemnified Party under this Agreement, any other contract, or any applicable Tariff(s), regulations or laws.

11.2 MCIIm shall indemnify, defend and hold harmless Bell Atlantic, Bell Atlantic's Affiliates, and the directors, officers and employees of Bell Atlantic and Bell Atlantic's Affiliates, from and against any claim, demand, suit, action, judgment, liability, damage or loss (including reasonable costs, expenses and attorneys' fees on account thereof), that arises out of or results from: (i) MCIIm's negligent use or occupancy of a Bell Atlantic

NID; (ii) wiring, facilities, equipment or other apparatus, negligently installed by MCI in or on a Bell Atlantic NID, or negligently connected by MCI to a Bell Atlantic NID; or (iii) the negligent acts or omissions of MCI, MCI's Affiliates, or the employees, agents or contractors of MCI or MCI's Affiliates, in connection with a Bell Atlantic NID. Where the NID is not used by Bell Atlantic or another Telecommunications Carrier (except MCI) to provide service to the premise, MCI shall have the burden, as between Bell Atlantic and MCI, to rebut the presumption that the claim, demand, suit, action, judgment, liability, damage or loss arises from wiring, facilities, equipment or other apparatus, negligently installed by MCI in or on a Bell Atlantic NID, or negligently connected by MCI to a Bell Atlantic NID. For the purposes of this Section 11.2, references to "negligence" or "negligently" shall be read to also encompass acts of gross negligence and/or intentional misconduct.

11.3 The indemnification provided herein shall be conditioned upon:

11.3.1 The indemnified Party shall promptly notify the indemnifying Party of any action taken against the indemnified Party relating to the indemnification, provided that failure to notify the indemnifying Party shall not relieve it of any liability it might otherwise have under this Section 11 to the extent it was not materially prejudiced by such failure of notification.

11.3.2 The indemnifying Party shall have sole authority to defend any such action, including the selection of legal counsel, and the indemnified Party may engage separate legal counsel only at its sole cost and expense. In the event the indemnifying Party does not accept the defense of any such action, the indemnified Party shall have the right to employ counsel for its own defense at the expense of the indemnifying Party.

11.3.3 In no event shall the indemnifying Party settle or consent to any judgment pertaining to any such action without the prior written consent of the indemnified Party, which consent shall not be unreasonably withheld.

11.3.4 In any action for which indemnity is sought, the indemnified Party shall assert any and all provisions in applicable Tariffs that limit liability to third parties as a bar to any recovery by the third party claimant in excess of applicable limitations of liability.

11.3.5 The indemnified Party shall offer the indemnifying Party all reasonable cooperation and assistance in the defense of any such action.

Section 12. Limitation of Liability

12.1 Neither Party shall be liable to the other for any indirect, incidental, special or consequential damages arising out of or related to this Agreement or the provision of service hereunder. Notwithstanding the foregoing limitation, a Party's liability shall not

be limited by the provisions of this Section 12 in the event of its willful or intentional misconduct, including gross negligence. Bell Atlantic shall be liable to MCI for lost revenues resulting from Bell Atlantic's breach of this Agreement only to the same extent that Bell Atlantic's Tariffs provide liability for Bell Atlantic end user subscribers' revenue losses. A Party's liability shall not be limited with respect to its indemnification obligations.

Section 13. Warranties

13.1 As more specifically set forth herein, each Party shall perform its obligations hereunder at Parity, as defined in Part B of this Agreement, which definition is intended to embody the performance provisions set forth in 47 U.S.C. § 251, and any implementing regulations thereunder, as those provisions may apply to the Party and obligation in question.

13.2 As more specifically set forth in Attachment II, Bell Atlantic shall provide Local Resale at Parity.

13.3 As more specifically set forth in Attachment III, Bell Atlantic shall provide Network Elements at Parity.

13.4 As more specifically set forth in Attachment IV, Bell Atlantic shall provide Interconnection at Parity and on a Non-Discriminatory Basis. MCI shall provide Interconnection on a Non-Discriminatory Basis.

13.5 As more specifically set forth in Attachment V, Bell Atlantic shall provide Collocation in accordance with the legally effective rules, regulations and orders of the FCC and the Commission.

13.6 As more specifically set forth in Attachment VI, Bell Atlantic shall provide Non-Discriminatory access to poles, ducts, conduits, and ROW owned or controlled by Bell Atlantic, in accordance with the requirements of section 224 of the Act and legally effective rules, regulations and orders of the FCC and the Commission.

13.7 As more specifically set forth in Attachment VII, Bell Atlantic and MCI shall provide Interim Number Portability and Number Portability in accordance with the legally effective rules, regulations and orders of the FCC and the Commission.

13.8 As more specifically set forth in Attachment VIII, Bell Atlantic and MCI shall meet Business Process Requirements.

13.9 As more specifically set forth in Attachment VIII, Bell Atlantic shall provide Non-Discriminatory access to telephone numbers for as long as Bell Atlantic remains the code administrator for the North American Numbering Plan.

13.9

13.10 As more specifically set forth in Attachment VIII, Bell Atlantic and MCI shall provide dialing parity in accordance with the legally effective rules, regulations and orders of the FCC and the Commission.

13.11 As more specifically set forth in Attachment IX, Bell Atlantic and MCI shall meet security requirements, to the extent applicable to the security requirement in question.

13.12 As more specifically set forth in Attachment X, Bell Atlantic shall provide performance reporting.

EXCEPT AS SET FORTH IN THIS AGREEMENT, NEITHER PARTY MAKES ANY WARRANTIES WITH RESPECT TO ITS SERVICES, WHETHER EXPRESS OR IMPLIED, WRITTEN OR ORAL, IN FACT OR IN LAW. THE WARRANTIES SET FORTH IN THIS AGREEMENT ARE A PARTY'S EXCLUSIVE WARRANTIES WITH RESPECT TO ITS SERVICES AND ARE IN LIEU OF ALL OTHER WARRANTIES, EXPRESS OR IMPLIED, WRITTEN OR ORAL, IN FACT OR IN LAW. EACH PARTY DISCLAIMS ANY AND ALL OTHER WARRANTIES WITH RESPECT TO ITS SERVICES, INCLUDING, BUT NOT LIMITED TO, WARRANTIES OF MERCHANTABILITY AND FITNESS FOR A PARTICULAR PURPOSE AND WARRANTIES AGAINST INFRINGEMENT.

Section 14. Notices

14.1 Except as otherwise provided herein, or where context or services dictate that immediate notice be given, all notices or other communication hereunder shall be deemed to have been duly given when made in writing and delivered in person or deposited in the United States mail, certified mail, postage prepaid, return receipt requested and addressed as follows:

To MCI: MCImetro Access Transmission Services, Inc.
Attention: Vice President
1650 Tysons Boulevard
McLean, VA 22102

Copy to: General Counsel
MCI Communications Corporation
1801 Pennsylvania Ave., N.W.
Washington, DC 20006

To Bell Atlantic: Bell Atlantic Network Services, Inc.
Attention: Director, Interconnection Initiatives
1320 North Courthouse Road, 9th Floor
Arlington, VA 22201

Copy to: Legal Department
Bell Atlantic Network Services, Inc.
Attention: Counsel, Carrier Services
1320 North Courthouse Road, 8th Floor
Arlington, VA 22201

If personal delivery is selected to give notice, a receipt of such delivery shall be obtained. The address to which notices or communications may be given to either Party may be changed by written notice given by such Party to the other pursuant to this Section 14.

Section 15. Technical References

15.1 The Parties agree that the Bell Atlantic technical references set forth in Appendix I to this Part A (Technical Reference Schedule) provide the current technical specifications for the services offered by Bell Atlantic under this Agreement. Bell Atlantic reserves the right with reasonable notification to revise its technical references for any reason including, but not limited to, laws or regulations, conformity with updates and changes in standards promulgated by various agencies, utilization of advances in the state of technical arts, or the reflection of changes in the design of any facilities, equipment, techniques, or procedures described or referred to in the technical references. Notification of changes that are made to the underlying Bell Atlantic services will be made in conformance with the requirements of Section 25 (Section 5), Notice of Changes, of the Act, and the FCC's Rules and Regulations. The Parties acknowledge that the general technical references set forth below contain certain generally-accepted industry guidelines for particular interface and performance parameters for telecommunications equipment used by LECs in the United States. Such accepted technical references may be used by LECs to specify suitable equipment and facilities components for use in their respective networks, to assure interoperability between components that collectively comprise such networks, and to specify the interface characteristics and typical end-to-end performance of certain services.

15.2 The Parties acknowledge that they and their vendors and suppliers derive guidance from such technical references, and make reasonable efforts to conform to them. Requests for specific performance, functionality, or capabilities not applied in a Party's network should be handled using the BFR process set forth in Section 25 (BFR Process for Further Unbundling) of this Part A.

15.3 If one or more of the technical requirements set forth in Appendix I are in conflict, the Parties shall reasonably agree on which requirement shall apply.

15.4 The Parties agree that they each intend, to the extent technically feasible and commercially reasonable, to conform generally to industry standards applicable to the Parties set by the OBF, within a reasonable time after publication of final standards. With respect to OBF and other industry standards, the Parties agree that they will negotiate in good faith the applicability, technical feasibility and commercial

reasonableness for implementation of such standards for services and arrangements under the Agreement.

Section 16. Remedies

16.1 The obligations of the Parties and the services offered under this Agreement may be unique. Accordingly, in addition to any other available rights or remedies, either Party may sue in equity for specific performance.

16.2 In the event either Party fails to switch a subscriber to the other Party's service as requested through a service request from the other Party, within any applicable intervals set forth in this Agreement or required by Applicable Law, or erroneously switches the other Party's subscriber away from that Party, then such act (including the continued provision of Telecommunications Services to such subscriber by the Party erroneously switching or failing to switch) shall be deemed an improper change in subscriber carrier selection commencing with the time at which such Party erroneously failed to switch such subscriber, or erroneously switched such subscriber. If such an improper change in subscriber carrier selection should occur, the rights and obligations of the Parties shall be determined in accordance with the regulations pertaining to such conduct on the part of Interexchange Carriers as set forth in the FCC's Rules and Regulations, Part 64, Subpart K, as these may be amended from time to time. For the purpose of this Section, Bell Atlantic shall be deemed an Interexchange Carrier.

16.3 At such time as the FCC or other competent regulatory body adopts regulations implementing 47 U.S.C. Section 258 or otherwise adopt regulations applicable to illegal or improper changes in local service, then such regulations shall supersede those applicable to Interexchange Carriers for the purposes of this Section 16.

16.4 Unless otherwise specifically provided hereunder, all rights of termination, cancellation or other remedies prescribed in this Agreement, or otherwise available, are cumulative and are not intended to be exclusive of other remedies to which the injured Party may be entitled at law or equity.

Section 17. Waivers

17.1 A failure or delay of either Party (including any course of dealing or course of performance) to enforce any of the provisions of this Agreement, or any right or remedy available under this Agreement or at law or in equity, or to require performance of any of the provisions of this Agreement, or to exercise any option provided under this Agreement, shall in no way be construed to be a waiver of such provisions, rights, remedies or options.

17.2 Waiver by either Party of any default by the other Party shall not be deemed a waiver of any other default.

Section 18. Survival

18.1 Any liabilities or obligations of a Party for acts or omissions occurring prior to the expiration, cancellation or termination of this Agreement, any obligation of a Party under any provision for indemnification or defense (including, but not limited to, any of Sections 10, 11, 12, 23, 24, 28 and 29), Section 3, "Termination", Section 22, "Confidential Information", any provision for limitation of liability, and any obligation of a Party under any other provisions of this Agreement which, by their terms, are contemplated to survive (or to be performed after) expiration, cancellation or termination of this Agreement, shall survive the expiration, cancellation or termination of the Agreement, but solely to the minimum extent necessary to effectuate such provisions or complete such performance.

Section 19. Force Majeure

19.1 Except as otherwise specifically provided in this Agreement (including, by way of illustration, circumstances where a Party is required to implement disaster recovery plans to avoid delays or failure in performance and the implementation of such plans was designed to avoid the delay or failure in performance), neither Party shall be liable for any delay or failure in performance of any part of this Agreement by it caused by acts or failures to act of the United States of America or any state, district, territory, political subdivision, or other governmental entity, acts of God or a public enemy, strikes, labor slowdowns, or other labor disputes, but only to the extent that such strikes, labor slowdowns, or other labor disputes also affect the performing Party, fires, explosions, floods, embargoes, earthquakes, volcanic actions, unusually severe weather conditions, wars, civil disturbances, or other causes beyond the reasonable control of the Party claiming excusable delay or other failure to perform ("Force Majeure Condition"). In the event of any such excused delay in the performance of a Party's obligation(s) under this Agreement, the due date for the performance of the original obligation(s) shall be extended by a term equal to the time lost by reason of the delay. In the event of such delay, the delaying Party shall perform its obligations at a performance level no less than that which it uses for its own operations. In the event of such performance delay or failure by Bell Atlantic, Bell Atlantic agrees to resume performance at Parity and in a Non-Discriminatory manner.

19.2 If any Force Majeure Condition occurs, the Party whose performance fails or is delayed because of such Force Majeure Condition shall give prompt notice to the other Party, and upon cessation of such Force Majeure Condition, shall give like notice and commence performance hereunder as promptly as reasonably practicable.

19.3 Notwithstanding Section 19.1, no delay or other failure by a Party to perform shall be excused pursuant to this Section by the delay or failure of a Party's subcontractors, materialmen, or suppliers to provide products or services to the Party, unless such delay or failure is itself the product of a Force Majeure Condition, and such products or services cannot be obtained by the Party from other persons on commercially reasonable terms.

Section 20. Publicity

20.1 Neither Party shall produce, publish, or distribute any press release or other publicity referring to the other Party in connection with this Agreement, without the prior written approval of the other Party, which approval shall not be unreasonably withheld.

Section 21. Default and Termination

21.1 If a Party ("Breaching Party") materially breaches a material provision of this Agreement (other than an obligation to make payment of any amount billed under this Agreement), and such breach continues for more than thirty (30) days after written notice thereof from the other Party ("Injured Party"), then, except as otherwise required by Applicable Law, the Injured Party shall have the right, upon notice to the Breaching Party, to terminate or suspend this Agreement and/or the provision of services.

21.2 If a purchasing Party fails to make a payment of any amount billed under this Agreement by the due date stated on the providing Party's bill and such failure continues for more than thirty (30) days after written notice thereof from the providing Party, then, except as provided in Section 21.3 or as otherwise required by Applicable Law, the providing Party shall have the right, upon notice to the purchasing Party, to terminate or suspend this Agreement and/or the provision of services.

21.3 Billing Disputes.

21.3.1 If a billing dispute arises concerning any charges billed pursuant to this Agreement by a providing Party to a purchasing Party, payments withheld or paid pending settlement of the dispute shall be subject to interest at the rate set forth in Bell Atlantic's interstate access tariff.

21.3.2 If the purchasing Party pays the bill in full by the payment due date and later initiates a billing dispute pursuant to Attachment VIII, Section 3.1.9, interest will apply as follows:

21.3.2.1 If the billing dispute is resolved in favor of the purchasing Party, the purchasing Party shall receive a credit from the providing Party. This credit will be an amount equal to the disputed amount, plus interest at the rate set forth in Bell Atlantic's interstate access tariff. This amount will apply from the date of the purchasing Party's payment through the date on which the purchasing Party receives payment of the disputed amount and accrued interest from the providing Party.

21.3.2.2 If the dispute is resolved in favor of the providing Party, neither a late payment charge nor an interest charge is applicable.

21.3.3 If the purchasing Party withholds payment on the bill (in full or in part) and initiates a billing dispute pursuant to Attachment VIII, Section 3.1.9, interest will apply as follows:

21.3.3.1 If the billing dispute is resolved in favor of the providing Party, the purchasing Party shall pay the providing Party a payment equal to the amount withheld by the purchasing Party, plus interest at the rate set forth in Bell Atlantic's interstate access tariff. This amount will apply from the payment due date through the date on which the providing Party receives payment of the disputed amount and accrued interest from the purchasing Party.

21.3.3.2 If the dispute is resolved in favor of the purchasing Party, neither a late payment charge nor an interest charge is applicable.

21.4 Notwithstanding the foregoing, if a Party's material breach is for any failure to perform in accordance with this Agreement which materially and adversely affects the provision of service of the non-breaching Party's subscribers, the non-breaching Party shall give notice of the breach and the breaching Party shall cure such breach within ten (10) days or within a period of time equivalent to the applicable interval required by this Agreement, whichever is shorter, and if the breaching Party does not, the non-breaching Party may, as its sole option, terminate this Agreement, or any parts hereof. The non-breaching Party shall be entitled to pursue all available legal and equitable remedies for such breach.

21.5 MCIIm may terminate this Agreement in whole or in part at any time for any reason upon sixty (60) days prior written notice, except with respect to termination of any particular service(s), in which case, upon thirty (30) days prior written notice. MCIIm's sole liability for such termination shall be payment of amounts due for services provided up to the date of termination, unless otherwise provided for in this Agreement or in a Tariff providing a termination liability or minimum term for a service.

21.6 In the event of any termination under this Section 21 and, if applicable, pursuant to Section 3.3, Bell Atlantic agrees to provide for an uninterrupted transition of the services Bell Atlantic is providing to MCIIm at the time of termination to MCIIm or another vendor designated by MCIIm, and MCIIm agrees to provide for an uninterrupted transition of services MCIIm is providing to Bell Atlantic at the time of termination to Bell Atlantic or another vendor designated by Bell Atlantic.

21.7 Notwithstanding any termination hereof, the Parties shall continue to comply with their obligations under the Act to provide interconnection in accordance with Applicable Law.

Section 22. Confidentiality

22.1 For the purposes of this Section 22, "Confidential Information" means the following information disclosed by one Party ("Discloser") to the other Party ("Recipient") in connection with this Agreement:

22.1.1 All information disclosed by either Party to the other pursuant to Attachments I-X of this Agreement arising from the performance of this Agreement, including, but not limited to, books, records, documents and other information disclosed in an audit performed pursuant to this Agreement; and

22.1.2 Such other information as is identified as Confidential Information in accordance with Section 22.2.

22.2 All information which is to be treated as Confidential Information under Section 22.1.2 shall:

22.2.1 If in written, graphic, electromagnetic, or other tangible form, be marked as "Confidential Information"; and

22.2.2 If oral, (i) be identified by the Discloser at the time of disclosure to be "Confidential Information", and (ii) be set forth in a written summary which identifies the information as "Confidential Information" and is delivered by the Discloser to the Recipient within ten (10) days after the oral disclosure.

22.2.3 Each Party shall have the right to correct an inadvertent failure to identify such oral information as Confidential Information by giving written notification within thirty (30) days after the information is disclosed. The Recipient shall, from that time forward, treat such information as Confidential Information.

22.3 In addition to any requirements imposed by law, including, but not limited to, 47 U.S.C. § 222, for a period of three (3) years from the receipt of Confidential Information from the Discloser, except as otherwise specified in this Agreement, the Recipient agrees:

22.3.1 To use the Confidential Information only for the purpose of performing under this Agreement, including, to the extent applicable, the planning and operation of the Recipient's network; and

22.3.2 To use the same degree of care that it uses with similar confidential information of its own, to hold the Confidential Information in confidence and to disclose it to no one other than the directors, officers and employees of the Recipient and the Recipient's Affiliates, having a need to know the Confidential Information for the purpose of performing under this Agreement.

22.4 A Recipient may disclose the Discloser's Confidential Information to a third party agent or consultant, provided that prior to such disclosure the agent or consultant has executed a written agreement of non-disclosure and non-use comparable in scope to the terms of this Section 22.

22.5 The Recipient may make copies of Confidential Information only as reasonably necessary to perform its obligations and exercise its rights under this Agreement. All such copies shall bear the same copyright and proprietary rights notices as are contained on the original.

22.6 The Recipient shall return all Confidential Information defined in Section 22.1.2 in the format in which it was received from the Discloser, including any copies made by the Recipient, within thirty (30) days after a written request is delivered to the Recipient, and/or destroy all such Confidential Information, except for Confidential Information that the Recipient reasonably requires to perform its obligations under this Agreement. If the Recipient loses or makes an unauthorized disclosure of the Discloser's Confidential Information, it shall notify the Discloser immediately and use reasonable efforts to retrieve the lost or improperly disclosed information.

22.7 The requirements of this Section 22 shall not apply to Confidential Information:

22.7.1 Which was in the possession of the Recipient free of restriction prior to its receipt from the Discloser;

22.7.2 After it becomes publicly known or available through no breach of this Agreement by the Recipient, the Recipient's Affiliates, or the directors, officers, employees, agents, or contractors, of the Recipient or the Recipient's Affiliates;

22.7.3 After it is rightfully acquired by the Recipient free of restrictions on its disclosure;

22.7.4 Which is independently developed by personnel of the Recipient; or

22.7.5 To the extent the disclosure is required by law, or made to a court, or governmental agency for the purpose of enforcing its rights under this Agreement; provided the Discloser has been notified of an intended disclosure promptly after the Recipient becomes aware of a required disclosure or decides to make such a voluntary disclosure to enforce its rights, the Recipient undertakes reasonable, lawful measures to avoid disclosing the Confidential Information until the Discloser has had reasonable time to seek a protective order, and the Recipient complies with any protective order that covers the Confidential Information to be disclosed.

22.8 Each Party's obligations to safeguard Confidential Information disclosed prior to expiration, cancellation or termination of this Agreement shall survive such expiration, cancellation or termination.

22.9 Confidential Information shall remain the property of the Discloser, and the Discloser shall retain all of the Discloser's right, title and interest in any Confidential Information disclosed by the Discloser to the Recipient. Except as otherwise expressly provided elsewhere in this Agreement, no license is granted by this Agreement with respect to any Confidential Information (including, but not limited to, under any patent, trademark, or copyright), nor is any such license to be implied, solely by virtue of the disclosure of any Confidential Information.

22.10 Each Party agrees that the Discloser would be irreparably injured by a breach of this Section 22 by the Recipient, the Recipient's Affiliates, or the directors, officers, employees, agents or contractors of the Recipient or the Recipient's Affiliates, and that the Discloser shall be entitled to seek equitable relief, including injunctive relief and specific performance, in the event of any breach of the provisions of this Section 22. Such remedies shall not be deemed to be the exclusive remedies for a breach of this Section 22, but shall be in addition to any other remedies available at law or in equity.

22.11 The provisions of this Section 22 shall be in addition to and shall not limit, alter, define or contradict any provisions of Applicable Law, including, but not limited to, 47 U.S.C. § 222, and are not intended to constitute a waiver by a Party of any right with regard to protection of the confidentiality of information (whether or not defined as "Confidential Information" for purposes of this Agreement) of the Party or its customers provided by Applicable Law.

22.12 Without in any way limiting the foregoing provisions of Section 22, each Party shall comply with 47 U.S.C. § 222, any implementing rules, regulations, and orders thereunder, and other federal and state rules and regulations addressing Customer Proprietary Network Information ("CPNI") and Carrier Information. A Party shall not access (including, but not limited to, through electronic interfaces and gateways provided under this Agreement), use or disclose CPNI or other customer information unless the Party has obtained any customer authorization required by Applicable Law for such access, use and/or disclosure. By accessing, using or disclosing CPNI or other customer information, a Party represents and warrants that the Party has obtained any customer authorization required by Applicable Law for such access, use or disclosure. A Party accessing, using or disclosing CPNI or other customer information shall upon request by the other Party provide proof of any customer authorization for such access, use or disclosure, required by Applicable Law (including, copies of any written authorization). Without limiting the foregoing provisions of this Section 22, where required by 47 U.S.C. § 222, or other provision of Applicable Law, a Party shall obtain a signed letter of authorization from the applicable end user in order to obtain CPNI or other customer information from the other Party.

22.13 Each Party ("Auditing Party") shall have the right to audit the other Party ("Audited Party"), to ascertain whether the Audited Party is complying with the requirements of Applicable Law and this Agreement with regard to the Audited Party's access to, and use and disclosure of, CPNI and other customer information, which is made available by the Auditing Party to the Audited Party under this Agreement. Any audit conducted under this Section 22.13 shall be conducted in accordance with Section 23, "Audits and Inspections". Any information disclosed by the Audited Party to the Auditing Party or the Auditing Party's employees, Agents or contractors, in an audit conducted under this Section 22.13 shall be considered to be Confidential Information under this Section 22.

22.14 To the extent permitted by Applicable Law, each Party ("Auditing Party") shall have the right to monitor the access of the other Party ("Audited Party") to CPNI and other customer information which is made available by the Auditing Party to the Audited Party under this Agreement, to ascertain whether the Audited Party is complying with the requirements of Applicable Law and this Agreement with regard to the Audited Party's access to, and use and disclosure of, such CPNI and other customer information. To the extent permitted by Applicable Law, the foregoing right shall include, but not be limited to, the right to electronically monitor the Audited Party's access to and use of CPNI and other customer information which is made available by the Auditing Party to the Audited Party under this Agreement through electronic interfaces or gateways, to ascertain whether the Audited Party is complying with the requirements of Applicable Law and this Agreement with regard to the Audited Party's access to, and use and disclosure of, such CPNI and other customer information.

22.15 Nothing herein shall be construed as limiting the rights of either Party with respect to its own subscriber information under any Applicable Law, including without limitation Section 222 of the Act.

Section 23. Audits and Examinations

23.1 As applicable consistent with the provision of the relevant services or functions by a Party under this Agreement, each Party may audit the other Party's books, records and documents for the purpose of evaluating the accuracy of the other Party's bills and performance reports rendered under this Agreement. Such audits may be performed no more than a total of four (4) times in a calendar year nor more often than once every nine (9) months for a specific subject matter area; provided, that particular subject matter audits may be conducted more frequently (but no more frequently than once in each calendar quarter) if the immediately prior audit for such area found previously uncorrected net inaccuracies or errors in billing or performance reporting in favor of the audited Party having an aggregate value of at least five percent (5%) of the amounts payable by the auditing Party, or statistics reportable by the audited Party, relating to services provided by the audited Party during the period covered by the audit.

23.2 In addition to the audits described in Section 23.1, each Party may audit the other Party's books, records and documents for the purpose of evaluating compliance with CPNI where the audited Party has access to CPNI in the custody of the auditing Party pursuant to this Agreement. Such CPNI audits must be performed in a minimally disruptive fashion, and an audited Party may bring objections to the Commission, if the audits are unnecessarily intrusive and the Parties cannot resolve their disputes. Such CPNI audits may not be performed more frequently than annually; provided, however, that the frequency of CPNI audits may be increased to quarterly if violations of a Party's CPNI obligations exceeds five percent (5%) of the audit sample.

23.3 The auditing Party may employ other persons or firms for this purpose. Such audit shall take place at a time and place agreed on by the Parties; provided, that the auditing Party may require that the audit commence no later than sixty (60) days after the auditing Party has given notice of the audit to the other Party.

23.4 The audited Party shall promptly correct any error that is revealed in a billing audit, including back-billing of any underpayments and making a refund, in the form of a billing credit, of any over-payments. Such back-billing and refund shall appear on the audited Party's bill no later than the bill for the third full billing cycle after the Parties have agreed upon the accuracy of the audit results.

23.5 Each Party shall cooperate fully in any audits required hereunder, providing reasonable access to any and all employees, books, records and documents, reasonably necessary to assess the accuracy of the audited Party's bills or performance reports, or compliance with CPNI obligations, as appropriate.

23.6 Audits shall be performed at the auditing Party's expense, provided that there shall be no charge for reasonable access to the audited Party's employees, books, records and documents necessary to conduct the audits provided for hereunder.

23.7 Books, records, documents, and other information, disclosed by the audited Party to the auditing Party or the Auditing Party's employees, agents or contractors in an audit under this Section 23, shall be deemed to be Confidential Information under Section 22.

23.8 This Section 23 shall survive expiration or termination of this Agreement for a period of two (2) years after expiration or termination of this Agreement.

Section 24. Dispute Resolution Procedures

24.1 In the event the Commission retains continuing jurisdiction to implement and enforce the terms and conditions of this Agreement, the Parties agree that any dispute arising out of or relating to this Agreement that the Parties themselves cannot resolve, may be submitted to the Commission for resolution. The Parties agree to seek expedited resolution by the Commission, pursuant to applicable procedures established by the Commission. During the Commission proceeding, each Party shall continue to perform

its obligations under this Agreement; provided, however that neither Party shall be required to act in any unlawful fashion. This provision shall not preclude the Parties from seeking relief available in any other forum.

24.2 The Parties acknowledge that the terms of this Agreement were established pursuant to an order of the Commission. Any and all of the terms of this Agreement may be altered or abrogated by a successful challenge to the Agreement (or to the order approving the Agreement) as permitted by Applicable Law. By signing this Agreement, the Parties do not waive the right to pursue such a challenge.

Section 25. Bona Fide Request Process for Further Unbundling

25.1 The Parties recognize that, because MCI plans to maintain a technologically advanced network, it is likely to seek further unbundling of Network Elements or the introduction of new Network Elements. Accordingly, MCI may request such new unbundled Network Elements or arrangements from time to time by submitting a request in writing ("Bona Fide Request" or "BFR"). Bell Atlantic shall promptly consider and analyze MCI's submission of a Bona Fide Request that Bell Atlantic provide: (a) a method of Interconnection or access to a Network Element not otherwise provided under this Agreement at the time of such Bona Fide Request; (b) a method of Interconnection or access to a Network Element that is different in quality to that which Bell Atlantic provides to itself, its Affiliates, or its subscribers at the time of such request; (c) Collocation at a location other than a Bell Atlantic Central Office; and (d) such other arrangement, service, or Network Element for which a Bona Fide Request is required under this Agreement. Items (a) through (d) above may be referred to individually as a "BFR Item." The Bona Fide Request process set forth herein does not apply to those services requested pursuant to Report & Order and Notice of Proposed Rulemaking 91-141 (rel. October 19, 1992), Paragraph 259 and Footnote 603 or subsequent orders.

25.2 A Bona Fide Request shall be submitted in writing and shall contain information required to perform a preliminary analysis of the requested BFR Item. Such information will include a technical description of each BFR Item and reasonable estimates of the number or volume requested, the location(s) of each BFR Item, and the date(s) each BFR Item is desired. MCI shall submit each BFR via United States Postal Service or private courier, return receipt requested.

25.3 MCI may cancel a Bona Fide Request at any time, but shall pay Bell Atlantic's reasonable and demonstrable costs of processing and/or implementing the Bona Fide Request up to the date of cancellation; except MCI shall not be charged for preliminary analysis if costs do not exceed one hundred dollars (\$100). Bell Atlantic shall notify MCI if costs will exceed five thousand dollars (\$5,000). Bell Atlantic shall provide MCI with weekly status reports on the progress of its analysis and shall include the cost of such status reports in the costs of processing the BFR.

25.4 Within fifteen (15) business days after its receipt of a Bona Fide Request, Bell Atlantic shall provide to MCIIm a preliminary analysis of the BFR Item. The preliminary analysis shall respond in one of the following ways:

25.4.1 confirm that Bell Atlantic will offer the BFR Item and identify the date (no more than ninety (90) days after the date of the preliminary analysis) when Bell Atlantic will deliver a firm price proposal, including service description, pricing and an estimated schedule for availability ("Bona Fide Request Price Proposal");

25.4.2 provide a detailed explanation that such BFR Item is not technically feasible and/or that the BFR Item does not qualify as one that is required to be provided under the Act;

25.4.3 inform MCIIm that Bell Atlantic must do laboratory testing to determine whether the BFR Item is technically feasible;

25.4.4 inform MCIIm that Bell Atlantic must do field testing to determine whether the BFR Item is technically feasible;

25.4.5 inform MCIIm that it is necessary for the Parties to undertake a joint technical/operational-field test in order to determine both technical feasibility and operational cost impacts of the BFR Item; or

25.4.6 request face-to-face meetings between technical representatives of both Parties to further explain the BFR Item. No later than five (5) business days following such meetings, Bell Atlantic will provide a preliminary analysis in one of the ways identified in Sections 25.4.1 through 25.4.5. Both Parties shall make reasonable efforts to schedule such meetings as expeditiously as possible.

25.5 Within ten (10) business days after receiving Bell Atlantic's preliminary analysis from Section 25.4.3, 25.4.4, or 25.4.5, MCIIm shall:

25.5.1 in the case of Sections 25.4.3 or 25.4.4, (i) negotiate a mutually agreeable, reasonably expeditious schedule for Bell Atlantic's testing, (ii) a mutually agreeable date (no more than ninety (90) days after the testing has shown the BFR Item is technically feasible) when Bell Atlantic will deliver a Bona Fide Request Price Proposal, and (iii) a mutually agreeable arrangement for sharing the testing costs; or

25.5.2 in the case of Section 25.4.5, (i) negotiate a mutually agreeable, reasonably expeditious schedule for joint technical operational field testing, (ii) a mutually agreeable date (no more than 90 days after the testing has shown the BFR Item is technically feasible) when Bell Atlantic will deliver a Bona Fide Request Price Proposal, and a mutually agreeable arrangement for sharing the testing costs.

25.6 In handling a Bona Fide Request pursuant to Section 25.4, Bell Atlantic shall, to the extent possible, utilize information from previously developed Bona Fide Requests in order to shorten its response times. MCI may take advantage of previously canceled BFR work performed by Bell Atlantic on the same BFR Item or a substantially similar BFR Item, to the extent applicable.

25.7 Within ten (10) business days after receiving Bell Atlantic's preliminary analysis from Section 25.4.1, MCI shall:

25.7.1 accept Bell Atlantic's date to deliver a Bona Fide Request Price Proposal;

25.7.2 negotiate as expeditiously as possible a different date for Bell Atlantic to deliver a Bona Fide Request Price Proposal; or

25.7.3 cancel the Bona Fide Request.

25.8 Unless the Parties otherwise agree, a BFR Item shall be priced in accordance with Section 252(d)(1) of the Act and any applicable FCC or Commission rules, regulations, or orders. Consistent with Applicable Law, the price for each BFR Item shall include the reasonable and demonstrable costs incurred by Bell Atlantic in responding to the BFR, to the extent that Bell Atlantic has not previously been reimbursed for such costs.

25.9 Within ninety (90) days after its receipt of the Bona Fide Request Price Proposal, MCI must either place an order for such BFR Item pursuant to the Bona Fide Request Price Proposal or, if it believes such Bona Fide Request Price Proposal is inconsistent with the requirements of the Act, seek arbitration by the Commission, including the use of any available expedited procedures. If, within ninety (90) days after its receipt of the Bona Fide Request Price Proposal, MCI fails to confirm an order for such BFR Item or seek arbitration by the Commission, Bell Atlantic may treat the Bona Fide Request as canceled by MCI. If within ninety (90) days after issuance of a Commission order finding that a Bona Fide Request Price Proposal is consistent with the requirements of the Act, MCI fails to place an order for such BFR Item, Bell Atlantic may treat the Bona Fide Request as canceled by MCI.

25.10 If a Party to a Bona Fide Request believes that the other Party is not requesting, or negotiating, or processing the Bona Fide Request in good faith, or disputes a determination, or price or cost quote, or is failing to act in accordance with Section 251 of the Act, such Party may seek mediation or arbitration by the Commission, including the use of any available expedited procedures, after giving the other Party written notice at least ten (10) days in advance.

Section 26. Branding

26.1 In all cases in which a Party has control over handling of services provided to customers of the other Party using services procured under this Agreement, the Party so

handling such services shall brand them at the points of subscriber contact as set forth in Attachment VIII.

26.2 When Bell Atlantic technicians (including Bell Atlantic contractor technicians) have contact with a customer during a premise visit on behalf of MCIIm, the Bell Atlantic technicians shall identify themselves as Bell Atlantic employees (or Bell Atlantic contractor employees) performing services on behalf of MCIIm. When a Bell Atlantic technician leaves a status card during a premise visit on behalf of MCIIm, the card will be a standard card used for other local service providers' customers, will be in substantially the form set forth in Exhibit A of this Part A, and will include the name and telephone number of each local service provider that elects to be listed on the card and agrees to compensate Bell Atlantic for that provider's share of Bell Atlantic's cost of printing and distributing the card. The Bell Atlantic technicians shall not leave any promotional or marketing literature for or otherwise market Bell Atlantic Telecommunications Services to the MCIIm customer during a premise visit on behalf of MCIIm, but may provide a telephone number for Bell Atlantic's customer service or sales department, in response to customer query about Bell Atlantic services.

26.3 This Section 26 shall not confer on either Party any rights to the service marks, trademarks and trade names owned by or used in connection with services by the other Party or its Affiliates, except as expressly permitted by this Section 26.

Section 27. Taxes

27.1 With respect to any purchase of services under this Agreement, if any Federal, state or local government tax, fee, duty, surcharge (including, but not limited to, any 911, telecommunications relay service, or universal service fund surcharge), or other tax-like charge (a "Tax") is required or permitted by Applicable Law to be collected from a Purchasing Party by the Providing Party, then: (i) the Providing Party shall bill the Purchasing Party for such Tax; (ii) the Purchasing Party shall timely remit such Tax to the Providing Party; and (iii) the Providing Party shall remit such collected Tax to the applicable taxing authority.

27.2 With respect to any purchase of services under this Agreement, if any Tax is imposed by Applicable Law on the receipts of the Providing Party, which Applicable Law permits the Providing Party to exclude certain receipts received from sales of services for resale by the Purchasing Party, such exclusion being based solely on the fact that the Purchasing Party is also subject to a tax based upon receipts ("Receipts Tax"), then the Purchasing Party (i) shall provide the Providing Party with notice in writing in accordance with Section 27.7 of its intent to pay the Receipts Tax, and (ii) shall timely pay the Receipts Tax to the applicable taxing authority.

27.3 With respect to any purchase of services under this Agreement, that are resold by the Purchasing Party to a subscriber of the Purchasing Party, if any Tax is imposed by Applicable Law on the subscriber of the Purchasing Party in connection with its purchase

of the resold Offered Services which the Purchasing Party is required to impose and/or collect from the subscriber, then the Purchasing Party (i) shall impose and/or collect such Tax from the subscriber, and (ii) shall timely remit such Tax to the applicable taxing authority.

27.3.1 If the Providing Party has not received an exemption certificate from the Purchasing Party and fails to collect any Tax as required by Section 27.1, then, as between the Providing Party and the Purchasing Party, (i) the Purchasing Party shall remain liable for such uncollected Tax, and (ii) the Providing Party shall be liable for any interest and/or penalty assessed on the uncollected Tax by the applicable taxing authority.

27.3.2 If the Providing Party properly bills the Purchasing Party for any Tax but the Purchasing Party fails to remit the Tax to the Providing Party as required by Section 27.1, then, as between the Providing Party and the Purchasing Party, the Purchasing Party shall be liable for such uncollected Tax and any interest and/or penalty assessed on the uncollected Tax by the applicable taxing authority. The Providing Party shall give timely notice to the Purchasing Party if any proposed assessment of Taxes, interest or penalties by the applicable taxing authority so as to afford the Purchasing Party an opportunity to cure any defect or inadequacy with its exemption certificate before assessment of any additional Taxes, interest or penalties is made by the taxing authority.

27.3.3 If the Providing Party does not collect a Tax because the Purchasing Party has provided the Providing Party with an exemption certificate which is later found to be inadequate by the applicable taxing authority, then, as between the Providing Party and the Purchasing Party, the Purchasing Party shall be liable for such uncollected Tax and any interest and/or penalty assessed on the uncollected Tax by the applicable taxing authority.

27.3.4 Except as provided in Section 27.3.5, if the Purchasing Party fails to pay the Receipts Tax as required by Section 27.2, then, as between the Providing Party and the Purchasing Party, (i) the Providing Party shall be liable for any Tax imposed on the Providing Party's receipts, and (b) the Purchasing Party shall be liable for any Tax imposed on the Purchasing Party's receipts and any interest and/or penalty assessed by the applicable taxing authority on either the Purchasing Party or the Providing Party with respect to the Tax on the Providing Party's receipts.

27.3.5 If any discount or portion of a discount in price provided to the Purchasing Party under this Agreement (including, but not limited to, the discount provided for in Attachment I) represents Tax savings to the Providing Party which it was assumed the Providing Party would receive, because it was anticipated that receipts from sales of services (that would otherwise be subject to a Tax on such receipts) could be excluded from such Tax under Applicable Law, because the

services would be sold to a Telecommunications Services provider, and the Providing Party is, in fact, required by Applicable Law to pay such Tax on receipts from sales of services to the Purchasing Party, then, as between the Providing Party and the Purchasing Party, the Purchasing Party shall be liable for any such Tax and any interest and/or penalty assessed by the applicable taxing authority on either the Purchasing Party or the Providing Party with respect to the Tax on the Providing Party's receipts.

27.3.6 With respect to any Tax imposed on subscribers of the Purchasing Party that the Purchasing Party is required to collect, as between the Providing Party and the Purchasing Party, the Purchasing Party shall remain liable for such Tax and any interest and/or penalty assessed on such Tax by the applicable taxing authority.

27.4 If either Party is audited by a taxing authority, the other Party agrees to reasonably cooperate with the Party being audited in order to respond to any audit inquiries in a proper and timely manner so that the audit and/or any resulting controversy may be resolved expeditiously.

27.5 If Applicable Law clearly exempts a purchase of services under this Agreement from a Tax, and if such Applicable Law also provides an exemption procedure, such as an exemption certificate requirement, then, if the Purchasing Party complies with such procedure, the Providing Party shall not collect such Tax during the effective period of the exemption. Such exemption shall be effective upon receipt of the exemption certificate or affidavit in accordance with Section 27.7.

27.6 If Applicable Law appears to exempt a purchase of services under this Agreement from a Tax, but does not also provide an exemption procedure, then the Providing Party shall not collect such Tax if the Purchasing Party (i) furnishes the Providing Party with a letter signed by an officer of the Purchasing Party requesting an exemption and citing the provision in the Applicable Law which appears to allow such exemption, and (ii) supplies the Providing Party with an indemnification agreement, reasonably acceptable to the Providing Party, which holds the Providing Party harmless on an after-tax basis with respect to forbearing to collect such Tax.

27.7 All notices, affidavits, exemption certificates or other communications required or permitted to be given by either Party to the other under this Section 27, shall be made in writing and shall be delivered personally or sent by prepaid overnight express service, and sent to the addresses stated in Section 14 and to the following:

To Bell Atlantic: Tax Administration
Bell Atlantic Network Services, Inc.
1717 Arch Street, 30th Floor
Philadelphia, PA 19103

To MCIIm: MCI Carrier Group
MCI Telecommunications Corporation
1133 19th Street, NW
Washington, DC 20036

Either Party may from time-to-time designate another address or addressee by giving notice in accordance with the terms of this Section 27.7. Any notice or other communication shall be deemed to be given when received.

Section 28. Responsibility for Environmental Contamination

28.1 MCIIm shall in no event be liable to Bell Atlantic for any costs whatsoever resulting from a violation of a federal, state or local environmental law by Bell Atlantic, its contractors or agents arising out of this Agreement (a "Bell Atlantic Environmental Violation"). Bell Atlantic shall, at MCIIm's request, indemnify, defend, and hold harmless MCIIm, each of its officers, directors and employees from and against any losses, damages, claims, demands, suits, liabilities, fines, penalties and expenses (including reasonable attorneys fees) that are caused by a Bell Atlantic Environmental Violation.

28.2 Bell Atlantic shall in no event be liable to MCIIm for any costs whatsoever resulting from a violation of a federal, state or local environmental law by MCIIm, its contractors or agents arising out of this Agreement (an "MCIIm Environmental Violation"). MCIIm shall, at Bell Atlantic's request, indemnify, defend, and hold harmless Bell Atlantic, each of its officers, directors and employees from and against any losses, damages, claims, demands, suits, liabilities, fines, penalties and expenses (including reasonable attorneys fees) that are caused by an MCIIm Environmental Violation.

28.3 In the event any suspect materials within Bell Atlantic-owned, operated or leased facilities are identified to be asbestos-containing, MCIIm will ensure that to the extent any activities which it undertakes in the facility disturb such suspect materials, such MCIIm activities will be in accordance with applicable local, state and federal environmental and health and safety statutes and regulations. Except for abatement activities undertaken by MCIIm or equipment placement activities that result in the generation or placement of asbestos containing material, MCIIm shall not have any responsibility for managing, nor be the owner of, not have any liability for, or in connection with, any asbestos containing material at Bell Atlantic-owned, operated or leased facilities. Bell Atlantic agrees to immediately notify MCIIm if Bell Atlantic undertakes any asbestos control or asbestos abatement activities that potentially could affect MCIIm equipment or operations, including, but not limited to, contamination of equipment.

Section 29. Facilities

29.1 A providing Party or its suppliers shall retain all right, title and interest in, and ownership of, all facilities, equipment, software, and wiring, used to provide the

providing Party's services. During the period in which services are provided, the providing Party shall have access at all reasonable times to the purchasing Party's and the purchasing Party's customers' locations for the purpose of installing, maintaining, repairing, and inspecting all facilities, equipment, software, and wiring, used to provide the services. At the conclusion of the period in which services are provided, the providing Party shall have access at the purchasing Party's and the purchasing Party's customers' locations at all reasonable times to remove all facilities, equipment, software, and wiring used to provide the services. The purchasing Party shall, at the purchasing Party's expense, obtain any rights and authorizations necessary for such access.

29.2 Except as otherwise stated in this Agreement or agreed to in writing by a providing Party, a providing Party shall not be responsible for the installation, maintenance, repair or inspection, of facilities, equipment, software, or wiring furnished by the purchasing Party or the purchasing Party's customers for use with the providing Party's services.

Section 30. Option to Obtain Services Under Other Agreements

30.1 In accordance with the requirements of 47 U.S.C. § 252(i), each Party shall, upon written request by the other Party, make available to the requesting Party any interconnection, service, or network element provided under an agreement with a third party, and which is approved by the Commission pursuant to 47 U.S.C. § 252, upon the same terms and conditions (including prices) provided in the agreement with the third party. This Agreement shall thereafter be amended to incorporate the terms and conditions (including prices) from the third party agreement applicable to the interconnection, service, or network element that the requesting Party has elected to purchase pursuant to the terms and conditions of the third party agreement. The amended rates, terms and conditions from the third party agreement shall be effective upon: (i) amendment by the Parties, or (ii) sixty (60) days after the date of written request, whichever is earlier.

30.2 To the extent the exercise of the foregoing option requires a rearrangement of facilities by the providing Party, the requesting Party shall be liable for the non-recurring charges associated therewith, as well as for any termination charges, if any, associated with the termination of existing facilities or services.

Section 31. Other Services

31.1 This Agreement applies only to "services" as defined in this Agreement. To the extent that services subscribed to under this Agreement by a purchasing Party are interconnected to or used with other services, facilities, equipment, software, or wiring, provided by the providing Party or by other persons, such other services, facilities, equipment, software, or wiring, shall not be construed to be provided under this Agreement. Any providing Party services, facilities, equipment, software, or wiring, to be used by the purchasing Party which are not subscribed to by the purchasing Party

under this Agreement must be subscribed to by the purchasing Party separately, pursuant to other written agreements (including, but not limited to, applicable providing Party Tariffs).

31.2 Without in any way limiting Section 31.1, the Parties agree that this Agreement does not apply to the following Bell Atlantic services and products: Bell Atlantic Answer Call, Bell Atlantic Answer Call Plus, Bell Atlantic Basic Mailbox, Bell Atlantic Voice Mail, and other Bell Atlantic voice mail and voice messaging services; Bell Atlantic Optional Wire Maintenance Plan, Bell Atlantic Guardian Enhanced Maintenance Service, Bell Atlantic Sentry I Enhanced Maintenance Service, Bell Atlantic Sentry II Enhanced Maintenance Service, Bell Atlantic Sentry III Enhanced Maintenance Service, and other inside wire maintenance services; customer premises equipment; Telephone Directory advertisements (except as stated in Attachment VIII); and any service that incorporates the payphone station equipment.

31.3 Without in any way limiting Section 31.1 or Section 31.2, the Parties also agree that this Agreement does not apply to the installation, maintenance, repair, inspection, or use of any facilities, equipment, software, or wiring, located on the purchasing Party's side of the Network Rate Demarcation Point applicable to the purchasing Party and does not grant to the purchasing Party a right to installation, maintenance, repair, inspection, or use, of any such facilities, equipment, software, or wiring. Installation, maintenance, repair, inspection, or use of facilities, equipment, software, or wiring, located on the purchasing Party's side of the Network Rate Demarcation Point applicable to the purchasing Party must be contracted for by the purchasing Party separately, pursuant to other written agreements, at rates stated in such other written agreements.

Section 32. Provision and Use of Services

32.1 A Party may fulfill its obligations under this Agreement itself or may cause an Affiliate of the Party to take the action necessary to fulfill the Party's obligations; provided that a Party's use of an Affiliate to perform this Agreement shall not release the Party from any liability or duty to fulfill its obligations under this Agreement.

32.2 Except as otherwise expressly stated in this Agreement, each Party, at its own expense, shall be responsible for obtaining from governmental authorities, property owners, other Telecommunications Carriers, and any other persons or entities, all rights and privileges (including, but not limited to, Rights of Way, space and power), which are necessary for the Party to provide its services pursuant to this Agreement.

32.3 Except as otherwise provided in this Agreement, this Agreement does not prevent a purchasing Party from using the services provided by a providing Party pursuant to this Agreement in connection with other technically compatible services provided by the providing Party pursuant to this Agreement or with any services provided by the purchasing Party or a third party, provided, however, that unless otherwise provided herein, interconnection services, call transport and termination services, and unbundled

Network Elements shall be available under the terms and conditions (including prices) set forth in this Agreement and shall be used by the purchasing Party solely for purposes consistent with obligations set forth in the Act and any rules, regulations or orders thereunder.

Section 33. Selection of IntraLATA Telecommunications Service Provider

33.1 The Parties agree to apply the principles and procedures set forth in Sections 64.1100 and 64.1150 of the FCC Rules, 47 C.F.R. §§ 64.1100 and 64.1150, to the process for end user selection of an IntraLATA Telecommunications Service provider; provided that if the FCC or the Commission adopts rules governing the process for end user selection of an IntraLATA Telecommunications Service provider, the Parties shall apply such rules rather than the principles and procedures set forth in §§ 64.1100 and 64.1150.

33.2 In the event a Party ("Requesting Party") which requests the other Party to change an end user's Telecommunications Service (including, but not limited to, an end user's selection of an IntraLATA Telecommunications Service provider): (a) fails to provide documentary evidence of the end user's IntraLATA Telecommunications Service provider selection upon request; or (b) requests changes in the end user's Telecommunications Service without having obtained authorization for such change from the end user pursuant to the principles and procedures set forth in Sections 64.1100 and 64.1150 or other applicable FCC or Commission rules, the Requesting Party shall indemnify, defend and hold harmless the other Party for any resulting Claims. In addition, the Requesting Party shall be liable to the other Party for all charges that would be applicable to the end user for the initial change in the end user's Telecommunications Service and any charges for restoring the end user's Telecommunications Service to its end user authorized condition, including to the appropriate IntraLATA Telecommunications Service provider.

33.3 A Providing Party shall not require the Purchasing Party to produce a letter of authorization, disconnect order, or other writing, from the Purchasing Party's subscriber as a pre-condition to processing an Order from the Purchasing Party.

Section 34. Service Standards

34.1 Bell Atlantic shall provide service to MCIIm at a level of performance that Bell Atlantic is required by Applicable Law (including 47 U.S.C. § 251) to meet in providing service to MCIIm.

34.2 Bell Atlantic shall offer premium service (services provided at a higher level than that required by Section 34.1) to MCIIm, if MCIIm requests premium service in accordance with Section 25 and MCIIm compensates Bell Atlantic for the incremental cost of providing such premium service.

34.3 Upon MCI's request, Bell Atlantic shall provide to MCI reports on all material measures of service Parity. MCI may request a report on all measures that are reasonably related to establishing the Parity level and whether MCI is receiving services at Parity. Such reports shall indicate for each material measure the service and performance level provided by Bell Atlantic to itself, its Affiliates, MCI, and other CLECs. The reports required by this Section 34 are identified in Attachment X of this Agreement.

34.4 To the extent Bell Atlantic through its Tariffs provides credits for substandard performance, Bell Atlantic shall provide MCI such credits for substandard performance of services provided under this Agreement.

34.5 Pursuant to Section 23 of this Part A, MCI shall have the right, at its expense, to conduct reasonable audits or other verifications of information and reports provided by Bell Atlantic under this Section 34.

Section 35. Subcontracting

35.1 If any obligation under this Agreement is performed through a subcontractor, the subcontracting Party shall remain fully responsible for the performance of this Agreement in accordance with its terms, including any obligations it performs through the subcontractor. The subcontracting Party shall be solely responsible for payments due its subcontractors. No subcontractor shall be deemed a third party beneficiary for any purposes under this Agreement.

Section 36. Amendments and Modifications

36.1 No provision of this Agreement shall be deemed waived, amended or modified by either Party unless such a waiver, amendment or modification is in writing, dated, and signed by both Parties.

Section 37. Severability

37.1 If any term, condition or provision of this Agreement is held to be invalid or unenforceable for any reason, such invalidity or unenforceability shall not invalidate the entire Agreement (unless such construction would be unreasonable), and the Agreement shall be construed as if it did not contain the invalid or unenforceable provision or provisions, and the rights and obligations of each Party construed and enforced accordingly.

Section 38. Headings Not Controlling

38.1 The headings of Articles and Sections of this Agreement are for convenience of reference only, and shall in no way define, modify or restrict the meaning or interpretation of the terms or provisions of this Agreement.

Section 39. Entire Agreement

39.1 This Agreement constitutes the entire agreement between the Parties on the subject matter hereof, and supersedes any prior or contemporaneous agreement, understanding, or representation on the subject matter hereof. Except as otherwise provided in this Agreement, the terms in this Agreement may not be waived or modified except by a written document which is signed by the Parties.

Section 40. Counterparts

40.1 This Agreement may be executed in any number of counterparts, each of which shall be deemed an original; but such counterparts shall together constitute one and the same instrument.

Section 41. Successors and Assigns

41.1 This Agreement shall be binding upon, and inure to the benefit of, the Parties hereto and their respective successors and permitted assigns.

Section 42. Good Faith Performance

42.1 In the performance of their obligations under this Agreement, the Parties shall cooperate fully and act in good faith and consistently with the intent of the Act. Where notice, approval or similar action by a Party is permitted or required by any provision of this Agreement (including, without limitation, the obligation of the Parties to further negotiate the resolution of new or open issues under this Agreement), such action shall not be unreasonably delayed, withheld or conditioned.

Section 43. Joint Work Product

43.1 This Agreement is the joint work product of the representatives of the Parties. For convenience, this Agreement has been drafted in final form by one of the Parties. Accordingly, in the event of ambiguities, no inferences shall be drawn against either Party solely on the basis of authorship of this Agreement.

IN WITNESS WHEREOF, each of the Parties has caused this Agreement to be executed by its duly authorized representatives.

MCImetro Access Transmission Services, Inc.

Bell Atlantic-Pennsylvania, Inc.

By: *Dennis J. Kern*

By: _____

Name: Dennis J. Kern

Name: _____

Title: Vice President

Title: _____

Date: 7/7/97

Date: _____

July 8, 1997

PART A

IN WITNESS WHEREOF, each of the Parties has caused this Agreement to be executed by its duly authorized representatives.

MCImetro Access Transmission Services, Inc.

Bell Atlantic-Pennsylvania, Inc.

By: _____

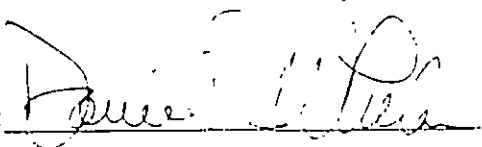
By: 

Name: _____

Name: Daniel J. Whelan

Title: _____

Title: President and CEO

Date: _____

Date: 7/8/97

APPENDIX I

APPENDIX I

TECHNICAL REFERENCE SCHEDULE

Bell Atlantic Technical References

- TR72565. Issue 1, 1996, Bell Atlantic Technical Reference - Basic Unbundled Loop Services - Technical Specifications (as set forth in Exhibit A, Attachment III).
- TR72570. Issue 1, 1996, Bell Atlantic Technical Reference - Analog Unbundled Loop Services with Customer Specified Signaling - Technical Specifications (as set forth in Exhibit B, Attachment III).
- TR72575. Issue 1, 1996, Bell Atlantic Technical Reference - Digital Unbundled Loop Services - Technical Specifications (as set forth in Exhibit C, Attachment III).
- TR72580. Issue 1, 1997, Bell Atlantic Technical Reference - Analog Unbundled Port Services - Technical Specifications (as set forth in Exhibit F, Attachment III).
- TR72585. Issue 1, 1997, Bell Atlantic Technical Reference - Digital Unbundled Port Services - Technical Specifications (as set forth in Exhibit G, Attachment III).
- BA905. Bell Atlantic Supplement Common Channel Signaling Network Interface Specification.

Local Loop

- ANSI/IEEE 743-1995. Standard Methods and Equipment for Measuring the Transmission Characteristics of Analog Voice Frequency Circuits.
- ANSI T1.102-1993. American National Standard for Telecommunication - Digital Hierarchy - Electrical Interfaces.
- ANSI T1.401-1993. American National Standard for Telecommunications - Interface Between Carriers and Customer Installations - Analog Voicegrade Switched Access Lines Using Loop-Start and Ground-Start Signaling
- ANSI T1.403-1995. Network to Customer Installation - DS3 Metallic Interface.
- ANSI T1.405-1996. Network-to-Customer Installation Interfaces - Direct-Inward-Dialing Analog Voice Grade Switched Access Using Loop Reverse-Battery Signaling.
- ANSI T1.601-1992. American National Standard for Telecommunications - ISDN - Basic Access Interface for Use on Metallic Loops for Application at the Network Side of NT, Layer 1 Specification.
- Bellcore TR-NWT-000057. Functional Criteria for Digital Loop Carrier Systems. Issue 2, January 1993.

Local Switching

- Bellcore FR-64-LATA, LATA Switching Systems Generic Requirements ("LSSGR"), 1996 Edition, Issue 1, January 1996.
- Bellcore TR-NWT-000008, Digital Interface Between the SLIC 896 Digital Loop Carrier System and a Local Digital Switch, Issue 2, August 1987; and Revision 1, September 1993; and Bulletin 1, October 1994.
- Bellcore GR-303-CORE, Integrated Digital Loop Carrier System Generic Requirements, Objectives, and Interface, Issue 1, September 1995; and Revision 2, December 1996.
- Bellcore TR-NWT-000393, Generic Requirements for ISDN Basic Access Digital Subscriber Lines, Issue 2, January 1991.

Tandem Switching and Operator Services

- Bellcore TR-TSY-000540, LSSGR: Tandem Supplement, Section 20, Issue 2, July 1987; and Revision 1, December 1988; and Revision 2, June 1990.
- Bellcore GR-1149-CORE, OSSGR Section 10: System Interfaces, Issue 1, October 1995.
- Bellcore GR-1158-CORE, OSSGR Section 22.3: Line Information Database, Issue 2, October 1995.

SS7

- ANSI T1.110-1992, American National Standard Telecommunications - Signaling System Number 7 ("SS7") - General Information.
- ANSI T1.111-1992, American National Standard for Telecommunications - Signaling System Number 7 ("SS7") - Message Transfer Part ("MTP").
- ANSI T1.111A-1994, American National Standard for Telecommunications - Signaling System Number 7 ("SS7") - Message Transfer Part ("MTP") Supplement.
- ANSI T1.112-1992, American National Standard for Telecommunications - Signaling System Number 7 ("SS7") - Signaling Connection Control Part ("SCCP").
- ANSI T1.113-1995, American National Standard for Telecommunications - Signaling System Number 7 ("SS7") - Integrated Services Digital Network ("ISDN") User Part.
- ANSI T1.114-1992, American National Standard for Telecommunications - Signaling System Number 7 ("SS7") - Transaction Capabilities Application Part ("TCAP").
- ANSI T1.115-1990, American National Standard for Telecommunications - Signaling System Number 7 ("SS7") - Monitoring and Measurements for Networks.
- ANSI T1.116-1990, American National Standard for Telecommunications - Signaling System Number 7 ("SS7") - Operations, Maintenance and Administration Part ("OMAP").

- ANSI T1.118-1992. American National Standard for Telecommunications - Signaling System Number 7 ("SS7") - Intermediate Signaling Network Identification ("ISNI").
- Bellecore GR-246-CORE. Bell Communications Research Specification of Signaling System Number 7. Issue 1, December 1994; and Revision 1, December 1995; and Revision 2, December 1996.
- Bellecore GR-317-CORE. Switching System generic requirements for Call Control Using the *Integrated Services Digital Network User Part* ("ISDNUP"). Bellecore. February, 1994
- Bellecore GR-394-CORE. Switching System generic requirements for Interexchange Carrier Interconnection Using the *Integrated Services Digital Network User Part* ("ISDNUP"). Bellecore. February, 1994
- Bellecore GR-905-CORE. Common Channel Signaling Network Interface Specification ("CCSNIS") Supporting Network Interconnection, Message Transfer Part ("MTP"), and *Integrated Services Digital Network User Part* ("ISDNUP"). Issue 2, December 1996.
- Bellecore GR-954-CORE. Common Channel Signaling Network Interface Specification ("CCSNIS") Supporting Line Information Database ("LIDB") Services. Issue 1, June 1994; and Revision 1, October 1995.
- Bellecore GR-1428-CORE. Common Channel Signaling Network Interface Specification ("CCSNIS") Supporting Toll-Free Service. Issue 2, May 1995.
- Bellecore GR-1429-CORE. Common Channel Signaling Network Interface Specification ("CCSNIS") Supporting Call Management Services. Issue 1, August 1994.
- Bellecore GR-1432-CORE. CCS Network Interface Specification ("CCSNIS") Supporting Signaling Connection Control Part ("SCCP") and Transaction Capabilities Application Part ("TCAP"). March 1994.
- Bellecore SR-TSV-002275. BOC Notes on the LEC Networks. Issue 2, April 1994.

AIN

- Bellecore GR-1280-CORE. Advanced Intelligent Network ("AIN") Service Control Point ("SCP") Generic Requirements. Issue 1, August 1993.
- Bellecore TR-NWT-001284. Advanced Intelligent Network ("AIN") 0.1 Switching System Generic Requirements. Issue 1, August 1992, and Bulletin 1, March 1993.
- Bellecore GR-1298-CORE. AINGR: Switching System. Issue 3, July 1996, and Revision 1, November 1996.
- Bellecore GR-1299-CORE. AINGR: Switch Service Control Point ("SCP") Adjunct Interface. Issue 3, July 1996, and revision 1, November 1996.
- Bellecore GR-2863-CORE. CCS Network Interface Specification Supporting Advanced Intelligent Network ("AIN"). Issue 2, December 1995.
- Bellecore GR-2902-CORE. CCS Network Interface Specification ("CCSNIS") Supporting Toll-Free Service Using AIN. Issue 1, May 1995.

Dedicated and Shared Transport

- ANSI T1.101-1994. American National Standard for Telecommunications - Synchronization Interface Standard Performance and Availability.
- ANSI T1.102-1993. American National Standard for Telecommunications - Digital Hierarchy - Electrical Interfaces.
- ANSI T1.105-1995. American National Standard for Telecommunications - Synchronous Optical Network ("SONET") - Basic Description including Multiplex Structure, Rates and Formats.
- ANSI T1.105.01-1995. American National Standard for Telecommunications - Synchronous Optical Network ("SONET") - Automatic Protection Switching.
- ANSI T1.105.02-1995. American National Standard for Telecommunications - Synchronous Optical Network ("SONET") - Payload Mappings.
- ANSI T1.105.03-1994. American National Standard for Telecommunications - Synchronous Optical Network ("SONET") - Jitter at Network Interfaces.
- ANSI T1.105.03a-1995. American National Standard for Telecommunications - Synchronous Optical Network ("SONET"): Jitter at Network Interfaces - DSI Supplement.
- ANSI T1.105.04-1995. American National Standard for Telecommunications - Synchronous Optical Network ("SONET") - Data Communication Channel Protocols and Architectures.
- ANSI T1.105.05-1994. American National Standard for Telecommunications - Synchronous Optical Network ("SONET") - Tandem Connection.
- ANSI T1.105.06-1996. American National Standard for Telecommunications - Synchronous Optical Network ("SONET") - Physical Layer Specifications.
- ANSI T1.106-1988. American National Standard for Telecommunications - Digital Hierarchy - Optical Interface Specifications (Single Mode).
- ANSI T1.107-1988. American National Standard for Telecommunications - Digital Hierarchy - Formats Specifications.
- ANSI T1.107a-1990. American National Standard for Telecommunications - Digital Hierarchy - Supplement to Formats Specifications (DS3 Format Applications).
- ANSI T1.107b-1991. American National Standard for Telecommunications - Digital Hierarchy - Supplement to Formats Specifications.
- ANSI T1.117-1991. American National Standard for Telecommunications - Digital Hierarchy - Optical Interface Specifications ("SONET") (Single Mode - Short Reach).
- ANSI T1.119-1994. American National Standard for Telecommunications - Synchronous Optical Network ("SONET") - Operations, Administration, Maintenance, and Provisioning ("OAM&P") Communications.
- ANSI T1.119.01-1995. American National Standard for Telecommunications - Synchronous Optical Network ("SONET") - Operations, Administration, Maintenance, and Provisioning ("OAM&P") Communications Protection Switching Fragment.
- ANSI T1.231-1993. American National Standard for Telecommunications - Digital Hierarchy - Layer 1 In-Service Digital Transmission performance monitoring.

- ANSI T1.404-1994. Network-to-Customer Installation - DS3 Metallic Interface Specification.
- Bellcore GR-253-CORE. Synchronous Optical Network ("SONET"): Common Generic Criteria. Issue 2. December 1995.
- Bellcore GR-334-CORE. Switched Access Service: Transmission Parameter Limits and Interface Combinations. Issue 1. June 1994.
- Bellcore GR-342-CORE. High-Capacity Digital Special Access Service-Transmission Parameter Limits and Interface Combinations. Issue 1. December 1995.
- Bellcore GR-499-CORE. Transport Systems Generic Requirements ("TSGR"): Common Requirements. Issue 1. December 1995.
- Bellcore TR-NWT-000776. Network Interface Description for ISDN-1 Customer Access. Issue 2. February 1993.
- Bellcore GR-820-CORE. OTGR Section 5.1: Generic Transmission Surveillance. Issue 1. November 1994.

Network Interface Device

- Bellcore GR-49-CORE. Generic Requirements for Outdoor Telephone Network Interface Devices. Issue 1. December 1994.
- Bellcore TA-TSY-000120. Customer Premises or Network Ground Wire. Issue 1. March 1986.
- Bellcore TR-NWT-000239. Generic Requirements for Indoor Telephone Network Interfaces. Issue 2. December 1993.
- Bellcore TR-NWT-000937. Generic Requirements for Building Entrance Terminals. Issue 1. January 1993.

Collocation

- ANSI/NFPA-1996. National Electrical Code ("NEC"), and any standard imposed by the appropriate governing authority having jurisdiction.
- ANSI C2-1997. National Electrical Safety Code.
- Bellcore GR-63-CORE. Network Equipment-Building System ("NEBS") Requirements: Physical Protection. Issue 1. October 1995.
- Bellcore TR-EOP-000151. Generic Requirements for 24-, 48-, 130- and 140- Volt Central Office Power Plant Rectifiers. Issue 1. May 1985.
- Bellcore TR-NWT-000154. General Requirements for 24-, 48-, 130-, and 140- Volt Central Office Power Plant Control and Distribution Equipment. Issue 2. January 1992.
- Bellcore TR-NWT-000295. Isolated Ground Planes: Definition and Application to Telephone Central Offices. Issue 2. July 1992.
- Bellcore TR-NWT-000840. Supplier Support Generic Requirements ("SSGR"). (A Module of LSSGR, FR-NWT-000064). Issue 1. December 1991.

Bellcore GR-1089-CORE. Electromagnetic Compatibility and Electrical Safety - Generic Criteria for Network Telecommunications Equipment, Issue 1, November 1996.
Bellcore TR-NWT-001275 Central Office Environment Installations/Removal Generic Requirements, Issue 1, January 1993.

EXHIBIT A

Bell Atlantic's technician, _____
was here on behalf of your local service provider:

- MCI**
Contact No. (800) 955-7264
- ATX Telecommunications Services**
Contact No. (800) 393-3800
- U.S. Mobile Services, Inc.**
Contact No. (800) 742-0331
- Sprint**
Contact No. (800) 425-0982
- AT&T**
Contact No. (800) 611-2672
- LCI International**
Contact No. (888) 524-0011
- USA eXchange, LLC**
Contact No. (314) 519-4800
- Other:** _____
Contact No. _____

Date: _____ **Time:** _____

Service Order/Tel. Number _____

- All work was completed and your service is now working.
- All work is not yet complete:
 - We need access to your property to complete repair/ installation work. Please call your local service provider and reschedule an appointment.
 - We have checked your service to the entry of your home/business and cannot find any fault or trouble. Please check your phones, wire and equipment for proper operation. (see reverse side of card for instructions)
 - We were able to determine that the trouble is the wire or equipment which belongs to you. We apologize we cannot make these repairs. Please check your wiring and equipment (see reverse side) or call your local service provider for additional instructions.
 - To provide you with service we needed to place a temporary line on the ground. Permanent repairs will be completed in the near future and access to the home/business will not be necessary.
 - We were unable to complete your repair order today due to lack of facilities or equipment. Every effort will be made to resolve this problem as soon as possible. In the event you have questions or need assistance, please call your local service provider.

Remarks: _____

Who is Responsible for Repairs?

You are responsible for the telephones and wiring inside your home/business. You may make repairs yourself or have someone else make the repairs.

Your local service provider is responsible for arranging repair of the outside wiring and has contracted with Bell Atlantic to make some or all of these repairs.

Diagnosing a Problem

Check all of your telephones and equipment to see if they work. If any telephone works, the trouble is more than likely the inside wire, jack, or in your other telephones.

If no telephone works, then you need to plug a working telephone into the Network Interface Device (NID). Some businesses and residence customers have a box installed just inside or outside the place where the telephone wires come into their homes or offices. Inside that box is the NID, which looks like a telephone jack.

The NID separates the telephone company's wiring from yours. By plugging a working telephone into the NID, you can find out where the trouble is.

If the telephone works properly, the problem is in the inside wire, the jacks or in your other telephones or equipment. If the telephone doesn't work, your local service provider is responsible for the problem. In this case, your local service provider should be contacted.

This test could save you the cost of a service call by preventing unnecessary dispatches of service technicians

After checking your telephone and wire, if you still have questions, call your local service provider for additional assistance.

PART B -- DEFINITIONS

"911 Service" or "911" means a universal telephone number which gives the public direct access to the Public Safety Answering Point (PSAP). Basic 911 service collects 911 calls from one or more local exchange switches that serve a geographic area. The calls are then sent to the correct authority designated to receive such calls.

"Access Service Request" (ASR) means the industry standard forms and supporting documentation used for ordering Access Services. The ASR may be used to order trunking and facilities between MCI and Bell Atlantic for local interconnection.

"Access Services" refers to interstate and intrastate switched access and private line transport services.

"Act" means the Communications Act of 1934, as amended.

"Adjunct Equipment" is peripheral equipment housing a database that interfaces with a switch and provides the switch with call processing instructions.

"Advanced Intelligent Network" (AIN) is a network functionality that permits specific conditions to be programmed into a switch which, when met, directs the switch to suspend call processing and to receive special instructions for further call handling in order to enable carriers to offer advanced features and services.

"Affiliate" is an entity that directly or indirectly owns or controls, is owned or controlled by, or is under common ownership or control with, another entity. In this paragraph, "own" means to own an equity interest (or equivalent) of more than ten percent (10%), and "control" means the right to control the business decisions, management and policy of another entity.

"Applicable Law" means all applicable laws and government regulations and orders, including, but not limited to, the regulations and orders of the Federal Communications Commission and the Commission.

"Automated Message Accounting" (AMA) means the structure inherent in switch technology that initially records telecommunication message information. AMA format is contained in the Automated Message Accounting document, published by Bellcore as GR-1100-CORE, which defines the industry standard for message recording.

"Automatic Location Identification" (ALI) is a proprietary database developed for E911 systems that provides for a visual display of the caller's telephone number, address and the names of the emergency response agencies that are responsible for that address. MCI will provide ALI record information in National Emergency Number Association (NENA) Version #2 format. The ALI also shows an Interim Number Portability (INP) number, if applicable.

"Automatic Location Identification Data Management System" (ALI DMS) means the emergency service (E911/911) database containing subscriber location information (including name, address, telephone number, and sometimes special information from the local service provider) used to determine to which PSAP to route the call.

"Automatic Number Identification" (ANI) is a feature that identifies and displays the number of a telephone that originates a call.

"Automatic Route Selection" (ARS) is a CENTREX service feature that provides for automatic selection of the least expensive or most appropriate toll transmission facility for each call based on criteria programmed into the system.

"Bell Atlantic" means Bell Atlantic - Pennsylvania, Inc.

"Bona Fide Request" shall have the meaning set forth in Part A, Section 25.

"CAP" means a competitive access provider.

"CLEC" means a competitive local exchange carrier.

"Calling Party Number" (CPN) is a CCS parameter which refers to the number transmitted through the network identifying the calling party.

"Carrier Access Billing System" (CABS) is defined in a document prepared under the direction of the Billing Committee of the OBF. The Carrier Access Billing System document is published by Bellcore in Volumes 1, 1A, 2, 3, 3A, 4 and 5 as Special Reports SR-OPT-001868, SR-OPT-0011869, SR-OPT-001871, SR-OPT-001872, SR-OPT-001873, SR-OPT-001874, and SR-OPT-001875, respectively, and contains the recommended guidelines for the billing of access and other connectivity services.

"Central Office" or "Central Office Switch" means a switching entity within the public switched network, including, but not limited to, End Office Switches and Tandem Office Switches. Central Office Switches may be employed as combination End Office Tandem Office Switches (Combination Class 5 Class 4).

"CENTREX" means a Telecommunications Service that uses Central Office switching equipment for call routing to handle direct dialing of calls, and to provide numerous private branch exchange-like features.

"Charge Number" is a CCS parameter which refers to the number transmitted through the network identifying the billing number of the calling party.

"CLASS" (Bellcore Service Mark) -- Set of call-management service features that utilize the capability to forward a calling party's number between end offices as part of call setup. Features include automatic callback, automatic recall, caller ID, call trace, and distinctive ringing.

"Collocation" means the right of MCI to place equipment as specified in Attachment V in Bell Atlantic's Central Offices, or other Bell Atlantic locations pursuant to a Bona Fide Request. MCI equipment may be placed via either a physical or virtual collocation arrangement. With physical collocation, MCI obtains dedicated space to place and maintain its equipment. With virtual collocation, Bell Atlantic will install and maintain equipment that MCI provides to Bell Atlantic.

"Combinations" means provision by Bell Atlantic of two or more connected Network Elements ordered by MCI to provide its Telecommunication Services in a geographic area or to a specific subscriber and that are placed on the same order by MCI.

"Commission" means the Pennsylvania Public Utility Commission.

"Common Channel Signaling" (CCS) means a method of digitally transmitting call set-up and network control data over a digital signaling network fully separate from the public switched telephone network that carries the actual call.

"Common Transport" is as defined in Attachment III, Section 9.

"Conduit" means a tube or protected pathway that may be used to house communication or electrical cables. Conduit may be underground or above ground (for example, inside buildings) and may contain one or more inner ducts.

"Confidential Information" has the meaning set forth in Section 22 (Confidentiality) of Part A.

"Control Office" is an exchange carrier center or office designated as its company's single point of contact for the provisioning and maintenance of its portion of local interconnection arrangements.

"Dedicated Transport" is as defined in Attachment III, Section 10.

"Directory Assistance" (DA) or "Directory Assistance Services" provides Directory Listings to callers. Directory Assistance Services may include the option to complete the call at the caller's direction.

"Directory Assistance Database" refers to the database containing subscriber records that is used by Bell Atlantic in its provision of live or automated operator-assisted directory assistance including 411, 555-1212, NPA-555-1212.

"Directory Listings" (DL) refers to subscriber information, including name, address and phone numbers, that is published in any media, including traditional white yellow page directories, specialty directories, CD ROM, and other electronic formats.

"Discloser" means that Party which has disclosed Confidential Information to the other Party.

"Effective Date" is the date indicated in Part A on which the Agreement shall become effective.

"End Office Switch" or "End Office" is a Central Office Switch (Class 5) used to connect subscriber station loops for the purpose of connecting to each other and to trunks.

"Enhanced 911 Service" (E911) means a telephone communication service which will automatically route a call dialed "911" to a designated PSAP attendant and will provide to the attendant the calling party's telephone number and, when possible, the address from which the call is being placed and the emergency response agencies responsible for the location from which the call was dialed.

"Exchange Access" means the offering of access to Telephone Exchange Services or facilities for the purpose of the origination or termination of telephone toll services.

"Exchange Message Record System" (EMR) means the system used among ILECs for exchanging telecommunications message information for billable, non-billable, sample, settlement and study data. EMR format is contained in BR-010-200-010 CRIS Exchange Message Record, published by Bellcore and which defines the industry standard for exchange message records.

"FOC" means firm order confirmation.

"ITC" means an independent telephone company.

"Including" means "including, but not limited to."

"Interconnection Point" (IP) is as defined in Attachment IV.

"Interim Number Portability" (INP) is an interim service arrangement whereby subscribers who change local service providers may retain existing telephone numbers without impairment of quality, reliability, or convenience when remaining at their current location or changing their location within the geographic area served by the initial carrier's serving End Office Switch. INP is provided by the means identified in Attachment VII, Section 2.

"Interexchange Carrier" (IXC) means a provider of interexchange telecommunications Services.

"Line Information Database" (LIDB) is a SCP database that provides for such functions as calling card validation for telephone line number cards issued by ILECs and other entities and validation for collect and billed-to-third services.

"Line Status Verification/Verification and Call Interrupt" (LSV/VCI) means an operator-to-operator call in which the originating operator, on behalf of an end user, inquires as to the busy status of, or requests an interruption of, a call on a Telephone Exchange Service.

"Local Interconnection" is the interconnection of the networks of the Parties for the exchange of Local Traffic and other traffic, in accordance with the requirements of 47 U.S.C. Section 251, and other Applicable Law.

"Local Resale" is as defined in Attachment II.

"Local Switching" is as defined in Attachment III, Section 7.

"Local Traffic" means traffic that is originated by an end user subscriber of one Party on that Party's network and terminates to an end user subscriber of the other Party on that other Party's network within a given local calling area, or expanded area service ("EAS") area, as defined in Bell Atlantic's Tariffs, or, if the Commission has defined local calling areas applicable to all Local Exchange Carriers, then as so defined by the Commission.

"MCIIm" means MCImetro Access Transmission Services, Inc.

"Master Street Address Guide" (MSAG) is a database defining the geographic area of an E911 service. It includes an alphabetical list of the street names, high-low house number ranges, community names, and emergency service numbers provided by the counties or their agents to Bell Atlantic.

"Multiple Exchange Carrier Access Billing" (MECAB) refers to the document prepared by the Billing Committee of the OBF, which functions under the auspices of the Carrier Liaison Committee (CLC) of the Alliance for Telecommunications Industry Solutions (ATIS). The MECAB document, published by Bellcore as Special Report SR-BDS-000983, contains the recommended guidelines for the billing of an access service provided by two or more LECs (including a LEC and a CLEC), or by one LEC in two or more states within a single LATA.

"Multiple Exchange Carriers Ordering and Design" (MECOD) refers to the guidelines for Access Services - Industry Support Interface, a document developed by the Ordering Provisioning Committee under the auspices of the OBF, which functions under the auspices of the Carrier Liaison Committee (CLC) of the Alliance for Telecommunications Industry Solutions (ATIS). The MECOD document, published by Bellcore as Special Report SR STS-002643, establishes recommended guidelines for processing orders for access service which is to be provided by two or more LECs (including a LEC and a CLEC). It is published by Bellcore as SRBDS 00983.

"National Emergency Number Association" (NENA) is an association with a mission to foster the technological advancement, availability and implementation of 911 nationwide.

"Network Element" means a facility or equipment used in the provision of a Telecommunications Service, including features, functions and capabilities that are provided by means of such facility or equipment.

"Network Interface Device" (NID) is as defined in Attachment III, Section 5.

"Network Rate Demarcation Point" shall have the same meaning as "demarcation point" in 47 C.F.R. § 68.3.

"Non-Discriminatory" or "Non-Discriminatory Basis" means that the Party shall perform the obligation or provide the service in question on a non-discriminatory basis for all other Telecommunications Carriers as defined in Section 202(a) of the Act, and/or Section 251 of the Act as applicable.

"North American Numbering Plan" (NANP) means the system or method of telephone numbering employed in the United States, Canada, and certain Caribbean countries. It denotes the three digit Numbering Plan Area code and a seven digit telephone number made up of a three digit Central Office code plus a four digit station number.

"Number Portability" (NP) is a long-term service arrangement whereby users of Telecommunications Services may retain, at the same location, existing Telecommunications numbers without impairment of quality, reliability, or convenience when switching from one Telecommunications Carrier to another.

"Numbering Plan Area" (NPA) (sometimes referred to as an area code) is the three digit indicator which is designated by the first three digits of each 10-digit telephone number within the NANP. Each NPA contains 800 possible NXX Codes. There are two general categories of NPAs: "Geographic NPAs" and "Non-Geographic NPAs." A "Geographic NPA" is associated with a defined geographic area, and all telephone numbers bearing such NPA are associated with services provided within that Geographic area. A "Non-Geographic NPA," also known as a "Service Access Code (SAC Code)" is typically associated with a specialized telecommunications service which may be provided across multiple geographic NPA areas; 500, 800, 900, 700, and 888 are examples of Non-Geographic NPAs.

"NXX" or "NXX Code" is the three digit switch entity indicator which is defined by the fourth, fifth and sixth digits of a 10-digit telephone number within the NANP.

"OCN" means operating company number.

"Operator Services" provides (1) operator handling for call completion (e.g., collect calls); (2) operator or automated assistance for billing after the subscriber has dialed the called number (e.g., credit card calls); and (3) special services (e.g., LSV VCL, Emergency Agency Call).

"Operator Systems" is the Network Element that provides operator and automated call handling with billing, special services, subscriber telephone listings, and optional call completion services.

"Ordering and Billing Forum" (OBF) means the entity which functions under the auspices of the Carrier Liaison Committee (CLC) of the Alliance for Telecommunications Industry Solutions (ATIS).

"Parity" means the following: (i) with respect to a performance requirement for interconnection, that Bell Atlantic will provide interconnection at a level of quality that is equal to that which it provides itself, a subsidiary, an Affiliate, or any other party; (ii) with respect to Local Resale, Bell Atlantic must provide services for resale that are equal in quality, subject to the same conditions, and provided with the same provisioning time intervals that Bell Atlantic provides these services to others, including end users; (iii) with respect to a performance requirement for the provision of a Network Element, that the quality of a Network Element, as well as the quality of the access to such Network Element be the same in quality that Bell Atlantic provides for all Telecommunications Carriers requesting access to that Network Element, and to the extent technically feasible, the quality of a Network Element, as well as the quality of the access to such Network Element, be at least equal in quality to that which Bell Atlantic provides to itself; and (iv) with respect to operational support systems (OSS), Bell Atlantic shall furnish Non-Discriminatory access to OSS functions, and provide access to OSS via electronic interfaces equivalent to that electronic access that Bell Atlantic provides to itself, its Affiliates and its subscribers.

"Party" means a party to this Agreement, either Bell Atlantic or MCIIm.

"Percent Interstate Usage" (PIU) is a calculation which represents the ratio of the interstate toll minutes to the sum of interstate and intrastate toll minutes between exchange carriers sent over Local Interconnection Trunks.

"Percent Local Usage" (PLU) is a calculation which represents the ratio of the Local Traffic minutes to the sum of Local Traffic and intrastate toll minutes between exchange carriers sent over Local Interconnection Trunks. Directory Assistance, LSV VCI, 900, 976, transiting calls from other carriers and switched access calls are not included in the calculation of PLU.

"Point of Interconnection" (POI) is as defined in Attachment IV

"Proprietary Information" shall have the same meaning as Confidential Information.

"Public Safety Answering Point" (PSAP) is the public safety communications center where 911 calls placed by the public for a specific geographic area will be answered.

"RAO" means revenue accounting office.

"Rate Center" means the geographic point and corresponding geographic area which are associated with one or more particular NPA-NXX codes which have been assigned to Bell Atlantic (or MCIIm) for its provision of Telephone Exchange Service. The "Rate Center point" is the finite geographic point identified by a specific V&H coordinate, which is used to measure distance-sensitive end user traffic to/from the particular NPA-NXX designations associated with the specific Rate Center. The "Rate Center area" is the exclusive geographic area identified as the area within which Bell Atlantic (or MCIIm) will provide Telephone Exchange Services bearing the particular NPA-NXX designations associated with the specific Rate Center. The Rate Center point must be located within the Rate Center area.

"Recipient" means that Party to this Agreement (a) to which Confidential Information has been disclosed by the other Party or (b) who has obtained Confidential Information in the course of *providing services under this Agreement*.

"Reciprocal Compensation" refers to a reciprocal compensation arrangement between two carriers in which each of the two carriers receives compensation from the other carrier for the transport and termination on each carrier's network facilities of Local Traffic that originates on the network facilities of the other carrier.

"Remote Switching Module" (RSM) is a switch with the limited capability of switching calls that can be completed between two (2) customers who are each served by unbundled local loops that are provided through the same RSM, *i.e.*, line-to-line switching. A call between a customer who is served by the RSM and a customer who is not served by the RSM must be sent to the host switch.

"Reseller" is a category of local exchange service providers who obtain dial tone and associated Telecommunications Services from another provider through the purchase wholesale priced services for resale to their end user subscribers.

"Right of Way" (ROW) means the right to use the land or other property of another party to place poles, conduits, cables, other structures and equipment, or to provide passage to access such structures and equipment. A ROW may run under, on, or above public or private property (including air space above public or private property) and may include the right to use discrete space in buildings, building complexes or other locations, but does not include inside wire space or structures past the network demarcation point.

"STP" means signaling transfer point.

"Selective Routing" is a service which automatically routes an E911 call to the PSAP that has jurisdictional responsibility for the service address of the telephone that dialed 911, irrespective of telephone company exchange or Wire Center boundaries.

"Service Area Concept" (SAC) is the box where Bell Atlantic cross-connects the Loop Feeder and the Loop Distribution.

"Service Control Point" (SCP) is as defined in Attachment III, Section 13.

"Small Exchange Carrier Access Billing" (SECAB) means the document prepared by the Billing Committee of the OBF. The Small Exchange Carrier Access Billing document, published by Bellcore as Special Report SR OPT-001856, contains the recommended guidelines for the billing of access and other connectivity services.

"Specialized Routing" is as defined in Attachment III, Section 7.2.2.

"Specialized Routing Node" is device that, based on the incoming ANI and the called number, will determine the proper routing for the call and either switch the call to the appropriate Bell Atlantic Operator Services platform or to a designated Point of Interconnection in the originating LATA.

"State" means the Commonwealth of Pennsylvania.

"Switch" -- See Central Office Switch.

"Tandem Office Switches" are Class 4 switches, which are used to connect and switch trunk circuits between and among End Office switches and other tandems.

"Tandem Switching" is as defined in Attachment III, Section 14.

"Tariff" means any generally available schedule of terms, conditions, prices and fees by which Bell Atlantic or MCI/m offers Telecommunication Services for sale to individuals, including subscriber agreements, special offerings and the like.

"Technically Feasible" is as defined in the FCC Interconnection Order. Interconnection, access to unbundled Network Elements, Collocation, and other methods of achieving interconnection or access to unbundled Network Elements at a point in the network shall be deemed technically feasible absent technical or operational concerns that prevent the fulfillment of a request by a Telecommunications Carrier for such interconnection, access, or methods. A determination of technical feasibility does not include consideration of economic, accounting, billing, space, or site concerns, except that space and site concerns may be considered in circumstances where there is no possibility of expanding the space available. The fact that an ILEC must modify its facilities or equipment to respond to such request does not determine whether satisfying such request is technically feasible. An ILEC that claims that it cannot satisfy such request because of adverse network reliability impacts must prove to the state commission by clear and convincing evidence that such interconnection, access, or methods would result in specific and significant adverse network reliability impacts.

"Telecommunications" means the transmission, between or among points specified by the user, of information of the user's choosing, without change in the form or content of the information as sent and received.

"Telecommunications Carrier" means any provider of Telecommunications Services, except that such term does not include aggregators of Telecommunications Services (as defined in Section 226 of the Act). A Telecommunications Carrier shall be treated as a common carrier only to the extent that it is engaged in providing Telecommunications Services, except that the Commission shall determine whether the provision of fixed and mobile satellite service shall be treated as common carriage. This definition includes Commercial Mobile Radio Service providers, INCs and, to the extent they are acting as Telecommunications Carriers, companies that provide both Telecommunications and information services. Private mobile radio service providers are

Telecommunications Carriers to the extent they provide domestic or international Telecommunications for a fee directly to the public.

"Telecommunications Service" means the offering of telecommunications for a fee directly to the public, or to such classes of users as to be effectively available directly to the public, regardless of the facilities used.

"Telephone Exchange Service" means (a) service within a telephone exchange, or within a connected system of telephone exchanges within the same exchange area operated to furnish to subscribers intercommunicating service of the character ordinarily furnished by a single exchange, and which is covered by the exchange service charge, or (b) comparable service provided through a system of Switches, transmission equipment, or other facilities (or combination thereof) by which a subscriber can originate and terminate a Telecommunications Service.

"Unbundled Local Loop" (ULL) is as defined in Attachment III, Section 4.

"Voluntary Federal Subscriber Financial Assistance Programs" are Telecommunications Services provided to low-income subscribers, pursuant to requirements established by the appropriate state regulatory body.

"Wire Center" denotes a building or space within a building which serves as an aggregation point on a given carrier's network, where transmission facilities and circuits are connected or switched. Wire Center can also denote a building in which one or more Central Offices, used for the provision of Telephone Exchange Services and exchange Access Services, are located. However, for purposes of collocation service, Wire Center shall mean those points eligible for such connections as specified in the FCC Docket No. 91-141, and rules adopted pursuant thereto.

TABLE OF CONTENTS

**Attachment I
PRICE SCHEDULE**

| | |
|--|-------|
| Section 1. General Principles | I - 1 |
| Section 2. Network Elements and Call Transport and Termination | I - 2 |
| Section 3. Local Service Resale | I - 2 |
| Section 4. Interconnection and Reciprocal Compensation | I - 2 |
| Section 5. Network Elements | I - 4 |

ATTACHMENT I

PRICE SCHEDULE

Section 1. General Principles

1.1 Subject to Part A, Section 2, all rates and discounts provided under this Agreement shall remain in effect for the term of this Agreement unless modified by order of the FCC or Commission as the case may be, unless otherwise provided herein. The rates and discounts set by the Commission are permanent rates; however, such rates are not set in perpetuity and may be subject to re-examination and investigation by the Commission pursuant to its Final Opinion and Order in the MFS - Phase III Proceeding. To the extent that the rates set forth in Table 1 below reference existing Bell Atlantic or MCIIm Tariffs, those rates shall follow the referenced Tariffs for the term of the Agreement. The rates or discounts set forth in Table 1 below may be subject to change and shall be replaced on a prospective basis (unless otherwise ordered by the FCC, the Commission, or the reviewing court(s)) by such revised rates or discounts as may be ordered approved, or permitted to go into effect by the FCC, the Commission, or a court of applicable jurisdiction, as the case may be. Such new rates or discounts shall be effective immediately upon the legal effectiveness of the court, FCC, or Commission order requiring such new rates or discounts. Within ten (10) days after the legal effectiveness of the court, FCC, or Commission order establishing such new rates or discounts and regardless of any intention by any entity to further challenge such order, the Parties shall sign a document revising Table 1 and setting forth such new rates or discounts, which revised Table 1 the Parties shall update as necessary in accordance with the terms of this Section.

1.2 Rates for Exchange Access Services purchased by either Party for use in the provision of toll service to end user customers are not affected by this Agreement.

1.3 Unless otherwise agreed, MCIIm shall pay only the rates set forth in Table 1 for the services it purchases under this Agreement. Bell Atlantic shall pay for all of the development, modification, technical installation and maintenance of any systems or other infrastructure which it requires to provide the services set forth in this Agreement and priced in Table 1, and shall recover all such costs through the rates set forth in Table 1. Rates for services not yet identified in Table 1, but subsequently developed pursuant to the Bona Fide Request process or services identified in Table 1, but modified by regulatory requirements, shall be added as revisions to Table 1 when agreed between the Parties.

Section 2. Network Elements and Call Transport and Termination

2.1 On the Effective Date, the rates and discounts listed in Table 1 below, including those for: (i) Network Elements; and (ii) call transport and/or termination for Local Traffic purchased for the provision of Telephone Exchange Service or Exchange Access Service, are permanent rates, except as specifically noted herein or in Table 1. These rates may be changed as set forth in Section 1 of this Attachment I.

Section 3. Local Service Resale

3.1 The rates that MCI_m shall pay to Bell Atlantic for Local Resale shall be an amount equal to Tariff rates for each retail Telecommunications Service subject to wholesale pricing, as reduced by the applicable percentage discount set forth in Table 1, if such services are tariffed by Bell Atlantic for sale to subscribers who are not "Telecommunications Carriers" under the Act. If Bell Atlantic revises such tariffed rates during the term of this Agreement, the applicable percentage discount shall be applied to the revised tariffed rates. Unless otherwise specifically agreed between the Parties, no discount shall apply to Bell Atlantic Telecommunications Services that are tariffed by Bell Atlantic for sale to subscribers who are "Telecommunications Carriers" under the Act, which shall be available for resale, or to any Bell Atlantic services other than Telecommunications Services that it may, in its sole discretion, choose to offer for resale.

Section 4. Interconnection and Reciprocal Compensation

4.1 MCI_m may choose to deliver both Local Traffic and toll traffic over the same trunk group(s), pursuant to the provisions of Attachment IV. In the event MCI_m chooses to deliver both types of traffic over the same traffic exchange trunks, and desires application of the local call transport and termination rates, it will provide Percent Local Usage ("PLU") information to Bell Atlantic as set forth in Attachment IV. In the event MCI_m includes both interstate and intrastate toll traffic over the same trunk, it will provide Percent Interstate Usage ("PIU") to Bell Atlantic as set forth in Attachment IV. Bell Atlantic shall have the same options, and to the extent it avails itself of them, the same obligation, to provide PIU and PLU information to MCI_m. To the extent feasible, PLU and PIU information shall be based on the actual end-to-end jurisdictional nature of each call sent over the trunk. If actual PLU and PIU information cannot reasonably be determined, then the reporting Party shall estimate PLU and PIU, and, upon demand, explain the basis for the estimate. The basis for the PLU and PIU are subject to audits in accordance with the provisions of Part A.

4.2 Reciprocal Compensation for the exchange of Local Traffic is set forth in Table 1 of this Attachment and shall be assessed on a per minute-of-use basis for the transport and termination of such traffic.

4.3 MCIIm may choose to establish trunking to any given End Office for calls to numbers served out of that End Office, when there is sufficient traffic to route calls directly to such End Office. If MCIIm leases non-shared trunks from Bell Atlantic, MCIIm will pay the transport charges for dedicated transport. For shared trunks the charges will be shared by both Parties in proportion to their respective use of the shared trunk facility.

4.4 When the Bell Atlantic Interconnection Point is at a Bell Atlantic Tandem Office Switch, MCIIm shall pay Bell Atlantic the rates for Tandem Switching, a transport rate and a termination rate as set forth in Table 1. When the Bell Atlantic Interconnection Point is at the Bell Atlantic End Office, for calls terminating to Bell Atlantic subscribers served out of the End Office to which the traffic is delivered, MCIIm will pay Bell Atlantic call termination compensation based on End Office termination only.

4.5 Bell Atlantic will pay MCIIm a termination rate for termination of traffic at an MCIIm switch based upon the average rate paid by MCIIm to Bell Atlantic during the prior calendar-quarter for the termination of all calls (including both switching and transport).

4.6 Compensation for the termination of toll traffic and the origination of 800 traffic between the interconnecting Parties shall be based on the applicable exchange access charges in accordance with FCC Rules and Regulations.

4.7 Where a toll call is completed through one Party's INP arrangement (e.g., remote call forwarding, flexible DID, etc.) to the second Party's subscriber, the second Party shall be entitled to access charges applicable to the functions performed by the second Party in accordance with FCC Rules and Regulations and as set forth in Attachment VIII, Section 3. Until such time as such access traffic can be measured directly, this access charge pass-through shall be based upon reasonable estimates of the proportion of traffic subject to such pass-through.

4.8 MCIIm shall pay a transit rate as set forth in Table 1 of this Attachment when MCIIm uses a Bell Atlantic Tandem Office to terminate a call to a third party Telecommunications Carrier. Bell Atlantic shall pay MCIIm an equivalent transit rate when Bell Atlantic uses an MCIIm Tandem Office (or functional equivalent) to terminate a call to a third party Telecommunications Carrier.

4.9 Each Party shall exercise all reasonable efforts to enter into reciprocal local traffic exchange arrangements (either via written agreement or mutual tariffs) with any wireless carrier, ITC, or other LEC or CLEC to which it sends, or from which it receives, local traffic that transits Bell Atlantic facilities over traffic exchange trunks. If Party A fails to enter into such an arrangement as quickly as commercially reasonable in a LATA and to provide written notification of such

agreement, including the relevant rates therein, to Party B, but continues to utilize Party B's transit service for the exchange of local traffic with such wireless carrier, ITC, or other LEC or CLEC, Party A shall, in addition to paying the rate set forth in this Attachment I for said transit service, pay Party B any charges or costs such terminating third party carrier imposes or levies on Party B for the delivery or termination of such traffic, including any switched access charges, plus all reasonable expenses incurred by Party B in delivering or terminating such traffic and/or resulting from Party A's failure to secure said reciprocal local traffic exchange arrangement. The Parties will, upon request, provide each other with all reasonable cooperation and assistance in obtaining such arrangements. The Parties agree to work cooperatively in appropriate industry fora to promote the adoption of reasonable industry guidelines relating to transit traffic.

Section 5. Network Elements

The charges that MCI shall pay to Bell Atlantic for Network Elements are set forth in Table 1 of this Attachment I.

TABLE 1

TABLE 1

BELL ATLANTIC-PENNSYLVANIA, INC. AND MCI_m

DETAILED SCHEDULE OF ITEMIZED CHARGES¹

A. Bell Atlantic Services, Facilities, and Arrangements:

| | <u>Bell Atlantic Service</u> | <u>Non-recurring</u> | <u>Recurring</u> |
|------|---|--|---|
| 1.a. | Entrance facilities, and transport per Section 4, as appropriate, for Interconnection at Bell Atlantic End Office, Tandem Office, Serving Wire Center, or other Point of Interconnection Channel Termination | DS-1: Initial Facility: \$668.37 Service Order: \$1.05 Add'l Facility (if purchased at the time of Initial Facility order): \$331.87 DS-3: Initial Facility: \$668.37 Service Order: \$1.05 Add'l Facility (if purchased at the time of Initial Facility order): \$331.87 | DS-1: \$180.59/facility/month DS-3: \$1059.65/facility/month |

¹ Unless a citation is provided to a generally applicable BA tariff, all listed rates and services available only to MCI_m when purchasing these services for use in the provision of Telephone Exchange Service, and apply only to Local Traffic and local ancillary traffic, such as LSV/VCI, Directory Assistance, 911/E911, and Operator Services IntraLATA Call Completion. BA rates and services for use by MCI_m in the carriage of Toll Traffic shall be subject to BA's tariffs for Exchange Access service. Adherence to these limitations is subject to a reasonable periodic audit by BA.

As applied to wholesale discount rates, unbundled Network Elements or call transport and/or termination of Local Traffic purchased for the provision of Telephone Exchange Service or Exchange Access, the rates and charges set forth in Table 1 shall apply until such time as they are replaced by new rates as may be approved or allowed into effect by the Commission from time to time pursuant to the FCC Regulations, subject to a stay or other order issued by any court of competent jurisdiction. At such time(s) as such new rates have been approved or allowed into effect by the Commission, the Parties shall amend Table 1 to reflect the new approved rates.

| | <u>Bell Atlantic Service</u> | <u>Non-recurring</u> | <u>Recurring</u> |
|------|--|--|--|
| | Voice Grade Channel Termination | 2-Wire: Initial Facility: \$497.06 Service Order: \$1.05 Add'l Facility (if purchased at the time of Initial Facility order): \$289.47 | 2-Wire: \$16.78/facility/month |
| | Multiplexing | 4-Wire: Initial Line Install: \$498.73 Service Order: \$1.05 Add'l Facility (if purchased at the time of Initial Facility order): \$290.02 | 4-Wire: \$33.76/facility/month |
| | | DS-3 to DS-1: Initial Line Install: \$548.06 Service Order: \$1.05 Add'l Facility (if purchased at the time of Initial Facility order): \$548.06 | DS-3 to DS-1: \$257.61/facility/month |
| | | DS-1 to Voice Grade: Initial Line Install: \$548.06 Service Order: \$1.05 Add'l Facility (if purchased at the time of Initial Facility order): \$548.06 | DS-1 to Voice Grade: \$77.83/facility/month |
| 1.b. | Collocation and related services for Interconnection at Bell Atlantic End Office, Tandem Office, or Serving Wire Center | Per interstate [Bell Atlantic FCC 1 sec. 19] expanded interconnection tariffs and any applicable charges for unbundled Network Elements per section 3.a. below. | |
| 1.c. | Tandem transit arrangements (for Interconnection between MCI and local carriers other than Bell Atlantic)(IXCs subtending/MPB arrangements excluded) | | |
| | Tandem Switching | Not Applicable | \$0.000836/mou |
| | Transport Fixed | Not Applicable | \$0.000152/mou |
| | Transport per mile | Not Applicable | \$0.000004/mile/mou |
| 1.d. | 911 Interconnection | Per 1.a., 1.b., and 1.c. above, as applicable, for entrance facility plus applicable transport, or Collocation Arrangement at 911 tandem | |
| 1.e. | Directory Assistance Interconnection | Per 7 below. | |

| | <u>Bell Atlantic Service</u> | <u>Non-recurring</u> | <u>Recurring</u> |
|-------------------|---|--|--|
| 1.f. | Operator Services (call completion) Interconnection | Per 7.c. below | |
| 2.a. ² | Poles | Application and Engineering Survey Fee: Actual Full Cost Recovery | Annual Fee: Per BA-PA Tariff 303 Section C Illustrative: Vertical Attachment \$3.98/attachment/year |
| 2.b. | Duct/Innerduct | Application and Engineering Survey Fee: Actual Full Cost Recovery | Annual Fee: As per BA-PA Tariff 303 Section C Illustrative: Per Duct run: \$5.45/foot/year per innerduct: \$3.25/foot/year |
| 2.c. | Conduits | Application and Engineering Survey Fee: Actual Full Cost Recovery | Annual Fee: As per BA-PA Tariff 303 Section C Illustrative: Conduit: \$5.45/foot/year |
| 2.d. | Right of Way | Application and Engineering Survey Fee: Right of Way (determined on a case-by-case basis) | Annual Fee: Right of Way (determined on a case-by-case basis as mutually agreed by the Parties) |
| 3.a. | Local loop transmission Unbundled Local Loop Element and cross-connect to Basic Links ³ | | |

² The rates set forth in 2.a, 2.b, 2.c, and 2.d of this Table are subject to revision by the FCC and/or the Commission in accordance with Section 224 of the Act.

³ Installation charges not applicable when MCI orders both loop and port elements together where BA does not perform an installation function.

| | <u>Bell Atlantic Service</u> | <u>Non-recurring</u> | <u>Recurring</u> |
|--|--|---|--|
| | 2 Wire Analog Loops (POTS Loops) and 2-Wire Customer-Specified Signaling | <p>Line Install, if premises visit not required: Initial loop: \$2.97 Each additional loop: \$2.97</p> <p>Service Order: \$1.05</p> <p>Line Install, if premises visit required: Initial loop: \$66.85 Each additional loop: \$22.59</p> <p>Disconnect: \$1.32/loop</p> <p>Coordinated Cut-Over (only applicable for 2-Wire Customer-Specified Signaling) If premises visit not required: \$3.24/order If premises visit required: \$12.10/order</p> <p>CSS Design (only applicable for 2-Wire Customer-Specified Signaling): \$40.93/order</p> | <p>Density Cell:⁴</p> <p>1 - \$11.52/loop/month 2 - \$12.71/loop/month 3 - \$16.12/loop/month 4 - \$23.11/loop/month</p> |
| | 4-Wire Customer-Specified Signaling | <p>Line Install, if premises visit not required: Initial loop: \$2.97 Each additional loop: \$2.97</p> <p>Service Order: \$1.05</p> <p>Install, if premises visit required: Initial loop: \$66.85 Each additional loop: \$22.59</p> <p>Disconnect: \$1.32/loop</p> <p>Coordinate Cut-Over If premises visit not required: \$3.24/order If premises visit required: \$12.10/order</p> <p>CSS Design: \$40.93/order</p> | <p>Density Cell:</p> <p>1 - \$22.40/month 2 - \$26.36/month 3 - \$33.03/month 4 - \$45.47/month</p> |

⁴ References to Density Cells in 3.a. as per BA-PA Tariffs 1, Section 12A.4, 180A Paragraphs B.4 & B.5, and Paragraph E.2 of Tariffs 182, 182A, 185B, and 185C.

| | <u>Bell Atlantic Service</u> | <u>Non-recurring</u> | <u>Recurring</u> |
|--|---|--|--|
| | ISDN Loops | <p>Line Install, if premises visit not required: Initial loop: \$12.91 Each additional loop: \$12.91</p> <p>Service Order: \$1.05</p> <p>Line Install, if premises visit required: Initial loop: \$76.78 Each additional loop: \$32.52</p> <p>Disconnect: \$1.32/loop</p> | <p>Density Cell: 1 - \$13.16/month 2 - \$14.35/month 3 - \$17.75/month 4 - \$24.74/month</p> |
| | DS-1 Loops | <p>Line Install, if premises visit not required: Initial loop: \$2.97 Each additional loop: \$2.97</p> <p>Service Order: \$1.05</p> <p>Line Install, if premises visit required: Initial loop: \$66.85 Each additional loop: \$22.59</p> <p>Disconnect: \$1.32/loop</p> <p>Coordinate Cut-Over If premises visit not required: \$3.24/order If premises visit required: \$12.10/order</p> <p>CSS Design: \$40.93/order</p> | <p>Density Cell: 1 - \$132.51/month 2 - \$139.37/month 3 - \$168.59/month 4 - \$252.46/month</p> |
| | 2-Wire ADSL Loops ⁵ | TBD | TBD |
| | 2-Wire and 4-wire HDSL Loops ⁶ | TBD | TBD |

⁵ These rates are subject to approval by the Commission.

⁶ These rates are subject to approval by the Commission.

| | <u>Bell Atlantic Service</u> | <u>Non-recurring</u> | <u>Recurring</u> |
|--|----------------------------------|--|--|
| | Collocation Cross-Connect System | | |
| | Voice Grade Loop Cross-Connect | Physical DS0: CO side to equipment: Not Applicable Virtual DS1 w/EDSX ⁷ : Initial Line Install: \$544.36 Service Order: \$1.05 Add'l Line Install: \$210.46 Virtual DS1 w/CFA: Initial Line Install: \$544.36 Service Order: \$1.05 Add'l Line Install: \$210.46 Virtual DS0 w/RFT: Not Applicable | Physical DS0: CO side to equipment: \$0.41/month Virtual DS1 w/EDSX: \$60.21/month Virtual DS1 w/CFA: \$44.08/month Virtual DS0 w/RFT: \$1.20/month |
| | Other Cross-Connect | Physical DS3: Initial Line Install: \$481.36 Service Order: \$1.05 Add'l Line Install: \$194.71 Physical DS1: Initial Line Install: \$481.36 Service Order: \$1.05 Add'l Line Install: \$194.71 Virtual DS3: Initial Line Install: \$481.36 Service Order: \$1.05 Add'l Line Install: \$194.71 Virtual DS1: Initial Line Install: \$481.36 Service Order: \$1.05 Add'l Line Install: \$194.71 | Physical DS3: \$84.27/month Physical DS1: \$15.72/month Virtual DS3: \$88.81/month Virtual DS1: \$16.12/month |

⁷ A Virtual DS1 element with EDSX consists of one (1) DS1 plus twenty-four (24) DS0 with an IDLC.

| | <u>Bell Atlantic Service</u> | <u>Non-recurring</u> | <u>Recurring</u> |
|--------|---|---|--|
| | Digital Cross-Connect System | Service Establishment: \$1890.82 Database Modification: \$148.68/modification request Reconfiguration by BA Personnel: \$31.98/programming charge/30- minute increment DS0 Cross-Connect: \$26.17/port DS1 Cross-Connect: \$32.71/port | Not Applicable Not Applicable Not Applicable DS0 Cross-Connect: \$20.54/port/month DS1 Cross-Connect: \$71.92/port/month |
| 3.b. | Special Construction Charges | As applicable per Bell Atlantic-BA-PA PUC 1 sec. 9 | |
| 3.c.1. | Service Technician Charges (Maintenance Service Charges) (service technician work on unbundled loops outside of the central office) | Service Call-Dispatch and 15 min. labor: \$26.24/premise visit Labor: \$12.10/15-minute increment after first quarter hour Service Order: \$1.05 | Not Applicable |
| 3.c.2. | Central Office Technician Charges | Labor: \$10.42/15-minute increment or fraction thereof Service Order: \$1.05 | Not Applicable |
| 4.a. | Unbundled Dedicated Transport DS-1 | Initial Facility: \$353.70 Service Order: \$1.05 Add'l Facility (if purchased at time of Initial Facility): \$24.00 | \$37.66/facility/month \$0.66/facility/mile/month |
| 4.b. | Unbundled Dedicated Transport DS-3 | Initial Facility: \$353.70 Service Order: \$1.05 Add'l Facility (if purchased at time of Initial Facility): \$24.00 | \$526.72/facility/month \$18.66/facility/mile/month |
| 4.c. | Unbundled Dedicated Transport Voice Grade/DS-0 | Initial Facility: \$353.70 Service Order: \$1.05 Add'l Facility (if purchased at time of Initial Facility): \$24.00 | \$10.37/facility/month \$0.03/facility/mile/month |

| | <u>Bell Atlantic Service</u> | <u>Non-recurring</u> | <u>Recurring</u> |
|------|---|--|--|
| 4.d. | Unbundled Dedicated Transport DDS | Initial Facility: \$353.70 Service Order: \$1.05 Add'l Facility (if purchased at time of Initial Facility): \$24.00 | \$10.74/facility/month \$0.04/facility/mile/month |
| 4.e. | Mid-Span Meet Arrangements | On a case-by-case basis in accordance with Attachment IV. | |
| 4.f. | Common or Shared Transport Tandem Switching Transport Fixed Transport per mile | Not Applicable Not Applicable Not Applicable | \$0.000836/mou \$0.000152/mou \$0.000004/mile/mou |
| 5.a. | Local switching Unbundled Ports POTS/PBX/CENTREX ISDN PRI ISDN BRI Public/Semi-Public DID | Installation: \$2.97/port Service Order: \$1.05/port ⁸ Disconnect: \$1.32/port Installation: \$113.36/port Service Order: \$1.05/port ⁹ Disconnect: \$1.32/port Installation: \$2.97/port Service Order: \$1.05/port ¹⁰ Disconnect: \$1.32/port Installation: \$2.97/port Service Order: \$1.05/port ¹¹ Disconnect: \$1.32/port Installation: \$692.07/port Service Order: \$1.05/port ¹² Disconnect: \$1.32/port | \$2.67/port/month \$135.13/port/month \$10.28/port/month \$3.52/port/month \$5.98/port/month |

⁸ Not applicable when MCI orders both loop and switching elements together where Bell Atlantic does not perform an installation function.

| | <u>Bell Atlantic Service</u> | <u>Non-recurring</u> | <u>Recurring</u> |
|------|--|------------------------------------|--|
| 5.b. | Local switching Unbundled Switching | Not Applicable | Originating (with Vertical Features): \$0.011067/mou Terminating (with Vertical Features): \$0.006143/mou |
| 5.c. | Tandem Switching | Not Applicable | \$0.0008360/mou, plus tandem switched transport as needed |
| 6. | Network Interface Device | Not Applicable | \$0.68/NID/month ¹³ |
| 7.a. | 911 service (data entry; database maintenance) | No charge | |
| 7.b. | Directory Assistance Data | | |
| | Direct Access: | \$32,135.28/link ¹⁴ | \$0.0342/query |
| | Service Establishment: | \$15,206.81/customer ¹⁵ | Not Applicable |

⁹ Not applicable when MCI orders both loop and switching elements together where Bell Atlantic does not perform an installation function.

¹⁰ Not applicable when MCI orders both loop and switching elements together where Bell Atlantic does not perform an installation function.

¹¹ Not applicable when MCI orders both loop and switching elements together where Bell Atlantic does not perform an installation function.

¹² Not applicable when MCI orders both loop and switching elements together where Bell Atlantic does not perform an installation function.

¹³ Not applicable when MCI order a loop element.

¹⁴ This rate is an interim rate until a permanent rate is established by the Commission.

¹⁵ This rate is an interim rate until a permanent rate is established by the Commission.

| | <u>Bell Atlantic Service</u> | <u>Non-recurring</u> | <u>Recurring</u> |
|------|--|---|---|
| 7.c. | Directory Assistance Services/Operator Services | | |
| | Directory Assistance Service | Not Applicable | \$0.3664/call |
| | Directory Transport ¹⁶ Tandem Switching | Not Applicable | \$0.000730/call |
| | Tandem Switched Transport | Not Applicable | \$0.000132/call and \$0.000003/mile/call |
| | Operator Services Live | Not Applicable | \$0.0128/operator work second |
| | Automated ¹⁷ | Not Applicable | \$0.00158/automated work second |
| | Branding ¹⁸ | \$1,358.62/branding message | Not Applicable |
| | Carrier-to-Carrier LSV/VCI Requests | Not Applicable | \$0.01280/operator work second |
| 8.a. | White Pages and Yellow Pages directory listings ¹⁹ | Not Applicable | Not Applicable |
| 8.b. | Books & delivery (annual home area directories only) | No charge for normal numbers of books delivered to end users; bulk deliveries to MCI _m per separate arrangement | |

¹⁶ These rates are interim rates until permanent rates are established by the Commission.

¹⁷ This rate is an interim rate until a permanent rate is established by the Commission.

¹⁸ This rate is an interim rate until a permanent rate is established by the Commission.

¹⁹ These listings refer to primary listings on initial UNE order or resale order. For each residence telephone number, two (2) listings in the White Page directory are provided. For each business telephone number listed (except numbers of CENTREX or CENTREX-like services or dialing service station lines) one (1) listing is provided in the White Page Directory and one (1) listing in the Yellow Page directory of the type provided to BA-PA end user business customers for which no specific charge applies.

| | <u>Bell Atlantic Service</u> | <u>Non-recurring</u> | <u>Recurring</u> |
|-------|--|---|--|
| 8.c. | Additional listings, changes to listings, non-listed, non-published | <p>Per tariff [Bell Atlantic-BA-PA PUC 1 sec. 5.B] less wholesale discount</p> <p><i>Illustrative (non-discounted rates):</i></p> <p>Additional listing: \$12.00 residence; \$15.00 (1st), \$9.00 (additional) business</p> <p>Change to listing: \$12.00 residence; \$15.00 (1st), \$9.00 (additional) business</p> <p>Non-list: \$15.00 residence or business</p> <p>Non-published: \$15.00 residence or business</p> | <p>Per tariff [Bell Atlantic-BA-PA PUC 1 sec. 5.B] less wholesale discount</p> <p><i>Illustrative (non-discounted rates):</i></p> <p>\$1.25/mo residence \$2.05/mo business</p> <p>\$1.25/mo residence or business \$1.75/mo residence or business</p> |
| 9. | Access to telephone numbers (NXX codes issued per ICCF Code Administration Guidelines) | No Charge | |
| 10.a. | <p>SS7 Interconnection</p> <p>STP Port - Termination:</p> <p>STP Port - Access:²⁰</p> | <p>\$94.15/port</p> <p>Service Order: \$1.05/order</p> <p>Initial Facility: \$274.06/facility Add'l Facility: \$24.01/facility</p> | <p>\$640.02/port/month</p> <p>\$0.47/mile/month</p> |
| 10.b. | <p>LIDB Interconnection</p> <p>LIDB Point Codes²¹</p> <p>Calling Card</p> <p>Billed Number Screening</p> <p>Storage of MCI's Data in LIDB Database²²</p> | <p>\$85.84/point code</p> <p>Not Applicable</p> <p>Not Applicable</p> <p>\$1,469.92/service establishment</p> | <p>Not Applicable</p> <p>\$0.015542/query</p> <p>\$0.015542/query</p> <p>Not Applicable</p> |

²⁰ These rates are interim rates until permanent rates are established by the Commission.

²¹ This rate is an interim rate until a permanent rate is established by the Commission.

²² This rate is an interim rate until a permanent rate is established by the Commission.

| | <u>Bell Atlantic Service</u> | <u>Non-recurring</u> | <u>Recurring</u> |
|-------|---|---|---|
| 10.c. | 800/888 data base Interconnection | Not Applicable | Basic Query: \$0.000835/query Vertical Query: \$0.000343/query |
| 11.a. | Interim Number Portability | "Track and True-up" - Once the Commission establishes a rate and cost recovery method, there will be a retroactive true-up with interest charges at the appropriate Commission-determined rate. | |
| 11.b. | Pass-through of access charges under INP arrangement | In accordance with Attachment VIII, Section 3.1.5 | |
| 12. | Local Dialing Parity | No Charge | |
| 13.a. | Reciprocal call termination Local traffic delivered to Bell Atlantic Interconnection Point | Not Applicable | Termination at BA Tandem: \$0.002902/mou Termination at End Office: \$0.001864/mou |
| 13.b. | Access charges for termination of intrastate and interstate toll traffic | Per Bell Atlantic's interstate and intrastate access tariffs (charged in conjunction with Local Traffic, using PLU and PIU, as appropriate) | |
| 14.a. | Local Resale ²³ | Percentage discount from price in retail Tariff ²⁴ | |
| 14.b. | Resale of retail Telecommunications Services where MCI/m does not use Bell Atlantic's Operator Services | 20.69% | |
| 14.c. | Resale of retail Telecommunications Services where MCI/m uses Bell Atlantic's Operator Services | 18.43% | |
| 14.d. | Pennsylvania Gross Receipts Tax discount | Equal to Pennsylvania Gross Receipts Tax (currently 5%) in addition to 14.b or 14.c above | |

²³ The wholesale discounts for the resale of retail telecommunications services excludes Telecommunications Services designed primarily for wholesale, such as switched and special Exchange Access service, and, subject to Attachment II of the Agreement, the following additional arrangements that are not subject to resale: limited duration (90 days or less) promotional offerings, public coin telephone service, and technical and market trials. Taxes shall be collected and remitted by the reseller and BA in accordance with legal requirements and as agreed between the Parties. Surcharges (e.g., 911, telecommunications relay service, universal service fund) shall be collected by the reseller and either remitted to the recipient agency or NECA, or passed through to BA for remittance to the recipient agency or NECA, as appropriate and agreed between the Parties. End user common line charges shall be collected by the reseller and remitted to BA.

²⁴ Pending establishment of mechanized billing procedures adapted to resale, BA will apply the wholesale discount for resale as a "bottom-of-the-bill" discount rate and will utilize a "true-up" process to correct possible inadvertent application of the wholesale discount to the exclusions identified herein and to reflect other adjustments as the Companies agree.

| | <u>Bell Atlantic Service</u> | <u>Non-recurring</u> | <u>Recurring</u> |
|---------|---|---|---|
| 15.a. | Access to Pre-Ordering OSS | Not Applicable | \$0.22/query |
| 15.b. | Access to Ordering OSS | Not Applicable | \$3.34/transaction |
| 15.c. | Access to Provisioning OSS | Not Applicable | No Charge - Included in Ordering |
| 15.d. | Access to Maintenance & Repair OSS | Not Applicable | ECG Access: \$0.22/query EB/OSI Access: \$1.16/trouble ticket |
| 15.e.1. | Access to Billing OSS; CD-ROM | Not Applicable | \$246.59/CD-ROM |
| 15.e.2. | Access to Billing OSS; Daily Usage File Existing Message Recording Existing Message Recording | Not Applicable | \$0.000258/message |
| 15.e.3. | Access to Billing OSS; Daily Usage File Delivery Data Tape Network Data Mover CMDS | \$61.39/programming hour Not Applicable \$61.39/programming hour | \$17.18/tape \$0.000094/message \$0.000094/message |
| 15.e.4. | Access to Billing OSS; Daily Usage File Transport ²⁵ 9.6 kb Communications Port 56 kb Communications Port 256 kb Communications Port T1 Communications Port Line Installation Port Set-up Network Control Programming Coding | Installation: \$7,437.36/port Installation: \$30,778.91/port Installation: \$51,236.88/port Installation: \$182,827.99/port \$61.39/programming hour/port \$9.85/port \$61.39/programming hour/port | \$10.24/port/month \$28.29/port/month \$28.29/port/month \$359.31/port/month Not Applicable Not Applicable Not Applicable |

²⁵ Not applicable to MCI_m if Network Data Mover connectivity has previously been established, and existing facilities are adequate to support transmission of Daily Usage File Data. If additional facilities are required to support transmission of Daily Usage File data, rates TBD.

| | <u>Bell Atlantic Service</u> | <u>Non-recurring</u> | <u>Recurring</u> |
|-----|---|--------------------------------------|--------------------------------------|
| 16. | Customized Routing | | |
| | To MCI _m Platform | \$3.84/line | \$0.142360/line/month |
| | To Bell Atlantic Platform for Re-Branding ²⁶ | \$3.84/line | \$0.08330/call |
| | Customized Routing Transport | See sections 1 & 4 of Table 1 above. | See sections 1 & 4 of Table 1 above. |

²⁶ These rates are interim rates until permanent rates are established by the Commission.

| | Bell Atlantic Service | Non-recurring | Recurring |
|-----|--|-------------------------------|----------------------|
| 17. | AJN Service Creation | | |
| | Developmental Charges Service Establishment: | \$884.08 | Not Applicable |
| | Service Creation Access Port: | Not Applicable | \$123.86/port/month |
| | Service Creation Usage Remote Access: | Not Applicable | \$1328.47/day |
| | On-Premise: | Not Applicable | \$1328.47/day |
| | Certification and Testing | Not Applicable | \$76.99/hour |
| | Help Desk Support | Not Applicable | \$81.48/hour |
| | Service Charges | Not Applicable | \$5.44/month |
| | Subscription Charges: | | |
| | Database Queries | Not Applicable | \$0.0007/query |
| | Network Query: | Not Applicable | \$0.0007/query |
| | MCIIm Network Query: | Not Applicable | \$0.0007/query |
| | MCIIm Switch Query: | Not Applicable | \$0.0007/query |
| | Trigger Charges | Not Applicable | \$0.0010/query |
| | Line-Based: | Not Applicable | \$0.0010/query |
| | Office-Based | Not Applicable | \$0.0003/query |
| | Utilization Element: | | |
| | Service Activation Charge | \$8.37/service activated/line | Not Applicable |
| | Network Service Activation: | | |
| | MCIIm Network Service Activation: | \$8.37/service activated/line | Not Applicable |
| | MCIIm Switch Service Activation: | \$8.37/service activated/line | Not Applicable |
| | Service Modification | Not Applicable | \$0.1080/occurrence |
| | DTMF Update: | Not Applicable | \$0.005/announcement |
| | Switch-Based Announcement: | | |

| | <u>Bell Atlantic Service</u> | <u>Non-recurring</u> | <u>Recurring</u> |
|-----|---|--|----------------------------|
| 18. | Rebundling of Unbundled Services | Pre-existing BA-PA end user: applicable port service order charge (see Section 5 above) Other end users: applicable service order charge for port and installation charges for loop and port (see Sections 3 and 5 above) | See Sections 3 and 5 above |
| 19. | Network Element Recombination Service ²⁷ | TBD | TBD |

²⁷ These rates are subject to approval by the Commission.

B. MCIIm Services, Facilities, and Arrangements:

| | <u>MCIIm Service</u> | <u>Non-recurring</u> | <u>Recurring</u> |
|-----|---|---|---|
| 1.a | Interim Number Portability through co-carrier call forwarding | "Track and True-up" - Once the Commission establishes a rate and cost recovery method, there will be a retroactive true-up with interest charges at the appropriate Commission-determined rate. | |
| 1.b | Pass-through of access charges under INP arrangement | In accordance with Attachment VIII, Section 3.1.5. | |
| 2. | Local Dialing Parity | No charge | |
| 3.a | Reciprocal call termination Local Traffic delivered to MCIIm Interconnection Point | Not Applicable | Average rate paid by BA to MCIIm in the previous calendar quarter ²⁸ |
| 3.b | Access charges for termination of Intrastate and Interstate Toll Traffic | Per MCIIm's interstate and intrastate access Tariffs (charged in conjunction with Local Traffic, using PLU and PIU, as appropriate) | |
| 4.a | Trunk Side transport for Local Interconnection DS-1 trunks | Same rates as set forth in 4.a of Part A. of this Table 1 as may be amended from time to time pursuant to footnote 1 above | |
| 4.b | Trunk Side transport for Local Interconnection DS-3 trunks | Same rates as set forth in 4.b of Part A. of this Table 1 as may be amended from time to time pursuant to footnote 1 above | |
| 5. | All other MCIIm services available to Bell Atlantic | Available at MCIIm's tariffed or otherwise generally available rates or as agreed to by the Parties. | |

²⁸ MCIIm's rates for the termination of BA's Local Traffic shall be recalculated once each year on each anniversary of the Effective Date (the "Rate Determination Date"). The methodology for recalculating the rates is as follows:

Access Tandem Minutes = Total minutes of use of Local Traffic delivered by MCIIm to the BA Access Tandem for most recent billed quarter.

End Office Minutes = Total minutes of use Local Traffic delivered by MCIIm directly to the terminating BA End Office for most recent billed quarter.

Total Minutes = Total minutes of use of Local Traffic delivered by MCIIm to BA for most recent billed quarter.

MCIIm Charge at the MCIIm-IP =

$$\frac{(\text{Access Tandem Minutes} \times \text{BA Tandem Termination Rate } (\$0.002902)) + (\text{End Office Minutes} \times \text{BA End Office Termination Rate } (\$0.001864))}{\text{Total Minutes}}$$

For the first year after the Effective Date, the MCIIm charge shall be calculated based on the traffic data of the quarter immediately preceding such Effective Date, or if no such traffic exists, on the proportion of local call termination trunks to BA End Offices and to BA Access Tandems.

| | <u>MCIm Service</u> | <u>Non-recurring</u> | <u>Recurring</u> |
|----|--|---|------------------|
| 6. | Entrance facilities, and transport, as appropriate, for Local Interconnection at MCIm End Office/Tandem Office, Serving Wire Center, or other Point of Interconnection | Same rates as set forth in I.a. of Part A of this Table I as may be amended from time to time pursuant to footnote 1 above) | |

TABLE OF CONTENTS

**Attachment II
LOCAL RESALE**

| | | |
|------------|---|--------|
| Section 1. | Telecommunications Services Provided for Resale | II - 1 |
| Section 2. | General Terms and Conditions for Resale | II - 1 |
| Section 3. | Service Functions | II - 4 |

ATTACHMENT II

LOCAL RESALE

Section 1. Telecommunications Services Provided for Resale

1.1 In accordance with and subject to the requirements of Applicable Law, Bell Atlantic shall make available to MCIIm for resale any Telecommunications Service that Bell Atlantic currently provides or may offer hereafter, including the service functions described in Section 3 below. Such Telecommunications Services and service functions are collectively referred to as "Local Resale."

1.2 To the extent that this Attachment describes services which Bell Atlantic shall make available to MCIIm for resale pursuant to this Agreement, this list of services is neither all inclusive nor exclusive. All Telecommunications Services which are to be offered for resale are subject to the terms herein.

1.3 Bell Atlantic shall make all of its Telecommunications Services available for resale to MCIIm on terms and conditions that are reasonable and Non-Discriminatory.

1.4 Bell Atlantic will provide services to MCIIm for resale that are equal in quality, subject to the same conditions, and provided within the same provisioning time intervals that Bell Atlantic provides itself, including end users. To the extent applicable, Bell Atlantic shall also conform to the specific requirements of Attachment VIII.

1.5 The specific business process requirements and systems interface requirements are set forth in Attachment VIII.

1.6 Notwithstanding any other provision of this Attachment II, Bell Atlantic shall be entitled to change its Telecommunications Services offerings, subject to the notice provisions of Attachment VIII, Section I.

1.7 MCIIm acknowledges that it has a duty under Section 251(b)(1) of the Act not to prohibit, and not to impose unreasonable and discriminatory conditions or limitations on the resale of its Telecommunications Services. MCIIm will develop its services with the knowledge that when they are available, Bell Atlantic may request negotiations with MCIIm for the resale of such services. MCIIm will negotiate in good faith the terms and conditions necessary for Bell Atlantic to purchase such services for resale from MCIIm.

Section 2. General Terms and Conditions for Resale

2.1 **Pricing.** The prices regarding Local Resale are set forth in Attachment I of this Agreement.

2.2 Restrictions on Resale

2.2.1 Local Resale services may be purchased by MCI_m under this Agreement solely for the purpose of resale by MCI_m. Local services to be purchased for other purposes (including, but not limited to, MCI_m's own use) must be purchased pursuant to separate written agreements, including, but not limited to, applicable Tariffs of Bell Atlantic. MCI_m may purchase Local Resale services under this Agreement for resale to its Affiliates if MCI_m resells such services as a Telecommunications Carrier pursuant to terms and conditions that comply with all applicable Commission rules, including non-discrimination rules.

2.2.2 MCI_m shall not resell Bell Atlantic's residential Local Resale services to customers who are ineligible to subscribe to such Local Resale services from Bell Atlantic.

2.2.3 MCI_m shall not resell Lifeline or any other means-tested service offerings to customers not eligible to subscribe to such service offerings from Bell Atlantic.

2.2.4 MCI_m shall not resell grandfathered Local Resale services to customers who are ineligible to subscribe to such Local Resale services from Bell Atlantic.

2.2.5 The Parties agree to negotiate the applicability of any category-to-category restriction on the resale of Bell Atlantic's Local Resale services that may be offered by Bell Atlantic in the future. If the Parties are unable to reach agreement, the Parties will submit the dispute to the Commission under the dispute resolution procedures of Part A, Section 24 (Dispute Resolution Procedures), and Bell Atlantic shall bear the burden of proving that the category-to-category restriction is reasonable and nondiscriminatory.

2.3 Requirements for Specific Services

2.3.1 CENTREX Requirements

2.3.1.1 MCI_m may purchase CENTREX features (including system management, call forwarding, digital facility termination and ARS), in accordance with applicable Tariffs.

2.3.1.2 All service levels and features of CENTREX service provided by Bell Atlantic for resale by MCI_m shall conform to Bell Atlantic's prevailing service requirements and be at parity with the service and features provided to its end user customers.

2.3.1.3 MCI_m may aggregate multiple MCI_m subscribers on dedicated access facilities. Any aggregation of multiple location subscribers may have the effect of changing the retail CENTREX service offered under

applicable Tariff, in which case MCI must purchase the appropriate tariffed service or, if such changed service is not available under Tariff, the Parties shall attempt to negotiate a separate agreement for such service.

2.3.2 Federal and State Programs

When a Bell Atlantic subscriber eligible for the Voluntary Federal Subscriber Financial Assistance Program or other similar state programs, including Life Line and Link-Up services, chooses to obtain Local Resale from MCI, MCI shall be responsible for obtaining the necessary information for its records regarding such subscriber's eligibility.

2.3.3 Grandfathered Services. Bell Atlantic shall offer for resale to MCI all grandfathered services eligible for resale hereunder. For purposes of this Agreement, a grandfathered service is a service that Bell Atlantic offers to continue for existing retail subscribers of that service, but not to new subscribers.

2.3.4 N11 Service. Bell Atlantic agrees to offer for resale to MCI any N11 Telecommunications Service it offers under Tariff.

2.3.5 Contract Service Arrangements, Special Arrangements, and Promotions. Bell Atlantic shall offer for resale Telecommunications Services, including but not limited to contract service arrangements, special arrangements, and promotions, as required by Applicable Law.

2.3.6 Inside Wire Maintenance Service. [RESERVED]

2.3.7 Voice Mail Service

2.3.7.1 [RESERVED]

2.3.7.2 Bell Atlantic shall make available SMDI-E (Station Message Desk Interface-Enhanced) features where available, or SMDI (Station Message Desk Interface) features where SMDI-E is not available. Bell Atlantic shall make available the MWI (Message Waiting Indicator), stutter dialtone, and message waiting light feature capabilities. Bell Atlantic shall make available CF-B DA (Call Forward on Busy Don't Answer), CF B (Call Forward on Busy), and CF DA (Call Forward Don't Answer) feature capabilities allowing for voice mail services.

2.3.8 Hospitality Service

2.3.8.1 Bell Atlantic shall provide all blocking, screening, and all other applicable functions available for hospitality (e.g., hospitals, hotels and the like) lines, pursuant to Tariff.

2.3.9 Telephone Line Number Calling Cards. Bell Atlantic shall maintain customer information for MCIIm customers who subscribe to resold Bell Atlantic Local Service residential or business dial tone lines in Bell Atlantic's Line Information Database ("LIDB") in the same manner that it maintains information in LIDB on its own similarly situated end user customers. Bell Atlantic shall update and maintain, on the same schedule that it uses for its own similarly situated end user customers, the MCIIm customer information in LIDB.

Section 3. Service Functions

3.1 When Bell Atlantic converts one of its subscribers to MCIIm's service, Bell Atlantic shall inform MCIIm, to the extent such information is available through Bell Atlantic's electronic interfaces for CLECs, whether such subscriber is currently participating in any program of reduced or exempt charges, including those for the indigent, the handicapped, governmental bodies and public institutions.

3.2 Each Party will work cooperatively with the other Party with respect to practices and procedures for handling of law enforcement and service annoyance calls.

3.3 The Parties will cooperate in the development of an industry standard of "700" number test lines.

TABLE OF CONTENTS**Attachment III
NETWORK ELEMENTS**

| | | |
|-------------|--|----------|
| Section 1. | Introduction | III - 1 |
| Section 2. | Unbundled Network Elements | III - 1 |
| Section 3. | Standards for Network Elements | III - 2 |
| Section 4. | Loop | III - 3 |
| Section 5. | Network Interface Device | III - 5 |
| Section 6. | Distribution | III - 7 |
| Section 7. | Local Switching | III - 7 |
| Section 8. | Operator Systems | III - 12 |
| Section 9. | Common Transport | III - 12 |
| Section 10. | Dedicated Transport | III - 13 |
| Section 11. | Signaling Link Transport | III - 16 |
| Section 12. | Signaling Transfer Points ("STPs") | III - 18 |
| Section 13. | Call Related Databases and AIN | III - 21 |
| Section 14. | Tandem Switching | III - 27 |
| Section 15. | Additional Requirements | III - 29 |
| Section 16. | Basic 911 and E911 | III - 35 |
| Section 17. | Directory Assistance Data | III - 35 |
| Exhibit A | FR 72565 | |
| Exhibit B | FR 72570 | |
| Exhibit C | FR 72575 | |
| Exhibit D | Specialized Routing Solution for Operator and DA Calls | |
| Exhibit E | AIN Exception List | |
| Exhibit F | FR 72580 | |
| Exhibit G | FR 72585 | |
| Exhibit H | IntraLATA Telecommunications Services Settlement | |

ATTACHMENT III

NETWORK ELEMENTS

Section 1. Introduction

1.1 Bell Atlantic shall provide unbundled Network Elements in accordance with this Agreement and Applicable Law. The price for each Network Element is set forth in Attachment I of this Agreement. Except as otherwise set forth in this Attachment, MCIIm may order Network Elements as of the Effective Date. The obligations set forth in this Attachment III shall apply to such Network Elements: (i) available when this Agreement becomes effective; (ii) that subsequently become available, and (iii) in all cases to those features, functions, Combinations, and capabilities, the provision of which is Technically Feasible at such time as they are incorporated in unbundled Network Elements offered by Bell Atlantic.

Section 2. Unbundled Network Elements

2.1 Bell Atlantic shall offer Network Elements to MCIIm on an unbundled basis on rates, terms and conditions that are just, reasonable, and Non-Discriminatory in accordance with the terms and conditions of this Agreement.

2.2 Bell Atlantic shall permit MCIIm to connect MCIIm's facilities or facilities provided to MCIIm by third-parties with each of Bell Atlantic's unbundled Network Elements at those generic points within Bell Atlantic's network, designated within this Agreement or as a result of the Bona Fide Request ("BFR") process.

2.3 MCIIm may use one or more Network Element(s) to provide features, functions, or capabilities that such Network Element(s) provide as of the date hereof in Bell Atlantic's network, or as may otherwise be agreed upon through the BFR process.

2.3.1 MCIIm may, at its option, select methods of access to unbundled elements, as described in this Agreement, or as may otherwise be agreed upon through the BFR process.

2.4 Bell Atlantic shall offer each Network Element individually and in Combinations (where Technically Feasible), solely in order to permit MCIIm to provide Telecommunications Services to its subscribers.

2.5 For each Network Element, Bell Atlantic shall provide connectivity at a point which is agreeable to both Parties. However, where Bell Atlantic provides combined Network Elements at MCIIm's request, no connectivity point between the Parties shall exist between such contiguous Network Elements.

2.6 This Attachment describes the initial set of Network Elements which MCI and Bell Atlantic have identified as of the Effective Date of this Agreement:

- Loop
- Network Interface Device
- Local Switching
- Operator Systems
- Common Transport
- Dedicated Transport
- Signaling Link Transport
- Signaling Transfer Points
- Service Control Points/Databases
- Tandem Switching
- Directory Assistance

2.6.1 MCI and Bell Atlantic agree that the Network Elements identified in this Attachment may prove not to be all possible Network Elements.

2.6.2 MCI may identify additional or revised Network Elements as necessary to provide Telecommunications Services to its subscribers, to improve network or service efficiencies or to accommodate changing technologies, subscriber demand, or other requirements.

2.6.2.1 MCI will request any such Network Elements in accordance with the BFR process described in Section 25 (BFR Process for Further Unbundling) of Part A. Additionally, if Bell Atlantic provides any Network Element that is not identified in this Agreement to another CLEC pursuant to an approved Interconnection Agreement, Bell Atlantic shall make available the same Network Element to MCI under the same terms, and conditions, as required by 47 U.S.C. Section 252(i).

Section 3. Technical Standards and Technical Specifications for Network Elements

3.1 Each Network Element shall be furnished at the service levels included in this Agreement and in accordance with the performance standards required in this Agreement.

3.2 Each Network Element provided by Bell Atlantic to MCI, unless identified differently in this Agreement, shall be provided at Parity and in a Non-Discriminatory manner in the areas of: quality of design, performance, features, functions, capabilities and other characteristics, including but not limited to levels and types of redundant equipment and facilities for power, diversity and security, that Bell Atlantic provides to itself (where applicable and Technically Feasible), Bell Atlantic's own subscribers (where applicable and Technically Feasible), to a Bell Atlantic Affiliate, or to any other entity, as set forth in the FCC Rules and Regulations, as the same may be amended from time to time.

3.2.1 Bell Atlantic shall provide to MCI, upon reasonable request, reasonably available engineering, design, performance and other network data sufficient for MCI to determine that the requirements of this Section 3 are being met. In the event that such data indicates that the requirements of this Section 3 are not being met, the Parties shall in good faith endeavor to address the issue at the network operations supervisor level, and if necessary, employ the escalation procedure of Section 15.1.2.

3.2.2 Bell Atlantic agrees to work cooperatively with MCI to ensure that the Network Elements that are provided pursuant to this Agreement will meet MCI's reasonable needs in providing services to its subscribers.

3.3 Unless otherwise requested by MCI, each Network Element and the connections between Network Elements provided by Bell Atlantic to MCI shall be made available to MCI at Parity and in a Non-Discriminatory manner at the points identified in this Agreement, or additional points made available through the BFR process.

Section 4. Loop

4.1 Definition:

4.1.1 Unbundled Local Loop ("ULL") means a transmission path that extends from the vertical side of a main distribution frame, DSX-panel, or functionally comparable piece of equipment in the subscriber's serving End Office to the Network Rate Demarcation Point (or Network Interface Device ("NID") if installed) in or at a subscriber's premises. The actual loop transmission facilities used to provide a ULL may utilize any of several technologies.

4.1.2 Subject to Part A, Section 29 (Facilities), Bell Atlantic shall allow MCI access to the following ULLs (in addition to those ULLs available under applicable Tariffs) including without limitation unprovided from Local Switching and local transport in accordance with the terms and conditions set forth in this Section 4.

4.1.2.1 2-wire analog voice grade ULL, or analog 2W provides an effective 2-wire channel with 2-wire interfaces at each end that is suitable for the transport of analog voice grade (nominal 300 to 3000 Hz) signals and loop-start signaling. The service is more fully described at Exhibit A of this Attachment III.

4.1.2.2 4-wire analog voice grade ULL, or analog 4W provides an effective 4-wire channel with 4-wire interfaces at each end that is suitable for the transport of analog voice grade (nominal 300 to 3000 Hz) signals. The service will operate with one of the following signaling types that may be specified when the service is ordered: loop-start, ground-start,

loop-reverse-battery, duplex, and no signaling. The service is more fully described in Exhibit B of this Attachment III.

4.1.2.3 2-wire ISDN digital grade ULL or BRI ISDN provides a channel with 2-wire interfaces at each end that is suitable for the transport of 160 kbps digital services using the ISDN 2B1Q line code. The service is more fully described in Exhibit C of this Attachment III.

4.1.2.4 4-wire DS-1 compatible ULL provides a channel with 4-wire interfaces at each end. Each 4-wire channel is suitable for the transport of 1.544 mbps digital signals simultaneously in both directions using PCM line code. DS-1 compatible ULLs will be available where existing copper facilities can meet the specifications. The service is more fully described in Exhibit C of this Attachment III.

4.1.2.5 ULLs will be offered on the terms and conditions specified herein and on such other terms in applicable Tariffs that are not inconsistent with the terms and conditions set forth herein.

4.1.3 If Bell Atlantic uses integrated digital loop carrier ("DLC") systems to provide the local loop, Bell Atlantic will make alternate arrangements if available, meeting the requirements of this Section 4, to permit MCI to order an existing contiguous ULL with the same provisioning intervals at no additional cost to MCI. These arrangements may, at Bell Atlantic's option, include the following: provide MCI with copper facilities or universal DLC that are acceptable to MCI. Additional arrangements, such as deployment of Virtual Remote Terminals, or allowing MCI to purchase the entire DLC, are subject to the BFR procedures of Section 25 of Part A of this Agreement.

4.2 Loop Components

MCI may, at its option, raise the issue of subloop unbundling (other than NID unbundling, which is addressed in Section 5 of this Attachment III) either through the BFR procedure set forth in Section 25 of Part A of this Agreement, or by cooperating with Bell Atlantic in the design and implementation of a subloop unbundling technical and operational trial. Loop components may include, but are not limited to, the following:

4.2.1 Loop Concentrator Multiplexer

4.2.2 Loop Feeder

4.2.3 Loop Distribution

Section 5. Network Interface Device

5.1 Definition:

5.1.1 "Network Interface Device" or "NID" means the Bell Atlantic provided interface terminating Bell Atlantic's Telecommunications network on the property where the subscriber's service is delivered at a point determined by Bell Atlantic. The NID contains a FCC Part 68 registered jack from which inside wire may be connected to Bell Atlantic's network.

5.1.2 Bell Atlantic shall permit MCIIm to connect MCIIm's loop to the inside wiring of a subscriber's premises through Bell Atlantic's NID in the manner set forth in Section 5.2 herein.

5.2 Access to Network Interface Device

5.2.1 Due to the wide variety of NIDs utilized by Bell Atlantic (based on subscriber size and environmental considerations), MCIIm may access the subscriber's inside wire by any of the following means:

5.2.1.1 Bell Atlantic shall allow MCIIm to connect its loops directly to Bell Atlantic's multi-line residential NID enclosures that have additional space and are not used by Bell Atlantic or any other Telecommunications Carrier to provide service to the premise. MCIIm agrees to install compatible protectors and test jacks, to maintain the protection system and equipment and to indemnify Bell Atlantic pursuant to Part A of this Agreement.

5.2.1.2 In all other cases, MCIIm must establish the connection to Bell Atlantic's NID through an adjoining NID deployed by MCIIm.

5.2.1.2.1 Where an adequate length of inside wire is present and environmental conditions permit, and with the subscriber authorization required by this Agreement and Applicable Law, either Party may remove the inside wire from the other Party's NID and connect that wire to that Party's own NID; or

5.2.1.2.2 Enter the subscriber access chamber or "side" of "dual chamber" NID enclosures for the purpose of extending a connecterized or spliced jumper wire from the inside wire through a suitable "punch-out" hole of such NID enclosures; or

5.2.1.2.3 Request Bell Atlantic to make other rearrangements to the inside wire terminations or terminal enclosure on a time and materials cost basis to be charged to the requesting Party (*i.e.*,

MCIm, its agent, the building owner or the subscriber). Such charges will be billed to the requesting Party.

5.2.1.3 In no case shall MCIm remove or disconnect Bell Atlantic's loop facilities from Bell Atlantic's NIDs, enclosures, or protectors.

5.2.1.4 In no case shall MCIm remove or disconnect ground wires from Bell Atlantic's NIDs, enclosures, or protectors.

5.2.1.5 In no case shall MCIm remove or disconnect NID modules, protectors, or terminals from Bell Atlantic's NID enclosures.

5.2.1.6 Maintenance and control of premises wiring (inside wire) is the responsibility of the subscriber. Any conflicts between service providers for access to the subscriber inside wire must be resolved by the subscriber.

5.2.1.7 Due to the wide variety of NID enclosures and outside plant environments, Bell Atlantic will work with MCIm to develop specific procedures to establish the most effective means of implementing this Section 5.2.

5.3 Technical Requirements

5.3.1 The NID shall provide an accessible point of connection for the subscriber-owned inside wiring, for Bell Atlantic's facilities, for the distribution media and/or cross connect to MCIm's NID, and shall maintain a connection to ground.

5.3.2 The NID shall be capable of transferring electrical analog or digital signals between the subscriber's inside wiring and the distribution media and/or cross connect to MCIm's NID, consistent with the NID's function at the Effective Date of this Agreement.

5.3.3 Where a Bell Atlantic NID exists, it is provided in its "as is" condition. MCIm may request Bell Atlantic do additional work to the NID in accordance with Section 5.2.1.2.3.

5.4 Interface Requirements

5.4.1 Where an existing Bell Atlantic NID is installed, the NID shall be the interface to subscribers' premises wiring for the existing loop technology at that premises.

Section 6. Distribution

MCIm may, at its option, raise the issue of distribution unbundling through the BFR procedure set forth in Section 25 of Part A of this Agreement.

Section 7. Local Switching

7.1 Definition:

7.1.1 Local Switching is the Network Element that provides MCIm the ability to use switching functionality in a Bell Atlantic end office switch, including all vertical services and/or features that Bell Atlantic already provides, or provides in the future pursuant to the BFR process set forth in Part A, Section 25, out of that switch. MCIm may request modifications to the switching functionality, including the vertical services and/or features, available in a Bell Atlantic end office switch pursuant to the BFR process set forth in Part A, Section 25. Local Switching will be provisioned with a port element, which provides line or trunk side access to Local Switching.

7.1.2 Port element or port means a line card (or equivalent) and associated peripheral equipment on an end office switch which serves as the interconnection between individual loops or individual subscriber trunks and the switching components of an end office switch and the associated switching functionality in that end office switch. Each port is typically associated with one (or more) telephone number(s) which serves as the subscriber's network address. The port element is part of the provision of Local Switching.

7.1.3 Local Switching includes line side and trunk side facilities plus the features, functions, and capabilities of the switch, as set forth in Section 7.1.1. It consists of the line-side port (including connection between a loop termination and a switch line card, telephone number assignment, one primary Directory Listing, presubscription, and access to 911, Operator Services, basic intercept, and Directory Assistance), line and line group features (including appropriate vertical features and line blocking options), usage (including the connection of lines to lines, lines to trunks, trunks to lines, and trunks to trunks), and trunk features (including the connection between the trunk termination and a trunk card). Components of Local Switching, to the extent that they are separately charged, shall be charged at the rates set forth in Attachment I.

7.1.4 Bell Atlantic shall offer, as an optional chargeable feature, daily usage tapes that include the "to and from" number, start time, and stop time, by line port, for all recorded local, access, and toll usage. MCIm may request activation or deactivation of features on a per port basis at any time, and shall compensate Bell Atlantic for the non-recurring charges associated with processing the order.

7.2. Technical Requirements

7.2.1 Bell Atlantic shall route calls to the appropriate trunk or lines for call origination or termination.

7.2.2 Where Technically Feasible, Bell Atlantic will offer Specialized Routing for Local Switching lines and for lines provided to MCI_m under Local Resale. Bell Atlantic's initial deployment of Specialized Routing will route Directory Assistance and Operator Services calls (*i.e.*, 411, 555-1212, 0-, 0-local) to: (i) Bell Atlantic provided platforms; (ii) MCI_m designated platforms; or (iii) third-party platforms. Due to the constraints of the various switches in place in the Bell Atlantic service region, Bell Atlantic will implement a hybrid network solution for Specialized Routing. The hybrid solution encompasses three different technologies: Bell Atlantic's Common Channel Signaling Network/Advanced Intelligent Network (CCSN/AIN) and, for those office and call types not supported by AIN, Specialized Routing Nodes and/or line class codes. The combinations of switch types, call types, and technology solutions currently available are identified in Exhibit D of this Attachment III. Exhibit D is subject to modification upon reasonable prior notification to MCI_m. The following terms and conditions apply to Specialized Routing service:

7.2.2.1 If MCI_m elects the wholesale discount for Local Resale which does not include Bell Atlantic Directory Assistance and Operator Services, MCI_m must request Specialized Routing for all End Offices where they elect to resell Bell Atlantic retail Telecommunications Services using this wholesale discount.

7.2.2.2 Specialized Routing will be activated for all MCI_m Local Resale and Local Switching end user lines and for all applicable call types (*i.e.*, 411, 555-1212, 0-, 0-local) in a requested End Office.

7.2.2.3 MCI_m is responsible for establishing the necessary transport to carry the rerouted calls to its Operator Services platforms. Trunks will be required for traffic rerouted from the originating End Office and for traffic rerouted from the Specialized Routing Node. Bell Atlantic-supplied Dedicated Transport is available for use with Specialized Routing, where facilities are available, in which case rates and charges for such transport will apply in addition to the rates and charges for Specialized Routing.

7.2.2.4 If the necessary trunks are not in place once a subscriber has been converted to MCI_m's local service, then the end user customer will receive a re-order tone.

7.2.2.5 Traffic rerouted via the Specialized Routing Nodes will be handed-off to MCI_m at a Point of Interconnection in the originating LATA.

7.2.2.6 Implementation of Specialized Routing will begin in the requested End Offices in the State no later than ninety (90) days after the beginning of the implementation interval, and will be finished for all requested End Offices in a State within one hundred eighty (180) days after the beginning of the implementation interval. The implementation interval for Specialized Routing will begin upon receipt by Bell Atlantic of a list of the End Offices from which MCI_m wishes to purchase Specialized Routing service.

7.2.2.7 Certain classes of service and/or line types are not supported by AIN-based Specialized Routing. These exceptions, identified in Exhibit E of this Attachment III, will be addressed by Bell Atlantic on a case-by-case BFR basis at MCI_m's request. Additional charges will apply for the development and implementation of the network solution(s) used to address these exceptions. Exhibit E of this Attachment III is subject to modification upon reasonable prior notification to MCI_m.

7.2.2.8 Due to the use of AIN technology for Specialized Routing, some existing and future AIN-based services may not work with Local Resale lines that employ Specialized Routing. Exhibit E of this Attachment III lists AIN services that are currently known to conflict with Specialized Routing.

7.2.3 Bell Atlantic shall provide standard recorded announcements at Parity.

7.2.4 Where requested by MCI_m, Bell Atlantic will attempt to change a subscriber from Bell Atlantic's services to MCI_m's services without loss of feature availability and functionality. However, dependent on the technical arrangements MCI_m chooses to use to provide the end user services, some feature interaction conflicts and resulting loss of feature availability and functionality may result.

7.2.5 For unbundled Bell Atlantic switching in Combination with an unbundled Bell Atlantic loop, Bell Atlantic shall perform routine testing (e.g., mechanized loop tests ("MLT")) at Parity upon receipt of a trouble report from MCI_m.

7.2.6 Bell Atlantic shall repair, restore and maintain Bell Atlantic provided equipment that has produced trouble conditions, at Parity and in a Non-Discriminatory manner, to minimize recurrence of trouble conditions in MCI_m's use of Local Switching.

7.2.7 Bell Atlantic shall control congestion points such as mass calling events, and network routing abnormalities, using capabilities such as automatic call gapping, automatic congestion control, and network routing overflow at Parity and in a Non-Discriminatory manner.

7.2.8 Bell Atlantic shall record billable events, involving usage of the element, and send the appropriate recording data to MCI as outlined in Attachment VIII.

7.2.9 Unbundled switching will include 911 access on the same basis as such access is provided in Bell Atlantic's network.

7.2.10 Bell Atlantic shall provide switching service point ("SSP") capabilities and signaling software to interconnect the signaling links destined to Bell Atlantic STPs at Parity. In the event that Local Switching is provided out of a switch without SS7 capability, and Bell Atlantic unbundled Common Transport is purchased for use with Bell Atlantic's unbundled switching, Bell Atlantic's Tandem Office Switches shall provide this capability at Parity.

7.2.11 Bell Atlantic shall provide interfaces to Adjunct Equipment, which interfaces are identified in this Agreement, at Parity. Bell Atlantic shall provide interfaces to any other Adjunct Equipment at Parity pursuant to the BFR process.

7.2.12 From time to time MCI may request that Bell Atlantic provide unique reports of reasonable performance data regarding a subscriber line, traffic characteristics, or other reasonable elements. To the extent that such reports exceed that which Bell Atlantic provides itself or its subscribers, MCI shall pay reasonable charges for such reports.

7.2.13 Bell Atlantic shall assign each MCI subscriber line an unbundled switching class of service. MCI may request and Bell Atlantic will provide call blocking options (e.g., 900, 976) at Parity.

7.3 Interface Requirements:

7.3.1 Bell Atlantic shall provide the following unbundle switching interfaces:

Analog Basic (POTS) - line side, loop start or ground start signaling

Analog CENTREX - line side, loop start or ground start signaling

Analog PBX - line side, loop start or ground start signaling

Analog DID - trunk side, loop reverse-battery signaling, associated with a PBX

DS1 (DID) - trunk side, associated with a PBX

DS1 (IOF) - trunk side, associated with dedicated unbundled transport

These services will be more fully described in Exhibits F and G of this Attachment III. Additional interfaces may be developed in accordance with the BFR process set forth in Section 25 of Part A of this Agreement.

7.3.2 Bell Atlantic shall offer access to the following at Parity:

7.3.2.1 SS7 signaling or multi-frequency trunking;

7.3.2.2 Interface to MCI^m or Bell Atlantic Operator Services systems through the use of Specialized Routing, as appropriate;

7.3.2.3 Interface to MCI^m or Bell Atlantic Directory Assistance Services through the use of Specialized Routing, as appropriate; and

7.3.2.4 Access to other third-party carriers.

7.4 Integrated Services Digital Network ("ISDN")

Implementation of the first customer application of unbundled ISDN switching will require technical and operational coordination and testing by MCI^m and Bell Atlantic to ensure that the requirements set forth in this section can be met. Should any of these requirements prove technically infeasible, the Parties shall cooperate to determine the requirements applicable to the unbundled service.

7.4.1 Technical Requirements — ISDN

7.4.1.1 Bell Atlantic shall offer data switching providing ISDN that, at a minimum:

7.4.1.1.1 Provides integrated packet handling capabilities at Parity;

7.4.1.1.2 Allows for full 2B-D channel functionality for BRI at Parity; and

7.4.1.1.3 Allows for full 23B-D channel functionality for PRI at Parity;

7.4.1.1.4 Each B channel shall allow for voice, 64 Kbps CSD, and PSD of 128 logical channels at minimum speeds of 19 Kbps throughput of each logical channel up to the total capacity of the B channel.

7.4.1.1.5 Each B channel shall provide capabilities for alternate voice and data on a per call basis.

7.4.1.1.6 The BRI D channel shall allow for call associated signaling, non-call associated signaling and PSD of 16 logical channels at minimum speeds of 9.6 Kbps throughput of each logical channel up to the total capacity of the D channel.

7.4.1.1.7 The PRI D channel shall allow for call associated signaling.

7.4.2 Interface Requirements — ISDN

7.4.2.1 Bell Atlantic shall provide the BRI U interface using 2-wire copper loops in accordance with TR-NWT-000393, January 1991, *Generic Requirements for ISDN Basic Access Digital Subscriber Lines*.

7.4.2.2 Bell Atlantic shall provide the BRI interface using digital subscriber loops adhering to Bellcore TR-NWT-303 specifications to interconnect DLCs.

7.4.2.3 Bell Atlantic shall offer PSD interfaces adhering to the X.25, X.75 and X.75⁺ ANSI and Bellcore requirements.

7.4.2.4 Bell Atlantic shall offer PSD trunk interfaces operating at 56 kbps.

Section 8. Operator Systems

See Attachment VIII, Section 6.1.2 Directory Assistance Service and 6.1.3 Operator Service.

Section 9. Common Transport

9.1 Definition:

9.1.1 Common Transport consists of interoffice transmission paths between Bell Atlantic Network Elements illustrated in Figure 1, shared by carriers. Common Transport consists of Bell Atlantic inter-office transmission facilities and is distinct and separate from Local Switching. Common Transport routes the call between two Bell Atlantic switches using the existing routers that are used by the Bell Atlantic network for Bell Atlantic's end users.

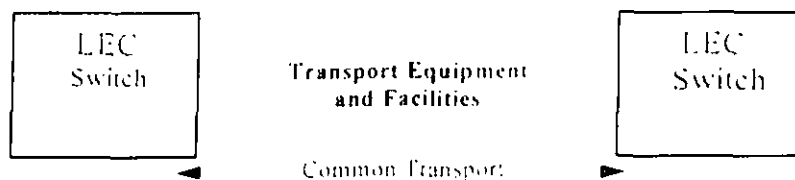

Figure 1

9.2 Technical Requirements

9.2.1 Bell Atlantic shall be responsible for the engineering, provisioning, and maintenance of the underlying equipment and facilities that are used to provide Common Transport.

Section 10. Dedicated Transport

10.1 Definition:

10.1.1 Dedicated Transport is an interoffice transmission path of a fixed capacity between MCI designated locations to which MCI is granted exclusive use. Such locations may include Bell Atlantic Central Offices, other Telecommunication Carrier locations, subscriber premises, or other mutually agreed locations. Dedicated Transport is depicted below in Figure 2.



Figure 2

10.1.2 Bell Atlantic shall offer Dedicated Transport as a circuit (e.g., DS0 (voice grade), DS1, STS1 (when available) and DS3) dedicated to MCI.

10.1.3 When Dedicated Transport is provided as a circuit, it will have available (as appropriate):

10.1.3.1 Optional multiplexing functionality.

10.1.3.2 Grooming functionality in accordance with Section 10.3 herein; and.

10.1.3.3 Redundant equipment and facilities necessary to support protection and restoration at Parity and in a Non-Discriminatory manner.

10.2 Technical Requirements

This Section sets forth technical requirements for all Dedicated Transport.

10.2.1 Dedicated Transport shall provide physical diversity at Parity.

10.2.2 MCI may request that Bell Atlantic provide additional physical diversity. Bell Atlantic will provide such physical diversity where it is available, at Bell Atlantic's prevailing additional charge, if any. If physical diversity is not reasonably available in response to MCI's request, then MCI may order such additional physical diversity by submitting a request for special construction.

10.2.3 Dedicated Transport shall include DSX terminations at one or both ends, as applicable, in Bell Atlantic's Central Office location.

10.2.4 Bell Atlantic shall offer DCS and multiplexing, both together with and separately from Dedicated Transport.

10.3 Digital Cross Connect System ("DCS")

10.3.1 Definition:

10.3.1.1 DCS is a device which provides electronic cross-connection of digital signal level 0 ("DS0") or higher transmission bit rate digital channels within physical interface facilities. Types of DCSs include but are not limited to DCS 10s, where the nomenclature 10 denotes interfaces typically at the DS1 rate or greater with cross-connection typically at the DS0 rate.

10.3.2 DCS Technical Requirements

10.3.2.1 DCS shall provide cross connection of the channels designated by MCI, either through service orders or by using Bell Atlantic's Intellinux capabilities.

10.3.2.2 Bell Atlantic shall continue to administer and maintain DCS, including updates to the control software to current available releases, at Parity.

10.3.2.3 Bell Atlantic shall provide various types of Digital Cross Connect Systems including:

10.3.2.3.1 DS0 cross connects (typically termed DCS 1 0).

10.3.2.3.2 Additional DCS types shall be requested in accordance with the BFR process set forth in Section 25 of Part A of this Agreement.

10.3.2.4 Through Bell Atlantic's Intellimux service capabilities, Bell Atlantic shall provide immediate and continuous configuration and reconfiguration of the channels between the physical interfaces (*i.e.*, Bell Atlantic shall establish the processes to implement cross connects on demand, or permit MCIIm control of such configurations and reconfigurations).

10.3.2.5 Through Bell Atlantic's Intellimux service capabilities, Bell Atlantic shall provide scheduled configuration and reconfiguration of the channels between the physical interfaces (*i.e.*, Bell Atlantic shall establish the processes to implement cross connects on the schedule designated by MCIIm, or permit MCIIm to control such configurations and reconfigurations).

10.3.2.6 DCS shall continuously monitor protected circuit packs and redundant common equipment at Parity.

10.3.2.7 DCS shall automatically switch to a protection circuit pack on detection of a failure or degradation of normal operation at Parity.

10.3.2.8 The equipment used to provide DCS shall be equipped with a redundant power supply or a battery back-up at Parity.

10.3.2.9 Bell Atlantic shall make available for DCSs handling MCIIm services spare facilities and equipment at Parity, necessary for provisioning repairs.

10.3.2.10 Through Bell Atlantic's Intellimux service capabilities, at MCIIm's option, Bell Atlantic shall provide MCIIm currently available performance monitoring and alarm data.

10.3.2.11 At MCIIm's option, Bell Atlantic shall provide MCIIm with the ability to initiate tests on DCS equipment. This will require MCIIm to provide additional facilities from the DCS, back to MCIIm's test center. The DCS can then be used to connect MCIIm's test center ports to other MCIIm circuits.

10.3.2.12 Where available, DCS shall provide multipoint bridging of multiple channels to other DCSs. MCIIm may designate multipoint bridging to be one-way broadcast from a single master to multiple tributaries, or two-way broadcast between a single master and multiple tributaries.

10.3.2.13 DCS shall multiplex lower speed channels onto a higher speed interface and demultiplex higher speed channels onto lower speed interfaces as designated by MCIIm.

Section 11. Signaling Link Transport

11.1 Definition:

11.1.1 Bell Atlantic's CCS Access Service ("CCSAS") allows interconnected carriers to exchange signaling information over a communications path which is separate from the message path. The transport portion of CCSAS is provided via a discretely rated dedicated 56 kbps out of band signaling connection between the carrier's Signaling Point of Interconnection ("SPOI") and Bell Atlantic's STP.

11.1.2 Each CCSAS signaling connection provides one or two-way digital transmission at speeds of 56 kbps. The connection to Bell Atlantic's STP pair can be made from either the carrier's signaling point ("SP"), which requires a minimum of two 56 kbps circuits, or from the carrier's STP pair, which requires a minimum of four (4) pairs of 56 kbps circuits.

11.1.3 STP locations are set forth in National Exchange Carrier Association ("NECA") Tariff F.C.C. No. 4. Carriers ordering CCSAS are subject to the technical requirements specified in Bell Atlantic Tariff F.C.C. No. 1, Sections 2.3.9.1, 2.3.10 (B) (9) and 2.3.10 (9). Testing and certification reference documentation shall be pursuant to Bell Atlantic Tariff F.C.C. No. 1, Section 6.4.3 (A).

11.1.4 Each Party shall provide the other Party with access to databases and associated signaling necessary for call routing and completion by providing SS7 CCS interconnection in accordance with existing Tariffs, and interconnection and access to toll free databases, LIDB, and any other necessary databases in accordance with existing Tariffs and/or agreements with other unaffiliated carriers. Alternatively, either Party may secure CCS interconnection from a commercial SS7 hub provider, and in that case the other Party will permit the purchasing Party to access the same databases as would have been accessible if the purchasing Party had connected via SS7 CCS directly to the other Party's CCS network.

11.1.5 Bell Atlantic shall permit MCI to access Bell Atlantic's LIDB to validate calling card numbers and requests for bill-to-third-party or collect billing. Bell Atlantic shall provide LIDB access at Parity and in a Non-Discriminatory manner by a SS7 formatted data query before call completion to determine the validity of the billing method requested by the caller. LIDB will respond with a SS7 formatted confirmation of validity or denial of the requested billing option.

11.1.6 The Parties will provide CCS Signaling to one another, where and as available, *in conjunction with all local traffic, toll traffic, meet point billing traffic, and transit traffic.* The Parties will cooperate on the exchange of TCAP messages to facilitate interoperability of CCS-based features between their respective networks, *including all CLASS features and functions, to the extent each Party offers such features and functions to its subscribers.* All CCS signaling parameters will be provided upon request (where available), including called party number, Calling Party Number, originating line information, calling party category, and Charge Number. All privacy indicators will be honored. The Parties will follow all relevant OBF adopted standards pertaining to CICOZZ codes. Where CCS Signaling is not available, in-band multi-frequency ("MF") wink start signaling will be provided. Any such MF arrangement will require a separate local trunk circuit between the Parties' respective Switches. In such an arrangement, each Party will output the full ten-digit telephone number of the called party to the other party with appropriate call set-up and ANI where available, at Parity.

11.1.7 The following publications describe the practices, procedures and specifications generally utilized by Bell Atlantic for signaling purposes and is listed herein to assist the Parties in meeting their respective interconnection responsibilities related to signaling:

11.1.7.1 Bellcore GR-905-CORE, Issue 1, March 1995, and subsequent issues and revisions;

11.1.7.2 Bell Atlantic Supplement Comar: Channel Signaling Network Interface Specification, Bell Atlantic-905, December 1990; Issue, Supplement 1, June 1992; Supplement 2, 3, 2/8/1992; Supplement 3, January 1993; and

11.1.7.3 Bell Atlantic AIN SMS Network Disclosure (Date: December 1996, on Bell Atlantic World Wide Web site)

11.1.8 Each Party shall charge the other Party mutual and reciprocal rates for CCS Signaling as follows: Bell Atlantic shall charge MCI in accordance with Attachment I hereto and applicable Tariffs; MCI shall charge Bell Atlantic rates equal to the rates Bell Atlantic charges MCI, unless MCI's Tariffs for CCS

signaling provide for lower generally available rates, in which case MCI shall charge Bell Atlantic such lower rates.

11.1.9 MCI must meet interconnection certification testing requirements of the SS7 network before interconnection is permitted, and also before changes occur within the MCI SS7 network.

Section 12. Signaling Transfer Points ("STPs")

12.1 Definition:

12.1.1 Bell Atlantic's CCSAS allows interconnected carriers to exchange signaling information over a communications path which is separate from the message path. The discretely rated network termination point where this interconnection takes place is called the Bell Atlantic STP port termination. Figure 3 depicts STPs.

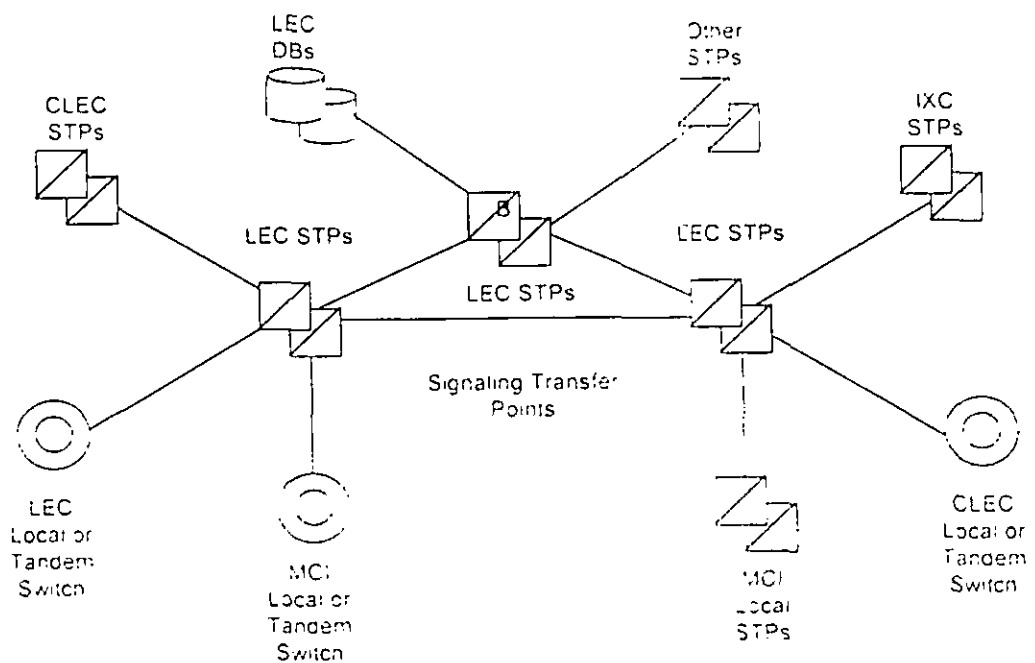

Figure 3

12.1.2 Each CCSAS signaling connection provides for two-way digital transmission at speeds of 56 kbps. The connection to Bell Atlantic's STP pair can be made from either the carrier's STP, which requires a minimum of two (2) 56

kbps circuits, or from the carrier's STP pair, which requires a minimum of four (4) pairs of 56 kbps circuits.

12.1.3 STP locations are set forth in National Exchange Carrier Association ("NECA") Tariff F.C.C. No. 4. Carriers ordering CCSAS are subject to the technical requirements specified in Bell Atlantic Tariff F.C.C. No. 1, Sections 2.3.9.1, 2.3.10 (B) (9) and 2.3.10 (9). See Bell Atlantic Tariff F.C.C. No. 1, Section 6.4.3 (A) for testing and certification reference documentation).

12.2 Technical Requirements

12.2.1 STPs shall provide access to all other Network Elements connected to the Bell Atlantic network. These include:

12.2.1.1 Bell Atlantic Local Switching or Tandem Switching;

12.2.1.2 Bell Atlantic Service Control Points databases;

12.2.1.3 Third-party local or Tandem Switching systems; and

12.2.1.4 Third-party-provided STPs.

12.2.2 The connectivity provided by STPs shall fully support the functions of all other Network Elements connected to the Bell Atlantic SS7 network. This explicitly includes the use of the Bell Atlantic SS7 network to convey messages which neither originate nor terminate at a signaling end point directly connected to the Bell Atlantic SS7 network (*i.e.*, transit messages). When the Bell Atlantic SS7 network is used to convey transit messages, there shall be no alteration of the integrated services digital network user part ("ISDN UP") or Transaction Capabilities Application Part ("TCAP") user data that constitutes the content of the message.

12.2.3 If a Bell Atlantic Tandem Switch routes calling traffic, based on dialed or translated digits, on SS7 trunks between an MCI local Switch and third-party local Switch, Bell Atlantic's SS7 network shall convey the TCAP messages that are necessary to provide call management features (automatic callback, automatic recall, and screening list editing) between the MCI local STPs and the STPs that provide connectivity with the third-party local Switch, even if the third-party local Switch is not directly connected to Bell Atlantic's STPs, providing that the third-party Switch is located in the same LATA.

12.2.4 In cases where the destination signaling point is a Bell Atlantic local or Tandem Switching system or database, or is an MCI or third-party local or Tandem Switching system directly connected to Bell Atlantic's SS7 network, Bell Atlantic STPs shall perform final GTT of messages to the destination and SCCP

Subsystem Management of the destination. In all other cases, STPs shall perform intermediate GTT of messages to a gateway pair of STPs in an SS7 network connected with the Bell Atlantic SS7 network, and shall not perform SCCP subsystem management of the destination.

12.3 Interface Requirements

12.3.1 Bell Atlantic shall provide the following STPs options to connect MCI or MCI-designated Local Switching systems or STPs to the Bell Atlantic SS7 network:

12.3.1.1 An A-link interface from MCI (Local Switching systems) and

12.3.2 Each type of interface shall be provided by one or more sets (layers) of signaling links, as follows:

12.3.2.1 An A-link layer shall consist of two links, as depicted in Figure 4.

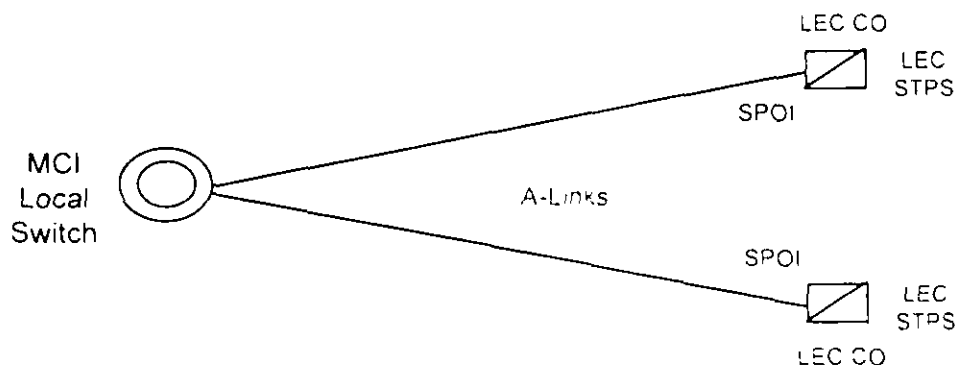

Figure 4. A-Link Interface

12.3.3 The Signaling Point of Interconnection ("SPOI") for each link shall be located at a cross-connect element, such as a DSX-1, in the Central Office where the Bell Atlantic STP is located. There shall be a DS1 or higher rate transport interface at each of the SPOIs. Each signaling link shall appear as a DS0 channel within the DS1 or higher rate interface.

12.4 Message Screening

12.4.1 Bell Atlantic shall set message screening parameters so as to accept messages from MCI local or tandem switching systems destined to any

signaling point in the Bell Atlantic SS7 network with which the MCIIm switching system has a legitimate signaling relation.

12.4.2 Bell Atlantic shall set message screening parameters so as to accept messages from MCIIm local or tandem switching systems destined to any signaling point or network interconnected to the Bell Atlantic SS7 network with which the MCIIm switching system has a legitimate signaling relation.

12.4.3 Bell Atlantic shall set message screening parameters so as to accept messages destined to an MCIIm local or tandem switching system from any signaling point or network interconnected to the Bell Atlantic SS7 network with which the MCIIm switching system has a legitimate signaling relation.

12.4.4 Bell Atlantic shall set message screening parameters so as to accept and send messages destined to an MCIIm SCP from any signaling point or network interconnected to the Bell Atlantic SS7 network with which the MCIIm SCP has a legitimate signaling relation, provided Bell Atlantic receives proper notification and agreement from the owner of such other networks.

12.5 STP Requirements

12.5.1 Bell Atlantic shall provide MTP and SCCP protocol interfaces in accordance with sections relevant to the MTP or SCCP in the following specifications:

12.5.1.1 Bellecore GR-905-CORE, Issue 1, March 1, Common Channel Signaling Network Interface Specification ("CCSNIS") Supporting Network Interconnection, Message Transfer Part ("MTP"), and Integrated Services Digital Network User Part ("ISDNUP"); and

Section 13. Call Related Databases and AIN

13.1 Definition:

13.1.1 "Call Related Databases" are the Network Elements that provide the functionality for storage of, and access to, information required to route and complete a particular call. Call Related Databases include, but are not limited to: LIDB, Toll Free Number Database, and AIN databases.

13.1.2 A Service Control Point ("SCP") is a specific type of database Network Element deployed in a Signaling System 7 ("SS7") network that executes service application logic in response to SS7 queries sent to it by a switching system also connected to the SS7 network.

13.2 Technical Requirements for Call Related Databases

Requirements for Call Related Databases within this section address storage of information, access to information (e.g., signaling protocols, response times), and administration of information (e.g., provisioning, administration, and maintenance). All Call Related Databases shall be provided to MCIm in accordance with the following requirements, except where such a requirement is superseded by specific requirements set forth in Subsections 13.3 through 13.5:

13.2.1 Bell Atlantic shall provide physical interconnection to SCPs through the SS7 network and protocols, as specified in Section 12 of this Attachment, with TCAP as the application layer protocol.

13.2.2 Bell Atlantic shall provide physical interconnection to databases via existing interfaces and industry standard interfaces and protocols (e.g., 56 Kb TCP/IP).

13.2.3 The reliability of interconnection options shall be consistent with requirements for diversity and survivability as specified in Section 12 of this Attachment (which applies to both SS7 and non-SS7 interfaces).

13.2.4 Call Related Database functionality shall be available at Parity. If, based on information available through the process set forth in Section 3, MCIm believes the functionality is inadequate to meet its needs, it may initiate a BFR.

13.2.5 Bell Atlantic shall complete database transactions (i.e., add, modify, delete) for MCIm subscriber records stored in Bell Atlantic databases at Parity.

13.2.6 Bell Atlantic shall provide database maintenance consistent with the maintenance requirements as specified in this Agreement (e.g., notification of Bell Atlantic network affecting events, testing).

13.2.7 Bell Atlantic shall provide billing and recording information to track database usage consistent with connectivity billing and recording requirements for Call Related Databases as specified in this Agreement (e.g., recorded message format and content, timeliness of feed, data format and transmission medium).

13.2.8 Bell Atlantic shall provide Call Related Databases in accordance with the physical security requirements specified in this Agreement.

13.2.9 Bell Atlantic shall provide Call Related Databases in accordance with the logical security requirements specified in this Agreement.

13.3 Line Information Database ("LIDB")

This Subsection 13.3 defines and sets forth additional requirements for the Line Information Database. This Subsection 13.3 supplements the requirements of Subsection 13.2 and 13.5.

13.3.1 Definition:

LIDB is a transaction-oriented database accessible through CCS networks. It contains records associated with subscriber line numbers and special billing numbers (in accordance with the requirements in the technical reference in GR-1158-CORE OSSGR, Section 22.3). LIDB accepts queries from other Network Elements, or MCI's network, and provides appropriate responses. The query originator need not be the owner of LIDB data. LIDB queries include functions such as screening billed numbers that provides the ability to accept collect or third number billing calls and validation of telephone line number based non-proprietary calling cards. The interface for the LIDB functionality is the interface between the Bell Atlantic CCS network and other CCS networks. LIDB also interfaces to administrative systems. The administrative system interface provides Bell Atlantic work centers with an interface to LIDB for functions such as provisioning, auditing of data, access to LIDB measurements and reports.

13.3.2 Technical Requirements

13.3.2.1 Prior to the availability of a long-term solution for NP, Bell Atlantic shall enable MCI to store in Bell Atlantic's LIDB any subscriber line number or special billing number record, (in accordance with the technical reference in GR-1158-CORE OSSGR, Section 22.3) whether ported or not, for which the NPA-XXX or XXX-0 1XX group is supported by that LIDB.

13.3.2.2 Prior to the availability of a long-term solution for NP, Bell Atlantic shall enable MCI to store in Bell Atlantic's LIDB any subscriber line number or special billing number (in accordance with the technical reference in GR-1158-CORE OSSGR, Section 22.3) record, whether ported or not, and NPA-XXX and XXX-0 1XX Group Records, belonging to an NPA-XXX or XXX-0 1XX assigned to MCI.

13.3.2.3 Subsequent to the availability of a long-term solution for NP, Bell Atlantic shall enable MCI to store in Bell Atlantic's LIDB any subscriber line number or special billing number (in accordance with the technical reference in GR-1158-CORE OSSGR, Section 22.3) record, whether ported or not, regardless of the number's NPA-XXX or XXX-0 1XX.

13.3.2.4 Bell Atlantic shall perform the following LIDB functions (*i.e.*, processing of the following query types as defined in the technical reference in GR-1158-CORE OSSGR, Section 22.3) for MCI's subscriber records in LIDB:

13.3.2.4.1 Billed number screening (provides information such as whether the billed number may accept collect or third number billing calls); and

13.3.2.4.2 Calling card validation

13.3.2.5 Bell Atlantic shall process MCI's subscriber records in LIDB at least at Parity with Bell Atlantic subscriber records, with respect to other LIDB functions (as defined in the technical reference in GR-1158-CORE OSSGR, Section 22.3). Bell Atlantic shall indicate to MCI what additional functions (if any) are performed by LIDB in Bell Atlantic's network.

13.3.2.6 Within two (2) weeks after a request by MCI, Bell Atlantic shall provide MCI with a list of the subscriber data items which MCI would have to provide in order to support billed number screening and calling card validation. The list shall indicate which data items are essential to LIDB function, and which are required only to support certain services. For each data item, the list shall show the data formats, the acceptable values of the data item and the meaning of those values.

13.3.2.7 Bell Atlantic shall provide LIDB systems with rates of operating deficiencies at Parity. If, based on information available through the process set forth in Section 3, MCI believes that the rate of deficiencies is inadequate to meet its needs, it may initiate a BFR.

13.3.2.8 Bell Atlantic shall provide MCI with the capability to provision (e.g., to add, update, and delete) NPA-NXX and NXX-0 LXX group records, and line number and special billing number records, associated with MCI subscribers, directly into Bell Atlantic's LIDB provisioning process.

13.3.2.9 As directed by MCI or the new local service provider, in the event that end user subscribers change their local service provider, Bell Atlantic shall maintain subscriber data (for line numbers, card numbers, and for any other types of data maintained in LIDB), as mutually agreed by the Parties, so that such subscribers shall not experience any interruption of service, except for any interruption associated with a LIDB-only service order transaction at Parity.

13.3.2.10 All additions and updates of MCIIm data to the LIDB shall be solely at the direction of MCIIm. Bell Atlantic will process orders from other CLECs or from Bell Atlantic for subscribers that choose to migrate from MCIIm to another provider.

13.3.2.11 Bell Atlantic shall provide priority updates to LIDB for MCIIm data upon MCIIm's request (e.g., to support fraud protection) at Parity.

13.3.2.12 Bell Atlantic shall accept queries to LIDB associated with MCIIm subscriber records, and shall return responses in accordance with the requirements of this Section 13.

13.4 Toll Free Number Database

The "Toll Free Number Database" is an SCP that provides functionality necessary for toll free (e.g., 800 and 888) number services by providing routing information and additional features during call set-up in response to queries from SSPs. This Subsection 13.4 supplements the requirements of Subsection 13.2 and 13.5. Bell Atlantic shall provide the Toll Free Number Database in accordance with the following:

13.4.1 Technical Requirements

13.4.1.1 Bell Atlantic shall make the Bell Atlantic Toll Free Number Database available for MCIIm to query, from MCIIm's designated switch including Local Switching, with a toll-free number and originating information.

13.4.1.2 The Toll Free Number Database shall return carrier identification and, where applicable, the queried toll free number, translated numbers and instructions as it would in response to a query from a Bell Atlantic switch.

13.4.2 Interface Requirements

The signaling interface between the MCIIm or other local switch and the Toll Free Number Database shall use the TCAP protocol as specified in Part A, Section 15 (Technical References), together with the signaling network interface as specified in Part A, Section 15 (Technical References).

13.5 Advanced Intelligent Network ("AIN") Access, Service Creation Environment and Service Management System ("SCE/SMS") Advanced Intelligent Network Access

13.5.1 Bell Atlantic shall provide access to any and all Bell Atlantic service applications resident in Bell Atlantic's SCP. Such access may be from MCI's switch or Bell Atlantic's unbundled local switch.

13.5.2 SCE/SMS AIN access shall provide MCI the ability to create service applications in the Bell Atlantic SCE and deploy those applications via the Bell Atlantic SMS to the Bell Atlantic SCP. This interconnection arrangement shall provide MCI access to the Bell Atlantic development environment in a manner at least at Parity with Bell Atlantic's ability to deliver its own AIN-based services. SCE/SMS AIN Access is the creation and provisioning of AIN services in the Bell Atlantic network. See Figure 5 below.

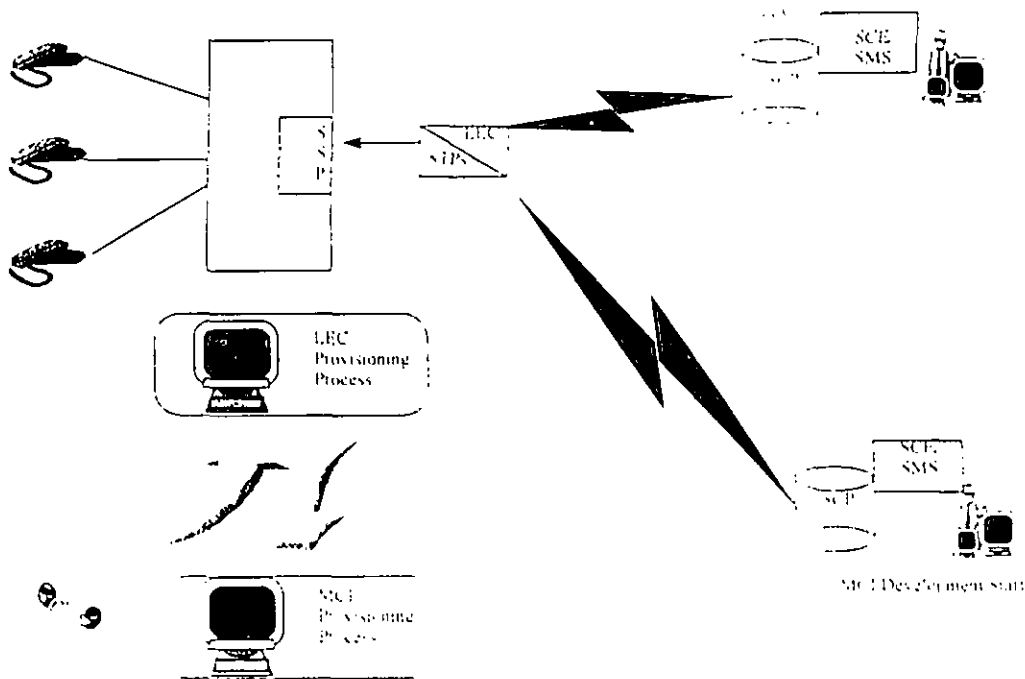

Figure 5

13.5.3 Bell Atlantic shall make SCE hardware, software, testing and technical support (e.g., help desk, system administrator) resources available to MCI. Scheduling of SCE resources shall allow MCI at least equal priority to Bell Atlantic.

13.5.4 The Bell Atlantic SCE SMS shall allow for multi-user access. Source code (i.e., AIN service applications and process flow design developed by an MCI service designer creator to provide AIN based services) management and other logical security functions will be provided.

13.5.5 Bell Atlantic shall provide reasonable protection to MCIIm service logic and data from unauthorized access, execution or other types of compromise.

13.5.6 Bell Atlantic or a designated vendor shall provide for service creation training, documentation, and technical support of MCIIm development staff at Parity with that provided to Bell Atlantic's own development staff. Training sessions shall be "suiteased" to MCIIm facilities or delivered at Bell Atlantic facilities at MCIIm's cost, at MCIIm's discretion, subject to vendor's requirements.

13.5.7 When MCIIm selects SCE SMS AIN access, Bell Atlantic shall provide for a secure, controlled access environment on-site as well as via remote data connections (*i.e.*, ISDN circuit switched data).

13.5.8 When MCIIm selects SCE SMS AIN access, Bell Atlantic shall allow MCIIm to transfer data forms and/or tables to the Bell Atlantic SCP via the Bell Atlantic SMS (*e.g.*, service customization and subscriber subscription) in a manner consistent with how Bell Atlantic provides that capability to itself.

13.5.9 When MCIIm selects SCE SMS AIN access for providing services on MCIIm's network, the Parties will work cooperatively to resolve technical and provisioning issues.

Section 14. Tandem Switching

14.1 Definition:

14.1.1 Tandem Switching includes trunk-connect facilities, the basic switching function of connecting trunks to trunks, and the functions that are centralized in tandem switches. Tandem Switching creates a temporary transmission path between interoffice trunks that are interconnected at a Bell Atlantic access tandem switch for the purpose of routing a call or calls.

14.2 Technical Requirements

14.2.1 Tandem Switching shall provide:

14.2.1.1 Signaling to establish a tandem connection;

14.2.1.2 Screening and routing at Parity;

14.2.1.3 To the extent Technically Feasible and at Parity, Tandem Switching shall provide recording of billable events;

14.2.1.4 Tandem Switching shall provide AIN triggers supporting AIN features at Parity with its provision of such triggers for Bell Atlantic subscribers:

14.2.1.5 Bell Atlantic's Tandem Switching shall provide access to toll free and Number Portability databases in the same manner as it provides such access to itself and its Bell Atlantic subscribers:

14.2.1.6 Tandem Switching shall provide all trunk interconnections, where available, in Bell Atlantic's access tandems; and

14.2.1.7 Tandem Switching shall accept connections (including the necessary signaling and trunking interconnections) between end offices, IXCs, ITCs, CAPs and CLEC switches that subtend interconnect at the same tandem.

14.2.2 Tandem Switching shall provide local tandeming functionality between two End Offices that subtend interconnect at the same tandem, including two offices belonging to different CLECs (e.g., between an MCIIm end office and the end office of another CLEC).

14.2.3 Tandem Switching shall preserve CLASS LASS features and Caller ID as traffic is processed on SS7 trunk groups at Parity. Additional signaling information and requirements are provided in Section 12.

14.2.4 Bell Atlantic shall perform routine testing and fault isolation on the underlying switch that is providing Tandem Switching and all its interconnections at Parity with its performance of such testing for its own subscriber services. When commonly available, the results of the testing shall be made immediately available to MCIIm.

14.2.5 Tandem Switching shall control congestion using capabilities such as automatic congestion control and network routing overflow. Congestion control provided or imposed on MCIIm traffic shall be at Parity with controls being provided or imposed on Bell Atlantic traffic for itself and its subscribers.

14.2.6 Tandem Switching shall route calls to Bell Atlantic or MCIIm endpoints or platforms for which Tandem Switching is provided. For Tandem Switching with unbundled Common Transport, call routing including overflow is accomplished as Bell Atlantic's network normally routes the calls. For Tandem Switching with unbundled Dedicated Transport, specific routing may be requested through the BFR process.

14.2.7 Tandem Switching shall process originating toll-free traffic received from an MCIIm local switch.

14.2.8 In support of AIN triggers and features, Tandem Switching shall provide SSP capabilities at Parity with Bell Atlantic's provision of these capabilities for its own subscribers under the same circumstances when these capabilities are not available from Local Switching.

14.2.9 The Local Switching and Tandem Switching functions may be combined in an office. If this is done, both Local Switching and Tandem Switching shall provide all of the functionality required of each of those Network Elements in this Agreement.

14.3 Interface Requirements

14.3.1 Tandem Switching shall interconnect, with direct trunks, to all carriers with which Bell Atlantic interconnects.

14.3.1.1 Transit traffic that is originated by an LEC or wireless carrier shall be settled in accordance with the terms of an appropriate IntraLATA Telecommunications Services Settlement Agreement between the Parties substantially in the form appended hereto as Exhibit H. Meet-Point Billing compensation arrangements as described in Section 3 of Attachment VIII shall be utilized for compensation for the joint handling of toll traffic.

14.3.1.2 Bell Atlantic expects that most networks involved in transit traffic will deliver each call to each involved network with CCS and the appropriate TCAP message to facilitate full interoperability of those services supported by Bell Atlantic and billing functions. In all cases, each Party shall follow the Exchange Message Record ("EMR") standard and exchange records between the Parties and with the terminating carrier to facilitate the billing process to the originating network.

14.3.1.3 Transit traffic to and from MCIIm shall be routed over the traffic exchange trunks.

14.3.2 Bell Atlantic shall provide signaling necessary to provide Tandem Switching with feature functionality impacts and effects at Parity.

Section 15. Additional Requirements

This Section 15 of Attachment III sets forth the additional requirements for Network Elements which Bell Atlantic agrees to offer to MCIIm under this Agreement.

15.1 Cooperative Testing

15.1.1 Definition:

"Cooperative Testing" means that both Bell Atlantic and MCI shall cooperate with reasonable requests from the other to (i) ensure that the Network Elements and ancillary functions and additional requirements being provided to MCI by Bell Atlantic are in compliance with the requirements of this Agreement, (ii) test the overall functionality of various Network Elements and ancillary functions provided by Bell Atlantic to MCI in combination with each other or in combination with other equipment and facilities provided by MCI or third-parties, (iii) test the overall functionality of services provided by third-parties involving or combining Network Elements provided by Bell Atlantic and services provided by MCI, and (iv) ensure that billing data can be provided to MCI and Bell Atlantic.

15.1.2 Requirements

Within forty-five (45) days after the Effective Date of this Agreement, MCI and Bell Atlantic will agree upon a process to resolve technical issues relating to interconnection of MCI's network to Bell Atlantic's network and Network Elements and ancillary functions. The agreed upon process shall include procedures for escalating disputes and unresolved issues up through higher levels of each Party's management. If MCI and Bell Atlantic do not reach agreement on such a process within forty-five (45) days, any issues that have not been resolved by the Parties with respect to such process shall be submitted to the procedures set forth in Part A, Section 24 (Dispute Resolution Procedures) of this Agreement unless both Parties agree to extend the time to reach agreement on such issues.

15.1.2.1 Where mutually agreed (e.g., POI) days in the common area associated with physical Collocation), Bell Atlantic shall provide MCI access for testing MCI facilities at interfaces between a Bell Atlantic Network Element, or at interfaces between a Bell Atlantic Combination, and MCI equipment or facilities. This access shall be available seven (7) days per week, twenty-four (24) hours per day.

15.1.2.2 When mutually agreed, Bell Atlantic shall temporarily provision MCI designated Local Switching features (e.g., customized routing) for testing. MCI and Bell Atlantic shall mutually agree on the procedures to be established between Bell Atlantic and MCI to expedite such provisioning processes for feature testing.

15.1.2.3 Upon reasonable request, Bell Atlantic and MCI shall provide technical staff to meet with each other to provide required support for Cooperative Testing.

15.1.2.4 Dedicated Transport and ULL may experience alarm conditions due to in-progress tests. When an entire Bell Atlantic facility is dedicated to MCI services, Bell Atlantic shall not remove such facility from service without obtaining MCI's prior approval.

15.1.2.5 Bell Atlantic shall provide to MCI electronic access to 105 type responders, 100-type test lines, or 102-type test lines associated with any circuits under test.

15.1.2.6 MCI and Bell Atlantic shall endeavor to complete Cooperative Testing as stated in Attachment VIII.

15.1.2.7 MCI may accept or reject the Network Element ordered by MCI if, upon completion of cooperative acceptance testing, the tested Network Element does not meet the requirements stated in applicable technical references included in Appendix 15 (Technical Reference Schedule) of Part A.

15.2 Protection, Restoration, and Disaster Recovery

15.2.1 Scope

This Section refers specifically to requirements on the use of redundant network equipment and facilities for protection, restoration, and disaster recovery.

15.2.2 Requirements

15.2.2.1 Bell Atlantic shall provide protection, restoration, and disaster recovery capabilities at Parity with those capabilities provided for their own services, facilities and equipment (e.g., equivalent circuit pack protection ratios, facility protection ratios).

15.2.2.2 Bell Atlantic shall provide Network Elements equal priority in protection, restoration, and disaster recovery as provided to their own services, facilities and equipment.

15.2.2.3 Bell Atlantic shall provide Network Elements equal priority in the use of spare equipment and facilities as provided to their own services, facilities and equipment.

15.2.2.4 Bell Atlantic shall restore Network Elements which are specific to MCI end user subscribers on a priority basis as MCI may designate at Parity.

15.3 Synchronization

15.3.1 Definition:

"Synchronization" is the function which keeps all digital equipment in a communications network operating at the same average frequency. With respect to digital transmission, information is coded into discrete pulses. When these pulses are transmitted through a digital communications network, all synchronous Network Elements are traceable to a stable and accurate timing source. Network synchronization is accomplished by timing all synchronous Network Elements in the network to a stratum 1 source so that transmission from these network points have the same average line rate.

15.3.2 Technical Requirements

The following requirements are applicable to the case where Bell Atlantic provides synchronization services to equipment that MCI owns and operates within a Bell Atlantic location. In addition, these requirements apply to all synchronous equipment that is owned by Bell Atlantic and is used to provide a Network Element to MCI. Synchronization services by Bell Atlantic shall be subject to rates and charges to be determined.

15.3.2.1 The synchronization of clocks within digital networks is divided into two parts: intra-building and inter-building. Within a building, a single clock is designated as the building integrated timing supply ("BITS"), which provides all of the DS1 and DS0 synchronization references required by other clocks in such building. This is referred to as intra-building synchronization. The BITS receives synchronization references from remotely located BITS. Synchronization of BITS between buildings is referred to as inter-building synchronization.

15.3.2.2 To implement a network synchronization plan, clocks within digital networks are divided into four stratum levels. All clocks in strata 2, 3, and 4 are synchronized to a stratum 1 clock, that is, they are traceable to a stratum 1 clock. A traceable reference is a reference that can be traced back through some number of clocks to a stratum 1 source. Clocks in different strata are distinguished by their free running accuracy or by their stability during trouble conditions such as the loss of all synchronization references.

15.3.2.2.1 Intra-Building

15.3.2.2.1.1 Within a building, there may be different kinds of equipment that require synchronization at the DS1 and DS0 rates. Synchronization at the DS1 rate is accomplished by the frequency synchronizing presence of buffer stores at various DS1 transmission interfaces. Synchronization at the DS0 rate is accomplished by using a composite clock signal that phase synchronizes the clocks. Equipment requiring DS0 synchronization frequently does not have adequate buffer storage to accommodate the phase variations among different equipment. Control of phase variations to an acceptable level is accomplished by externally timing all interconnecting DS0 circuits to a single clock source and by limiting the interconnection of DS0 equipment to less than 1,500 cable feet. Therefore, a BITS shall provide DS1 and composite clock signals when the appropriate composite signal is a 64-kHz 5/8th duty cycle, return to zero with a bipolar violation every eighth pulse ("B8RZ").

15.3.2.2.2 Inter-Building

15.3.2.2.2.1 Bell Atlantic shall provide inter-building synchronization at the DS1 rate, and the BITS shall accept the primary and secondary synchronization links from BITS in other buildings. From hierarchical considerations, the BITS shall be the highest stratum clock within the building and Bell Atlantic shall provide operations capabilities (this includes, but is not limited to: synchronization reference provisioning; synchronization reference status inquiries; timing mode status inquiries; and alarm conditions).

15.3.3 Synchronization Distribution Requirements

15.3.3.1 Central Office BITS shall contain redundant clocks meeting or exceeding the requirements for a stratum 3 enhanced clock as specified in ANSI T1.101-1994 and Bellcore *GR-1244 Clocks for the Synchronized Network: Common Generic Criteria*.

15.3.3.2 Central Office BITS shall be powered by primary and backup power sources.

15.3.3.3 If both reference inputs to the BITS are interrupted or in a degraded mode (meaning off frequency greater than twice the minimum accuracy of the BITS, loss of frame, excessive bit errors, or in alarm indication signal), then the stratum clock in the BITS shall provide the necessary bridge in timing to allow the network to operate without a frame repetition or deletion (slip free) with better performance than 1 frame repetition or deletion (slip) per week.

15.3.3.4 DSIs multiplexed into a SONET synchronous payload envelope within an STS-n (where n is defined in ANSI T1.105-1995) signal shall not be used as reference facilities for network synchronization.

15.3.3.5 The total number of Network Elements cascaded from the stratum 1 source shall be minimized.

15.3.3.6 A Network Element shall receive the synchronization reference signal only from another Network Element that contains a clock of equivalent or superior quality (stratum level).

15.3.3.7 Bell Atlantic shall select for synchronization those facilities shown to have the greatest degree of availability (absence of outages).

15.3.3.8 Where possible, all primary and secondary synchronization facilities shall be physically diverse (this means the maximum feasible physical separation of synchronization equipment and cabling).

15.3.3.9 No timing loops shall be formed in any combination of primary and secondary facilities.

15.3.3.10 An operations support system (OSS) shall continuously monitor the BITS for synchronization related failures or degradation.

15.3.3.11 An OSS shall continuously monitor all equipment transporting synchronization facilities for synchronization related failures or degradation.

15.3.3.12 For non-SONET equipment, Bell Atlantic shall provide synchronization facilities which, at a minimum, comply with the standards set forth in ANSI T1.101-1994.

15.3.3.13 All equipment approved for deployment in Bell Atlantic's network shall meet Bellcore GR-253 and GR-1244 requirements.

Section 16. Basic 911 and E911

See Attachment VIII, Section 6.1.1.

Section 17. Directory Assistance Data

See Attachment VIII, Section 6.1.6. and Section 6.2.

EXHIBIT A

EXHIBIT A

TR 72565
Issue 2, December 1996

Bell Atlantic Technical Reference

**Basic Unbundled Loop Services
Technical Specifications**

© 1996 Bell Atlantic Network Services, Inc.
All Rights Reserved
Printed in U.S.A.

Bell Atlantic Network Services, Inc.
Technical Reference

TR-72565
Issue 2, December 1996

Notice

This Technical Reference is published by Bell Atlantic to provide a technical description of Basic Unbundled Loop Services. To the extent feasible, the description references or duplicates existing published technical references utilized by the industry.

Bell Atlantic reserves the right to revise this technical reference for any reason including, but not limited to, changes in tariffs, laws, or regulations, conformity with updates and changes in standards promulgated by various agencies, utilization of advances in the state of technical arts, or the reflection of changes in the design of any facilities, equipment, techniques, or procedures described or referred to herein. Liability for difficulties arising from technical limitations or changes herein is disclaimed.

Bell Atlantic reserves the right not to offer any or all of these services and to withdraw any or all of them at any future time. In addition, the services described herein are based on available facilities and equipment and may not be universally available.

With respect to services offered pursuant to tariff, however, the terms and conditions of the service offering are determined by the tariff itself and applicable laws and regulations. This reference is intended to be supplemental to the tariffs. In the event of a conflict between the tariffs, laws or regulations and this reference, the tariffs, laws, and regulations shall govern.

For additional copies, please contact:

Bell Atlantic Document and Information Delivery Services
1310 N. Court House Road
Arlington, VA 22201
703-974-5887

For information about the technical specifications in this TR, contact

Trone Bishop
1 East Pratt St.
Baltimore, Md. 21202
410-736-7622

EXHIBIT A

Bell Atlantic Network Services, Inc.
Technical Reference

TR 72565
Issue 2, December 1996

Bell Atlantic
Basic Unbundled Loop Services
Technical Specifications

| Contents | Page |
|--|-------------|
| 1. General | 1 |
| 2. Service Description | 1 |
| A. General | 1 |
| B. Physical Characteristics | 1 |
| C. Service Elements | 2 |
| D. Compatibility Considerations | 3 |
| 3. Element Specifications | 3 |
| A. General | 3 |
| B. CODF Wiring and Tie Cable(s) | 3 |
| C. Subscriber Loop Facilities | 4 |
| D. Transmission and Signaling (T&S) | |
| Enhancement Equipment | 6 |
| 4. Service Specifications | 6 |
| 5. OTC Equipment and CO Cabling Requirements | 7 |
| A. OTC Equipment Requirements | 7 |
| B. OTC Equipment CO Cabling Requirements | 8 |
| 6. References | 9 |
| A. Definitions | 9 |
| B. Acronyms | 11 |
| 7. Bibliography | 12 |
| 8. Appendix A: Historical Loop Design Rules | 14 |

| Figures | Page |
|--|-------------|
| Figure 2-1: Typical BULS configuration | 2 |
| Figure 4-1: Compatible BULS NCI Code Combinations | 6 |
| Figure 4-2: BULS Acceptance Limits (AL) and Immediate Action Limits (IAL) | 7 |

1. General

1.01 This document provides the technical specifications for the Basic Unbundled Loop Services (BULS) offered by Bell Atlantic in the co-carrier section of local exchange tariffs.

1.02 This technical reference has been reissued to provide a revised leakage specification and to provide interface code information. In addition, several editorial changes have been made.

1.03 BULS enable Other Telephone Companies (OTC) collocated in a Bell Atlantic (BA) Central Office (CO) to connect to analog subscriber loops to provide loop-start switched access services to end-user locations.

1.04 The technical specifications in this document assume that the OTC is collocated in the same CO as the BULS loop. In the future, Bell Atlantic may offer transport services for analog unbundled loops, however such transport will not be available for BULS. In instances where an OTC desires transport for a loop-start analog unbundled loop, the OTC must order Analog Unbundled Loop Service with Customer Specified Signaling (AULSCSS) and specify loop-start signaling. The technical specifications for AULSCSS may be found in BA TR72570.

2. Service Description

A. General

2.01 The description, terms and conditions, rates, regulations, and Universal Service Order Codes (USOCs) for Basic Unbundled Loop Services are contained in applicable tariffs or contracts.

2.02 Basic Unbundled Loop Services (BULS) provide the customer with a voice grade transmission channel suitable for loop-start signaling and the transport of analog voice grade signals. The channel is between the Central Office Distributing Frame (CODF) termination of OTC equipment in a BA Central Office (CO) and the Rate Demarcation Point (RDP) at an end-user customer location.

2.03 BULS is provided subject to availability on a first-come first-served basis. Special construction charges apply when appropriate facilities are not available.

B. Physical Characteristics

2.04 The interface at the CODF termination is 2-wire and the interface at the RDP is 2-wire. At each interface one conductor is called tip and the other conductor is called ring. A typical BULS configuration is shown in Figure 2-1.

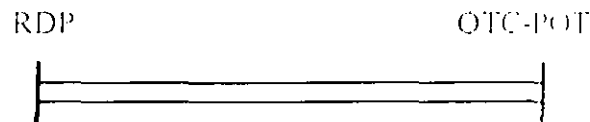

Figure 2-1: Typical BULS configuration

2.05 The transmission channel between the BULS 2-wire interfaces is effective 2-wire. An effective 2-wire channel may be entirely 2-wire or it may contain a 4-wire facility portion (such as a Digital Loop Carrier) with a 2-wire metallic extension to the end-user's RDP. The transmission channel is suitable for the transport of analog voice grade signals between approximately 300 and 3000 Hz.

2.06 BULS may be provided using a variety of loop transmission technologies, including but not limited to, metallic cable, metallic cable based digital loop carrier, and fiber optic digital loop carrier systems.

2.07 When digital loop carrier (DLC) is used to provide BULS, the DLC will provide loop-start signaling at the RDP that meets the network requirements in ANSI T1.401-1993 [1].

C. Service Elements

2.08 BULS ordinarily consists of two elements:

(1) the CODF wire and tie cable(s) between the CODF termination of the collocated OTC equipment and the CODF termination of a subscriber loop; and,

(2) a subscriber loop facility between the CODF and the end-user customer's RDP. The loop is either:

(a) a metallic facility consisting of cable and wire between the CODF and the RDP; or,

(b) a universal DLC channel with loop start (LS) signaling capability. The DLC channel consists of:

- CO cabling between the CODF and a DLC Central Office Terminal (COT) equipped with a LS open-end channel unit;

- a fiber or metallic facility from the DLC COT to the DLC Remote Terminal (RT) equipped with a LS closed-end channel unit; and,

- cable and wire between the DLC RT and the RDP.

D. Compatibility Considerations

2.09 BULS utilizes subscriber loop facilities that have been designed for Plain Ordinary (analog) Telephone Service (POTS). In most cases, BULS should be suitable for loop-start single line residential service and loop-start single line business service. POTS qualified loops may not be suitable for data or other special services however.

2.10 Bell Atlantic does not guarantee that BULS will be suitable for analog data (e.g., V.32, V.32bis, V.34, etc.). If a customer is able to send and receive data, Bell Atlantic will not guarantee a data rate.

2.11 Special services such as Centrex, Foreign Exchange, Secretariat, and Wide Area Telephone Service lines may have service requirements that are more stringent than POTS. If such services are provided using BULS and electronic transmission and signaling enhancement equipment is required to meet the more stringent requirements, the OTC will be responsible for providing such enhancement equipment.

2.12 Bell Atlantic will work with the OTC to resolve facility problems should the BULS loop facility require enhancement equipment to support loop-start POTS voice service.

3. Element Specifications

A. General

3.01 Two elements are always used with Basic Unbundled Loop Services. They are: CODF wire and tie cable(s), and subscriber loop facilities. A third element, electronic transmission and signaling enhancement equipment, is sometimes used with BULS. The following sections contain the specifications for each of these elements.

B. CODF Wiring and Tie Cable(s)

3.02 CODF cross-connect wiring and tie cable(s) are used to link the CODF termination of co-located OTC equipment to the CODF termination of metallic subscriber loops, DLC COFs, and electronic transmission and signaling enhancement equipment.

3.03 The total combined length of all CODF cross-connect wiring and all CODF-to-CODF tie cables between the CODF termination of the OTC equipment and the CODF termination of any subscriber loop in the same CO should be less than 1500 feet.

3.04 The direct-current resistance between the CODF termination of the OTC equipment and the CODF termination of any subscriber loop in the same CO should be less than 80 ohms. This is equal to 1500 or less feet of 24 gauge cable.

3.05 The 1kHz loss measured on the CODF wiring and tie cables when measured between 900 ohm impedances should be .5 dB or less.

3.06 The C-message noise measured on the CODF wiring and tie cables shall be 20 dBmC or less.

C. Subscriber Loop Facilities

3.07 Subscriber loop facilities consist of feeder and distribution plant between the CODF and the end-user customer's RDP. Feeder plant uses a variety of transmission technologies, including but not limited to, twisted-pair metallic cables, twisted-pair metallic cable based digital loop carrier, and fiber optic based digital loop carrier. Distribution plant usually consists of multipair metallic cables. Additional information about subscriber loops may be found in Bellecore SR-TSV-002275 [2] and appendix A of this document.

3.08 A twisted-pair metallic loop facility consists entirely of metallic cable and wire between the CODF and the end-user customer's RDP. Most metallic loops consist of multipair cables, laid out on aerial, underground, or buried routes to suit the needs of a particular community. The metallic loop facility may be loaded or non-loaded. It may also have bridged-tap. Loaded bridged-tap and bridged tap between load coils are not permitted.

3.09 A universal DLC facility consists of CO cabling between the CODF and a DLC COT, QSP fiber or metallic cable facilities from the DLC COT to the DLC RT, and cable and wire between the DLC RT and the end-user customer's RDP. Some DLC may not support enhanced services such as distinctive ringing, forward disconnect, caller ID, etc.

3.10 Subscriber loop facilities have been designed on a global basis primarily to accommodate POTS and guarantee that loop transmission loss is statistically distributed and that no single loop exceeds the signaling range of the CO.

3.11 Prior to 1980, loops were designed using one of the following design plans: Resistance Design (RD), Long Route Design (LRD), or Unigauge Design (UD). From 1980 to 1986, the Modified Resistance Design (MRD), Modified Long Route Design (MLRD), and Concentrated Range Extension with Gain (CREG) plans were applied on a going-forward basis (i.e., retroactive redesign was not implemented). In 1986, the Revised Resistance Design (RRD) plan was applied on a going-forward basis. Appendix A provides a summary of the various loop design plans.

3.12 Most metallic loop facilities (98%) were designed using the RD, MRD, or RRD design rules. The RRD design rules currently in use limit the loop resistance to the design range of the CO switch (1300 or 1500 ohms) or 1500 ohms whichever is less. The 1kHz loss of RRD loops is 8.5 dB or less.

3.13 A small number of loops have been designed using the LRD, MLRD, UD, and CREG design plans. These loops are long (15-kft) and have high resistance (up to 2800 or 3600 ohms) and high loss (up to 13 dB without gain). Such loops require electronic transmission and signaling range enhancement equipment to accommodate POTS. The LRD and MLRD design plans use Range

Extension with Gain (REG) equipment that is either dedicated to each loop or hard-wired to the BA CO line equipment. In the latter case, the hard-wired REG is not available for use with BULS.

3.14 The REG equipment used with CREG designed loops is implemented behind a stage of switching concentration in the associated CO switch. This permits REG equipment to be shared with other loops working out of the same CO switch. For this reason, the REG associated with CREG designed loops is not available for use with BULS. Bell Atlantic will work with the OTC to explore available options when an LRD, MLRD, or CREG designed loop requires enhancement to support BULS.

3.15 The direct-current resistance of a metallic loop facility measured between the CODB and the RDP shall be 1520 ohms or less if the facility was designed using RRD, MRD, or LRD rules. The resistance will be 2500 ohms or less if the facility was designed using UD rules, 2800 ohms or less if the facility was designed using CREG or MLRD rules, and 3600 ohms or less if the facility was designed using LRD rules.

3.16 The 1kHz loss of a metallic loop facility when measured with a 900 ohm impedance at the CODB and a 600 ohm impedance at the RDP shall be 8.5 dB or less if the loop was designed using RRD, MRD, or LRD rules. The loss will be 10 dB or less if the loop was designed using UD or CREG rules, and 13 dB or less if the loop was designed using MLRD rules.

3.17 The C-message noise measured on a metallic subscriber loop at the RDP shall be less than 30 dBmC.

3.18 The leakage resistance between the tip conductor and ground and the ring conductor and ground shall each be greater than 100 K ohms.

3.19 The longitudinal noise or power influence (PI) measured per IEEE Std 743-1984 [3] on the metallic portion of a loop should be less than 90 dBmC.

3.20 The longitudinal balance of a metallic subscriber loop is defined as the longitudinal noise (in dBmC) minus the C-message noise (in dBmC). The longitudinal balance shall be ≥ 50 dB.

3.21 DLC facilities shall provide a battery feed to the RDP. When the RDP is terminated by a direct-current resistance of 430 ohms or less, the loop current shall be ≥ 10 mA or greater.

3.22 The 1kHz loss of a DLC facility when measured with a 900 ohm impedance at the CODB and a 600 ohm impedance at the RDP shall be 8 dB or less.

3.23 The C-message noise measured on a DLC facility shall be 23 dBmC or less.

3.24 The C-Notched noise measured on a DLC facility shall be 36 dBmC or less with a -13 dBm0 1004 Hz holding tone.

3.25 The impulse noise measured on a DLC facility shall be no more than 15 counts in 15 minutes with a threshold of 59 dBmC.

3.26 Subscriber loop facilities shall meet all applicable design specifications. (See appendix A)

3.27 The echo return loss and singing return loss of a subscriber loop facility measured with a 900 ohm + 2.16 uf reference at the CODF and a 600 ohm + 2.16 uf termination at the RDP shall be equal to or greater than 5.5 dB and 2.5 dB respectively.

D. Transmission and Signaling (T&S) Enhancement Equipment

3.28 Transmission and signaling (T&S) enhancement equipment is sometimes used with BULS. Several different types of T&S equipment can be used. Examples are: transmission repeaters; loop signaling repeaters; and signaling battery boost equipment.

3.29 T&S equipment is often used with BULS loops designed to LRD, MLRD, UD, and CREG rules. Such devices are often called Range Extenders with Gain (REGs).

3.30 The impedance of T&S equipment shall be a nominal 900 ohms when used in the CO and a nominal 600 ohms when used at or near the RDP.

3.31 T&S equipment shall provide 20 mA or more of loop current when the RDP is terminated by a direct-current resistance of 430 ohms or less.

3.32 The C-message noise measured on T&S equipment shall be 20 dBmC or less.

3.33 The C-Notched noise measured on T&S equipment shall be 36 dBmC or less with a -13 dBm0 1004 Hz holding tone.

4. Service Specifications

4.01 The overall end-to-end BULS service is from the CODF termination of the OTC equipment to the end-user customer's RDP. The compatible BULS Network Channel Interface (NCI) code combination is shown in Figure 4-1.

Figure 4-1: Compatible BULS NCI Code Combinations

| EU-POT | OTC-POT |
|--------|-----------|
| 02LS2 | 02QC3.OOD |

4.02 Parameters are tested at the RDP in response to trouble reports or when additional testing is purchased.

4.03 Acceptance Limits (AL) and Immediate Action Limits (IAL) are shown in Figure 4-2 for loops designed to RD, MRD, and RRD rules. The resistance and loss parameters of loops designed to LRD, MLRD, UD, and CREG rules are in Appendix A.

Figure 4-2: BULS Acceptance Limits (AL) and Immediate Action Limits (IAL)

| PARAMETER | AL | IAL |
|-------------------------|---------------|---------------|
| 1004 Hz Loss | < 8.5 dB | > 10.0 dB |
| Resistance | < 1520 ohms | > 1520 ohms |
| Leakage | > 100 kilohms | < 100 kilohms |
| C-Message Noise | < 30 dBmC | > 30 dBmC |
| Power Influence | < 90 dB | > 90 dB |
| Loop Current (DLC only) | > 20 mA | < 20 mA |

5. OTC Equipment and CO Cabling Requirements

A. OTC Equipment Requirements

5.01 Co-located OTC equipment used for interconnection with BULS shall meet all of the applicable generic equipment requirements in Bellecore GR-63-CORE [4] and Bellecore GR-1089-CORE [5].

5.02 Co-located OTC equipment used for interconnection with BULS shall be manufactured in accordance with FCC, NEC, UL, and USDL requirements and orders applicable to Federal, State, and local requirements including, but not limited to, statutes, rules, regulations, orders, or ordinances, or otherwise imposed by law. Requirements that are not specified in this document, contractual technical requirements, or other applicable documents, shall meet the manufacturer's requirements consistent with industry standards.

5.03 The open circuit tip-to-ring dc voltage that collocated OTC equipment applies to BA VF cabling shall be less than 80 Vdc.

5.04 Co-located OTC equipment shall not deliver more than 2.5 watts of power to any load via BA VF cable.

5.05 Co-located OTC equipment shall not deliver more than 150 mA of loop current to any load via BA VF cable.

5.06 The noise limits for BULS require collocated OTC equipment to have a longitudinal balance of >60 dB.

5.07 The loss and noise limits for BULS require collocated OTC equipment to have a nominal impedance of 900 ohms.

5.08 The applied power level of any transmitted signal on BULS averaged over 3 seconds shall not exceed -13 dBm0.

5.09 Loops may be exposed to electrical surges from lightning and commercial power system disturbances. Despite protective devices on the CODF, some of these disturbances are likely to reach OTC equipment. OTC equipment shall be designed to withstand certain surges without being damaged, and shall fail in a safe manner under infrequent high stress.

5.10 The prevalent voltage-limiting device available for CO use is the 3-mil carbon block. This device has an upper 3 σ limiting voltage of 1000 volts peak under surge conditions and 600 volts rms (800 peak) at 60 Hz. OTC equipment connected to BULS loops protected by carbon blocks may be subjected to voltages up to these levels. Unexposed COs may not have primary protection, and OTC equipment not coordinating with carbon blocks may need protection in these locations.

5.11 If the subscriber loop facility is exposed to commercial ac power, the CO protector may also include 350 mA heat coils for limiting the current that is permitted to flow to CO equipment. In addition, a protective fuse cable located outside the CO incorporating 24 or 26 AWG conductors to coordinate with the protector, serves to limit current to safe levels in the event of prolonged operation of the protector during power fault conditions.

B. OTC Equipment CO Cabling Requirements

5.12 The voice grade CO cabling used to terminate OTC equipment on the CODF shall use twisted-pair conductors.

5.13 The type, gauge, and length of the OTC CODF cabling shall be specified based on this specification and OTC equipment requirements. If the specifications in this document differ from the OTC equipment manufacturers specifications, then the more stringent of the two shall be used.

5.14 The direct-current resistance of the CO cabling between the OTC equipment and the CODF shall meet the CO cabling requirements in the Bellecore FR-TSY-0000416 (i.e., 23 ohms or less). This is equivalent to 275 feet or less of 26 gauge cable, 440 feet or less of 24 gauge cable, and 700 feet or less of 22 gauge cable.

5.15 All CO cabling between OTC equipment and the CODF shall be equipped with connectors at each end. The type of connectors shall be specified by the BA CO Engineer.

5.16 The 1kHz loss of the CO cabling between the OTC equipment and the CODF, when measured between 900 ohm impedances, shall be less than .15 dB.

5.17 The C-message noise measured on the CO cabling between the OTC equipment and the CODF shall be 20 dBmC or less.

6. References

A. Definitions

Basic Unbundled Loop Services (BULS)

A basic unbundled loop service is a service that provides a basic untreated or unconditioned loop-start channel between the Bell Atlantic central office distributing frame termination of collocated equipment belonging to an OTC and the rate demarcation point at a customer location.

Battery Boost

A series aiding battery source that extends the signaling range of current sensing equipment.

Bridged tap

Any branch section of a cable pair, or any extension of a cable pair beyond the point where it is used, in which no direct current flows when customer equipment is connected and used.

Central Office (CO)

A telephone company building which houses equipment and facilities used to provide switched access services.

Central Office Distributing Frame (CODF)

Framework located in a CO that holds wire cross-connects which are used to interconnect cable terminations for end-user customer loops, switching system ports, and inter-office facilities.

C-Message Noise

The frequency-weighted, short-term average noise within an idle channel. The frequency weighting, called C-message, is used to account for the variations in 500-type telephone set transducer efficiency and end-user annoyance to tones as a function of frequency.

C-Notched Noise

The C-message frequency-weighted noise on a channel with a holding tone that is removed at the measuring end through a notch (very narrow band) filter.

Channel

An electrical, or photonic communications path between two or more points of transmission.

Closed End

The end of a switched access service that receives ringing and dial tone and transmits address signals.

dBm

A unit for expression of power level in decibels relative to one milliwatt.

dBm0

Power level referred to, or measured at, a zero transmission level point (OTLP).

dBrn

A unit used to express noise power relative to one picowatt (-90 dBm).

dBrnC

Noise power measured with C-message weighting expressed in dBm.

dBrnC0

Noise power in dBrnC referred to, or measured at, a zero transmission level point (OTLP).

Decibel (dB)

The logarithmic unit of signal power ratio most commonly used in telephony. It is used to express the relationship between two signal powers, usually between two acoustical, electric, or optical signals; it is equal to ten times the common logarithm of the ratio of the two signal powers.

Facilities

Any cable, poles, conduit, microwave, or carrier equipment, central office distributing frames, central office switching equipment, computers (both hardware and software), business machines, etc., utilized to provide the services offered by a telephone company.

Impulse Noise

Any momentary occurrence of noise on a channel that significantly exceeds the normal noise peaks. Impulse noise is analyzed by counting the number of occurrences that exceed a threshold.

Leakage

The resistance between the conductors of an insulated metallic pair or the resistance between each conductor of an insulated metallic pair and ground.

Loop

A transmission channel between a end-user customer location and a BAXCO that is used as a transmission channel for telephone company services.

Loop-start (LS) Signaling

A type of switched access line signaling in which the network provides a battery source. To initiate a call, customer premises equipment will provide a loop closure that causes dc loop current to flow which the network will detect.

Open End

The end of a switched access service that transmits ringing and dial tone and receives address signaling.

Other Telephone Company (OTC)

An organization that provides telecommunications services to the public.

Plain Ordinary Telephone Service (POTS)

The basic single line switched access service offered by local exchange carriers to residential and business customers. POTS uses loop-start signaling.

Power Influence (PI)

The power of a longitudinal signal induced in a metallic loop by an electromagnetic field emanating from a conductor or conductors of a power system. PI is also called longitudinal noise or noise-to-ground.

Rate Demarcation Point (RDP)

The point at which Bell Atlantic network access recurring charges and responsibility stop and beyond which customer responsibility begins. The RDP is the point of demarcation and/or interconnection between a Bell Atlantic subscriber loop facility and end-user premises cabling or terminal equipment. Bell Atlantic facilities at, or constituting, the rate demarcation point shall consist of wire or a jack conforming to Subpart F of Part 68 of FCC rules.

Signaling Repeater

Loop enhancement equipment that detects and regenerates signaling states.

Transmission Repeater

Loop enhancement equipment that amplifies and equalizes voice frequency signals.

Unbundled Business Loop Service

The product name for a basic unbundled loop service offered in BA-MD.

Unbundled Loop

A transmission channel between a end-user customer location and a LEC CO that is not a part of, or connected to, other LEC services.

Voice Grade (VG)

A term used to describe a channel, circuit, facility, or service that is suitable for the transmission of speech, digital or analog data, or facsimile, generally with a frequency range of about 300 to 3000 Hz.

B. Acronyms

| | |
|------|--|
| ANSI | American National Standards Institute |
| BA | Bell Atlantic |
| BULS | Basic Unbundled Loop Service |
| CO | Central Office |
| CODF | Central Office Distributing Frame |
| COT | Central Office Terminal |
| CREG | Concentrated Range Extension with Gain |
| DLC | Digital Loop Carrier |
| EU | End User |

| | |
|---------|---|
| EU-POT | End User Point Of Termination |
| FCC | Federal Communications Commission |
| IEEE | International Electrical and Electronic Engineers |
| LRD | Long Route Design |
| LS | Loop-Start |
| MLRD | Modified Long Route Design |
| MRD | Modified Resistance Design |
| NEC | National Electric Code |
| OTC | Other Telephone Company |
| OTC-POT | Other Telephone Company Point Of Termination |
| PI | Power Influence |
| POTS | Plain Ordinary Telephone Service |
| RD | Resistance Design |
| RDP | Rate Demarcation Point |
| REG | Range Extender with Gain |
| RRD | Revised Resistance Design |
| RT | Remote Terminal |
| T&S | Transmission and Signaling |
| UD | Unigauge Design |
| UL | Underwriter's Laboratory |
| USDL | United States Department of Labor |
| VF | Voice Frequency |
| VG | Voice Grade |

7. Bibliography

- 1- ANSI T1.401-1993, American National Standard for Telecommunications- Interface Between Carriers and Customer Installations - Analog Voice grade Switched Access Lines Using Loop-Start and Ground-Start Signaling.
- 2- Special Report SR-TSV-002275, Issue 2, BOC Notes on T1/T2 C Networks - 1990, Bellecore, 1991.
- 3- IEEE Std 743-1984, IEEE Standard Methods and Equipment for Measuring the Transmission Characteristics of Analog Voice frequency Circuits.
- 4- Generic Requirements GR-63-CORE, Network Equipment-Building System (NEBS) Requirements: Physical Protection, Issue 2, (Bellecore, October 1995).
- 5- Generic Requirements GR-1089-CORE, Electromagnetic Compatibility and Electrical Safety - Generic Criteria for Network Telecommunications Equipment, Issue 2 (Bellecore, November 1994).

6- *Technical Reference FR-NWT-000064, LATA Switching Systems Generic Requirements (LSSGR), (Bellcore, 1994).*

NOTE: These documents are subject to change; references reflect the most current information available at the time of printing. Readers are advised to check the status and availability of all documents.

Appendix A: Loop Design Rules

- 1- Resistance Design (RD) (96% of loops designed prior to 1980)
 - 0 - 1500 ohms, 8.5 dB max
 - Max BT on SL cable = 6 kit
 - POINTS = No loading to 18 kit, H88 loading beyond 18 kit
 - CENTREN = No loading to 11 kit, H88 loading beyond 11 kit
 - Max end section plus BT = 15 kit
 - No loaded BT, No BT between load coils
- 2- Long Route Design (LRD) (3% of loops designed prior to 1980)
 - 1501 - 3600 ohms, 10 dB max
 - Applicable > 18 kit, full H88 loading
 - Gain required for loops over 1600 ohms
 - Max end section plus BT = 12 kit
 - No loaded BT, No BT between load coils
- 3- Ungauge Design (UD) (1% of loops designed prior to 1980)
 - 0 - 2500 ohms, 13 dB max
 - No loading to 24 kit, partial H88 loading beyond 24 kit
 - Gain applied to loops > 15 kit
 - Max BT on SL cable = 6 kit
 - End section plus BT = 12 kit
 - No loaded BT, No BT between load coils
- 4- Modified Resistance Design (MRD) (1980 - 1986)
 - 0 - 1500 ohms, 8.5 dB max
 - Max BT on SL cable = 6 kit
 - Total SL cable plus BT = 15 kit
 - POINTS = No loading to 15 kit, full H88 loading beyond 15 kit
 - CENTREN = No loading to 11 kit, H88 loading beyond 11 kit
 - Loaded cable end section plus BT = 3 to 12 kit
 - No loaded BT, No BT between load coils
- 5- Modified Long Route Design (MLRD) (1980 - 1986)
 - 1501 - 2000 ohms = Res Zone 18
 - 2001 - 2800 ohms = Res Zone 28
 - RZ 18 = Range Extension plus 3 dB of gain, 10 dB max
 - RZ 28 = Range Extension plus 6 dB of gain, 10 dB max
 - Full H88 loading
 - End section plus BT = 3 to 12 kit
 - No loaded BT, No BT between load coils
- 6- Concentrated Range Extension with Gain (CREWG) (1980 - 1986, 1A & 2A LSS On's)
 - 0 - 2800 ohms, 13 dB max
 - No loading to 15 kit, full H88 loading beyond 15 kit
 - Range extension with gain (REG) required for all loops over 1500 ohms
 - REG provided behind a stage of switching concentration
 - Total SL cable plus BT = 15 kit max
 - Max SL cable BT = 6 kit
 - Loaded end section plus BT = 3 to 12 kit
 - No loaded BT, No BT between load coils
- 7- Revised Resistance Design (after 1986)
 - 0 - 15 kit = 1500 ohms max
 - 15 - 24 kit = 1500 ohms max (CO permitting)
 - No loading to 18 kit, full H88 loading between 15 - 24 kit
 - Max SL cable plus BT = 15 kit
 - Max BT on SL cable = 6 kit
 - Loaded cable end section plus BT = 3 to 12 kit
 - No loaded BT, No BT between load coils

EXHIBIT B

EXHIBIT B

72570

Issue 1, December 1996

Bell Atlantic Technical Reference

**Analog Unbundled Loop Service with
Customer Specified Signaling
Technical Specifications**

©1996 Bell Atlantic Network Services, Inc.
All Rights Reserved
Printed in U.S.A.

Bell Atlantic Network Services, Inc.
Technical Reference

TR-72570
Issue I, December 1996

Notice

This Technical Reference is published by Bell Atlantic to provide a technical description of Analog Unbundled Loop Service with Customer Specified Signaling. To the extent feasible, the description references or duplicates existing published technical references utilized by the industry.

Bell Atlantic reserves the right to revise this technical reference for any reason including, but not limited to, changes in tariffs, laws, or regulations, conformity with updates and changes in standards promulgated by various agencies, utilization of advances in the state of technical arts, or the reflection of changes in the design of any facilities, equipment, techniques, or procedures described or referred to herein. Liability for difficulties arising from technical limitations or changes herein is disclaimed.

Bell Atlantic reserves the right not to offer any or all of these services and to withdraw any or all of them at any future time. In addition, the services described herein are based on available facilities and equipment and may not be universally available.

With respect to services offered pursuant to tariff, however, the terms and conditions of the service offering are determined by the tariff itself and applicable laws and regulations. This reference is intended to be supplemental to the tariffs. In the event of a conflict between the tariffs, laws or regulations and this reference, the tariffs, laws, and regulations shall govern.

For additional copies, please contact:

Bell Atlantic Document and Information Delivery Services
1310 N. Court House Road
Arlington, VA 22201
703-974-5887

For information about the technical specification, in this TR, contact:

Trone Bishop
1 East Pratt St.
Baltimore, Md. 21202
410-736-7622

EXHIBIT B

Bell Atlantic Network Services, Inc.
Technical Reference

TR-72570
 Issue 1, December 1996

Bell Atlantic Analog Unbundled Loop Service with Customer Specified Signaling Technical Specifications

| Contents | Page |
|--|-------------|
| 1. General | 1 |
| 2. Service Description | 1 |
| A. General | 1 |
| B. Physical Characteristics | 2 |
| C. Service Elements | 2 |
| D. Compatibility Considerations | 3 |
| 3. Service Element Design Criteria | 3 |
| A. General | 3 |
| B. COTF Wiring and Tie Cable(s) | 3 |
| C. Subscriber Loop Facilities | 4 |
| 4. Service Specifications | 6 |
| A. General | 6 |
| B. Performance | 6 |
| C. Available Signaling | 7 |
| D. Available Options | 9 |
| E. Compatible TLP Ranges | 9 |
| 5. OTC Equipment and CO Cabling Requirements | 10 |
| A. OTC Equipment Requirements | 10 |
| B. OTC CO Cabling Requirements | 11 |
| 6. References | 11 |
| A. Definitions | 11 |
| B. Acronyms | 15 |
| 7. Bibliography | 16 |
| 8. Appendix A: Historical Loop Design Rules | 17 |

| Figures and Tables | Page |
|---|-------------|
| Figure 2-1: Typical 2-Wire AULSCSS configuration | 2 |
| Figure 2-2: Typical 4-Wire AULSCSS configuration | 2 |
| Table 4-1: Acceptance Limits (AL) and Immediate Action Limits (IAL) for AULSCSS channels | 7 |
| Table 4-2: AULSCSS NC Codes | 8 |

Figures and Tables

Page

| | |
|--|---|
| Table 4-3: Compatible AULSCSS OTC-POT NCI Codes | 8 |
| Table 4-4: Compatible AULSCSS NCI Code Combinations | 9 |
| Figure 4-5: Compatible TLP Ranges at the EU-POT and OTC-POI for 2-Wire AULSCSS Channels | 9 |
| Figure 4-6: Compatible TLP Ranges at the EU-POT and OTC-POI for 4-Wire AULSCSS Channels | 9 |

1. General

1.01 This technical reference provides the technical specifications associated with the Analog Unbundled Loop Service with Customer Specified Signaling that is offered by Bell Atlantic. The service may not be universally available.

1.02 Whenever this technical reference is reissued, the reason(s) for reissue will be provided in this paragraph.

1.03 Analog Unbundled Loop Services with Customer Specified Signaling (AULSCSS) enable Other Telephone Companies (OTC) collocated in a Bell Atlantic Central Office (CO) to connect to analog subscriber loops to provide switched access services to end-user locations. AULSCSS provides a 2-wire or 4-wire channel that is suitable for the transport of analog services that use various types of signaling.

1.04 The technical specifications in this document assume that the OTC is collocated in the same CO as the AULSCSS service. In the future, Bell Atlantic may offer transport services for AULSCSS. In that case, the technical specifications associated with the transport service should be consulted.

2. Service Description

A. General

2.01 The description, terms, conditions, rates, regulations, and Universal Service Order Codes (USOCs) for AULSCSS are contained in applicable tariffs or contracts.

2.02 AULSCSS provides the customer with a voice grade transmission channel between the Central Office Distributing Frame (CODF) termination of OTC equipment in a Bell Atlantic CO and the Rate Demarcation Point (RDP) at an end-user customer location.

2.03 AULSCSS channels are suitable for the transport of analog voice grade signals between 300 and 3000 Hz.

2.04 A 2-Wire AULSCSS channel will support either loop-start, ground-start, loop reverse-battery, or customer-provided inband signaling. A 4-wire AULSCSS channel will support either loop-start, ground-start, loop reverse-battery, customer-provided inband, or duplex signaling.

2.05 AULSCSS is provided subject to availability on a first-come first-served basis. Special construction charges apply when appropriate facilities are not available.

B. Physical Characteristics

2.06 AULSCSS channels can be effective 2-wire or 4-wire. When the OTC or RDP interface is 2-wire, one conductor is called tip and the other conductor is called ring. When the OTC or RDP interface is 4-wire the conductors of the OTC or End-User transmit pair are called tip and ring and the conductors of the OTC or End-User receive pair are called tip 1 and ring 1.

2.07 An effective 2-wire AULSCSS channel has 2-wire interfaces at both the OTC POT and the RDP. In addition, an effective 2-wire AULSCSS channel consists entirely of 2-wire facilities or a combination of 2-wire and 4-wire facilities. A typical 2-wire AULSCSS configuration is shown in Figure 2-1.

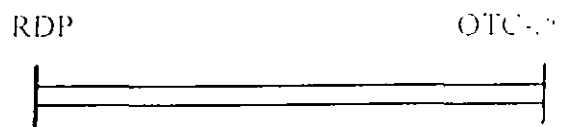

Figure 2-1: Typical 2-Wire AULSCSS configuration

2.08 A 4-wire AULSCSS channel has 4-wire interfaces at both the OTC POT and the RDP. In addition, the 4-wire AULSCSS channel consists entirely of 4-wire facilities with no 2-wire segments. A typical 4-wire AULSCSS configuration is shown in Figure 2-2.

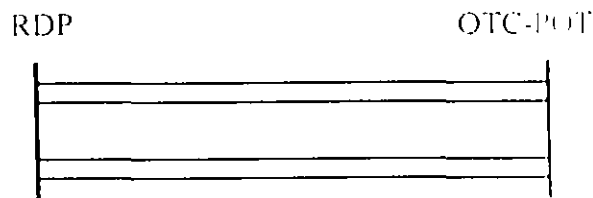

Figure 2-2: Typical 4-Wire AULSCSS configuration

2.09 AULSCSS channels may be provided using a variety of subscriber loop transmission technologies, including but not limited to, metallic cable, metallic cable based digital loop carrier, and fiber optic digital loop carrier systems.

C. Service Elements

2.10 AULSCSS ordinarily consists of two elements:

- (1) the CODF wire and tie cable(s).
- (2) a subscriber loop facility between the CODF and the end-user customer's RDP. The loop facility is either:

(a) a metallic facility consisting of cable and wire between the CODF and the RDP; or,

(b) a DLC facility channel with loop start (LS), ground start (GS), loop reverse battery (RV), or duplex (DX) signaling capability, or transmission-only (TO) capability for customer inband signaling applications, that consists of:

- CO cabling between the CODF and a DLC COF that is equipped with an LS, GS, RV, DX, or TO channel unit,
- a fiber or metallic facility from the DLC COF to the DLC RT that is equipped with an LS, GS, RV, DX, or TO channel unit, and,
- cable and wire between the DLC RT and the RDP.

D. Compatibility Considerations

2.11 Electronic transmission and signaling (T&S) enhancement equipment is not ordinarily used with AULSCSS. Examples of T&S are:

- (a) a transmission repeater, or
- (b) a transmission repeater with a signaling repeater, or
- (c) a transmission repeater with signaling battery boost equipment.

2.12 If the OTC needs T&S equipment with AULSCSS to accommodate an OTC service, the OTC will be responsible for providing any such T&S equipment.

3. Service Element Design Criteria

A. General

3.01 Two elements are always used with AULSCSS. They are: CODF (wire and tie cable(s)), and subscriber loop facilities. The sections which follow contain the specifications for each of these elements.

B. CODF Wiring and Tie Cable(s)

3.02 CODF cross-connect wiring and tie cable(s) are used to link the CODF termination of OTC equipment to the CODF termination of metallic subscriber loops, DLC COFs, and electronic transmission and signaling enhancement equipment.

3.03 The total combined length of all CODF cross-connect wiring and all CODF-to-CODF tie cables between the CODF termination of the OTC equipment and the CODF termination of any subscriber loop in the same CO should be less than 1500 feet.

3.04 The direct-current resistance between the CODF termination of the OTC equipment and the CODF termination of any subscriber loop in the same CO should be less than 125 ohms. This is equal to 1500 or less feet of 26 gauge cable.

3.05 The 1kHz loss between the CODF termination of the OTC equipment and the CODF termination of a subscriber loop in the same CO, when measured between 900 ohm impedances, should be less than .85 dB.

3.06 The C-message noise measured on the wiring and tie cables between the CODF termination of the OTC equipment and the CODF termination of a subscriber loop in the same CO shall be 20 dBmC or less.

C. Subscriber Loop Facilities

3.07 Subscriber loop facilities consist of feeder and distribution plant between the CODF and the end-user customer's RDP. Feeder plant uses a variety of transmission technologies, including but not limited to, twisted-pair metallic cables, twisted-pair metallic cable based digital loop carrier, and fiber optic based digital loop carrier. Distribution plant usually consists of multipair metallic cables. Additional information about subscriber loops may be found in Bellecore SR-TSV-002275 [1].

3.08 A twisted-pair metallic loop facility consists entirely of metallic cable and wire between the CODF and the end-user customer's RDP. Most metallic loops consist of multipair cables, laid out on aerial, underground, or buried routes to suit the needs of a particular community. The metallic loop facility may be loaded or non-loaded. It may also have bridged-tap. Loaded bridged-tap and bridged tap between load coils are not permitted.

3.10 A universal DLC facility consists of CO cabling between the CODF and a DLC COF, OSP fiber or metallic cable facilities from the DLC COF to the DLC RFT, and cable and wire between the DLC RFT and the end-user customer's RDP. Some universal DLC wiring also support enhanced services such as distinctive ringing, forward disconnect, caller ID, etc.

3.11 Subscriber loop facilities have been designed on a global basis primarily to accommodate POTS and guarantee that loop transmission loss is statistically distributed and that no single loop exceeds the signaling range of the CO.

3.12 Prior to 1980, loops were designed using one of the following design plans: Resistance Design (RD), Long Route Design (LRD), or Unigauge Design (UD). From 1980 to 1986, the Modified Resistance Design (MRD), Modified Long Route Design (MLRD), and Concentrated Range Extension with Gain (CREG) plans were applied on a going-forward basis (i.e., retroactive

redesign was not implemented). In 1986, the Revised Resistance Design (RRD) plan was applied on a going-forward basis. Appendix A provides a summary of the various loop design plans.

3.13 Most metallic loop facilities (98%) were designed using the RD, MRD, or RRD design rules. The RRD design rules currently in use limit the loop resistance to the design range of the CO switch or 1500 ohms whichever is less. CO switches have a range of either 1300 or 1500 ohms. The 1 kHz loss of RRD loops is 8.5 dB or less.

3.14 A small number of loops have been designed using the LRD, MLRD, UD, and CREG design plans. These loops are long (15+kt) and have high resistance (up to 2800 or 3600 ohms) and high loss (up to 13 dB without gain). Such loops require electronic transmission and signaling range enhancement equipment to accommodate AULSCSS. The LRD and MLRD design plans use Range Extension with Gain (REG) equipment that is either dedicated to each loop or hard-wired to the BA CO line equipment. In the latter case, the hard-wired REG is not available for use on AULSCSS.

3.15 The REG equipment used with CREG designed loops is implemented behind a stage of switching concentration in the associated CO switch. This permits REG equipment to be shared with other loops working out of the same CO switch. For this reason, the REG associated with CREG designed loops is not available for use on AULSCSS.

3.16 Bell Atlantic will work with the OTC to explore available options when an LRD, MLRD, or CREG designed loop requires enhancement to support AULSCSS.

3.17 The direct-current resistance of a metallic loop facility measured between the CODF and the RDP shall be 1520 ohms or less if the facility was designed using RD, MRD, or RRD rules. The resistance will be less than 2500 ohms if the facility was designed using UD rules, less than 2800 ohms if the facility was designed using CREG or MLRD rules, and less than 3600 ohms if the facility was designed using LRD rules.

3.18 The 1kHz loss of a metallic loop facility when measured with a 600 ohm impedance at the CODF and a 600 ohm impedance at the RDP shall be 8.0 dB or less if the loop was designed using RD, MRD, or RRD rules. The loss will be 10 dB or less if the loop was designed using LRD or MLRD rules, and 13 dB or less if the loop was designed using UD or REG rules.

3.19 The C-message noise measured on a metallic subscriber loop at the RDP shall be less than 30 dBmC.

3.20 The leakage resistance between the tip conductor and ground, the ring conductor and ground, and tip and ring conductors of a loop should each be greater than 100 K ohms.

3.21 The Power Influence (PI) measured per IEEE Std 743-1984 (2) on the metallic portion of a loop should be less than 90 dBmC.

3.22 For LS and GS signaling, the DLC facilities provide a battery feed to the RDP. When the RDP is terminated by a direct-current resistance of 430 ohms or less, the loop current supplied by the DLC in such cases shall be 20 mA or greater.

3.23 The 1kHz loss of a DLC facility when measured with a 900 ohm impedance at the COTF and a 600 ohm impedance at the RDP shall be 8 dB or less.

3.24 The C-message noise measured on a DLC facility shall be 23 dBmC or less.

3.25 The C-Notched noise measured on a DLC facility shall be 36 dBmC or less with a -13 dBm0, 1004 Hz holding tone.

3.26 The impulse noise measured on a DLC facility shall be no more than 15 counts in 15 minutes with a threshold of 59 dBmC.

3.27 The echo return loss and singing return loss of a subscriber loop facility measured with a 900 ohm + 2.16 uf reference at the COTF and a 600 ohm + 2.16 uf termination at the RDP shall be equal to or greater than 5.5 dB and 2.5 dB respectively.

3.28 Subscriber loop facilities shall meet all applicable design specifications. (See appendix A)

4. Service Specifications

A. General

4.01 The overall end-to-end AULSCSS service is from the COTF appearance of the collocated OTC equipment to the end-user customer's RDP. AULSCSS service will use the TXNU service code.

B. Performance

4.02 Loss and C-Message noise will be measured during acceptance testing of new services at turn-up. Services that reuse existing working loops are only tested for continuity at turn-up.

4.03 Other parameters are tested in response to trouble reports or when additional testing is purchased.

4.04 The acceptance limits and immediate action limits in Table 4-1 apply to AULSCSS channels.

4.05 When a AULSCSS channel is provided using DLC, the transmission performance of the channel is evaluated by measuring performance parameters on the overall end-to-end service.

Table 4-1
Acceptance Limits (AL) and Immediate Action Limits (IAL)
for AULSCSS channels

| PARAMETER | AL | IAL |
|--------------------------|-----------------|-----------------|
| Loss | < 8.5 dB | > 10.0 dB |
| Resistance | < 1520 ohms | > 1520 ohms |
| Three-Tone Slope* | -1.5 to +5.5 dB | -2.0 to +6.5 dB |
| C-Message Noise | < 30 dBmC0 | > 30 dBmC0 |
| C-Notched Noise | < 36 dBmC0 | > 36 dBmC0 |
| Leakage | > 100 kohms | 100 kohms |
| Echo Return Loss | > 5.5 dB | > 5.5 dB |
| Singing Return Loss | > 2.5 dB | < 2.5 dB |
| Power Influence | < 90 dB | > 90 dB |
| LS/GS Loop Current (DLC) | > 20 mA | < 20 mA |

* Minus (-) means less loss and plus (+) means more loss.

C. Available Signaling

4.06 The following 2-wire signaling capability is available where facilities and equipment permit:

- No signaling (includes inband signaling furnished by the OTC).
- Loop-start closed-end at end-user RDP and loop-start open-end at the OTC-POT.
- Loop-start open-end at end-user RDP and loop-start closed-end at the OTC-POT.
- Ground-start closed-end at end-user RDP and ground-start open-end at the OTC-POT.
- Ground-start open-end at end-user RDP and ground-start closed-end at the OTC-POT.
- Loop reverse-battery terminating at the end-user RDP and loop reverse-battery originating at the OTC-POT.
- Loop reverse-battery originating at the end-user RDP and loop reverse-battery terminating at the OTC-POT.

4.07 The following 4-wire signaling capability is available where facilities and equipment permit:

- No signaling (includes inband signaling furnished by the OTC).
- Loop-start closed-end at end-user RDP and loop-start open-end at the OTC-POT.
- Loop-start open-end at end-user RDP and loop-start closed-end at the OTC-POT.
- Ground-start closed-end at end-user RDP and ground-start open-end at the OTC-POT.
- Ground-start open-end at end-user RDP and ground-start closed-end at the OTC-POT.
- Loop reverse-battery terminating at the end-user RDP and loop reverse-battery originating at the OTC-POT. This signaling capability is not available on a 4-wire basis when the loop facility includes DLC.

- Loop reverse-battery originating at the end-user RDP and loop reverse-battery terminating at the OTC-POT. This signaling capability is not available on a 4-wire basis when the loop facility includes DLC.
- Duplex (DX) signaling at EU-POT and OTC-POT.

4.08 The signaling associated with 4-wire interfaces can be derived from the associated simplex leads. BA provides the standard simplex sense for all 4-wire interfaces, that is, the B-lead or Ring conductor can be derived from the OTC and EU receive pair and the A-lead or Tip conductor can be derived from the OTC and EU transmit pair.

4.09 AULSCSS Network Channel (NC) codes and Network Channel Interface (NCI) codes are shown in the following figures: Figure 4-2 shows NC codes; Figure 4-3 shows OTC-POT NCI codes; and Figure 4-4 shows compatible NCI code combinations. Additional information concerning NC/NCI codes may be found in Bellecore SR-STS-00030733.

Figure 4-2: AULSCSS NC Codes

| NC Code | Character 3 | Character 4 |
|---------|-------------|-------------|
| LX | - | - |

Figure 4-3: AULSCSS OTC-POT NCI Codes

| NCI Code | Description |
|-----------|--|
| 02QC3.OOB | 2-Wire Ground-start signaling - Open End |
| 02QC3.OOC | 2-Wire Ground-start signaling - Closed End |
| 02QC3.OOD | 2-Wire Loop-start signaling - Open End |
| 02QC3.OOE | 2-Wire Loop-start signaling - Closed End |
| 02QC3.OOF | 2-Wire Transmission Only - No Signaling |
| 02QC3.RVO | 2-Wire Reverse-Battery - OTC Originating |
| 02QC3.RVT | 2-Wire Reverse-Battery - OTC Terminating |
| 04QC2.DXO | 4-Wire Duplex Signaling |
| 04QC2.OOB | 4-Wire Ground-start signaling - Open End |
| 04QC2.OOC | 4-Wire Ground-start signaling - Closed End |
| 04QC2.OOD | 4-Wire Loop-start signaling - Open End |
| 04QC2.OOE | 4-Wire Loop-start signaling - Closed End |
| 04QC2.OOF | 4-Wire Transmission Only - No Signaling |
| 04QC2.RVO | 4-Wire Reverse-Battery - OTC Originating |
| 04QC2.RVT | 4-Wire Reverse-Battery - OTC Terminating |

Figure 4-4: Compatible AULSCSS NCI Code Combinations

| EU-POT | OTC-POT |
|----------|-----------|
| 02GO2 | 02QC3.OOC |
| 02GS2 | 02QC3.OOB |
| 02LO2 | 02QC3.OOE |
| 02LS2 | 02QC3.OOD |
| 02NO2 | 02QC3.OOF |
| 02RV2.T | 02QC3.RVO |
| 02RV2.O | 02QC3.RVT |
| 04GO2 | 04QC2.OOC |
| 04GS2 | 04QC2.OOB |
| 04LO2 | 04QC2.OOE |
| 04LS2 | 04QC2.OOD |
| 04NO2 | 04QC2.OOF |
| 04RV2.T* | 04QC2.RVO |
| 04RV2.O* | 04QC2.RVT |
| 04DX2 | 04QC2.DXO |

* 04RV2.T and 04RV2.O are not available when DLC facilities are used.

D. Available Options

4.09 No options are available for AULSCSS channels.

E. Compatible TLP Ranges

4.10 Compatible TLP ranges are shown in Figures 4-5 and 4-6.

Figure 4-5: Compatible TLP Ranges at the EU-POT and OTC-POT for 2-Wire AULSCSS Channels

| Specified Protocol Code | EU/OTC Transmit TLP | EU/OTC Receive TLP |
|-------------------------|---------------------|--------------------|
| GO, GS, LO, LS, NO, RV | 0 | 0 to -8.5 # |

In general, the receive TLP is a function of the cable loss.

Figure 4-6: Compatible TLP Ranges at the EU-POT and OTC-POT for 4-Wire AULSCSS Channels

| Specified Protocol Code | EU/OTC Transmit TLP | EU/OTC Receive TLP |
|----------------------------|---------------------|--------------------|
| DX, GO, GS, LO, LS, NO, RV | 0 | 0 to -8.5 # |

In general, the receive TLP is a function of the cable loss.

5. OTC Equipment and CO Cabling Requirements

A. OTC Equipment Requirements

5.01 Several different types of OTC equipment can connect to AULSCSS. The equipment can be collocated in a BA CO or located at the end-user premises. Examples are: transport equipment; transmission repeaters; transmission repeaters with loop signaling repeaters; transmission repeaters with signaling battery boost equipment; and special service channel units.

5.02 Co-located OTC equipment used for interconnection with AULSCSS shall meet all applicable requirements including those in this document as well as applicable generic equipment requirements in Bellcore documents GR-63-CORE [4] and GR-108-CORE [5].

5.03 Co-located OTC equipment shall be manufactured in accordance with FCC, NEC, UL, and USDL requirements and orders applicable to Federal, State, and local requirements including, but not limited to, statutes, rules, regulations, orders, or ordinances, or otherwise imposed by law. Where requirements are not specified in this document, contractual technical requirements or other applicable documents, the manufacturer's requirements consistent with industry standards shall be met.

5.04 The open circuit tip-to-ring dc voltage that OTC equipment applies to BA cabling shall be less than 80 Vdc.

5.05 OTC equipment shall not deliver more than 2.5 watts of power to any load via BA cable.

5.06 OTC equipment shall not deliver more than 150 mA of loop current to any load via BA cable.

5.07 The noise limits for AULSCSS are predicated on the OTC equipment having a longitudinal balance of > 60 dB.

5.08 The impedance of OTC equipment shall be a nominal 900 ohms when collocated in a BA CO and a nominal 600 ohms when used on the end-user premises at or near the RDP.

5.09 The applied power level of any signal transmitted on AULSCSS averaged over 3 seconds shall not exceed -13 dBm0.

5.10 AULSCSS loops may be exposed to electrical surges from lightning and commercial power system disturbances. Despite protective devices on the CODF, some of these disturbances are likely to reach OTC equipment. OTC equipment shall be designed to withstand certain surges without being damaged, and shall fail in a safe manner under infrequent high stress.

5.11 The prevalent voltage-limiting device available for CO use is the 3-mil carbon block. This device has an upper 3 σ limiting voltage of 1000 volts peak under surge conditions and 600 volts rms (800 peak) at 60 Hz. OTC equipment connected to AULSCSS subscriber loop facilities protected by carbon blocks may be subjected to voltages up to these levels. Unexposed COs may

not have primary protection, and OTC equipment not coordinating with carbon blocks may need protection in these locations.

5.12 If the AULSCSS subscriber loop facility is exposed to commercial power, the CO protector may also include 350 mA heat coils for limiting the current that is permitted to flow to CO equipment. In addition, a protective fuse cable located outside the CO incorporating 24 or 26 AWG conductors to coordinate with the protector, serves to limit current to safe levels in the event of prolonged operation of the protector during power fault conditions.

B. OTC CO Cabling Requirements

5.13 The voice grade CO cabling used to terminate collocated OTC equipment on the CODF shall use twisted-pair conductors.

5.14 The type, gauge, and length of the OTC CODF cabling shall be specified based on this specification and OTC equipment requirements. If the specifications in this document differ from the OTC equipment manufacturers specifications, then the more stringent of the two shall be used.

5.14 The direct-current resistance of the CO cabling between the OTC equipment and the CODF shall meet the CO cabling requirements in the Belleore FR-TSY-000-0416] (i.e., 23 ohms or less). This is equivalent to 275 feet or less of 26 gauge cable, 440 feet or less of 24 gauge cable, and 700 feet or less of 22 gauge cable.

5.15 All CO cabling between OTC equipment and the CODF shall be connected as specified by the BA CO Engineer.

5.16 The 1kHz loss of the CO cabling between the OTC equipment and the CODF, when measured between 900 ohm impedances, shall be less than .15 dB.

5.17 The C-message noise measured on the CO cabling between the OTC equipment and the CODF shall be 20 dBmC or less.

6. References

A. Definitions

Acceptance Limit (AL)

The maximum value of, or deviation, that is allowed at service turnup or IC acceptance.

Analog Unbundled Loop Service with Customer Specified Signaling (AULSCSS)

A service that provides an analog facility between a BA CO and a customer location that is capable of supporting signaling specified, at the time the service is ordered, by the customer.

Central Office (CO)

A telephone company building which houses equipment and facilities used to provide switched access services.

Central Office Distributing Frame (CODF)

Framework located in a CO that holds wire cross-connects which are used to interconnect cable terminations for end-user customer loops, switching system ports, and inter-office facilities.

C-Message Noise

The frequency-weighted, short-term average noise within an idle channel. The frequency weighting, called C-message, is used to account for the variations in 500-type telephone set transducer efficiency and end-user annoyance to tones as a function of frequency.

C-Notched Noise

The C-message frequency-weighted noise on a channel with a holding tone that is removed at the measuring end through a notch (very narrow band) filter.

Channel

An electrical, or photonic communications path between two or more points of transmission.

Closed End

The end of a switched access service that receives ringing and dial tone and transmits address signals.

dBm

A unit used to express power level in decibels relative to one milliwatt.

dBm0

A unit used to express power level referred to, or measured at, a zero transmission level point (OTLP).

dB_{rn}

A unit used to express noise power relative to one picowatt (-90 dBm).

dB_{rnC}

A unit used to express noise power relative to one picowatt measured with C-message weighting.

dB_{rnC0}

A unit used to express noise power in dB_{rnC} referred to, or measured at, a zero transmission level point (OTLP).

Decibel (dB)

The logarithmic unit of signal power ratio most commonly used in telephony. It is used to express the relationship between two signal powers, usually between two acoustic, electric, or optical signals; it is equal to ten times the common logarithm of the ratio of the two signal powers.

Duplex Signaling

A type of dc signaling that employs symmetrical and balanced signaling equipment at each end of the loop. One simplex conductor of the 4-wire loop is used for signaling and the other simplex conductor is used for ground potential compensation.

Echo Return Loss (ERL)

A frequency-weighted measure of return loss over the middle of the voiceband (approximately 560 to 1965 Hz), where talker echo is most annoying. (See Table 9 of IEEE Std. 743-1984)

End User (EU)

The term "end user" denotes any customer of a telecommunications service that is not a carrier, except that a carrier shall be deemed to be an "end user" to the extent that such a carrier uses a telecommunications service for administrative purposes, without making such a service available to others, directly, or indirectly.

End-User Point Of Termination (EU-POT)

The rate demarcation point (RDP) on an end user's premises at which Bell Atlantic's responsibility for the provision of the services described in this document ends.

Facilities

Any cable, poles, conduit, microwave, or carrier equipment, central office distributing frames, central office switching equipment, computers (both hardware and software), business machines, etc., utilized to provide the services offered by a telephone company.

Immediate Action Limit (IAL)

The bound of acceptable performance and the threshold beyond which BA will accept a customer's trouble report and take immediate corrective action.

Impulse Noise

Any momentary occurrence of noise on a channel that significantly exceeds the normal noise peaks. Impulse noise is analyzed by counting the number of occurrences that exceed a threshold.

Leakage

The resistance between the conductors of an insulated metallic pair or the resistance between each conductor of an insulated metallic pair and ground.

Loop Reverse-Battery Signaling

A type of switched access line dc signaling that uses loop-open and loop-closure signals to indicate on-hook and off-hook signals in one direction and normal battery polarity and reverse battery polarity to indicate on-hook and off-hook signals in the other direction. The end of the service that generates loop open and loop closure signals is called the originating end and the other end which generates the normal battery polarity and reverse battery polarity signals is called the terminating end.

Loop-start (LS) Signaling

A type of switched access line signaling in which the network provides a battery source. To initiate a call, customer premises equipment will provide a loop closure that causes dc loop current to flow which the network will detect.

Open End

The end of a switched access service that transmits ringing and dial tone and receives address signaling.

Other Telephone Company (OTC)

An organization that provides telecommunications services to the public.

Plain Ordinary Telephone Service (POTS)

The basic single line switched access service offered by local exchange carriers to residential and business customers. POTS uses loop-start signaling.

Power Influence (PI)

The power of a longitudinal signal induced in a metallic OSP facility by an electromagnetic field emanating from a conductor or conductors of a power system. PI is also called longitudinal noise or noise-to-ground.

Protocol Code

In general, a component of the Network Channel Interface (NCI) code that identifies the basic electrical function of the interface. For AULSCSS, the protocol codes (i.e., DX, GO, GS, LO, LS, NO and RV) identify the type of signaling if any.

Rate Demarcation Point (RDP)

The point at which Bell Atlantic network access recurring charges and responsibility stop and beyond which customer responsibility begins. The RDP is the point of demarcation and/or interconnection between a Bell Atlantic subscriber loop facility and end-user premises cabling or terminal equipment. Bell Atlantic facilities at, or constituting, the rate demarcation point shall consist of wire or a jack conforming to Subpart F of Part 68 of FCC rules.

Return Loss (RL)

A measure of the similarity between the two impedances at a junction. The higher the return loss, the higher the similarity. It is the ratio (in decibels) of the power incident upon the junction to the power reflected from the junction. If the two impedances at the junction are Z1 and Z2, then:

$$\text{return loss} = 20 \log \frac{|Z1 + Z2|}{|Z1 - Z2|} \text{ dB}$$

Signal-to-Noise Ratio (S/N Ratio)

The ratio of the signal power to the noise power at a given point in a given system (usually expressed in decibels).

Singing Return Loss (SRL)

The frequency-weighted measure of return loss at the edges of the voiceband (SRL Low, 260 to 500 Hz and SRL High, 2200 to 3400 Hz), where singing (instability) problems are most likely to occur.

Signaling Repeater

Loop enhancement equipment that detects and regenerates signaling states.

Three-Tone Slope

The loss at 404 Hz and 2804 Hz relative to the loss at 1004 Hz.

Transmission Level Point (TLP)

A point in a transmission system at which the ratio, usually expressed in decibels, of the power of a test signal at that point to the power of the test signal at a reference point, is specified.

Transmission Repeater

Loop enhancement equipment that amplifies and equalizes voice grade signals.

Unbundled Loop

A transmission channel between a end-user customer location and a LEC CO that is not a part of, or connected to, other LEC services.

Voice Grade (VG)

A term used to describe a channel, circuit, facility, or service that is suitable for the transmission of speech, digital or analog data, or facsimile, generally with a frequency range of about 300 to 3000 Hz.

B. Acronyms

| | |
|---------|---|
| ANSI | American National Standards Institute |
| AULSCSS | Analog Unbundled Loop Service with Customer Specified Signaling |
| BA | Bell Atlantic |
| CO | Central Office |
| CODF | Central Office Distributing Frame |
| COT | Central Office Terminal |
| CREG | Concentrated Range Extension with Gain |
| DLC | Digital Loop Carrier |
| GS | Ground-Start |
| LRB | Loop Reverse-Battery |
| LRD | Long Route Design |
| LS | Loop-Start |
| MLRD | Modified Long Route Design |
| MRD | Modified Resistance Design |
| OTC | Other Telephone Company |

| | |
|------|---|
| PI | Power Influence |
| POTS | Plain Ordinary (analog) Telephone Service |
| RD | Resistance Design |
| RDP | Rate Demarcation Point |
| REG | Range Extender with Gain |
| RRD | Revised Resistance Design |
| RT | Remote Terminal |
| TO | Transmission Only |
| T&S | Transmission and Signaling |
| UD | Unigauge Design |
| VF | Voice Frequency |
| VG | Voice Grade |

7. Bibliography

- 1- Special Report SR-TSV-002275, Issue 2, *BOC Notes on the LEC Networks*, Bellcore, April 1994.
- 2- IEEE Std 743-1984, *IEEE Standard Methods and Equipment for Measuring the Transmission Characteristics of Analog Voice Frequency Circuits*.
- 3- Special Report SR-STS-000307, Issue 3, *Industry Support Interface (ISI): NC/NCI Code Dictionary*, Bellcore, January 1992.
- 4- Generic Requirements GR-63-CORE, *Network Equipment-Building System (NEBS) Requirements: Physical Protection*, Issue 1, (Bellcore, October 1995).
- 5- Generic Requirements GR-1089-CORE, *Electromagnetic Compatibility and Electrical Safety - Generic Criteria for Network Telecommunications Equipment*, Issue 1 (Bellcore, November 1994).
- 6- Technical Reference FR-NWT-000064, *LATA Switching Systems Generic Requirements (LSSGR)*, (Bellcore, 1994).

NOTE: These documents are subject to change; references reflect the most current information available at the time of printing. Readers are advised to check the status and availability of all documents.

Appendix A Historical Loop Design Rules

- 1- Resistance Design (RD) (96% of loops designed prior to 1980)
 - 0 - 1500 ohms
 - Max BT on NL cable = 6 kft
 - POFS = No loading to 13 kft, H88 loading beyond 13 kft
 - CENTREN = No loading to 11 kft, H88 loading beyond 11 kft
 - Max end section plus BT = 15 kft
 - No loaded BT, No BT between load coils
- 2- Long Route Design (LRD) (3% of loops designed prior to 1980)
 - 1301 - 3600 ohms
 - Applicable > 18 kft, full H88 loading
 - Gain required for loops over 1600 ohms
 - Max end section plus BT = 12 kft
 - No loaded BT, No BT between load coils
- 3- Ungauge Design (UD) (1% of loops designed prior to 1950)
 - 0 - 2500 ohms
 - No loading to 24 kft, partial H88 loading beyond 24 kft
 - Gain applied to loops > 15 kft
 - Max BT on NL cable = 6 kft
 - End section plus BT = 12 kft
 - No loaded BT, No BT between load coils
- 4- Modified Resistance Design (MRD) (1980 - 1986)
 - 0 - 1500 ohms
 - Max BT on NL cable = 6 kft
 - Total NL cable plus BT = 15 kft
 - POFS = No loading to 15 kft, H88 loading beyond 15 kft
 - CENTREN = No loading to 11 kft, H88 loading beyond 11 kft
 - Loaded cable end section plus BT = 3 to 12 kft
 - No loaded BT, No BT between load coils,
- 5- Modified Long Route Design (MLRD) (1980 - 1986)
 - 1501 - 2000 ohms = Res Zone 18
 - 2001 - 2800 ohms = Res Zone 28
 - RZ 18 = Range Extension plus 3 dB of gain
 - RZ 28 = Range Extension plus 6 dB of gain
 - Full H88 loading
 - End section plus BT = 3 to 12 kft
 - No loaded BT, No BT between load coils
- 6- Concentrated Range Extension with Gain (CREG) (1989 - 1996, LA & 2A FSS Only)
 - 0 - 2800 ohms
 - No loading to 15 kft, full H88 loading beyond 15 kft
 - Range extension with gain (REG) required for all loops over 1500 ohms
 - REG provided behind a stage of switching concentration
 - Total NL cable plus BT = 15 kft max
 - Max NL cable BT = 8 kft
 - Loaded end section plus BT = 3 to 12 kft
 - No loaded BT, No BT between load coils
- 7- Revised Resistance Design (after 1986)
 - 0 - 18 kft = 1500 ohms max
 - 18 - 24 kft = 1500 ohms max (CO permitting)
 - No loading to 18 kft, full H88 loading between 18 - 24 kft
 - Max NL cable plus BT = 18 kft
 - Max BT on NL cable = 6 kft
 - Loaded cable end section plus BT = 3 to 12 kft
 - No loaded BT, No BT between load coils

EXHIBIT C

EXHIBIT C

TR 72575
Issue 1, October 1996

Bell Atlantic Technical Reference

**Digital Unbundled Loop Services
Technical Specifications**

© 1996 Bell Atlantic Network Services, Inc.
All Rights Reserved
Printed in U.S.A.

Bell Atlantic Network Services, Inc.
Technical Reference

TR-72575
Issue 1, October 1996

Notice

This Technical Reference is published by Bell Atlantic to provide a technical description of digital unbundled loop services. To the extent feasible, the description references or duplicates existing published technical references utilized by the industry.

Bell Atlantic reserves the right to revise this technical reference for any reason including, but not limited to, changes in tariffs, laws, or regulations, conformity with updates and changes in standards promulgated by various agencies, utilization of advances in the state of technical arts, or the reflection of changes in the design of any facilities, equipment, techniques, or procedures described or referred to herein. Liability for difficulties arising from technical limitations or changes herein is disclaimed.

Bell Atlantic reserves the right not to offer any or all of these services and to withdraw any or all of them at any future time. In addition, the services described herein are based on available facilities and equipment and may not be universally available.

With respect to services offered pursuant to tariff, however, the terms and conditions of the service offering are determined by the tariff itself and applicable laws and regulations. This reference is intended to be supplemental to the tariffs. In the event of a conflict between the tariffs, laws or regulations and this reference, the tariffs, laws, and regulations shall govern.

For additional copies, please contact:

Bell Atlantic Document and Information Delivery Services
1310 N. Court House Road
Arlington, VA 22201
703-974-5887

For information about the technical specifications in this TR, contact:

Trone Bishop
410-736-7622
Fax 410-736-7622
Arlington, VA 22201

EXHIBIT C

Bell Atlantic Network Services, Inc.
Technical Reference

TR 72575
Issue 1, October 1996

Bell Atlantic
Digital Unbundled Loop Services
Technical Specifications

| Contents | Page |
|---|-------------|
| 1. General | 1 |
| 2. Service Description | 1 |
| A. General | 1 |
| B. ISDN Basic Rate Unbundled Loop Service (IBRULS) | 1 |
| C. DS1 (1.544 Mbps) Unbundled Loop Service (DS1ULS) | 3 |
| D. High-Bit-Rate Digital Unbundled Loop Service (HDULS) | 4 |
| E. Asymmetrical Digital Unbundled Loop Service (ADULS) | 4 |
| F. Service Elements | 4 |
| 3. Element Specifications | 5 |
| A. General | 5 |
| B. CODF Wiring and Tie Cable(s) | 6 |
| C. Subscriber Loop Facilities | 6 |
| D. Transmission Enhancement Equipment | 8 |
| 4. Service Specifications | 8 |
| A. General | 8 |
| B. IBRULS | 9 |
| C. DS1ULS | 9 |
| D. HDULS | 12 |
| E. ADULS | 12 |
| 5. OTC Equipment and CO Cabling Requirements | 12 |
| A. OTC Equipment Requirements | 12 |
| B. OTC Equipment CO Cabling Requirements | 13 |
| 6. References | 14 |
| A. Definitions | 14 |
| B. Acronyms | 17 |
| 7. Bibliography | 18 |

| Figures | Page |
|--|-------------|
| Figure 2-1: Typical 2-Wire IBRULS configuration | 2 |
| Figure 2-2: Typical 4-Wire DS1ULS configuration | 3 |
| Figure 4-1: IBRULS NC Codes | 9 |
| Figure 4-2: IBRULS NCI Code Combinations | 9 |
| Figure 4-3: IBRULS Acceptance Limits (AL) and Immediate Action Limits (IAL) | 9 |
| Figure 4-4: DS1ULS NC Codes | 10 |
| Figure 4-5: DS1ULS NCI Code Combinations | 10 |
| Figure 4-6: DS1ULS Performance Objectives | 10 |
| Figure 4-7: DS1ULS Test Limits | 11 |
| Figure 4-8: AMI and B8ZS Test Matrix | 12 |

1. General

1.01 This technical reference provides the technical specifications associated with the Digital Unbundled Loop Services offered by Bell Atlantic (BA) in the co-carrier section of local exchange tariffs. All of the services described in this document may not be available in every jurisdiction.

1.02 Whenever this technical reference is reissued, the reason(s) for reissue will be provided in this paragraph.

1.03 Digital unbundled loop services enable Other Telephone Companies (OTC) that are co-located in a BA Central Office to connect to BA subscriber loops that are designed to support digital services including Integrated Services Digital Network (ISDN) services.

1.04 The following digital unbundled loop services are defined: ISDN Basic Rate and DSL. HDSL and ADSL unbundled loop services are under study.

1.05 The technical specifications in this document assume that the OTC is co-located in the same CO as the digital unbundled loop service. In the future, BA may offer transport services for digital unbundled loop services. In that case, the technical specifications associated with the transport service should be consulted.

2. Service Description

A. General

2.01 The description, terms and conditions, rates, regulations, and Universal Service Order Codes (USOCs) for digital unbundled loop services are contained in applicable tariffs or contracts.

2.02 Digital unbundled loop services are provided subject to availability on a first-come first-served basis. Special construction charges apply when appropriate facilities are not available.

2.03 Digital unbundled loop services provide the OTC with a transmission channel suitable for the transport of certain digital services. The channel is between the Central Office Distributing Frame (CODF) or DSX-1 termination of OTC equipment in a BA Central Office (CO) and the Rate Demarcation Point (RDP) at an End User (EU) customer location.

B. ISDN Basic Rate Unbundled Loop Service (IBRULS)

2.04 IBRULS provides the OTC with an effective 2-wire channel that is suitable for the transport of 160 kbps digital signals in both directions simultaneously using the 2B1Q line code.

2.05 The interface at the OTC CODF termination is 2-wire and the interface at the EU-RDP is 2-wire. At each interface one conductor is called tip and the other conductor is called ring.

2.06 The transmission channel between the IBRULS 2-wire interfaces is effective 2-wire. An effective 2-wire channel may be entirely 2-wire or it may contain a 4-wire facility portion (such as a Digital Loop Carrier) with a 2-wire metallic extension to the EU-RDP. A typical IBRULS configuration is shown in Figure 2-1.

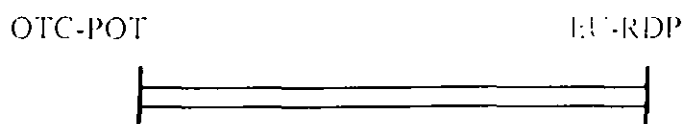

Figure 2-1: Typical 2-Wire IBRULS configuration

2.07 IBRULS supports full duplex 160 kbps digital transmission. The 160 kbps ISDN Basic Rate supports a 16 kbps overhead channel for performance monitoring, framing, synchronization, and maintenance. In addition, the line rate supports 144 kbps of payload data which is divided into three channels, two 64 kbps "B" (Bearer) channels and one 16 kbps "D" (Data) channel.

2.08 IBRULS supports the standard ISDN Basic Rate Two-Binary One-Quaternary (2B1Q) line code. Vendor-specific, non-standard line codes are not supported and Bell Atlantic spectrum management rules do not permit their deployment.

2.09 IBRULS may be provided using a variety of loop transmission technologies, including but not limited to, metallic cable, metallic cable based digital loop carrier, and fiber optic digital loop carrier systems.

2.10 When digital loop carrier (DLC) is used to provide IBRULS, the DLC will provide an ISDN Basic Rate interface at the RDP that meets the network requirements in ANSI T1.601-1992 [1].

2.11 It is currently known that the 2B1Q line code is incompatible with a number of embedded services. These services include CO-LAN, 15 kHz Program Audio Service, and analog carrier systems.

2.12 Analog carrier systems are extremely susceptible to interference from the 2B1Q line code and separation into separate cable sheaths is required.

2.13 Program audio services are also susceptible to interference from the 2B1Q line code on the loop. In order for the program audio and the IBRULS services to coexist, binder group separation is necessary. Separation to non-adjacent binder groups is preferred but adjacent binder groups may provide adequate margin.

2.14 Data-Voice Multiplexers (DVM) are also incompatible with IBRULS depending upon the range at which the DVMs are deployed. If DVMs are operated at less than 80% of the manufacturer's maximum specified range, including CO and customer wiring, they may be compatible with the 2B1Q line code. If DVMs are operated at or above the 80% range and occupy

the same cable sheath as a 2B1Q service, then the two services are considered to be incompatible. In this case binder group separation is necessary. If this is not possible, an alternate means of providing the 2B1Q service must be sought.

2.15 IBRULS utilizes subscriber loop facilities that were originally designed for Plain Ordinary (analog) Telephone Service (POTS). For this reason, some loops, such as loaded metallic facilities or analog carrier systems, may not be suitable for IBRULS.

2.16 Bell Atlantic will work with the OTC to resolve facility problems should the IBRULS loop facility require enhancement equipment to support BRI service.

2.17 If an OTC service is provided using IBRULS and electronic transmission enhancement equipment is required to meet OTC requirements that are more stringent than IBRULS and Basic Rate ISDN, the OTC will be responsible for providing such enhancement equipment.

C. DS1 (1.544 Mbps) Unbundled Loop Service (DS1ULS)

2.18 DS1ULS provides the OTC with a 4-wire transmission channel that is suitable for the transport of 1.544 Mbps (DS1) digital signals in both directions simultaneously.

2.19 The interface at the OTC DSX-1 termination in the BA CO is 4-wire and the interface at the EU-RDP is 4-wire. The conductors of the OTC or EU transmit pair are called tip and ring and the conductors of the OTC or EU receive pair are called tip 1 and ring 1.

2.20 The transmission channel between the DS1ULS interfaces consists of 4-wire facilities. DS1ULS may be provided using a variety of loop transmission technologies, including but not limited to, metallic cable, metallic cable with regenerators, metallic cable with High-Bit-Rate Digital Subscriber Line (HDSL) technology, or fiber optic transport systems. A typical DS1ULS configuration is shown in Figure 2-2.

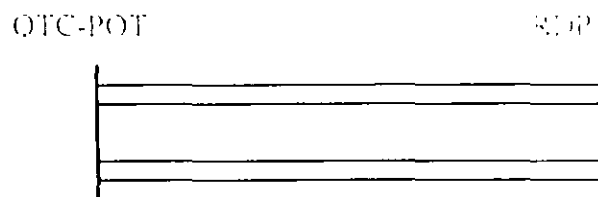

Figure 2-2: Typical 4-Wire DS1ULS configuration

2.21 DS1ULS enables full duplex 1.544 Mbps digital transmission. The 1.544 Mbps line rate supports an 8 kbps framing format and 1.536 Mbps of payload data. DS1ULS will support either the Superframe (SF) or Extended Superframe (ESF) framing formats as specified in ANSI T1.403-1995 [4].

2.22 DS1ULS is available with either the AMI or B8ZS line codes as specified in ANSI T1.403-1995 [4].

2.23 DS1ULS shall provide an electrical DS1 interface at the RDP that meets the network requirements in ANSI T1.403-1995 [4].

2.24 The DS1 interface provided by BA does not deliver direct-current power to the NI via the simplex leads of the transmit and receive pairs. When BA employs metallic facilities and no loopback device is deployed, direct-current power could appear at the NI on the simplex leads of the transmit and receive pairs however. In such cases, the OTC or EUC equipment shall provide a direct-current connection between the simplexes of the transmit and receive pairs.

2.25 Direct-current power shall not be delivered to the EUC-POT by customer equipment. In addition, customer equipment shall not apply voltages to the EUC-POT other than those described in ANSI T1.403-1995.

2.26 The OTC will be responsible for providing synchronization timing for the DS1ULS.

2.27 Subscriber loop facilities were originally designed for Plain Ordinary (analog) Telephone Service (POTS). For this reason, some loops may not be suitable for DS1ULS.

D. High-Bit-Rate Digital Subscriber Line Unbundled Loop Service (HDULS)

2.28 HDULS is under study.

E. Asymmetrical Digital Subscriber Line (ADSL) Unbundled Loop Service

2.29 ADSL Unbundled Loop Service (ADULS) is under study.

F. Service Elements

2.30 IBRULS ordinarily consists of two elements:

(1) The COTDF wire and tie cable(s) between the COTDF termination of the co-located OTC equipment and the COTDF termination of a subscriber loop; and

(2) a subscriber loop facility between the CO and the EUC-RDP. The loop is either:

(a) a metallic non-loaded facility consisting of cable and wire between the COTDF and the RDP wire with no intermediate electronics; or

(b) a metallic non-loaded facility consisting of cable and wire between the COTDF and the RDP wire with transmission enhancement equipment; or

(c) a universal digital loop carrier (DLC) facility with 2B+1D ISDN Basic Rate transport capability via three DS0 channels. The DLC facility consists of:

- CO cabling between the CODF and a DLC Central Office Terminal (COT) equipped with an ISDN Basic Rate Interface Terminal Equipment (BRITE) channel unit with NT functionality;
- a fiber or metallic facility from the DLC COT to the DLC Remote Terminal (RT) equipped with an ISDN BRITE channel unit with LT functionality; and,
- cable and wire between the DLC RT and the RDP.

2.31 DS1ULS ordinarily consist of two elements:

(1) The DSX-1 wire and repeatered tie cable(s) between the DSX-1 termination of the co-located OTC equipment and the DSX-1 termination of subscriber loop facilities; and

(2) a subscriber loop facility between the CO and the EL-RDP. The loop is either:

(a) a metallic non-loaded facility consisting of cable and wire between the CODF and the RDP wire with no intermediate electronics; or,

(b) a metallic non-loaded facility consisting of cable and wire between the CODF and the RDP wire with transmission enhancement equipment such as regenerators or DSL technology; or,

(c) a fiber facility from the CO to a Remote Terminal (RT) location with cable and wire between the DLC RT and the RDP.

2.32 HDULS is under study.

2.33 ADULS is under study.

3. Element Specifications

A. General

3.01 Two elements are always used with digital unbundled loop services. They are: CODF wire and tie cable(s), and subscriber loop facilities. A third element, electronic transmission enhancement equipment, is sometimes used with digital unbundled loop services. The following sections contain the specifications for each of these elements.

B. CODF Wiring and Tie Cable(s)

3.02 CODF cross-connect wiring and tie cable(s) are used to link the CODF termination of co-located OTC equipment to the CODF termination of metallic subscriber loops, DLC CO's, and electronic transmission enhancement equipment.

3.03 The total combined length of all CODF cross-connect wiring and all CODF-to-CODF tie cables between the CODF termination of the OTC equipment and the CODF termination of any subscriber loop in the same CO should be less than 1500 feet. No bridged tap is permitted in the CO.

3.04 The direct-current resistance between the CODF termination of the OTC equipment and the CODF termination of any subscriber loop in the same CO should be less than 80 ohms. This is equal to 1500 or less feet of 24 gauge cable.

3.05 The 1 kHz loss measured on the CODF wiring and tie cables when measured between 900 ohm impedances should be .85 dB or less.

C. Subscriber Loop Facilities

3.07 Subscriber loop facilities consist of feeder and distribution plant between the CODF and the EU customer's RDP. Feeder plant uses a variety of transmission technologies, including but not limited to, twisted-pair metallic cables, twisted-pair metallic cable based digital loop carrier, and fiber optic based digital loop carrier. Distribution plant usually consists of multipair metallic cables. Additional information about subscriber loops may be found in Bellcore SR-TSV-002275 [2].

3.08 Subscriber loop facilities have been designed on a global basis primarily to accommodate POTS and guarantee that loop transmission loss at 1 kHz is statistically distributed and that no single loop exceeds the signaling range of the CO.

3.09 Prior to 1980, loops were designed using one of the following design plans: Resistance Design (RD), Long Route Design (LRD), or Unigauge Design (UD). From 1980 to 1986, the Modified Resistance Design (MRD), Modified Long Route Design (MLRD), and Concentrated Range Extension with Gain (CREG) plans were applied on a going-forward basis (i.e., retroactive redesign was not implemented). In 1986, the Revised Resistance Design (RRD) plan was applied on a going-forward basis.

3.10 Most metallic loop facilities (98%) were designed using the RD, MRD, or RRD design rules. The RRD design rules currently in use limit the loop resistance to the design range of the CO switch (1300 or 1500 ohms) or 1500 ohms whichever is less. The vast majority of non-loaded loops, designed using these rules, will support HBRI LS without the need for additional transmission enhancement.

3.11 An IBRULS qualified metallic loop facility is non-loaded and meets the following ISDN Basic Rate design parameters:

- (1) The length shall be 18 kft or less;
- (2) The direct-current resistance measured between the CODF and the EU-RDP shall be 1300 ohms or less;
- (3) Loaded bridged-tap is not permitted;
- (4) Bridged tap is limited to 6 kft;
- (5) The 40 kHz loss of a metallic loop facility when measured with a 135 ohm impedance at the CODF and a 135 ohm impedance at the RDP shall be 49.0 dB or less;
- (6) Metallic loops with a 40 kHz loss between 40 and 76 dB will require transmission enhancement equipment.

3.12 The leakage resistance between the tip conductor and ground and the ring conductor and ground on an IBRULS metallic loop shall each be greater than 100 K ohms.

3.13 The longitudinal noise or power influence (PI) measured per ITU-T Std 743-1984 [3] on an IBRULS metallic loop should be less than 90 dBmC.

3.14 The longitudinal balance of a metallic IBRULS loop is defined as the longitudinal noise (in dBmC) minus the C-message noise (in dBmC). The longitudinal balance shall be >50 dB.

3.15 Qualification for IBRULS may require the placement of a mid-span repeater or similar device. Bell Atlantic does not place more than one mid-span repeater per loop. If a loop will not operate with one repeater, construction of DLC will be necessary.

3.16 When a metallic IBRULS loop has a mid-span repeater, the metallic facility between the CODF and the mid-span repeater and the metallic facility between the mid-span repeater and the EU-RDP shall each meet the requirements in section 3.11.

3.17 IBRULS will not operate properly on non-staggered twist cable installed prior to 1923 or on flat ribbon cables, such as those used for some CPE interconnections. Such cable may need to be replaced to accommodate IBRULS.

3.18 The HDULS loop facility is under study.

3.19 The ADULS loop facility is under study.

D. Transmission Enhancement Equipment

3.20 Transmission enhancement equipment is sometimes used with HBR/LS. Such equipment can consist of a CO span power module, a mid-span repeater, or BRI extended range system equipment.

3.21 The span power module is located in the CO and provides power to a mid-span repeater. A mid-span repeater regenerates the 2B1Q line code. The repeater has NT functionality that faces the OTC equipment and LT functionality that faces the RDP. A mid-span repeater is deployed when the calculated loss of the non-repeated loop at 40 kHz (excluding B F) is $> 40.0 < 76.0$ dB.

3.22 BRI extended range systems consist of a unit located in the CO that has NT functionality and a 2B1Q line code that faces the OTC equipment and a remote unit near the RDP that has LT functionality and delivers a 2B1Q line code to the EC customer. The CO unit uses a line code that is spectrum compatible with BA services. The line code permits operation with a remote unit that is connected via a metallic cable that could have a 40 kHz loss of up to 90 dB.

3.23 The impedance of transmission enhancement equipment shall be a nominal 135 ohms.

3.24 Transmission enhancement equipment shall provide loop current when the RDP is terminated by a direct-current resistance of 135 ohms.

4. Service Specifications

A. General

4.01 Parameters are tested at the RDP in response to trouble reports or when additional testing is purchased.

4.02 Network Channel (NC) and Network Channel Interface (NCI) codes are used for providing channel and interface information to customers. The NC/NCI code set facilitates the identification of network channel requirements and associated interface specifications for services described in tariffs.

4.03 For switched services, the NC code is an encoded representation of the channel that is provided by from the OTC Point Of Termination (POT) to the BA CO. By varying the NC code, the customer is allowed to further specify the type of service.

4.04 The NCI code is an encoded representation used to identify five interface elements located at a POT. The five elements reflect the following physical and electrical characteristics: number of physical conductors, protocol, impedance, protocol options, and transmission levels points (if applicable).

4.05 Examples of the most common NC and NCI codes are given each service described in this section. The complete set of codes may be found in SR-STS-000307[2].

4.06 Valid NCI code combinations are shown for each service described in this section. Complete NC/NCI compatibility information may be found in SR-SFS-00032313.

B. IBRULS

4.07 The overall end-to-end IBRULS service is from the CODF termination of the OTC equipment to the EU customer's RDP.

4.08 IBRULS NC code information is shown in Figure 4-1 and IBRULS NCI code combinations are shown in Figure 4-2.

4.09 IBRULS Acceptance Limits (AL) and Immediate Action Limits (IAL) are shown in Table 4-3.

Figure 4-1: IBRULS NC Codes

| NC CODE | Character 3 | Character 4 |
|---------|-------------|-------------|
| UB | - | - |

Figure 4-2: IBRULS NCI Code Combinations

| OTC-POT | EU-POT |
|-----------|--------|
| 02QC5.OOS | 02IS5 |

Figure 4-3: IBRULS Acceptance Limits (AL) and Immediate Action Limits (IAL)

| Parameter | AL | IAL |
|-----------------|---------------|---------------|
| 40 kHz loss | < 40.0 dB | < 42.0 dB |
| Resistance | < 1500 ohms | < 1500 ohms |
| Leakage | < 100 kilohms | < 100 kilohms |
| Power Influence | < 90 dB | < 90 dB |

C. DSIULS

4.10 The overall end-to-end DSIULS service is from the DSX-1 termination of the OTC equipment to the EU customer's RDP.

4.11 DSIULS NC code information is shown in Figure 4-8, and DSIULS NCI code combinations are shown in Figure 4-9.

4.12 DS1ULS performance objectives are shown in Figure 4-10 and DS1ULS test limits are shown in Figure 4-11.

4.13 Availability is a measure of the relative amount of time that a service is "usable" by the customer. Unavailability begins when the Bit Error Ratio (BER) in each second is worse than 10^3 for a period of 10 consecutive seconds. The DS1ULS objective is 99.925 percent availability in any twelve consecutive months. Availability equals the total time minus the outage time divided by the total time.

4.14 Accuracy denotes the error performance and is usually specified in terms of errored seconds (ES), or conversely, error-free seconds (EFS). EFS are the primary measure of error performance for DS1ULS. An EFS is any second that an error does not occur.

4.15 A Severely Errored Second (SES) is any one second interval that has a BER of less than (worse than) 10^4 .

Figure 4-4: DS1ULS NC Codes

| NC CODE | Character 3 | Character 4 |
|---------|------------------|--------------|
| HC | - (SF and AMI) | - |
| HC | D (ESF and AMI) | - |
| HC | E (ESF and B8ZS) | - |
| HC | Z (SF and B8ZS) | - |
| HC | E (ESF and B8ZS) | I (ISDN PRA) |

Figure 4-5: DS1ULS NCI Code Combinations

| OTC-POT | EU-POT |
|----------|-------------------------|
| 04QB9.11 | 04DU9.3N (SF and AMI) |
| 04QB9.11 | 04DU9.3N (SF and B8ZS) |
| 04QB9.11 | 04DU9.3N (ESF and AMI) |
| 04QB9.11 | 04DU9.3N (ESF and B8ZS) |

Figure 4-6: DS1ULS Performance Objectives

| Parameter | Objective |
|--------------|--|
| Accuracy | 0.25 % errored seconds long-term (30 days or more) |
| Availability | 99.925 % per year |

Figure 4-7: DS1ULS Test Limits

| Test Duration | Errored Seconds | Severely Errored Seconds |
|---------------|-----------------|--------------------------|
| 15 min | 0 | 0 |
| 30 min | 3 | 0 |
| 45 min | 5 | 2 |
| 24 hours | 150 | 7 |

4.16 Acceptance testing for DS1ULS should be performed with a Quasi Random Signal Source (QRSS), on an OTC-POT to EU-POT basis, using ES performance parameters.

4.17 If BA has installed a loopback device on the DS1ULS, a dispatch for "cooperative testing" will not ordinarily be made and testing will be performed remotely. Normally, a technician will be dispatched by BA in the following instances:

- The DS1ULS is not equipped with a loopback device;
- The loopback device is inoperable;
- Test results do not meet applicable limits;
- The OTC requests a dispatch.

4.18 At the request of the OTC, BA will provide the remote test results to the OTC.

4.19 Other tests may be performed in response to trouble reports or when additional testing is purchased. The 3/24, 1/8, and All Ones patterns are acceptable diagnostic stress tests for DS1ULS when used in accordance with Figure 4-8.

4.20 The patterns in Figure 4-8 may not detect all possible troubles. Additional tests may be required using other patterns designed to detect specific problems (e.g., bridged tap, etc.).

4.21 If errors are detected using the QRSS, 3/24, or 1/8 patterns, it is recommended that the DS1ULS line code options (AMI B8ZS) be verified using the procedures outlined in the Bell Atlantic Network Services Reference Manual Series 72710 & NS0050. These tests make use of the Framed 2/8 and Framed 1/8 patterns.

Figure 4-8: AMI and B8ZS Test Matrix (1)

| TEST PATTERN (2) | TEST DURATION | ACCEPTANCE LIMIT | MAINTENANCE LIMIT |
|-------------------------------------|---------------|------------------|-------------------|
| 3/24 (AMI only) | 5 minutes | 7 | 60 |
| 1/8 (B8ZS only) | 5 minutes | 7 | 60 |
| All Ones | 5 minutes | 7 | 60 |
| QRSS | 15 minutes | 20 | 60 |
| Framed All Zeros (3) (B8ZS only) | 30 seconds | 0 | 0 |

Notes:

(1) Test patterns should be framed.

(2) If compatible test equipment is not available to perform these tests, loopback testing should be utilized.

(3) WARNING: This pattern may cause DS1 failures if DS3 equipment is not optioned properly.

D. HDULS

4.22 HDULS service is under study.

E. ADULS

4.25 ADULS service is under study.

5. OTC Equipment and CO Cabling Requirements

A. OTC Equipment Requirements

5.01 Co-located OTC equipment used for interconnection with digital unbundled loop services shall meet all of the applicable generic equipment requirements in Bellcore GR-63-CORE [4] and Bellecore GR-1089-CORE [5].

5.02 Co-located OTC equipment used for interconnection with digital unbundled loop services shall be manufactured in accordance with FCC, NEC, UL, and USDI requirements and orders applicable to Federal, State, and local requirements including, but not limited to, statutes, rules, regulations, orders, or ordinances, or otherwise imposed by law. Requirements that are not specified in this document, contractual technical requirements, or other applicable documents, shall meet the manufacturer's requirements consistent with industry standards.

- 5.03** The open circuit tip-to-ring dc voltage that co-located OTC equipment applies to BA VF cabling shall be less than 80 Vdc.
- 5.04** Co-located OTC equipment shall not deliver more than 2.5 watts of power to any load via BA VF cable.
- 5.05** Co-located OTC equipment shall not deliver more than 150 mA of loop current to any load via BA VF cable.
- 5.06** The noise limits for digital unbundled loop services require co-located OTC equipment to have a longitudinal balance of >60 dB.
- 5.07** The loss and noise limits for IBRLS requires co-located OTC equipment to have a nominal impedance of 135 ohms.
- 5.08** The maximum power level of any transmitted signal on IBRLS shall not exceed ANSI T1.601-1992 [1].
- 5.09** OTC equipment used with Digital Unbundled Loop Services shall be synchronized to a stratum 1 clock.
- 5.10** Loops may be exposed to electrical surges from lightning and commercial power system disturbances. Despite protective devices on the CORD, some of these disturbances are likely to reach OTC equipment. OTC equipment shall be designed to withstand certain surges without being damaged, and shall fail in a safe manner under infrequent high stress.
- 5.11** The prevalent voltage-limiting device available for CO use is the 3-mil carbon block. This device has an upper 3c limiting voltage of 1000 volts peak under surge conditions and 600 volts rms (800 peak) at 60 Hz. OTC equipment connected to digital unbundled loop services with loops protected by carbon blocks may be subjected to voltages up to these levels. Unexposed COs may not have primary protection, and OTC equipment not coordinating with carbon blocks may need protection in these locations.
- 5.12** If the subscriber loop facility is exposed to commercial ac power, the CO protector may also include 350 mA heat coils for limiting the current that is permitted to flow to CO equipment. In addition, a protective fuse cable located outside the CO incorporating 24 or 26 AWG conductors to coordinate with the protector, serves to limit current to safe levels in the event of prolonged operation of the protector during power fault conditions.

B. OTC Equipment CO Cabling Requirements

- 5.13** The CO cabling used to terminate OTC equipment on the CORD shall use twisted-pair conductors.

5.14 The type, gauge, and length of the OTC CODF cabling shall be specified based on this specification and OTC equipment requirements. If the specifications in this document differ from the OTC equipment manufacturers specifications, then the more stringent of the two shall be used.

5.15 The direct-current resistance of the CO cabling between the OTC equipment and the CODF shall meet the CO cabling requirements in the Bellecore FR-TSY-000064 [6] (i.e., 23 ohms or less). This is equivalent to 275 feet or less of 26 gauge cable, 440 feet or less of 24 gauge cable, and 700 feet or less of 22 gauge cable.

5.16 All CO cabling between OTC equipment and the CODF shall be connected as specified by the BA CO Engineer.

5.17 The 1kHz loss of the CO cabling between the OTC equipment and the CODF, when measured between 900 ohm impedances, shall be less than .15 dB.

5.18 The C-message noise measured on the CO cabling between the OTC equipment and the CODF shall be 20 dBmC or less.

6. References

A. Definitions

Asymmetrical Digital Subscriber Line (ADSL)

A system that is capable of transmitting digital signals up to 6 Mbps toward the EU-POT and up to 640 kbps from the EU-POT.

ADSL Unbundled Loop Service (ADULS)

A service that provides an effective 2-wire channel, suitable for the transport of ADSL that uses Carrierless AM-PM (CAP) technology, between the Bell Atlantic central office distributing frame termination of co-located equipment belonging to an OTC and the rate demarcation point at a customer location.

Basic Rate Integrated Services Digital Network Interface (BRI)

The BRI is a 2-wire ISDN interface that uses the two-binary one-quaternary line code at a 160 kilobit per second rate to transport overhead and up to two B channels and one D channel.

B Channel

The B channel is a 64 kilobit per second channel used for information transfer between users.

Bridged tap

Any branch section of a cable pair, or any extension of a cable pair beyond the point where it is used, in which no direct current flows when customer equipment is connected and used.

Central Office (CO)

A telephone company building which houses equipment and facilities used to provide switched access services.

Central Office Distributing Frame (CODF)

Framework located in a CO that holds wire cross-connects which are used to interconnect cable terminations for EU customer loops, switching system ports, and inter-office facilities.

Channel

An electrical, or photonic communications path between two or more points of transmission.

C-Message Noise

The frequency-weighted, short-term average noise within an idle channel. The frequency weighting, called C-message, is used to account for the variations in 500-type telephone set transducer efficiency and EU annoyance to tones as a function of frequency.

dBm

A unit for expression of power level in decibels relative to one milliwatt.

dBm

A unit used to express noise power in decibels relative to one picowatt (-90 dBm).

dBm0

A unit used to express power level in decibels relative to one milliwatt referred to, or measured at, a zero transmission level point (OTLP). A unit used to express noise power in decibels relative to one picowatt measured with C-message weighting.

dBmC0

Noise power in dBmC referred to, or measured at, a zero transmission level point (OTLP).

D Channel

The D Channel is a 16 kilobit per second packet-switched channel that carries signaling and control for the B channels and also supports customer packet data traffic at speeds up to 9.6 kilobits per second.

Decibel (dB)

The logarithmic unit of signal power ratio most commonly used in telephony. It is used to express the relationship between two signal powers, usually between two acoustic, electric, or optical signals; it is equal to ten times the common logarithm of the ratio of the two signal powers.

Digital Signal Level One (DS1)

A digital signal transmitted at the nominal rate of 1.544 Mbit/s.

Facilities

Any cable, poles, conduit, microwave, or carrier equipment, central office distributing frames, central office switching equipment, computers (both hardware and software), business machines, etc., utilized to provide the services offered by a telephone company.

High-Bit-Rate Digital Subscriber Line (HDSL)

A system that is capable of transmitting bi-directional DS1 (1.544 Mbps) signals or bi-directional half DS1 (768 kbps) signals over metallic twisted-pair cables to provide access to digital telecommunications services.

HDSL Unbundled Loop Service (HDULS)

A service that provides a 2-wire or 4-wire metallic channel, suitable for the transport of HDSL, between the Bell Atlantic central office distributing frame termination of co-located equipment belonging to an OTC and the rate demarcation point at a customer location.

Integrated Services Digital Network (ISDN)

ISDN describes the end-to-end digital telecommunications network architecture which provides for the simultaneous access, transmission, and switching of voice, data, and image services. These functions are provided via channelized transport facilities over a limited number of standard user-network interfaces.

ISDN Basic Rate Unbundled Loop Service (IBRULS)

An unbundled loop service that provides an ISDN basic rate channel between the Bell Atlantic central office distributing frame termination of co-located equipment belonging to an OTC and the rate demarcation point at a customer location.

Leakage

The resistance between the conductors of an insulated metallic pair or the resistance between each conductor of an insulated metallic pair and ground.

Loop

A transmission channel between a customer location and a BA CO that is used as a transmission channel for telephone company services.

Other Telephone Company (OTC)

An organization that provides telecommunications services to the public.

Plain Ordinary Telephone Service (POTS)

The basic single line switched access service offered by local exchange carriers to residential and business customers. POTS uses loop-start signaling.

Power Influence (PI)

The power of a longitudinal signal induced in a metallic loop by an electromagnetic field emanating from a conductor or conductors of a power system. PI is also called longitudinal noise or noise-to-ground.

Rate Demarcation Point (RDP)

The point at which Bell Atlantic network access recurring charges and responsibility stop and beyond which customer responsibility begins. The RDP is the point of demarcation and/or interconnection between a Bell Atlantic subscriber loop facility and EU premises cabling or terminal equipment. Bell Atlantic facilities at, or constituting, the rate demarcation point shall consist of wire or a jack conforming to Subpart F of Part 68 of FCC rules.

Transmission Enhancement Equipment

In general, any equipment that improves the characteristics of a transmitted signal. In this document, transmission enhancement equipment is any equipment that regenerates a digital signal.

Unbundled Loop

A transmission channel between a EU customer location and a LEC CO that is not a part of, or connected to, other LEC services.

Voice Grade (VG)

A term used to describe a channel, circuit, facility, or service that is suitable for the transmission of speech, digital or analog data, or facsimile, generally with a frequency range of about 300 to 3000 Hz.

B. Acronyms

| | |
|--------|--|
| ADSL | Asymmetrical Digital Subscriber Line |
| ADULS | ADSL Unbundled Loop Service |
| ANSI | American National Standards Institute |
| BA | Bell Atlantic |
| BRI | Basic Rate Interface |
| BRITE | Basic Rate Interface Terminal Equipment |
| CO | Central Office |
| CODF | Central Office Distributing Frame |
| COT | Central Office Terminal |
| DLC | Digital Loop Carrier |
| DS0 | Digital Signal Level Zero |
| DS1 | Digital Signal Level One |
| DVM | Data-Voice Multiplexer |
| HDSL | High-Bit-Rate Digital Subscriber Line |
| HDULS | High-Bit-Rate Digital Unbundled Loop Service |
| IBRULS | ISDN Basic Rate Unbundled Loop Service |
| ISDN | Integrated Services Digital Network |
| LT | Line Terminating |
| NT | Network Terminating |
| OTC | Other Telephone Company |
| PI | Power Influence |
| POTS | Plain Ordinary Telephone Service |

| | |
|------|------------------------------|
| RD | Resistance Design |
| RDP | Rate Demarcation Point |
| RT | Remote Terminal |
| USOC | Universal Service Order Code |
| VF | Voice Frequency |
| VG | Voice Grade |
| 2BIQ | Two-Bit One-Quaternary |

7. Bibliography

- 1- ANSI T1.601-1992, American National Standard for Telecommunications- ISDN - Basic Access Interface for Use on Metallic Loops for Application at the Network Side of NT, Layer 1 Specification.
- 2- Special Report SR-TSV-000307
- 3- Special Report SR-TSV-000323
- 3- IEEE Std 743-1984, IEEE Standard Methods and Equipment for Measuring the Transmission Characteristics of Analog Voice frequency Circuits.
- 4- Generic Requirements GR-63-CORE, Network Equipment-Building System (NEBS) Requirements: Physical Protection, Issue 1, (Bellcore, October 1995).
- 5- Generic Requirements GR-1089-CORE, Electromagnetic Compatibility and Electrical Safety - Generic Criteria for Network Telecommunications Equipment, Issue 1 (Bellcore, November 1994).
- 6- Technical Reference FR-NWT-000064, LATA Switching Systems Generic Requirements (LSSGR), (Bellcore, 1994).
- 7- Committee T1 Technical Report No.28, *High-Bit-Rate Digital Subscriber Line (HDSL)*, February, 1994.

NOTE: These documents are subject to change; references reflect the most current information available at the time of printing. Readers are advised to check the status and availability of all documents.

EXHIBIT D

EXHIBIT D

Specialized Routing Solution For Operator & DA Calls

| CALL TYPE | SESS | DMS-100 | EWSD | IAESS | DMS-10 |
|-------------------|-------------------------------------|-------------------------------------|-------------------------------------|-------------------------------------|-------------------------------------|
| 0- | AIN | AIN | AIN | SRN | SRN |
| 01 local | LCC (cocot coin) | LCC (cocot coin) | LCC (cocot coin) | LCC (cocot coin) | LCC (cocot coin) |
| | SRN (non-coin) | SRN (non-coin) | SRN (non-coin) | SRN (non-coin) | SRN (non-coin) |
| 03 Intra-ATA toll | LCC (coin) | LCC (coin) | LCC (coin) | LCC (coin) | LCC (coin) |
| | SRN/2PIC ¹ (non-coin) | SRN/2PIC ¹ (non-coin) | SRN/2PIC ¹ (non-coin) | SRN/2PIC ¹ (non-coin) | SRN/2PIC ¹ (non-coin) |
| 411 | AIN | AIN | AIN | AIN | SRN |
| 555-1212 | AIN | AIN | AIN | AIN | SRN |

¹After 2PIC implementation, these calls will be routed to the Intra-ATA toll provider.

Definitions:

1. AIN - Advanced Intelligent Network
2. SRN - Specialized Routing Node
3. LCC - Line Class Code

EXHIBIT E

EXHIBIT E

AIN EXCEPTION LIST

| Lucent 5ESS | Nortel DMS100 | Siemens EWSD |
|------------------------------------|--|----------------------------|
| ISATND # ISDN Attendant Lines | NISDN - BRI, Including EKTS | Two-Party Lines |
| DID Lines without Office Equipment | MDC Attendant Consoles Data Units | Denied Origination Service |
| CustoPak Lines | MBS Data Units, Customized ISDN Lines, and functional signaling Meridian feature transparency (MFT) set. (P-phones) | Remote Call Forwarding |
| Customized ISDN Lines | Datapath lines | |
| | WATS lines | |

OTHER AIN-BASED SERVICE EXCEPTIONS

1. CENTREX ARS
2. Easy Voice
3. Work At Home Billing Service
4. CENTREX Extend
5. Switch Redirect Service (requires special handling)

EXHIBIT F

EXHIBIT F

TR 72580
Issue 1, January 1997

Bell Atlantic Technical Reference

**Analog Unbundled Port Services
Technical Specifications**

© 1997 Bell Atlantic Network Services, Inc.
All Rights Reserved
Printed in U.S.A.

Bell Atlantic Network Services, Inc.
Technical Reference

TR 72580
Issue I, January 1997

Notice

This Technical Reference is published by Bell Atlantic to provide a technical description of Analog Unbundled Port Services. To the extent feasible, the description references or duplicates existing published technical references utilized by the industry.

Bell Atlantic reserves the right to revise this technical reference for any reason including, but not limited to, changes in tariffs, laws, or regulations, conformity with updates and changes in standards promulgated by various agencies, utilization of advances in the state of technical arts, or the reflection of changes in the design of any facilities, equipment, techniques, or procedures described or referred to herein. Liability for difficulties arising from technical limitations or changes herein is disclaimed.

Bell Atlantic reserves the right not to offer any or all of these services and to withdraw any or all of them at any future time. In addition, the services described herein are based on available facilities and equipment and may not be universally available.

With respect to services offered pursuant to tariff, however, the terms and conditions of the service offering are determined by the tariff itself and applicable laws and regulations. This reference is intended to be supplemental to the tariffs. In the event of a conflict between the tariffs, laws or regulations and this reference, the tariffs, laws, and regulations shall govern.

For additional copies, please contact:

Bell Atlantic Document and Information Delivery Services
1310 N. Court House Road
Arlington, VA 22201
703-974-5887

For information about the technical specifications in this TR, contact:

Trone Bishop
1 East Pratt St.
Baltimore, Md. 21202
410-736-7622

EXHIBIT F

Bell Atlantic Network Services, Inc.
Technical Reference

TR 72580
Issue 1, January 1997

Bell Atlantic Technical Reference
Analog Unbundled Port Services
Technical Specifications

| Contents | Page |
|---|-------------|
| 1. General | 1 |
| 2. Service Description | 1 |
| 3. Service Elements | 6 |
| A. General | 6 |
| B. CODF Wiring and Tie Cable(s) | 6 |
| C. Bell Atlantic Local Switching System CO Cabling | 6 |
| D. Local Switching System Analog Ports | 7 |
| 4. Service Specifications | 7 |
| 5. OTC Equipment and CO Cabling Requirements | 8 |
| A. OTC Equipment Requirements | 8 |
| B. OTC CO Cabling Requirements | 9 |
| 6. References | 10 |
| A. Definitions | 10 |
| B. Acronyms | 12 |
| 7. Bibliography | 13 |

| Figures | Page |
|--|-------------|
| Figure 2-1: Typical Analog Unbundled Port Configuration | 2 |
| Figure 2-2: Unbundled Port Service Elements | 3 |
| Figure 2-3: Requirements Associated with Analog Unbundled Port Services | 4 |
| Figure 2-4: UPS NC Codes | 5 |
| Figure 2-5: UPS NCI Codes | 5 |
| Figure 2-6: Valid Analog UPS NC NCI Code Combinations | 5 |
| Figure 4-1: Analog UPS Acceptance Limits (AL) and Immediate Action Limits (IAL) | 7 |
| Figure 4-2: Compatible TLP Ranges at the OTC-POT | 8 |
| Figure 4-3: Compatible TLP Ranges at the BA Local Switching System | 8 |

1. General

1.01 This technical reference provides the technical specifications associated with the Analog Unbundled Port Services offered by Bell Atlantic in the co-carrier section of some local exchange tariffs.

1.02 Whenever this technical reference is reissued, the reason(s) for reissue will be provided in this paragraph.

1.03 Analog Unbundled Port Services (UPS) enable Other Telephone Companies (OTC) that are collocated in a Bell Atlantic (BA) Central Office (CO) to connect to analog switch ports on BA local switching systems. The analog switch ports provide access to the functionality of the switch including supervisory signaling, digit reception and transmission, routing, rating, usage, as well as other line or trunk features.

1.04 The technical specifications in this document assume that the OTC is collocated in the same CO as the analog UPS. In the future, BA may offer transport services for analog UPS. In that case, the technical specifications associated with the transport service will supersede those in this document where applicable.

2. Service Description

2.01 The service description, terms and conditions, prices, and Universal Service Order Codes (USOCs) for analog UPS are contained in applicable tariffs or contracts.

2.02 Analog UPS are provided subject to availability on a first-come first-served basis. Special construction charges apply when appropriate facilities are not available.

2.03 Analog UPS vary according to the type of switch port (interface) and the services desired. This document contains the technical specifications associated with the analog switch port. The services associated with the analog switch port are described in applicable tariffs and other technical references.

2.04 Analog ports provide a local switch interface that is suitable for the transmission of analog voice grade signals between approximately 300 and 3000 Hz. Analog ports use various methods of dc supervisory signaling to control call processing.

2.05 The following analog UPS are offered: Basic, Centrex, PBX, and Direct Inward Dialing (DID). The Basic, Centrex, and PBX ports are on the line side of the local switching system and use Loop-Start or Ground-Start signaling. The DID port is on the trunk side of the local switching system and uses Loop Reverse-Battery signaling.

2.06 Basic, Centrex, PBX, and DID ports consist of a 2-wire analog interface associated with a local switching system and a 2-wire CODF cross-connect between a 2-wire OTC CODF

termination and the CODF termination of the analog port. At each 2-wire interface one conductor is called tip and the other conductor is called ring. A typical analog port configuration is shown in Figure 2-1.

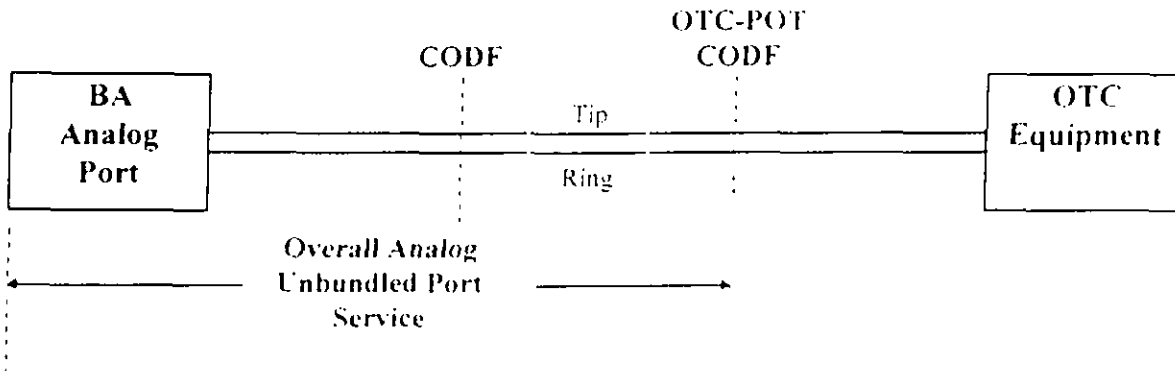

Figure 2-1. Typical Analog Unbundled Port Configuration

2.07 An analog UPS ordinarily consists of the following elements (see Figure 2-2):

- (1) Central Office Distributing Frame (CODF) wire and tie cables between the CODF termination of the OTC equipment and the CODF termination of the BA analog switch port;
- (2) CO cabling between the CODF and the BA analog switch port; and,
- (3) an analog switch port on a BA local switching system that is either:
 - (a) a loop-start line-side port (LSLS);
 - (b) a ground-start line-side port (GSLS); or,
 - (c) a loop reverse-battery trunk-side port (LRTS). The LRTS port is either:
 - (i) an LRTS port on the trunk-side of a local switching system; or,
 - (ii) an LRTS port on a digital channel bank in the same building that has a high capacity connection (such as DS1) to a local switching system.
- (4) Each LSLS or GSLS port has the following basic characteristics and capabilities:
 - (a) an associated telephone number;
 - (b) Dial Pulse (DP) or Dual Tone Multi-Frequency (DTMF) address signaling;
 - (c) access to local calling within the minimum BA-defined local calling area for each rate center;
 - (d) basic intercept;
 - (e) one primary directory listing;
 - (f) PIC1 and PIC2 access;

- (g) access to 911;
- (h) access to call routing, switch usage, and recording capability.

(5) Each LRTS port has the following basic characteristics and capabilities:

- (a) one way call routing from the BA local switching system to the OTC for associated telephone numbers;
- (b) DP, DTMF, or MF address signaling;
- (c) access to call routing and switch usage capabilities.

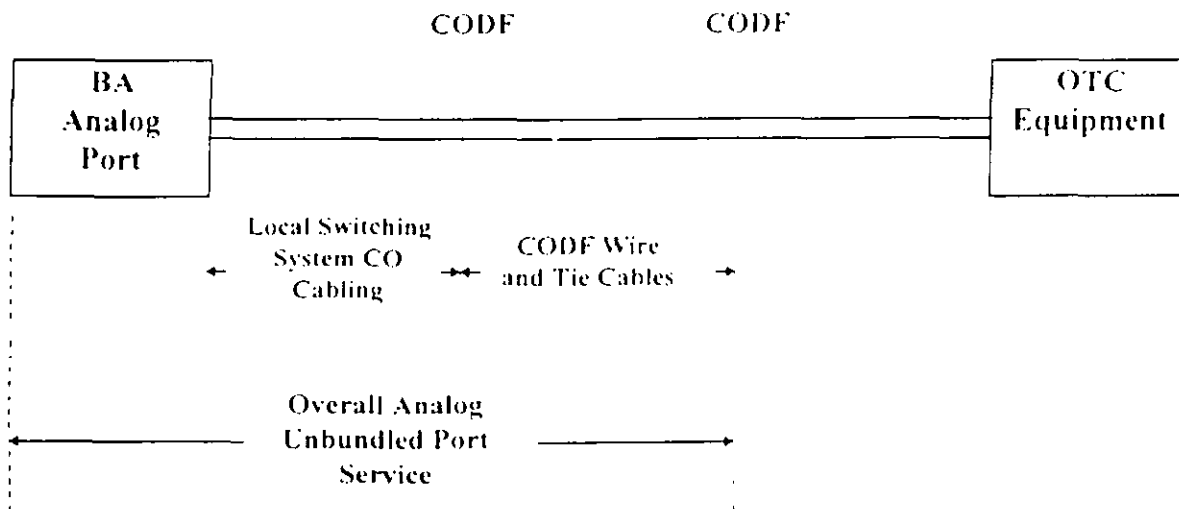

Figure 2-2. Unbundled Port Service Elements

2.08 The requirements for the BA unbundled port service elements are provided in Section 3 of this technical reference. The overall service requirements are specified in Section 4. Section 5 provides OTC equipment and cabling specifications. Figure 2-3 shows the requirements associated with unbundled port services.

2.09 The Basic line-side port is suitable for single line residential or business service. Unless the OTC requests ground-start supervisory signaling or DP address signaling at the time the service is ordered, the Basic port will be provided with loop-start supervisory signaling and DTMF address signaling capabilities. DP address signaling can be used on a port that is arranged for DTMF signaling.

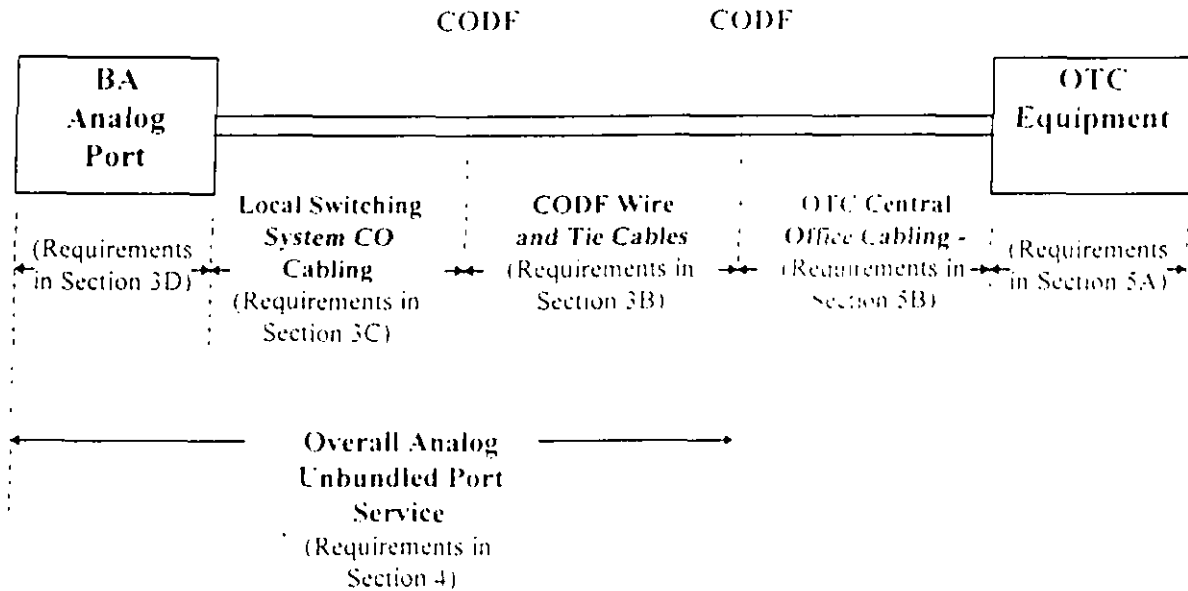

Figure 2-3: Requirements Associated with Analog Unbundled Port Services

2.10 The Centrex port is suitable for Centrex line service. Unless the OTC requests ground-start supervisory signaling or DP address signaling at the time the port is ordered, the Centrex port will be provided with loop-start supervisory signaling and DTMF address signaling capabilities. DP address signaling can be used on a port that is arranged for DTMF signaling.

2.11 The PBX port is suitable for Private Branch Exchange (PBX) Central Office trunks. Unless the OTC requests loop-start supervisory signaling or DP address signaling at the time the port is ordered, the PBX port will be provided with ground-start supervisory signaling and DTMF address signaling. DP address signaling can be used on a port that is arranged for DTMF signaling.

2.12 The DID port is suitable for one-way Direct Inward Dialing (DID) trunks. Loop reverse battery is the only supervisory signaling available. Unless the OTC requests DTMF or MF address signaling at the time the port is ordered, the DID port will be provided with DP address signaling.

2.13 The following list of supplementary features are some of the features that are available on line-side ports where technically feasible. Detailed feature lists by switch port type will be provided by the product manager.

- Additional listings
- Operator services
- Directory assistance
- Call Blocking (customer or OTC activated)
- Caller ID (calling number delivery)
- Speed calling

- 3-Way calling
- Call Waiting
- Call Forwarding (including Call Forwarding Busy and No Answer)
- Early fraud warning
- Hunt group arrangements
- Usage recording and daily usage tapes indicating the to and from number and start and stop time by port
- Simplified Message Desk Interface data link
- Routing options

2.14 All analog UPS services use the SN network channel (NC) code. Additional NC option codes are shown in Figure 2-4.

2.15 Network Channel Interface (NCI) codes describe the type of DTC signaling. Valid analog NCI codes are shown in Figure 2-5.

2.16 Valid analog NC/NCI code combinations are shown in Figure 2-6.

Figure 2-4: UPS NC Codes

| NC Code | Character 3 | Character 4 |
|---------|-------------|---|
| SN | A (2-wire) | L (line-side port) T (trunk-side port) |

Figure 2-5: UPS NCI Codes (see note)

| NCI Code | Description |
|-----------|--|
| 02QC3.OOE | Loop-start signaling - Closed End |
| 02QC3.OOC | Ground-start signaling - Closed End |
| 02QC3.RVT | Loop Reverse-battery Terminating Signaling |

Note: NCI codes describe the function performed by the connecting DTC equipment, not the function of the unbundled port service. For example, an LSLS port performs the open end function of an LSL line and connecting DTC equipment performs the closed end function.

Figure 2-6: Valid analog UPS NC/NCI Code Combinations

| Unbundled Port Service | NC Code | NCI Code |
|------------------------|---------|-----------|
| LSLS | SNAL | 02QC3.OOE |
| GSLS | SNAL | 02QC3.OOC |
| LRTS | SNAT | 02QC3.RVT |

3. Service Elements

A. General

3.01 Three elements are always used with analog Unbundled Port Services. They are: Central Office Distributing Frame (CODF) wire and tie cable(s), BA local switching system CO cabling, and a BA local switching system port. The following sections contain the specifications for each of these elements.

B. CODF Wiring and Tie Cable(s)

3.02 CODF cross-connect wiring and tie cable(s) are used to link the CODF termination of OTC equipment to the CODF termination of the BA local switching system port.

3.03 The total combined length of all CODF cross-connect wiring and all CODF-to-CODF tie cables used for analog LPS should be less than 1500 feet.

3.04 The direct-current resistance of the CODF wiring and tie cable used for analog LPS should be less than 80 ohms. This is equal to 1500 or less feet of 24 gauge cable.

3.05 The 1kHz loss of the CODF wiring and tie cable used for LPS, when measured between 900 ohm impedances, should be less than .5 dB.

3.06 The C-message noise measured on the CODF wiring and tie cables used for analog LPS shall be 20 dBmC or less when measured between 900 ohm impedances.

C. Bell Atlantic Local Switching System CO Cabling

3.07 The voice grade CO cabling used to terminate BA Local Switching System ports on the CODF shall use twisted-pair conductors.

3.08 The type, gauge, and length of the BA CODF cabling shall be specified based on this specification and BA equipment vendor requirements. If the specifications in this document differ from the equipment manufacturers specifications, then the more stringent of the two shall be used.

3.09 The direct-current resistance of the CO cabling between the BA local switching system port and the CODF shall meet the CO cabling requirements in the Bellcore ER-TSY-000064 [1] (i.e., 23 ohms or less). This is equivalent to 275 feet or less of 26 gauge cable, 440 feet or less of 24 gauge cable, and 700 feet or less of 22 gauge cable.

3.10 The 1kHz loss of the CO cabling between the BA local switching system port and the CODF, when measured between 900 ohm impedances, shall be less than .5 dB.

3.11 The C-message noise measured on the CO cabling between the BA local switching system port and the CODF shall be 20 dBmC or less.

D. Local Switching System Analog Ports

3.12 Bell Atlantic currently offers three different local switching system analog ports. They are: (1) the loop-start line-side (LSLS) port, (2) the ground-start line-side (GSL S) port, and (3) the loop reverse-battery terminating (LRTS) trunk-side port.

3.13 The impedance of the local switching system analog port is based on the type of local switching system. Most BA local switching system ports have a nominal 900 ohms + 2.16uF impedance, however some switching system ports have a nominal impedance of 800 ohms in parallel with 0.05 uF and 100 ohms.

3.14 Line-side analog ports shall provide 20 mA or more of loop current when terminated by a direct-current resistance of between 430 ohms and 1730 ohms.

3.15 The C-message noise measured on the analog port shall be 20 dBmC or less.

3.16 The C-Notched noise measured on the analog port shall be 45 dBmC or less with a -13 dBm0 1004 Hz holding tone.

3.17 Signaling on the LSLS (02QC3.OOE) and GSL S (02QC3.OOC) ports shall conform to the network specifications in ANSI T1.401-1993 [2].

3.18 Signaling on the LRTS (02QC3.RVT) port shall conform to the network specifications in ANSI T1.405-1996 [3].

4. Service Specifications

4.01 The overall end-to-end analog UPS service is from the CDDF termination of the OTC equipment (OTC-POT) to the BA local switching system port (See Figure 2-1).

4.02 Analog UPS should meet the limits in Figure 4-1, 4-2, and 4-3 when measured at the BA local switching system test position. Parameters are usually tested in response to trouble reports or when additional testing is purchased.

Figure 4-1: Analog UPS Acceptance Limits (AL) and Immediate Action Limits (IAL)

| Parameter | AL | IAL |
|---------------------------|------------|------------|
| Loss | < 1.0 dB | > 1.5 dB |
| Resistance | < 100 ohms | > 100 ohms |
| C-Message Noise | < 30 dBmC0 | > 30 dBmC0 |
| LSLS & GSL S Loop Current | > 20 mA | < 20 mA |

4.03 Signaling on the LSLS (02QC3.OOE) and GSLS (02QC3.OOC) ports shall conform to the network specifications in ANSI T1.401-1993 [2]. Signaling on the LRTS (02QC3.RVT) port shall conform to the network specifications in ANSI T1.405-1996 [3].

4.04 Compatible TLP ranges are shown in Figures 4-2 and 4-3.

Figure 4-2: Compatible TLP Ranges at the OTC-POT

| Specified NCI Code | OTC Transmit TLP | OTC Receive TLP ^{1,2} |
|----------------------|-------------------|--------------------------------|
| 02QC3.OOE, 02QC3.OOC | 0.0 to -8.0 [0.0] | 0.0 to -1.0 |
| 02QC3.RVT | -2 to -3.5 [-3.5] | 0.0 to -1.0 |

Figure 4-3: Compatible TLP Ranges at the BA Local Switching System

| Specified NCI Code | BA Transmit TLP | BA Receive TLP |
|----------------------|-----------------|-----------------------|
| 02QC3.OOE, 02QC3.OOC | 0.0 | 0.0 to -8.0 |
| 02QC3.RVT | 0.0 | -2 to -4 ³ |

5. OTC Equipment and CO Cabling Requirements

A. OTC Equipment Requirements

5.01 Collocated OTC equipment used for interconnection with analog UPS shall meet all of the applicable generic equipment requirements in GR-63-CORE [4] and GR-1089-CORE [5].

5.02 Collocated OTC equipment shall be manufactured in accordance with FCC, NEC, UL, and USDL requirements and orders applicable to Federal, State, and local requirements including, but not limited to, statutes, rules, regulations, orders, or ordinances, or otherwise imposed by law. Where requirements are not specified in this document, contractual, technical requirements, or other applicable documents, the manufacturer's requirements consistent with industry standards shall be met.

¹ The OTC transmit TLP is normally specified by the OTC. When the OTC transmit TLP is not specified, the bracketed [] value denotes the default TLP.

² The OTC receive TLP will be a function of the BA transmit TLP (0.0) and the total loss of the BA port, BA CO cabling, and BA CORD wiring. The average OTC receive TLP is -0.5 dBm and the level cannot be adjusted.

³ When the LRTS port is an analog trunk circuit, the BA receive TLP will be a function of the OTC transmit TLP and the total loss of the BA CO cabling, the BA CORD wiring, and the BA LRTS port. The average total loss of the BA CO cabling, BA CORD wiring, and BA port is about 0.5 dB and the BA receive TLP cannot be adjusted by BA. When the LRTS port is on a channel bank that has a high capacity connection to the BA Local Switching System, the BA receive TLP is obtained by Local Switching System translations and is always -4.0.

5.03 The open circuit tip-to-ring dc voltage that collocated OTC equipment applies to BA VF cabling shall be less than 80 Vdc.

5.04 Collocated OTC equipment shall not deliver more than 2.5 watts of power to any load via BA VF cable.

5.05 Collocated OTC load equipment shall not draw more than 100 mA of loop current from LSLS and GSTS ports and shall not deliver more than 100mA of loop current to any LRTS port.

5.06 The noise limits for analog UPS are predicated on the OTC equipment having a longitudinal balance of > 60 dB when measured using the methods and equipment specified in ANSI/IEEE 455-1984 [6].

5.07 The loss and noise limits for analog UPS are predicated on collocated OTC equipment having a nominal impedance of 900 ohms when measured using the methods and equipment in ANSI/IEEE 743-1995 [7].

5.08 The applied power level of any transmitted signal averaged over 3 seconds shall not exceed -12 dBm0.

5.09 The signaling characteristics of OTC equipment associated with LSLS and GSTS ports shall conform to the loop-start and ground-start customer installation specifications in ANSI T1.401-, 1993 [2].

5.10 The signaling characteristics of OTC equipment associated with LRTS ports shall conform to the loop reverse battery customer installation specifications in ANSI T1.405-1996 [3].

B. OTC CO Cabling Requirements

5.11 The voice grade CO cabling used to terminate OTC equipment on the CODB for interconnection with analog UPS shall use twisted-pair conductors.

5.12 The type, gauge, and length of the OTC CODB cabling shall be specified based on this specification and OTC equipment requirements. If the specifications in this document differ from the OTC equipment manufacturers specifications, then the more stringent of the two shall be used.

5.13 The direct-current resistance of the CO cabling between the OTC equipment and the CODB shall meet the CO cabling requirements in the Bellcore FR-TSY-000064 [1] (i.e., 23 ohms or less). This is equivalent to 275 feet or less of 26 gauge cable, 440 feet or less of 24 gauge cable, and 700 feet or less of 22 gauge cable.

5.14 All CO cabling between OTC equipment and the CODB shall be equipped with connectors at each end. The type of connectors shall be specified by the CO Engineer.

5.15 The 1kHz loss of the CO cabling between the OTC equipment and the CODF, when measured between 900 ohm impedances using the methods and equipment specified in ANSI/IEEE 743-1995 [7], shall be less than .15 dB.

5.16 The C-message noise measured on the CO cabling between the OTC equipment and the CODF, when measured between 900 ohm impedances using the methods and equipment specified in ANSI/IEEE 743-1995 [7], shall be 20 dBmC or less.

6. References

A. Definitions

Central Office (CO)

A telephone company building which houses equipment and facilities used to provide switched access services.

Central Office Distributing Frame (CODF)

Framework located in a CO that holds wire cross-connections which are used to interconnect cable terminations for end-user customer loops, switching system ports, and inter-office facilities.

Closed end

The closed end of an access line is the end of the access line that is not switched. The closed end connects to CPE or OTC equipment that functions as terminal equipment.

C-Message Noise

The frequency-weighted, short-term average noise within an idle channel. The frequency weighting, called C-message, is used to account for the variations in 500-type telephone set transducer efficiency and end-user annoyance to tones as a function of frequency.

C-Notched Noise

The C-message frequency-weighted noise on a channel with a holding tone that is removed at the measuring end through a notch (very narrow band) filter.

dBm

A unit for expression of power level in decibels relative to one milliwatt.

dBm0

Power level referred to, or measured at, a zero transmission level point (OTLP).

dBmC

A unit used to express noise power relative to one picowatt (-90 dBm).

dBmC

Noise power measured with C-message weighting expressed in dBm.

dBmC

Noise power in dBmC referred to, or measured at, a zero transmission level point (OTLP).

Decibel (dB)

The logarithmic unit of signal power ratio most commonly used in telephony. It is used to express the relationship between two signal powers, usually between two acoustic, electric, or optical signals; it is equal to ten times the common logarithm of the ratio of the two signal powers.

Dial Pulse (DP)

A type of switched access line address signaling that uses rapid loop open and loop closure signals (pulses) to indicate the digit being dialed. The digits 1 through 9 are represented by the same number of pulses and the digit zero is represented by ten pulses.

Dual Tone Multi-Frequency (DTMF)

A type of switched access line address signaling that uses two tones transmitted simultaneously to indicate a digit (0 to 9) or character (* or #).

Ground-Start (GS) signaling

A type of switched access line supervisory signaling in which the network provides a battery source. To initiate a call, CPE or OTC equipment provides a ground on the ring lead. The ring ground causes dc current to flow which the local switching system will detect as a request for service. On terminating calls, CPE or OTC equipment will provide an off-hook loop closure that is recognized as an answer signal.

Line-side

That part of a local switching system that interfaces access lines.

Local switching system

A system that establishes connections between access lines and connections between access lines and interoffice trunks. Access line ports are located on the line-side of the local switching system and trunk ports are located on the trunk-side of the local switching system.

Loop reverse-battery signaling

A type of switched access line supervisory signaling that uses loop open and loop closure signals to indicate on-hook and off-hook signals in one direction and normal battery polarity and reverse battery polarity to indicate on-hook and off-hook signals in the other direction. The end of the service that generates loop open and loop closure signals is called the originating end and the other end which generates the normal battery polarity and reverse battery polarity signals is called the terminating end. For LRTS and other DID-type ports, the local switching system is the originating end and the CPE or OTC equipment is the terminating end. The interface code for such applications represents the function performed by the CPE or OTC equipment (02QC3-RVT).

Loop-Start (LS) signaling

A type of switched access line signaling in which the network provides a battery source. To initiate and maintain a call, CPE or OTC equipment will provide an off-hook loop closure. The loop

closure causes dc loop current to flow which the local switching system will recognize as a service request. On terminating calls, CPE or OTC equipment will provide an off-hook loop closure that is recognized as an answer signal.

Open end

The open end of an access line is the end of the access line that connects to the local switching system port. The open end can be switched to other line or trunk ports associated with the same local switching system.

Other Telephone Company (OTC)

An organization that provides telecommunications services to the public.

Trunk-side

That part of a local switching system that interfaces interoffice trunks.

Unbundled Port

A physical termination (port) on a switching system that provides access to and from the public switched telephone network.

Voice Grade (VG)

A term used to describe a channel, circuit, facility, or service that is suitable for the transmission of speech, digital or analog data, or facsimile, generally with a frequency range of about 300 to 3000 Hz.

B. Acronyms

| | |
|------|---|
| AL | acceptance limit |
| ANSI | American National Standards Institute |
| BA | Bell Atlantic |
| CO | central office |
| CODF | central office distributing frame |
| CPE | customer premises equipment |
| DID | Direct Inward Dialing |
| DP | dial pulse |
| DS1 | digital signal level one |
| DTMF | dual tone multi-frequency |
| GS | ground-start |
| GSLS | ground-start line-side |
| FCC | Federal Communications Commission |
| IAL | immediate action limit |
| IEEE | International Electrical and Electronic Engineers |
| LRB | loop reverse-battery |
| LRTS | loop reverse-battery trunk-side |
| LS | loop-start |
| LSLS | loop-start line-side |

| | |
|------|---|
| NC | network channel |
| NCI | network channel interface |
| NEC | National Electric Code |
| OTC | Other Telephone Company |
| PBX | Private Branch Exchange |
| PIC1 | primary interconnect carrier one |
| PIC2 | primary interconnect carrier two |
| POTS | plain ordinary (analog) telephone service |
| UL | Underwriter's Laboratory |
| UPS | <i>Unbundled Port Service</i> |
| USDL | United States Department of Labor |
| USOC | Universal Service Order Code |
| VF | voice frequency |
| VG | voice grade |

7. Bibliography

- 1- Technical Reference FR-NWT-000064, LATA Switching Systems Generic Requirements (LSSGR). (Bellcore, 1994).
- 2- American National Standard for Telecommunications- Interface Between Carriers and Customer Installations - Analog Voicegrade Switched Access Lines Using Loop-Start and Ground-Start Signaling, ANSI T1.401-1993.
- 3- American National Standard for Telecommunications- Network-to-Customer Installation Interfaces - Direct-Inward-Dialing Analog Voice grade Switched Access Using Loop Reverse-Battery Signaling, ANSI T1.405-1996.
- 4- Generic Requirements GR-63-CORE, Network Equipment-Building System (NEBS) Requirements: Physical Protection, Issue 1. (Bellcore, October 1995).
- 5- Generic Requirements GR-1089-CORE, Electromagnetic Compatibility and Electrical Safety - Generic Criteria for Network Telecommunication Equipment, Issue 2 (Bellcore, November 1994).
- 6- ANSI IEEE 455-1984 (R1993), Test Procedure for Measuring Longitudinal Balance of Telephone Equipment Operating in the Voice Band.
- 7- ANSI IEEE 743- 1995, Standard Methods and Equipment for Measuring the Transmission Characteristics of Analog Voice Frequency Circuits.

NOTE: These documents are subject to change; references reflect the most current information available at the time of printing. Readers are advised to check the status and availability of all documents.