



THOMAS, LONG,
NIESEN & KENNARD

Attorneys and Counsellors at Law

CHARLES E. THOMAS, III
Direct Dial: 717.255.7611
cet3@thomaslonglaw.com

August 1, 2011

Rosemary Chiavetta, Secretary
Pennsylvania Public Utility Commission
Commonwealth Keystone Building
P.O. Box 3265
Harrisburg, PA 17105-3265

RECEIVED
2011 AUG - 1 PM 4:02
SECRETARY'S BUREAU

In re: Pennsylvania Public Utility Commission v. Verizon Pennsylvania, Inc.,
Docket No. R-2011-2234464

Pennsylvania Telephone Association v. Verizon Pennsylvania Inc.,
Docket No. C-2011-2237456

Pennsylvania Public Utility Commission v. Verizon North, LLC,
Docket No. R-2011-2234462

Pennsylvania Telephone Association v. Verizon North, LLC,
Docket No. C-2011-2237496

Dear Secretary Chiavetta:

Enclosed for filing is the Prepared Rebuttal Testimony of Gary M. Zingaretti on Behalf of the Pennsylvania Telephone Association Companies in the above-referenced consolidated proceeding. Copies are being served in accordance with the attached Certificate of Service.

Should you have any questions, please do not hesitate to contact me.

Very truly yours,

THOMAS, LONG, NIESEN & KENNARD

By: 
Charles E. Thomas, III

Encl.

cc: Dennis J. Buckley, Presiding Administrative Law Judge

PTA Statement No. 1
Docket No. C-2011-2237456 *et al.*
Witness: Gary M. Zingaretti
Date Admitted: August 1, 2011

Before the
PENNSYLVANIA PUBLIC UTILITY COMMISSION

Pennsylvania Public Utility Commission	:	
v.	:	Docket No. R-2011-2234464
Verizon Pennsylvania, Inc.	:	
	:	
Pennsylvania Telephone Association	:	
v.	:	Docket No. C-2011-2237456
Verizon Pennsylvania, Inc.	:	
	:	
Pennsylvania Public Utility Commission	:	
v.	:	Docket No. R-2011-2234462
Verizon North, LLC	:	
	:	
Pennsylvania Telephone Association	:	
v.	:	Docket No. C-2011-2237496
Verizon North, LLC	:	
	:	

PREPARED REBUTTAL TESTIMONY OF
GARY M. ZINGARETTI
ON BEHALF OF THE
PENNSYLVANIA TELEPHONE ASSOCIATION COMPANIES

RECEIVED
2011 AUG -1 PM 4:02
SECRETARY'S BUREAU
PA PUC

Dated: August 1, 2011

1 **I. INTRODUCTION**

2 **Q. Please state your name, occupation and business address.**

3 A. My name is Gary M. Zingaretti. I hold the position of Senior Vice President for ICORE,
4 Inc., 326 South Second Street, Emmaus, PA 18049.

5
6 **Q. Please state your relevant experience and education background.**

7 A. I hold a Bachelor of Science Degree in both Accounting and Economics from King's
8 College in Wilkes-Barre, Pennsylvania. Furthermore, I received my Master of Business
9 Administration Degree in Finance from Wilkes University in Wilkes-Barre. I am a
10 Certified Public Accountant in the Commonwealth of Pennsylvania. I joined ICORE in
11 May 2001 with primary responsibility for State and Federal regulatory activity. ICORE's
12 clients are primarily small, rural incumbent local exchange carriers. I assist these clients
13 with revenue and regulatory issues, government relations, negotiations with connecting
14 carriers, expert testimony, and strategic business planning.

15 Prior to joining ICORE, I was a senior executive of Commonwealth Telephone
16 Enterprises, Inc., Dallas, Pennsylvania, where I served as Vice President - Industry
17 Relations. In this capacity, I was responsible for developing and implementing
18 regulatory and revenue policies for the company.

19 I have previously testified on several different occasions in Pennsylvania, on
20 Intrastate Universal Service Funding, Alternative Forms of Rate Regulation, Rate
21 Rebalancing proceedings, and CLEC expanded calling proceeding. I was also an active
22 participant in the Commission's Global Telecommunications Settlement Conferences and
23 assisted in the development of the settlement filed and approved in the subsequent Access

1 Charge Investigation Order (Docket Nos. M-00021596, P-00991648 and P-00991649)
2 entered July 15, 2003. I have served as an expert witness in Federal District Court
3 proceedings centered on ILEC and CLEC access charge billing and tariff interpretation.

4 I have twenty-four years experience in the regulatory and revenue requirements
5 segment of the telecommunications industry. During this time I have been actively
6 involved in industry events via committee participation, and I currently serve as a
7 member of the Board of Directors of the Pennsylvania Telephone Association. A copy of
8 my curriculum vitae is included as Exhibit GMZ-1 to this testimony.

9
10 **II. PURPOSE OF TESTIMONY**

11 **Q. On whose behalf are you submitting your testimony in this proceeding?**

12 A. I am testifying on behalf of the Pennsylvania Telephone Association (“PTA”) member
13 rural local exchange carriers (“RLECs” or “PTA Companies”) operating in Pennsylvania
14 that are identified in the Complaint¹ against tariffs filed by Verizon Pennsylvania and
15 Verizon North (collectively “Verizon”) which introduce Transit Service as a new tariff
16 offering. It is the PTA’s contention that Verizon’s proposed tariff is improper in form
17 and substance, is incorrect, unclear, inappropriate, and wholly unsupported and proposes

¹ For purposes of this proceeding, the PTA Companies are: Armstrong Telephone Company - North, Armstrong Telephone Company - Pennsylvania, Bentleyville Telephone Company, Citizens Telephone Company of Kecksburg, Frontier Communications Commonwealth Telephone Company, LLC (d/b/a Frontier Commonwealth), Frontier Communications of Breezewood, LLC, Frontier Communications of Canton, LLC, Frontier Communications – Lakewood, LLC, Frontier Communications – Oswayo River, LLC, Frontier Communications of PA, LLC, Hickory Telephone Company, Ironton Telephone Company, Lackawaxen Telecommunications Services, Laurel Highland Telephone Company, Mahanoy & Mahantango Telephone Company, Marianna & Scenery Hill Telephone Company, The North-Eastern Pennsylvania Telephone Company, North Penn Telephone Company, Consolidated Communications of Pennsylvania Company (f/k/a North Pittsburgh Telephone Company), Palmerton Telephone Company, Pennsylvania Telephone Company, Pymatuning Independent Telephone Company, South Canaan Telephone Company, Sugar Valley Telephone Company, Venus Telephone Corporation, and Yukon-Waltz Telephone Company.

1 rates and terms that are unnecessarily burdensome on the RLECs. In this testimony, I
2 will address these tariff issues, explain why this service should be the subject of a
3 negotiated contract, not a unilateral tariff filing, and how this filing runs contrary to
4 express intentions of the FCC on matters of compensation for the exchange of local
5 traffic. In this process, I will also offer rebuttal to the Verizon Statement No. 1.0, the
6 Direct Testimony of Peter J. D'Amico, filed with this Commission on July 11, 2011.

7
8 **Q. What experience do you have interpreting tariffs?**

9 A. During my tenure at Commonwealth Telephone, I oversaw the development and
10 implementation of regulatory and revenue policies for both Commonwealth's ILEC and
11 CLEC units. I also led the CLEC unit's multi-state certification and interconnection
12 activities. In 2000, I led the development of Commonwealth's (ILEC) intrastate toll and
13 access tariffs (prior to this, Commonwealth had concurred in the tariffs of the
14 Pennsylvania Telephone Association). I also had direct responsibility for the
15 development of all necessary state and federal CLEC tariffs.

16 At ICORE, my areas of focus include the preparation of access and cost
17 separations studies based on FCC Part 36 and 69 Rules, the administration of National
18 Exchange Carrier Association ("NECA")² settlements, and oversight of the Public
19 Utilities Commission ("PUC") and state legislative activities. In addition, I have
20 provided testimony, training, and presentations before the PA PUC, FCC, legislative sub-

² NECA was formed in 1983 by the Federal Communications Commission to perform telephone industry tariff filings and revenue distributions. Nearly 900 local telephone companies, or "exchange carriers," are members of NECA.

1 committees and administrative law judges. I have prepared or overseen the development
2 of local and/or access tariffs for some 50 companies during my time at ICORE.

3
4 **Q. Do you have any experience negotiating or drafting interconnection agreements?**

5 **A.** Yes. During my time at Commonwealth I was responsible for negotiating
6 interconnection agreements with the incumbent in each new market as part of the overall
7 CLEC multi-state expansion. Since arriving at ICORE in 2001, I have negotiated and
8 supervised the negotiation of multiple interconnection agreements. I negotiated these
9 agreements on behalf of both RLEC and CLEC clients. The agreements were with CLEC
10 and wireless providers.

11
12 **Q. Based on this experience, have you reached any conclusions about the Verizon
13 Pennsylvania and Verizon North tariffs for Tandem Transit Service?**

14 **A.** Yes, I have. As outlined further in this testimony, I conclude that

- 15 1. Verizon's tariffs should not be approved by this Commission.
- 16 2. Transit Service as proposed by Verizon fails to address incoming tandem transit
17 calling.
- 18 3. Transit Service as proposed by Verizon should be provided based on negotiated
19 terms, not a tariff..
- 20 4. The RLECs should not be responsible for the cost of tandem transit to CLECs and
21 Wireless Carriers in distant locations.

1 **III. VERIZON'S TARIFFS SHOULD NOT BE APPROVED BY THIS COMMISSION.**

2 **Q. Have you reviewed Verizon's Chapter 30 plan to determine the basis of Verizon's**
3 **tariff filing?**

4 **A.** I have reviewed the Chapter 30 plan to evaluate its relevance to this proceeding. It
5 appears that Verizon's position is that this matter is a legal issue³ and, to a certain extent,
6 *I agree with that assertion. I am certain that the PTA's counsel will address these legal*
7 *matters in briefs. However, Verizon then claims that "As a factual matter, however, there*
8 *is competition for local transit service..."*⁴ If the presence of competitors in the market
9 place was all that was required to have a service deemed competitive, then that's what the
10 Verizon Chapter 30 Plan would state. Moreover, given the presence of a host of
11 communications options, every telephone service would be competitive under that theory.
12 Verizon's Chapter 30 plan indicates that the classification of a new or existing service as
13 "competitive" is a specific process:

14 "When the Company requests that new or existing services be classified as
15 competitive, a sixty (60) day notice procedure shall be followed. The
16 public shall be notified by general newspaper notice, billing insert or bill
17 message. Such request for competitive classification shall be served in
18 hand upon the Office of Trial Staff, the Office of Consumer Advocate, the
19 Office of Small Business Advocate, all intervenors in this Chapter 30
20 proceeding and any other person as directed by the Commission's
21 Secretary on the day of filing with the Commission. Any complaint or
22 comment in support of, or opposition to, the proposed classification shall
23 be filed with the Commission within twenty (20) days of the original
24 filing. The Company may respond within ten (10) days thereafter. The
25 Commission shall enter an Order within one hundred eighty (180) days of
26 the filing date concerning the service's competitive status; otherwise, the
27 service shall be deemed to be competitive."
28

³ See VZ St. 1.0 D'Amico Direct at Page 9, Line 17.

⁴ See VZ St. 1.0 D'Amico Direct at Page 9, Lines 20-21.

1 *See Final Alternative Regulation Plan of Verizon North Inc., Docket No. P-00981449,*
2 *Revised on October 10, 2002.* I am not aware of Verizon’s position on whether this
3 provision has been superseded by the later-enacted substitute for Chapter 30, but even
4 that provision requires a filing and notice.⁵

5 To date, the PTA has not received any proof that a single step of this process was
6 completed by Verizon as part of the introduction of this tariff. When Verizon introduces
7 a competitive service, it’s Chapter 30 obligation is to “...file informational tariffs for
8 services declared competitive...”⁶ This could have been accomplished by filing a new
9 competitive service in the Verizon Pennsylvania, Inc. PA PUC Tariff No. 500,
10 Informational Tariff for Competitive Services. This would not be a new concept for
11 Verizon, as they already have approximately 80 competitive services and/or markets in
12 that tariff. Instead, Verizon filed a new, fully regulated, non-competitive services tariff
13 with the PUC through which it will end-run both the negotiation process for an
14 appropriate agreement and their Chapter 30 obligations, unless the Commission dismisses
15 the tariffs.

16
17 **Q. What is the historic relationship of the PTA Companies and Verizon in so far as the**
18 **instant filing is concerned?**

⁵ There is also a process to have protected services declared competitive, but, since we do not think this likely, have not addressed it here.

⁶ See Bell Atlantic Pennsylvania Inc.’s Alternative Regulation Plan, Part 2 – Competitive Services Deregulation Plan, sub-part A – Impact and Benefits.

1 A. The PTA Companies are rural local exchange companies (“RLECs”) in Pennsylvania
2 which serve exceedingly rural areas of Pennsylvania and are the carriers of last resort for
3 both broadband and voice services in these difficult and expensive to serve territories.⁷
4 Under the architecture of the Pennsylvania public switched network (“PSTN”), many of
5 the PTA Companies’ end office switches are connected to the Verizon tandems
6 (“subtend” in industry parlance). Verizon is the dominant tandem provider in
7 Pennsylvania. When Verizon enters into an interconnection agreement with another
8 carrier, Verizon also contemplates that it will provide tandem switching and transit
9 services on traffic destined for the sub-tending carriers.

10 At the time of AT&T divestiture, Verizon, then Bell Atlantic, and the PTA
11 Companies executed a series of agreements, including the Telephone Services and
12 Facilities Agreement (“TSFA”) specifying how their networks would be interconnected
13 and compensation. The TSFA was a voluntary process between Bell and the RLECs,
14 upon the introduction of toll competition attendant the AT&T/Bell Modified Final
15 Judgment, to replace the preexisting toll revenue settlement process between Bell and the
16 ILECs. It has been modified several times since it was originally entered into, including
17 as to the delivery of local traffic originated by third parties. At no time, of which I am
18 aware, did Verizon state that it wished to open an industry dialogue regarding third party
19 local traffic delivered by the RLEC to the Verizon tandem.

20
21 **Q. What is the history leading up to the filing of these tariffs and the request by**
22 **Verizon to all of the PTA Companies seeking a transit rate as you know it?**

⁷ The small companies serve far fewer lines per square mile than Verizon at generally a higher cost per customer.

1 A. As I understand it, on November 15, 2010 Verizon sent a letter to the PTA Companies
2 asking for a transit rate. There were several joint calls in December 2010 and, in January
3 2011, Verizon proposed an off the shelf ICA designed for CLECs that contained what the
4 RLECs believed were far more cumbersome terms and addressed far more than just
5 transit service. The RLECs immediately suggested that the Parties meet to work out a
6 term sheet and then develop an ICA around the term sheet. Verizon refused to participate
7 in such an approach, so the RLECs proceeded to modify the January draft
8 Interconnection agreement to have it more appropriately reflect the limited issue of transit
9 service which was being addressed. It advised Verizon that it was doing so. Throughout
10 the weeks that modification was being performed, RLEC counsel and others repeatedly
11 reported to Verizon the status of that effort and a responsive draft was promised to
12 Verizon in early April, but Verizon then proceeded to file the subject tariffs. The RLECs
13 continued to believe that an agreement is the way to proceed and therefore finalized an
14 ICA and presented it to Verizon shortly after the tariff was filed. It was three months
15 before Verizon provided any reaction to that document. The RLECs continue to attempt
16 to negotiate an agreement. Verizon's attempts to claim that the RLECs are foot dragging
17 is name calling and posturing. The PTA companies have also waited three months for a
18 response from Verizon. Verizon has also sent the PTA Companies a non-redlined draft
19 when it finally did reply. The PTA Companies provided a red-lined mark-up quickly
20 after Verizon requested one.

1 **Q. Are the rates included in the Verizon tariffs appropriate?**

2 A. If one were to consider just the Verizon PA per minute rate, based on TELRIC principles,
3 it could be considered appropriate. There is no such rate development for Verizon North,
4 as far as I know. And, I have concerns about rate design. The rate is billed on a per
5 minute basis but the rate development indicates it includes a mileage sensitive
6 component. Based on the tariff language, it appears there will not be a per-mile charge
7 beyond the 1 mile included in their rate development⁸. This point should be more
8 expressly detailed in the Verizon tariff.

9
10 **Q. Are the terms and conditions included in the Verizon tariffs appropriate?**

11 A. No. Verizon's terms and conditions impose new, and potentially significant, network
12 costs on the RLECs that are above and beyond the rates included in Verizon's tariff. For
13 instance, RLECs would be forced to reconfigure Interconnection facilities per Section
14 3.5.1 of the proposed tariff.

15 3.5.1 Established Interconnection

16
17 The customer must have interconnection to each Telephone Company Tandem in
18 each LATA where the customer delivers any Tandem Transit Traffic to the
19 Telephone Company. Upon commercially reasonable notice, the customer shall
20 cooperate with and assist the Company in reconfiguring Interconnection facilities,
21 and the trunk groups riding on such interconnection facilities, for use in
22 connection with such services.

23
24 For example, Verizon could demand that the PTA Companies split out existing trunks to
25 separate traffic. We have no idea what this will cost and, as far as we know, neither does
26 Verizon. The language is too vague. The tariff provides that we SHALL reconfigure
27 interconnection facilities, essentially as Verizon directs and we have no say. Such a

⁸ See VZ St. 1.0 D'Amico Direct at Page 11, Lines 6-7.

1 provision is totally inappropriate and unfair. We also believe that such requests have not
2 been imposed on all other carriers, thus, discriminating against the PTA Companies

3 Section 3.5.1 also requires the PTA Companies to “have interconnection to each
4 Telephone Company [Verizon] Tandem in each LATA where the customer [PTA
5 Company] delivers any Tandem Transit Traffic to the Telephone Company.” The
6 RLECs deliver traffic to Verizon currently without such multiple trunks. The RLECs
7 cannot predict this additional cost, and neither can Verizon. This will require RLECs to
8 duplicate their Tandem Transit trunks, since they would have to interconnect to at least
9 two tandems in each LATA. As discussed elsewhere, should Verizon re-home an end
10 office to a different tandem, this action could cause the RLEC to invest in new
11 infrastructure to connect to Verizon. RLECs and their customers would be better served
12 investing in their broadband infrastructure rather than playing a game of “follow the
13 leader” in search of Verizon end offices.

14 For example, today, a single exchange RLEC might only have one connection to
15 Verizon for the traffic defined in the proposed tariff. Since Verizon wants this traffic
16 delivered via separate trunk groups, approval of this tariff would require two more trunk
17 groups just to continue to exchange traffic to that same Verizon tandem. The growth in
18 trunk groups is significant when you have recognize there are multiple Verizon tandems
19 and/or multiple RLEC switches. For example, consider the following:

RLEC Switches	Current Network Trunks	Proposed Tariff 2 Tandems	Proposed Tariff 3 Tandems
1	1	6	9
2	1	12	18
3	1	18	27
4	1	24	36
5	1	30	45

20

1 It is discriminatory and not necessary and is an example, contrary to their statements, of
2 how this tariff does more than charge for a service – it obligates the RLECs to new
3 capital and operating costs as directed by Verizon.

4 Third, the facilities that will connect the RLECs and Verizon have not been
5 defined in the tariff. As an example, there is no reference in the tariff to whether this
6 interconnection will be accomplished over one-way or two-way trunk groups. Verizon's
7 own Interconnection Agreements with other service providers contemplates the use of
8 two-way trunk groups,⁹ including the conversion of one-way trunk groups to two-way
9 trunk groups.¹⁰ In Verizon's standard commercial agreement for Tandem Transit Traffic,
10 *one-way trunk groups are required. How are trunk groups determined if the Verizon*
11 *tariff does not include the same network considerations that are included in negotiated*
12 *agreements? Although the PTA does not agree that one-way trunk groups are*
13 *appropriate, this issue could and should have been negotiated in the context of an*
14 *agreement, not a tariff. Without clear language addressing the form of interconnection,*
15 *the PTA companies will be at the mercy of Verizon's (non)willingness to negotiate on*
16 *this issue. The requirement to "cooperate and assist the Company in reconfiguring*
17 *interconnection facilities, and the trunk groups riding on such interconnection facilities"*¹¹
18 *is hardly a blueprint of specificity for interconnection. If Verizon requires the PTA*
19 *Companies to change their configuration to suit Verizon, Verizon needs to be much more*

⁹ For instance, see the Verizon Interconnection Agreement with 321 Communications, filed with the PA PUC on July 22, 2010 ,Interconnection Attachment, Section 2.4 Two-Way Interconnection Trunks.

¹⁰ See Verizon Interconnection Agreement with 321 Communications, filed with the PA PUC on July 22, 2010 ,Interconnection Attachment, Section 2.4.3

¹¹ Section 3.5.1 of proposed Verizon PA PUC No 219.

1 forthcoming as to the facilities changes contemplated and the impact on the PTA
2 Companies.

3 Fourth, the PTA companies remain concerned about billing issues that result from
4 incomplete tariff definitions proposed by Verizon. The PTA contended in its complaint
5 that the term “Local Service Provider” must be revised so as to exclude Verizon and any
6 third party’s network that uses Verizon’s switching to provide its end user service. In
7 response to this, Verizon states that “...the definition of Tandem Transit Traffic already
8 excludes such [Verizon] customers.”¹² Verizon’s testimony fails to address the second
9 half of that objection, that customers of third party providers that utilize Verizon’s
10 switching must be removed from the equation as well. Without this correction, calls
11 delivered to resellers of Verizon’s service could result in charges being billed to the
12 RLECs. Verizon would also bill the RLEC to provide Tandem Transit service when
13 these calls are delivered to CLECs purchasing products like Verizon Wholesale
14 Advantage, a “bundle of loop, switching, and enhanced features such as Voice Mail,
15 offered through a commercially negotiated agreement between Verizon and a CLEC.¹³ It
16 would seem that this may result in Verizon being compensated twice for the same
17 service.

18 Moreover, the definition of exchange access in the tariff is vague, as it refers to
19 the definition contained in the Telecommunications Act. That is not a working definition
20 of the type employed in the industry, defined by the FCC or by this Commission.
21 Verizon states that the tariff definition is intended to “distinguish local traffic (e.g. traffic

¹² See VZ St. 1.0 D’Amico Direct at Page 17, Lines 22-24.

¹³ See Verizon website at <http://www22.verizon.com/wholesale/local/order/services/1,,platform-platform.00.html>, visited July 28, 2011.

1 'within a telephone exchange') from toll traffic (traffic that passes from one exchange to
2 another)".¹⁴ A closer look reveals that, by relying on definitions provided in the
3 Telecommunications Act, Verizon's tariff creates ambiguities which will certainly lead to
4 billing disputes. Part A of section 2.6 in the proposed tariff calls for the traffic to be (1)
5 within a telephone exchange, or (2) within a connected system of telephone exchanges
6 within the same exchange area. Part B of section 2.6 provides another definition, but that
7 is premised upon such services being "comparable". Under these definitions, the only
8 time (for example) that Ironton Telephone Company would pay Verizon for tandem
9 transit is when an Ironton caller calls a customer of another service provider within the
10 Ironton exchange. The RLECs are skeptical that it is Verizon's intent to only apply
11 transit charges when a call originates and terminates "within a telephone exchange". The
12 PTA Companies can make a strong argument that, under the Verizon tariff, the only
13 Tandem Transit charges that could ever be charged would be for calls within a single
14 RLEC exchange, from an RLEC customer to a customer of another service provider.
15 There is no doubt that Verizon's position would be different – for instance they are likely
16 to look for Tandem Transit charges on intra-MTA wireless traffic, since this is considered
17 local for purposes of intercarrier compensation. This might be consistent with their
18 testimony, but is not consistent with their tariffs as explained above. Is a call from Forest
19 City to a wireless subscriber in upstate Vermont either (1) service within a telephone
20 exchange, or (2) within a connected system of telephone exchanges within the same
21 exchange area, or (3) a service that is comparable to either 1 or 2 herein? It would be an
22 intra-MTA call. If Verizon wants to bill Tandem Transit charges for "local" calls as

¹⁴ See VZ St. 1.0 D'Amico Direct at Page 18, Lines 24-26

1 indicated in their testimony, their tariff must be re-written to match the testimony. As
2 discussed elsewhere, a negotiated contract would be the better solution to this problem.
3 The attached draft ICA sets forth a more specific and workable definition.

4
5 **IV. TRANSIT SERVICE AS PROPOSED BY VERIZON FAILS TO ADDRESS**
6 **INCOMING TANDEM TRANSIT CALLING**

7
8 **Q. Do you agree that the only traffic at issue in this tariff is local traffic originating**
9 **from the RLEC?**

10 A. Not at all. Incoming traffic is also an issue. The PTA disagrees that Tandem Transit
11 Service is a one-directional offering, but under Verizon's tariff language Tandem
12 Transit applies only to outgoing traffic. Obviously, we also receive Tandem Transit
13 Traffic. This in and of itself should illustrate how overly restrictive the tariff is and is yet
14 another basis for the Commission to reject the filing. In response to the PTA's concerns,
15 Verizon refuses to discuss the issue ("The only traffic at issue for this transit service is
16 local traffic originating from the RLEC.").¹⁵ Although Verizon fails to provide a
17 specific reference to support this statement, Section 3.5.4 of the tariff states "The
18 customer may use the service only for Tandem Transit Traffic that originates on the
19 customer's network".

20 The PTA Companies have been seeking for some time to ensure that the traffic
21 that Verizon sends through to the RLECs contains the calling information necessary for
22 billing purposes. This lack of detail continues to nag the PTA Companies. Some of the
23 problem related to the carriers themselves involved in delivering the call to Verizon. A
24 good example of this is exemplified in the ICA that Verizon has requested be approved

¹⁵ See VZ St. 1.0 D'Amico Direct at Page 17, Lines 1-2.

1 by the Commission with a company called Halo Wireless.¹⁶ Not only does Halo
2 misrepresent the nature of traffic, the calls are delivered to the sub-tending LECs with no
3 originating number (Calling Party Number or “CPN”) in the billing records, but rather a
4 billing telephone number (“BTN”) is intentionally inserted into the call detail record.
5 The BTN provided is local to the called number in order to make the call appear to be
6 local, and to enable such traffic to flow over local interconnection trunks instead of IXC
7 trunks.¹⁷ The other, related problem is caused by Verizon itself stripping out call details
8 and inserting zeros instead. This is a well known problem that Verizon barely
9 acknowledges and refuses to do anything about. If the PTA Companies are required to
10 provide accurate CPN and other billing data, the tariff should specify that, so too, are the
11 PTA Companies entitled to receive such information and that Verizon, as the Tandem
12 Operator, is obligated to ensure that neither it nor anyone else strips the data out of the
13 call.

14 As indicated in Exhibit GMZ-2, Verizon touts a (non-tariffed) Access Tandem
15 Connection (“ATC”) service which provides transiting from the service provider *to both*
16 *Verizon and non-Verizon* end offices. The service provider purchasing this service is
17 buying an outbound transiting service by which the RLEC’s offices can be reached. In
18 marketing this ATC service, Verizon states that the service allows the purchaser to *send*
19 *and receive* traffic to third parties. So purchasers of a product that provides tandem
20 transit – ATC service – are buying a 2-way product, but the RLECs are only receiving a

¹⁶ *Joint Petition of Verizon Pennsylvania Inc. and Halo Wireless Services, Inc. for Approval of an Interconnection Agreement and Amendment No. 1 to the Interconnection Under Section 252(e) of the Telecommunications Act of 1996*, Docket No. A-2011-2251147; and *Joint Petition of Verizon North LLC and Halo Wireless Services, Inc. for Approval of a Wireless Interconnection Agreement and Amendment No. 1 Under Section 252(e) of the Telecommunications Act of 1996*, Docket No. A-2011-2250700.

¹⁷ The PTA intends to file Comments to this ICA, which are incorporated by reference.

1 1-way service. This is discriminatory as the transit service provided by ATC is the same
2 as what Verizon proposes in their tariff. A purchaser of Tandem Transit service should
3 have access to accurate records reflecting both sides of this equation. This is yet another
4 reason why Verizon's tariff is inappropriate for Tandem Transit service.
5

6 **V. TRANSIT SERVICE AS PROPOSED BY VERIZON SHOULD BE PROVIDED**
7 **BASED ON NETOGIATED TERMS, NOT A TARIFF.**

8
9 **Q. Is Transit Service typically an offering included in interconnection agreements?**

10 **A.** Yes, Transit Service has been included in every interconnection agreement that I have
11 negotiated. Verizon admits that it has nearly 300 interconnection agreements that
12 provide for Tandem Transit Service.¹⁸ That being said, the only reason to tariff the
13 service is because Verizon claims to have been unsuccessful in prior negotiations with
14 the RLECs. As previously noted the RLECs were fully engaged in the process of
15 negotiating an Agreement when the Tariff was filed. The RLECs continue to believe that
16 a tariff is not the proper mechanism and request that the Commission direct the
17 negotiation of an agreement. A template for such an agreement is attached hereto as
18 Exhibit GMZ-3 and fully addresses the provision of transit service between Verizon and
19 the RELCs. Given the concerns expressed in the PTA's complaint in this case, as well as
20 additional issues raised in this testimony, the Commission should not allow Verizon to
21 manipulate the regulatory process to obtain negotiating leverage.

¹⁸ See VZ St. 1.0 D'Amico Direct at Page 5, Lines 18-20.

1 **Q. Is Verizon's ATC Service tariffed?**

2 A. No, Verizon's ATC service is offered as "a standard interconnection under 251/252"¹⁹.

3 In the FCC's *T-Mobile Order*, wireless carriers, including Verizon's own affiliate

4 Verizon Wireless argued that "...imposing the terms of interconnection pursuant to a

5 tariff regime is inconsistent with the negotiation processes contained sections 251 and 252

6 of the Act..."²⁰ So Verizon's affiliates do not want interconnection to be offered under

7 tariff, but Verizon wishes to impose that obligation upon the RLECs in this proceeding.

8 Of course the difference is that Verizon would be paid under the terms of this tariff while

9 Verizon Wireless would have owed money in the wireless termination tariffs. The

10 Verizon -testimony constantly cites, as authority, the ICAs it has negotiated with others.

11 That is what we are trying to do. Verizon even uses the PUC approved ICAs as the

12 support for the Verizon North rate – which is otherwise not the subject of a PUC order.

13

14 **Q. Doesn't the Verizon Tariff allow for the negotiation of contracts for Tandem Transit**
15 **Service?**

16 A. It does, but one must consider what incentive Verizon will have to negotiate any
17 contractual agreement with the RLECs, if their tariff is allowed to become effective.

18 While it would be a legal matter, it is unclear to me how Verizon can offer a tariff for
19 services and then, while that tariff is still in effect, offer different deals to other parties.

20 Also, as it has everything that it seeks in the tariff, Verizon has no incentive to negotiate
21 and the RLECs have no means of forcing Verizon to the negotiating table.

¹⁹ See Exhibit GMZ-2, Page 1.

²⁰ See, *Order In the Matter of T-Mobile et al. Petition for Declaratory Ruling Regarding Incumbent LEC Wireless Termination Tariffs*, CC Docket No. 01-92, Released February 24, 2005, ¶ 13 and footnote 50.

1 **Q. Are there other tariff concerns?**

2 **A.** Yes. The PTA Companies believe that the Verizon placeholders for monthly recurring
3 charges and non-recurring charges should be removed from the tariff if the Commission
4 were to adopt Verizon's proposal. Verizon even acknowledges its willingness to do
5 make this change.²¹

6
7 **VI. THE RLECS SHOULD NOT BE RESPONSIBLE FOR THE COST OF TANDEM**
8 **TRANSIT SERVICE TO CLECS AND WIRELESS CARRIERS IN DISTANT**
9 **LOCATIONS.**

10
11 **Q. Under what mandates are the RLECs interconnecting to third parties for the**
12 **exchange of local traffic?**

13 **A.** In the Telecommunications Act of 1996, all LECs had certain responsibilities established
14 in order to achieve efficient interconnection. In Section 251(a)(1), each LEC "has the
15 duty to interconnect directly or indirectly with the facilities and equipment of other
16 telecommunications carriers...". This obligation applies to all telecommunications
17 carriers. Beyond this, *incumbent* local exchange carriers are bound by certain other
18 requirements. Section 251(c)(2)(B) requires this interconnection to occur "at any
19 technically feasible point within the carrier's network."²² While *all* LECs are required to
20 interconnect, it is only the *incumbent* LECs that have a specific geography where
21 interconnection is to occur.

²¹ See VZ St. 1.0 D'Amico Direct at Page 26, Lines 21-22.

²² See 251(c)(2)(B)

1 **Q. What is the significance of this Interconnection Point?**

2 A. This point where the carrier networks meet is referred to as the Point of Interconnection
3 (“POI”). Verizon defines the POI as “the physical location where the Parties' respective
4 facilities physically interconnect for the purpose of mutually exchanging their traffic.”²³
5 The POI is significant because it is the demarcation point at which each party becomes
6 financially responsible for the cost of interconnection. As set forth in various
7 interconnection agreements, “each party, at its own expense, shall provide transport
8 facilities to the Point(s) of Interconnection on Verizon’s network in a LATA...”²⁴ I
9 have not done a comprehensive review of all of Verizon’s 297 PUC-approved
10 interconnection agreements, but I would expect to find similar language in these
11 documents. The indirect interconnection that the RLECs currently have with Verizon
12 satisfies the obligations set forth 251(a)(1).

13
14 **Q. Are you suggesting that Verizon should provide Tandem Transit Service for free?**

15 A. No, I am not. To interconnect with an ILEC, other providers need to have facilities
16 which meet the ILEC in the ILEC’s service area. Interconnecting carriers can include
17 other CLECs, CMRS, interconnected VoIP providers and others. For purposes of this
18 Q&A, I will use CLECs in my example, but the same applies to CMRS, interconnected
19 VoIP, and other non-ILEC service providers. Many providers choose to obtain this ILEC
20 interconnection through Verizon’s access tandem. In my experience working with
21 CLECs, this decision is made by comparing the rates, terms and conditions of indirect

²³ See Glossary Section 2.70, in the Two Way Wireless Attachment to the Agreement between Verizon Pennsylvania and Halo Services, Inc. filed with the PA PUC July 5, 2011.

²⁴ See, for example, Interconnection Agreement between Verizon Pennsylvania and NexGen Networks, filed with the PA PUC on December 18, 2009.

1 interconnection through Verizon to the direct cost of ordering facilities to the ILEC POI.
2 A decision by a CLEC to indirectly interconnect with an ILEC through a Verizon tandem
3 is made by the CLEC, not the ILEC. The CLEC decided how it would route both
4 incoming and outgoing traffic to the ILEC's POI and the CLEC should be responsible for
5 payment of all Tandem Transit charges.

6 *I do believe the ILECs may also face limited circumstances where they could be*
7 *billed Tandem Transit charges. This would include the situation of one ILEC delivering*
8 *local traffic to another ILEC through a Verizon tandem. This Extended Area Service*
9 *("EAS") could be delivered to the terminating ILEC via direct trunks between the two*
10 *ILECs. If instead they choose to route this traffic through a Verizon Tandem, transit*
11 *charges should apply. It should be noted that this goes even beyond what I described*
12 *earlier as the restrictions based on a reasonable interpretation of the Verizon tariff as*
13 *drafted. However, the ILECs should reach this conclusion after negotiating an agreement*
14 *with Verizon, the same right afforded nearly 300 other service providers.*

15
16 **VII. OTHER SPECIFIC REBUTTAL OF ISSUES AND STATEMENTS RAISED IN**
17 **VERIZON'S STATEMENT 1.0.**

18
19 **Q. Do you have any other issues with Verizon's Statement 1.0?**

20 **A.** Yes, I do. Verizon's Statement 1.0 claims that affiliates of PTA companies have already
21 agreed to the same rates for Tandem Transit Traffic that are proposed in the pending
22 tariff²⁵. This statement is offered by Verizon to support the "just and reasonable"
23 requirement of Verizon's tariff rate. More to point, it illustrates that CLECs and CMRS
24 providers are different than ILECs and as such they have different requirements for

²⁵ See VZ St. 1.0 D'Amico Direct at Page 14, Lines 4-9.

1 interconnection. The ILECs know that their CLEC/CMRS affiliates are required to
2 interconnect “on” the ILEC network. They chose to negotiate an agreement with Verizon
3 for this interconnection. If ILECs are financially responsible for transiting service
4 provided “off their networks”, then they too should be able to obtain this through
5 negotiation, not a tariff filing.

6 *In attempting to diminish the importance of tandem providers generating accurate*
7 *call records, Verizon claims that “the RLECs’ arguments about phantom traffic are*
8 *overblown...”²⁶ They then claim that federal action is needed to fix phantom traffic.²⁷ It*
9 *is odd that on one hand Verizon thinks that billing factors will solve the industry’s*
10 *phantom traffic woes, while at the same time they negotiate interconnection agreements*
11 *that call for the passing of Calling Part Number (“CPN”) on at least 90% of calls carried*
12 *over the Interconnection Trunks.²⁸ If CLECs are agreeing to pass CPN to Verizon in*
13 *interconnection agreements, why shouldn’t the RLECs have the same right to receive*
14 *CPN? If this were a negotiated agreement they might, but through their tariff, Verizon*
15 *avoids this issue.*

16 Also, Verizon claims that the RLECs have other options for Tandem Transit
17 service, pointing to the presence of companies such as Neutral Tandem²⁹. It is worth
18 noting that even the quote Verizon chose from the Neutral Tandem website describes its
19 service as “a more efficient and cost-effective means for competitive carriers to route

²⁶ See VZ St. 1.0 D’Amico Direct at Page 29, Lines 2-3.

²⁷ See VZ St. 1.0 D’Amico Direct at Page 29, Lines 30-32.

²⁸ See Section 6.1, in the Two Way Wireless Attachment to the Agreement between Verizon Pennsylvania and Halo Services, Inc. filed with the PA PUC July 5, 2011.

²⁹ See VZ St. 1.0 D’Amico Direct at Page 6, Lines 18-19.

1 local traffic to one another”³⁰ Neutral Tandem may be providing Tandem Transit service,
2 but its core market is not the ILEC industry. In fact, a more thorough review of their
3 website indicates that Neutral Tandem transformed how “wireless, cable, CLEC, and
4 broadband telephone companies route local transit traffic to one another”³¹ The lack of
5 ILECs in this statement is not surprising since the networks of ILECs and incumbent
6 tandem providers like Verizon have been interconnected for years. Verizon states that
7 the RLECs have not considered alternative transit options because “they currently use
8 Verizon’s network to transit their local traffic without paying for it.”³² Verizon ignores
9 the fact that these interconnection facilities are already in place and to replace them
10 would be a potentially significant capital outlay. In addition, the RLECs are paying for
11 the exchange of local traffic as contemplated by the FCC – up to the point of
12 interconnection on their network.

14 VIII. CONCLUSION

15 **Q. Do you have anything further to address?**

16 A. Let me just conclude by stating that Verizon’s attempt to tariff a service which has been
17 and continues to be the end product of negotiated interconnection agreements should be
18 rejected by this Commission. If this Commission accepts that a tariff can be filed by
19 Verizon, it should (1) determine whether the tariff has been lawfully filed, and (2) if
20 lawfully filed, Verizon should be required to file tariff changes to correct the issues
21 identified by the PTA.

³⁰ See VZ St. 1.0 D’Amico Direct at Page 7, Lines 8-9.

³¹ See www.neutraltandem.com/prodServices/index.htm or Exhibit GMZ-4.

³² See VZ St. 1.0 D’Amico Direct at Page 6, Lines 11-12.

1 This concludes my responsive testimony at this time. To the extent that any points
2 raised in Verizon's tariff filings or direct testimony were not specifically addressed in
3 these comments does not mean the PTA agrees with those issues. I specifically reserve
4 the right to offer additional testimony as the schedule in this proceeding allows.

RECEIVED

2011 AUG -1 PM 4:02

PA PUC
SECRETARY'S BUREAU

EXHIBIT GMZ-1

Gary M. Zingaretti
Senior Vice President
ICORE, Inc.
326 South Second Street
Emmaus, Pennsylvania 18049
(610) 928-3944

Mr. Zingaretti has more than twenty years experience in the regulatory and revenue requirements segment of the telecommunications industry. Mr. Zingaretti's involvement in the industry during this time has included training sessions and committee participation. Mr. Zingaretti is a Certified Public Accountant and serves as a member of the Board of Directors of the Pennsylvania Telephone Association.

EDUCATION

Mr. Zingaretti received Bachelor of Science degrees in both Accounting and Economics from King's College, and a Master of Business Administration Degree in Finance from Wilkes University, both located in Wilkes-Barre, Pennsylvania.

PROFESSIONAL EXPERIENCE

- **Commonwealth Telephone Enterprises Inc. – Dallas, Pennsylvania, 1986-1995; 1997-2001.**

Began as access billing analyst, responsible for the accuracy of access charge bills rendered to interexchange carriers.

In 1987 was given responsibility for revenue administration ensuring the accuracy of all tariffed revenues billed to carriers and end user customers. Mr. Zingaretti progressed from supervisor to senior manager, assuming additional budgeting billing and rate-making responsibilities. Left for one year in 1996, but returned as a Senior Executive, serving as Vice President-Industry Relations. As such, was responsible for developing and implementing regulatory and revenue policies within the company.

- **ICORE, Inc. – Emmaus, Pennsylvania 1996; 2001 - Present**

Served as Vice President at ICORE in 1996. Returned to ICORE in 2001 as Senior Vice President with primary responsibility for State and Federal regulatory activity. Assists ICORE's clients, primarily small, rural incumbent local exchange carriers, with revenue and regulatory issues, government relations, negotiations with connecting carriers, expert testimony, and strategic business planning.

Responsibilities at both Commonwealth Telephone Enterprises, Inc. and ICORE, Inc. included interstate and intrastate tariff development and filing. Has authored or led the direction of approximately 30 tariffs filed on behalf of 50 companies.

TESTIMONY, FILINGS AND PRESENTATIONS

- **Pennsylvania Public Utility Commission Docket No. I-00940035.** Intrastate Universal Service Funding Proceeding
- **Pennsylvania Public Utility Commission, Docket No. P-00961024.** Petition for Alternative Regulation and Network Modernization Plan of Commonwealth Telephone Company.
- **Pennsylvania Public Utility Commission, Docket No. P-00971182.** Petition for Alternative Regulation and Network Modernization Plan of Ironton Telephone Company.
- **Pennsylvania Public Utility Commission, Docket No. P-00971229.** Petition for Alternative Regulation and Network Modernization Plan of Citizens Telephone Company of Kecksburg.
- **Pennsylvania Public Utility Commission, Docket No. R-000974128.** PA PUC and OCA vs. Commonwealth Telephone Company (Revenue Neutral Rate Rebalancing Proceeding).
- **Pennsylvania Public Utility Commission, Docket No. P-000991648 and P-000991649.** Represented Commonwealth Telephone Company in front of the PA PUC in these dockets which became known as the PA PUC Global Proceeding.
- **Pennsylvania Public Utility Commission, Docket No. I-00020093.** On the record presentation before PA PUC ALJ on Virtual NXX Inter-carrier Compensation issues.
- **Indiana Utility Regulatory Commission, Cause No. 42067-DEL-38, March 15, 2002.** In the Matter of the Commission's certification of rural carriers' eligibility to receive federal high cost universal support, pursuant to the Telecommunications Act of 1996, the FCC's May 23, 2001 Order, and other related FCC orders. Filed a written plan and testimony on behalf of Northwestern Indiana Telephone Company regarding the disaggregation of federal universal service support.
- **Montana Public Service Commission, May 13, 2002.** Filed a written plan on behalf of Ronan Telephone Company regarding the disaggregation of federal universal service support.
- **Montana Public Service Commission, May 13, 2002.** Filed a written plan on behalf of Hot Springs Telephone Company regarding the disaggregation of federal universal service support.
- **Pennsylvania PUC Docket No. I-00030096, July 13-14, 2004.** Generic Investigation in re: Local Carrier Compensation if a Competitive Local Exchange Carrier Defines Local Calling Areas Differently than the Incumbent Local Exchange Carrier's Local Calling Areas but Consistent with Established Precedent.

- **Pennsylvania PUC Docket No. A- 310922F0002, February 21-22, 2006.** Testified on behalf of the Pennsylvania Telephone Association in the Application of Core Communications, Inc., for authority to amend its existing certificate of public convenience and necessity and to expand Core's Pennsylvania operations to include the provision of competitive residential and business local exchange telecommunications services throughout the Commonwealth of Pennsylvania.
- **Pennsylvania PUC Docket No. A- 310922F0002.** Petition of Core Communications, Inc., for Arbitration of Interconnection Rates, Terms and Conditions Pursuant to 47 U.S.C. § 252(b). Filed Direct (1/18/08) and Surrebuttal (2/26/08) Testimony on behalf of the Pennsylvania Telephone Association regarding appropriate terms and conditions for interconnection with rural LECs.
- **Iowa Utilities Board Docket No. FCU-07-2.** In re: Qwest Communications Corp (Complainant) vs. Superior Telephone Company et. al.; Reasnor Telephone Company (Counterclaimant) vs. Qwest Communications Corp. and Qwest Corp.
 - Filed Direct Testimony on behalf of Reasnor Telephone Company regarding the appropriate application of interexchange access charges on terminating long distance conference calls.
 - Deposition provided on behalf of Sully Telephone (09/18/07)
 - Deposition provided on behalf of Reasnor Telephone Company (11/19/08)
- **Pennsylvania PUC Docket No. C- 2009-2093336.** Palmerton Telephone Company v. Global NAPs South, Inc., Global NAPs Pennsylvania, Inc., Global NAPs Inc., and other affiliates. Provided expert testimony (07/10/09) on behalf of Palmerton Telephone Company addressing claims by Global NAPs that access charges are not required for Enhanced Services or Interconnected Internet Protocol Traffic.
- **Pennsylvania PUC Docket No. I-00040105 and C-2009-2098380,et.al.** Investigation Regarding Intrastate Access Charges and IntraLATA Toll Rates of Rural Carriers, and the Pennsylvania Universal Service Fund; AT&T Communications, et al. v Armstrong Telephone Company of Pennsylvania et al., Filed Direct, Rebuttal, and Surrebuttal Testimony on behalf of the Pennsylvania Telephone Association.
- **Connect America Fund; a National Broadband Plan for Our Future, Establishing Just and Reasonable Rates for Local Exchange Carriers; Developing a Unified Intercarrier Compensation Regime, etc.** Filed comments with the Federal Communications Commission (04/01/11) addressing phantom traffic, intercarrier compensation obligations for VoIP traffic, and rules to address access stimulation on behalf of multiple small RLECs.

FEDERAL COURT: EXPERT DISCLOSURE, DEPOSITIONS, OR TESTIMONY

- **2000.** Advantel, LLC et al v. AT&T, *US District Court for the Eastern District of Virginia, Alexandria Division*. Provided deposition on behalf of CTSI regarding the appropriate level of interexchange access charges for CLEC traffic.
- **2004.** US LEC vs. ITC^DeltaCom, *US District Court for the Northern District of Georgia, Newnan Division*. Provided expert disclosure and testified on behalf of US LEC regarding tariff construction, interpretation, and the appropriate intercarrier compensation charges for wireless originated 800 calls.
- **2005.** 3 Rivers, et al vs. Qwest Corporation, *US District Court for the District of Montana, Great Falls Division*. Provided expert disclosure and deposition on behalf of Ronan Telephone Company and Hot Springs Telephone Company regarding the appropriate intercarrier compensation charges for certain traffic types.
- **2006.** US LEC vs. Qwest Communications Corporation, *US District Court for the Northern District of North Carolina, Charlotte Division*. Provided initial expert disclosure and an expert witness rebuttal report on damages on behalf of US LEC regarding tariff construction, interpretation, and the appropriate intercarrier compensation charges for wireless originated 800 calls.
- **2009.** Aventure Communications Technology vs. MCI Communications Services d/b/a Verizon Business Services, *US District Court for the Northern District of Iowa, Western Division*. Provided initial expert report on behalf of Aventure interpreting federal access charge rules, tariff structure, traffic routing and rating, and payment of marketing fees by telecommunications providers. Also calculated damages on behalf of Aventure.

RECEIVED
2011 AUG -1 PM 4:02
SECRETARY'S BUREAU

EXHIBIT GMZ-2



Solutions | Doing Business | Systems & Measures | Resources

Search

Site Map | Glossary | Calendar | Training | FAQs | Contact Us

Verizon Global Wholesale \ Doing Business \ Establish & Maintain Account

Access Tandem Connection

Doing Business

Local

[Establish & Maintain Account](#)

[Ordering](#)

[Provisioning](#)

[Trouble Admin](#)

[Billing](#)

Description

ATC is a standard interconnection under 251/252 described as follows:

- Available from class 4 and 4/5 access tandem offices
- Carries local, EAS, and/or non-presubscribed IntraLATA toll traffic
- Gives the Service Provider (SP) terminating access to the access tandem of interconnection and its subtending end offices
- Gives the Verizon access tandem and subtending end offices originating access to the SP's switching entity/interconnection point (IP)

Voice and data may be provisioned as one trunk group, if the switch resource is capable and available.

Note: During Interim Number Portability, the ATC may also carry Interexchange Carrier (IC) traffic terminating from ICs to Verizon numbers that are ported via the ATC interconnection to the SP's switching entity/IP. This is a temporary arrangement which will end when full Number Portability is implemented.

In an area where IntraLATA competition has not been implemented, the ATC may be used to inter-tandem switch as follows:

Inter-tandem switching for the transport and termination of traffic over the ATC will only be used if the SP has agreed to and fully implemented an existing IntraLATA toll compensation mechanism such as IntraLATA Access Compensation (ITAC) or a functional equivalent thereof, or at such time generally accepted industry signaling standards and AMA (Automatic Message Accounting) record standards support the recognition of multiple tandem switching events.

Other than as stated above, Verizon will not inter-tandem switch CLEC traffic.

Numbers

Although assignment of an NPA/NXX is not required for interconnection, if SPs wish to assign telephone numbers and receive calls at their switching entities, the SPs must obtain their own NXXs. The ATC will not utilize blocks of 100 numbers.

Facilities

ATC will be provisioned as follows:

- z As a two-way or two one-way facilities
- z With two-way combined, (local/EAS and IntraLATA toll), dedicated local/EAS, and/or dedicated IntraLATA toll trunks to ride the facility
- z SS7 signaling available where technically feasible
- z Typically at the DS1 level or DS3 if sufficient capacity requirements exist

If an SP has ordered one-way trunks to Verizon. Verizon is required to initiate an Access Service Request (ASR) to the SP for trunks from Verizon to the SP. Verizon is also required to *order trunks to the SP if the SP orders two-way trunks, but the trunks are only used one-way for interconnection.*

The SP can use its existing (IC) access facilities to establish local interconnection trunk groups. The flat-rated rates, therefore, would be switched access rates as determined by the applicable federal and state access tariffs. Note that Verizon's federal access tariffs do not require Verizon to proportionalize local traffic. Services purchased from access tariffs will be charged access rates. If the SP prefers to be charged the rates in the interconnection agreement, then the SP cannot use services purchased from the access tariff, i.e., use spare capacity which is already paid for under the access tariff. If the SP wants the rates from the agreement, then the SP must establish separate facilities for trunk groups.

Calling Scope

ATC gives terminating access from the SP's switching entity/IP to those end offices which subtend the access tandem of interconnection:

- z Both Verizon and non-end offices
- z Local and/or toll with respect to the SP's interconnection

Calls originating from end users within the Verizon access tandem/subtending end office complex will be completed to the NPA/NXXs served by the SP's switching entity/IP over the ATC.

Calls originating from the SP's switching entity/IP and attempting to access services such as operator or directory assistance are not routed via the ATC (See Auxiliary Interconnection). Likewise, IC traffic will not utilize the ATC except as previously noted for Verizon ported numbers in an Interim Number Portability environment (See IC Transit Interconnection). End offices that are EAS or toll to the serving wire center of the access tandem of interconnection but do not subtend the access tandem of interconnection are not part of the ATC calling scope.

Dial Plan

For call routing over the ATC, dialing patterns should conform to the North American Numbering Plan (NANP).

The SP must send Verizon sufficient digit information for call routing as follows:

- ⌚ Minimum of seven digits required on a direct dialed call
- ⌚ Seven or ten digits required for local/EAS calls, depending upon NPA/NXX configuration of the access tandem's subtending offices

For call completion to the SP's switching entity/IP, Verizon end users must dial:

- ⌚ A prefix (1+) in most areas plus a minimum of seven digits for direct dialed calls
- ⌚ Seven or ten digits for local/EAS calls, dependent upon NPA/NXX configuration of the access tandem's subtending offices

In general, Verizon will not prefix any additional digits to calls terminating to the SP's switching entity/IP, nor will Verizon delete or add any special digits.

Call Routing

- ⌚ SP calls terminating to end offices subtending the Verizon access tandem will:
 - route from the SP's switching entity/IP to the point of call termination at the Verizon access tandem over the ATC and be completed to the end user telephone number in the subtending end office
- ⌚ Calls originating from end offices subtending the Verizon access tandem will:
 - route to the SP's switching entity/IP over the ATC
- ⌚ Calls originating from the world to NXX's belonging to the SP will:
 - route to the access tandem Routing Point according to the LERG (Local Exchange Routing Guide) over an IC Transit, not via the ATC
- ⌚ Calls originating within the LATA but outside of the access tandem complex of interconnection will:
 - NOT route over the ATC

Compensation and Rating

Compensation will depend upon the type of call being completed, local or IntraLATA toll, and compensation is impacted by the terms and conditions of the agreement in place between Verizon and the SP.

Rating of calls carried over the ATC is determined by the Rate Center selected by the SP. SPs must adopt a Rate Center for each NPA/NXX served by their switching entity/IP, and the Rate Center must be located within the same LATA as the Routing Point of the interconnection. In selecting a Rate Center, the SP

adopts the Rate Center areas that have state commission approval for the ILEC and will assign whole NPA/NXX codes to each Rate Center. The SP may designate one location within each Rate Center as a Routing Point for the NPA/NXX associated with that Rate Center; or alternatively, the SP may designate a single location within one Rate Center to serve as the Routing Point for all NPA/NXXs associated with that Rate Center and with one or more other Rate Centers served by the SP within an existing Verizon exchange area and LATA.

Interconnection Facility

Compensation on the interconnection facility will be:

- From the applicable state access tariff

or

- Per specific terms outlined in the SP's interconnection agreement

In both cases, applicable charges apply. Verizon may discount any charges to the SP for Verizon's use of any two-way trunks riding the facility. Verizon and the SP will negotiate an initial factor representative of the proportionate share of the facilities. This factor is then updated quarterly or as otherwise agreed upon.

Switch Usage

Presently, Verizon does not jurisdictionalize terminating local/toll traffic. However, in general, usage between Verizon and SPs must be classified as local or toll for compensation.

The distinction between local/toll traffic is made by applying factors to the traffic. Verizon and the SPs agree upon initial factors which jurisdictionalize local/toll. Verizon and the SPs may initially agree to a Bill and Keep arrangement where local usage is assumed to be balanced, and there is no billing by either party for local usage. Studies are performed thereafter at intervals stated in the SP's interconnection agreement or as otherwise agreed upon to update the factors. When the traffic is no longer balanced, Verizon and the SP will compensate each other for the exchange of local traffic.

Transport and termination of IntraLATA toll carried over the ATC are charged in accordance with the agreement between Verizon and the SP based upon the switched access (IntraLATA) or negotiated rate.

The following are common billing scenarios that occur with ATC interconnection:

1. SP traffic to Verizon end user (local/EAS)

Verizon measures terminating usage from the SP to the Verizon access tandem. The SP's PLU (Percent Local Usage factor) separates the SP's local from toll traffic riding the ATC. For example, if Verizon measured 1000 MOU (Minutes of Use), and

the PLU was defined as 90%, the local usage would then be 900 MOU. The remaining 100 MOU would be classified as IntraLATA toll.

Verizon bills the SP:

- If *Bill and Keep*, no billing to the SP for the local MOU
- If not *Bill and Keep*, bill the negotiated rate

2. Verizon end user traffic to SP (local/EAS)

Verizon's PLU separates Verizon's local from toll traffic riding the ATC.

SP bills Verizon:

- If *Bill and Keep*, no billing to Verizon for the local MOU
- If not *Bill and Keep*, bill the negotiated rate

3. SP traffic to Verizon end user (IntraLATA toll)

Verizon records terminating traffic at the Verizon access tandem. The SP's PLU separates the SP's local from toll traffic riding the ATC.

Verizon bills SP:

- Verizon tariffed access rates

4. Verizon end user traffic to SP (IntraLATA toll)

Verizon's PLU separates Verizon's local from toll traffic riding the ATC.

SP bills Verizon:

- SP's tariffed access rate; if the SP does not have tariffed rates then a negotiated rate will be billed

5. Third party traffic to SP via Verizon access tandem (local/EAS/ IntraLATA toll)

Verizon bills: (See Note.)

- Transiting rate to the third party

6. SP traffic to third party via Verizon access tandem (local/EAS/ IntraLATA toll)

Verizon bills:

- Transiting rate to the SP

Note: Guidelines for third party billing are under development.

Example: Access Tandem Connection (ATC)

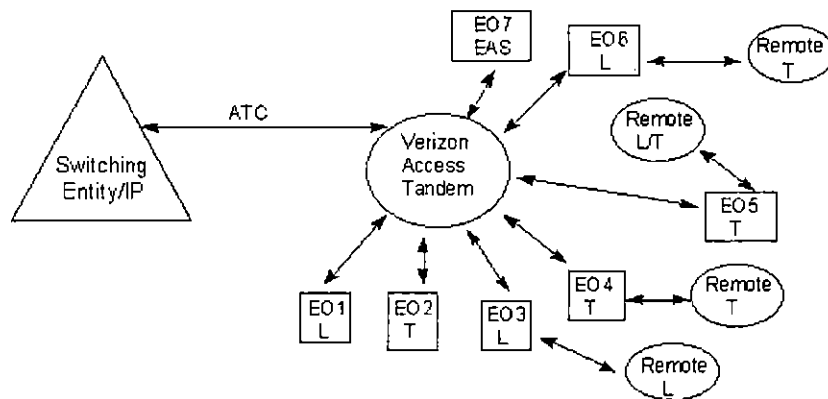

L=End Office Local to AT, Remote Local to AT or End Office
 T=End Office Toll to AT, Remote Toll to AT or End Office
 EAS=Extended Area Service to AT
 L/T=Remote Local to AT & Toll to Host End Office
 IP=Interconnection Point denotes the physical connection point of Verizon with the SP's switch or transmission facilities

Call Scope of ATC includes all end office and remote end offices shown.

RECEIVED

2011 AUG -1 PM 4:03

PA PUC
SECRETARY'S BUREAU

EXHIBIT GMZ-3

COMMERCIAL AGREEMENT

by and between

*****ILEC Full Name TXT*****

and

VERIZON PENNSYLVANIA, INC.

and

VERIZON NORTH, INC.

FOR THE COMMONWEALTH OF

PENNSYLVANIA

TABLE OF CONTENTS

COMMERCIAL AGREEMENT	1
1. The Agreement	1
2. Term and Termination.....	1
3. Glossary and Attachments.....	2
4. Applicable Law	2
5. Assignment.....	3
6. Assurance of Payment	3
7. Audits	4
8. Authorization	4
9. Billing and Payment; Disputed Amounts.....	5
10. Confidentiality	5
11. Counterparts.....	7
12. Default	7
13. [This Section Intentionally Left Blank].....	7
14. Dispute Resolution.....	7
15. Force Majeure	8
16. [This Section Intentionally Left Blank].....	8
17. Fraud	8
18. Good Faith Performance	8
19. Headings	9
20. Indemnification.....	9
21. [This Section Intentionally Left Blank].....	10
22. [This Section Intentionally Left Blank].....	10
23. Joint Work Product	10
24. Law Enforcement	10
25. Liability	11

26.	Network Management	12
27.	Non-Exclusive Remedies	12
28.	Notice of Network Changes	12
29.	Notices	12
30.	[This Section Intentionally Left Blank].....	13
31.	[This Section Intentionally Left Blank].....	13
32.	[This Section Intentionally Left Blank].....	13
33.	[This Section Intentionally Left Blank].....	13
34.	[This Section Intentionally Left Blank].....	13
35.	References	13
36.	Relationship of the Parties	14
37.	Reservation of Rights	14
38.	Subcontractors.....	14
39.	Successors and Assigns.....	14
40.	Survival	14
41.	Taxes	15
42.	Technology Upgrades.....	16
43.	Territory.....	17
44.	Third Party Beneficiaries	17
45.	[This Section Intentionally Left Blank].....	17
46.	[This Section Intentionally Left Blank].....	17
47.	[This Section Intentionally Left Blank].....	17
48.	Waiver.....	17
49.	Warranties.....	18
SIGNATURE PAGE.....		19
GLOSSARY		20
1.	General Rule	20
2.	Definitions.....	20

TANDEM TRANSIT TRAFFIC SERVICE ATTACHMENT.....	26
1. General	26
2. Pre-Existing ILEC to ILEC Interconnection Arrangements.....	26
3. [This Section Intentionally Left Blank].....	28
4. Traffic Measurement and Billing over Interconnection Trunks.....	28
5. [This Section Intentionally Left Blank].....	29
6. [This Section Intentionally Left Blank].....	29
7. [This Section Intentionally Left Blank].....	30
8. [This Section Intentionally Left Blank].....	30
9. [This Section Intentionally Left Blank].....	30
10. Tandem Transit Traffic	30
11. [This Section Intentionally Left Blank].....	30
12. Joint Network Implementation and Grooming Process; Forecasting	30
13. [This Section Intentionally Left Blank].....	31
14. [This Section Intentionally Left Blank].....	31
PRICING ATTACHMENT	32
1. General	32
2. Verizon Charges	32
3. ***ILEC Acronym TXT*** Charges.....	32
4. Regulatory Review of Prices.....	33
SCHEDULE XX.....	34

COMMERCIAL AGREEMENT

PREFACE

This Commercial Agreement ("Agreement") shall be deemed effective as of *****Date***** (the "Effective Date"), between *****ILEC Full Name TXT***** (*****ILEC Acronym TXT*****), a corporation organized under the laws of the Commonwealth of Pennsylvania, with offices at *****ILEC Address 1 TXT*****, *****ILEC City TXT*****, *****ILEC State MC***** *****ILEC Zip TXT***** and Verizon Pennsylvania and Verizon North (collectively "Verizon"), corporations organized under the laws of the *****Incorporation State-Commonwealth TXT***** and authorized to do business in the Commonwealth of Pennsylvania with offices at *****Verizon Address TXT*****, (Verizon and *****ILEC Acronym TXT***** may be referred to hereinafter, each, individually as a "Party", and, collectively, as the "Parties").

GENERAL TERMS AND CONDITIONS

In consideration of the mutual promises contained in this Agreement, and intending to be legally bound, Verizon and *****ILEC Acronym TXT***** hereby agree as follows:

1. The Agreement

- 1.1 This Agreement constitutes the entire agreement between the Parties on the subject matter hereof, and supersedes any prior or contemporaneous agreement, understanding, or representation, on the subject matter hereof. This Agreement however, is specifically limited to the provision of transit service for local traffic as defined in Section 2.31 and those items very specifically addressed herein. It is not intended to make other operational or functional changes in the operations, networking or financial responsibilities of the Parties except to the extent very specifically indicated. It is not intended to modify or otherwise alter any other agreements in place between the Parties, including inter alia any EAS arrangements or Exhibit 7 to the Telecommunications Services and Facilities Agreement ("TSFA").
- 1.2 Except as otherwise provided in this Agreement, the Agreement may not be waived or *modified except by a written document that is signed by the Parties.*
- 1.3 The Parties retain the right to use the services, including transit services, of any other provider for the duration of the Agreement.

2. Term and Termination

- 2.1 This Agreement shall be effective as of the Effective Date and, unless cancelled or terminated earlier in accordance with the terms hereof, shall continue in effect for three (3) years (the "Initial Term"). Thereafter, this Agreement shall continue in force and effect *unless and until cancelled or terminated as provided in this Agreement.*
- 2.2 Either *****ILEC Acronym TXT***** or Verizon may terminate this Agreement effective upon the expiration of the Initial Term or effective upon any date after expiration of the Initial Term by providing written notice of termination at least ninety (90) days in advance of the date of termination.
- 2.3 If either *****ILEC Acronym TXT***** or Verizon provides notice of termination pursuant to Section 2.2 and on or before the proposed date of termination either *****ILEC Acronym TXT***** or Verizon has requested negotiation of a replacement agreement, unless this Agreement is cancelled or terminated earlier in accordance with the terms hereof (including, but not limited to, pursuant to Section 12), this Agreement shall remain in effect until the earlier of: (a) the effective date of a replacement agreement between *****ILEC**

Acronym TXT*** and Verizon; or, (b) the date one (1) year after the proposed date of termination, provided that, if this Agreement is terminated by a Party pursuant to Section 2.2 and this Section 2:3(b), to the extent that either Party continues to use the Services being provided under this Agreement after such termination of this Agreement, such Services shall continue to be provided pursuant to the rates, terms and conditions of this Agreement.

- 2.4 If either ***ILEC Acronym TXT*** or Verizon provides notice of termination pursuant to Section 2.2 and by 11:59 PM Eastern Time on the proposed date of termination neither ***ILEC Acronym TXT*** nor Verizon has requested negotiation of a replacement agreement, (a) this Agreement will terminate at 11:59 PM Eastern Time on the proposed date of termination, and (b) to the extent that either Party continues to use the Services being provided under this Agreement after the termination of this Agreement, such Services shall continue to be provided pursuant to the rates, terms and conditions of this Agreement.

3. Glossary and Attachments

The Glossary and the following Attachments are a part of this Agreement:

Tandem Transit Traffic Service Attachment

Pricing Attachment

4. Applicable Law

- 4.1 The construction, interpretation and performance of this Agreement shall be governed by (a) the laws of the United States of America and (b) the laws of the Commonwealth of Pennsylvania, without regard to its conflicts of laws rules. All disputes relating to this Agreement shall be resolved through the application of such laws.
- 4.2 Each Party shall remain in compliance with Applicable Law in the course of performing this Agreement.
- 4.3 Neither Party shall be liable for any delay or failure in performance by it that results from requirements of Applicable Law, or acts or failures to act of any governmental entity or official.
- 4.4 Each Party shall promptly notify the other Party in writing of any governmental action that limits, suspends, cancels, withdraws, or otherwise materially affects, the notifying Party's ability to perform its obligations under this Agreement.
- 4.5 If any provision of this Agreement shall be invalid or unenforceable under Applicable Law, such invalidity or unenforceability shall not invalidate or render unenforceable any other provision of this Agreement, and this Agreement shall be construed as if it did not contain such invalid or unenforceable provision; provided, that if the invalid or unenforceable provision is a material provision of this Agreement, or the invalidity or unenforceability materially affects the rights or obligations of a Party hereunder or the ability of a Party to perform any material provision of this Agreement, the Parties shall promptly renegotiate in good faith and amend in writing this Agreement in order to make such mutually acceptable revisions to this Agreement as may be required in order to conform the Agreement to Applicable Law.
- 4.6 If any legislative, regulatory, judicial or other governmental decision, order, determination or action, or any change in Applicable Law, materially affects any material provision of this Agreement, the rights or obligations of a Party hereunder, or the ability of a Party to perform any material provision of this Agreement, the Parties shall promptly renegotiate in good faith and amend in writing this Agreement in order to make such mutually acceptable

revisions to this Agreement as may be required in order to conform the Agreement to Applicable Law. If within sixty (60) days of the effective date of such decision, determination, action or change, the Parties are unable to agree in writing upon mutually acceptable revisions to this Agreement, either Party may pursue any remedies available to it under this Agreement, at law, in equity, or otherwise, including, but not limited to, instituting an appropriate proceeding before the Commission, the FCC, or a court of competent jurisdiction, without first pursuing dispute resolution in accordance with Section 14 of this Agreement. If it is determined that ***ILEC Acronym TXT*** has no obligation to transport the traffic which is the subject of this Agreement, beyond the ***ILEC Acronym TXT***'s networks or borders, then ***ILEC Acronym TXT*** shall no longer be responsible for payment of any charges under this Agreement.

4.7 Each Party shall not provision services under this Agreement in a manner that will result in or permit the circumvention of intrastate or interstate access charges.

5. Assignment –

5.1 Neither Party may assign this Agreement or any right or interest under this Agreement, nor delegate any obligation under this Agreement, without the prior written consent of the other Party, which consent shall not be unreasonably withheld, conditioned or delayed. Any attempted assignment or delegation in violation of this Section 5 shall be void and ineffective and constitute default of this Agreement.

6. Assurance of Payment

6.1 Upon request by either Party ("requesting Party"), the other Party shall, at any time and from time to time, provide to the requesting Party adequate assurance of payment of amounts due (or to become due) to the other Party hereunder.

6.2 Assurance of payment of charges may be requested if the other Party (a) is at any time in default under Section 12 hereof, or (b) admits its inability to pay its debts as such debts become due, has commenced a voluntary case (or has had a case commenced against it) under the U.S. Bankruptcy Code or any other law relating to bankruptcy, insolvency, reorganization, winding-up, composition or adjustment of debts or the like, has made an assignment for the benefit of creditors or is subject to a receivership or similar proceeding.

6.3 Unless otherwise agreed by the Parties, the assurance of payment shall consist of an unconditional, irrevocable standby letter of credit naming the requesting Party as the beneficiary thereof and otherwise in form and substance satisfactory to the requesting Party from a financial institution acceptable to the requesting Party. The letter of credit shall be in an amount equal to two (2) months anticipated charges (including, but not limited to, both recurring and non-recurring charges), as reasonably determined by the requesting Party, for the Services to be provided by the requesting Party to the other Party in connection with this Agreement. If the other Party meets the condition in subsection 6.2 (b) above the requesting Party may, at its option, demand (and the other Party shall provide) additional assurance of payment, consisting of monthly advanced payments of estimated charges as reasonably determined by the requesting Party, with appropriate true-up against actual billed charges no more frequently than once per Calendar Quarter.

6.4 [Intentionally Left Blank].

6.5 [Intentionally Left Blank].

6.6 The requesting Party may (but is not obligated to) draw on the letter of credit upon notice to the other Party in respect of any amounts to be paid by the other Party hereunder that are not paid within thirty (30) days of the date that payment of such (undisputed) amounts is required by this Agreement.

- 6.7 If the requesting Party draws on the letter of credit, upon request by the requesting Party, the other Party shall provide a replacement or supplemental letter of credit conforming to the requirements of Section 6.3.
- 6.8 Notwithstanding anything else set forth in this Agreement, if requesting Party makes a request for assurance of payment in accordance with the terms of this Section, then the requesting Party shall have no obligation thereafter to perform under this Agreement until such time as the other Party has provided the requesting Party with such assurance of payment.
- 6.9 The fact that a letter of credit is requested hereunder shall in no way relieve the other Party from compliance with the requirements of this Agreement as to advance payments and payment for Services, nor constitute a waiver or modification of the terms herein pertaining to the discontinuance of Services for nonpayment of any amounts payment of which is required by this Agreement.

7. Audits

- 7.1 Either Party ("Auditing Party") may audit the other Party's ("Audited Party") books, records, documents, facilities and systems for the purpose of evaluating the accuracy of the Audited Party's bills. Except as may otherwise be specifically provided, such audits may be performed once in each Calendar Year; provided, however, that audits may be conducted more frequently (but no more frequently than once in each Calendar Quarter) if the immediately preceding audit found previously uncorrected net inaccuracies in billing in favor of the Audited Party having an aggregate value of at least \$100,000.
- 7.2 The audit shall be performed by individuals knowledgeable in the field selected and paid by the Auditing Party. The auditors shall be reasonably acceptable to the Audited Party. Prior to commencing the audit, the auditors shall execute an agreement with the Audited Party in a form reasonably acceptable to the Audited Party that protects the confidentiality of the information disclosed by the Audited Party to the accountants. The audit shall take place at a time and place agreed upon by the Parties; provided, that the Auditing Party may require that the audit commence no later than sixty (60) days after the Auditing Party has given notice of the audit to the Audited Party.
- 7.3 Each Party shall cooperate fully in any such audit, providing reasonable access to any and all employees, books, records, documents, facilities and systems, reasonably necessary to assess the accuracy of the Audited Party's bills.
- 7.4 Audits shall be performed at the Auditing Party's expense, provided that there shall be no charge for reasonable access to the Audited Party's employees, books, records, documents, facilities and systems necessary to assess the accuracy of the Audited Party's bills.

8. Authorization

- 8.1 Verizon represents and warrants that it is a corporation duly organized, validly existing and in good standing under the laws of the ***Incorporation State-Commonwealth TXT*** of ***Incorporation State TXT*** and has full power and authority to execute and deliver this Agreement and to perform its obligations under this Agreement.
- 8.2 ***ILEC Acronym TXT*** represents and warrants that it is a corporation duly organized, validly existing and in good standing under the laws of the ***ILEC Incorporation State-Commonwealth TXT*** of ***ILEC State of Incorporation MC***, and has full power and authority to execute and deliver this Agreement and to perform its obligations under this Agreement.

9. Billing and Payment; Disputed Amounts

- 9.1 Except as otherwise provided in this Agreement, each Party shall submit to the other Party on a monthly basis, statement(s) of charges incurred by the other Party under this Agreement.
- 9.2 Except as otherwise provided in this Agreement, payment of amounts billed for Services provided under this Agreement, whether billed on a monthly basis or as otherwise provided in this Agreement, shall be due, in immediately available U.S. funds, on the later of the following dates (the "Due Date"): (a) the due date specified on the billing Party's statement; or (b) twenty (20) days after the date the statement is received by the billed Party. Payments shall be transmitted by electronic funds transfer or check.
- 9.3 If any portion of an amount billed by a Party under this Agreement is subject to a good faith dispute between the Parties, the billed Party shall give notice to the billing Party of the amounts it disputes ("Disputed Amounts") and include in such notice the specific details and reasons for disputing each item. A Party may also dispute prospectively with a single notice a class of charges that it disputes. Notice of a dispute may be given by a Party at any time, either before or after an amount is paid, and a Party's payment of an amount shall not constitute a waiver of such Party's right to subsequently dispute its obligation to pay such amount or to seek a refund of any amount paid. The billed Party shall pay by the Due Date all undisputed amounts. Billing disputes shall be subject to the terms of Section 14, Dispute Resolution.
- 9.4 Charges due to the billing Party that are not paid by the Due Date shall be subject to a late payment charge. The late payment charge shall be in an amount specified by the billing Party which shall not exceed a rate equal to the lesser of: (a) one-and-one-half percent (1.5%) of the overdue amount (including any unpaid previously billed late payment charges) per month; or, (b) the maximum rate permitted by Applicable Law.
- 9.5 Although it is the intent of both Parties to submit timely statements of charges, failure by either Party to present statements to the other Party in a timely manner shall not constitute a breach or default, or a waiver of the right to payment of the incurred charges, by the billing Party under this Agreement, and, the billed Party shall not be entitled to dispute the billing Party's statement(s) based on the billing Party's failure to submit them in a timely fashion. Notwithstanding the preceding sentence of this Section 9.5, a Party (Providing Party) waives its right to payment of charges for Services provided by it to the other Party (Purchasing Party), if the Providing Party does not present a statement for these charges to the Purchasing Party within two (2) years after the Services were provided by the Providing Party.

10. Confidentiality

- 10.1 As used in this Section 10, "Confidential Information" means the following information that is disclosed by one Party ("Disclosing Party") to the other Party ("Receiving Party") in connection with, or anticipation of, this Agreement:
 - 10.1.1 Books, records, documents and other information disclosed in an audit pursuant to Section 7;
 - 10.1.2 Any forecasting information provided pursuant to this Agreement;
 - 10.1.3 Customer Information (except to the extent that (a) the Customer information is published in a directory, (b) the Customer information is disclosed through or in the course of furnishing a Telecommunications Service, such as directory assistance, operator service, Caller ID or similar service, or LIDB service, or (c)

the Customer to whom the Customer Information is related has authorized the Receiving Party to use and/or disclose the Customer Information);

- 10.1.4 information related to specific facilities or equipment (including, but not limited to, cable and pair information);
- 10.1.5 any information that is in written, graphic, electromagnetic, or other tangible form, and marked at the time of disclosure as "Confidential" or "Proprietary"; and
- 10.1.6 any information that is communicated orally or visually and declared to the Receiving Party at the time of disclosure, and by written notice with a statement of the information given to the Receiving Party within ten (10) days after disclosure, to be "Confidential" or "Proprietary".

Notwithstanding any other provision of this Agreement, a Party shall have the right to refuse to accept receipt of information which the other Party has identified as Confidential Information pursuant to Sections 10.1.5 or 10.1.6.

10.2 Except as otherwise provided in this Agreement, the Receiving Party shall:

- 10.2.1 use the Confidential Information received from the Disclosing Party only in performance of this Agreement; and
- 10.2.2 using the same degree of care that it uses with similar confidential information of its own (but in no case a degree of care that is less than commercially reasonable), hold Confidential Information received from the Disclosing Party in confidence and restrict disclosure of the Confidential Information solely to those of the Receiving Party's Affiliates and the directors, officers, employees, Agents and contractors of the Receiving Party and the Receiving Party's Affiliates, that have a need to receive such Confidential Information in order to perform the Receiving Party's obligations under this Agreement. The Receiving Party's Affiliates and the directors, officers, employees, Agents and contractors of the Receiving Party and the Receiving Party's Affiliates, shall be required by the Receiving Party to comply with the provisions of this Section 10 in the same manner as the Receiving Party. The Receiving Party shall be liable for any failure of the Receiving Party's Affiliates or the directors, officers, employees, Agents or contractors of the Receiving Party or the Receiving Party's Affiliates, to comply with the provisions of this Section 10.

10.3 The Receiving Party shall return or destroy all Confidential Information received from the Disclosing Party, including any copies made by the Receiving Party, within thirty (30) days after a written request by the Disclosing Party is delivered to the Receiving Party, except for (a) Confidential Information that the Receiving Party reasonably requires to perform its obligations under this Agreement, and (b) one copy for archival purposes only.

10.4 Unless otherwise agreed, the obligations of Sections 10.2 and 10.3 do not apply to information that:

- 10.4.1 was, at the time of receipt, already in the possession of or known to the Receiving Party free of any obligation of confidentiality and restriction on use;
- 10.4.2 is or becomes publicly available or known through no wrongful act of the Receiving Party, the Receiving Party's Affiliates, or the directors, officers, employees, Agents or contractors of the Receiving Party or the Receiving Party's Affiliates;

- 10.4.3 is rightfully received from a third person having no direct or indirect obligation of confidentiality or restriction on use to the Disclosing Party with respect to such information;
 - 10.4.4 is independently developed by the Receiving Party;
 - 10.4.5 is approved for disclosure or use by written authorization of the Disclosing Party (including, but not limited to, in this Agreement); or
 - 10.4.6 is required to be disclosed by the Receiving Party pursuant to Applicable Law, provided that the Receiving Party shall have made commercially reasonable efforts to give adequate notice of the requirement to the Disclosing Party in order to enable the Disclosing Party to seek protective arrangements.
- 10.5 Notwithstanding the provisions of Sections 10.1 through 10.4, the Receiving Party may use and disclose Confidential Information received from the Disclosing Party to the extent necessary to enforce the Receiving Party's rights under this Agreement or Applicable Law. In making any such disclosure, the Receiving Party shall make reasonable efforts to preserve the confidentiality and restrict the use of the Confidential Information while it is in the possession of any person to whom it is disclosed, including, but not limited to, by requesting any governmental entity to whom the Confidential Information is disclosed to treat it as confidential and restrict its use to purposes related to the proceeding pending before it.
- 10.6 The Disclosing Party shall retain all of the Disclosing Party's right, title and interest in any Confidential Information disclosed by the Disclosing Party to the Receiving Party.
- 10.7 The provisions of this Section 10 shall be in addition to and not in derogation of any provisions of Applicable Law and are not intended to constitute a waiver by a Party of any right with regard to the use, or protection of the confidentiality of, CPNI provided by Applicable Law.
- 10.8 Each Party's obligations under this Section 10 shall survive expiration, cancellation or termination of this Agreement.

11. Counterparts

This Agreement may be executed in two or more counterparts, each of which shall be deemed an original and all of which together shall constitute one and the same instrument.

12. Default

If either Party ("Defaulting Party") fails to make a payment required by this Agreement (including, but not limited to, any payment required by Section 9.3 of undisputed amounts to the billing Party) or materially breaches any other material provision of this Agreement, including but not limited to Section 4 of the Tandem Transit Traffic Service Attachment, and such failure or breach continues for thirty (30) days after written notice thereof from the other Party, the other Party may, by written notice to the Defaulting Party, (a) suspend the provision of any or all Services hereunder, or (b) cancel this Agreement and terminate the provision of all Services hereunder.

13. [This Section Intentionally Left Blank]

14. Dispute Resolution

14.1 Except as otherwise provided in this Agreement, any dispute between the Parties regarding the interpretation or enforcement of this Agreement or any of its terms shall be addressed by good faith negotiation between the Parties. To initiate such negotiation, a Party must provide to the other Party written notice of the dispute that includes both a

detailed description of the dispute or alleged nonperformance and the name of an individual who will serve as the initiating Party's representative in the negotiation. The other Party shall have ten Business Days to designate its own representative in the negotiation. The Parties' representatives shall meet at least once within 45 days after the date of the initiating Party's written notice in an attempt to reach a good faith resolution of the dispute. Upon agreement, the Parties' representatives may utilize other alternative dispute resolution procedures such as private mediation to assist in the negotiations.

- 14.2 If the Parties have been unable to resolve the dispute within 45 days of the date of the initiating Party's written notice, either Party may pursue any remedies available to it under this Agreement, at law, in equity, or otherwise, including, but not limited to, instituting an appropriate proceeding before the Commission, the FCC, or a court of competent jurisdiction.

15. Force Majeure

- 15.1 Neither Party shall be responsible for any delay or failure in performance which results from causes beyond its reasonable control ("Force Majeure Events"), whether or not foreseeable by such Party. Such Force Majeure Events include, but are not limited to, adverse weather conditions, flood, fire, explosion, earthquake, volcanic action, power failure, embargo, boycott, war, revolution, civil commotion, act of public enemies, labor unrest (including, but not limited to, strikes, work stoppages, slowdowns, picketing or boycotts), inability to obtain equipment, parts, software or repairs thereof, acts or omissions of the other Party, and acts of God.
- 15.2 If a Force Majeure Event occurs, the non-performing Party shall give prompt notification of its inability to perform to the other Party. During the period that the non-performing Party is unable to perform, the other Party shall also be excused from performance of its obligations to the extent such obligations are reciprocal to, or depend upon, the performance of the non-performing Party that has been prevented by the Force Majeure Event. The non-performing Party shall use commercially reasonable efforts to avoid or remove the cause(s) of its non-performance and both Parties shall proceed to perform once the cause(s) are removed or cease.
- 15.3 Notwithstanding the provisions of Sections 15.1 and 15.2, in no case shall a Force Majeure Event excuse either Party from an obligation to pay money for services rendered under this Agreement as required by this Agreement.
- 15.4 Nothing in this Agreement shall require the non-performing Party to settle any labor dispute except as the non-performing Party, in its sole discretion, determines appropriate.

16. [This Section Intentionally Left Blank]

17. Fraud

Each Party assumes responsibility for all fraud associated with its Customers and accounts. Neither Party shall bear responsibility for, and shall have no obligation to investigate or make adjustments to the Other Party's account in cases of, fraud by the other Party's Customers.

18. Good Faith Performance

The Parties shall act in good faith in their performance of this Agreement. Except as otherwise expressly stated in this Agreement (including, but not limited to, where consent, approval, agreement or a similar action is stated to be within a Party's sole discretion), where consent, approval, mutual agreement or a similar action is required by any provision of this Agreement, such action shall not be unreasonably withheld, conditioned or delayed.

19. Headings

The headings used in the Agreement are inserted for convenience of reference only and are not intended to be a part of or to affect the meaning of the Agreement.

20. Indemnification

20.1 Each Party ("Indemnifying Party") shall indemnify, defend and hold harmless the other Party ("Indemnified Party"), the Indemnified Party's Affiliates, and the directors, officers and employees of the Indemnified Party and the Indemnified Party's Affiliates, from and against any and all Claims that arise out of bodily injury to or death of any person, or damage to, or destruction or loss of, tangible real and/or personal property of any person, to the extent such injury, death, damage, destruction or loss, was proximately caused by the grossly negligent or intentionally wrongful acts or omissions of the Indemnifying Party, the Indemnifying Party's Affiliates, or the directors, officers, employees, Agents or contractors (excluding the Indemnified Party) of the Indemnifying Party or the Indemnifying Party's Affiliates, in connection with this Agreement.

20.2 Indemnification Process.

20.2.1 As used in this Section 20, "Indemnified Person" means a person whom an Indemnifying Party is obligated to indemnify, defend and/or hold harmless under Section 20.1.

20.2.2 An Indemnifying Party's obligations under Section 20.1 shall be conditioned upon the following:

20.2.3 The Indemnified Person: (a) shall give the Indemnifying Party notice of the Claim promptly after becoming aware thereof (including a statement of facts known to the Indemnified Person related to the Claim and an estimate of the amount thereof); (b) prior to taking any material action with respect to a Third Party Claim, shall consult with the Indemnifying Party as to the procedure to be followed in defending, settling, or compromising the Claim; (c) shall not consent to any settlement or compromise of a Third Party Claim without the written consent of the Indemnifying Party; (d) shall permit the Indemnifying Party to assume the defense of a Third Party Claim (including, except as provided below, the compromise or settlement thereof) at the Indemnifying Party's own cost and expense, provided, however, that the Indemnified Person shall have the right to reasonably approve the Indemnifying Party's choice of legal counsel.

20.2.4 If the Indemnified Person fails to comply with Section 20.2.3 with respect to a Claim, to the extent such failure shall have a material adverse effect upon the Indemnifying Party, the Indemnifying Party shall be relieved of its obligation to indemnify, defend and hold harmless the Indemnified Person with respect to such Claim under this Agreement.

20.2.5 Subject to 20.2.6 and 20.2.7, below, the Indemnifying Party shall have the authority to defend and settle any Third Party Claim.

20.2.6 With respect to any Third Party Claim, the Indemnified Person shall be entitled to participate with the Indemnifying Party in the defense of the Claim if the Claim requests equitable relief or other relief that could affect the rights of the Indemnified Person. In so participating, the Indemnified Person shall be entitled to employ separate counsel for the defense at the Indemnified Person's expense. The Indemnified Person shall also be entitled to participate, at its own expense, in the defense of any Claim, as to any portion of the Claim as to

which it is not entitled to be indemnified, defended and held harmless by the Indemnifying Party.

20.2.7 In no event shall the Indemnifying Party settle a Third Party Claim or consent to any judgment with regard to a Third Party Claim without the prior written consent of the Indemnified Party, which shall not be unreasonably withheld, conditioned or delayed. In the event the settlement or judgment requires a contribution from or affects the rights of an Indemnified Person, the Indemnified Person shall have the right to refuse such settlement or judgment with respect to itself and, at its own cost and expense, take over the defense against the Third Party Claim, provided that in such event the Indemnifying Party shall not be responsible for, nor shall it be obligated to indemnify or hold harmless the Indemnified Person against, the Third Party Claim for any amount in excess of such refused settlement or judgment.

20.2.8 The Indemnified Person shall, in all cases, assert any and all provisions in applicable Tariffs and Customer contracts that limit liability to third persons as a bar to, or limitation on, any recovery by a third-person claimant.

20.2.9 The Indemnifying Party and the Indemnified Person shall offer each other all reasonable cooperation and assistance in the defense of any Third Party Claim.

20.3 Each Party agrees that it will not implead or bring any action against the other Party, the other Party's Affiliates, or any of the directors, officers or employees of the other Party or the other Party's Affiliates, based on any claim by any person for personal injury or death that occurs in the course or scope of employment of such person by the other Party or the other Party's Affiliate and that arises out of performance of this Agreement.

20.4 Each Party's obligations under this Section 20 shall survive expiration, cancellation or termination of this Agreement.

21. [This Section Intentionally Left Blank]

22. [This Section Intentionally Left Blank]

23. Joint Work Product

The Agreement is the joint work product of the Parties, has been negotiated by the Parties, and shall be fairly interpreted in accordance with its terms. In the event of any ambiguities, no inferences shall be drawn against either Party.

24. Law Enforcement

24.1 Each Party may cooperate with law enforcement authorities and national security authorities to the full extent required or permitted by Applicable Law in matters related to Services provided by it under this Agreement, including, but not limited to, the production of records, the establishment of new lines or the installation of new services on an existing line in order to support law enforcement and/or national security operations, and, the installation of wiretaps, trap-and-trace facilities and equipment, and dialed number recording facilities and equipment.

24.2 A Party shall not have the obligation to inform the other Party or the Customers of the other Party of actions taken in cooperating with law enforcement or national security authorities, except to the extent required by Applicable Law.

24.3 Where a law enforcement or national security request relates to the establishment of lines (including, but not limited to, lines established to support interception of communications

on other lines), or the installation of other services, facilities or arrangements, a Party may act to prevent the other Party from obtaining access to information concerning such lines, services, facilities and arrangements.

25. Liability

- 25.1 As used in this Section 25, "Service Failure" means a failure to comply with a direction to install, restore or terminate Services under this Agreement, a failure to provide Services under this Agreement, and failures, mistakes, omissions, interruptions, delays, errors, defects or the like, occurring in the course of the provision of any Services under this Agreement.
- 25.2 Except as otherwise stated in Section 25.5, the liability, if any, of a Party, a Party's Affiliates, and the directors, officers and employees of a Party and a Party's Affiliates, to the other Party, the other Party's Customers, and to any other person, for Claims arising out of a Service Failure shall not exceed an amount equal to the pro rata applicable monthly charge for the Services that are subject to the Service Failure for the period in which such Service Failure occurs.
- 25.3 Except as otherwise stated in Section 25.5, a Party, a Party's Affiliates, and the directors, officers and employees of a Party and a Party's Affiliates, shall not be liable to the other Party, the other Party's Customers, or to any other person, in connection with this Agreement (including, but not limited to, in connection with a Service Failure or any breach, delay or failure in performance, of this Agreement) for special, indirect, incidental, consequential, reliance, exemplary, punitive, or like damages, including, but not limited to, damages for lost revenues, profits or savings, or other commercial or economic loss, even if the person whose liability is excluded by this Section has been advised of the possibility of such damages.
- 25.4 The limitations and exclusions of liability stated in Sections 25.1 through 25.3 shall apply regardless of the form of a claim or action, whether statutory, in contract, warranty, strict liability, tort (including, but not limited to, negligence of a Party), or otherwise.
- 25.5 Nothing contained in Sections 25.1 through 25.4 shall exclude or limit liability:
- 25.5.1 under Sections 20, Indemnification, or 41, Taxes
 - 25.5.2 for any obligation to indemnify, defend and/or hold harmless that a Party may have under this Agreement.
 - 25.5.3 for damages arising out of or resulting from bodily injury to or death of any person, or damage to, or destruction or loss of, tangible real and/or personal property of any person, or Toxic or Hazardous Substances, to the extent such damages are otherwise recoverable under Applicable Law;
 - 25.5.4 for a claim for infringement of any patent, copyright, trade name, trade mark, service mark, or other intellectual property interest;
 - 25.5.5 under Section 258 of the Act or any order of FCC or the Commission implementing Section 258; or
 - 25.5.6 under the financial incentive or remedy provisions of any service quality plan required by the FCC or the Commission.
- 25.6 In the event that the liability of a Party, a Party's Affiliate, or a director, officer or employee of a Party or a Party's Affiliate, is limited and/or excluded under both this Section 25 and a provision of an applicable Tariff, the liability of the Party or other person shall be limited to

the smaller of the amounts for which such Party or other person would be liable under this Section or the Tariff provision.

26. Network Management

26.1 The Parties will work cooperatively in a commercially reasonable manner to maintain a reliable network. ***ILEC Acronym TXT*** and Verizon will exchange appropriate information (e.g., network information, maintenance contact numbers, escalation procedures, and information required to comply with requirements of law enforcement and national security agencies) to achieve this desired reliability. In addition, the Parties will work cooperatively in a commercially reasonable manner to apply sound network management principles to alleviate or to prevent traffic congestion.

26.2 The Parties shall commit to and provide an assigned contact person, which shall serve as an account manager who is obligated to promptly address any and all issues between the Parties.

27. Non-Exclusive Remedies

Except as otherwise expressly provided in this Agreement, each of the remedies provided under this Agreement is cumulative and is in addition to any other remedies that may be available under this Agreement or at law or in equity.

28. Notice of Network Changes

If a Party makes a change in the information necessary for the transmission and routing of services using that Party's facilities or network, or any other change in its facilities or network that will materially affect the interoperability of its facilities or network with the other Party's facilities or network, the Party making the change shall provide notice of the change at least ninety (90) days in advance of such change, and shall use reasonable efforts, as commercially practicable, to publish such notice at least one hundred eighty (180) days in advance of the change; provided, however, that if an earlier publication of notice of a change is required by Applicable Law (including, but not limited to, 47 CFR 51.325 through 51.335) notice shall be given at the time required by Applicable Law.

29. Notices

29.1 Except as otherwise provided in this Agreement, notices given by one Party to the other Party under this Agreement:

29.1.1 shall be in writing;

29.1.2 shall be delivered (a) personally, (b) by express delivery service with next Business Day delivery, (c) by first class, certified or registered U.S. mail, postage prepaid, (d) by facsimile telecopy, with a copy delivered in accordance with (a), (b) or (c), preceding, or (e) email with receipt notification, with a copy delivered in accordance with (a), (b) or (c), preceding; and

29.1.3 shall be delivered to the following addresses of the Parties:

To ***ILEC Acronym TXT***:

To Verizon:

Director- Negotiations
Verizon Global Wholesale
600 Hidden Ridge
HQEWMNOTICES
Irving, TX 75038
Facsimile Number: (972) 719-1519
Internet Address: wmnotices@verizon.com

with a copy to:

Vice President and Deputy General Counsel
Verizon Global Wholesale
1320 North Court House Road
9th Floor
Arlington, VA 22201
Facsimile: (703) 351-3656

or to such other address as either Party shall designate by proper notice.

Notices will be deemed given as of the earlier of (a) where there is personal delivery of the notice, the date of actual receipt, (b) where the notice is sent via express delivery service for next Business Day delivery, the next Business Day after the notice is sent, (c) where the notice is sent via First Class U.S. Mail, three (3) Business Days after mailing, (d) where notice is sent via certified or registered U.S. mail, the date of receipt shown on the Postal Service receipt, (e) where the notice is sent via facsimile telecopy, if the notice is sent on a Business Day and before 5 PM in the time zone where it is received, on the date set forth on the telecopy confirmation, or if the notice is sent on a non-Business Day or if the notice is sent on or after 5 PM in the time zone where it is received, the next Business Day after the date set forth on the telecopy confirmation, and (f) where the notice is sent via email with receipt notification, the date of receipt shown on the receipt notification.

Each Party shall notify the other Party, by written notice pursuant to this Section 29, of any changes in the addresses or other contact information identified under Section 29.1.3. above.

30. [This Section Intentionally Left Blank]

31. [This Section Intentionally Left Blank]

32. [This Section Intentionally Left Blank]

33. [This Section Intentionally Left Blank]

34. [This Section Intentionally Left Blank]

35. References

35.1 All references to Sections, Appendices and Exhibits shall be deemed to be references to Sections, Appendices and Exhibits of this Agreement unless the context shall otherwise require.

35.2 Unless the context shall otherwise require, any reference to a Tariff, agreement, technical or other document (which applies to the both Parties and of which both Parties have notice) or provision of Applicable Law, is to such Tariff, agreement, document, or provision of Applicable Law, as amended and supplemented from time to time (and, in the case of a Tariff or provision of Applicable Law, to any successor Tariff or provision).

36 Relationship of the Parties

- 36.1 The relationship of the Parties under this Agreement shall be that of independent contractors and nothing herein shall be construed as creating any other relationship between the Parties.
- 36.2 Nothing contained in this Agreement shall make either Party the employee of the other, create a partnership, joint venture, or other similar relationship between the Parties, or grant to either Party a franchise, distributorship or similar interest.
- 36.3 Nothing in this Agreement shall constitute a Party as a legal representative or Agent of the other Party, nor shall a Party have the right or authority to assume, create or incur any liability or any obligation of any kind, express or implied, against, in the name or on behalf of the other Party unless otherwise expressly permitted by such other Party in writing, which permission may be granted or withheld by the other Party in its sole discretion.
- 36.4 Each Party shall have sole authority and responsibility to hire, fire, compensate, supervise, and otherwise control its employees, Agents and contractors. Each Party shall be solely responsible for payment of any Social Security or other taxes that it is required by Applicable Law to pay in conjunction with its employees, Agents and contractors, and for withholding and remitting to the applicable taxing authorities any taxes that it is required by Applicable Law to collect from its employees.
- 36.5 Except as otherwise expressly provided in this Agreement, no Party undertakes to perform any obligation of the other Party, whether regulatory or contractual, or to assume any responsibility for the management of the other Party's business.
- 36.6 The relationship of the Parties under this Agreement is a non-exclusive relationship.

37. Reservation of Rights

Nothing in this Agreement shall be deemed to limit or prejudice any position a Party has taken or may take before the Commission, the FCC, any other state or federal regulatory or legislative bodies, courts of applicable jurisdiction, or industry fora. The provisions of this Section shall survive the expiration, cancellation or termination of this Agreement.

38. Subcontractors

A Party may use a contractor of the Party (including, but not limited to, an Affiliate of the Party) to perform the Party's obligations under this Agreement; provided, that a Party's use of a contractor shall not release the Party from any duty or liability to fulfill the Party's obligations under this Agreement.

39. Successors and Assigns

This Agreement shall be binding on and inure to the benefit of the Parties and their respective legal successors and permitted assigns.

40. Survival

The rights, liabilities and obligations of a Party for acts or omissions occurring prior to the expiration, cancellation or termination of this Agreement, the rights, liabilities and obligations of a Party under any provision of this Agreement regarding confidential information (including, but not limited to, Section 10), indemnification or defense (including, but not limited to, Section 20), or limitation or exclusion of liability (including, but not limited to, Section 25), and the rights, liabilities and obligations of a Party under any provision of this Agreement which by its terms or nature is intended to continue beyond or to be performed after the expiration, cancellation or termination of this Agreement, shall survive the expiration, cancellation or termination of this Agreement.

41. Taxes

- 41.1 In General. With respect to any purchase of Services under this Agreement, if any federal, state or local tax, fee, surcharge or other tax-like charge, excluding any tax levied on property or net income, (a "Tax") is required by Applicable Law or a Tariff to be collected from the Purchasing Party by the Providing Party, then (a) the Providing Party shall bill the Purchasing Party for such Tax, as a separately stated item on the invoice, (b) the Purchasing Party shall timely remit such Tax to the Providing Party and (c) the Providing Party shall timely remit such collected Tax to the applicable taxing authority as and to the extent required by Applicable Law.
- 41.2 Taxes Imposed on the Providing Party or Receipts. With respect to any purchase of Services under this Agreement, if any federal, state or local Tax is imposed by Applicable Law on the receipts of the Providing Party, and such Applicable Law specifically permits the Providing Party to exclude certain receipts received from sales to a public utility, distributor, telephone company, local exchange carrier, telecommunications company or other communications company ("Telecommunications Company"), such exclusion being based on the fact that the Purchasing Party is also subject to a tax based upon receipts ("Receipts Tax"), then the Purchasing Party shall pay and remit the Receipts Tax as required by Applicable Law.
- 41.3 Taxes Imposed on Subscriber. With respect to any purchase of Services under this Agreement that are resold to a third party, if any federal, state or local Tax is imposed by Applicable Law on the subscriber, end-user, customer or ultimate consumer ("Subscriber") in connection with any such purchase, which a Telecommunications Company is required to impose and/or collect from a Subscriber, or if any federal, state or local Tax is imposed on the Providing Party and required by Applicable Law to be passed through to the Subscriber, then the Purchasing Party (a) shall impose and/or collect such Tax from the Subscriber and (b) shall timely remit such Tax to the applicable taxing authority.
- 41.4 Tax Exemptions and Exemption Certificates. If Applicable Law clearly exempts a purchase hereunder from a Tax, and if such Applicable Law also provides an exemption procedure, such as an exemption certificate requirement, then, if the Purchasing Party complies with such procedure, the Providing Party shall not collect such Tax during the effective period of such exemption. Such exemption shall be effective upon receipt of the exemption certificate or affidavit in accordance with the terms set forth in Section 41.7. If Applicable Law clearly exempts a purchase hereunder from a Tax, but does not also provide an exemption procedure, then the Providing Party shall not collect such Tax if the Purchasing Party (a) furnishes the Providing Party with a letter signed by an officer requesting such an exemption and citing the provision in the Applicable Law which clearly allows such exemption and (b) supplies the Providing Party with an indemnification agreement, acceptable to the Providing Party, which holds the Providing Party harmless on an after-tax basis with respect to its forbearing to collect such Tax.
- 41.5 Liability for Uncollected Tax, Interest and Penalty
- 41.5.1 If the Providing Party has not received an exemption certificate from the Purchasing Party and the Providing Party fails to bill the Purchasing Party for any Tax as required by Section 41.1, then, as between the Providing Party and the Purchasing Party, (a) the Purchasing Party shall remain liable for such unbilled Tax and any interest assessed thereon and (b) the Providing Party shall be liable for any penalty assessed with respect to such unbilled Tax by a taxing authority.
- 41.5.2 If the Providing Party properly bills the Purchasing Party for any Tax but the Purchasing Party fails to remit such Tax to the Providing Party as required by Section 41.2, then, as between the Providing Party and the Purchasing Party, the

Purchasing Party shall be liable for such uncollected Tax and any interest assessed thereon, as well as any penalty assessed with respect to such uncollected Tax by the applicable taxing authority.

41.5.3 If the Providing Party does not collect any Tax as required by Section 41.1 because the Purchasing Party has provided such Providing Party with an exemption certificate that is later found to be inadequate, invalid or inapplicable by a taxing authority, then, as between the Providing Party and the Purchasing Party, the Purchasing Party shall be liable for such uncollected Tax and any interest assessed thereon, as well as any penalty assessed with respect to such uncollected Tax by the applicable taxing authority.

41.5.4 If the Purchasing Party fails to pay the Receipts Tax as required by Section 41.2, then, as between the Providing Party and the Purchasing Party, (a) the Providing Party shall be liable for any Tax imposed on its receipts and (b) the Purchasing Party shall be liable for any interest assessed thereon and any penalty assessed upon the Providing Party with respect to such Tax by the applicable taxing authority

41.5.6 If the Purchasing Party fails to impose and/or collect any Tax from Subscribers as required by Section 41.3, then, as between the Providing Party and the Purchasing Party, the Purchasing Party shall remain liable for such uncollected Tax and any interest assessed thereon, as well as any penalty assessed with respect to such uncollected Tax by the applicable taxing authority. With respect to any Tax that the Purchasing Party has agreed to pay, or is required to impose on and/or collect from Subscribers, the Purchasing Party agrees to indemnify and hold the Providing Party harmless on an after-tax basis for any costs incurred by the Providing Party as a result of actions taken by the applicable taxing authority to recover the Tax from the Providing Party due to the failure of the Purchasing Party to timely pay, or collect and timely remit, such Tax to such authority.

41.6 Audit Cooperation. In the event either Party is audited by a taxing authority, the other Party agrees to cooperate fully with the Party being audited in order to respond to any audit inquiries in a proper and timely manner so that the audit and/or any resulting controversy may be resolved expeditiously.

41.7 Notices. All notices, affidavits, exemption-certificates or other communications required or permitted to be given by either Party to the other, for purposes of this Section 41, shall be made in writing and shall be delivered in person or sent by certified mail, return receipt requested, or registered mail, or a courier service providing proof of service, and sent to the addressees set forth in Section 29 as well as to the following:

To Verizon: Verizon Communications
Tax Department
One Verizon Way, VC53S-221
Basking Ridge, NJ 07920

To ***ILEC Acronym TXT***:

ILEC Tax Notification Contact TXT

Each Party may from time to time designate another address or other addressees by giving notice in accordance with the terms of this Section. Any notice or other communication shall be deemed to be given when received.

42. Technology Upgrades

Nothing in this Agreement shall limit a Party's right to deploy, modify, upgrade, migrate and/or maintain its network at its discretion, including, but not limited to, through the incorporation of new equipment or software into its network. As new technologies evolve, the Parties, if they choose to implement these new technologies, will work to integrate the new technologies into the respective operations under this Agreement without the need to modify or revise the terms hereof.

43. Territory

43.1 This Agreement applies to the exchange of applicable traffic between the territory in which Verizon operates as an Incumbent Local Exchange Carrier in the Commonwealth of Pennsylvania and the territory in which ***ILEC Acronym TXT*** operates as an Incumbent Local Exchange Carrier in the Commonwealth of Pennsylvania. Verizon shall be obligated to provide Services under this Agreement only within the territory in which Verizon operates as an Incumbent Local Exchange Carrier in the Commonwealth of Pennsylvania. ***ILEC Acronym TXT*** shall be obligated to provide Services under this Agreement only within the territory in which ***ILEC Acronym TXT*** operates as an Incumbent Local Exchange Carrier in the Commonwealth of Pennsylvania.

43.2 Notwithstanding any other provision of this Agreement, Verizon may terminate this Agreement as to a specific operating territory or portion thereof if Verizon sells or otherwise transfers its operations in such territory or portion thereof to a third-person. Verizon shall provide ***ILEC Acronym TXT*** with at least 90 calendar days prior written notice of such termination, which shall be effective upon the date specified in the notice.

43.3 Notwithstanding any other provision of this Agreement, ***ILEC Acronym TXT*** may terminate this Agreement as to a specific operating territory or portion thereof if ***ILEC Acronym TXT*** sells or otherwise transfers its operations in such territory or portion thereof to a third-person. ***ILEC Acronym TXT*** shall provide Verizon with at least 90 calendar days prior written notice of such termination, which shall be effective upon the date specified in the notice.

44. Third Party Beneficiaries

Except as expressly set forth in this Agreement, this Agreement is for the sole benefit of the Parties and their permitted assigns, and nothing herein shall create or be construed to provide any third-persons (including, but not limited to, Customers, contractors of a Party or third party carriers) with any rights (including, but not limited to, any third-party beneficiary rights) hereunder. Except as expressly set forth in this Agreement, a Party shall have no liability under this Agreement to the Customers of the other Party or to any other third person.

45. [This Section Intentionally Left Blank]

46. [This Section Intentionally Left Blank]

47. Use of Service

Each Party shall make commercially reasonable efforts to ensure that its Customers comply with the provisions of this Agreement applicable to the use of Services purchased by it under this Agreement.

48. Waiver

A failure or delay of either Party to enforce any of the provisions of this Agreement, or any right or remedy available under this Agreement or at law or in equity, or to require performance of any of the provisions of this Agreement, or to exercise any option which is provided under this Agreement, shall in no way be construed to be a waiver of such provisions, rights, remedies or options.

49. Warranties

EXCEPT AS EXPRESSLY STATED IN THIS AGREEMENT, NEITHER PARTY MAKES OR RECEIVES ANY WARRANTY, EXPRESS OR IMPLIED, WITH RESPECT TO THE SERVICES PROVIDED, OR TO BE PROVIDED, UNDER THIS AGREEMENT AND THE PARTIES DISCLAIM ANY OTHER WARRANTIES, INCLUDING BUT NOT LIMITED TO, WARRANTIES OF MERCHANTABILITY, WARRANTIES OF FITNESS FOR A PARTICULAR PURPOSE WARRANTIES AGAINST INFRINGEMENT, AND WARRANTIES ARISING BY TRADE CUSTOM, TRADE USAGE, COURSE OF DEALING OR PERFORMANCE, OR OTHERWISE.

SIGNATURE PAGE

IN WITNESS WHEREOF, the Parties hereto have caused this Agreement to be executed as of the Effective Date.

*****ILEC Full Name TXT*****

VERIZON*IF Verizon Company Full Name 2 TXT
!= *******

By: _____

By: _____

Printed: *****ILEC Signing Party TXT*****

Printed: *****Verizon Signing Party's Name MC*****

Title: *****ILEC Signing Party's Title TXT*****

Title: *****Verizon Signing Party's Title MC*****

Date: _____

Date: _____

GLOSSARY

1. General Rule

- 1.1 *The provisions of Sections 1.2 through 1.4 and Section 2 apply with regard to the Agreement.*
- 1.2 Unless the context clearly indicates otherwise, when a term listed in this Glossary is used in the Agreement, the term shall have the meaning stated in this Glossary. A defined term intended to convey the meaning stated in this Glossary is capitalized when used. Other terms that are capitalized, and not defined in this Glossary or elsewhere in the Agreement, shall have the meaning stated in the Act. Additional definitions that are specific to the matters covered in a particular provision of the Agreement may appear in that provision. To the extent that there may be any conflict between a definition set forth in this Glossary and any definition in a specific provision, the definition set forth in the specific provision shall control with respect to that provision.
- 1.3 Unless the context clearly indicates otherwise, any term defined in this Glossary which is defined or used in the singular shall include the plural, and any term defined in this Glossary which is defined or used in the plural shall include the singular.
- 1.4 The words "shall" and "will" are used interchangeably throughout the Agreement and the use of either indicates a mandatory requirement. The use of one or the other shall not confer a different degree of right or obligation for either Party.

2. Definitions

- 2.1 Act.

The Communications Act of 1934 (47 U.S.C. §151 et seq.), as from time to time amended (including, but not limited to, by the Telecommunications Act of 1996).
- 2.2 Affiliate.

Shall have the meaning set forth in the Act.
- 2.3 Agent.

An agent or servant.
- 2.4 Ancillary Traffic.

All traffic that is destined for ancillary services, or that may have special billing requirements, including but not limited to the following: directory assistance, 911/E911, operator services (IntraLATA call completion), IntraLATA third party, collect and calling card, 800/888 database query and LIDB.
- 2.5 Applicable Law.

All effective laws, government regulations and government orders, applicable to each Party's performance of its obligations under this Agreement.
- 2.6 ATIS.

Alliance for Telecommunications Industry Solutions.

- 2.7 Business Day.
Monday through Friday, except for Federal holidays.
- 2.8 Calendar Quarter.
January through March, April through June, July through September, or October through December.
- 2.9 Calendar Year.
January through December.
- 2.10 CCS (Common Channel Signaling).
A method of transmitting call set-up and network control data over a digital signaling network separate from the public switched telephone network facilities that carry the actual voice or data content of the call.
- 2.11 Central Office.
An End Office or Tandem. Sometimes this term is used to refer to a telephone company building in which switching systems and telephone equipment are installed.
- 2.12 Claims.
Any and all claims, demands, suits, actions, settlements, judgments, fines, penalties, liabilities, injuries, damages, losses, costs (including, but not limited to, court costs), and expenses (including, but not limited to, reasonable attorney's fees).
- 2.13 CLEC (Competitive Local Exchange Carrier).
Any Local Exchange Carrier other than Verizon that is operating as a Local Exchange Carrier in the territory in which Verizon operates as an ILEC in the Commonwealth of Pennsylvania or any Local Exchange Carrier other than ***ILEC Acronym TXT*** that is operating as a Local Exchange Carrier in the territory in which ***ILEC Acronym TXT*** operates as an ILEC in the State/Commonwealth of [State].
- 2.14 Commission.
The Pennsylvania Public Utility Commission.
- 2.15 CPN (Calling Party Number).
A CCS parameter that identifies the calling party's telephone number.
- 2.16 CPNI (Customer Proprietary Network Information).
Shall have the meaning set forth in Section 222 of the Act, 47 U.S.C. § 222.
- 2.17 Customer or End User.
A third party residence or business end-user subscriber to Telephone Exchange Services provided by either of the Parties or a Third Party provider of Telecommunications Service

2.18 EMI (Exchange Message Interface).

Standard used for the interexchange of telecommunications message information between local exchange carriers and interexchange carriers for billable, non-billable, sample, settlement and study data. Data is provided between companies via a unique record layout that contains Customer billing information, account summary and tracking analysis. EMI format is contained in document SR-320 published by ATIS.

2.19 End Office.

A switching entity that is used for connecting lines to lines or lines to trunks for the purpose of originating/terminating calls. Sometimes this term is used to refer to a telephone company building in which switching systems and telephone equipment are installed.

2.20 Exchange Area Boundary (EAB) Arrangement.

An interconnection arrangement whereby the transmission facilities of Verizon and ***ILEC Acronym TXT*** meet at a mutually agreed-upon location at the franchise territory boundary where Verizon and ***ILEC Acronym TXT*** have separate but contiguous service territories. An EAB arrangement is subject to technical feasibility and the availability of facilities, except where such facilities are in place on the Effective Date hereof.

2.21 Exchange Access.

Shall have the meaning set forth in the Act.

2.22 Extended Local Calling Scope Arrangement.

An arrangement that provides a Customer a local calling scope (Extended Area Service, "EAS"), outside of the Customer's basic exchange serving area. Extended Local Calling Scope Arrangements may be either optional or non-optional. "Optional Extended Local Calling Scope Arrangement Traffic" is traffic that under an optional Extended Local Calling Scope Arrangement chosen by the Customer terminates outside of the Customer's basic exchange serving area. ***ILEC Acronym TXT***'s non-optional Extended Local Calling Scope Arrangements, provide End Users physically located in a specific local service exchange (Rate Center Area) the ability to place and receive calls to End Users physically located in another mutually exclusive specific local service exchange area (Rate Center Area) on the basis of terms, conditions and charges that are distinct from terms applicable to Toll Service, as provided in ***ILEC Acronym TXT*** Tariff, and as currently exist are listed in Schedule XX. Verizon's non-optional Extended Local Calling Scope Arrangements, provide End Users physically located in a specific local service exchange (Rate Center Area) the ability to place and receive calls to End Users physically located in another mutually exclusive specific local service exchange area (Rate Center Area) on the basis of terms, conditions and charges that are distinct from terms applicable to Toll Service, as provided in Verizon's Tariff, and as currently exist are listed in Schedule YY.

2.23 FCC.

The Federal Communications Commission.

2.24 ILEC (Incumbent Local Exchange Carrier).

Shall have the meaning stated in the Act. Verizon and ***ILEC Acronym TXT*** are ILECs.

- 2.25 Interexchange Traffic – Traffic that originates or terminates outside the local calling area and is not Local Traffic as measured by the physical geographic location of the calling and called End Users. Interexchange Traffic is specifically not subject to the transit charges specific herein.
- 2.26 Internet Traffic.
Any traffic that is transmitted to or returned from the Internet at any point during the duration of the transmission.
- 2.27 InterLATA Service.
Shall have the meaning set forth in the Act.
- 2.28 IntraLATA.
Telecommunications that originate and terminate within the same LATA.
- 2.29 LATA (Local Access and Transport Area).
Shall have the meaning set forth in the Act.
- 2.30 LEC (Local Exchange Carrier).
Shall have the meaning set forth in the Act.
- 2.31 Local Traffic - Traffic where the originating End User and the terminating End User are both physically located within the local calling area or non-optional extended local calling scope area. Local Traffic specifically excludes: (1) any Internet Traffic; (2) traffic that does not originate and terminate within the non-optional Extended Local Calling Scope Arrangement, based upon the actual originating and terminating points of the complete end- to end communications; (3)Toll/Interexchange Traffic; (4) Optional Extended Local Calling Scope Arrangement traffic; (5) Special Access, private line, Frame Relay, ATM, or any other traffic that is not switched by the terminating Party; (6) Voice Information Service Traffic; (7) Virtual NXX Traffic; or (8) Remote call forwarded traffic.
- 2.32 Measured Internet Traffic.
Dial-up, switched Internet Traffic originated by a Customer of one Party on that Party's network at a point in a local calling area set forth in Schedule XX, and delivered to a Customer or an Internet Service Provider served by the other Party, on that other Party's network at a point in the same local calling area set forth in Schedule XX. For the purposes of this definition, a local calling area set forth in Schedule XX includes a non-optional Extended Local Calling Scope Arrangement, but does not include an optional Extended Local Calling Scope Arrangement. Calls originated on a 1+ presubscription basis, or on a casual dialed (10XXX/101XXXX) basis, are not considered Measured Internet Traffic.
- 2.33 Providing Party.
A Party offering or providing a Service to the other Party under this Agreement.
- 2.34 Purchasing Party.
A Party requesting or receiving a Service from the other Party under this Agreement.

- 2.35 Rate Center Area – The Rate Center Area is the exclusive geographic area that the local exchange carrier has identified as the area within which it will provide local telephone service.
- 2.36 Service.
Any Interconnection arrangement, Telecommunications Service, or other service, facility or arrangement, offered by a Party under this Agreement.
- 2.37 SS7 (Signaling System 7).
The common channel out-of-band signaling protocol developed by the Consultative Committee for International Telephone and Telegraph (CCITT) and the American National Standards Institute (ANSI). Verizon and ***ILEC Acronym TXT*** currently utilize this out-of-band signaling protocol.
- 2.38 Switched Exchange Access Service.
The offering of transmission and switching services for the purpose of the origination or termination of Toll Traffic. Switched Exchange Access Services include but may not be limited to: Feature Group A, Feature Group B, Feature Group D, 700 access, 800 access, 888 access and 900 access.
- 2.39 Tandem.
A switching entity that has billing and recording capabilities and is used to connect and switch trunk circuits between and among End Offices and between and among End Offices and carriers' aggregation points, points of termination, or points of presence, and to provide Switched Exchange Access Services. Sometimes this term is used to refer to a telephone company building in which switching systems and telephone equipment are installed.
- 2.40 Tandem Transit Traffic – For purposes of this Agreement Tandem Transit Traffic is only Local Tandem Transit Traffic which is that Local Traffic as defined herein that originates on one Party's network and is transported through the other Party's tandem or End Office to the subtending End Office or its equivalent of another carrier (CLEC, ILEC – other than a Party hereto, Commercial Radio Service Carrier (CMRS) or other LEC ("Other Carrier")) Local Tandem Transit Traffic specifically does not include traffic terminating to Other Carrier's network, where Other Carrier utilizes the transiting Party's switching to provide its End User service (i.e. platform service and local resale. Switched Exchange Access Service Traffic is not Local Tandem Transit Service
- 2.41 Tariff.
2.41.1 Any applicable Federal or state tariff of a Party, as amended from time to time; or
2.41.2 Any standard agreement or other document, as amended from time to time, that sets forth the generally available terms, conditions and prices under which a Party offers a Service.
The term "Tariff" does not include any Verizon Statement of Generally Available Terms (SGAT) which has been approved or is pending approval by the Commission pursuant to Section 252(f) of the Act.
- 2.42 Telcordia Technologies.

Telcordia Technologies, Inc., formerly known as Bell Communications Research, Inc. (Bellcore).

2.43 Telecommunications Carrier.

Shall have the meaning set forth in the Act.

2.44 Telecommunications Services.

Shall have the meaning set forth in the Act.

2.45 Telephone Exchange Service.

Shall have the meaning set forth in the Act. However, for the purpose of this Agreement, it is more particularly limited to and defined as Local Traffic or Local Tandem Transit Traffic as defined herein and the more particular definition shall apply.

2.46 Third Party Claim.

A Claim where there is (a) a claim, demand, suit or action by a person who is not a Party, (b) a settlement with, judgment by, or liability to, a person who is not a Party, or (c) a fine or penalty imposed by a person who is not a Party.

2.47 Toll Traffic.

Traffic that is originated by a Customer of one Party on that Party's network and terminates to a Customer of the other Party on that other Party's network and is not Non-Optional Extended Local Calling Scope Arrangement Traffic, Measured Internet Traffic, or Ancillary Traffic. Toll Traffic may be either "IntraLATA Toll Traffic" or "InterLATA Toll Traffic", depending on whether the originating and terminating points are within the same LATA.

2.48 Virtual NXX Traffic.

VNXX Traffic is defined as calls in which an End User is assigned a telephone number with an NXX Code (as set forth in the LERG) assigned to a Rate Center Area that is different from the Rate Center Area associated with the End User's actual physical geographic location.

TANDEM TRANSIT TRAFFIC SERVICE ATTACHMENT

1. General

The Parties acknowledge that prior to the Effective Date they have established interconnection at a mutually agreed upon location at the franchise territory boundary employed by Verizon and ***ILEC Acronym TXT*** pursuant to an Exchange Area Boundary Arrangement ("EAB Location") to which the Parties mutually agree under the terms of this Agreement, for the transmission and routing of Tandem Transit Traffic Service.

2. Pre-Existing ILEC to ILEC Interconnection Arrangements

2.1 EAB Location(s).

2.1.1 Each Party, at its own expense, has provided transport facilities to the EAB Location(s). If the Parties desire alternative interconnection arrangements, such alternative arrangements shall be subject to written mutual agreement by the Parties and the applicable provisions of this Agreement (as amended from time-to-time) and any other written agreements between the Parties (such as a Telecommunications Services and Facilities Agreement,) (as amended from time-to-time).

2.2 Trunking .

2.2.1 The Parties have established various trunk groups under their pre-existing interconnection arrangements, under which the Parties provide services, including the transit service which is the subject hereof. (" Interconnection Trunks") Any new trunk groups necessitated by the provision of services hereunder shall be on terms to which both Parties mutually agree.

2.3 One-Way Interconnection Trunks.

2.3.1 Where the Parties use One-Way Interconnection Trunks for the delivery of traffic from ***ILEC Acronym TXT*** to Verizon, ***ILEC Acronym TXT***, at ***ILEC Acronym TXT***'s own expense, shall:

2.3.1.1 provide its own facilities for delivery of the traffic to the EAB Location(s) and/or

2.3.1.2 obtain transport for delivery of the traffic to the EAB Location(s) from a third party.

2.3.2 Where the Parties use One-Way Interconnection Trunks for the delivery of traffic from Verizon to ***ILEC Acronym TXT***, Verizon, at Verizon's own expense, shall:

2.3.2.1 provide its own facilities for delivery of the traffic to the EAB Location(s) and/or

2.3.2.2 obtain transport for delivery of the traffic to the EAB Location(s) from a third party.

2.3.3 For each Tandem or End Office One-Way Interconnection Trunk group for delivery of traffic from ***ILEC Acronym TXT*** to Verizon with a utilization level of less than sixty percent (60%) for final trunk groups and eighty-five percent (85%) for high usage trunk groups, unless the Parties agree otherwise,

ILEC Acronym TXT will promptly submit an appropriate order document to disconnect a sufficient number of Interconnection Trunks to attain a utilization level of approximately sixty percent (60%) for all final trunk groups and eight-five (85%) for all high usage trunk groups.

2.3.4 Since the Parties have a longstanding traffic history, on an as needed basis but no less frequently than semi-annually, the Parties shall meet and provide to each other a good faith trunk forecast of the number of One-Way Interconnection Trunks that will be needed during the ensuing two (2) year period for the exchange of traffic between ***ILEC Acronym TXT*** and Verizon. Trunk forecasts provided pursuant to this Agreement must be prepared in good faith but are not otherwise binding on ***ILEC Acronym TXT*** or Verizon.

2.4 Two-Way Interconnection Trunks.

2.4.1 Where the Parties use Two-Way Interconnection Trunks for the exchange of traffic between Verizon and ***ILEC Acronym TXT***, ***ILEC Acronym TXT***, at its own expense, shall:

2.4.1.1 provide its own facilities to the EAB Location(s); and/or

2.4.1.2 obtain transport to the EAB Locations(s) from a third party.

2.4.2 Where the Parties use Two-Way Interconnection Trunks for the exchange of traffic between Verizon and ***ILEC Acronym TXT***, Verizon, at its own expense, shall:

2.4.2.2 provide its own facilities to the EAB Location(s); and/or

2.4.2.3 obtain transport to the EAB Location(s) from a third party.

2.4.3 [Intentionally Left Blank]

2.4.4 Since the Parties have a longstanding traffic history, on an as needed basis but no less frequently than semi-annually, the Parties shall meet and provide to each other a good faith trunk forecast of the number of End Office and Tandem Two-Way Interconnection Trunks that will be needed during the ensuing two (2) year period for the exchange of traffic between ***ILEC Acronym TXT*** and Verizon. Trunk forecasts provided pursuant to this Agreement must be prepared in good faith but are not otherwise binding on ***ILEC Acronym TXT*** or Verizon.

2.4.5 The Parties shall meet (telephonically or in person) from time to time, as needed, to review data on End Office and Tandem Two-Way Interconnection Trunks to determine the need for new trunk groups and to plan any necessary changes in the number of Two-Way Interconnection Trunks.

2.4.6 Two-Way Interconnection Trunks shall have SS7 Common Channel Signaling, where available. The Parties agree to utilize B8ZS and Extended Super Frame (ESF) DS1 facilities, where available.

2.4.7 [Intentionally Left Blank]

2.4.8 Two-Way Interconnection Trunk groups that connect to a Verizon Tandem shall be engineered using a design blocking objective of Neal-Wilkinson B.005 during the average time consistent busy hour. Verizon and ***ILEC Acronym TXT*** shall engineer Two-Way Interconnection Trunks using Telcordia Notes

on the Networks SR-2275 (formerly known as BOC Notes on the LEC Networks SR-TSV-002275).

- 2.4.9 The performance standard for final Two-Way Interconnection Trunk groups shall be that no such Interconnection Trunk group will exceed the B.005 design blocking objective for three (3) consecutive calendar traffic study months.
- 2.4.10 The Parties shall determine and establish, via mutually agreed order documents, the number of Two-Way Interconnection Trunks that are required to meet the applicable design blocking objective for all traffic carried on each Two-Way Interconnection Trunk group.
- 2.4.11 Both Parties shall monitor the Two-Way Interconnection Trunk groups using service results for the applicable design blocking objective. If either Party observes blocking in excess of the applicable design blocking objective, the Parties will promptly take action to expedite resolution of the blocking situation.
- 2.4.12 The Parties will review all Tandem Two-Way Interconnection Trunk groups that reach a utilization level of seventy percent (70%), or greater, to determine whether those groups should be augmented. The Parties will promptly augment all Tandem Two-Way Interconnection Trunk groups that reach a utilization level of eighty percent (80%) by establishing additional trunks sufficient to attain a utilization level of approximately seventy percent (70%), unless the Parties agree that additional trunking is not required. For each Tandem Two-Way Interconnection Trunk group with a utilization level of less than sixty percent (60%), unless the Parties agree otherwise, the Parties will promptly disconnect a sufficient number of Interconnection Trunks to attain a utilization level of approximately sixty percent (60%) for each respective group.
- 2.4.13 [Intentionally Left Blank]

3. [This Section Intentionally Left Blank]

4. Traffic Measurement and Billing over Interconnection Trunks

- 4.1 For billing purposes, each Party shall pass Calling Party Number (CPN) information on at least ninety-eight percent (98 %) of calls carried over the Interconnection Trunks in both the call set up records and the billing records.
- 4.2 At such time as the receiving Party has the capability, on an automated basis, to use such CPN to classify traffic delivered over Interconnection Trunks by the originating Party as Tandem Transit Traffic, such receiving Party shall bill the originating Party the Tandem Transit Traffic Rate applicable to each relevant minute of Tandem Transit Traffic for which CPN is passed. If the receiving Party lacks the capability, on an automated basis, to use CPN information to classify traffic delivered by the other Party as Tandem Transit Traffic, the originating Party will supply appropriate traffic factors. The traffic factors shall be supplied in writing by the originating Party within thirty (30) days of the Effective Date and shall be updated in writing by the originating Party quarterly. Measurement of billing minutes shall be in conversation seconds (the time in seconds that the Parties' equipment is used for a completed call, measured from the receipt of answer supervision to the receipt of disconnect supervision).
- 4.3 Each Party reserves the right to audit all Traffic, up to a maximum of two audits per Calendar Year, to ensure that Tandem Transit Traffic Rates are being applied appropriately; provided, however, that either Party shall have the right to conduct additional audit(s) if the preceding audit disclosed material errors or discrepancies. Each

Party agrees to provide the necessary Traffic data in conjunction with any such audit in a timely manner.

- 4.4 Nothing in this Agreement shall be construed to limit either Party's ability to designate the areas within which that Party's Customers may make calls which that Party rates as "local" in its Customer Tariffs.
- 4.5 [Intentionally Left Blank.]
- 4.6 The Parties may mutually agree in writing to use other methods to measure and classify traffic for billing purposes.
- 4.7 To assure that CPN and other appropriate call detail is passed in both the call set up records and the billing records, the Parties shall utilize, and use their best efforts to have all Other Carriers utilize, the common channel out-of-band signaling (CCS) protocol developed by the Consultative Committee for International Telephone and Telegraph (CCITT) and the American National Standards Institute (ANSI). The Parties agree to exchange traffic using SS7 signaling parameters including, but not limited to ISDN User Part (ISUP), Signaling Points including STPs, SSPs, and SCPs, and any other SS7 parameters necessary for the exchange of traffic. The Parties agree to cooperate on the exchange of all appropriate SS7 messages for call set-up, including Integrated Services Digital Network User Part (ISUP) and Transaction Capability User Part (TCAP) messages, to facilitate full interoperability of all CLASS features and functions between their respective networks. The parties shall also use their best efforts to include the Jurisdiction Information Parameter (JIP) in the Initial Address Message (IAM) containing a Local Exchange Routing Guide-assigned NPA-NXX (6 digits) identifying the originating switch on calls that they originate. The Parties understand that JIP may be used to identify the carrier of traffic, but does not in and of itself establish the jurisdiction of such traffic for billing. All CCS signaling parameters, including, but not limited to the originating End User telephone number, will be provided by each Party in conjunction with all traffic it exchanges. Specifically, each Party shall pass Calling Party Number information on each call that it sends for termination to the other Party. Verizon shall also provide a detailed report that shows the actual volume of MOUs that Verizon is billing each company for and the carriers the MOUs are terminating to so that each ***ILEC Acronym TXT*** can seek direct trunks with the carriers, as referenced in Section 10.7 hereof. The aforementioned call detail records shall be provided to ***ILEC Acronym TXT*** to the extent it is a downstream carrier. Where Verizon is not the originating carrier, it shall provide all call detail as received from the originating carrier and shall use its best efforts to obtain complete call detail from all originating carriers.

Furthermore, neither Party shall intentionally remove, substitute or generate incorrect ANI, CPN, Carrier Identification Parameter (CIP) or SS7 parameters on traffic exchanged pursuant to this Agreement. Upon determination that a Party has intentionally removed, substituted or generated any such parameters on traffic exchanged or delivered pursuant to this Agreement, the offending Party shall pay the other Party the difference between compensation paid (if any) and applicable access charges, plus interest due under the terms of the applicable access tariff from the date the traffic would have been billed if such parameters had been passed unaltered. In addition, the Parties acknowledge that a violation of this paragraph would constitute a default of this Agreement.

The Parties shall provide all Call Detail Records, including the aforementioned detail, to each other at no cost.

5. [This Section Intentionally Left Blank]
6. [This Section Intentionally Left Blank]

7. [This Section Intentionally Left Blank]

8. [This Section Intentionally Left Blank]

9. [This Section Intentionally Left Blank]

10. Local Tandem Transit Traffic

10.1 As used in this Section, Local Tandem Transit Traffic is as defined in the Glossary Section 2.40

10.2 Local Tandem Transit Traffic Service provides the originating Party with the transport of Local Tandem Transit Traffic as provided below in this Section 10.

10.3 The originating Party shall pay the transiting Party for Tandem Transit Traffic Service at the applicable rates specified in the Pricing Attachment.

10.4 Local Tandem Transit Traffic shall be routed over the Interconnection Trunks described in Section 2 of this Attachment. The originating Party shall deliver Tandem Transit Traffic to the transiting Party's network (EAB location) with CCS and the appropriate Transactional Capabilities Application Part ("TCAP") message to facilitate full interoperability of CLASS Features and billing functions.

10.5 The originating Party may use Tandem Transit Traffic Service only for traffic that originates on the originating Party's network. The originating Party shall not use the transiting Party's Tandem Transit Service to send traffic that does not originate on the originating Party's network.

10.6 Neither Party will be liable to the other as a result of this Agreement for the payment of compensation to any Other Carriers for Local Tandem Transit Traffic. Each Party if billed by any Other Carrier for any originating traffic, the other Party may provide notice to the other Party of such billing. Upon receipt of such notice, and where the other Party believes it appropriate, the other Party shall contact such Other Carrier to request that the Other Carrier remove such charges from its bills.

10.7 If the Transiting Party's Tandem Transit Traffic Service reaches traffic volumes that exceed the Centum Call Seconds (Hundred Call Seconds) busy hour equivalent of 200,000 combined minutes of use per month (a DS1 equivalent) to the subtending End Office of a particular Other Carrier for any month (the "Threshold Level"), the Parties shall use good faith efforts for the Other Carrier to establish direct interconnection with the non-transiting Party and reduce such traffic volumes below the Threshold Level. If either Party believes that the other Party has not exercised good faith efforts promptly to obtain such direct interconnection, either Party may use the Dispute Resolution processes of this Agreement.

10.8 Neither Party shall take any actions to prevent the other Party from entering into a direct and reciprocal traffic exchange arrangement with any carrier to which it originates, or from which it terminates, traffic, nor to entering in to transit arrangements with any other entity..

11. [This Section Intentionally Left Blank]

12. Joint Network Implementation and Grooming Process; Forecasting

12.1 The Parties understand that the arrangements and provision of service as contemplated by this Agreement may require technical and operational coordination between the Parties. Accordingly, the Parties agree to work cooperatively to implement this Agreement and the Parties agree to provide each other with such information as may be necessary to establish and maintain services under this Agreement.

13. [This Section Intentionally Left Blank]
14. [This Section Intentionally Left Blank]

PRICING ATTACHMENT

1. General

- 1.1 As used in this Attachment, the term "Charges" means the rates, fees, charges and prices for a Service.

2. Verizon Charges

- 2.1 Charges for Services provided by Verizon under this Agreement shall be as stated in this Section 2.
- 2.2 The Charges for a Service shall be the Charges for the Service stated in Appendix A of this Attachment.
- 2.3 In the absence of Charges for a Service established pursuant to Section 2.2 of this Attachment, if Charges for a Service are otherwise expressly provided for in this Agreement, such Charges shall apply.
- 2.4 In the absence of Charges for a Service established pursuant to Sections 2.2 through 2.3 of this Attachment, the Charges for the Service shall be as stated in Verizon's applicable Tariff.
- 2.5 In the absence of Charges for a Service established pursuant to Sections 2.2 through 2.4 of this Attachment, the Charges for the Service shall be Verizon's FCC or Commission approved Charges applicable to ***ILEC Acronym TXT***.
- 2.6 In the absence of Charges for a Service established pursuant to Sections 2.2 through 2.5 of this Attachment, the Charges for the Service shall be mutually agreed to by the Parties in writing.

3. ***ILEC Acronym TXT*** Charges

- 3.1 Charges for Services provided by ***ILEC Acronym TXT*** under this Agreement shall be as stated in this Section 3.
- 3.2 The Charges for a Service shall be the Charges for the Service stated in Appendix B of this Attachment.
- 3.3 In the absence of Charges for a Service established pursuant to Section 3.2 of this Attachment, if Charges for a Service are otherwise expressly provided for in this Agreement, such Charges shall apply.
- 3.4 In the absence of Charges for a Service established pursuant to Sections 3.2 through 3.3 of this Attachment, the Charges for the Service shall be as stated in ***ILEC Acronym TXT*** applicable Tariff.
- 3.5 In the absence of Charges for a Service established pursuant to Sections 3.2 through 3.4 of this Attachment, the Charges for the Service shall be ***ILEC Acronym TXT*** FCC or Commission approved Charges applicable to Verizon or other ILECs
- 3.6 In the absence of Charges for a Service established pursuant to Sections 3.2 through 3.5 of this Attachment, the Charges for the Service shall be mutually agreed to by the Parties in writing.

4. Regulatory Review of Prices

Notwithstanding any other provision of this Agreement, each Party reserves its respective rights to institute an appropriate proceeding with the FCC, the Commission or other governmental body of appropriate jurisdiction with regard to the Charges for each Party's services.

SCHEDULE XX

LIST OF ***ILEC Acronym TXT***'S NON-OPTIONAL EXTENDED LOCAL CALLING SCOPE
ARRANGEMENTS

Originating Exchange

Terminating Exchange

In instances where ***ILEC Acronym TXT***' provides transit service there would be inserted a comparable Schedule YY for Verizon

RECEIVED

2011 AUG -1 PM 4:03

SA PUC
SECRETARY'S BUREAU

EXHIBIT GMZ-4



ABOUT US

PRODUCTS AND SERVICES

INVESTOR RELATIONS

REGULATORY

CUS

ABOUT US

COMPANY OVERVIEW <<

Facts
Network Video

TANDEM NETWORKS

MARKETS

MANAGEMENT TEAM

PRESS RELEASES

UPCOMING TRADE SHOWS

CAREERS

CONTACT US

Company Overview



Neutral Tandem was founded on the principle that a tandem network must be neutral—meaning, not owned by any one incumbent carrier—and is critical to the type of vigorous competition that ultimately results in lower-cost, higher-value telecommunications services for consumers and enterprises. Neutral Tandem established such a network, making it more efficient and cost-effective for wireless carriers, cable companies, CLECs and broadband service providers to streamline interconnections between one another. To learn how Neutral Tandem began and the power of the **network effect**, [click here](#).

Neutral Tandem provides tandem services for wholesale long distance, local transit, international long distance, HD Voice, and much more. As a leading provider of tandem services for carriers and service providers, Neutral Tandem's network infrastructure:

- Improves the reliability of the Public Switched Telephone Network (PSTN), by providing diversity in tandem switching.
- Reduces competitive tensions between carriers.
- Provides a cost effective alternative to the incumbent tandem network.
- Offers the ability to both originate and terminate local and long distance traffic using SIP or TDM.

Today, Neutral Tandem is used by nearly every national and regional wireless carrier, cable and CLEC in the markets it serves; and its network carries over ten billion minutes of traffic per month. To learn more about the product line and why customers select Neutral Tandem, [visit the Products and Services section](#).



Copyright ©2010 Neutral Tandem, Inc. | All Rights Reserved. | 550 W. Adams, 9th Floor | Chicago



ABOUT US

PRODUCTS
AND SERVICES

INVESTOR
RELATIONS

REGULATORY

CUSTOMER
SUPPORT

PRODUCTS AND
SERVICES

OVERVIEW

LOCAL TRANSIT SERVICE
NATIONAL TRANSIT SERVICE
TERMINATING SWITCHED
ACCESS
ORIGINATING SWITCHED
ACCESS
ETHERCLOUDSM
COMMONPOINT[®]
HOSTED SERVICES

Products & Services

Since its inception in 2003, Neutral Tandem has continuously developed and built upon its reputation as a leader in the telecommunications industry dedicated to developing and delivering innovative solutions to help competitive carriers interconnect their networks.

Neutral Tandem earned this reputation by creating the first independent network devoted exclusively to transforming how wireless, cable, CLEC and broadband telephony companies route local transit traffic to one another. Neutral Tandem then extended its reach and product line by interconnecting its markets with a nationwide, next-generation network built to support a range of access services. Each new service launched is designed to both leverage and strengthen Neutral Tandem's extensive network of direct end office connections. This provides competitive carriers with an unparalleled call termination field of direct routes yielding premier levels of network quality and reliability. This extensive network serves as the foundation for the *network effect*, which describes how the power of the network increases geometrically with each additional termination point added. [Click here to see a video](#) explaining the power of the *network effect* and how Neutral Tandem began.

Neutral Tandem stands out as the leader of managed tandem services facilitating interconnections between carriers; this is why nearly every major competitive carrier in the U.S. uses Neutral Tandem to route over 10 billion of minutes of traffic each month. Neutral Tandem's products and services offer:

- An all-IP scalable and resilient network
- A *neutral* platform dedicated exclusively to supporting carriers vs. competing with them
- A network that exchanges traffic for over 110 major wireless, CLEC and cable service providers
- Multi-protocol interface capabilities to ease interconnection with next-generation switching equipment

To learn more, [contact us](#).



Copyright ©2010 Neutral Tandem, Inc. | All Rights Reserved. | 550 W. Adams, 9th Floor | Chicago, IL

CERTIFICATE OF SERVICE

I hereby certify that on this 1st day of August, 2011, I did serve a true and correct copy of the foregoing upon the persons below via electronic mail and first class mail as follows:

Susan D. Paiva Esquire
Verizon
1717 Arch Street
Philadelphia, PA 19103
Suzan.D.Paiva@Verizon.com

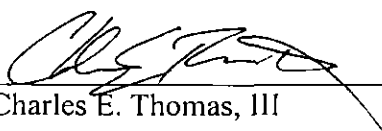

Charles E. Thomas, III

RECEIVED
2011 AUG -1 PM 4:03
PA 306
SECRETARY'S BUREAU