



CenturyLink™

October 16, 2012

RECEIVED

OCT 16 2012

PA PUBLIC UTILITY COMMISSION
SECRETARY'S BUREAU

Ms. Rosemary Chiavetta
Secretary
Pennsylvania Public Utility Commission
P.O.Box 3265
400 North Street
Harrisburg, Pa. 17105-3265

RE: Proposed Placement of Facilities Within York Railway R/W
York County, Pennsylvania; AARDOT # 535233B

Dear Ms. Chiavetta:

Enclosed for your review is an application or placement of facilities crossing the railroad right-of-way owned by York Railway in York County, Pennsylvania. Along with the application, are the plan/profile drawings for the proposed facility placement along with a Certificate of Service.

Please review this application and provide authorization to proceed with this work.

If you need additional information, I can be reached at 937-843-5266 or via e-mail at linda.m.pinkerton@centurylink.com.

Thank you.

Sincerely,

Linda Pinkerton
Real Estate Field Agent

12902 St. Rt. 274 W.
Lewistown, Oh. 43333
Tel: 937-843-5266
Fax: 913-397-3984
www.centurylink.com

**BEFORE
PENNSYLVANIA PUBLIC UTILITY COMMISSION**

In re: Application of **The United Telephone Company of Pennsylvania, LLC d/b/a CenturyLink** for approval of the alteration of the crossing DOT # 535233B by the installation of an additional aerial fiber cable where Jacobs Mill Rd (SR3045) crosses at grade, the tracks of York Railway, located in York County.

Application
Docket No.

RECEIVED

OCT 16 2012

PA PUBLIC UTILITY COMMISSION
SECRETARY'S BUREAU

To Pennsylvania Public Utility Commission:

1. The name and address of applicant are **The United Telephone Company of Pennsylvania, LLC d/b/a CenturyLink**

.....
2. The name and address of applicant's attorney are .
Sue Benedek, 240 N. 3rd St., Suite 300, Harrisburg, Pa. 17101

3. **The United Telephone Company of Pennsylvania, LLC d/b/a CenturyLink proposes the placement one (1) aerial 96 fiber optic cable to be lashed to an existing 8 fiber cable.**

4. The United Telephone Company of Pennsylvania, LLC d/b/a CenturyLink proposes **placing one (1) aerial 96 fiber optic cable to be lashed to an existing 8 fiber optic cable over the York Railway** as indicated in the enclosed plan/profile drawings

5. **Notice (Certificate of Service) has been submitted to PENN DOT and York Railway c/o RelTek, LLC.**

6. The estimated cost of installing the facilities is \$1,500. Parties responsible for installing, maintaining and inspecting the facilities are The United Telephone Company of Pennsylvania, LLC d/b/a CenturyLink or its agents.

7. The alteration is necessary or proper for the following reasons: The facility is required to provide cabling to a Shentel cell tower in the Hanover, Pennsylvania exchange.

Wherefore, applicant prays your Honorable Commission to approve the application:

The United Telephone Company of Pa., LLC
d/b/a CenturyLink

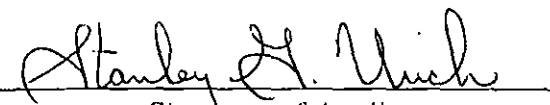
Signature of Applicant

RECEIVED

OCT 16 2012

PA PUBLIC UTILITY COMMISSION
SECRETARY'S BUREAU

RELTEK

APPLICATION FOR WIRELINE OCCUPANCIES

ReLTEK use only	rev: 1-1-12
File #:	_____
Date Received:	_____

APPLICATION FEE: A non-refundable fee of \$800.00 is due with submission of this application.

This application fee does not include any fees for: (a) special handling, (b) engineering review, (c) document preparation, (d) rents, (e) Railroad Protective Insurance, (f) preparation of estimates, (g) flagmen/watchmen costs/expenses or (h) construction costs incurred by the railroad. Payment of all additional fees is due prior to construction. Construction cost estimates for railroad's portion of the project (if any) may be requested, and will be prepared at the sole cost and expense of Applicant.

All applications are to be submitted in accordance with appropriate ReLTEK Specifications for Right of Way Occupancies. Failure to conform to these specifications may result in delays, additional costs, return or denial of your application. Construction drawings should be no larger than 11" x 17" in size. Larger size drawings are accepted in special circumstances, with prior approval of ReLTEK.

No work on railroad's property may proceed until Applicant is in receipt of a fully executed Occupation Agreement and has received authorization from railroad's engineering representative. No verbal approvals are granted or implied.

Name of Applicant: The United Telephone Company of Pennsylvania LLC d/b/a CenturyLink
(Exact name to be shown on Occupancy Agreement)

Applicant is: Individual Corporation* LLC* Municipality Other: _____
* State of Incorporation or registration PA (corporation or LLC)

Applicant's Mailing Address:
100 CenturyLink DR.
MONROE, LA. 71203

Send Document to: (If different than Applicant's address)
12902 ST RT 274W.
LEWISTOWN, OH. 43333

Attention: _____
Title: _____
Telephone #: (_____) _____
email address: _____

Attention: Linda Pinkerton
Title: Real Estate Negotiator
Telephone #: (937) 843-5266
email address: linda.m.pinkerton@centurylink.com

Location of Occupancy:

Name of railroad over which occupancy is applied: YORK RAILWAY
 City Town Village: _____ Township: _____
County: YORK State: PA Footage (_____) and direction (N / S / E / W)
from Mile Post #: _____ or center line of Public Highway Crossing or Bridge: JACOBS MILL Rd (SR3045)
(Name / Number)

Occupation to be located within confines of Dedicated Highway (right of way lines must be shown on plan)

Highway Name or Number: _____ AAR DOT #: 535233B
(AAR DOT# is posted near crossing)

Type of Facilities:

- Wire / Cable: Aerial Undergrade (in conduit)
- Telephone (# of pairs: _____) Electrical (voltage: _____) Fiber Optic CATV
- Phase of electrical circuits: _____ Number of electrical circuits: _____ Number of Poles: _____
- Crossing Angle: _____° Longitudinal (Total footage of occupancy: _____)
- Revision to existing facilities (*Copy of original agreement must be included with application*)

Method of conduit installation (if undergrade):

- Open Cut Bore & Jacking Jacking Tunneling Other _____

SEND COMPLETED APPLICATION TO:

ReLTEK, LLC
 651 High Street Suite 203
 Burlington, NJ 08016

Attention: Occupancy Agreements

Email: occupancies@reltekservices.com

RECEIVED

OCT 16 2012

APPLICANT'S CHECK LIST

PA PUBLIC UTILITY COMMISSION
 SECRETARY'S BUREAU

- 1) Review Specifications.
- 2) Proper name and mailing address of Licensee.
- 3) Application fee.
- 4) Location data
- 5) Plan and Profile drawings (no larger than 11" x 17").
- 6) Depth of bury (if undergrade)
- 7) Method of installation (if undergrade)
- 8) Size, voltage, type and number of: wires, cables or Fiber Optic Cables
- 9) Wire/Cable vertical clearance from sag to top of rail or highest grade of ROW if no tracks are present
- 10) Distance from poles to centerline of track, path or trail or centerline of ROW if no improvements are present
- 11) Pole configuration.
- 12) Angle of crossing.
- 13) Number of tracks (if crossing is over railroad).
- 14) Length of any longitudinal occupancy.
- 15) R/W lines of Dedicated Highway (for crossings within public highways).
- 16) Bridge Footing of Dedicated Highway Bridge.
- 17) Bridge Attachment for Dedicated Highway Bridge.

****Warning**:**

Extreme caution is to be used in excavation due to the possible existence of other underground facilities along railroad's right of way. Any damage to existing facilities will be the sole responsibility of the Applicant. In compliance with State law, prior to commencing work, the contractor shall notify appropriate State "One Call" service. Please note that submission of an application or payment of an application fee does not imply or guarantee acceptance of proposal and granting of an agreement. By signature below, applicant acknowledges and accepts the terms and conditions stated herein.

Submitted by:

Linda Pinkerton
 Name

Real Estate Negotiator
 Title

10/16/12
 Date

RECEIVED

OCT 16 2012

PA PUBLIC UTILITY COMMISSION
SECRETARY'S BUREAU

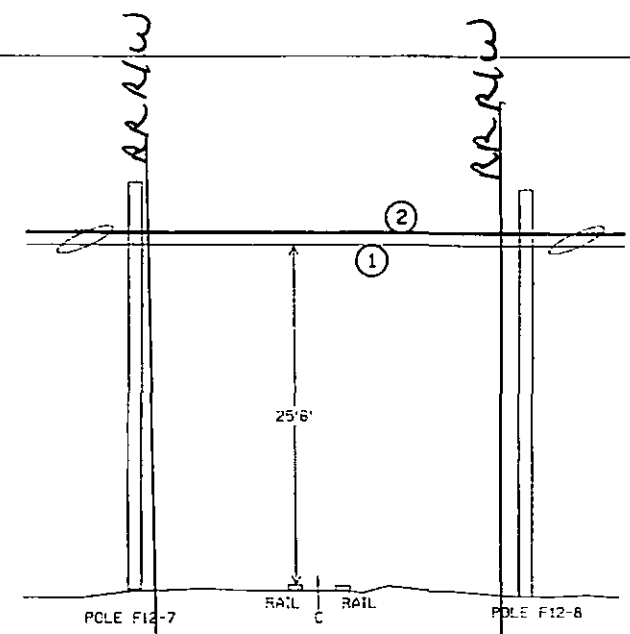
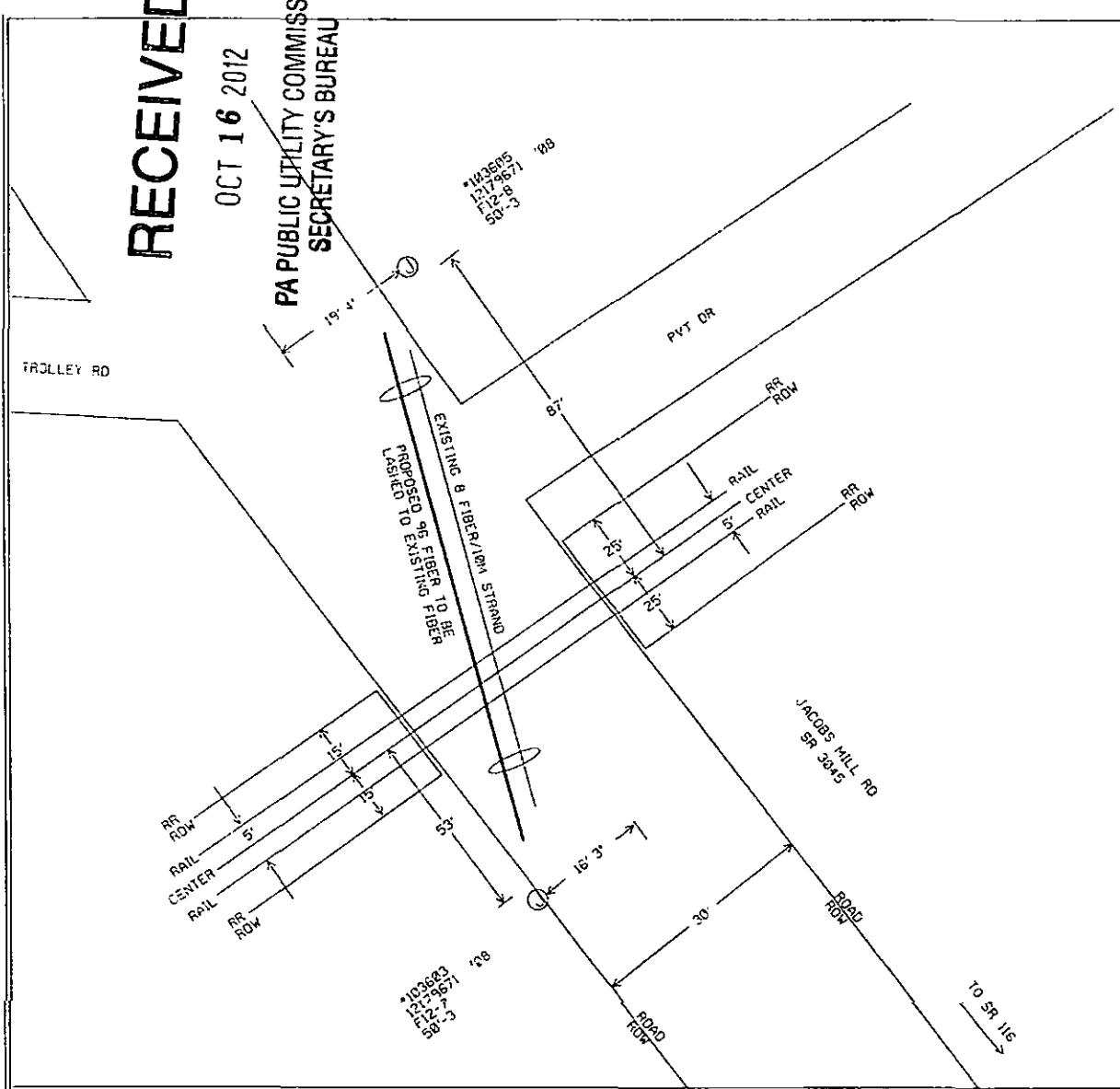

- ① EXISTING 8 FIBER ON 10M STRAND
WT. - .079 LB/FT
DIA. - .47 INCHES
- ② PROPOSED 96 FIBER TO BE LASHED
TO EXISTING 8 FIBER
WT. - .134 LB/FT
DIA. - .62 INCHES

YORK RAILWAY
CROSSING 535233B
LAT 39.8323794 LON -76.9279539

JACOBS MILL ROAD (SR 3045)
YORK COUNTY, PA



Title: RRPERRIT	Township/Taxcode: 12891 HEDELBERG	Exchange: HNV RPA	Map:	Engineer: LCH	Work Order: RRPERRIT
Location: JACOBS MILL RD	Manager:	CO:	Scale: 1"=50'	Phone:	Sheet: 2 of 2
				WD Create: 09/26/2012	Print Date: 10/02/2012

§ 1.36. Verification.

(a) Applications, petitions, formal complaints, motions and answers thereto containing an averment of fact not appearing of record in the action or containing a denial of fact shall be personally verified by a party thereto or by an authorized officer of the party if a corporation or association. Verification means a signed written statement of fact supported by oath or affirmation or made subject to the penalties of 18 Pa. C.S. §4904 (relating to unsworn falsification to authorities). If verification is required, notarization is not necessary.

(b) The Verification form should comply substantially with the following:

VERIFICATION

I, Stanley G. Urich, hereby state that the facts above set forth are true and correct to the best of my knowledge, information and belief, and that I expect to be able to prove the same at a hearing held in this matter. I understand that the statements herein are made subject to the penalties of 18 Pa. C.S. § 4904 (relating to unsworn falsification to authorities).

Date: 10/16/12

Stanley G. Urich
(Signature)

RECEIVED

OCT 16 2012

PA PUBLIC UTILITY COMMISSION
SECRETARY'S BUREAU

CERTIFICATE OF SERVICE

I hereby certify that I have this day served a true copy of the foregoing document upon the participants, listed below, in accordance with the requirements of § 1.54 (relating to service by participant).

*PA Dept of Transportation
District 8-4.
Highway Occupancy
2140 Herr Street
Harrisburg, Pa. 17103-1699*

*York Railway
.c/o RelTek, LLC
651 High St., Suite 203
Burlington, NJ 08016
Attn: Steve Sampson
Ph: 609-387-4357*

*Mark Chappell, PE Chief
RPW & Utility Division
PENN DOT Bureau of Design
P.O.Box 3362
Harrisburg, Pa. 17105-3362*

*Gina M. D'Alfonso
Dept. of Transportation
Office of Chief Counsel
9th Floor
P.O.Box 8212
Harrisburg, Pa. 17105-8212*

RECEIVED

OCT 16 2012

**PA PUBLIC UTILITY COMMISSION
SECRETARY'S BUREAU**

Dated this 16th of October, 2012

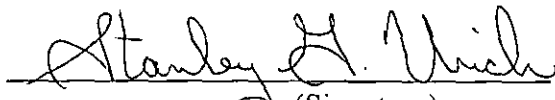
(Signature)

LINDA PINKERTON
NEWPORT 2V1A04
12902 ST. RT. 274 W.
LEWISTOWN OH 43333

1 LBS

1 OF 1

SHIP TO:

ROSEMARY CHIAVETTA
PUBLIC UTILITY COMMIMSSION
BUREAU OF TECHNICAL UTILITY SVCS.
COMMONWEALTH OF PENNSYLVANIA
400 NORTH STREET
HARRISBURG PA 17120-0200

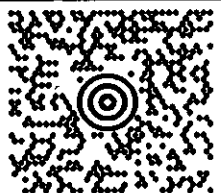

PA 171 9-20



UPS NEXT DAY AIR SAVER 1P

TRACKING #: 1Z 2V1 A04 13 9489 0778

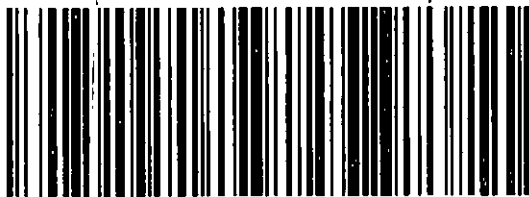

BILLING: P/P

Cost C
Refere

TO: CHIAVETTA, R. PUC (CHIAVE)
Agency: PUC
Floor:
External Carrier: UPS



10/17/2012 10:24:53