



15 Montgomery Place  
Pittsburgh, PA 15212

June 20, 2013

Ms. Rosemary Chiavetta, Secretary  
PA Public Utility Commission  
P. O. Box 3265  
Harrisburg, PA 17105-3265

RE: Butler Street, Springdale Borough Crossing 510 879V

Dear Ms. Chiavetta:

Enclosed is the application to the PUC for Verizon Pennsylvania LLC approval to construct an aerial fiber optic cable in the Borough of Springdale, Allegheny County, PA. To complete this work, we must cross Norfolk Southern Railroad in the public right of way at Butler Street, Springdale, Allegheny County, PA, Crossing #510879V.

All parties have been notified.

Sincerely

A handwritten signature in cursive script that reads "Deborah Delia".

Deborah Delia

Verizon Pennsylvania LLC  
412-237-2285

**BEFORE  
PENNSYLVANIA PUBLIC UTILITY COMMISSION**

In re: Application of Verizon Pennsylvania LLC for approval for construction of an aerial fiber optic cable in the Borough of Springdale, Allegheny County, PA. To complete this work, we must cross Norfolk Southern Railroad in the public right of way at Butler Street, Springdale, Allegheny County, PA, Crossing #510 879V.

To Pennsylvania Public Utility Commission:

1. The name and address of applicant are

Verizon Pennsylvania LLC  
Attn: Deborah Delia  
15 E. Montgomery Place, 2<sup>nd</sup> Floor  
Pittsburgh, PA 15212

2. The name and address of applicant's attorney are:

Suzan D. Paiva  
Assistant General Counsel  
1717 Arch Street  
3rd Floor  
Philadelphia, Pennsylvania 19103

3. Verizon Pennsylvania LLC requests permission to construct a 1.25" aerial duct containing a 48 strand fiber optic cable in the Borough of Springdale, Allegheny County, PA. To complete this work, we must cross Norfolk Southern Railroad in the public right of way at Butler Street, Springdale, Allegheny County, PA, Crossing #5108 79V. **Projected Start Date of this project is August 5, 2013.**
4. The proposed construction of fiber optic cable being attached to 70-6 and 70-5 existing Verizon Pennsylvania LLC poles. Proposed completion date of this project is December 31, 2013.
5. The public utilities, municipalities, corporations, and property owners concerned in, or affected by, the crossing alterations are in Exhibit "B".

6. The motoring public or rail traffic will not be impacted. Verizon Pennsylvania LLC will use normal construction procedures including flagmen to maintain normal flow of traffic. The estimated cost of this project is \$15,000.00.
7. The alterations at this crossing are necessary for Verizon Pennsylvania LLC to provide requested service to RI Lampus.
8. Wherefore, applicant prays your Honorable Commission to approve the application:

1.36 Verification

- (a) Applications, petitions, formal complaints, motions and answers thereto containing an averment of fact not appearing of record in the action or containing a denial of fact shall be personally verified by a party thereto or by an authorized officer of the party if a corporation or association. Verification means a signed written statement of fact supported by oath or affirmation or made subject to the penalties of 18 Pa. C.S. 4904 (relating to unsworn falsification to authorities). If verification is required, notarization is not necessary.
- (b) The Verification form should comply substantially with the following:

### VERIFICATION

I Deborah Delia hereby state that the facts above set forth are true and correct (or are true and correct to the best of my knowledge, information and belief) and that I expect to be able to prove the same at a hearing held in this matter. I understand that the statements herein are made subject to the penalties of 18 Pa. C.S. 4904 (relating to unsworn falsification to authorities).

Date: 6-20-13

Deborah Delia  
Signature

# Exhibit A

## PROFILE VIEW

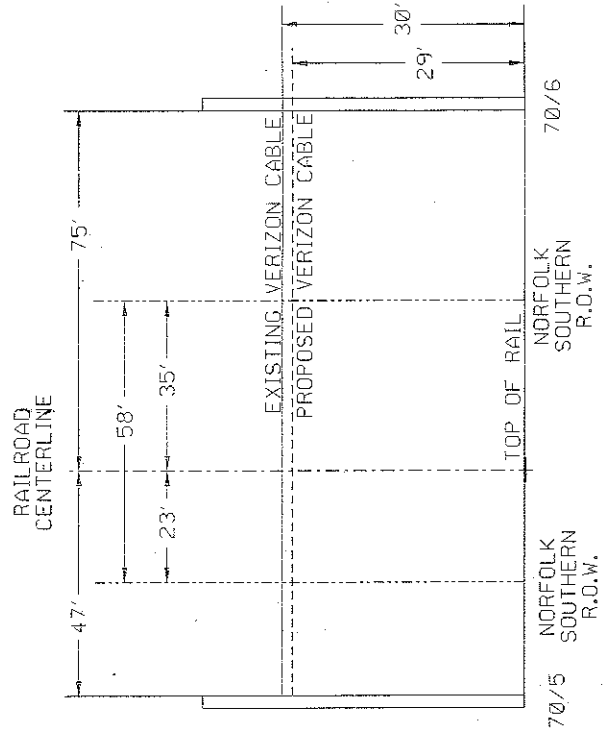

## PLAN VIEW

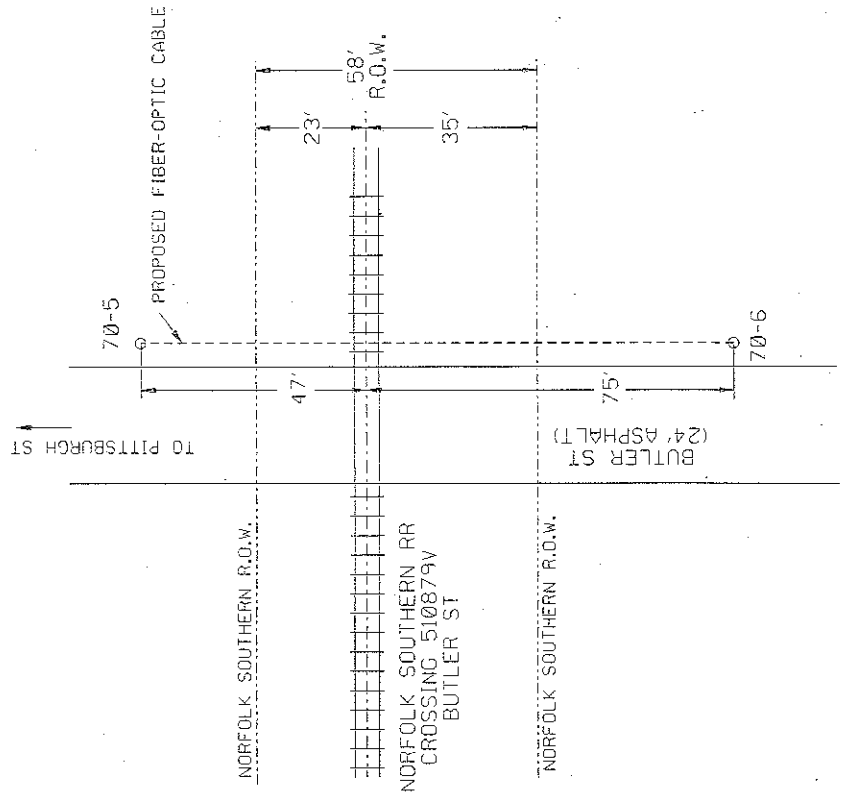

## EXHIBIT B

The public utilities, municipalities, corporations, and property owners concerned in, or affected by, the crossing alterations are:

PennDOT Bureau of Design  
Mark D. Chappell, PE CHIEF  
Keystone Building – 7<sup>th</sup> Floor  
P. O. Box 3362  
Harrisburg, PA 17105-3362

Ms. Gina M. D'Alfonso  
Assistant Counsel in Charge  
Dept. of Transportation  
Office of Chief Personnel  
P. O. Box 8212  
9<sup>th</sup> Floor  
Harrisburg, PA 171005-8212

The Honorable Richard Fitzgerald, County Executive  
Allegheny County Commissioners  
436 Grant Street  
Room 101  
Pittsburgh, PA 15219

The Honorable Eileen Miller, Mayor  
Springdale Borough  
325 School Street  
Springdale, PA 15144

Rodney D. Bender, PE Manger  
Public Utility Commission  
Rail Safety Division  
P. O. Box 3265  
Harrisburg, PA 17105

Mr. Ronald Borczyk  
Borough Manager  
Springdale Borough  
325 School Street  
Springdale, PA 15144

Mr. Dan Cessna, P.E.  
PA Department of Transportation  
DIST11  
45 Thoms Run Road  
Bridgeville, PA 15017

AECOM  
1700 Market Street  
16<sup>th</sup> Floor  
Philadelphia, PA 19103

Mr. W. L. Barringer  
Director Grade Crossing Safety  
Norfolk Southern Corporation  
1200 Peachtree St., NE, Box 36  
Atlanta, GA 30309-0036

Mr. Craig Webb  
P.E. Division Eng., Pgh  
Norfolk Southern Corporation  
425 Holiday Drive  
Foster 2 Plaza  
Pittsburgh, PA 15220

Ms. Lisa Marinelli  
West Penn Power  
800 Cabin Hill Drive  
Greensburg, PA 15601

---

## CERTIFICATE OF SERVICE

I hereby certify that I have this day served a true copy of the foregoing document upon the participants, listed below, in accordance with the requirements of 1.54

PennDOT Bureau of Design  
Mark D. Chappell, PE CHIEF  
Keystone Building – 7<sup>th</sup> Floor  
P. O. Box 3362  
Harrisburg, PA 17105-3362

Ms. Gina M. D'Alfonso  
Assistant Counsel in Charge  
Dept. of Transportation  
Office of Chief Personnel  
P. O. Box 8212  
9<sup>th</sup> Floor  
Harrisburg, PA 171005-8212

The Honorable Richard Fitzgerald, County Executive  
Allegheny County Commissioners  
436 Grant Street  
Room 101  
Pittsburgh, PA 15219

The Honorable Eileen Miller, Mayor  
Springdale Borough  
325 School Street  
Springdale, PA 15144

Rodney D. Bender, PE Manger  
Public Utility Commission  
Rail Safety Division  
P. O. Box 3265  
Harrisburg, PA 17105

Mr. Ronald Borczyk  
Borough Manager  
Springdale Borough  
325 School Street  
Springdale, PA 15144

Mr. Dan Cessna, P.E.  
PA Department of Transportation  
DIST11  
45 Thoms Run Road  
Bridgeville, PA 15017

AECOM  
1700 Market Street  
16<sup>th</sup> Floor  
Philadelphia, PA 19103

Mr. W. L. Barringer  
Director Grade Crossing Safety  
Norfolk Southern Corporation  
1200 Peachtree St., NE, Box 36  
Atlanta, GA 30309-0036

Mr. Craig Webb  
P.E. Division Eng., Pgh  
Norfolk Southern Corporation  
425 Holiday Drive  
Foster 2 Plaza  
Pittsburgh, PA 15220

Ms. Lisa Marinelli  
West Penn Power  
800 Cabin Hill Drive  
Greensburg, PA 15601

Dated this day 20<sup>th</sup> JUNE, 2013

  
Signature