

Linda M. Vashlishan
Supervisor – Right of Way
Tel.: (570) 348-4664
Cell: (610) 849-3105

PPL Electric Utilities
600 Larch Street
Scranton, PA 18509
lmvashlishan@pplweb.com



January 16, 2014

A-2013-2398812

Ms. Rosemary Chiavetta, Secretary
Pennsylvania Public Utility Commission
PO Box 3265
Harrisburg, PA 17105-3265

**RE: Application for Public Crossing
State Route 590
Stourbridge Railroad Company
Township of Lackawaxen
County of Pike**

~~PA PUBLIC UTILITY COMMISSION
BUREAU OF
JAN 21 2013
TECHNICAL UTILITY SERVICES
RAIL SECTION~~

Dear Secretary Chiavetta:

On December 19, 2013, I sent to you under separate cover the original documents pertaining to this application. The drawing that was included with that package, however, was incorrect. Please find enclosed the package with the revised plan (PPL DWG EU00503859).

If you have any questions, please do not hesitate to contact me.

Sincerely,

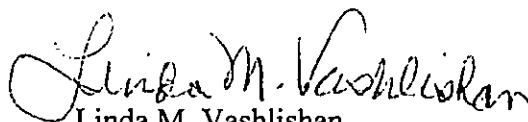
Linda M. Vashlishan
Supervisor – Right of Way

LMV/sbe
Enclosure

cc: Rodney D. Binder, P.E.
Chief Bureau of Rail Safety
Pennsylvania Public Utility Commission
PO Box 3265
Harrisburg, PA 17105-3265

RECEIVED

JAN 28 2014
PA PUBLIC UTILITY COMMISSION
SECRETARY'S BUREAU

Linda M. Vashlishan
Supervisor – Right of Way
Tel.: (570) 348-4664
Cell: (610) 849-3105

PPL Electric Utilities
600 Larch Street
Scranton, PA 18509
lmvashlishan@pplweb.com

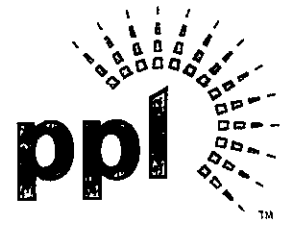

December 19, 2013

Ms. Rosemary Chiavetta, Secretary
Pennsylvania Public Utility Commission
PO Box 3265
Harrisburg, PA 17105-3265

**RE: Application for Public Crossing
State Route 590
Stourbridge Railroad Company
Township of Lackawaxen
County of Pike**

PA PUBLIC UTILITY COMMISSION
BUREAU OF
JAN 21 2013
TECHNICAL UTILITY SERVICES
RAIL SECTION

Dear Secretary Chiavetta:

In accordance with Public Utility Code, Title 66, Chapter 2702, enclosed please find an application and 3 copies requesting permission to alter crossing of **Stourbridge Railroad Company**. Said crossing will be within the public right-of-way confines of **State Route 590**. It is located in the **Township of Lackawaxen, Pike County**.

Said crossing will consist of installation of PPL's overhead facilities as they cross the **Stourbridge** tracks and right of way. The **overhead cables and conductors** will be located within public right of way. This is an existing crossing, 263844M.

PPL Electric Utilities will provide copies of same to all parties listed under its Certificate of Service.

Please review and provide the appropriate authorization to this office. Should you have any questions, please contact this office.

Sincerely,

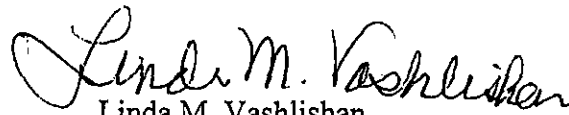
Linda M. Vashlishan
Supervisor – Right of Way

LMV/sbe
Enclosures

cc: Rodney D. Binder, P.E.
Chief Bureau of Rail Safety
Pennsylvania Public Utility Commission
PO Box 3265
Harrisburg, PA 17105-3265

**BEFORE
PENNSYLVANIA PUBLIC UTILITY COMMISSION**

In re: Application of **PPL Electric Utilities Corporation** for approval of the alteration of the crossing **263844M** by the installation of **7.2kv overhead conductors** where **State Route 590** crosses at grade the tracks of the **Stourbridge Railroad Company** in the **Township of Lackawaxen in Pike County**.

Application
Docket No **A-2013-2398812**

To Pennsylvania Public Utility Commission:

1. The name and address of applicant are PPL Electric Utilities Corporation, 2 North Ninth Street, Allentown, PA 18101-1179.
2. The name and address of applicant's attorney are Paul E. Russell, Associate General Counsel, PPL Electric Utilities Corporation, 2 North Ninth Street, Allentown, PA 18101-1179.
3. PPL Electric Utilities Corporation (PPL), a Pennsylvania Public Utility offers electric utility service. PPL maintains a corporate charter in Pennsylvania, wherein the by-laws permit public utility companies to occupy public spaces, including said crossing.
4. PPL proposes to install and cross **State Route 590** with Three (3) 477 Aluminum XLP 7.2kv open wire primary, 1 4/0 ACSR neutral. See attached plan for specifications.
5. Affected parties: (See attached exhibit "A")
6. **State Route 590** is a two-lane bituminous asphalt roadway. Scope of proposed work is relatively minor in scope and construction time frame will be short in duration, a formal traffic study was not conducted. Appropriate traffic control will be employed in accordance with PennDOT highway requirements. Operating Railroad will be contacted to arrange for appropriate flagging/protection services.
7. The construction costs associated with this proposal would be approximately \$9,000.00.
8. The construction of said crossing, of the tracks of the **Stourbridge Railroad Company**, is necessary to install PPL Electric Utilities Corporation's overhead electrical system.

Wherefore, applicant prays your Honorable Commission to approve the application:

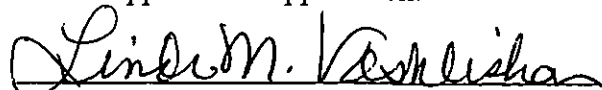
Linda M. Vashlishan
Supervisor – Right of Way
PPL Electric Utilities Corporation

§ 1.36. Verification.

(a) Applications, petitions, formal complaints, motions and answers thereto containing an averment of fact not appearing of record in the action or containing a denial of fact shall be personally verified by a party thereto or by an authorized officer of the party if a corporation or association. Verification means a signed written statement of fact supported by oath or affirmation or made subject to the penalties of 18 Pa. C.S. §4904 (relating to unsworn falsification to authorities). If verification is required, notarization is not necessary.

(b) The Verification form should comply substantially with the following:

VERIFICATION

I, **Linda M. Vashlishan**, hereby state that the facts above set forth are true and correct (or are true and correct to the best of my knowledge, information and belief) and that I expect to be able to prove the same at a hearing held in this matter. I understand that the statements herein are made subject to the penalties of 18 Pa. C.S. § 4904 (relating to unsworn falsification to authorities).

Date: 12-19-2013

Linda M. Vashlishan
(Signature)

EXHIBIT "A"

The public utilities, municipalities, counties, corporations, and property owners concerned in, or affected by, the proposed crossing alterations are:

Mr. Mark Chappell, Chief
ROW and Utility Division PennDot Bureau of
Design
PO Box 3362
Harrisburg, PA 17105-3362

Ms. Gina M. D'Alfonso
Assistant Counsel in Charge
Department of Transportation
Office of Chief Counsel
9th Floor
PO Box 8212
Harrisburg, PA 17105-8212

Mr. Joe Strok
Grade Crossing Engineer
PennDot, District 4-0
55 Keystone Industrial Park
Dunmore, PA 18512

Mr. Paul Brancato
Railroad Owner
Stourbridge Railroad Company
c/o Ideal Steel Supply Company
10643 157th Street
Jamaica, NY 11433

Mr. Charles Jensen
Railroad Operator
Morristown & Erie Railway, Inc.
PO Box 2206
Morristown, NJ 07962-2206

Mr. Joe Schimitsch
Lackawaxen Telephone Company
PO Box 8
Rowland, PA 18457

Ms. Alice Muniz
Blue Ridge Communications
112 Bennett Avenue
Milford, PA 18337

Lackawaxen Township
169 Urban Road
Hawley, PA 18428

Mr. Rich Caridi
Chairman
Pike County Commissioners
506 Broad Street
Milford, PA 18337

Mrs. Margaret Alvarez
Right-of-Way Agent
PPL Electric Utilities
600 Larch Street
Scranton, PA 18509

RECEIVED

JAN 28 2014

PA PUBLIC UTILITY COMMISSION
SECRETARY'S BUREAU

THIS DRAWING IS THE PROPERTY OF PPL ELECTRIC UTILITIES AND CONTAINS PROPRIETARY AND CONFIDENTIAL INFORMATION WHICH MUST NOT BE DUPLICATED, USED OR DISCLOSED WITHOUT WRITTEN AUTHORIZATION FROM PPL ELECTRIC UTILITIES.

3-477, 37 STRD. H.D. AL., 80MILS XLP CONDRS. (12KV)

1-4/0, G/I STRD. ACSR, NEUTRAL

MAX. SAG TEMP.
CONDRS. = 193° F (89° C)
OHGW = 227° F (108° C)

1-50'-CL.-3, WOOD POLE
75647/N49133

1-50'-CL.-3, WOOD POLE
75643/N49151

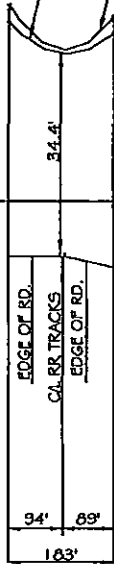

PROFILE:
SCALE: 1" = 200' HORIZ.
1" = 20' VERT.

RECEIVED
JAN 28 2014
PA PUBLIC UTILITY COMMISSION
SECRETARY'S BUREAU

TECHNICAL UTILITY SERVICES
JAN 21 2013
PA PUBLIC UTILITY COMMISSION
BUREAU OF

PLAN:
SCALE: 1" = 100'

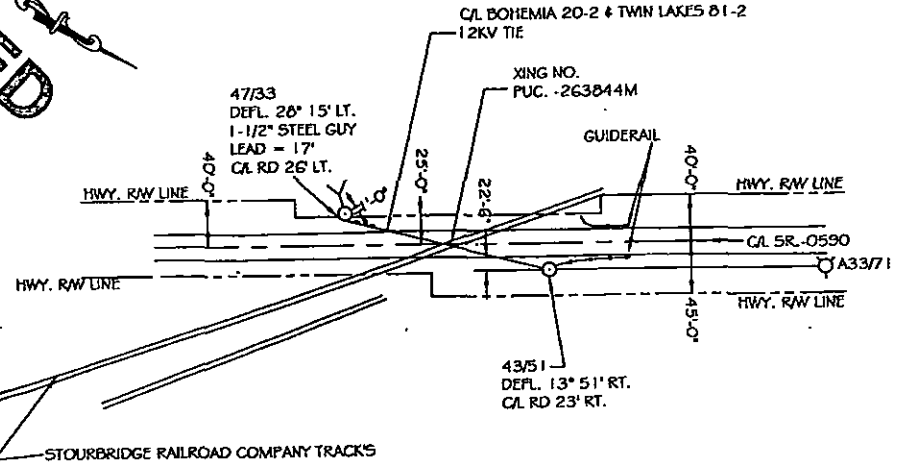

ACCT- 200192		BOHEMIA 20-2 AND TWIN LAKES 81-2 12KV TIE LINES	
SCALE- AS SHOWN		PLAN SHOWING ELECTRIC UTILITIES OVER	
BY- CDW		STOURBRIDGE RAILROAD COMPANY TRACKS	
MJS		AT PUC. CROSSING NO. 263844M	
JMD		LACKAWAXEN TWP. PIKE CO., PA.	
CEII Confidential		APPROVED	DATE
AC	PPL DRAWING NO.	PPL ELECTRIC UTILITIES	
CAD ID	EU00503859	SHEET NO.	REV.
		1	0

REVISION 1

NO.	DATE	ACCT.	REVISION	BY	REVIEWED	APPROVED

P155 LOCATION CODES
756-491-N1 PLAN & PROFILE
756-491-N1 FACILITY MAP



PC CAD

Crossings County

Results

Map Contents

- FRASafety
 - Zip Codes
 - All Populated Places
 - Population 50 to 500 Thousand
 - Major Cities
 - Population Under 50 Thousand
 - Mileposts
 - Grade Crossing
 - Amtrak Stations
 - Freight Stations
 - STRACNET & Connectors
- CN: Canadian National
- CPRS: Canadian Pacific
- CSXT: CSX Transportation
- KCS: Kansas City Southern
- NS: Norfolk Southern
- UP: Union Pacific
- Rail: CN & MX
- Rail US
- Rail Non - Main Lines
- Rail - Abandon
- Rail Main Lines
- FRA Subdivision
- Major Highways
- Secondary Highways
- Streets
- Waterways

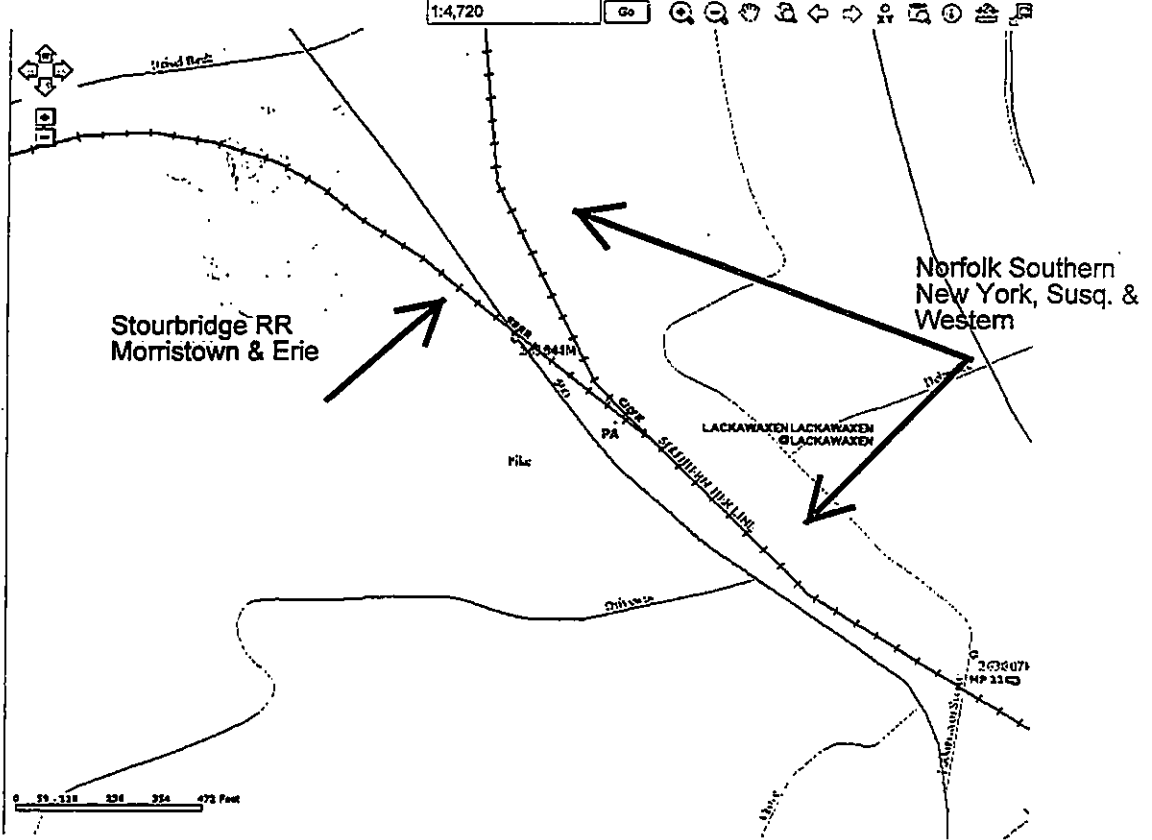

PA PUBLIC UTILITY COMMISSION
SECRETARY'S BUREAU

JAN 28 2014

RECEIVED

PA PUBLIC UTILITY COMMISSION
BUREAU OF
JAN 21 2013
TECHNICAL UTILITY SERVICES
RAIL SECTION

CERTIFICATE OF SERVICE

I, Linda M. Vashlishan, Supervisor – Right of Way of PPL Electric Utilities Corporation hereby certify that I have this day served a true copy of the foregoing document upon the participants, listed below, in accordance with the requirements of § 1.54

Mr. Mark Chappell, Chief
ROW and Utility Division PennDot Bureau of Design
PO Box 3362
Harrisburg, PA 17105-3362

Ms. Gina M. D'Alfonso
Assistant Counsel in Charge
Department of Transportation
Office of Chief Counsel
9th Floor
PO Box 8212
Harrisburg, PA 17105-8212

Mr. Joe Strok
Grade Crossing Engineer
PennDot, District 4-0
55 Keystone Industrial Park
Dunmore, PA 18512

Mr. Paul Brancato
Railroad Owner
Stourbridge Railroad Company
c/o Ideal Steel Supply Company
10643 157th Street
Jamaica, NY 11433

Mr. Charles Jensen
Railroad Operator
Morristown & Erie Railway, Inc.
PO Box 2206
Morristown, NJ 07962-2206

Mr. Joe Schimitsch
Lackawaxen Telephone Company
PO Box 8
Rowland, PA 18457

Ms. Alice Muniz
Blue Ridge Communications
112 Bennett Avenue
Milford, PA 18337

Lackawaxen Township
169 Urban Road
Hawley, PA 18428

Mr. Rich Caridi
Chairman
Pike County Commissioners
506 Broad Street
Milford, PA 18337

Mrs. Margaret Alvarez
Right-of-Way Agent
PPL Electric Utilities
600 Larch Street
Scranton, PA 18509

PA PUBLIC UTILITY COMMISSION
SECRETARY'S BUREAU

JAN 28 2014

RECEIVED

Dated this 19th day of DECEMBER, 2013.

Linda M. Vashlishan
(Signature)