

March 4, 2014

Rosemary Chiavetta, Secretary  
Pennsylvania Public Utility Commission  
P.O. Box 3265  
Harrisburg, PA 17105-3265

RECEIVED

MAR - 4 2014

RE: Docket No. ~~C-2014~~ Pine-Roe Natural Gas Company

C-2014-2400485

PA PUBLIC UTILITY COMMISSION  
SECRETARY'S BUREAU

Ms. Rosemary Chiavetta, Secretary

In regards to the background finding we have had the following items done after the inspection to ensure that Pine-Roe is in compliance with all the safety codes that are currently in place with the Commission.

13. – We now have an “operator IS and will be filing the DOT reports each year when they are due.

We also have contacted Mr. Gourley who will be checking the odorant levels with the correct instruments and this will be documented from this point forward. Mr. Gourley will also be conducting the leak survey using the correct instruments instead of us currently walking the lines on a yearly basis and watching for dead vegetation. On Tuesday, March 4, 2014, Mr. Gourley did the odorant test on Pine-Roe Gas lines.

Mr. Habjan will be inspecting each emergency valve during the summer months every year and this will be documented with the date and time that they were inspected. He will be using the forms that are submitted in this packet.

19 a. The line markers have been replaced that were not legible and the ones that were missing, new ones were added. We were changing the information on them every 2 years. They will now be changed every year to alleviate the fading of the information on them.

b. The pipeline that is exposed to the atmosphere is inspected monthly when the meters are read. Mr. Habjan or I personally read the meters every month and during that time the pipe that is exposed is inspected by us. This will start to be documented that it is being done on a regular basis.

c. During the summer of 2014 all the exposed pipeline will be painted. When the weather starts to get warmer the pipe will be painted with a coating that is suitable to prevent atmospheric corrosion.

d. The integrity program is all written and it is enclosed in the packet. This was completed shortly after Mr. Geibel left. We had Mr. Steve Hurbank assistant in getting all the information together and getting it correct for the Commission.

f. The patrolling of the lines will be documented. It is walked every summer and most of the lines are walked while reading the meters. We will be documenting the lines when they are walked and looking for leaks or problems.

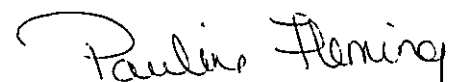
h. We do have maps of our lines showing all the information that was required. I am not sure why this information was not given to Mr. Geibel. The maps are kept in Mr. Habjan's office at all times. We have never had an issue with our maps at any other time that we have been inspected and they have remained the same for years now. Our pipelines have not changed in years. All the crossing and emergency valve as marked on it as well. A copy of the map is also included in this packet.

21. All the violations that Mr. Geiebl had on his form were completed on a timely basis. I am sorry that NC-51-13 form was not completed but the violations that were on the form were all completed and what we believe are up to the standards of the Commission.

In regards to the assessment reports I contacted Ms. Wimer on March 26, 2013 she informed me that I could not file late assessment and that I already paid the assessment fees but that I would need to file them by March 31, 2014 which I plan on doing.

We are asking for a decrease in the fines that were assessed with the letter. We feel that we are now in compliance with all of the items that were discussed and needed to be addressed. We are a small utility company and cannot afford to pay a fine of that magnitude. We will be keeping up with our reporting and filing of all PUC requested documents. If there is any other questions that you have or if there is anything else that you need please contact me so that it can be taken care of. The best way to reach me is by email [FLEMING1170@YAHOO.COM](mailto:FLEMING1170@YAHOO.COM). I go through my emails all through the day and in the evening at home.

Sincerely,

A handwritten signature in cursive script that reads "Pauline Fleming".

Pauline Fleming

CC: Stephanie Wimer

# **DISTRIBUTION INTEGRITY MANAGEMENT PLAN**

**For Pine Roe Natural Gas**

**RECEIVED**

**P.O. Box 146  
Clarion, Pennsylvania 16214**

MAR - 4 2014

PA PUBLIC UTILITY COMMISSION  
SECRETARY'S BUREAU

**Generated Date: 2013-09-28 Version: 2.1.1  
Effective Date: 2013-09-28 Replaces Version:  
none Effective: (No Prior Plan)**

**Emergency Plan**

**Operation and Maintenance Plan**

**Small Operator Guide**

**Inspection Forms**

---

**DISTRIBUTION INTEGRITY MANAGEMENT PLAN: For Pine Roe  
Natural Gas**

**P.O. Box 146  
Clarion, Pennsylvania 16214**

**Generated Date: 2013-09-28 Version: 2.1.1 Effective Date: 2013-09-  
28 Replaces Version: none Effective: (No Prior Plan)**

**RECEIVED**

**MAR - 4 2014**

**PA PUBLIC UTILITY COMMISSION  
SECRETARY'S BUREAU**

---

---

# Table of Contents

Revisions .....	iv
1. SCOPE .....	1
2. DEFINITIONS .....	2
3. KNOWLEDGE OF THE DISTRIBUTION SYSTEM .....	3
4. THREAT ASSESSMENT .....	4
4.1. Overview .....	4
4.2. Pine Roe Natural Gas Threat Assessment .....	4
4.2.1. Corrosion .....	4
4.2.2. Equipment Malfunctions .....	6
4.2.3. Excavation Damage .....	7
4.2.4. Incorrect Operations .....	8
4.2.5. Materials, Welds and Joints .....	8
4.2.6. Natural forces .....	9
4.2.7. Other outside forces .....	9
4.2.8. Other threats .....	9
5. RISK EVALUATION AND PRIORITIZATION ..	10
5.1. Overview .....	10
5.2. Pine Roe Natural Gas Section Risk Ranking ..	10
6. ADDITIONAL/ACCELERATED MEASURES TO ADDRESS RISKS ..	12
6.1. MANDATORY ADDITIONAL ACTIONS ..	12
6.2. RISK BASED ADDITIONAL ACTIONS .....	15
7. MEASURE PERFORMANCE, MONITOR RESULTS AND EVALUATE EFFECTIVENESS	16
7.1. MANDATORY PERFORMANCE MEASURES .....	16
7.2. RISK BASED PERFORMANCE MEASURES .....	16
7.3. MONITOR RESULTS AND EVALUATE EFFECTIVENESS .....	16
8. PERIODIC EVALUATION AND IMPROVEMENT .....	18
9. REPORTING .....	19
10. RECORD KEEPING .....	21
11. ATTACHMENTS .....	22
11.1. IMPLEMENTATION PLAN .....	22
11.2. LIST OF ANSWERS AND DATA SOURCES FROM SHRIMP™ INTERVIEWS ..	24
11.3. DESCRIPTION OF THE PROCESS FOLLOWED TO DEVELOP THIS PLAN ..	40
11.3.1. Process Description .....	40
11.3.2. Relative Risk-Model .....	48
12. REFORMAT TEMPLATE Heading 1 .....	53
12.1. REFORMAT TEMPLATE Heading 2 .....	53
12.1.1. REFORMAT TEMPLATE Heading 3 ..	53

RECEIVED

MAR - 4 2014

PA PUBLIC UTILITY COMMISSION  
SECRETARY'S BUREAU

# Revisions

**Table 1. Plan Version History**

Plan Version	Program Version	Date	By User	Notes
2.1.1	2.1.10	2013-09-28	JHabjan	2.1.2

**Table 2. SHRIMP Version History**

Program Version	Date	Notes
2.1.10	2013-07-28	Allow limited changes to Required Settings during Correct mode. Allow direct switch from correct mode to revise mode.
2.1.9	2013-07-09	Correct problem with AA-AC-02 and AA-EC-6a; they had spaces in their lids.
2.1.8	2013-04-25	Modified Threat Assessment wording. Added capability for referencing external sources of information.
2.1.7	2013-02-25	May choose from multiple Plan Years. Detects leak trend changes when Plan Year changed. Updated Relative Risk Model description.
2.1.6	2013-01-02	Data for 2012 may now be entered.
2.1.5	2012-12-13	Corrects crashes due to certain revision notes; Shows plan type (preview or final) in list of Written Plans.
2.1.4	2012-12-02	Corrects prior plan effective date; interview end during review or correct modes; required settings.
2.1.3	2012-11-28	Fix problem with editable areas when using "Correct" mode.
2.1.2	2012-11-18	SHRIMP update adding New Leaks mode and new Required Settings.
2.1.1	2012-04-24	Initial release of SHRIMP with full DIMP version tracking and revisions.
1.1.31	2012-04-24	All versions of SHRIMP prior to the incorporation of version tracking.

RECEIVED

MAR - 4 2014

PA PUBLIC UTILITY COMMISSION  
SECRETARY'S BUREAU

---

# Chapter 1. SCOPE

This document is the distribution integrity management plan (Plan) for Pine Roe Natural Gas. It is intended to meet the requirements of 49 CFR Part 192, Subpart P Distribution Integrity Management Programs (DIMP).

This Plan covers the Pine Roe Natural Gas is a low pressure distribution system with customer services regulators install at each service which requires no other over pressure protection. of Pine Roe Natural Gas.

This Plan is effective on 2013-09-28.

This Plan is Version 2.1.1.

This Plan replaces Version none.

This Plan is based on data for the Plan Year ending 2012.

The following people are responsible for ensuring that the requirements of this Plan are carried out:

**Table 1.1. Responsible Parties**

<b>Name and/or Job Title</b>	<b>Responsible For</b>
John Habjan/President and Owner	All O&M, and DIMP responsibilities.

In addition, assignments for implementing action items found in this Plan are listed in Section 11.1, "IMPLEMENTATION PLAN".

RECEIVED

MAR - 4 2014

PA PUBLIC UTILITY COMMISSION  
SECRETARY'S BUREAU

---

## Chapter 2. DEFINITIONS

- Excavation damage** Any impact that results in the need to repair or replace an underground facility due to a weakening, or the partial or complete destruction, of the facility, including, but not limited to, the protective coating, lateral support, cathodic protection or the housing for the line device or facility.
- Excavation ticket** All receipts of information by the operator from the ONE-CALL notification center requesting marking of the location of gas pipeline facilities.
- Hazardous Leak** A leak that represents an existing or probable hazard to persons or property and requires immediate repair or continuous action until the conditions are no longer hazardous. Examples include:
- Escaping gas that has ignited.
  - Any indication of gas which has migrated into or under a building, or into a tunnel,
  - Any reading at the outside wall of a building, or where gas would likely migrate to an outside wall of a building,
  - Any reading of 80% LEL, or greater, in a confined space,
  - Any reading of 80% LEL, or greater in small substructures (other than gas associated substructures) from which gas would likely migrate to the outside wall of a building,
  - Any leak that can be seen, heard, or felt, and which is in a location that may endanger the general public or property, or
  - Any leak which, in the judgment of operating personnel at the scene, is regarded as an immediate hazard.

RECEIVED

MAR - 4 2014

PA PUBLIC UTILITY COMMISSION  
SECRETARY'S BUREAU

---

# Chapter 3. KNOWLEDGE OF THE DISTRIBUTION SYSTEM

This Plan was developed based on the design, construction, operation and maintenance records of Pine Roe Natural Gas, including: incident and leak history, corrosion control records, continuing surveillance records, patrolling records, maintenance history, and excavation damage experience, as well as the judgment and knowledge of Pine Roe Natural Gas' employees. The specific elements of knowledge of the infrastructure used to evaluate each threat and prioritize risks are listed in Chapter 4, *THREAT ASSESSMENT*, Chapter 5, *RISK EVALUATION AND PRIORITIZATION* and Section 11.2, "LIST OF ANSWERS AND DATA SOURCES FROM SHRIMP™ INTERVIEWS" of this Plan. Section 11.2, "LIST OF ANSWERS AND DATA SOURCES FROM SHRIMP™ INTERVIEWS" also lists the data sources used to answer each question.

Any additional information needed and the plan for gaining this currently unknown information over time through normal activities is described in Section 11.1, "IMPLEMENTATION PLAN".

The processes used for Threat Evaluation and Risk Prioritization are the processes found in the Simple, Handy, Risk-based Integrity Management Plan™ (SHRIMP™) software package developed by the APGA Security and Integrity Foundation (SIF). SHRIMP™ uses an index model developed by the consultants and advisors of the SIF. Threat assessment is performed using questions developed by the Gas Piping Technology Committee (GPTC) as modified and added to by the SHRIMP™ advisors. A description of the process followed is included in Section 11.3, "DESCRIPTION OF THE PROCESS FOLLOWED TO DEVELOP THIS PLAN".

This Plan will be reviewed at least every 1 year to continually refine and improve this Plan. Reviews may be performed more frequently as described in Chapter 8, *PERIODIC EVALUATION AND IMPROVEMENT* of this Plan.

Records for all piping system installed after the effective date of this Plan will be captured and retained by Pine Roe Natural Gas. This will include the location where new piping and appurtenances are installed and the material of which they are constructed. The manner in which this will be accomplished is described in Section 11.1, "IMPLEMENTATION PLAN".

RECEIVED

MAR - 4 2014

PA PUBLIC UTILITY COMMISSION  
SECRETARY'S BUREAU

# Chapter 4. THREAT ASSESSMENT

MAR - 4 2014

PA PUBLIC UTILITY COMMISSION  
SECRETARY'S BUREAU

## 4.1. Overview

The following threats were evaluated on the distribution piping covered under the scope of this Plan: corrosion, natural forces, excavation damage, other outside force damage, material, weld or joint failure (including compression coupling), equipment malfunction, incorrect operation, and any other concerns that could threaten the integrity of the pipeline. The results of these threat assessments are discussed in the following sections. Answers to all questions asked by SHRIMP and the data sources for those answers is found in Section 11.2, "LIST OF ANSWERS AND DATA SOURCES FROM SHRIMP™ INTERVIEWS".

In addition to Pine Roe Natural Gas's own information, data from the following external sources were used to assist in identifying potential threats:

- PHMSA advisory bulletins, regulatory updates and other integrity management information sent to SHRIMP subscribers by the APGA Security and Integrity Foundation;
- PHMSA Annual and Incident Report data, used in calculating the incident probability factor in the risk ranking model, described in more detail in Section 11.3.2, "Relative Risk Model".
- Data on leak repair rates, excavation damages per 1000 locate tickets and other aggregated data from all SHRIMP users provided by the APGA SIF to SHRIMP subscribers
- Information provided through membership and/or active participation in the following organizations:

None.

## 4.2. Pine Roe Natural Gas Threat Assessment

### 4.2.1. Corrosion

#### Atmospheric Corrosion

Atmospheric corrosion was determined not to be a threat warranting further consideration for additional action beyond code compliance or current system practice because:

- Inspections have not found metal loss due to atmospheric corrosion over the past 5 years.
- Leaks caused by atmospheric corrosion have not required repair over the past 5 years.
- Inspections have not found problems with above ground pipe coatings that could not be fixed by routine maintenance

#### External Corrosion On Coated, Cathodically Protected, Steel Mains And Services

External corrosion on coated, cathodically protected, steel mains and services was determined not to be a threat warranting further consideration for additional action beyond code compliance or current system practice because:

- coated, cathodically protected, steel mains and services are not present.

## **External Corrosion On Bare, Cathodically Protected, Steel Mains And Services**

External corrosion on bare, cathodically protected, steel mains and services was determined not to be a threat warranting further consideration for additional action beyond code compliance or current system practice because:

- bare, cathodically protected, steel mains and services are not present.

## **External Corrosion On Coated, Unprotected, Steel Mains And Services**

External corrosion on coated, unprotected, steel mains and services was determined not to be a threat warranting further consideration for additional action beyond code compliance or current system practice because:

- coated, unprotected, steel mains and services are not present.

## **External Corrosion On Bare, Unprotected, Steel Mains And Services**

External corrosion on bare, unprotected, steel mains and services was determined not to be a threat warranting further consideration for additional action beyond code compliance or current system practice because:

- bare, unprotected, steel mains and services are not present.

## **External Corrosion On Cast, Wrought, Ductile Iron Mains And Services (8" Or Smaller)**

External corrosion on cast, wrought, ductile iron mains and services (8" or smaller) was determined not to be a threat warranting further consideration for additional action beyond code compliance or current system practice because:

- cast, wrought, ductile iron mains and services (8" or smaller) are not present.

## **External Corrosion On Plastic Mains And Services With Metal Fittings**

External corrosion on plastic mains and services with metal fittings was determined not to be a threat warranting further consideration for additional action beyond code compliance or current system practice because:

- Leaks on metallic fittings are not increasing.
- Exposed pipe inspections do not indicate a corrosion problem.

## **External Corrosion On Other Metal**

External corrosion on other metal was determined not to be a threat warranting further consideration for additional action beyond code compliance or current system practice because:

- other metal is not present.

## **External Corrosion On Cast, Wrought, Ductile Iron Mains And Services (larger Than 8")**

External corrosion on cast, wrought, ductile iron mains and services (larger than 8") was determined not to be a threat warranting further consideration for additional action beyond code compliance or current system practice because:

- cast, wrought, ductile iron mains and services (larger than 8") are not present.

## **Internal Corrosion**

Internal corrosion was determined not to be a threat warranting further consideration for additional action beyond code compliance or current system practice because:

- neither metal mains and services nor plastic mains and services with metal fittings are present.

## **4.2.2. Equipment Malfunctions**

### **Equipment Malfunctions**

Equipment malfunctions was determined not to be a threat warranting further consideration for additional action beyond code compliance or current system practice because:

- Leaks are not occurring and inspections do not indicate potential equipment malfunctions.
- System does not contain equipment known/prone to malfunction (Industry wide).

### **Equipment Malfunctions Due To Failing Valves**

Equipment malfunctions due to failing valves was determined not to be a threat warranting further consideration for additional action beyond code compliance or current system practice because:

- failing valves are not present.

### **Equipment Malfunctions Due To Failing Regulators/relief Valves**

Equipment malfunctions due to failing regulators/relief valves was determined not to be a threat warranting further consideration for additional action beyond code compliance or current system practice because:

- failing regulators/relief valves are not present.

### **Equipment Malfunctions Due To Failing Other Equipment**

Equipment malfunctions due to failing other equipment was determined not to be a threat warranting further consideration for additional action beyond code compliance or current system practice because:

- failing other equipment are not present.

### **Equipment Malfunctions Due To Valves Prone To Failure**

Equipment malfunctions due to valves prone to failure was determined not to be a threat warranting further consideration for additional action beyond code compliance or current system practice because:

- valves prone to failure are not present.

## **Equipment Malfunctions Due To Regulators / Relief Valves Prone To Failure**

Equipment malfunctions due to regulators / relief valves prone to failure was determined not to be a threat warranting further consideration for additional action beyond code compliance or current system practice because:

- regulators / relief valves prone to failure are not present.

## **Equipment Malfunctions Due To Other Equipment Prone To Failure**

Equipment malfunctions due to other equipment prone to failure was determined not to be a threat warranting further consideration for additional action beyond code compliance or current system practice because:

- other equipment prone to failure are not present.

### **4.2.3. Excavation Damage**

#### **Excavation Damage Due To Concentrated Damages Or Tickets**

Excavation damage due to concentrated damages or tickets was determined not to be a threat warranting further consideration for additional action beyond code compliance or current system practice because:

- There are no areas with concentrations of excavation damages.
- There are no areas with concentrations of locate tickets.

#### **Excavation Damage Due To Your Crew Or Contractor Damages**

Excavation damage due to your crew or contractor damages was determined not to be a threat warranting further consideration for additional action beyond code compliance or current system practice because:

- Excavation damage has not been caused by operator's crews or contractors.

#### **Excavation Damage Due To Third Party Damages**

Excavation damage due to third party damages was determined not to be a threat warranting further consideration for additional action beyond code compliance or current system practice because:

- Excavation damages have not occurred due to third parties during the past few years.

#### **Excavation Damage Due To Blasting Damage**

Excavation damage due to blasting damage was determined not to be a threat warranting further consideration for additional action beyond code compliance or current system practice because:

- No portions of the system are located where excavation in the area of pipeline would require the use of explosives.
- No portions of the system are in known areas of blasting or demolition activity, such as rock quarries or coal mining,
- No damage has occurred due to blasting.

## 4.2.4. Incorrect Operations

### Incorrect Operations Due To Inadequate Procedures

Incorrect operations due to inadequate procedures was determined not to be a threat warranting further consideration for additional action beyond code compliance or current system practice because:

- Failures due to inadequate procedures are not increasing per year.

### Incorrect Operations Due To Failure To Follow Procedures

Incorrect operations due to failure to follow procedures was determined not to be a threat warranting further consideration for additional action beyond code compliance or current system practice because:

- failures due to a failure to follow procedures have not been experienced.

### Incorrect Operations Due To Operator Qualification Revocation

Incorrect operations due to operator qualification revocation was determined not to be a threat warranting further consideration for additional action beyond code compliance or current system practice because:

- no employees or contractors have had operator qualification credentials revoked due to poor performance of any covered task.

### Incorrect Operations Due To Drugs And Alcohol

Incorrect operations due to drugs and alcohol was determined not to be a threat warranting further consideration for additional action beyond code compliance or current system practice because:

- no employees or contractors tested positive for drugs or alcohol (other than pre-hire tests).

## 4.2.5. Materials, Welds and Joints

### Material, Weld Or Joint

Material, weld or joint was determined to be a threat warranting further consideration for additional action beyond code compliance or current system practice because:

- Materials with known problems are in use.

The possible consequences of a failure of this portion due to the indicated threat are:

- Reason could not be determined.

### Material, Weld Or Joint Due To Manufacturing Defects

Material, weld or joint due to manufacturing defects was determined not to be a threat warranting further consideration for additional action beyond code compliance or current system practice because:

- manufacturing defects on pipe or non-pipe components have not been experienced.

### Material, Weld Or Joint Due To Workmanship Defects

Material, weld or joint due to workmanship defects was determined not to be a threat warranting further consideration for additional action beyond code compliance or current system practice because:

- failures due to workmanship defects have not been experienced.

## **Material, Weld Or Joint Due To Known Problem Materials**

Material, weld or joint due to known problem materials was determined not to be a threat warranting further consideration for additional action beyond code compliance or current system practice because:

- none of the known problem materials exist in the system.

## **4.2.6. Natural forces**

### **Natural Forces**

Natural forces was determined to be a threat warranting further consideration for additional action beyond code compliance or current system practice because:

- Leaks, failures or damages are averaging one (1) or more per year.
- Natural forces have caused leaks, failures or damages to steel or plastic pipeline in the system/section.

The possible consequences of a failure of this portion due to the indicated threat would be about the same as for the Pine Roe Natural Gas system in general.

## **4.2.7. Other outside forces**

### **Other Outside Forces**

Other outside forces was determined not to be a threat warranting further consideration for additional action beyond code compliance or current system practice because:

- Leaks, failures or damages are not averaging one (1) or more per year.

## **4.2.8. Other threats**

### **Other Threats**

Other threats was determined not to be a threat warranting further consideration for additional action beyond code compliance or current system practice because:

- Reason could not be determined. Please contact administrator.

# Chapter 5. RISK EVALUATION AND PRIORITIZATION

## 5.1. Overview

Of the sections identified during the Threat Assessment as requiring further consideration for additional actions, Pine Roe Natural Gas has determined that the relative risk of these threats to the integrity of these lines ranks in the following priority, beginning with the highest relative risk.

RANK indicates the final relative risk rank after review and validation by Pine Roe Natural Gas.

USER RANK indicates if the threat-segment was re-ranked by Pine Roe Natural Gas. A zero indicates it was left where SHRIMP's risk model ranked it – any other number indicates it was moved higher or lower by Pine Roe Natural Gas. Where a threat-segment was re-ranked an explanation for the reason is included in the discussion for that segment.

SHRIMP Rank is where SHRIMP's risk ranking model originally ranked the threat-segment. Segments under Other Threats were not ranked by SHRIMP so are initially placed at the bottom of the segment list. Pine Roe Natural Gas has placed these segments in the risk ranking list based in its knowledge and judgment.

Relative Risk score is a numeric score from 0-30 based on the four factors listed – Probability, Consequence, Leak Cause Factor and Incident Probability Factor. The risk model is described in detail in Section 11.3.2, "Relative Risk Model".

The risk ranking is based on relative risk, not absolute risk. It should not be construed to suggest that the highest ranked segment is unsafe or that additional actions are required to maintain public safety. It is merely a tool to assist Pine Roe Natural Gas to prioritize its inspection and maintenance programs.

## 5.2. Pine Roe Natural Gas Section Risk Ranking

### a. Section: Pine Roe Natural Gas

**Threat:** Natural Forces

**Description:** Pine Roe Natural Gas is a low pressure distribution system with customer services regulators install at each service which requires no other over pressure protection.

**Table 5.1.**

Rank	User Rank	SHRIMP Rank	Relative Risk Score	Probability Score	Consequence Score	Leak Cause Factor	Incident Probability Factor
1	0	1	4.44	3.37	1	1.053	1.25
No Previous Plan							

Ranked here, in part, for the following reasons:

- Natural forces have caused leaks, failures or damages to steel or plastic pipeline in the system/section.
- Leaks, failures or damages are averaging one (1) or more per year.

RECEIVED

### b. Section: Pine Roe Natural Gas

MAR - 4 2014

RISK EVALUATION AND  
PRIORITIZATION

---

**Threat:** Material, Weld or Joint Failure

**Description:** Pine Roe Natural Gas is a low pressure distribution system with customer services regulators install at each service which requires no other over pressure protection.

**Table 5.2.**

Rank	User Rank	SHRIMP Rank	Relative Risk Score	Probability Score	Consequence Score	Leak Cause Factor	Incident Probability Factor
2	0	2	0	0	1	1.1	1.00
No Previous Plan							

Ranked here, in part, for the following reasons:

- Reason could not be determined.

# Chapter 6. ADDITIONAL/ACCELERATED MEASURES TO ADDRESS RISKS

## 6.1. MANDATORY ADDITIONAL ACTIONS

The following are mandatory additional actions required by DIMP regulations.

### LEAK CLASSIFICATION AND ACTION CRITERIA

These leak classification and action criteria are taken from the Guide for Gas Transmission and Distribution Piping Systems, 2003 edition. A complete copy of the GPTC Guide can be purchased at [www.aga.org](http://www.aga.org).

**Table 6.1. Leak Classification And Action Criteria - Grade 1**

LEAK CLASSIFICATION AND ACTION CRITERIA – GRADE 1		
Grade Definition	Examples	Action Criteria
A leak that represents an existing or probable hazard to persons or property, and requires immediate repair or continuous action until the conditions are no longer hazardous. See §192.703(c).	<ol style="list-style-type: none"> <li>1. Any leak which, in the judgment of operating personnel at the scene, is regarded as an immediate hazard.</li> <li>2. Escaping gas that has ignited.</li> <li>3. Any indication of gas which has migrated into or under a building, or into a tunnel.</li> <li>4. Any reading at the outside wall of a building, or where gas would likely migrate to an outside wall of a building.</li> <li>5. Any reading of 80% LEL, or greater, in a confined space.</li> <li>6. Any reading of 80% LEL, or greater in small substructures (other than gas associated substructures) from</li> </ol>	<p>Requires prompt action* to protect life and property, and continuous action until the conditions are no longer hazardous</p> <p>* The prompt action in some instances may require one or more of the following:</p> <ol style="list-style-type: none"> <li>a. Implementation of emergency plan (§192.615).</li> <li>b. Evacuating premises.</li> <li>c. Blocking off an area.</li> <li>d. Rerouting traffic.</li> <li>e. Eliminating sources of ignition.</li> <li>f. Venting the area by removing manhole covers, barholing, installing vent holes, or other means.</li> <li>g. Stopping the flow of gas by closing valves or other means.</li> </ol>

RECEIVED

MAR - 4 2014

PA PUBLIC UTILITY COMMISSION  
SECRETARY'S BUREAU

**LEAK CLASSIFICATION AND ACTION CRITERIA – GRADE 1**

Grade Definition	Examples	Action Criteria
	<p>which gas would likely migrate to the outside wall of a building.</p> <p>7. Any leak that can be seen, heard, or felt, and which is in a location that may endanger the general public or property.</p>	<p>h. Notifying police and fire departments.</p>

**Table 6.2. Leak Classification And Action Criteria - Grade 2**

**LEAK CLASSIFICATION AND ACTION CRITERIA – GRADE 2**

Grade Definition	Examples	Action Criteria
<p>A leak that is recognized as being non-hazardous at the time of detection, but justifies scheduled repair based on probable future hazard.</p>	<p>A. Leaks Requiring Action Ahead of Freezing or Adverse Venting Conditions.</p> <p>Any leak which, under frozen or other adverse soil conditions, would likely migrate to the outside wall of a building.</p> <p>B. Leaks Requiring Action Within Six Months</p> <p>1. Any reading of 40% LEL, or greater, under a sidewalk in a wall-to-wall paved area that does not qualify as a Grade 1 leak.</p> <p>2. Any reading of 100% LEL, or greater, under a street in a wall-to-wall paved area that has significant gas migration and does not qualify as a Grade 1 leak.</p>	<p>Leaks should be repaired or cleared within one calendar year, but no later than 15 months from the date the leak was reported. In determining the priority, criteria such as the following should be considered.</p> <p>a. Amount and migration of gas.</p> <p>b. Proximity of gas to buildings and subsurface structures.</p> <p>c. Extent of pavement.</p> <p>d. Soil type, and soil conditions, such as frost cap, moisture and natural venting.</p> <p>Grade 2 leaks should be reevaluated at least once every six months until cleared.</p>

ADDITIONAL/ACCELERATED  
MEASURES TO ADDRESS RISKS

LEAK CLASSIFICATION AND ACTION CRITERIA – GRADE 2		
Grade Definition	Examples	Action Criteria
	<p>3. Any reading less than 80% LEL in small substructures (other than gas associated substructures) from which gas would likely migrate creating a probable future hazard.</p> <p>4. Any reading between 20% LEL and 80% LEL in a confined space.</p> <p>5. Any reading on a pipeline operating at 30 percent SMYS, or greater, in a class 3 or 4 location, which does not qualify as a Grade 1 leak.</p> <p>6. Any reading of 80% LEL, or greater, in gas associated substructures.</p> <p>7. Any leak which, in the judgment of operating personnel at the scene, is of sufficient magnitude to justify scheduled repair.</p>	<p>The frequency of reevaluation should be determined by the location and magnitude of the leakage condition.</p>

**Table 6.3. Leak Classification And Action Criteria - Grade 3**

LEAK CLASSIFICATION AND ACTION CRITERIA – GRADE 3		
Grade Definition	Examples	Action Criteria
<p>A leak that is nonhazardous at the time of detection and can be reasonably expected to remain non-hazardous.</p>	<p>Leaks at Intervals</p> <p>1. Any reading of less than 80% LEL in small gas associated substructures.</p>	<p>Requiring These leaks should be reevaluated during the next scheduled survey, or within 15 months of the date reported, whichever occurs first, until the leak is regraded or no</p>

**LEAK CLASSIFICATION AND ACTION CRITERIA – GRADE 3**

Grade Definition	Examples	Action Criteria
	2. Any reading under a street in areas without wall-to-wall paving where it is unlikely the gas could migrate to the outside wall of a building.	longer results in a reading.
	3. Any reading of less than 20% LEL in a confined space.	

LEAK LOCATION PROCEDURE(S) Pine Roe Natural Gas has adopted leak location procedures which can be found at See Operation and Maintenance Plan.

## 6.2. RISK BASED ADDITIONAL ACTIONS

The following lists the additional/accelerated actions that will be taken and describes the part of Pine Roe Natural Gas to which each applies to address the priority risks described in the previous section of this Plan. Further details can be found in Section 11.1, "IMPLEMENTATION PLAN".

**a. Section: Pine Roe Natural Gas**

**Threat:** Natural Forces

**Description:** Pine Roe Natural Gas is a low pressure distribution system with customer services regulators install at each service which requires no other over pressure protection.

For **natural forces** on the **Pine Roe Natural Gas** section, Pine Roe Natural Gas will:

- The relative risk posed by this threat on this section of Pine Roe Natural Gas are adequately addressed by current inspection and maintenance. No additional actions are required. The following explanation was provided:

All outside forces are related to the weather in this region.

**b. Section: Pine Roe Natural Gas**

**Threat:** Material, Weld or Joint Failure

**Description:** Pine Roe Natural Gas is a low pressure distribution system with customer services regulators install at each service which requires no other over pressure protection.

For **material, weld or joint** on the **Pine Roe Natural Gas** section, Pine Roe Natural Gas will:

- The relative risk posed by this threat on this section of Pine Roe Natural Gas are adequately addressed by current inspection and maintenance. No additional actions are required. The following explanation was provided:

All joints are inspected in accordance with manufactures specifications. Pine Roe Natural believes no additional action is required.

---

# Chapter 7. MEASURE PERFORMANCE, MONITOR RESULTS AND EVALUATE EFFECTIVENESS

## 7.1. MANDATORY PERFORMANCE MEASURES

*Pine Roe Natural Gas will keep records of the following performance measures:*

1. The number of hazardous leaks either eliminated or repaired, categorized by cause;
2. The number of excavation damages;
3. The number of excavation tickets received;
4. The number of leaks either eliminated or repaired, categorized by cause; and
5. The number of hazardous leaks either eliminated or repaired, categorized by material.

RECEIVED

MAR - 4 2014

PA PUBLIC UTILITY COMMISSION  
SECRETARY'S BUREAU

## 7.2. RISK BASED PERFORMANCE MEASURES

The following lists the performance measures that will be tracked and describes the part of Pine Roe Natural Gas to which each applies to evaluate the effectiveness of the additional measures taken to address risks as described in the previous section of this Plan.

### a. Section: Pine Roe Natural Gas

**Threat:** Natural Forces

**Description:** Pine Roe Natural Gas is a low pressure distribution system with customer services regulators install at each service which requires no other over pressure protection.

For **natural forces** on the **Pine Roe Natural Gas** section, Pine Roe Natural Gas will:

- The relative risk posed by this threat on this section of Pine Roe Natural Gas does not warrant additional actions. Since no additional actions are called for there is no need for action-specific performance measures.

### b. Section: Pine Roe Natural Gas

**Threat:** Material, Weld or Joint Failure

**Description:** Pine Roe Natural Gas is a low pressure distribution system with customer services regulators install at each service which requires no other over pressure protection.

For **material, weld or joint** on the **Pine Roe Natural Gas** section, Pine Roe Natural Gas will:

- The relative risk posed by this threat on this section of Pine Roe Natural Gas does not warrant additional actions. Since no additional actions are called for there is no need for action-specific performance measures.

## 7.3. MONITOR RESULTS AND EVALUATE EFFECTIVENESS

MEASURE PERFORMANCE,  
MONITOR RESULTS AND  
EVALUATE EFFECTIVENESS

---

Monitoring results and evaluating effectiveness is addressed in Chapter 8, *PERIODIC EVALUATION AND IMPROVEMENT* of this Plan.

---

# Chapter 8. PERIODIC EVALUATION AND IMPROVEMENT

Pine Roe Natural Gas will conduct a complete re-evaluation of this Plan no less than every 1 year. Trends in each of the performance measures listed in Chapter 7, *MEASURE PERFORMANCE, MONITOR RESULTS AND EVALUATE EFFECTIVENESS* will be reviewed during the re-evaluation. If any performance measure indicates that any of the additional action taken is not effective in reducing the risk it is intended to address, Pine Roe Natural Gas will consider implementing additional actions to address that risk.

Re-evaluation of the Plan will also occur when changes occur on the system that may significantly change the risk of failure, including but not limited to:

- Completion of any additional actions listed in Chapter 6, *ADDITIONAL/ACCELERATED MEASURES TO ADDRESS RISKS* of this Plan,
- A review of performance measures concludes that a change of approach is warranted.

RECEIVED

MAR - 4 2014

PA PUBLIC UTILITY COMMISSION  
SECRETARY'S BUREAU

# Chapter 9. REPORTING

The following will be submitted annually to the Pipeline And Hazardous Materials Safety Administration (PHMSA) as part of the Distribution Annual Report (Form F7100.1-1) and Pennsylvania Public Utility Commission along with the distribution annual report.

## PERFORMANCE MEASURES

Pine Roe Natural Gas will track and report the following performance measures:

- Number of hazardous leaks either eliminated or repaired, categorized by cause;
- Number of excavation damages;
- Number of excavation tickets;
- Total number of leaks either eliminated or repaired, categorized by cause;

## EXCESS FLOW VALVES

Pine Roe Natural Gas will track the number of excess flow valves installed on the system

These data will be sent to the PHMSA Information Resource Manager as part of the Distribution Annual Report (Form F7100.1-1).

**MECHANICAL FITTING FAILURES** Pine Roe Natural Gas will track and report information relating to each hazardous leak resulting from the failure of a mechanical fitting. This information will include, at a minimum:

- location of the failure in the system,
- nominal pipe size,
- material type,
- nature of failure including any contribution of local pipeline environment,
- fitting manufacturer,
- lot number,
- date of manufacture, and
- any other information that can be found in markings on the failed fitting

Mechanical fitting failures will be sent to the PHMSA Information Resource Manager on the mechanical fitting failure report (Form 7100.1-2) either periodically as these failures occur or aggregated into one or more submissions made no later than March 15 of the following calendar year after the fitting failure(s).

Form 7100.1-1 and Form 7100.1-2 will be sent to the PHMSA Information Resource Manager via the online electronic reporting system available at PHMSA's home page at <http://phmsa.dot.gov>.

RECEIVED

MAR - 4 2014

PA PUBLIC UTILITY COMMISSION  
SECRETARY'S BUREAU

REPORTING

---

These data will also be sent to the Pennsylvania Public Utility Commission  
at:

Pennsylvania Public Utility Commission

Commonwealth Keystone Bldg.  
P O Box 3265  
Harrisburg, PA 17105-3265

---

# Chapter 10. RECORD KEEPING

The following records will be maintained for ten years.

1. This Plan,
2. Copies of previous written DIMP Plans,
3. Records of data required to be collected to calculate performance measures listed in Chapter 7, *MEASURE PERFORMANCE, MONITOR RESULTS AND EVALUATE EFFECTIVENESS*,
4. Records of mechanical fitting failures
5. Inspection, maintenance and other records relied upon in developing this written DIMP plan, as listed in the Data Source fields in Section 11.2, "LIST OF ANSWERS AND DATA SOURCES FROM SHRIMP™ INTERVIEWS" of this Plan.

RECEIVED

MAR - 4 2014

PA PUBLIC UTILITY COMMISSION  
SECRETARY'S BUREAU

# Chapter 11. ATTACHMENTS

MAR - 4 2014

## 11.1. IMPLEMENTATION PLAN

PA PUBLIC UTILITY COMMISSION  
SECRETARY'S BUREAU

This Attachment lists all the action items that are included in this written Distribution Integrity Management Plan.

Section A describes how Pine Roe Natural Gas will modify procedures, policies and/or recordkeeping systems to implement:

1. mandatory data collection and recordkeeping requirements in the regulation as listed in Section 7.1, "MANDATORY PERFORMANCE MEASURES" of this Plan, and
2. performance measures specific to Additional/Accelerated Actions as listed in Section 7.2, "RISK BASED PERFORMANCE MEASURES" of this Plan.

Section B describes how Pine Roe Natural Gas will implement Additional/Accelerated Actions, if any, listed in Chapter 6, *ADDITIONAL/ACCELERATED MEASURES TO ADDRESS RISKS* of this Plan.

Section C describes how Pine Roe Natural Gas will implement procedures to collect additional information needed to fill gaps, if any, found during the development of this Plan.

A. Procedures, policies and/or recordkeeping systems will be modified as follows to collect and retain information required to be collected and retained under the DIMP plan, including:

1. The following Recordkeeping tasks:

- a. Records for all piping system installed after the effective date of this Plan, including, at minimum, the location where new piping and appurtenances are installed and the material of which they are constructed.

Pine Roe Natural Gas will implement as follows:

Pine Roe Natural Gas is in the process of developing a computer data base to include all necessary forms for small operators as defined in the Guidance Manual for Operators of Small Natural Gas Systems provided by DOT PHMSA.

- b. Mechanical fitting failure data, including:

- i. location of the failure in the system,
- ii. nominal pipe size,
- iii. material type,
- iv. nature of failure including any contribution of local pipeline environment,
- v. fitting manufacturer,
- vi. lot number and date of manufacture, and
- vii. other information that can be found in markings on the failed fitting

Pine Roe Natural Gas will implement as follows:

Pine Roe Natural Gas will complete its survey and audit of company records no later than 30 December 2014.

2. The following mandatory Performance Measures:

- a. Number of hazardous leaks either eliminated or repaired as required by 49 CFR 192.703(c) (or total number of leaks if all leaks are repaired when found), categorized by cause.

Pine Roe Natural Gas will implement as follows:

Pine Roe Natural Gas repairs its leaks as found immediately.

- b. Number of excavation damages.

Pine Roe Natural Gas will implement as follows:

No projectd changes at this time.

- c. Number of excavation tickets (receipt of information by the underground facility operator from the notification center).

Pine Roe Natural Gas will implément as follows:

Pine Roe Natural Gas is a member of the Pennsylvania One Call System and will have the ability to access its excavation information thru the Member Web Access Portal.

- d. Total number of leaks either eliminated or repaired, categorized by cause.

Pine Roe Natural Gas will implement as follows:

Pine Roe Natural Gas will immediately report all leaks on small operator Form 12 A.

- e. Number of hazardous leaks either eliminated or repaired as required by Sec. 192.703(c) (or total number of leaks if all leaks are repaired when found), categorized by material;

Pine Roe Natural Gas will implement as follows:

Pine Roe Natural Gas repairs all leaks when found.

3. The following threat specific Performance Measures (presented by section in risk rank order):

B. Additional/Accelerated Actions included in this DIMP plan:

1. The following mandatory Accelerated/Additional Actions:

- a. Leak classification and action criteria as chosen and described in Section 6.1, "MANDATORY ADDITIONAL ACTIONS" of this Plan.

Pine Roe Natural Gas will implement as follows:

Pine Roe Natural Gas utilizes the Gas Piping Technology recommend practices for classifying its leaks. However Pine Roe Natural Gas repairs all leaks when found or reported.

2. The following threat specific Additional/Accelerated Actions (presented by section in risk rank order):

C. The following Procedures to collect additional information needed to fill gaps:

- a. Determine if materials with known problems are in use and which materials they are.

Pine Roe Natural Gas will implement as follows:

Employees will be instructed to inspect plastic piping whenever it is exposed and record the markings on the pipe and fittings. These markings will be compared to data on the SHRIMP website to determine if it is any of the materials identified in Advisory Bulletins from the Office of Pipeline Safety.

b. The following gaps identified by Pine Roe Natural Gas.

Pine Roe Natural Gas will implement as follows:

No additional information needed.

## 11.2. LIST OF ANSWERS AND DATA SOURCES FROM SHRIMP™ INTERVIEWS

The following lists the interview responses and data sources entered during the threat assessments.

### Corrosion Threat

- **Corrosion (CORR) (Pine Roe Natural Gas - Pine Roe Natural Gas is a low pressure distribution system with customer services regulators install at each service which requires no other over pressure protection.)**

- Interview Start (CORR)

Your Choice (weight: 0) --Continue

- How many leak repairs resulting from corrosion occurred during the years shown? (CORR-Leak)

Your Choice (weight: 0) --

**Table 11.1. Leak Repairs From PHMSA 7100.1-1**

End of Year	Corrosion		Totals	
	Mains	Services	Mains	Services
In 2008	0	0	0	0
In 2009	0	0	0	0
In 2010	0	0	0	0
In 2011	0	0	0	0
In 2012	0	0	0	0

- Review/Edit the data or Keep as is.

Review The Guidance and Choose (ECMETALNO)

Your Choice (weight: 0) --Keep

- Review/Edit the data or Keep as is.

Review The Guidance and Choose (ECPLASYES)

Your Choice (weight: 0) --Keep

- Does your plastic system contain isolated metallic fittings? (EC110)

Your Choice (weight: 0) --Yes

- Provide Additional Information (EC101b)

*Data Source:*

Atmospheric Corrosion Control Inspect reports Form 13 of the small operators guide are completed when conduction meter reading and patrolling.

Your Choice (weight: 0) --

- **Atmospheric Corrosion (CORRAC) (Pine Roe Natural Gas - Pine Roe Natural Gas is a low pressure distribution system with customer services regulators install at each service which requires no other over pressure protection.)**

- Interview Start (CORRAC)

Your Choice (weight: 0) --Continue

- Does Pine Roe Natural Gas have any facilities that require atmospheric corrosion inspections? (CORRAC101)

*Data Source:*

Conduct atmospheric corrosion inspection on meter sets during meter reading. All above ground piping is protected by paint.

Your Choice (weight: 0) --Yes

- Over the past 5 years, have any atmospheric corrosion inspections found metal loss due to atmospheric corrosion? (CORRAC103)

Your Choice (weight: 0) --No

- Over the past 5 years, have leaks caused by atmospheric corrosion required repair? (CORRAC104)

Your Choice (weight: 0) --No

- Have inspections found problems with above ground pipe coatings that could not be fixed by routine maintenance? (CORRAC105)

Your Choice (weight: 0) --No

- Confirm that no other atmospheric corrosion problems are known. (CORRAC204b)

Your Choice (weight: 0) --Accept

- **External Corrosion (CORRECPLAS) (Plastic With Isolated Metallic Fittings - Pine Roe Natural Gas is a low pressure distribution system with customer services regulators install at each service which requires no other over pressure protection.)**

- Interview Start (CORRECPLAS)

Your Choice (weight: 0) --Continue

- Are leaks on metallic fittings increasing? (EC102)

Your Choice (weight: 0) --

**Table 11.2. End of Year**

Leaks on Metallic Fittings	
In 2008	0
In 2009	0
In 2010	0
In 2011	0
In 2012	0

- SHRIMP has determined that leaks, failures or damages are not increasing.(see guidance).

Do you accept this determination? (EC252ok)

Your Choice (weight: 0) --Accept

- Your data and choices indicate that leaks on metallic fittings are not increasing. (EC252)

Your Choice (weight: 0) --Continue

- Do exposed pipe inspections indicate a corrosion problem? (EC202)

Your Choice (weight: 0) --No

- Confirm that no corrosion problems are known. (EC204a)

Your Choice (weight: 0) --Accept

**Equipment Malfunction Threat**

- **Equipment Malfunction (EQIP) (Pine Roe Natural Gas - Pine Roe Natural Gas is a low pressure distribution system with customer services regulators install at each service which requires no other over pressure protection.)**

- Interview Start (EQIP)

Your Choice (weight: 0) --Continue

- How many leak repairs resulting from equipment problems occurred during the years shown? (EQIP-Leak)

Your Choice (weight: 0) --

**Table 11.3. Leak Repairs From PHMSA 7100.1-1**

End of Year	Equipment Malfunction Totals			
	Mains	Services	Mains	Services
In 2008	0	0	0	0
In 2009	0	0	0	0
In 2010	0	0	0	0
In 2011	0	0	0	0
In 2012	0	0	0	0

- Are leaks occurring or do inspections indicate potential equipment malfunctions? (EQ101a)

Your Choice (weight: 0) --

None of These

- Does system contain equipment known/prone to malfunction (Industry wide)? (EQ102a)

*Data Source:*

Pine Roe Natural Gas has not had or reported any equipment failures.

Your Choice (weight: 0) --

None of These

- Confirm that no other equipment problems are known. (EQ204)

Your Choice (weight: 0) --Accept

## Incorrect Operations Threat

- **Incorrect Operations (IOP) (Pine Roe Natural Gas - Pine Roe Natural Gas is a low pressure distribution system with customer services regulators install at each service which requires no other over pressure protection.)**

- Interview Start (IOP)

Your Choice (weight: 0) --Continue

- How many leak repairs resulting from incorrect operations occurred during the years shown? (IOP-Leak)

Your Choice (weight: 0) --

**Table 11.4. Leak Repairs From PHMSA 7100.1-1**

End of Year	Incorrect Operations Totals			
	Mains	Services	Mains	Services
In 2008	0	0	0	0
In 2009	0	0	0	0
In 2010	0	0	0	0
In 2011	0	0	0	0
In 2012	0	0	0	0

- Have failures due to inadequate procedures been experienced during the past 5 years? (IOP101)

Your Choice (weight: 1) --Yes

- Have failures due to a failure to follow procedures been experienced? (IOP104)

Your Choice (weight: 0) --No

- Have any employees or contractors had operator qualification credentials revoked due to poor performance of any covered task? (IOP105)

Your Choice (weight: 0) --No

- Have employees or contractors tested positive for drugs or alcohol (other than pre-hire tests)? (IOP106)

Your Choice (weight: 0) --No

- Provide Additional Information (IOPSet2)

Your Choice (weight: 0) --

- **Inadequate Procedures (IOP-Proc) (Pine Roe Natural Gas - Pine Roe Natural Gas is a low pressure distribution system with customer services regulators install at each service which requires no other over pressure protection.)**

- Interview Start (IOP-Proc)

Your Choice (weight: 0) --Continue

- Is the number of failures due to inadequate procedures increasing? (IOP-Proc101)

Your Choice (weight: 0) --

**Table 11.5. End of Year**

	Failures
In 2008	0
In 2009	0
In 2010	0
In 2011	0
In 2012	0

- SHRIMP has determined that leaks, failures or damages are not increasing.(see guidance).

Do you accept this determination? (IOP-Proc102dok)

Your Choice (weight: 0) --Accept

- Your data and choices indicate that failures due to inadequate procedures are not increasing per year. (IOP-Proc102d)

Your Choice (weight: 0) --Continue

- Confirm that no other incorrect operations problems are known. (IOP-Proc204)

Your Choice (weight: 0) --Accept

**Material, Weld or Joint Failure Threat**

- **Material, Weld or Joint Failure (MW).(Pine Roe Natural Gas - Pine Roe Natural Gas is a low pressure distribution system with customer services regulators install at each service which requires no other over pressure protection.)**

- Interview Start (MW)

Your Choice (weight: 0) --Continue

- How many leak repairs resulting from material, weld or joint problems occurred during the years shown? (MW-Leak)

Your Choice (weight: 0) --

**Table 11.6. Leak Repairs From PHMSA 7100.1-1**

End of Year	Material, Weld or Joint Failure Totals			
	Mains	Services	Mains	Services
In 2008	0	0	0	0
In 2009	0	0	0	0
In 2010	0	0	0	0
In 2011	0	0	0	0
In 2012	0	0	0	0

- Have manufacturing defects on pipe or non-pipe components been experienced? (MW101)

Your Choice (weight: 0) --No

- Have failures due to workmanship defects been experienced? (MW102)

*Data Source:*

None to date.

Your Choice (weight: 0) --No

- Do any of the following materials exist on the system? (MW103)

Your Choice (weight: 0) --

I Don't Know

- Provide Additional Information (MWSet3)

*Data Source:*

Pine Roe continues to search its' materials records to determine if any of the products were installed. At this time we do not believe there have been.

Your Choice (weight: 0) --

## Excavation Damage Threat

- **Excavation Damage (OFEXC) (Pine Roe Natural Gas - Pine Roe Natural Gas is a low pressure distribution system with customer services regulators install at each service which requires no other over pressure protection.)**

- Interview Start (OFEXC)

Your Choice (weight: 0) --Continue

- Does your system participate in a qualified one-call system (see 192.614)? (OFEXC101)

*Data Source:*

Pine Roe Gas is a member of the Pennsylvania One Call System,

Your Choice (weight: 0) --Yes

- Which system do you do you use? (OFEXC102)

Your Choice (weight: 0) --Pennsylvania-Pennsylvania One Call System, Inc.

- Are you a Master Meter Operator? (OFEXC103)

Your Choice (weight: 0) --No

- Do you physically control access to your pipeline location? (OFEXC104)

*Data Source:*

However Pine Roe is continually patrolling its system.

Your Choice (weight: 0) --No

- How many excavation leak repairs occurred during the years shown? (OFEXC105)

*Data Source:*

PHMSA F 7100-1-1

Your Choice (weight: 0) --

**Table 11.7. Leak Repairs From PHMSA 7100.1-1**

End of Year	Excavation Damage Totals			
	Mains	Services	Mains	Services
In 2008	2	0	2	0
In 2009	2	0	2	0
In 2010	2	0	2	0
In 2011	0	0	0	0
In 2012	2	0	2	0

- How many excavation caused damages not resulting in leaks reported on the PHMSA 7100.1-1 form have occurred during the years shown? (OFEXC105a)

Your Choice (weight: 0) --

**Table 11.8. End of Year**

	Mains	Services
In 2008	0	0
In 2009	0	0
In 2010	0	0
In 2011	0	0
In 2012	0	0

- How many excavation tickets (receipt of information by the underground facility operator from the one-call system) were received during the years shown? (OFEXC106)

*Data Source:*

Records for excavation tickets are being researched at this time.

Your Choice (weight: 0) --

**Table 11.9. End of Year**

	Damages Previously Entered	Excavation Tickets	Damages Per 1000 Tickets
In 2008	2	0	0
In 2009	2	0	0
In 2010	2	0	0
In 2011	0	0	0
In 2012	2	0	0

- SHRIMP has determined that leaks, failures or damages are not increasing.(see guidance).

Do you accept this determination? (OFEXC106bok)

Your Choice (weight: 0) --Accept

- Your data and choices indicate that excavation damages per 1000 tickets are not increasing. (OFEXC106b)

Your Choice (weight: 0) --Continue

- Provide Additional Information (OFEXC106e)

Your Choice (weight: 0) --

- **Blasting Damage (OFEXC-Blast) (Pine Roe Natural Gas - Pine Roe Natural Gas is a low pressure distribution system with customer services regulators install at each service which requires no other over pressure protection.)**

- Interview Start (OFEXC-Blast)

Your Choice (weight: 0) --Continue

- Has damage occurred due to blasting? (OFEXC137)

*Data Source:*

No blasting has occurred in Pine Roe Natural Gas operational area.

Your Choice (weight: 0) --No

- Are there portions of the system located where excavation in the area of pipeline would require the use of explosives? (OFEXC135)

Your Choice (weight: 0) --No

- Are there portions of the system in known areas of blasting or demolition activity, such as rock quarries or coal mining? (OFEXC136)

Your Choice (weight: 0) --No

- Confirm that no other excavation problems are known. (OFEXC204)

Your Choice (weight: 0) --Accept

- **Concentrated Damages (OFEXC-Conc) (Pine Roe Natural Gas - Pine Roe Natural Gas is a low pressure distribution system with customer services regulators install at each service which requires no other over pressure protection.)**

- Interview Start (OFEXC-Conc)

Your Choice (weight: 0) --Continue

- You previously entered this information regarding excavation damages and tickets during the years shown.

Click Next to proceed. (OFEXC206)

*Data Source:*

Pine Roe Natural Gas Damage had been a result of outside forces. PineRoe Natural Gas is located in an area that is subject to the influence of natural forces.

Your Choice (weight: 0) --

**Table 11.10. End of Year**

	Damages Previously Entered	Excavation Tickets Previously Entered	Damages Per 1000 Tickets
In 2008	2	0	0
In 2009	2	0	0
In 2010	2	0	0
In 2011	0	0	0
In 2012	2	0	0

- Are these excavation damages concentrated in certain locations or distributed across the entire system? (OFEXC207)

Your Choice (weight: 0) --Distributed across the entire system

- Are these locate tickets concentrated in certain locations or distributed across the entire system? (OFEXC208)

Your Choice (weight: 0) --Distributed across the entire system

- Confirm that no other excavation problems are known. (OFEXC204)

Your Choice (weight: 0) --Accept

- **Crew or Contractor Damages (OFEXC-Crew) (Pine Roe Natural Gas - Pine Roe Natural Gas is a low pressure distribution system with customer services regulators install at each service which requires no other over pressure protection.)**

- Interview Start (OFEXC-Crew)

Your Choice (weight: 0) --Continue

- Has excavation damage been caused by your crews or your contractors? (OFEXC115)

Your Choice (weight: 0) --No

- Confirm that no other excavation problems are known. (OFEXC204)

Your Choice (weight: 0) --Accept

- **Third Party Damages (OFEXC-Third) (Pine Roe Natural Gas - Pine Roe Natural Gas is a low pressure distribution system with customer services regulators install at each service which requires no other over pressure protection.)**

- Interview Start (OFEXC-Third)

Your Choice (weight: 0) --Continue

- During the past few years, have excavation damages occurred due to third parties? (OFEXC127)

Your Choice (weight: 0) --No

- Confirm that no other excavation problems are known. (OFEXC204)

Your Choice (weight: 0) --Accept

## Natural Forces Threat

- **Natural Forces (OFNF) (Pine Roe Natural Gas - Pine Roe Natural Gas is a low pressure distribution system with customer services regulators install at each service which requires no other over pressure protection.)**

- Interview Start (OFNF)

*Data Source:*

PHMSA F 7100-1-1

Your Choice (weight: 0) --Continue

- Do leaks repaired per year average one (1) or more? (OFNF101rp)

*Data Source:*

PHMSA F 7100-1-1

Your Choice (weight: 0) --

**Table 11.11. Leak Repairs From PHMSA 7100.1-1**

End of Year	Natural Forces		Totals	
	Mains	Services	Mains	Services
In 2008	2	0	2	0
In 2009	2	0	2	0
In 2010	0	0	0	0
In 2011	2	0	2	0
In 2012	2	0	2	0

- How many natural forces damages not resulting in leaks reported on the PHMSA 7100.1-1 form have occurred during the years shown? (OFNF101nr)

Your Choice (weight: 0) --

**Table 11.12. End of Year**

	Mains	Services
In 2008	0	0
In 2009	0	0
In 2010	0	0
In 2011	0	0
In 2012	0	0

- Here is a summary of your natural forces damages during the years shown.

Click Next to Continue. (OFNF101)

Your Choice (weight: 0) --

**Table 11.13. End of Year**

	Leak Repairs	Damages Not	Total
		Reported	
In 2008	2	0	2
In 2009	2	0	2
In 2010	0	0	0
In 2011	2	0	2
In 2012	2	0	2

- SHRIMP has determined that leaks, failures or damages are averaging one (1) or more per year.(see guidance).

Do you accept this determination? (OFNF101aok)

Your Choice (weight: 0) --Accept

---

ATTACHMENTS

---

- Your data and choices indicate that leaks, failures or damages are averaging one (1) or more per year. (OFNF101a)

Your Choice (weight: 2) --Continue

- Are portions of the system/section in areas prone to land subsidence, earthquakes or washouts? (OFNF102)

Your Choice (weight: 0) --No

- Does the system/section contain Cast Iron pipe 8" or less in diameter? (OFNF301)

Your Choice (weight: 0) --No

- Have damages occurred on cast iron due to ground movement, frost heave, earth subsidence? (OFNF302)

Your Choice (weight: 0) --No

- Have natural forces caused leaks, failures or damages to steel or plastic pipeline in the system/section? (OFNF303)

*Data Source:*

PHMSA Form 7100 1-1

Your Choice (weight: 3) --Yes

- Are the natural force leaks, failures or damages system-wide or concentrated in local areas? (OFNF103)

Your Choice (weight: 0) --System-wide

- Review the guidance. (OFNFCSQ0)

Your Choice (weight: 0) --Continue

- Are the pressure and/or diameter of this section greater than or about the same as the system as a whole? (OFNFCSQ1)

Your Choice (weight: 0) --About the same

- Is this section predominantly located in business districts or outside business districts (as those are defined for leak survey)? (OFNFCSQ2)

Your Choice (weight: 0) --Outside Business Districts

- How long would it typically take utility crews to reach this part of the system after receiving notice of a possible failure? (OFNFCSQ3)

Your Choice (weight: 0) --Less than one (1) hour

- What would be the impact on the utility and its customers if this section were to fail? (OFNFCSQ4)

Your Choice (weight: 0) --Low

### Other Outside Forces Threat

- **Other Outside Forces (OFOTHR) (Pine Roe Natural Gas - Pine Roe Natural Gas is a low pressure distribution system with customer services regulators install at each service which requires no other over pressure protection.)**

- Interview Start (OFOTHR)

Your Choice (weight: 0) --Continue

- Do leaks repaired per year average one (1) or more? (OFOTHR101rp)

Your Choice (weight: 0) --

**Table 11.14. Leak Repairs From PHMSA 7100.1-1**

End of Year	Other Outside Forces Totals			
	Mains	Services	Mains	Services
In 2008	0	0	0	0
In 2009	0	0	0	0
In 2010	0	0	0	0
In 2011	0	0	0	0
In 2012	2	0	2	0

- How many other outside forces damages not resulting in leaks reported on the PHMSA 7100.1-1 form have occurred during the years shown? (OFOTHR101nr)

Your Choice (weight: 0) --

**Table 11.15. End of Year**

	Mains	Services
In 2008	0	0
In 2009	0	0
In 2010	0	0

Mains Services		
In 2011	0	0
In 2012	0	0

- Here is a summary of your other outside forces damages during the years shown.

Click Next to Continue. (OFOTHR101)

Your Choice (weight: 0) --

**Table 11.16. End of Year**

	Leak Repairs	Damages Not Reported	Total
In 2008	0	0	0
In 2009	0	0	0
In 2010	0	0	0
In 2011	0	0	0
In 2012	2	0	2

- SHRIMP has determined that leaks, failures or damages are not averaging one (1) or more per year.(see guidance).

Do you accept this determination? (OFOTHR101bok)

Your Choice (weight: 0) --Accept

- Your data and choices indicate that leaks, failures or damages are not averaging one (1) or more per year. (OFOTHR101b)

Your Choice (weight: 0) --Continue

- Confirm that no other outside force problems are known. (OFOTHR204)

Your Choice (weight: 0) --Accept

## Other Threats Threat

- **Other Threats (OTHR) (Pine Roe Natural Gas - Pine Roe Natural Gas is a low pressure distribution system with customer services regulators install at each service which requires no other over pressure protection.)**

- Interview Start (OTHR)

Your Choice (weight: 0) --Continue

- Has this system experienced failures or other safety problems due to causes that were not addressed during the evaluation of the other threats? (OTHR101)

Your Choice (weight: 0) --Yes

- Enter, on a separate line below, a name for each Other Threat that you are experiencing and a brief description of the problem. (OTHR102a)

Your Choice (weight: 0) --

**Table 11.17. Section**

Description
Other_00
Other_01
Other_02
Other_03
Other_04

- You have indicated that there are no other issues to be considered. (OTHR204)

Your Choice (weight: 0) --Continue

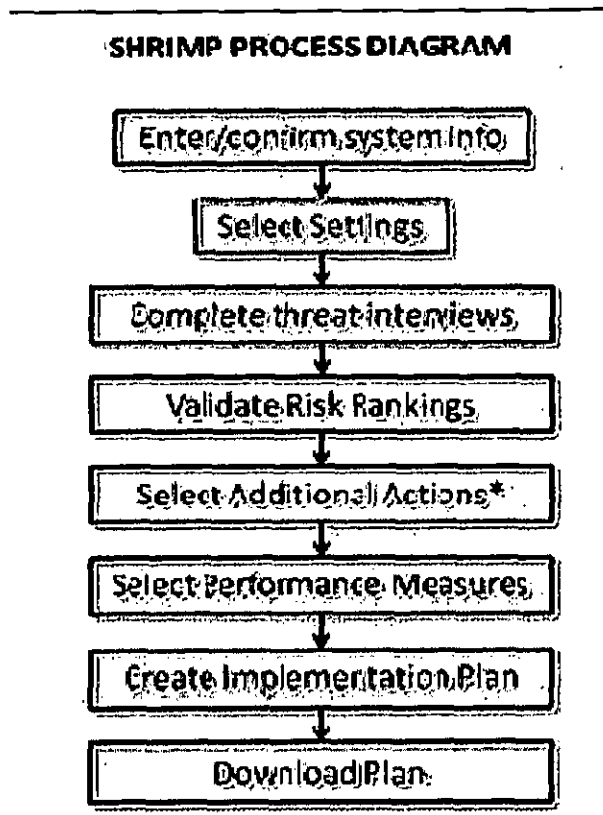
## 11.3. DESCRIPTION OF THE PROCESS FOLLOWED TO DEVELOP THIS PLAN

### 11.3.1. Process Description

#### Procedures for developing and implementing DIMP elements using SHRIMP

Creating a written DIMP Plan using SHRIMP should follow the steps shown in the SHRIMP process diagram. Each step should be completed before moving on to the next step.

Figure 11.1. SHRIMP Process Diagram



#### 1. Enter/confirm system information

If your system filed a Distribution Annual Report (Form 7100.1-1) you should find your system data already entered into SHRIMP. Note, this may not be the most current data – at the time SHRIMP was created only the annual reports for 2009 were available. This information is shown only to allow you to confirm that this is your system – it is not used for any other purpose in SHRIMP.

If your annual report data is not already entered in SHRIMP, e.g. you are a master meter or LP piping system operator that is not required to file annual reports, or your annual report is missing from PHMSA's database, you must enter the data manually.

#### 2. Select settings

The next step is to enter settings for your plan. These include:

- The name of your system as you want it to appear in the plan,
- A description of what part of your system this plan covers (default is entire system),
- The effective date of the plan (for your first plan this should be no later than August 2, 2011 as required by the DIMP rule),
- The effective date of the DIMP Plan replaced by this Plan – SHRIMP automatically generates this,
- The History Period – this is how many years back you will enter inspection and maintenance data such as leak repairs, line locate tickets, etc. in the threat interviews. The default and minimum is 5 years and but you can change this to up to 10 years if you have the data. More years data = better DIMP plans.

- A LEAK management policy – Either select one of the two pre-written options in SHRIMP or if you already have a leak management plan that meets the rule's requirements enter a cross reference to that policy, and
- A program re-evaluation period, anywhere from 1 to 5 years.

You can go back and change these at any time by clicking on the Required Settings link in the menu bar on the left side of SHRIMP screens

### 3. Complete threat interviews

SHRIMP uses an interview process to assess each of the eight threats required by the DIMP rule. The 8 threats are:

1. Corrosion
2. Equipment Malfunction
3. Incorrect Operations
4. Material, Weld or Joint Failure
5. Excavation Damage
6. Natural forces
7. Other outside forces
8. Other Threats

Some of the threats are broken down into two or more subthreats. You must complete each threat and subthreat interview before going to Steps 4 and beyond. You can go back and change any of the information you provide in the threat interviews by clicking on the System Overview link on the menu then clicking on the blue "Review" link next to the threat interview in which you wish to make changes. Select the blue question number link by the question and the interview form will open. Make changes, but you may have to re-complete all of the interview questions after that question if your change affects answers to later questions. This is described in more detail later in this users guide.

### Note

You can complete the first seven threat interviews in any order, however you MUST complete the first seven interviews before attempting to complete the "Other Threats" interview. The answers you provide in the Other Threats interview depend on the answers you provided in the other 7 threat interviews.

The threat interviews are intended to satisfy the following two requirements of the DIMP rule: Section 192.1007 (a) Knowledge and (b) Identify Threats. These requirements and the procedure followed by SHRIMP are further described in an attachment to this document.

### 4. Validate Risk Rankings

After all 8 threat interviews have been completed SHRIMP will rank each threat and section by relative risk, from highest to lowest, based on a numerical model that considers the likelihood and consequences were a segment of your system to fail due to the threat. A complete description of this risk ranking model is found in an appendix to this user's guide and an attachment to your written DIMP Plan created by SHRIMP.

Click on Risk Ranking in the left menu to open the risk ranking screen. If you entered any threats in the "Other Threats" interview those threats will be listed first with no assigned rank. These threats MUST be

manually placed by the user where the user feels these threats belong in the list of threats. The process for that is described in further detail in the risk ranking section of the user's guide. You should not automatically accept SHRIMP's order of risk ranking. Review it, consider the summary description of why SHRIMP ranked each threat and, if you disagree with the order, rearrange the order of threats as you believe it should be, and be sure to enter a description of what factors you considered that led you to change the order. **This is a very important step!**

The risk ranking validation process is intended to satisfy the following requirement of the DIMP rule: Section 192.1007 (c) Evaluate and rank risk.

5. **Select Additional Actions\***

After you are satisfied that all threat-sections are ranked in the correct order, the next step is to select additional actions you will undertake to reduce those threats. Additional actions means actions above and beyond what is required by pipeline safety regulations. Other than implementing a leak management program, the DIMP rule does not presume that any further additional actions are necessary. You must decide whether any of the threats pose a level of risk that warrants additional action. SHRIMP cannot make that determination. There is additional guidance on selecting additional actions in the additional actions section of this user's guide.

SHRIMP offers at least one additional action for each threat. Click on the blue Choose AAs link in the Risk Ranking screen to display a list of possible additional actions for that threat. If you decide additional actions are warranted you can select one or more of SHRIMP's additional actions or you can create your own by clicking on the Manage AAs link in the left-side menu in SHRIMP.

This step is intended to satisfy the following requirement of the DIMP rule: Section 192.1007 (d) Identify and implement measures to address risks.

6. **Select Performance Measures**

The next step is to select performance measures for each of the additional actions you selected in Step 5. If you didn't feel any threats warranted additional actions you can skip this step.

The process of selecting performance measures is identical to selecting additional actions in the prior step. Click on the Choose PMs link then select one or more of the displayed, threat-specific performance measures. You can create your own performance measures by clicking on Manage PMs in the left-side menu.

This step is intended to satisfy the following requirement of the DIMP rule: Section 192.1007 (e) Measure performance, monitor results and evaluate effectiveness.

7. **Create Implementation Plan**

Now you are ready to review the actions required to implement your written DIMP plan. All of the actions required by the rule or selected by you in the additional actions and performance measures steps can be displayed by clicking on "Implementation Plan" in the left-side menu. The Implementation Plan should answer the questions of Who, What, When, Where and How each required action will be accomplished. Action items in your written DIMP Plan can be summarized in the following areas:

1. Describing how you will modify your procedures, policies and recordkeeping system(s) as necessary to collect and retain information required to be collected and retained under the DIMP plan, including mandatory performance measures and performance measures you selected in the previous step, and
2. Describing how you will implement any Additional/Accelerated Actions that you included in your written DIMP plan.

Each action item will be listed separately with a text box in which you must enter a description of how you will accomplish this action.

## 8. Download your written DIMP Plan

When you are satisfied that Steps 1-7 are complete you should download your written DIMP plan to your computer. Click on Written Plan in the left-side menu and a list of download options will be displayed.

Review the Required Settings one more time to ensure your system name appears as you want it to appear in your Plan and that the other information is correct.

Click on Web Page Format to display the written plan on your web browser. You can do this at any time during the process of creating your plan to see how selections you have made up to that point affect what is written into your plan. It is recommended that you look at the Plan in the Web Page Format frequently as you work on Steps 1-7 to see how data you enter appears in your Plan – it may affect how you write some text that will go into your Plan.

You may save your plan to your computer as a Web Page using the Save command on your web browser.

Click on Microsoft WORD Document to download your plan as a WORD file that you can edit using Microsoft WORD or other word processing software. (Note that the translator that creates this file may lose some formatting of the Table of Contents and other portions of the Plan. We apologize for any inconvenience this may cause you. We are evaluating other options for creating WORD files.)

Click on Adobe PDF Format to download your written Plan as an Adobe PDF file.

## SHRIMP Procedures Compared To DIMP Rule Requirements

This section describes the procedures to be followed to develop and implement the 7 required elements of the *Distribution Integrity Management Programs (DIMP) written Plan*. For each required element the text of the DIMP rule is provided, followed by a description of the procedure to develop and implement that element.

### a. Knowledge

**The Rule:** An operator must demonstrate an understanding of its gas distribution system developed from reasonably available information.

1. Identify the characteristics of the pipeline's design and operations and the environmental factors that are necessary to assess the applicable threats and risks to its gas distribution pipeline.
2. Consider the information gained from past design, operations, and maintenance.
3. Identify additional information needed and provide a plan for gaining that information over time through normal activities conducted on the pipeline (for example, design, construction, operations or maintenance activities).
4. Develop and implement a process by which the IM program will be reviewed periodically and refined and improved as needed.
5. Provide for the capture and retention of data on any new pipeline installed. The data must include, at a minimum, the location where the new pipeline is installed and the material of which it is constructed.

**The Procedure:** (Numbers in parenthesis refer to the requirements shown above)

(1 & 2) During the 8 threat assessments SHRIMP asks questions about the user's system design, operations and environmental factors necessary to assess the applicable threats and risks to distribution pipeline integrity. The user should refer to current and past design, construction, operation, inspection and maintenance records, as well as the knowledge of utility personnel to accurately answer questions posed by SHRIMP. SHRIMP includes a Data Source field with each question for the user to record the source of information used to answer each question. Information entered into this field will be included in an attachment to the written DIMP plan along with a complete list of questions answered during the SHRIMP process. Where past data is requested by

SHRIMP, a minimum of the previous 5 years' data is requested, however if more than 5 years' data is readily available the user is encouraged to use that data as well.

In addition, during the Risk Ranking Validation step, the user should consider any additional factors that may affect the probability and/or consequences of a failure of a particular section of distribution piping but that were not asked about by SHRIMP. Examples could include pipe located near hospitals, schools, nursing homes or other difficult to evacuate facilities; environmental factors such as soil corrosivity; and more. During the Risk Ranking Validation step, any additional knowledge considered by the user to change the relative risk ranking of any section should be described in the text box provided by SHRIMP. This description will be written into the written DIMP Plan in the Risk Ranking section.

(3) If any of the design, construction or environmental factors requested by SHRIMP are not readily available the user should answer "I don't know." SHRIMP will then offer pre-written text describing how the user will gain that information over time through normal activities conducted on the pipeline. The user can accept SHRIMP's plan or enter their own description of how that knowledge will be gained. The SHRIMP text or the user's text will be included in the written DIMP plan.

(4) A process by which the IM program will be reviewed periodically and refined and improved as needed using SHRIMP is under development. This procedure will require the user to revisit each question answered in SHRIMP and either confirm the answer provided is still accurate or update the information. SHRIMP will generate a log of differences between the old plan to the new plan. SHRIMP will save a copy of the old plan for 10 years. The user is also encouraged to download the new and old plans for their records.

(5) SHRIMP includes an attachment that is the implementation plan. This attachment summarizes all the actions required to follow the DIMP plan, including capture and retention of data on any new pipeline installed. Since each user may have a unique recordkeeping system SHRIMP cannot advise the best way to track this data and instead provides a text box for the user to describe how these records will be captured and retained.

b. Identify threats

**The Rule:** The operator must consider the following categories of threats to each gas distribution pipeline: Corrosion, natural forces, excavation damage, other outside force damage, material, weld or joint failure (including compression coupling), equipment failure, incorrect operation, and other concerns that could threaten the integrity of its pipeline. An operator must consider reasonably available information to identify existing and potential threats. Sources of data may include, but are not limited to, incident and leak history, corrosion control records, continuing surveillance records, patrolling records, maintenance history, and excavation damage experience.

**The Procedure:** SHRIMP uses an interview process to identify threats. The user must go through interviews for each of the eight threats listed above. In many cases there are two or more subthreat interviews within each threat interview. For example, the corrosion threat interview includes separate interviews for external, internal and atmospheric corrosion, and the external corrosion interview includes further separate interviews for different materials of construction (bare/coated, protected/unprotected steel, cast/wrought iron, etc.). These interviews ask for reasonably available information to identify existing and potential threats. All of the sources of data listed in the rule are directly asked for by SHRIMP except for continuing surveillance – continuing surveillance is the periodic review of other inspection and maintenance data to determine the continued serviceability of the pipe. If prior continuing surveillance reviews resulted in additional inspections or maintenance, the results of those actions should be entered into SHRIMP where SHRIMP asks for the results of such inspection and maintenance, therefore indirectly SHRIMP considers continuing surveillance records.

c. Evaluate and rank risk

**The Rule:** An operator must evaluate the risks associated with its distribution pipeline. In this evaluation, the operator must determine the relative importance of each threat and estimate and rank the risks posed to its pipeline. This evaluation must consider each applicable current and potential threat, the likelihood of failure associated with each threat, and the potential consequences of such a failure. An operator may subdivide its pipeline into regions with similar characteristics (e.g., contiguous areas within a distribution pipeline

consisting of mains, services and other appurtenances; areas with common materials or environmental factors), and for which similar actions likely would be effective in reducing risk.

**The Procedure:** The SHRIMP Advisory Group developed a risk ranking model that assigns a numeric weighting to answers provided by the user. The risk ranking model is described in an attachment to this document.

Subdividing is not required by SHRIMP but encouraged where answers to SHRIMP threat assessment questions are different for different parts of the system. Many of the questions asked by SHRIMP during the threat assessment process are intended to assess the likelihood and consequences of a failure due to the threat being assessed. SHRIMP also asks questions to help determine if certain regions of the pipeline have similar characteristics and for which similar actions would be effective in reducing risk. If actual or potential threats identified during the threat assessment process are concentrated in certain areas, the user is encouraged to subdivide the system for that threat, separating the areas that have an actual or potential threat from those areas that don't. Subsections can be geographic, by material, by type of equipment (for equipment threat), by excavator crews or contractors (for excavation threat) or any other way of subdividing that makes sense for the user's situation.

If the user decides to subsection for any threat those subsections continue through the risk-ranking, implementing additional measures and performance measures steps. The system may be subdivided differently for each threat, since it is unlikely that an area at risk for one threat (e.g. external corrosion) would also be entirely at risk from another threat (e.g. natural forces).

d. Identify and implement measures to address risks

**The Rule:** Determine and implement measures designed to reduce the risks from failure of its gas distribution pipeline. These measures must include an effective leak management program (unless all leaks are repaired when found).

**The Procedure:** SHRIMP offers the user at least one option to reduce the risk from failure for each threat except "Other." In the risk ranking screen, clicking on "A/A's" brings up a list of potential additional/accelerated actions ("A/A Actions") that the SHRIMP Advisors have determined could be effective in addressing the actual or potential threat. Some A/A Actions may be listed first because answers provided by the user during the threat assessment process suggests these A/A Actions are likely to be effective, whereas other A/A Actions that aren't expected to be effective are listed separately.

The user can select one or more of the A/A Actions included in SHRIMP, which will result in pre-written text being inserted into the "Implement Measures" section of written DIMP plan for the particular subsection of the system and threat. If the user has a better idea, or has already implemented action addressing this threat, the user should create a user-defined A/A Action and select that A/A Action for this threat and subsection. What the user writes when defining the A/A Action will be written into the written DIMP plan.

For some threats SHRIMP will recommend that the user initiate some A/A Action to reduce risk. For most threats the SHRIMP advisors could not agree on any relative risk score or combination of threat interview answers that should automatically require the user to specify an A/A Action. It is therefore up to the user to use his/her best judgment as to which threat-segments merit additional actions to reduce risk. The DIMP rule does not presume that every operator needs to implement additional measures.

If a user elects to include additional measures to reduce risk for any of the threats and/or subdivisions of the distribution system, SHRIMP will offer one or more options for performance measures specific to that threat and subdivision. The user may select pre-written text offered by SHRIMP or substitute a user-defined performance measure. The user is required to select at least one threat and subdivision-specific performance measure for every additional action selected in the previous step.

At the end of the SHRIMP process, SHRIMP displays a list of action items, including mandatory performance measures [(i) through (v) in the next section] and any threat-specific additional measures the operator determines are needed to evaluate the effectiveness of the operator's IM program in controlling each identified

threat. The user is asked to describe in a text box how each action will be implemented and that information is included in the Implementation Plan included as an attachment to the written DIMP plan.

e. Measure performance, monitor results and evaluate effectiveness

**The Rule:** Develop and monitor performance measures from an established baseline to evaluate the effectiveness of its IM program. An operator must consider the results of its performance monitoring in periodically re-evaluating the threats and risks. These performance measures must include the following:

- i. Number of hazardous leaks either eliminated or repaired as required by Sec. 192.703(c) of this subchapter (or total number of leaks if all leaks are repaired when found), categorized by cause;
- ii. Number of excavation damages;
- iii. Number of excavation tickets (receipt of information by the underground facility operator from the notification center);
- iv. Total number of leaks either eliminated or repaired, categorized by cause;
- v. Number of hazardous leaks either eliminated or repaired as required by Sec. 192.703(c) (or total number of leaks if all leaks are repaired when found), categorized by material; and
- vi. Any additional measures the operator determines are needed to evaluate the effectiveness of the operator's IM program in controlling each identified threat.

**The Procedure:** The written plan created using SHRIMP includes a section stating that the operator will keep records necessary to report performance measures (i) through (v). These performance measures must be captured and recorded outside of SHRIMP – SHRIMP does not currently include a recordkeeping or performance measure tracking mechanism, although those enhancements are contemplated in future upgrades.

Where a performance measure requires data that has not previously been collected and retained by the operator, the baseline for such performance measures will be the first year such data is collected and retained. Where the operator does have past data for any performance measure, the user must establish a baseline based on that historical data. The baseline should be included in the implementation plan text for that performance measure.

At the end of the SHRIMP process, SHRIMP displays a list of action items, including mandatory performance measures (i) through (v) above and any threat-specific additional measures the operator determines are needed to evaluate the effectiveness of the operator's IM program in controlling each identified threat. The user is asked to describe in a text box how each action will be implemented and that information is included in the Implementation Plan included as an attachment to the written DIMP plan.

f. Periodic Evaluation and Improvement

**The Rule:** An operator must re-evaluate threats and risks on its entire pipeline and consider the relevance of threats in one location to other areas. Each operator must determine the appropriate period for conducting complete program evaluations based on the complexity of its system and changes in factors affecting the risk of failure. An operator must conduct a complete program re-evaluation at least every five years. The operator must consider the results of the performance monitoring in these evaluations.

**The Procedure:** The SIF is currently working on a procedure to use SHRIMP to automate the re-evaluation process. SHRIMP includes in the written plan a requirement for periodic complete program re-evaluations at least once every 5 years and more often if certain conditions are met. The user should consider additional events that might trigger a complete program re-evaluation.

A re-evaluation using SHRIMP is essentially revisiting each SHRIMP interview screen to verify the answer is still valid or updating information as necessary. The risk ranking screen must be reviewed to ensure it is still accurate. The user must review each of the 5 mandatory performance measures described above and any threat-specific performance measures included in the written plan and compare results to the baseline [Note: Where a performance measure requires data that has not previously been collected and retained by the

operator, the baseline for such performance measures will be the first year such data is collected and retained.] Particular attention should be given to the threat-specific performance measures that measure the effectiveness of specific A/A Actions. If one or more of these performance measures indicates that the A/A Action is not effective, the user should consider modifying the A/A Action and/or implementing additional A/A Actions.

g. Report results

**The Rule:** Report, on an annual basis, the four measures listed in paragraphs (e)(1)(i) through (e)(1)(iv) of this section, as part of the annual report required by Sec. 191.11. An operator also must report the four measures to the state pipeline safety authority if a state exercises jurisdiction over the operator's pipeline.

**The Procedure:** The SHRIMP written DIMP Plan includes a Section on reporting results, listing procedures for reporting to both the federal and state pipeline safety agencies. Currently data to report these performance measures must be collected and retained outside of SHRIMP, however the APGA Security and Integrity Foundation (SIF) may modify SHRIMP to enable it to retain and submit these performance measures as well as mechanical fitting failure data and other data required by Distribution Annual Report Form 7100.1-1.

### 11.3.2. Relative Risk Model

The centerpiece of the Simple, Handy, Risk-based Integrity Management Plan (SHRIMP) is the risk ranking model. SHRIMP uses an index model in which numeric scores are assigned based on answers provided by the user to questions asked by SHRIMP. The index model was developed by the APGA Security and Integrity Foundation (SIF) with guidance by an advisory group comprised of industry and federal and state pipeline safety regulators.

Risk is the product of the probability of a failure times the consequences of a failure. The SHRIMP relative risk model considers both the probability and consequences of a failure for each of the eight threats. The equation is as follows:

**Table 11.18.**

Relative Risk Score	=	Probability (Normalized to 10)	x	Consequence Score (1.0 - 1.5)	x	Leak Factor (1 + % of Lks)	x	Incident Probability Factor (1.0 or 1.25)
---------------------	---	--------------------------------	---	-------------------------------	---	----------------------------	---	---

Each of the four components that go into the relative risk score are described in the following sections.

**Probability Score** is the sum of points assigned by answers to threat interview questions. Each segment receives a relative probability score for each threat based on the answers to a series of questions. The probability questions are based on the GPTC DIMP guidance, as modified and added to by the SIF SHRIMP Advisors. The weighting given to each possible answer are based on the knowledge and experience of the SHRIMP Development Team and the SHRIMP Advisors.

**Table 11.19. Probability Scores**

Threat	Subthreat category	Maximum Score	Minimum Score	Incident Probability Factor
Natural Forces	No subthreats	19	0	1
Other Outside Forces	No subthreats	12	0	1.0
Excavation Damage	Grouping by 39 concentration of damages or tickets	39	0	1.25
	Grouping by operator crew or operator contractor damage	34	0	1.25

ATTACHMENTS

Threat	Subthreat category	Maximum Score	Minimum Score	Incident Probability Factor
Corrosion	Grouping by Third Party Damage	31	0	1.25
	Blasting	15	0	1.25
	External Corrosion	16	1	1
	Internal Corrosion	30	1	1
	Atmospheric Corrosion	25	1	1
Incorrect Operations	Failure to Follow Procedures	5	1	1.25
	Inadequate Procedures	5	1	1.25
	Operator Qualification	5	1	1.25
	Drug & Alcohol	5	1	1.25
Equipment	No subthreats	5	1	1
Material, Welds or Joints	No subthreats	5	1	1
Other	No subthreats	None (User assigns rank)		1

Because there are different numbers of questions for each threat and subthreat, the maximum possible score for each threat and subthreat are different, therefore the probability score for each threat-segment is normalized to a scale of 1 - 10 using this equation:

Normalized probability score =  $1 + (9 \times (\text{subthreat score} - \text{subthreat minimum score}) / (\text{subthreat maximum score} - \text{subthreat minimum score}))$

For example, if a segment received a score of 9 for external corrosion the normalized probability score would be  $1 + (9 \times (9-1) / (16-1)) = 1 + 9 \times 8/15 = 5.8$

**Incident Probability Factor**

The normalized probability factor described above is useful to rank various sections by the probability of a failure occurring within each of the eight threats, but SHRIMP also must rank sections across the eight threats. Failures due to some threats are more likely to cause death, injury or significant property loss than other threats. DOT Distribution Annual and Incident Report data shown below provide an indication of how likely it is that a failure (e.g. leak) due to one of the 8 threats will result in death, injury or significant property loss.

**Table 11.20. Incident Probability Factor**

Reported Incidents and Failures 2005-2007	Cause of # of Incidents	# of Failures	Incidents/1000 Failures	Normalized to Corrosion
Corrosion	6	293,933	0.02	1
Excavation Damage	73	338,666	0.22	11
Incorrect Operations	8	30,145	0.27	13
Material, Weld or Joint Failure	8	147,384	0.05	3
Equipment Failure	6	140,442	0.04	2
Natural Force Damage	22	77,229	0.28	14

Reported Incidents	Cause and Failures	# of Incidents	# of Failures	Incidents/1000 Failures	Normalized to Corrosion
2005-2007					
Other Damage	Outside Force	39	37,426	1.04	51
All Other Causes *		NA	NA	NA	

\* Excluding Fire First Incidents

The results of this analysis find that failures due to three threats (corrosion, material failure and equipment failure) are least likely to result in reportable incidents, that failures due to excavation damage, incorrect operations and natural force damage are moderately likely to result in reportable incidents and that other outside force damage failures are most likely to result in reportable incidents.

The advisors agreed to assign an Incident Probability Factor of 1.0 (no increase in relative risk score) for Corrosion, Materials/Welds, Equipment, and Other Outside Force Threats where it is relatively unlikely a failure will result in a reportable incident. For Excavation, Incorrect Operations, and Natural Force Threats where it is relatively more likely that a failure will result in a reportable incident the advisors agreed on an Incident Probability Factor of 1.25 (e.g. a 25% increase in relative risk score for these threats).

Further investigation of the "other outside force" category revealed that virtually all the incidents involved vehicles striking above ground facilities, usually meter sets. The SHRIMP advisors agreed with the PHMSA Phase I report conclusions that there was not enough information to conclude that vehicular damage could have been anticipated at the location of these incidents or whether meter protection existed, therefore no additional weighting is provided for this threat. SHRIMP does, however, include assessment of vehicle damage in the threat assessment and offer additional/accelerated actions if vehicular damage is found to be a significant threat.

If the user sections the system by geographic area, the Consequence Score is determined by points assigned based answers to threat interview questions as follows:

**Table 11.21. Consequence Score (Geographic Area Sections)**

Question	Possible Answers	Weighting
CSQ-1 Are the pressure and/or diameter of this section greater than or about the same as the system as a whole?	Substantially greater	0.2
	Somewhat greater	0.1
	About the same	0
CSQ-2 Is this section predominantly located in business districts or outside business districts (as those are defined for leak survey)?	Within Business Districts	0.15
	Outside Business Districts	0
CSQ-3 How long would it typically take utility crews to reach this part of the system after receiving notice of a possible failure?	Less than one (1) hour	0
	Between one (1) and two (2) hours	0.025
	More than two (2) hours	0.05
CSQ-4 What would be the impact on the utility and its customers if this section were to fail?	Low	0

ATTACHMENTS

Question	Possible Answers	Weighting
	Moderate	0.05
	High	0.1

The base consequence factor is 1.0

1. Greater pressure and/or diameter can increase the consequence factor by up to 20% (1.0 to 1.2)
2. Sections predominantly within business districts get an additional 15% increase in the consequence factor
3. The time to respond to a failure results in an increase in consequence factor of up to 5% (1.0 to 1.05)
4. The significance of the facility can result in an increase in consequence factor of up to 10% (1.0 to 1.1)

These weightings are based on the knowledge of the subject matter experts on the SHRIMP Advisory Group. These increases are added together to calculate the consequence factor for the section. If all four questions were answered so that maximum scores were assigned, the consequences factor would be 1.50 (1.2 + 1.15 + 1.05 + 1.1). The overall relative risk score would be increased by 50%.

If all four questions are answered so the minimum scores are assigned, then the consequence factor will be 1.0 and the relative risk score would be unchanged by this factor.

If the user does not create subsections for a threat, then these consequence questions are not asked.

For the threats shown below where the geography based threat questions do not apply the following threat specific consequence questions are asked:

**Table 11.22. Consequence Score (Non-Geographic Area Sections)**

	Question	Possible Answers	Weighting
CSQ-EXC1	Have the (crews/contractors/excavators) identified for this section caused damage that resulted in a reportable incident?	Yes	0.3
		No	0
CSQ-EXC2	Considering disruption of service and cost to return the system to service, how serious are the damages caused by the (crews/contractors/excavators) identified for this section when compared to all other excavation caused damages?	More serious	0.3
		Less serious	0
		About the same	0.1
CSQ-GEN1	What would be the potential consequences (injuries and/or property loss) if a failure were to occur because of this problem?	High likelihood of serious injury and/or property loss	0.5
		Moderate likelihood of injury and/or property loss.	0.25
		Not likely to result in injury and/or property loss.	0
EQIPCSQ-1	Is the size/capacity of the equipment substantially greater or lesser than other equipment in the system as a whole?	Substantially greater	0.2
		Somewhat greater	0.1

Question	Possible Answers	Weighting
EQIPCSQ-2 Does the equipment primarily affect the system located in the business district?	About the same	0
	Within Business Districts	0.15
EQIPCSQ-3 How long would it typically take utility crews to reach this part of the system after receiving notice of a possible failure?	Outside Business Districts	0
	Less than one (1) hour	0
	Between one (1) and two (2) hours	0.025
EQIPCSQ-4 What would be the impact on the utility and its customers if this equipment were to fail?	More than two (2) hours	0.05
	Low	0
	Moderate	0.05
	High	0.1

**Leak Cause Factor**

While most leaks are repaired without incident, the SHRIMP advisors felt that the users integrity management plan should consider the relative percentage of leaks by cause.

The Leak Cause Factor equals 1 + the percentage of leaks associated with threat to the total number of leaks for the system.

If the number of total leaks over a five year period are less than 50, the national average is used rather than the users leak history data because with fewer than 50 leak repairs the relative percentages of leaks by cause may be skewed by a handful of leak repairs that are not representative of the system. The national average is shown below, taken from leak repair data reported to PHMSA by all distribution operators on Annual Report Form 7100.1-1..

**Table 11.23. Reported Cause Of Failures (2005-2009)**

Threat	Failures	Percent	Leak History Factor
Corrosion	399,378	26	1.26
Excavation Damage	161,079	11	1.11
Incorrect Operations	38,416	3	1.03
Material, Weld or Joint Failure	155,255	10	1.10
Equipment Malfunction	326,793	21	1.21
Natural Force Damage	82,565	5	1.05
Other Outside Force Damage	40,529	3	1.03
All Other Causes	329,401	21	NA *
Totals	1,533,416	100	

\* Since the threat category "Other" is not assigned a relative risk score by SHRIMP the leak history factor is not used for that threat.

---

# Chapter 12. REFORMAT TEMPLATE

## Heading 1

This chapter is used by the word reformatting macros.

### REFORMAT TEMPLATE Sub Heading 1

#### 12.1. REFORMAT TEMPLATE Heading 2

##### REFORMAT TEMPLATE Sub Heading 2

###### 12.1.1. REFORMAT TEMPLATE Heading 3

##### REFORMAT TEMPLATE Sub Heading 3

##### REFORMAT TEMPLATE Heading 4

##### REFORMAT TEMPLATE Sub Heading 4

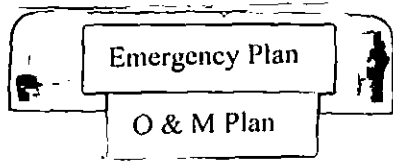
##### REFORMAT TEMPLATE Heading 5

##### REFORMAT TEMPLATE Sub Heading 5

RECEIVED

MAR - 4 2014

PA PUBLIC UTILITY COMMISSION  
SECRETARY'S BUREAU



RECEIVED

MAR - 4 2014

PA PUBLIC UTILITY COMMISSION  
SECRETARY'S BUREAU

**Pine Roe Natural Gas Company  
Operation, Maintenance, Emergency  
Response and Operator Qualification  
Plan**

---

## SCOPE

These procedures are in accordance with the applicable rules and regulations of the Pennsylvania Public Utility Commission and Code of Federal Regulations 49 Part 192. Pine Roe Natural Gas Company is a small gas distribution company with its office located at 151 Hotel Drive, Clarion, Pennsylvania.. It operates 17 miles of plastic distribution main at 5 psig with an MAOP of 25 psig. Pine Roe Natural Gas Company operates under 60psig serving 170 customers with service regulators installed and set at 8 inches w.c., so no other overpressure protection is required.

## OBJECTIVE

The purpose of this document is to outline the procedures for operations, maintenance and emergency response, necessary for the safe operation of Pine Roe Natural Gas distribution system and procedures for response to pipeline emergencies. Communication and liaison with public officials, police and fire departments are necessary elements of this program. Pine Roe communicates with it local police and fire department on a regular basis.

Pine Roe Natural Gas has a commitment to public safety by making every effort for protecting people first and then property.

## REVIEW AND UPDATING

Pine Roe Natural Gas reviews its Procedure manual for operations, maintenance and emergencies annually but not to exceed 15 months.

## DEFINITIONS

*Abandoned* means permanently removed from service.

*Customer meter* means the meter that measures the transfer of gas from and operator to a customer.

*Distribution line* means a pipeline other than a gathering or transmission line.

*Gas* means natural gas, flammable gas, or gas that is toxic or corrosive.

*Gathering line* means a pipeline that transports gas from a current production facility to a transmission line or main.

*Incident* means any of the following events.

- (1) An event that involves a release of gas from a pipeline of liquefied natural gas or gas from an LNG facility and
  - (i) A death, or personal injury necessitating in-patient hospitalization; or
  - (ii) Estimated property damage including cost of gas lost, of the operator or others, or both, of \$50,000 or more.
- (2) An event that results in an emergency shutdown of an LNG facility.
- (3) An event that is significant, in the judgment of the operator, even though it did not meet the criteria of paragraphs (1) or (2).

*Main* means a distribution line that serves as a common source of supply for more than one service line.

*Maximum actual operating pressure* means the maximum pressure that occurs during normal operations over a period of one year.

*Maximum allowable operating pressure (MAOP)* means the maximum pressure at which a pipeline or segment of a pipeline may be operated under Part 192.

*Operator* means a person who engages in the transportation of gas.

*Pipe* means any pipe or tubing used in the transportation of gas.

*Pipeline facility* means new and existing pipelines, right-of-way, and any equipment, facility, or building used in the treatment of gas during the course of transportation.

*Service line* means a distribution line that transports gas from a common source of supply to an individual customer, to two adjacent or adjoining residential or small commercial customers, or to multiple residential or small commercial customers served through a meter header or manifold. A service line ends at the outlet of the customer meter or at the connection to a customer's piping, whichever is further downstream, or at the connection to customer piping if there is no meter.

*Service regulator* means the device on a service line that controls the pressure of gas delivered from a higher pressure to the pressure provided to the customer. A

service regulator may serve one customer of multiple customers through a meter header or manifold.

### **Subpart A & E**

**Section 192.11** Pine Roe does not operate a petroleum gas system.

**Section 192.13 (c)** Company Operation, Maintenance and Emergency response plans are reviewed annually not to exceed 15 months.

**Section 192.16** Service lines are company owned and are plastic. No further customer notification is necessary.

**Section 192.225 thru 192 .245** Welding of steel pipelines is not applicable. Pine Roe only uses plastic ASTM D2513 approved pipe for natural gas service in its system.

### **Subpart F**

**Section 192.273** Company uses Manufactures joining procedures in all of its installations.

**Section 192.285** Joining certification for employees are on file and conducted in accordance with manufactures recommendations and specifications.

**Section 192.287** Visual inspections are conducted by qualified joiner.

### **Subpart G**

**Section 192.303** General construction requirements are limited to mains and services. Only approved (ASTD2513) piping and fittings are used in installation. Tracer wire and warning tape are installed and depth of cover is 24 inches for mains and 16 inches for services. Test pressure is 90 psig for mains and services, the test medium is air and the duration is 1 hour.

**Section 192.305** Pine Roe Natural Gas does all of its new construction and pipeline repair and follows its general construction requirements as specified in 192.303.

## Subpart H

**Section 192.353** Customer meters and service regulators are installed at the customer building wall as close as possible to the point of the service line entrance to the building, and are readily accessible. They are protected from corrosion by painting and are inspected for atmospheric corrosion when the meter reading is taken. The customer service regulators are outdoors and they are protected from rain and insects. If the service regulator were to vent, the gas would vent freely.

Each meter is installed with a meter bracket that is designed to minimize any anticipated stress upon the connecting meter and piping. All connections to the meter are made of material that is not easily damaged and insulating unions will be installed.

Valves with locking devices are installed on each meter set and all connections are located at the top of the main. If there is a probable risk of external damage to the meter set, Pine Roe Natural Gas will evaluate the risk on a case by case basis and make any changes necessary to protect the meter set. Currently there are not situations that warrant this action.

**Section 192.379** New Service Lines not placed in service upon completion of installation will have the valve closed and locked to prevent flow of gas to the customer to prevent any unauthorized operation.

**Section 192.381** Excess flow valves will be installed on all new or replaced service lines.

## Subpart I

Pine Roe Natural Gas does not have any jurisdictional steel lines within its system. In regards to atmospheric corrosion, evaluation of its meter sets and appurtenances, will be conducted during the scheduled meter reading. Inspections will be recorded on Form 13 Atmospheric Corrosion Control Inspection and any deficiencies found will be corrected at time of discovery.

Pine Roe Natural Gas does not have any transmission, cast iron or ductile iron in its system.

### **Subpart J**

**Section 152.501** All newly installed pipelines and main will be pressure tested at 90 psig for 1 hour and will be recorded on the Pipeline Test Report Form 16. All potentially hazardous leaks will be located and eliminated prior to further testing.

### **Subpart K**

**Section 192.551** Pine Roe Natural Gas does not have any current or future plans to up rate its system.

### **Subpart L**

**Section 192.605** Operations and Maintenance Plan.

Pine Roe Natural Gas has revised its plan for the operating year 2013. Any reference to emergency response will be addressed in the emergency plan that is included in this O&M plan. The O&M plan will be reviewed annually not to exceed 15 months.

This plan and the emergency plan are on file in the office located at 151 Hotel Drive, Clarion, Pa. and copies are carried in the employee vehicle.

**Section 192.605 (b)** Considering the size to Pine Roe Natural Gas and its 170 , customers Pine Roe is privileged to have a personal relationship with all of its customers and face to face communication is common place in this community. However, if there is any information that needs communicated to its customers Pine Roe will attach notices with their billing. Pine Roe has instructed its customers on the odor of gas and situations to consider when reporting gas leaks, blowing gas, odor of gas and gas outages.

In consideration of those engaged in excavation activities, Pine Roe is aware of persons conducting excavation in the Clarion Area. There is not a significant number of non-English speaking people in this area.

Pine Roe Natural Gas does not have any transmission lines nor does it qualify to report safety related conditions under 191.23.

All operating and maintenance and repair functions are carried out in accordance with each of the requirements of this subpart. Construction records, maps and operating history are available to the operational personnel.

Gathering data for any incident will be included on the Pipeline and Hazardous Materials Safety Administration Incident Report for Gas Distribution System PHMSA Form F 7100.1 (Rev. 01-2010)

When a portion of the main needs to be shut down, the appropriate valves will be closed slowly. Any additional shut down will be done by "squeeze off", with appropriate squeeze of tools. All effected customer meters will be turned off at the meter.

When returning system to service make sure all effected customer meters are closed. Introduce gas into the main by opening the valve slowly. When removing squeeze tools use appropriate grounding equipment and consider elimination of static electricity by soaking burlap or rags with soapy water and wrapping them around the main slightly downstream of the squeeze tool.

Pine Roe takes adequate precautions in excavation of trenches, buy terracing all excavations and providing a non hazardous area for its employees to work. Every effort will be made to reduce the possibility of accidental ignition. Fire extinguishers are staged at each excavation.

Once the system is back in service choose a purge point at the far end of the system in question. Continue to purge until 100% gas is read on the Combustible Gas Indictor. Turn off customer appliances and begin to turn on meters and continue with light up. If customer is not home do not unlock the meter and turn on service until the customer is notified and appliances can be relit according manufactures specifications.

All work will be reviewed by John Habjam owner.

Since Pine Roe operates under 60 psig, no additional over pressure protection is required when using customer service regulators.

Any odor of gas reported in or around a building will be considered a hazardous leak and immediate action will be initiated and continued until issue is resolved.

Any foreseeable malfunction of a component or deviation from normal operations, or personal error will be addressed immediately.

Abnormal operating conditions would include but not limited to, overpressure or customer has low gas pressure or gas outage or hears blowing gas.

Pine Roe is aware of any persons excavating; in and around the pipeline; without notification of appropriate One Call Notice.

## Subpart L

### Damage Prevention

**Section 192.614** In an effort to reduce third party damage Pine Roe is a member of the Pennsylvania One Call System. Pine Roe also participates in contractor meeting sponsored by the Pipeline Group.

Pine Roe's damage prevention program includes and is not limited to identifying individuals who may be conducting excavation in or around its facilities. Site visits are conducted as necessary to insure that a best practice; as outlined in the Common Ground Alliance; are followed.

Pine Roe conducts continuing surveillance in and around its system on a daily basis. Pine Roe is familiar with excavators, landscapers, and fence installers in the area and commutates with them.

Excavation activities include excavation, blasting, boring, tunneling, and backfilling, the removal of aboveground structures by either explosive or mechanical means or other earthmoving operations.

When Pine Roe is engaged in excavation activities all One Call and Common Ground Best Practices are followed.

## EMERGENCY PLAN

**Section 192.615(a)** The purpose of this emergency plan is to establish written procedures to make safe and minimize the hazard resulting from gas leaks or a pipeline emergency. In accordance with PUC regulation 59.33 Safety, Pine Roe Natural Gas will at all times use every reasonable effort to properly warn and protect the public from danger, and shall exercise reasonable care to reduce the hazards to which employees, customers, and others may be subjected to reason of its equipment and facilities.

A map of the system is available to maintenance personnel and they will be instructed to familiarize themselves with the locations of the valves that may be used in an emergency.

**EMERGENCY SITUATIONS** In case of a major leak, broken gas main or service, fire or explosion, and upon learning of the incident personnel are instructed to call:

Fire Department: 814-226-9140

Police: 814-226-9140

Ambulance: 814-226-1248

Maintenance personnel will follow the procedures for prompt and effective response to each of the following type of emergencies. The following general procedures apply.

### **Investigation of gas leaks:**

- I. Gas leaks inside a building.
  - (a) Caution building occupants to evacuate the building.
  - (b) Caution occupants' when leaving the building;
  - (c) **DO NOT** turn on or off any electrical switches.
  - (d) **DO NOT** use matches, lighters or any gas or electrical appliances.
  - (e) **DO NOT** use the telephone in the home, if they are on the phone tell them to put it down do not hang it up and leave the building.
  - (f) **DO** leave the home immediately until further notice.
  - (g) Eliminate ignition sources; turn off gas meter.

(h) Alert additional personnel with emergency equipment.

II. Gas leaks outside.

(a) Faint odor or low concentration of gas a house or building foundation.

1. Make every effort to determine source of leak by bar holes and Combustible Gas Indicator.

(b) Strong odor or high concentration of gas shown on CGI at house foundation.

1. Protect people first.
2. Evacuate the building, turn off gas meter.
3. Alert additional personal with emergency equipment.
4. Notify the fire department.
5. Keep people away from the building

(c) Broken gas line.

1. Protect people first.
2. Clear all unauthorized persons from the area, eliminate any ignition sources; turn off gas meters.
3. Check adjacent structures and sewers for gas migration and evacuate if necessary.
4. Notify the police and fire department.
5. Alert and caution all residents.
6. Keep people clear of the area do not allow residents to reenter their homes until the threat of explosion is clear.

III. Explosion or fire involving the gas mains or located near the gas mains or services.

1. Protect people first.
2. Alert and caution all residents.
3. Turn off the gas meter.
4. Alert addition personnel with emergency equipment (911).
5. Notify the police and fire department.
6. Secure the area.

IV. Natural Disaster. The appropriate procedures listed above will be followed for natural disasters that cause gas leakage, fire or explosion.

**Emergency Notification List**

When a gas incident occurs Pine Roe Natural Gas will notify the National Response Call Center at the earliest practical moment and notify the Public Utilities Gas Safety Division as soon as possible. This is a requirement when there is an injury or fatality or when it appears that more than \$50,000.00 in property damage has occurred. (See definition of incident).

Each notice shall be made by telephone to 800-424-8802 and shall include the following information.

- (1) Names of operator and person making the report and their phone numbers
- (2) The location of the incident.
- (3) The time of the incident.
- (4) The number of fatalities and personal injuries, if any.
- (5) All other significant facts that are known by the operator those are relevant to the cause of the incident or extent of the damages.

An incident report will be submitted to the Department of Transportation on form RSPA F 7100.1 as soon as practicable but not more than 30 days after detection of the incident.

National Response Call Center	800-424-8802
Paul Metro Gas Safety Pa PUC	717-554-5498

**Restoring Service After an Outage**

After necessary repairs are made, all affected customer meters will remain off until the main line is purged and 100% gas is reached at the purge point. Customers will be systematically turned on appliances relit. If a residence is vacant notice will be given that the natural gas is turned off and advise the customer to call Pine Roe for service restoration.

## **Investigation of Failures**

As soon as practical, Pine Roe Natural Gas will investigate any system failure to determine the cause. This will include submission of samples of the failed material or component for laboratory analysis when appropriate. All employees will have access to a copy of the Emergency Plan.

Pine Roe Natural Gas reviews its plan with its employees on a continuing basis, communicates change and evaluates the effectiveness of its employees at that time.

All efforts are focused toward preventing the reoccurrence of any failure, making the area safe and protecting the public and its employees first.

## **SUBPART M**

### **MAINTENANCE**

**Section 192.703** Pine Roe's distribution main and services are constructed of plastic, however if any section of this main is considered to be unsafe it will be removed and replaced.

**Section 192.707** Pipeline markers are installed with the word "Warning Gas" with letters 1 inch high and ¼ inch stroke, with the Name Pine Roe Natural Gas and a phone number where Pine Roe can be reached 24 hours a day.

**Section 192.721** Pine Roe patrols its distribution mains semi annually and is recorded on Form 4 Patrolling of Pipeline Systems. Its leak survey is conducted annually.

**Section 192.725** All service lines that are disconnected for any reason will be tested at operating pressure for 30 minutes before they are placed back in service.

**Section 192.727 and 59.36** Any service line that is inactive for 3 months, with no prospect for future use, will be disconnected from the main. All inactive services will be leak surveyed as though they were active. Any building that is being demolished will have the service line disconnected from the main. All meter sets are equipped with vales that have a locking device.

If a meter is removed from service, the service valve will be locked and both pipe ends sealed.

**Section 192.747** Key valves will be designated on the system map and will be inspected annually not to exceed 15 months for accessibility, operation, free of impediments to include water and soil, lubricated, and repaired as necessary and recorded on Form 9 Valve Inspection Report.

**Section 192.751** Whenever gas is being vented into the atmosphere for any reason a fire extinguisher will be present, warning signs posted when necessary, any source of ignition will be removed, to prevent accidental ignition.

## **SUBPART N**

### **QUALIFICATION OF PIPELINE PERSONNEL**

#### **Section 192.801**

This document incorporates specific policies and procedures that Pine Roe Natural Gas will utilize in achieving compliance with 49 CFR Part 192 and specifically section 192.801. The policies and procedures set forth herein commenced April 27, 2001.

#### **Definitions (49 CFR 192.803)**

##### **a. Identification (49 CFR 192.801)**

For the purpose of this plan, a covered task is an activity that is (1) performed directly on the pipeline facility, which is (2) an operation or maintenance tasks; and (3) is performed as a requirement of 49 CFR Part 192 and (4) which affects the operation or integrity of the pipeline.

##### **b. Table of Covered Tasks**

The Company shall identify tasks which are subject to the OPS regulation on Operator Qualifications in 49 CFR 192.801-809 and provide a list in the Company's "Table of Covered Tasks" (EQP). Figure 1.

##### **c. Changes to Covered Tasks**

Whenever the Company initiates changes in procedures or requirements that affect covered tasks, the Company shall communicate those changes and any associated procedural changes to the individuals performing those covered tasks.

### **Evaluation Process (49 CFR 192.805)**

Employees shall be evaluated to determine their qualifications for performing the identified covered tasks in accordance with the Company's "Employee Qualification Program" (EQP).

#### a. Evaluation of Employees Performing Covered Tasks

See "Evaluation Table" on page 5 for guidance on acceptable evaluation methods.

#### b. Unqualified Individuals

Individuals that are not qualified under the definition above and pursuant to 49 CFR 192.801 may perform a covered task if directed and observed by an individual who is qualified.

#### c. Mutual

#### d. Evaluation after an incident

If the Company has reason to believe that an individual employee's performance of a covered task contributed to an incident as defined in 49 CFR Part 191, the Company shall evaluate the individual in accordance with the "evaluation" process required in this plan.

#### e. If employee is no longer qualified

If the Company has reason to believe that an individual employee is no longer qualified within the meaning of 49 CFR Part 192, the Company shall evaluate the individual in accordance with the "evaluation" process required in this plan.

#### f. Evaluation Intervals

Where appropriate, the Company shall establish time intervals in which to reevaluate the qualifications of individuals performing covered tasks.

## **1. PERFORMANCE HISTORY (49 CFR 192.809 (c))**

Pine Roe Natural Gas used work history review method to evaluate an employee's qualification, the review included the following:

1. A search of existing records for documentation of past satisfactory performance of covered tasks.
2. Verification that the individual's work performance history contains no indications of substandard work or
3. Involvement in an incident, as defined in Part 192, caused by an error in performing a covered task.
4. Verification that the individual has successfully performed the covered task on a regular basis prior to the effective date of 49 CFR 192.801.

## **RECORD KEEPING (49 CFR 192.807)**

The qualification records shall include:

- a. Identification of qualified individuals
- b. Identification of covered tasks the individual is qualified to perform
- c. Date(s) of current qualification

Records supporting an individual's current qualifications shall be maintained while the individual is performing the covered task. Records of prior qualification and records of individuals no longer performing covered tasks shall be retained for a period of five years.

## **GUIDELINES FOR DETERMINING COVERED TASKS**

A four-part test shall be used to determine whether a task is a "covered task" **A task must meet all four criteria to be a covered task:**

1. The task is performed on a pipeline facility subject to Part 192,
2. The task is an operation or maintenance task,
3. The task is performed as a requirement of Part 192 and,

4. The task affects the operation or integrity of the pipeline.

**Evaluation Table**

The following table shows the Company methods to be used for transitional qualification of current employees during the 3 years after the effective date of the rule, for initial qualification of new or existing employees being qualified in a task they have not previously performed, and for subsequent qualification of individuals as specified in this Pipeline Operator Qualification Plan.\* (cont'd next page)

**Operator Qualification Plan For Pine Roe Natural Gas**

Evaluation Method	Transitional	Initial	Subsequent
Written exam	NO	NO	NO
Oral exam	YES	YES	YES
Work performance history review	YES	May not be used as the sole evaluation method	May not be used as the only evaluation method after the three year Compliance date
Performance on-the-job	YES	YES	YES
On-the-job training	YES	YES	YES
Simulation			
Other(list )	YES	YES	YES

**Operator training outline:**

Characteristics of Natural Gas:

Potential ignition sources:

Causes & effects of Carbon Monoxide:

Emergency First Response Training:

Plastic Qualification:

Bedding & backfilling:

Control of Static Electricity using Squeeze tools:

Installation of excess flow valves:

Regulating gas flow, residential metering and Setting meters:

Leak Classification & Pinpointing:

Mechanical Fitting installation:

Crossing:

Damage Prevention Program and locating underground facilities:

**Transitional qualification** means qualification completed during the period between the effective dates of 49 CFR Section 192.801. The rule and the three-year compliance date, of individuals who have been performing a cover task on a regular basis, prior to the effective date of the rule. Pine Roe Natural Gas received its OQ Training at Equitable Gas Company. Completed by 10-28-2002

**Initial qualification** means qualification, at any time, of individuals who were not performing a covered task on a regular basis prior to the effective date of the rule.

**Subsequent qualification** means evaluation of an individual's qualification, after "transitional" or "initial" qualification, at the interval established by the operator.

**Figure 1**

**Covered Tasks**

<b>Customer Service</b>		
Turn on/turn off a meter	20 years	
Leak investigation	20 years	
Setting a meter & regulator	20 years	
<b>Damage Prevention</b>		
Locating & marking facilities	20 years	
<b>Gas Control</b>		
Controlling & monitoring gas pressures & flows	20 years	
<b>Leak Repair</b>		
Repair distribution line leaks	20 years	
Repair transmission line leaks	20 years	
<b>Maintenance/Operations</b>		
Joining pipe materials other than plastic or steel during maintenance	20 years	
Repair a non-leaking damaged pipe	20 years	
Installing a pipe by trenching for maintenance	20 years	
Installing a pipe by insertion	20 years	
Inspect pipe at a maintenance job for damage	20 years	
Performing a pressure test on existing pipe	20 years	
Maintaining service & curb boxes	20 years	

Performing an electrofusion on PE pipe	20 years	
Performing a butt fusion on PE pipe	20 years	
Times New Roman	20 years	
Performing a sidewall fusion of PE pipe	20 years	
Joining PE pipe using mechanical connections	20 years	
Install & repair tracer wire	20 years	
Inspecting PE fusion for maintenance	20 years	
Bedding & backfilling	20 years	
Stopping gas flow less than 1 PSIG	20 years	
Stopping gas flow using squeeze tools on PE pipe	20 years	
<b>Maintenance/ Operations (Cont.)</b>		
Tapping & stopping gas flow less than 1PSIG	20 years	
Pressure testing	20 years	
Purging a pipeline	20 years	
Joining steel pipe using mechanical connections	20 years	
Abandonment or deactivation of mainlines	20 years	
<b>Patrolling &amp; Inspection</b>		
Conducting leakage surveys	20 years	
Patrolling & inspecting pipeline	20 years	
<b>Service Lines</b>		
Abandon service line	20 years	
Extend or cut back on existing service line	20 years	
<b>Valve Maintenance</b>		
Inspect valves	20 years	
Repair & maintain distribution line valves	20 years	
Repair & maintain transmission line valves	20 years	
Lubricate distribution line valves	20 years	
Lubricate transmission line valves	20 years	
<b>Measurement &amp; Regulation</b>		
Inspect recording gauge	20 years	
Testing overpressure protection	20 years	
<b>Corrosion</b>		
Inspecting for atmospheric corrosion	20 years	

### COVERED TASKS

Covered Task	Requalification Interval	
Inspecting the condition of exposed pipe or pipe coating	20 years	

## **Title 66 Pennsylvania Code Requirements**

**Section 59.12** Records of interruption of service showing time, duration and cause of interruption will be kept on file and reported to the Commission as soon as practical.

**Section 59.13** Records of complaints will detail explaining the nature of the complaint and the resolution of said complaint will be kept on file.

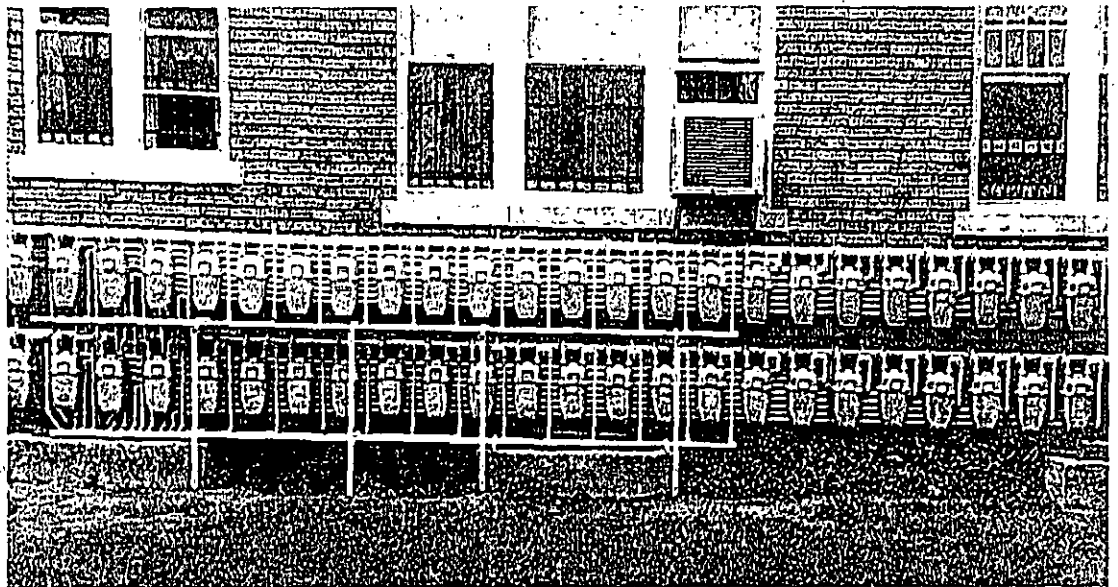
**Section 59.34** Records of the Leakage Survey will be recorded on Form 4 patrolling records.

**Section 59.33/59.37** Information of Pine Roe's facilities, in recorded on its system maps.

**Section 59.33 (c-d)** All reports, maps and records and any supplemental data required by the Pennsylvania Public Utility Commission will be readily available to the Commission Staff.

Small Operator Guide

# Guidance Manual for Operators of Small Natural Gas Systems



June 2002

RECEIVED

MAR - 4 2014

PA PUBLIC UTILITY COMMISSION  
SECRETARY'S BUREAU



US Department of Transportation  
Research and Special Programs Administration  
Office of Pipeline Safety

## TO THE READER

The U.S. Office of Pipeline Safety promotes the safe transportation of natural gas by pipeline. This guidance manual for operators of small natural gas systems is part of our commitment to pipeline safety. This manual was developed to provide an overview of pipeline compliance responsibilities under the federal pipeline safety regulations. It is designed for the non-technically trained person who operates a master meter system, a small municipal system, or small independent system.

The federal government recognizes that most operators of small natural gas systems have not had extensive qualification in operation and maintenance of a gas system. In addition, many of the safety regulations are in technical language that addresses generic requirements for both large and small natural gas systems. This manual attempts to simplify the technical language of the regulations.

For certain critical regulations, this manual provides details of methods of operation and selection of materials that will satisfy the pipeline safety regulations. However, this is often only one of several allowable options. This manual provides a set of examples that operators of small natural gas systems can use to meet the minimum requirements of the pipeline safety regulations. For example, requirements for pressure testing vary throughout the pipeline safety regulations. The test pressure used in this manual is usually 100 pounds per square inch to provide clarity and consistency to small operators unfamiliar with the intricacies of natural gas pipeline operations. The operator is referred to 49 CFR Part 192 for additional details and other options for reaching and maintaining compliance.

Our aim is to provide basic information to operators of small natural gas distribution and master meter systems to ensure compliance with the federal gas pipeline safety regulations. It is hoped that this document will assist operators in achieving and maintaining a safe and efficient natural gas system. The result will enhance public safety – the essential goal of the Office of Pipeline Safety.

Stacey Gerard  
*Associate Administrator for  
Pipeline Safety*

## ACKNOWLEDGEMENTS

The Office of Pipeline Safety (OPS) gratefully acknowledges the contributions of the many individuals and organizations who contributed their time and expertise to this manual. Most especially, it is a product of close cooperation with the Small Operators Manual Committee of the National Association of Pipeline Safety Representatives (NAPSR). OPS extends special thanks to RSPA's Transportation Safety Institute (TSI) for its exemplary efforts in the revision and publication of this manual.

The following organizations significantly contributed to the revised manual:

Aegis Loss Control Services, Inc.  
American Gas Association (AGA)  
American Petroleum Institute (API)  
American Public Gas Association (APGA)  
Dresser Industries, Inc.  
Fisher Corporation  
Heath Consultants  
Louisiana One Call, Inc.  
Midwest Energy Association (MEA)  
Natural Gas Odorizing, Inc.  
National Association of Corrosion Engineers (NACE)  
Perfection Corporation

The revision and publication of this manual is an example of constructive partnership among government, the pipeline industry, and industry and professional organizations.

# TABLE OF CONTENTS

	<u>PAGE</u>
CHAPTER I – INTRODUCTION AND OVERVIEW	
Introduction.....	I-1
Overview.....	I-2
CHAPTER II – REGULATOR AND RELIEF DEVICES	
Basic Concept .....	II-1
Pressure and Force .....	II-2
Flow and Throttling .....	II-3
Basic Names and Terms.....	II-7
Overpressure Protection.....	II-9
Pressure Relief .....	II-12
Monitoring .....	II-13
Automatic Shutoff.....	II-14
CHAPTER III – CORROSION CONTROL	
Federal Requirements .....	III-1
Principles and Practices of Cathodic Protection .....	III-5
Fundamental Corrosion Theory .....	III-15
Types of Cathodic Protection .....	III-16
Initial Steps in Determining the Need to Cathodically Protect a Small Gas Distribution System.....	III-18
Criteria for Cathodic Protection.....	III-21
Coatings .....	III-23
Common Causes of Corrosion in Gas Piping Systems.....	III-25

## CHAPTER IV – LEAK DETECTION

Methods of Detecting a Leak .....	IV-1
Description of Leak Detection Equipment .....	IV-3
Recommended Method for Surface Gas Detection Survey with FI Unit (Natural Gas System Only) .....	IV-7
Odorization Equipment .....	IV-9
Records .....	IV-14
GPTC – Guide Material for “Leak Classification and Action Criteria” .....	IV-14
Follow-up Inspection .....	IV-14

## CHAPTER V – UNACCOUNTED FOR GAS

## CHAPTER VI – REPAIRS AND NEW CONSTRUCTION

Planning Ahead .....	VI-1
Excavation .....	VI-2
Emergency Excavation .....	VI-2
Precautions to Avoid Damage .....	VI-2
Excavation: Repair of Damage .....	VI-2
Recommendation .....	VI-3
Pipe Installation, Repair, and Replacement: General Comments .....	VI-3
Metallic Pipe Installation .....	VI-3
Plastic Pipe Installation .....	VI-4
Repair Methods – Plastic and Metal .....	VI-17
Materials and Equipment Qualified for Use in Natural Gas Systems .....	VI-19
Pipe .....	VI-19
Valves .....	VI-22
Flanges and Flange Accessories .....	VI-22
Regulators and Overpressure Protection Equipment .....	VI-23
Other Equipment .....	VI-23
Welding Requirements .....	VI-24
Common Construction Practices .....	VI-28

CHAPTER VII – PROPER LOCATION AND DESIGN OF CUSTOMER METER AND REGULATOR SETS

Customer Meters and Regulators: Location .....	VII-1
Customer Meters and Regulators: Protection From Damage .....	VII-2
Customer Meters Installations: Operating Pressure .....	VII-2
Service Lines: Location of Valves.....	VII-3
Common Problems at Service Riser and House Regulators.....	VII-7

CHAPTER VIII – PLANS AND REPORTS REQUIRED BY THE FEDERAL GOVERNMENT

Plans Required by the Federal Government .....	VIII-1
Operations and Maintenance Plans.....	VIII-1
Operations and Maintenance Plans Must Contain the Following Components:.....	VIII-2
Emergency Plans.....	VIII-16
Reports Required by the Federal Government .....	VIII-26
Incident Report .....	VIII-26
Safety-Related and Condition Reports .....	VIII-27
Annual Reports .....	VIII-28

APPENDIX A – GLOSSARY AND ACRONYMS	A-1
------------------------------------	-----

APPENDIX B – SAMPLE FORMS	B-1
---------------------------	-----

APPENDIX C – STATE AND FEDERAL REGULATORY AGENCIES	C-1
--	-----

## CHAPTER II

### REGULATOR AND RELIEF DEVICES

This chapter contains a simplified description of the pipeline safety requirements. The complete text can be found in 49 CFR Part 192.

#### BASIC CONCEPT

In understanding the equipment used to regulate the pressure of natural gas, it is helpful to be familiar with some fundamental physical units and concepts. Four are particularly important. Taken in pairs they are:

#### PRESSURE and FORCE

#### FLOW and THROTTLING PRESSURE

In the natural gas business the commonly used pressure units are:

pounds per square inch .....psi

ounces per square inch.....osi

inches water column... in. w.c

For convenience, the three units are usually referred to as pounds, ounces, and inches.

It is important to remember that "pounds," "ounces," and "inches" are the short form of expressing pressure units. There really is no such thing as a pound of pressure or an ounce of pressure. They are incomplete terms. Pressure is defined as force per unit area. Pounds and ounces express only the "force" portion of that definition. The fourth unit of "area" is missing. Thus, the complete terminology should be "pounds per square inch" and "ounces per square inch."

When gas is under pressure, it exerts a given force against each unit of exposed area. For example, gas at a pressure of 10 psi pushes with a force of 10 pounds against each square inch of surface exposed to the gas. Gas at a pressure of 5 ounces (remember... ounces per square inch) pushes with a force of 5 ounces against each square inch of surface exposed to the gas.

Such units as pounds or ounces per square foot, per square yard, or other unit area are quite correct. However, for the gas business the unit area used is the square inch. And, to repeat, the complete expressions are pounds per square inch (psi), and ounces per square inch (osi).

Returning to psi, there are some other terms to note as follows:

pounds per square inch absolute....psia

pounds per square inch gauge.....psig

The relationship between the two is simple:

$$\text{psia} = \text{psig} + \text{atmospheric pressure}$$

Absolute pressure (psia) uses a perfect vacuum as the zero point. A perfect vacuum is 0 psia.

Gauge pressure (psig) uses the actual atmospheric pressure as the zero point. In Miami, sea level atmospheric pressure is 14.7 psia. Thus, 0 psig is 14.7 psia in Miami. In Denver (5,280 feet elevation), atmospheric pressure is 12.1 psia. And 0 psig for Denver is 12.1 psia.

Inches of water column (in. w.c.) are often used to express the pressure at which gas is delivered to residential customers. Pressure measurement in inches is usually done with an instrument called a manometer (see FIGURE II-1). The important relationships to remember are these:

$$\text{For inches of water column:} \quad 1 \text{ psig} = 27.71 \text{ in. w.c. (at sea level)}$$

Note the physical limitations to pressure measurement with the manometer. The highest pressure that could be measured with a "U" type manometer 5-feet high would be only a little over 2 psig (56 in. w.c.). However, note also that it offers a very precise way of measuring low pressures.

When expressing pressure in inches, it is necessary to identify the liquid. To put it another way, there really is no such thing as an inch of pressure. Instead, it is inches of a particular liquid, in the gas business generally water or mercury. Thus, the correct expression is inches water column (in. w.c. or in. H<sub>2</sub>O). Figure II-1 illustrates how to read a manometer.

### PRESSURE AND FORCE

Force is simply a push or a pull. It is measured in pounds.

Note that pounds of pressure is incomplete (it should be pounds per square inch) whereas pounds of force is complete. Thus, it would be "x" pounds of pushing force or pulling force.

FIGURE II-2 shows the relationship between pressure and force. Note that pressure is used to create a total force. Also, note how much force (200 pounds) can be created with only a small amount of pressure (2 psig.) It is all a matter of diaphragm area or piston area. A diaphragm, of course, is simply a low friction, tightly sealed, short stroke piston (just the thing for use in regulators).

In FIGURE II-2, the effective area of the piston or diaphragm is 100 square inches (100 in.<sup>2</sup>). Applying 2 psig pressure to the 100 in.<sup>2</sup> area gives an upward pulling force of 200 pounds (100 in.<sup>2</sup> x 2 lbs/in.<sup>2</sup> = 200 pounds).

Note that the pressure above both the diaphragm and the piston is atmospheric (0 psig). The differential pressure across the diaphragm and across the piston is 2 psi ( $2 \text{ psig} - 0 \text{ psig} = 2 \text{ psi}$ ).

Note also that the effective diameter of the diaphragm and the piston is only about 11 inches. An 11 inch diaphragm is not very large. This is quite a common size for regulators, particularly on commercial and industrial applications. But an 11 inch diaphragm has a large area ( $100 \text{ in.}^2$ ). It does not take much pressure (2 psig, for example) to develop a large total force (200 pounds).

### FLOW AND THROTTLING

To throttle the flow of a fluid is to allow only a certain amount to flow and to hold back the remainder. A faucet provides a good example. How much water is wanted determines how far the faucet is opened. The faucet (a valve) is a throttling device. Depending on how far it is opened, it allows only a certain amount of water to flow and holds the rest back. It restricts flow to a certain amount.

Throttling is a basic function in a regulator. The part that throttles is a valve. It allows only a certain amount of gas to flow. The valve part of a regulator is a type of variable restrictor.

Not all valves can be used for throttling (i.e., used as a variable restrictor). Some (like many gate valves) are designed to be either wide open or fully closed. If used in an intermediate position (one-third open, half open, three-fourths open, etc.), they become unstable. They may chatter, rattle, hammer, etc. They are unsatisfactory.

For a regulator, the valve must be mechanically stable from wide open to as small a flow as possible. In addition, it must change the flow smoothly as it is opened or closed.

The most widely used valve for regulators is the single-port, unbalanced, globe valve. It is economical in construction yet provides good throttling. In addition, it has a smooth stroke, little friction, and good shut-off (lock-up) characteristics.

FIGURE II-1 U TUBE MANOMETER

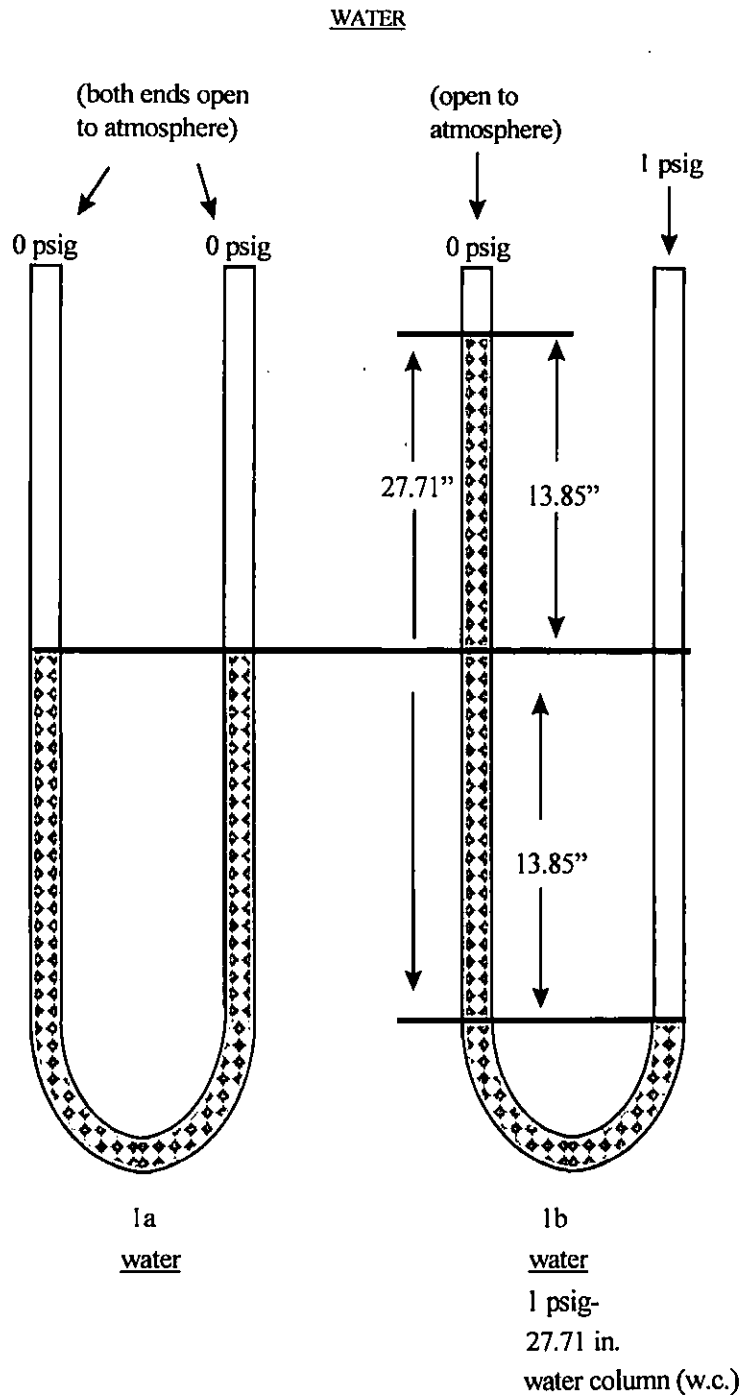


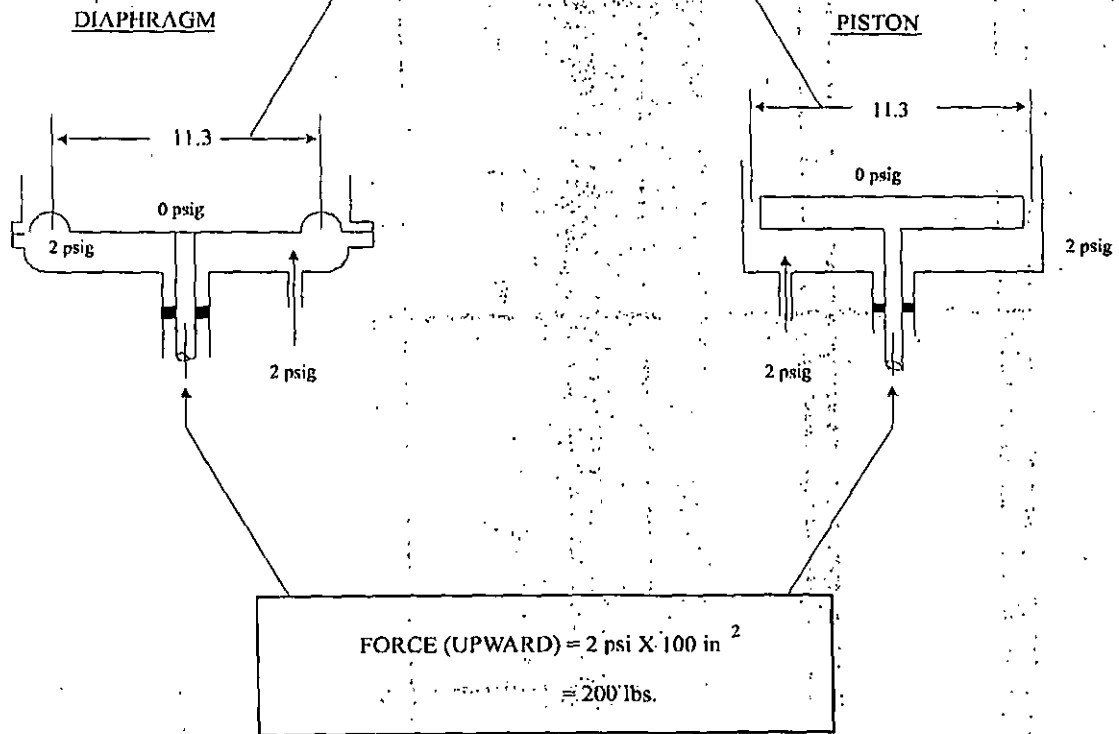
FIGURE II-2

EFFECTIVE AREA OF DIAPHRAGM AND PISTON

$$\text{EFFECTIVE AREA} = \left( \frac{\text{DIAMETER}}{2} \right)^2 \times 3.1416$$

$$\left( \frac{11.3}{2} \right)^2 \times 3.1416$$

$100 \text{ in}^2$  (SQUARE INCHES)



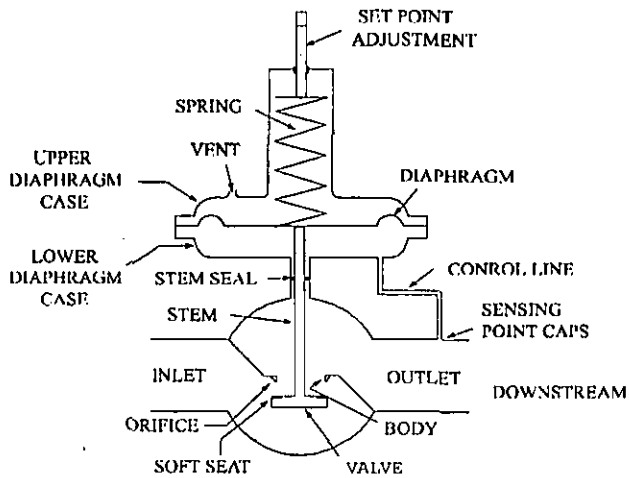
FORCE = PRESSURE X AREA

**FIGURE II-3**

**TYPICAL SINGLE PORT SPRING REGULATORS**

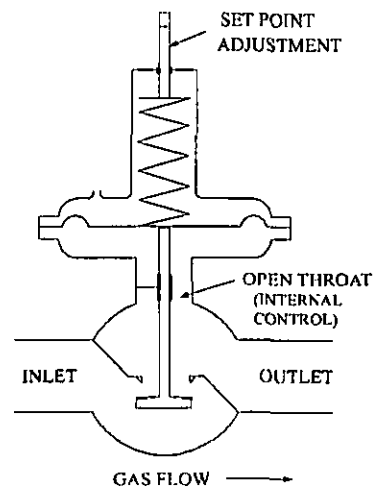
**Figure II-3A: Control Line**

STANDARD SPRING REGULATOR  
(WITH CONTROL LINE)

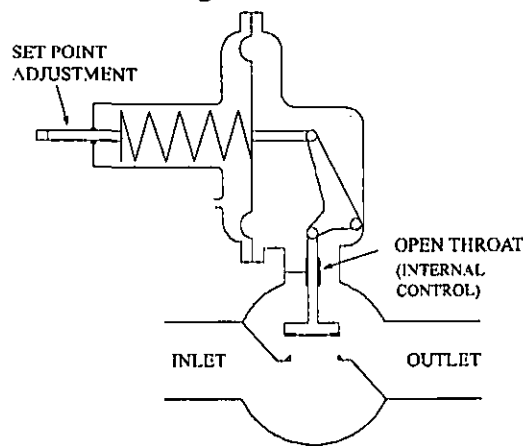


**Figure II-3B: Internal Control**

STANDARD SPRING REGULATOR  
(WITH INTERNAL CONTROL)



**Figure II-3C**



SERVICE REGULATOR  
(WITH INTERNAL CONTROL)

GAS FLOW →

FIGURE II-3 shows a simple section of a standard spring regulator. The various parts are labeled. For most master meter operators this will be the only type of regulator in the system. Service regulators are this type of regulator. Referring to FIGURE II-3, the following is a simple explanation of how it works.

1. Spring compression works to open the valve.

The rule is: The PRIMARY VALVE OPENING FORCE in a spring regulator comes from the spring (usually, spring compression).

2. The diaphragm works to close the valve.

The rule is: The PRIMARY VALVE CLOSING FORCE in a spring regulator comes from other pressure acting against the effective area of the diaphragm.

3. An increase in outlet pressure creates valve closing action. Conversely, a decrease creates opening action.
4. Set point (the outlet pressure a regulator is adjusted to deliver) is determined by spring compression. Turning the set point adjustment clockwise increases spring compression which increases set point, and vice versa.

Pilot type regulators are used at city gate stations or for large industrial customers. These regulators are more complicated than spring regulators. These types of regulators will not be discussed in this manual. A consultant should be used to select the correct type and size regulator for most applications except for house regulators.

### BASIC NAMES AND TERMS

Referring to FIGURE II-3, the inlet is the opening through which gas enters a regulator. The pressure of the entering gas is usually called the inlet pressure, although it could also be called the upstream or supply pressure.

The outlet is the opening by which gas leaves a regulator. The pressure of the exiting gas is usually called outlet pressure, although it could also be called downstream pressure.

In general, the more the inlet pressure exceeds the outlet pressure, the greater the amount of gas that can flow through the regulator, (to put it another way, the greater the capacity of the regulator). The difference between inlet and outlet pressures is sometimes called the differential across the regulator.

Piping on the inlet side is upstream and piping on the outlet side is downstream. As stated previously, a regulator takes higher pressure gas from the supply and reduces it to the pressure required by the load. To do this, something is needed on the regulator to adjust it for the specific pressure required. This adjustment is called the set point adjustment and on most of today's regulators it is a screw-type device of some kind, usually a simple adjustment screw. Set point is the pressure a regulator is adjusted to deliver. It is the pressure required by the load and, in general, is the same as the outlet pressure.

Note the control line referred to in FIGURE II-3A. It is also called a sensing line, impulse line, equalizing line or static line. The control line and the sensing point are vital parts of a regulator installation. They must be carefully planned and correctly installed if the regulator is to operate satisfactorily and safely.

Many regulators, particularly smaller ones, do not have the external control line shown in FIGURE II-3A. Instead, it is internal as represented by FIGURE II-3B. Called internal control, it is inside some form of open throat construction or venturi tube. However, whether located internally or externally, every regulator has a control line or the equivalent.

Control lines must be adequately protected against breakage. If they are broken, the regulator opens wide and this could result in the full upstream line pressure (that is high) being dumped into the low-pressure system. This can lead to a catastrophic situation.

The next item is the vent. While often appearing insignificant, the vent is important to a regulator. Regulators breathe. As the internals move in the work of controlling pressure, a regulator will inhale or exhale through the vent. Therefore, the vent must be adequately protected from obstructions such as dirt, insects, ice, etc. If an obstructed vent prevents a regulator from breathing, the diaphragm will not work properly.

In the event that the regulator fails to open, the higher pressure gas dissipates thru the vent.

Also, water can get inside a regulator through an improperly positioned and unprotected vent. Water inside a regulator can cause problems. Therefore, vents must be positioned and protected to keep the water out. This is particularly important on outdoor installations.

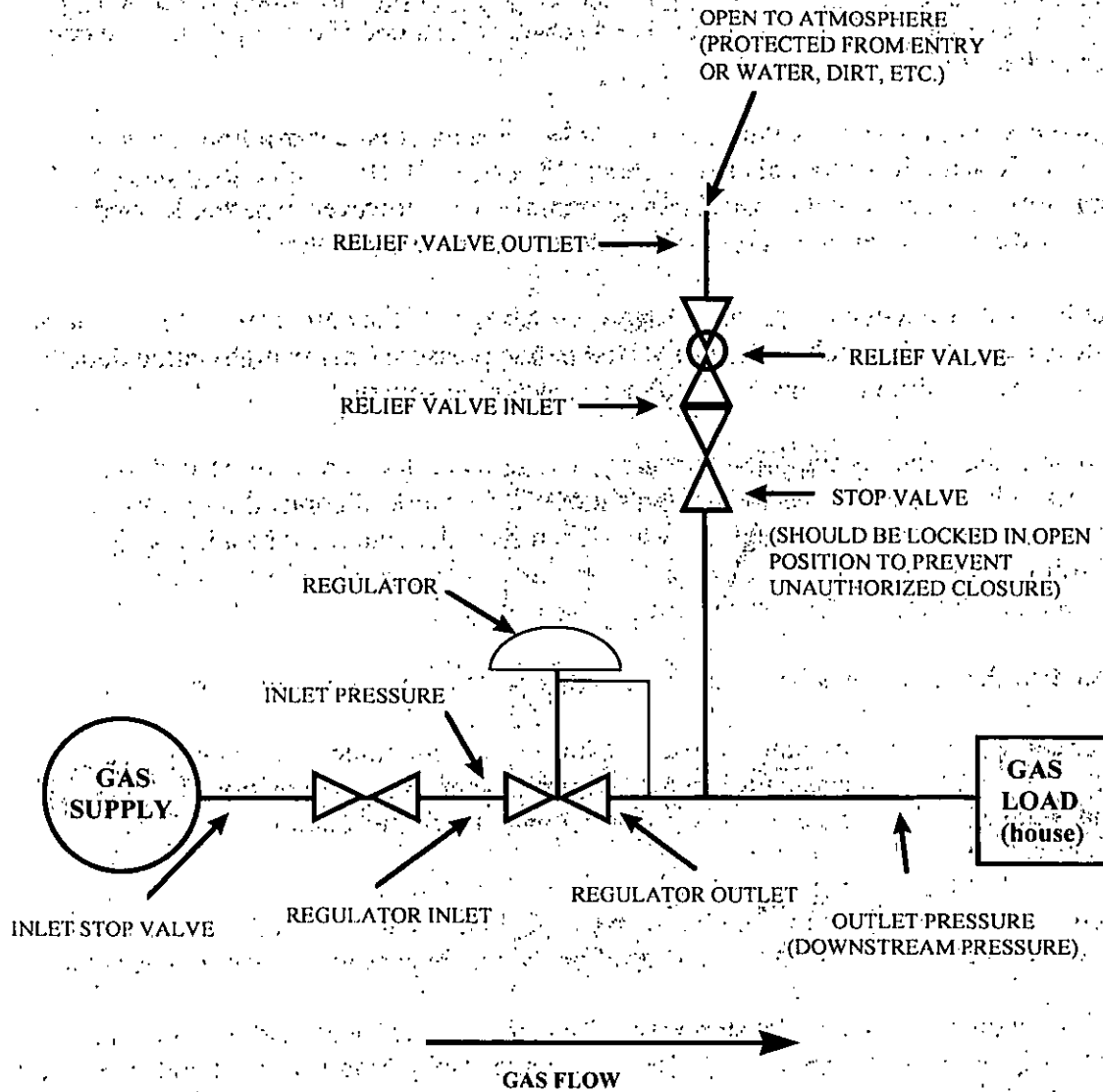
The last item is the stop valve (FIGURE II-4). A simple installation (such as at a house) usually has only one. A more complex installation such as a regulator station would have several stop valves (inlet stop valve, outlet stop valve, control line valve, bypass valve, and perhaps others).

The most important of all is the inlet stop valve. The inlet stop valve should be used with extra care, particularly when being opened. Do not open it until everything is correct and safe. Then open it slowly. Allow the inlet gas to enter slowly, and the pressure to build up slowly.

Stop valves make it possible to put a regulator into service or take it out of service. They make it possible to isolate a regulator for testing and servicing. Correct opening and closing sequences should be adequately understood (these are often specified in gas company standards and procedures). Understanding usage in case of an emergency is also important.

In most cases operators of small natural gas systems need to rely on a consultant for major repair work on regulator stations. The operations and maintenance plan must name the person who is responsible for determining when a regulator needs to be serviced. The operations and maintenance plan should also list those consultant(s) capable of working on regulator stations.

FIGURE II-4



### OVERPRESSURE PROTECTION

There are three basic methods of providing overpressure protection:

- Pressure Relief
- Monitoring
- Automatic Shutoff

Pressure relief is simply a dumping of excess gas safely into the atmosphere. The excess gas is that which would cause pressure to exceed the safety limit. The relief valve is the most widely used piece of equipment in this category. However, liquid seals and rupture discs may also be used.

There are two basic kinds of relief valves – self-operated and relay-operated. The spring-type relief valve is the most widely used. The pilot-operated type is also frequently used, and it offers more precise operation. The pilot operated type is more frequently used as pressures become higher and capacities greater. Monitoring involves a standby regulator. The standby prevents pressure from exceeding the safety limit.

The most widely used form of monitoring is standby monitoring. It is also called passive monitoring. It consists of two regulators in series, one of which is operating to control pressure while the other is a standby. The standby unit is normally further open than necessary, usually wide open. It takes that position because it is adjusted to a higher set point than the operating regulator. If an operating regulator failure causes outlet pressure to rise, the monitor takes over and holds pressure at its set point.

Two other forms of monitoring are sometimes used. One simply consists of two-stage regulation which, when designed for the purpose, can provide monitoring protection. The other is called override monitoring or working monitoring. With it, the upstream regulator must be pilot operated and have an extra pilot. During normal operation, the set provides two-stage regulation. In an overpressure emergency it protects in the same way as standby monitoring.

Automatic shutoff involves a valve that normally remains in the wide open position and allows the gas to flow freely. It is located in series with the regulator, either upstream or downstream, depending on whether it uses a control line or internal control.

If a regulator failure results in a rising outlet pressure, the shutoff closes automatically when pressure reaches its set point. It protects by shutting off the gas and remains closed until manually opened and reset.

In general, there are three things to consider in choosing overpressure protection systems:

1. Continuity of service – does the user, or the load, need to be continuously supplied with gas?
2. Containment – is gas released into the atmosphere or does it remain contained within the gas system?
3. Alerting – is there provision for notification or warning that an emergency has occurred and that the overpressure protection equipment has gone into operation?

The following is a comparison of the three basic overpressure protection methods (based on the foregoing three considerations).

## Pressure Relief

- **Continuity of Service.** In general, pressure relief valves do not interrupt gas service. They protect, while allowing gas to flow at a safe pressure. Customers continue to receive gas.
- **Containment.** Relief valves do not contain the gas. They protect by dumping the excess gas into the atmosphere.
- **Alerting.** Relief valves are usually good in this respect. They are noisy, particularly at full or near full blow. In addition, because the gas is odorized, the smell usually attracts attention. Another indication of overpressure is the rise in outlet pressure above normal, but this is probably the least effective notification.

## Monitoring

- **Continuity of Service.** Monitoring does not interrupt service. Like the relief valve, the monitor protects while allowing gas to continue flowing.
- **Containment.** Monitoring contains the gas. It prevents the gas from blowing into the atmosphere and keeps it inside the piping.
- **Alerting.** This is probably the main disadvantage of monitoring. Generally speaking, the only warning or notification is the rise in outlet pressure to monitor set point.

## Automatic Shutoff

- **Continuity of Service.** Automatic shutoff stops the flow of gas. It protects because it interrupts gas service by shutting off the gas.
- **Containment.** Automatic shutoff contains the gas. Like monitoring, it does not allow gas to blow into the atmosphere. It contains the gas within the piping.
- **Alerting.** In general, shutting the gas off results in good notification. Usually it is quickly noticed. However, there could be situations where it is not detected immediately and the lack of gas has undesirable or even serious results.

The next sections cover the three basic methods of overpressure protection in more detail.

## PRESSURE RELIEF

FIGURE II-4 is a diagram of a typical relief valve installation. The purpose of the relief valve is to prevent outlet pressure from rising to an unsafe level when there is a regulator failure.

In general, regulator failure would result in either too much or too little pressure downstream. The failure would leave the regulator in what could be called a "failed-open" condition (regulator too far open, even fully open – too much gas flow) or a "failed-closed" condition (regulator too far closed, even fully closed – not enough gas flow). A relief valve is only useful in a "failed-open" regulator condition – too much gas flow, resulting in downstream pressure above normal. Relief valves do nothing for a "failed-closed" regulator condition – too little gas.

A relief valve protects by discharging the excess gas into the atmosphere. As long as a regulator operates correctly and downstream pressure is normal, a relief valve remains closed. If the regulator fails and allows too much gas to flow (a "failed-open" condition for the regulator), downstream pressure will increase. The relief valve will remain closed until pressure reaches its set point. At that point it will begin opening and will continue to do so as the pressure continues to rise. It will open far enough to discharge all of the excess gas into the atmosphere. When it reaches that point, there will be no further rise in the downstream pressure and, if the relief valve and its installation are correctly sized, the pressure downstream will not be high enough to be unsafe.

Keep in mind that the relief valve does not discharge all of the gas into the atmosphere. It only discharges the excess. There is still a normal flow for the load. Customers continue to receive gas.

### **Relief Valve Sizing**

Sizing is vitally important. This applies not only to the relief valve itself, but also to the piping of the entire installation. A relief valve must be big enough to handle the maximum emergency. When properly installed and maintained, relief valves are very dependable. The question is not so much whether it will work, but rather whether it is large enough to provide full protection during a maximum emergency. When a relief valve is in full operation, it can discharge an enormous volume of gas into the atmosphere. For that reason they cannot be used everywhere. This must be carefully considered when a relief valve installation is being planned and engineered. The vital questions are these: What happens to the gas after it leaves the relief valve? Will it disperse harmlessly? Or, could it create another emergency? This matter is addressed in 49 CFR §192.199(e).

FIGURE II-4 shows a stop valve ahead of a relief valve. This stop valve is required to allow for system maintenance and testing. However, there can be serious consequences if it is closed during an emergency because this would cut the relief valve out of the pipeline system. Closure could be an innocent act or it could be malicious. Nonetheless, certain cautions are essential. Only authorized personnel may use the stop valve. Likewise, it must be adequately protected against unauthorized closure. Most important, it should be locked in an open position.

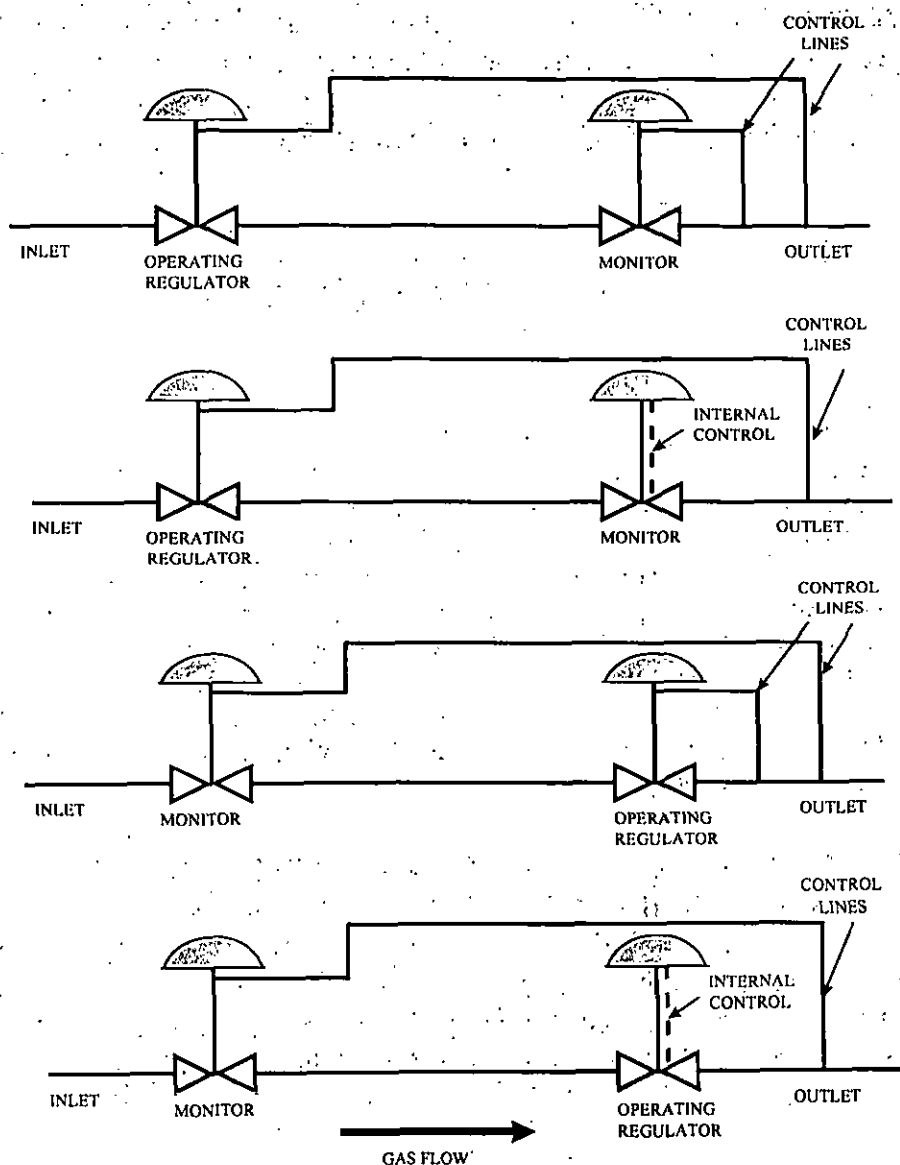
## MONITORING

This section deals with the most widely used form of monitoring, standby or passive monitoring. FIGURE II-5 shows standby monitoring in four basic arrangements using regulators with control lines and with internal control. Note the following:

- Either the upstream or the downstream regulator can be the monitor.
- The downstream regulator can have either a control line or internal control.

The upstream regulator must have a control line.

FIGURE II-5 STANDBY MONITORING



Standby monitoring is sometimes confused with two-stage or double-cut regulation. The big difference is in the control line for the upstream regulator. In standby monitoring, the control line for the upstream regulator goes all the way downstream. It does not connect between the regulators as in two-stage regulation. To repeat, the control line for the upstream regulator in standby monitoring goes on beyond the downstream regulator to a point somewhere in the outlet piping. That is the reason the upstream regulator in standby monitoring must have a control line, whereas in two-stage regulation the upstream, as well as the downstream, regulator can have either a control line or internal control:

Two-stage regulation can be used as a form of monitoring provided the following conditions are met:

- The system downstream of the second stage regulator (including the regulator) must have an MAOP equal to or greater than the outlet pressure of the first stage regulator.
- The second stage regulator must be rated for an inlet pressure as high as the maximum inlet pressure of the first stage regulator, and the diaphragm case of the first stage regulator must be able to safely withstand this maximum inlet pressure.

As shown in FIGURE II-5, the set point for the operating regulator is the normal outlet pressure, that is, the pressure normally required for the load.

The set point for the monitor is higher. Because it is higher, the monitor is further open than the operating regulator (usually the monitor is wide open) and allows the gas to flow normally.

If the operating regulator "fails-open" the outlet pressure will rise. It will rise until the pressure reaches the set point of the monitor. Then, the monitor will become the operating regulator and will hold outlet pressure at its set point.

The monitor set point, of course, must not exceed the MAOP of the downstream piping system. The difference between the set points of the monitor and the operating regulator is not critical. However, the two should not be so close as to cause the monitor to interfere with the operating regulator. Other than this, monitor set point is largely determined by the requirements of the installation and applicable practices and standards.

#### AUTOMATIC SHUTOFF

In an automatic shutoff installation, a special valve is used to shut off the gas completely if pressure reaches a preset level. During normal operation the valve remains fully open and allows gas to flow freely.

If a regulator failure ("fail-open") or another factor causes outlet pressure to rise, the automatic shutoff valve closes when pressure reaches its set point.

The normal outlet pressure is the regulator's set point. The set point of the automatic shutoff valve will, of course, be higher. How much higher must be decided when planning and

engineering the installation. It must not exceed the MAOP (the maximum safe limit) of the downstream piping.

Automatic shutoff valves close automatically, but must be manually reset. This has the advantage of preventing an emergency from passing unnoticed.

Shutting the gas off at times of emergency is imperative. However, in the natural gas business, continuity of service is also important. This is probably why automatic shutoff has found only limited use in the gas industry. Pressure relief and monitoring are preferred because they offer full protection while allowing a safe flow of gas to continue.

Automatic shutoff valves are available with control line or with internal control. Both are shown in FIGURE II-6.

### **Control Line**

Because an automatic shutoff valve with a control line is located upstream of the regulator, the foregoing hazards from exposure to inlet pressure are eliminated. The entire regulator, as well as everything downstream, is isolated from exposure to inlet pressure.

Care should be used in installing the control line. It should be strong, and be protected and routed to minimize any possibility of breakage. If broken, the automatic shutoff valve becomes inoperative. If an emergency occurs, it will not close, as it should.

Some automatic shutoff valves are available with a temperature option. They close not only from excess pressure, but also excess temperature. If properly located, they can help in case of fire. Automatic shutoff is also available for closure in case of underpressuring (a "failed-closed" regulator failure).

Relief valves, monitors, and automatic shutoff valves are all effective, dependable devices for protection against the hazard of excess pressure. However, to be sure of this protection, they must be correctly engineered, installed, and maintained. They must be used in conformance with manufacturer's ratings and recommendations. Whenever any doubts or questions arise, it is always a good idea to ask the manufacturer.

### **Internal Control**

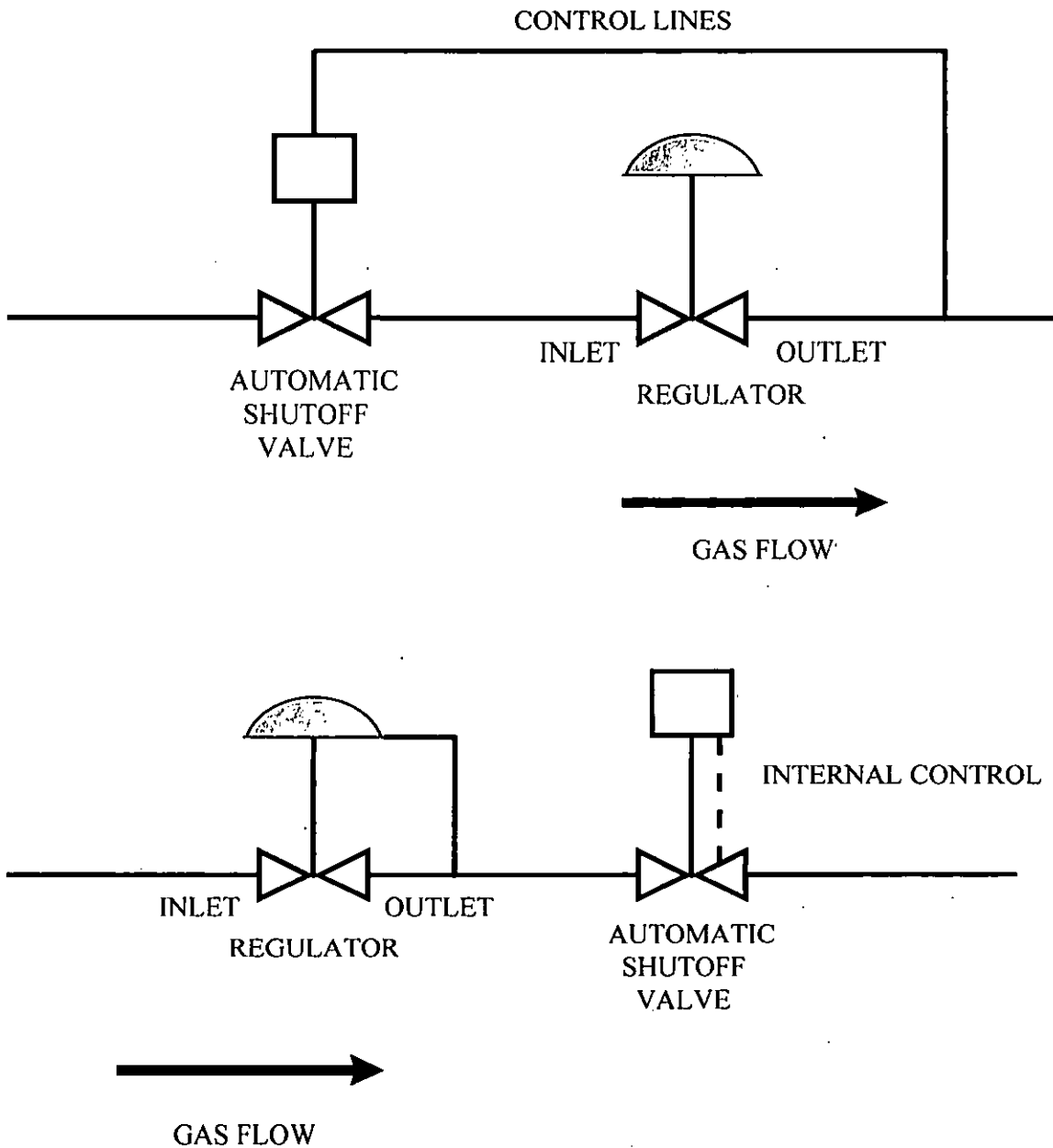
This offers a simpler installation because there is no control line. However, due to its internal control, it must be located downstream of the regulator. Therefore, upon closure, everything upstream of the shutoff valve will be pressured to full inlet pressure.

This means that if the regulator has internal control, its main diaphragm will be exposed to full inlet pressure. This could result in severe damage, even to the extent of a burst regulator. The same applies to a regulator with a control line if the control line is connected (the sensing point) between the regulator and the automatic shutoff valve. If an automatic shutoff valve with

internal control is used, everything between it and the regulator, including the regulator itself, must be carefully checked for exposure to full maximum inlet pressure.

Moreover, if the piping for the regulator is larger than the inlet piping, an internal control type automatic shutoff valve will need to be a larger size than one with a control line.

FIGURE II-6 AUTOMATIC SHUTOFF VALVE INSTALLATIONS



## CHAPTER III

### CORROSION CONTROL

#### FEDERAL REQUIREMENTS

This chapter contains a simplified description of the corrosion control requirements contained in the pipeline safety regulations. The complete text of the corrosion control requirements can be found in 49 CFR Part 192.

#### **Procedures and Qualifications**

Operators must establish procedures to implement and maintain a corrosion control program for their piping system. These procedures should include design, installation, operation, and maintenance activities on a cathodic protection system. A person qualified in pipeline corrosion control methods must carry out these procedures.

#### **Techniques for Compliance**

The following is a list of sources where operators of small natural gas systems can find qualified personnel to develop and carry out a corrosion control program:

- There are many consultants and experts who specialize in cathodic protection. Many advertise in gas trade journals.
- Another source, especially for master meter operators, is an experienced corrosion engineer or technician working for a local gas utility company. Such experts may be able to implement cathodic protection for small operators, or refer them to local qualified corrosion engineers.
- Operators of small municipal systems can contact the transmission company that supplies their gas. A municipal corrosion engineer or technician may be able to supply information as to where to find local qualified corrosion engineers.
- OPS suggests that operators of small natural gas systems encourage their respective trade associations (such as state and local mobile home associations or municipal associations) to gather and maintain records of available consultants or contractors who are qualified in their specific region.
- The local chapter of "NACE International" (National Association of Corrosion Engineers) may be able to provide useful information.
- Operators who are unsure of a consultant's qualification in corrosion control should contact operators who have hired the consultant in the past.

## **Corrosion Control Requirements for Pipelines Installed After July 31, 1971**

All buried metallic pipe installed after July 31, 1971, must be properly coated and have a cathodic protection system designed to protect the pipe in its entirety.

Newly constructed metallic pipelines must be coated before installation and must have a cathodic protection system installed and placed in operation in its entirety within one year after construction of the pipeline. However, the operator must make tests no later than six months after installation to demonstrate that no corrosion control measures are necessary. If tests indicate that corrosion control is necessary, the pipeline must be cathodically protected.

OPS recommends that all operators of small natural gas systems coat and cathodically protect all new metallic pipe. It is extremely difficult and costly to prove that a noncorrosive environment exists.

Cathodic protection requirements do not apply to electrically isolated, metal alloy fittings in plastic pipelines if the alloyage of the fitting provides corrosion control, and if corrosion pitting will not cause leakage.

## **Corrosion Control Requirements for Pipelines Installed Before August 1, 1971**

For Pipelines installed before August 1, 1971, (bare pipe or coated pipe), must be cathodically protected in areas that are determined to be active corrosion. All underground natural gas distribution systems, including underground piping related to regulating and measuring stations, must be cathodically protected in areas of active corrosion.

The operator must determine areas of active corrosion by (a) electrical survey, (b) where electrical survey is impractical, by the study of corrosion and leak history records, or (c) by leak detection surveys.

Active corrosion means continuing corrosion, which, unless controlled, could result in a condition that is detrimental to public safety.

As a guideline for operators when determining corrosion to be detrimental to public safety (active corrosion), OPS recommends the following:

- For master meter operators, all continuing corrosion occurring on metallic pipes (other than cast iron or ductile iron pipes) should be considered active and pipes should be cathodically protected, repaired, or replaced.
- For operators of small municipal gas systems, all continuing corrosion occurring on the distribution system in city limits (within 100 yards of a building intended for human occupancy, regulator stations, and at highway and railroad crossings) should be considered active and pipes should be cathodically protected, repaired, or replaced. Need to clarify what's needed.

- OPS recommends that operators of small gas systems and their consultants use these following guidelines in determining where it is impractical to do electrical surveys to find areas of active corrosion:
  - a. Where the pipeline is more than 2 feet from the edge of a paved street or within wall to wall pavement areas.
  - b. Pipelines in a common trench with other metallic structures.

Electrical surveys may prove to be impractical due to conditions other than those listed above. The operator must demonstrate the impracticability of an electrical survey.

In areas where electrical surveys cannot be run to determine corrosion, the operator should run leakage surveys on a more frequent basis. OPS recommends that these surveys be run at least once a year.

Electrical surveys to find active corrosion must be run by a person qualified in pipeline corrosion control methods.

### **Coating Requirements**

All metallic pipe installed below ground, as a new or replacement pipeline system, should be coated in its entirety (APPENDIX B, FORM 1). Types of coatings and handling practices are discussed later in this chapter.

### **Examination of Exposed Pipe**

Whenever buried pipe is exposed or dug up, the operator is required to examine the exposed portion of the pipe for evidence of corrosion on bare pipe or for deterioration of the coating on coated pipe. A record of this examination must be maintained. If the coating has deteriorated or the bare pipe has evidence of corrosion, remedial action must be taken (APPENDIX B, FORM 1).

### **Criteria for Cathodic Protection**

Operators must meet one of five criteria listed in Appendix D of 49 CFR Part 192, to comply with the pipeline safety regulations for cathodic protection.

The criteria that most operators of small natural gas systems will choose to meet will be a (cathodic) voltage of at least -0.85 volt with reference to a saturated copper-copper sulphate half-cell (Appendix B, Form 14). NOTE: IR drop must be considered.

### **Monitoring**

A piping system that is under cathodic protection must be systematically monitored. Tests for effectiveness of cathodic protection must be done at least once every year. Records of this monitoring must be maintained (APPENDIX B, FORM 14).

Short, separately protected service lines or short, protected mains may be surveyed on a sampling basis. At least 10 percent of these short sections and services must be checked each year so that all short sections in the system are tested in a 10-year period. Examples of short, separately protected pipe in a small natural gas system would be:

- Steel service lines connected to, but electrically isolated from, cast iron mains.
- Steel service risers that have cathodic protection provided by an anode attached to a riser that is installed on plastic service lines.

OPS recommends, if a small number of isolated protection sections of pipeline exist in the system, that the operator include all sections in the annual survey.

When using rectifiers to provide cathodic protection, each rectifier must be inspected six times every year. The intervals must not exceed 2½ months, to ensure that the rectifier(s) is properly operating. Records must be maintained (APPENDIX B, FORM 15).

Operators must take prompt action to correct any deficiencies indicated by the monitoring.

### **Electrical Isolation**

Pipelines must be electrically isolated from other underground metallic structures (unless electrically interconnected and cathodically protected as a single unit). For illustrations of where meter sets are commonly electrically insulated, see FIGURES 8, 13, and 14 in this chapter.

### **Test Points**

Each pipeline under cathodic protection must have sufficient test points for electrical measurement to determine the adequacy of cathodic protection. Test points should be shown on a cathodic protection system map.

### **Internal Corrosion Inspection**

Whenever a section of pipe is removed from the system, the internal surface must be inspected for evidence of corrosion. Remedial steps must be taken if internal corrosion is found. Be sure to keep records of this inspection (APPENDIX B, FORM 1).

## **Atmospheric Corrosion**

Newly installed above ground pipelines must be cleaned and coated or jacketed with a material suitable for the prevention of atmospheric corrosion. Above ground pipe, including meters, regulators, and measuring stations, must be inspected for atmospheric corrosion once every year. Remedial action must be taken if atmospheric corrosion is found (APPENDIX B, FORM 13).

## **Remedial Measures**

All steel pipe used to replace an existing pipe must be coated and cathodically protected. Each segment of pipe that is repaired because of corrosion leaks must be cathodically protected.

## **Graphitization of Cast Iron**

Graphitization is the process by which the cast iron pipe corrodes, leaving a brittle sponge-like structure of graphite flakes. There may be no appearance of damage, but the affected area of the pipe becomes brittle. For example, a completely graphitized buried cast iron pipe may hold gas under pressure but will fracture under a minor impact, such as being hit by a workman's shovel. Cast iron is a metallurgical combination of iron and carbon (graphite).

Each segment of cast iron or ductile iron pipe with Graphitization (to a degree where a fracture or any leakage might result) must be replaced.

## **Records**

Operators must maintain records or maps of their cathodic protection system. Records of all tests, surveys, or inspections required by the pipeline safety code must be maintained. See APPENDIX B for samples of records/forms.

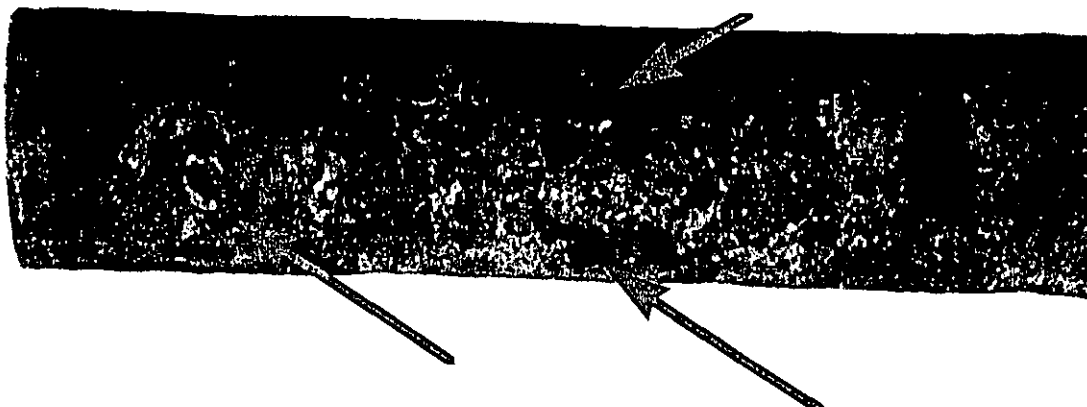
## **PRINCIPLES AND PRACTICES OF CATHODIC PROTECTION**

This section gives operators with little or no experience in cathodic protection, a review of the general principles and practices of cathodic protection. Common causes of corrosion, types of pipe coatings, and criteria for cathodic protection are among the topics. A checklist of steps which an operator of a small natural gas system may use to determine the need for cathodic protection is included. Basic definitions and illustrations are used to clarify the subject. This section does not go into great depth. Therefore, reading this section alone will not qualify an operator to design and implement cathodic protection systems.

## **Basic Terms**

**Corrosion** is the deterioration of metal pipe. Corrosion is caused by a reaction between the metallic pipe and its surroundings. As a result, the pipe deteriorates and may eventually leak. Although corrosion cannot be eliminated, it can be substantially reduced with cathodic protection (see FIGURE III-1).

FIGURE III-1 BARE PIPE - NOT UNDER CATHODIC PROTECTION

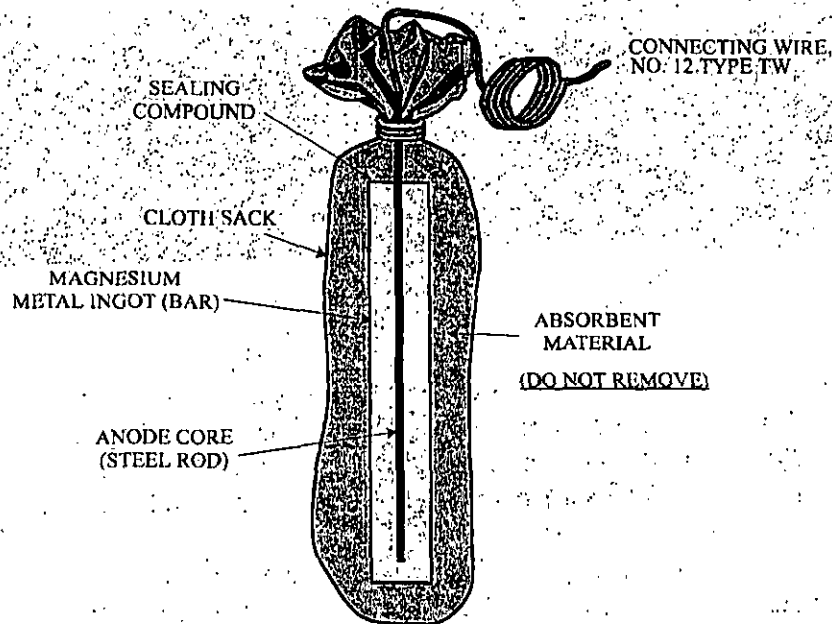


An example of bare steel pipe installed for gas service. Note the deep corrosion pits that have formed. Operators should never install bare steel pipe underground. Operators should use either polyethylene pipe manufactured according to ASTM D2513 or coated steel pipe as new or replacement pipe. If steel pipe is installed, that pipe must be coated and cathodically protected.

**Cathodic protection** is a procedure by which an underground metallic pipe is protected against corrosion. A direct current is impressed onto the pipe by means of a sacrificial anode or a rectifier. Corrosion will be reduced where sufficient current flows onto the pipe.

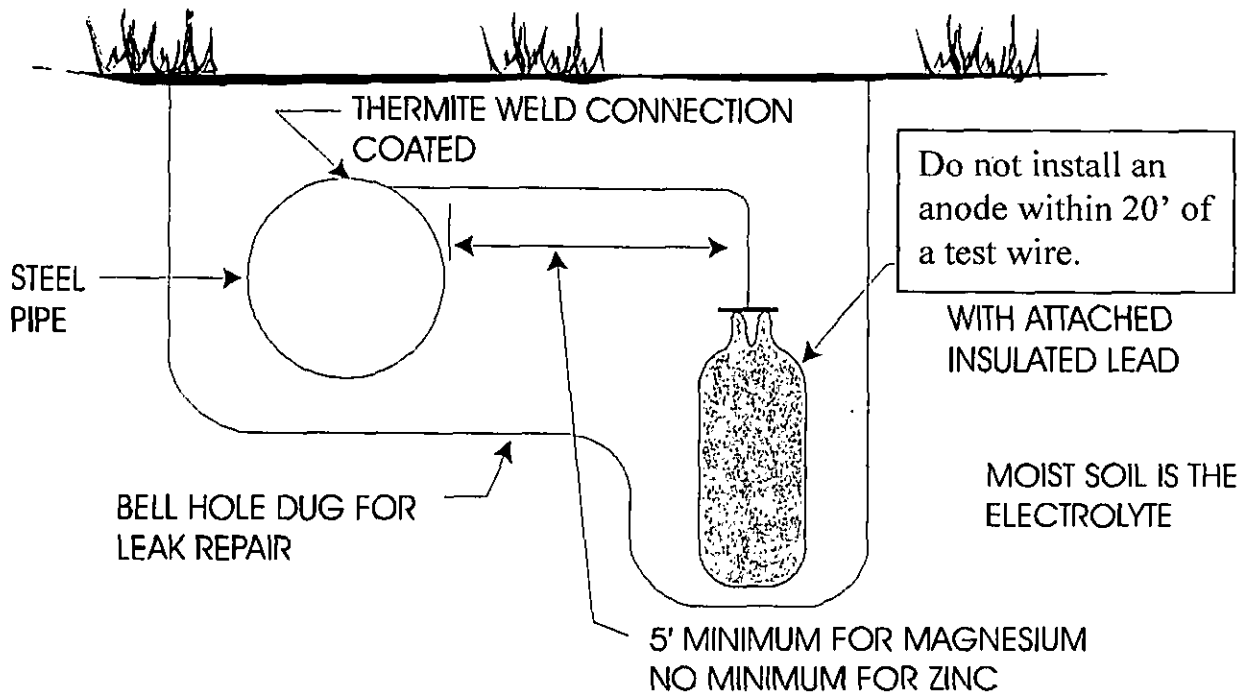
**Anode (sacrificial)** is an assembly consisting of a bag usually containing a magnesium or zinc ingot and other chemicals, which is connected by wire to an underground metal piping system. It functions as a battery that impresses a direct current on the piping system to retard corrosion (see FIGURE III-2).

**FIGURE III-2 TYPICAL MAGNESIUM (MG) ANODE**



**Sacrificial protection** means the reduction of corrosion of a metal (usually steel in a gas system) in an electrolyte (soil) by galvanically coupling the metal (steel) to a more anodic metal (magnesium or zinc) (see FIGURE III-3). The magnesium or zinc will sacrifice itself (corrode) to retard corrosion in steel the pipe.

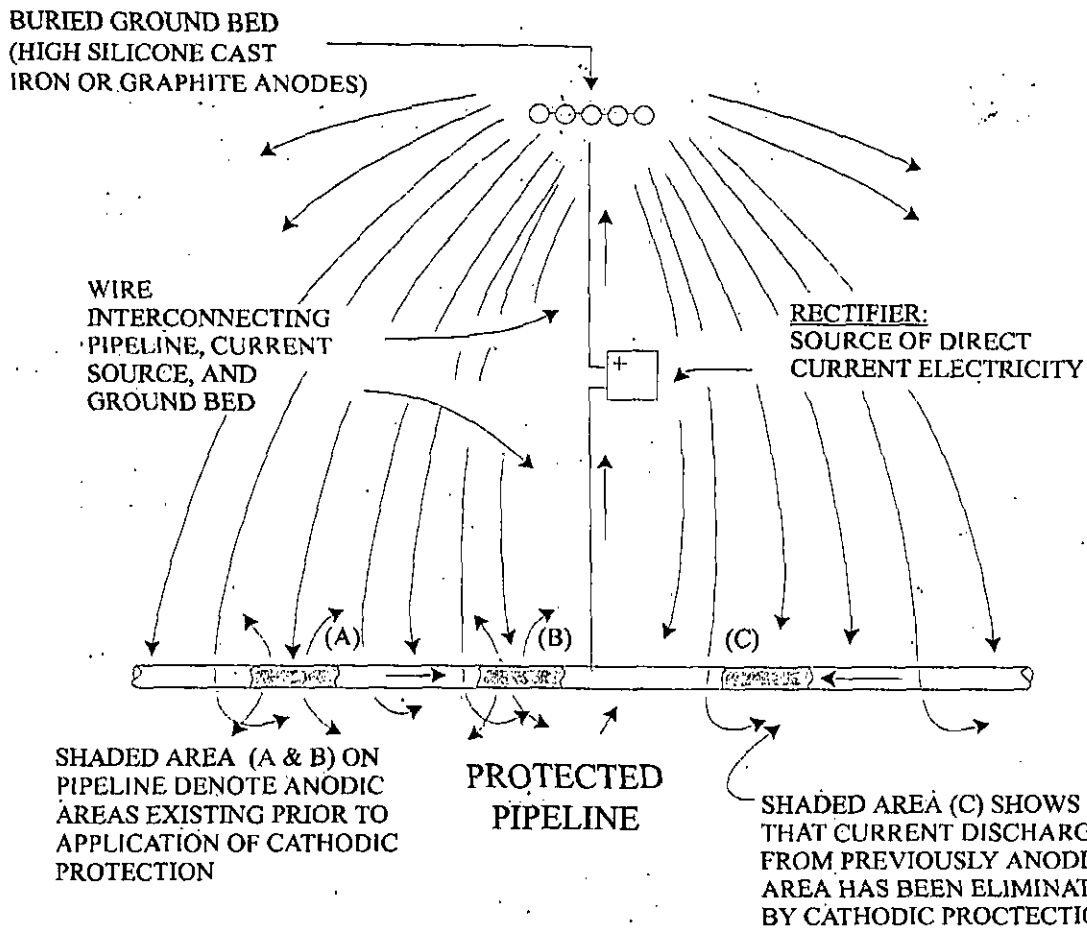
FIGURE III-3



Zinc and magnesium are more anodic than steel. Therefore, they will corrode to provide cathodic protection for steel pipe.

**Rectifier** is an electrical device that changes alternating current (a.c.) into direct current (d.c.). This current is then impressed on an underground metallic piping system to protect it against corrosion (see FIGURE III-4).

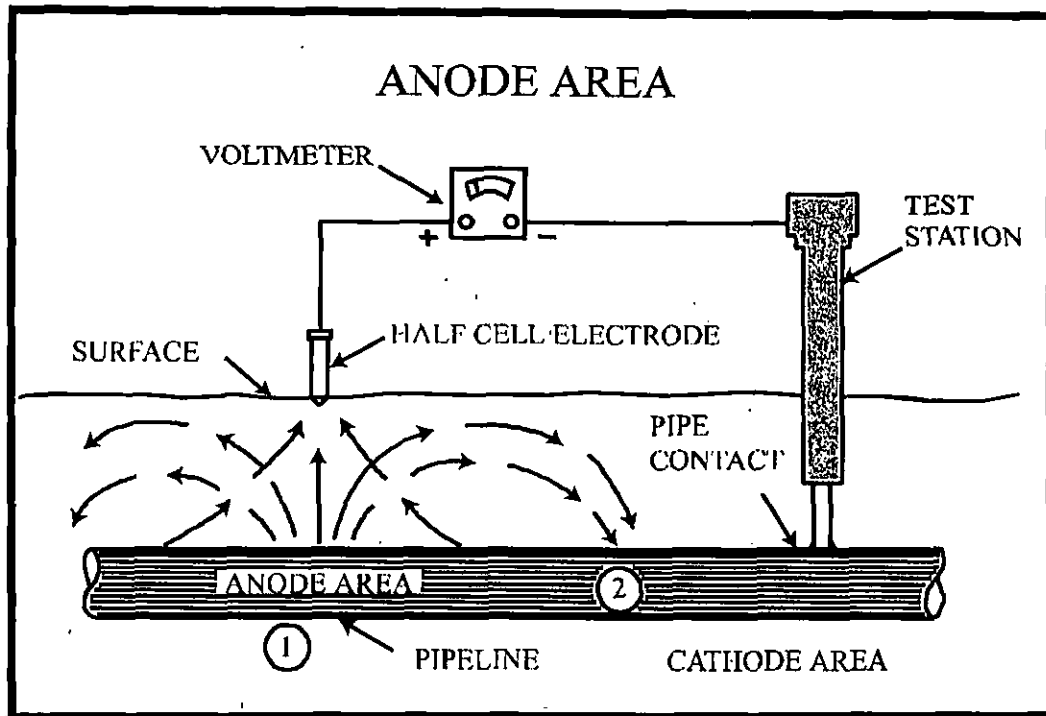
FIGURE III-4



This illustrates how cathodic protection can be achieved by use of a rectifier. Make certain the negative terminal of the rectifier is connected to the pipe. **NOTE:** If the reverse occurs (positive terminal to pipe), the pipe will corrode much faster.

**Potential** means the difference in voltage between two points of measurement (see FIGURE III-5).

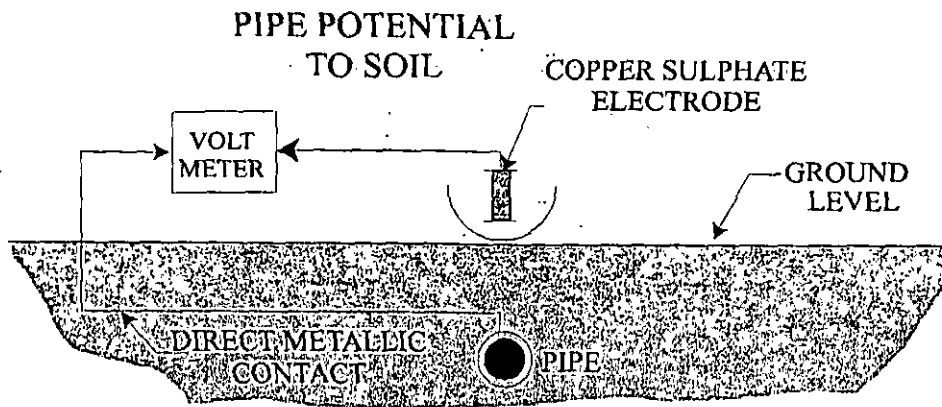
FIGURE III-5



The voltage potential in this example is the difference between points 1 and 2. Therefore, the current flow is from the anodic area (1) of the pipe to the cathodic area (2). The half-cell is an electrode made up of copper immersed in copper-copper sulphate ( $\text{Cu-CuSO}_4$ ).

**Pipe-to-soil potential** is the potential difference (voltage reading) between a buried metallic structure (piping system) and the soil surface. The difference is measured with a half-cell reference electrode (see definition of reference electrode that follows) in contact with the soil (see FIGURE III-6).

FIGURE III-6



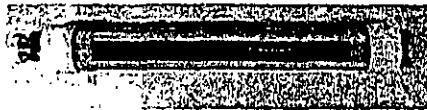
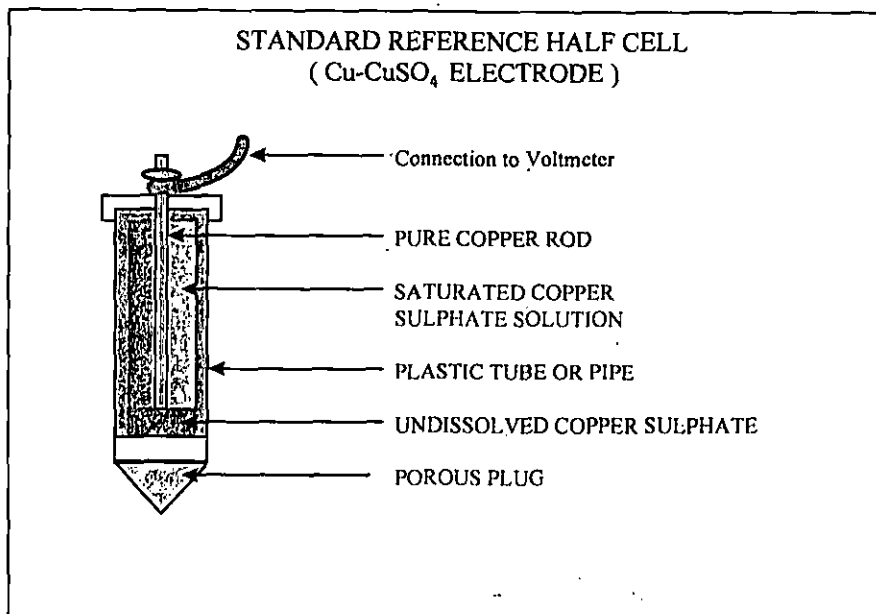
1. INVESTIGATE CORROSIVE CONDITIONS.
2. EVALUATE THE EXTENT OF CATHODIC PROTECTION

If the voltmeter reads at least  $-0.85$  volt, the operator can usually consider that the steel pipe has cathodic protection. **NOTE:** Be sure to take into consideration the voltage (IR) drop that is the difference between the voltage at the top of the pipe and the voltage at the surface of the earth.

**Reference electrode (commonly called a half-cell)** is a device which usually has copper immersed in a copper sulphate solution. The open circuit potential is constant under similar conditions of measurement (see FIGURE III-7).

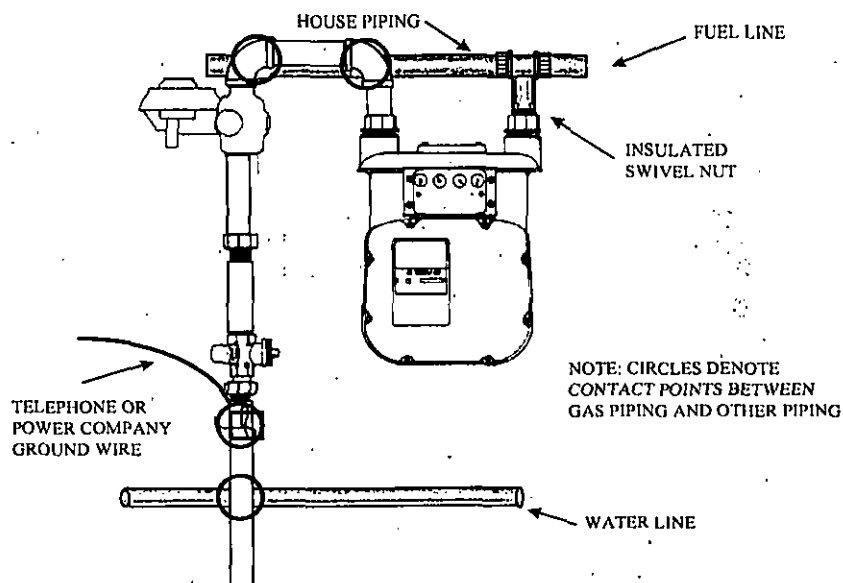
FIGURE III-7 REFERENCE ELECTRODE – A SATURATED COPPER-COPPER SULPHATE HALF-CELL.

(Caution Copper-Copper Sulphate is Poisonous)



**Short or corrosion fault** means an accidental or incidental contact between a cathodically protected section of a piping system and other metallic structures (water pipes, buried tanks, or unprotected section of a gas piping system) (see FIGURE III-8).

**FIGURE III-8 TYPICAL METER INSTALLATION ACCIDENTAL CONTACTS**  
(Meter Insulator Shorted Out by House Piping, etc.)



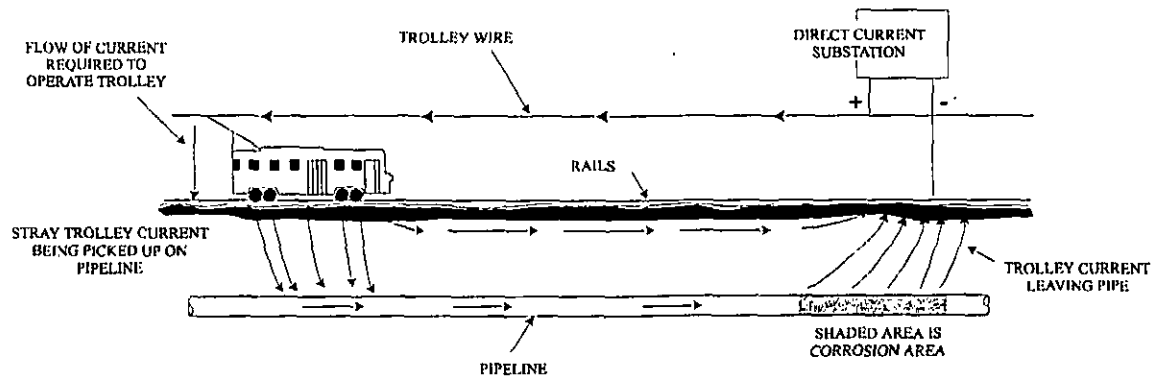
Unshaded piping shows Operators piping from service entry to meter insulator at location shown on sketch above. Shaded areas show house piping, electrical cables, etc.

The circled locations are typical points where the Operators piping (unshaded) can come in metallic contact with house piping. This causes shorting out or "bypassing" of the meter insulator.

The only way to clear these contacts permanently is to move the piping that is in contact. (The use of wedges, etc., to separate the piping is not acceptable). If the above ground piping cannot be moved, install a new insulator between the accidental contact and the service entry.

**Stray current** means current flowing through paths other than the intended circuit (see FIGURE III-9). If your pipe-to-soil readings fluctuate, stray current may be present.

FIGURE III-9



This drawing illustrates an example of stray d.c. current getting onto a pipeline from an outside source. This can cause severe corrosion in the area where the current eventually leaves the pipe. Expert help is needed to correct this type of problem.

**Stray current corrosion** means metal destruction or deterioration caused primarily by stray d.c. affecting the pipeline.

**Galvanic series** is a list of metals and alloys arranged according to their relative potentials in a given environment.

**Galvanic corrosion** occurs when any two of the metals in TABLE I (next page) are connected in an electrolyte (soil). Galvanic corrosion is caused by the different potentials of the two metals.

**TABLE 1**

<u>METAL</u>	<u>Potentials</u> <u>VOLTS*</u>	
Commercially pure magnesium	-1.75	
Magnesium alloy (6% Al, 3% Zn, 0.15% Mn)	-1.6	
Zinc	-1.1	
Aluminum alloy (5% zinc)	-1.05	
Commercially pure aluminum	-0.8	
Mild steel (clean and shiny)	-0.5 to -0.8	
Mild steel (rusty)	-0.2 to -0.5	
Cast iron (not graphitized)	-0.5	
Lead	-0.5	
Mild steel in concrete	-0.2	
Copper, brass, bronze	-0.2	
High silicon cast iron	-0.2	
Mill scale on steel	-0.2	
Carbon, graphite, coke	+0.3	

\* Typical potential in natural soils and water, measured with respect to a copper-copper sulphate reference electrode.

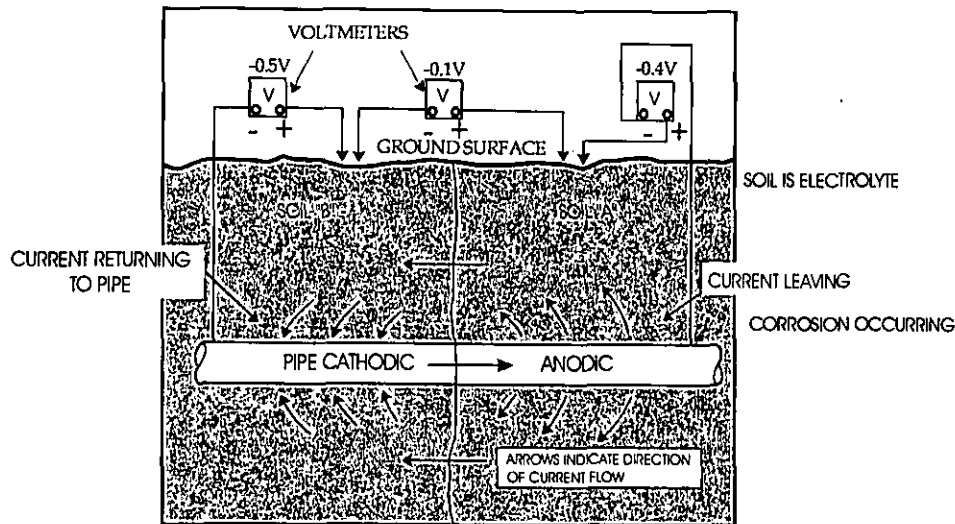
When electrically connected in an electrolyte, any metal in the table will be anodic (corrode relative to) to any metal below it. That is, the more anodic metal sacrifices itself to protect the metal (pipe) lower in the table.)

**FUNDAMENTAL CORROSION THEORY**

In order for corrosion to occur there must be four parts: An electrolyte, anode, cathode, and a metallic return path. A metal will corrode at the point where current leaves the anode (see FIGURE III-10). NOTE: Dissimilar soils may create an environment that enhances corrosion.

FIGURE III-10

A corrosion cell may be described as follows:



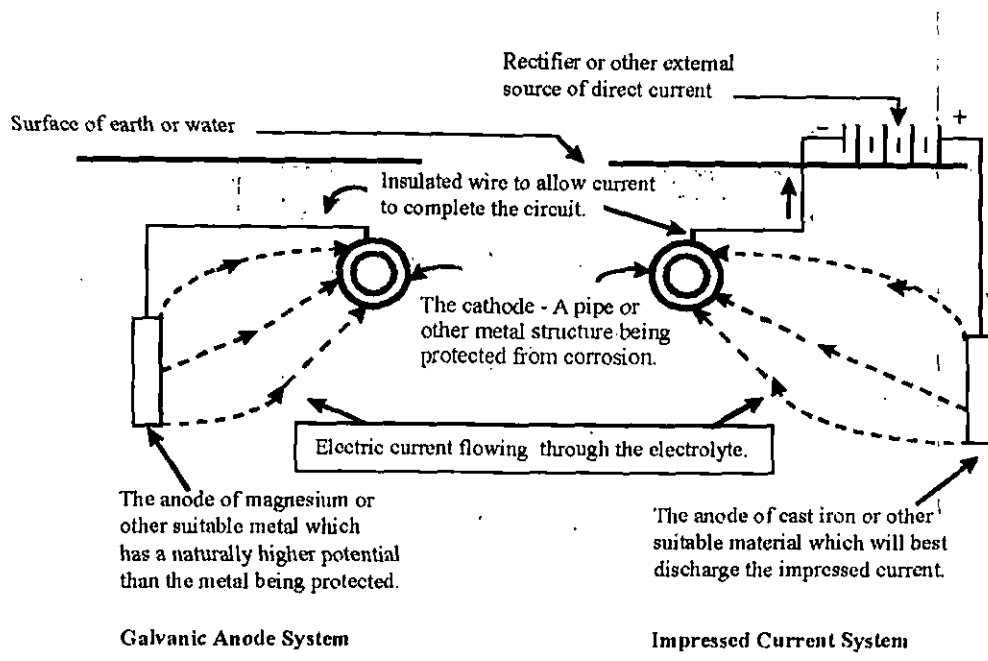
- Current flows through the electrolyte from the anode to the cathode. It returns to the anode through the return circuit.
- Corrosion occurs whenever current leaves the metal (pipe, fitting, etc.) and enters the soil (electrolyte). The area where current leaves is said to be anodic. Corrosion, therefore, occurs in the anodic area.
- Current is picked up at the cathode. No corrosion occurs here. The cathode is protected against corrosion. Polarization (hydrogen film buildup) occurs at the cathode. When the film of hydrogen remains on the cathode surface, it acts as an insulator and reduces the corrosion current flow.
- The flow of current is caused by a potential (voltage) difference between the anode and the cathode.

### TYPES OF CATHODIC PROTECTION

There are two basic methods of cathodic protection: the galvanic anode system and the impressed current system.

Galvanic anodes are commonly used to provide cathodic protection on gas distribution systems. Impressed current systems are normally used for transmission lines. However, if properly designed, impressed current can be used on a distribution system (see FIGURE III-11).

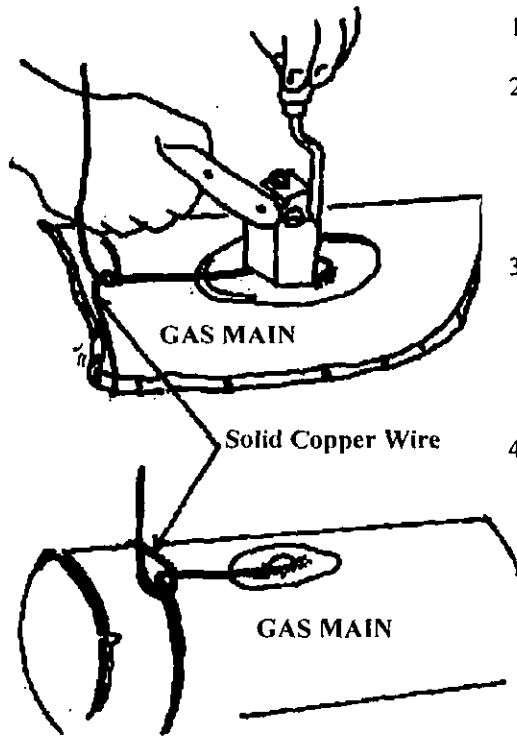
FIGURE III-11



Any current, whether galvanic or stray, that leaves the pipeline causes corrosion. In general, corrosion control is obtained as follows:

**Galvanic Anode System.** Anodes are "sized" to meet current requirements of the resistivity of the environment (soil). The surface area of the buried steel and estimated anode life determines the size and number of anodes required. Anodes are made of materials such as magnesium (Mg), zinc (Zn), or aluminum (Al). They are usually installed near the pipe and connected to the pipe with an insulated conductor. They are sacrificed (corroded) instead of the pipe (see FIGURES III-3, III-11, AND III-12).

FIGURE III-12 TYPICAL PROCEDURE FOR INSTALLING A MAGNESIUM ANODE BY THE THERMO-WELD PROCESS



1. Loop wire as shown to avoid strain on bond.
2. Insert conductor in mold-do not push end of conductor past center of tap hole. Drop metal disc over tap hole. Remove all starting power from cartridge by tapping the inverted cartridge on lip of mold.
3. Close cover, hold mold steady. Ignite starting power with flint gun as shown. When powder fires, remove gun immediately. Hold mold steady for 10 seconds. Remove slag from weld.
4. See the manufacturer's recommendation before proceeding.

After welding, all exposed pipe should be well coated and wrapped.

Impressed Current Systems. Anodes are connected to a direct current source, such as a rectifier or generator. These systems are normally used along transmission pipelines where there is less likelihood of interference with other pipelines. The principle is the same except that the anodes are made of materials such as graphite, high silicon cast iron, lead-silver alloy, platinum, or scrap steel.

INITIAL STEPS IN DETERMINING THE NEED TO CATHODICALLY PROTECT A SMALL GAS DISTRIBUTION SYSTEM

1. Determine type(s) of pipe in system: bare steel, coated steel, cast iron, plastic, galvanized steel, ductile iron, or other.
2. Date gas system was installed:  
Year pipe was installed (steel pipe installed after July 1, 1971, must be cathodically protected in its entirety).

Who installed pipe? By contacting the contractor and other operators who had pipe installed by same contractor, operators may be able to obtain valuable information, such as:

- Type of pipe in ground.
  - If pipe is electrically isolated.
  - If gas pipe is in common trench with other utilities.
3. Pipe location - map/drawing. Locate old construction drawings or current system maps. If drawings are unavailable, a metallic pipe locator may be used.
  4. Before the corrosion engineer arrives, it is a good idea to make sure that customer meters are electrically insulated. If system has no meter, check to see if gas pipe is electrically insulated from house or mobile home pipe (see FIGURE III-13).
  5. Contact an experienced corrosion engineer or consulting firm. Try to complete steps 1 through 4 before contracting a consultant.

#### 6. Use of Consultant

A sample method, which may be used by a consultant to determine cathodic protection needs, is provided below:

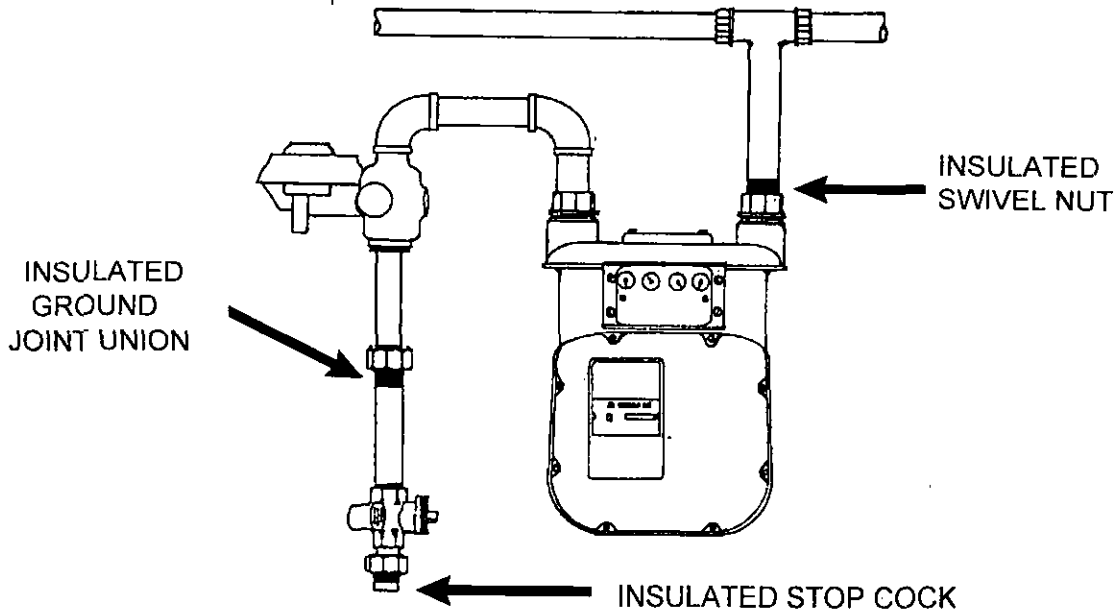
- An initial pipe-to-soil reading will be taken to determine whether the system is under cathodic protection.
- If the system is not under cathodic protection, the consultant should clear underground shorts or any missed meter shorts. (The consultant will probably use a tone test.)
- After the shorts are cleared, another pipe-to-soil test should be taken. If the system is not under cathodic protection, a current requirement test should be run to determine how much electrical current is needed to protect the system.
- Additional tests, such as a soil resistivity test, bar hole examination, and other electrical tests, may be needed. The types of tests needed will vary for each gas system.

Remember to retain copies of all tests run by the corrosion engineer.

#### 7. Cathodic Protection Design

The experienced corrosion engineer or gas consultant, will design a cathodic protection system based on the results of testing, that best suits the gas piping system.

FIGURE III-13



Places where a meter installation may be electrically isolated.

FIGURE III-14

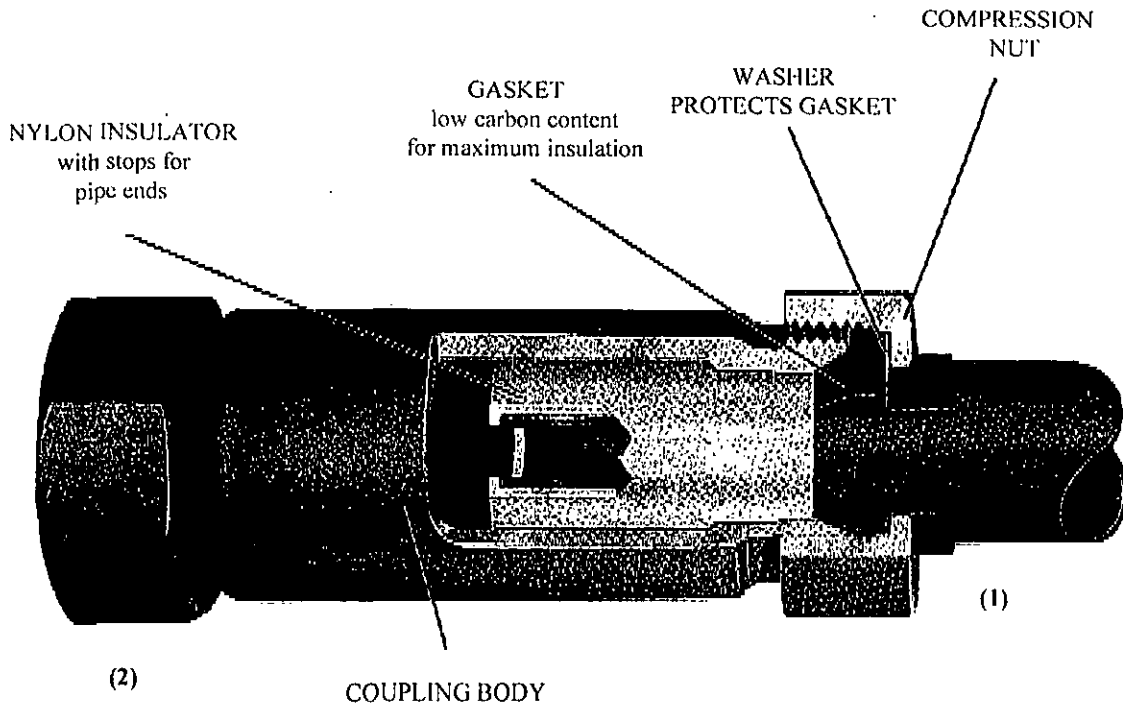
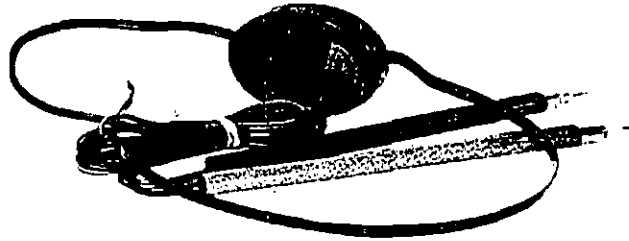


Illustration of an insulated compression coupling used on meter sets to protect against corrosion. Pipe connection by this union will be electrically insulated between the piping located on side one (1) and the piping located on side two (2).

FIGURE III-15



INSULATION TESTER

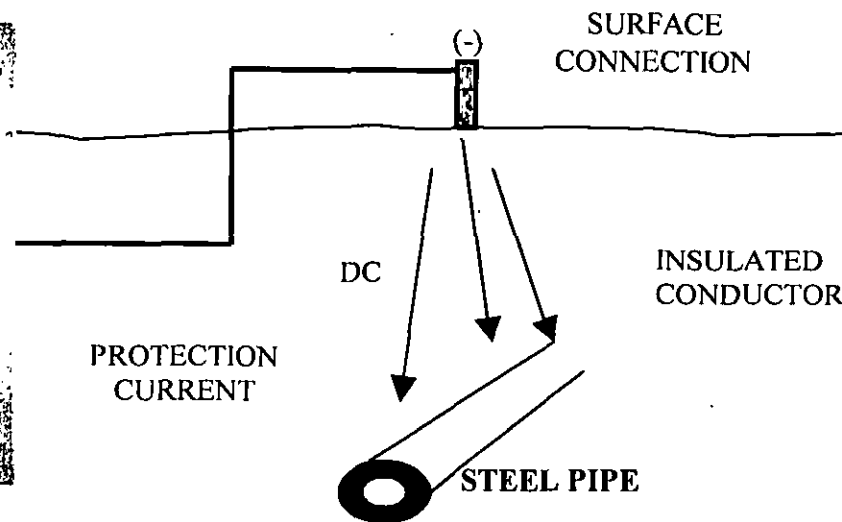
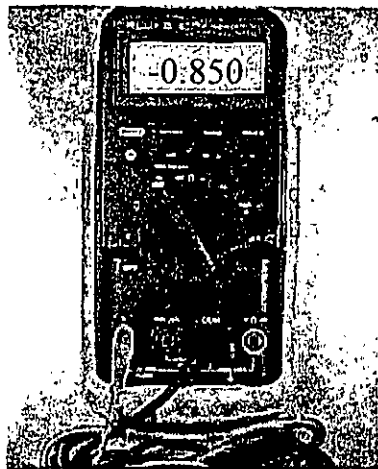
This insulation tester consists of a magnetic transducer mounted in a single earphone headset with connecting needlepoint contact probes. It is a "go" or "no go" type tester which operates from low voltage current present on all underground piping systems thus eliminating the necessity of outside power sources or costly instrumentation and complex connections. By placing the test probes on the metallic surface on either side of the insulator a distinct audible tone will be heard if the insulator is performing properly. Absence of audible tone indicates faulty insulator. Insulator effectiveness can be determined quickly using this simple, easy-to-operate tester.

CRITERIA FOR CATHODIC PROTECTION

There are five criteria listed in Appendix D of Part 192, to qualify a pipeline as being cathodic protected. Operators can meet the requirements of any one of the five to be in compliance with the pipeline safety regulations. Most systems will be designed to Criterion 1.

Criterion 1: With the protective current applied, a voltage of at least -0.85 volt measured between the pipeline and a saturated copper-copper sulfate half-cell. This measurement is called the pipe-to-soil potential reading (see FIGURE III-16).

FIGURE III-16 PIPE-TO-SOIL POTENTIAL READING.



This is a pipe-to-soil voltage meter with reference cell attached. This is a simple meter to use and is excellent for simple "go-no-go" type monitoring of a cathodic protection system. If meter reaches at least -0.85 volt, the operator knows that the steel pipe is under cathodic protection. If not, remedial action must be taken promptly. **NOTE:** Be sure to take into consideration the voltage drop.

## COATINGS

There are many different types of coating on the market. The better the coating application, the less electrical current is needed to cathodically protect the pipe.

### **Mill Coated Pipe**

When purchasing steel pipe for underground gas services, operators should purchase mill coated pipe (i.e., pipe coated during manufacturing process). Some examples of mill coatings are:

- Extruded polyethylene or polypropylene plastic coatings,
- Coal tar coatings,
- Enamels,
- Mastics,
- Epoxy.

A qualified (corrosion) person can help select the best coating for a natural gas system. A local natural gas utility may be able to give master meter operators the name and location of nearby suppliers of mill coated gas pipe. When purchasing steel pipe, remember to verify that the pipe was manufactured according to one of the specifications listed in Chapter VI of this manual. This can be verified by a bill of lading or by the markings on mill coated pipe.

### **Patching**

Tape material is a good choice for external repair of mill coated pipe. Tape material is also a good coating for both welded and mechanical joints made in the field. Some tapes in use today are:

- PE and PVC tapes with self-adhesive backing applied to a primed pipe surface,
- Plastic films with butyl rubber backing applied to a primed surface,
- Plastic films with various bituminous backings.

Consult a pipe supplier before purchasing tapes. Tapes must be compatible with the mill coating on the pipe.

## Coating Application Procedures

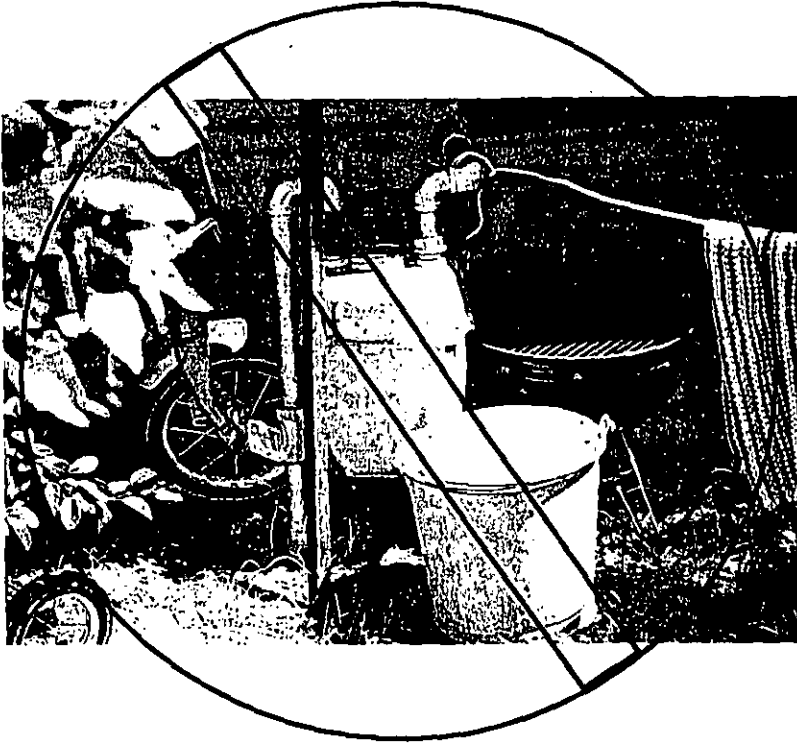
When repairing and installing metal pipe, be sure to coat bare pipes, fittings, etc. It is absolutely essential that the instructions (supplied by the manufacturer of the coating) be followed precisely. Time and money is wasted if the instructions are not followed.

Some general guidelines for installation of pipe coatings:

- Properly clean pipe surface (remove soil, oil, grease, and any moisture),
- Use careful priming techniques (avoid moisture; follow manufacturer's recommendations),
- Properly apply the coating materials (be sure pipe surface is dry - follow manufacturer's recommendations). Make sure soil or other foreign material does not get under coating during installation,
- Only backfill with material that is free of objects capable of damaging the coating. Severe coating damage can be caused by careless backfilling when rocks and debris strike and break the coating.

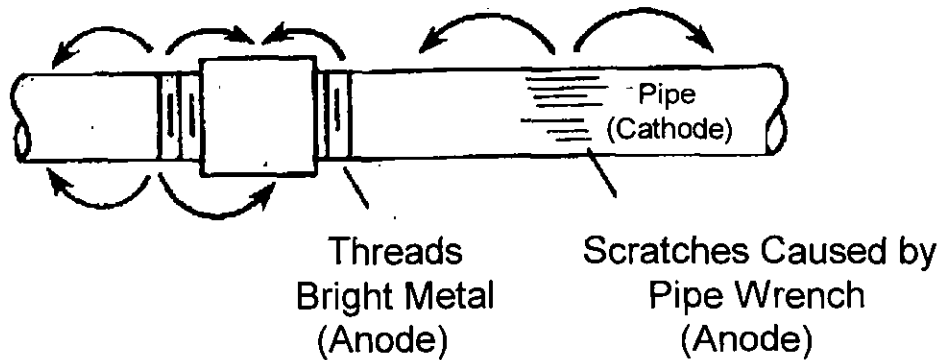
## COMMON CAUSES OF CORROSION IN GAS PIPING SYSTEMS

FIGURE III-17 SHORTED METER SET.



An example of a galvanic corrosion cell. The tenants of this building have "shorted" out this meter by storing metallic objects on the meter set. Never allow customers or tenants to store material on or near a meter installation.

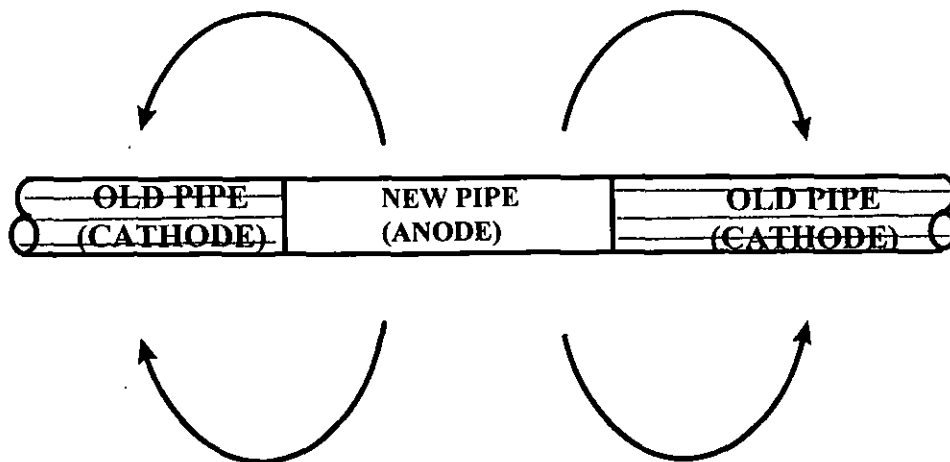
FIGURE III-18 CORROSION CAUSED BY DISSIMILAR SURFACE CONDITIONS.



**(Corrosion caused by dissimilar surface conditions.)**

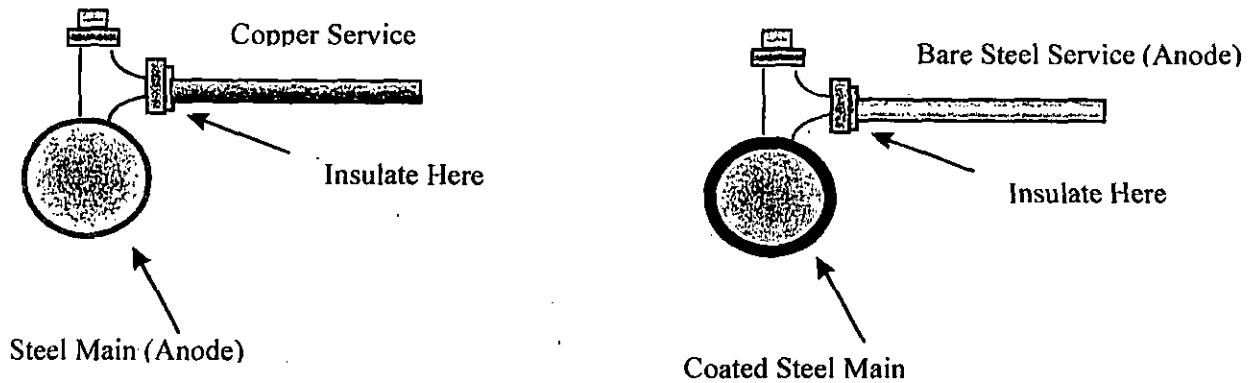
This pipe will corrode at the threads or where it is scratched. Remember to repair all cuts or scratches in the coating before burying the pipe. Always coat and/or wrap pipe at all threaded or weld connections before burying pipe.

FIGURE III-19 GALVANIC CORROSION



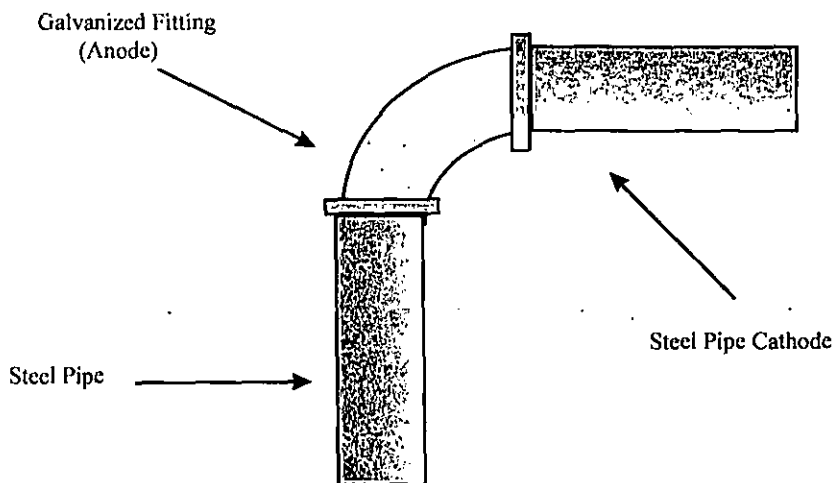
Remember, all new steel pipe must be coated and cathodically protected. The new pipe can either be electrically isolated from old pipe, or the new and old pipe must be cathodically protected as a unit.

FIGURE III-20 GALVANIC CORROSION CAUSED BY DISSIMILAR METALS.



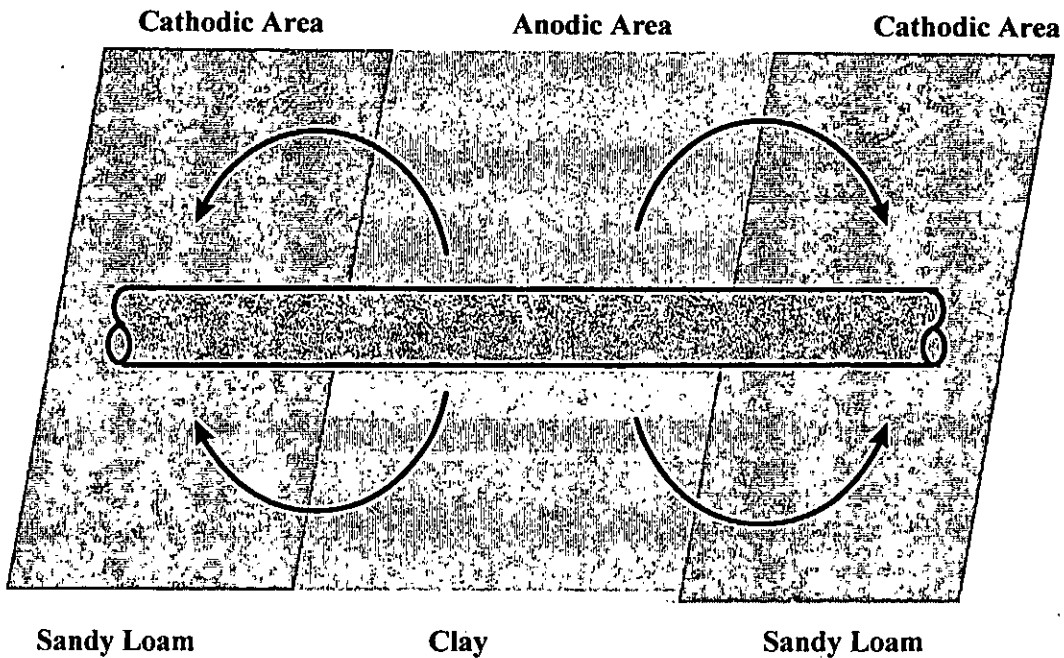
Steel is above copper in the galvanic series in TABLE 1 of this chapter. Therefore, steel will be anodic to the copper service. That means the steel pipe will corrode. The copper service should be electrically isolated from the steel main. Remember, steel and cast iron or ductile iron should not be tied in directly. Steel and cast iron should be electrically isolated. Also, coated steel pipe should be electrically isolated from bare steel pipe.

FIGURE III-21 GALVANIC CORROSION



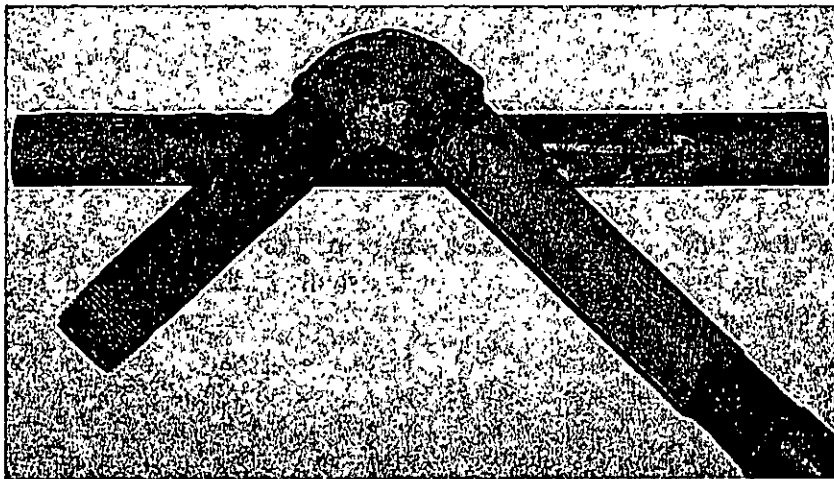
The galvanized elbow will act as an anode to steel and will corrode. Do not install galvanized pipe or fittings in system, if possible.

FIGURE III-22 GALVANIC CORROSION



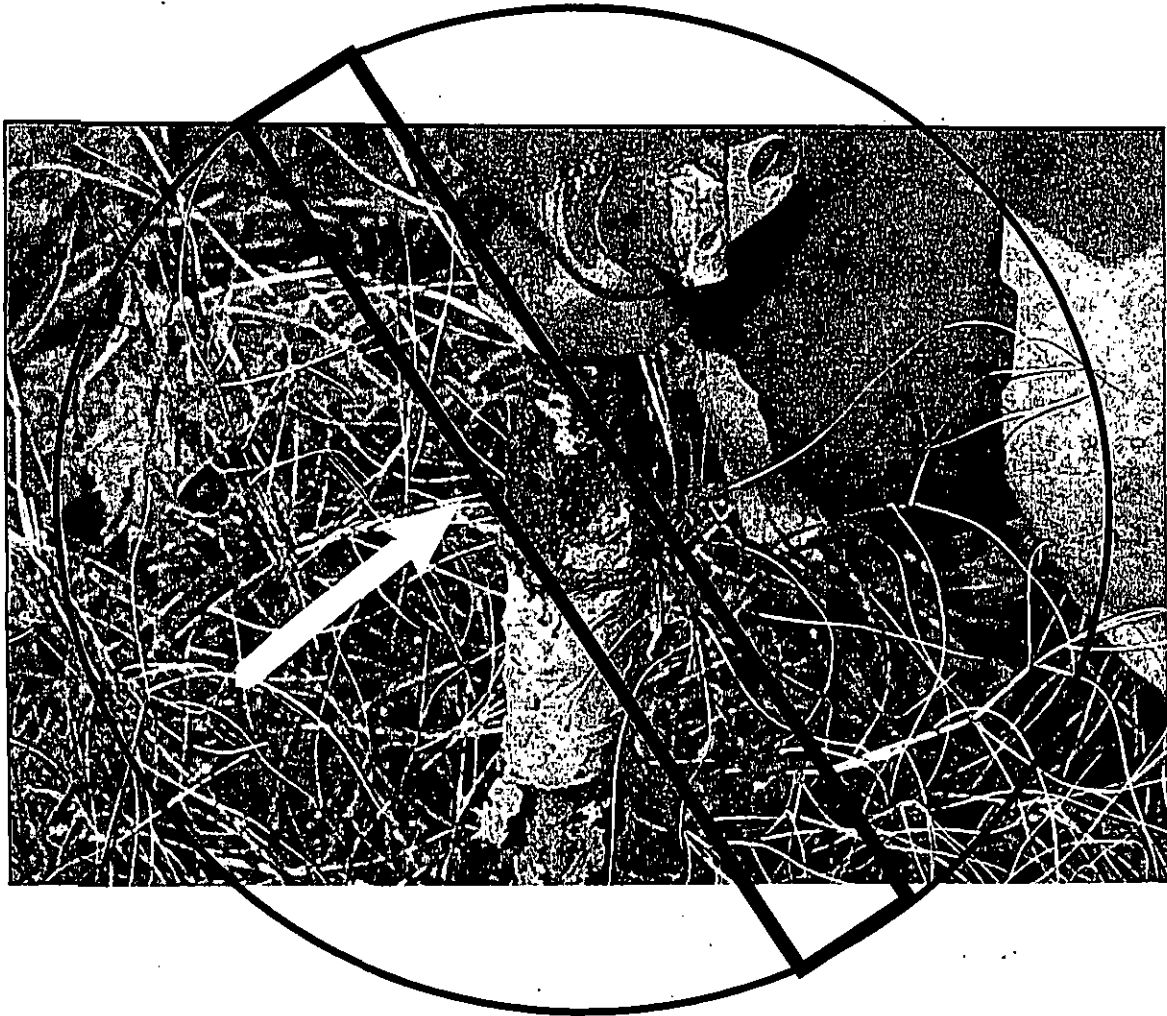
A corrosion cell can be set up when pipe is in contact with dissimilar soils. This problem can be avoided by the installation of a well-coated pipe under cathodic protection.

FIGURE III-23 POOR CONSTRUCTION PRACTICE



An example of a main which was buried without a coating or wrapping at the service connection. This corrosion problem could have been avoided by properly coating and cathodically protecting the pipe.

FIGURE III-24 ATMOSPHERIC CORROSION



Atmospheric corrosion at a meter riser, as shown above, can be prevented by either jacketing the exposed pipe or by keeping it properly painted. Corrosion is usually more severe at the point where the pipe comes out of the ground.

## CHAPTER IV

### LEAK DETECTION

This chapter contains a simplified description of the leak detection requirements contained in the pipeline safety regulations. The complete text section 192.723 can be found in 49 CFR Part 192.

#### METHODS OF DETECTING A LEAK

1. Odor. Gas is intentionally odorized so that the average person can perceive it at a concentration well below the explosive range. That odorant concentration is generally between 0.5 to 1.0 percent by volume or as local applicable codes dictate. Gas odor is a common and effective indication of a leak. **A report of gas odor should be investigated immediately.** If a leak is found, the migration pattern of the gas should be determined. If an immediate hazard is determined to exist, the hazard potential should be eliminated and the leak repaired immediately. Appendix 11 of the Gas Piping Technology Committee's "Guide for Gas Transmission and Distribution Piping Systems" (published by the American Gas Association), contains detailed information on leak classification and action criteria. The odor of gas may be filtered out as the odorized gas passes through certain types of soil. It may also be modified by passing through soil and into a sewer system containing vapors or fumes from other combustibles as well as the sewer odor itself. Therefore, odor is not always totally reliable as an indicator of the presence or absence of gas leaks. For this reason all gas leak reports should be investigated using a leak detection instrument such as a Combustible Gas Indicator (CGI) or a Flame Ionization Detector (FI). Gas personnel should remember that the primary purpose of the gas odor is to provide a warning to the public, who do not have gas detection instruments.
2. Vegetation. Vegetation in an area of gas leakage may improve or deteriorate, depending on the soil, the type of vegetation, the environment, the climate, and the volume and duration of the leak. Changes in vegetation may indicate slow below ground leaks. A vegetation survey by itself is not an acceptable method of complying with the pipeline safety regulations (see 49 CFR §192.723). Leak surveys should be conducted with leak detection equipment.
3. Insects (flies, roaches, spiders). Insects migrate to points or areas of leakage due to microbial breakdown of some components of gas. Some insects like the smell of the gas odorant. Heavy insect activity, particularly near the riser, the gas meter, or the regulator, can sometimes indicate a gas leak.
4. Fungus-like Growth. Such growth in valve boxes, manholes, etc., may indicate gas leakage. These fungi grow best where there is a lack of oxygen, such as in a gas leak area. The color of the growth is generally white or grayish-white similar to a coating of frost. All such indications should be investigated with a leak detection instrument. Personnel should never enter manholes or other confined spaces without first testing oxygen levels and gas concentrations. Check Occupational Safety and Health Administration (OSHA) regulations concerning confined space entry for further details on this subject.

5. Sound. Listen for leaks. A hissing sound at a bad connection, a fractured pipe, or a corrosion pit is the usual indication of a gas leak. Using a soap solution directly on the pipe or fitting will indicate the presence of a leak. If a strong gas odor is in the air, care should be taken to turn on and zero gas detection equipment away from the area where the odor is present.
6. Unaccounted for Gas. A possible leak is indicated when an off-peak reading of a master meter with a known average seasonal utilization rate, shows unaccountably high usages rate. Periodic off-peak checks (preferably in the summer months from midnight to 3 or 4 a.m.) can be averaged to provide data for comparison in future checks. This method may indicate a leak on the system, but will not provide a location for the leak. It is also most effective if consumption figures are known for a time period before the leak(s) occurred. A comparison of bills from the gas supplier showing gas consumption may also indicate leakage on the system. This procedure is also most effective when comparing consumption during summer months over a period of several years. If excess consumption is suspected, the system should be leak surveyed using gas detection equipment.

Gas leaks in residential areas (served by a master meter as well as by customer meters) can be detected by comparing the total consumption registered on the customer meters with that registered on the master meter. If the master meter reading is greater than that recorded by adding all the unit meter readings, then a leak probably exists in the distribution system. This condition may also indicate gas theft or a malfunctioning meter problem. If this method is used, the individual or customer meters should be read on the same day as the master meter. This will allow a more accurate comparison of gas volumes.

For a municipal system, an unexpected increase in the amount of natural gas purchased from the transmission company for a given month, as compared to past gas consumption for the same month, may indicate a leak in the system. The operator is cautioned that changes in load factors and weather must be considered when using this method. The operator should be sure to compare similar time periods, as a change in the meter reading cycle will affect this process. Dividing the gas purchased by the number of days in the billing cycle will give an average per day consumption, which would be more accurate to use in comparing bills. Low load periods such as the summer months would provide the best data.

7. Soap Solutions. A soap solution can pinpoint the location of a leak on an exposed pipe, on the riser, or on the meter. The solution is brushed or sprayed on and the location of bubbling indicates leakage. When excavating underground piping to investigate a suspected leak location, the pipe should be brushed clean and completely expose the top, sides and bottom. Many leaks are found on the bottom of the pipe. A mirror may be used to observe the underside of the pipe. NOTE: It is recommended that a soap solution specifically designed for pipelines be used.
8. Leak Detection Instruments. Gas leak indicators are sophisticated instruments that require regular care, maintenance, and calibration, and should be used by trained personnel. Two types are commonly used by the gas industry for surveying and pinpointing leaks:
  - Combustible gas indicator (CGI),

- Flame ionization (FI) gas detector.

A third type of instrument, called a bead sensor type detector, is most often used for inspecting exposed piping and appliances to pinpoint leaks on those facilities. Bead sensor instruments are not generally used for leak surveys of underground piping.

#### DESCRIPTION OF LEAK DETECTION EQUIPMENT

Combustible gas indicator. The CGI (FIGURE IV-3) consists of a meter, a probe, and an aspirator bulb. The bulb is pumped by hand to bring a sample of air into the probe and the instrument. The dial on the instrument indicates the percentage of flammable gas in air (percent gas scale) or percent of the lower explosive limit (LEL) scale. These instruments must be calibrated for the type of gas in the system. The CGI should be calibrated for natural gas for use on a natural gas system.

#### FIGURE IV-3

These are pictures of CGIs. RSPA recommends that a two-scale meter be purchased (LEL and percent gas).

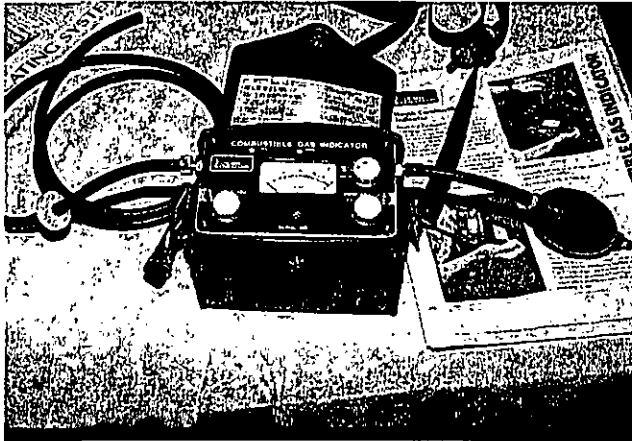


FIGURE IV-3A

Example of today's new CGI technology, which is motor driven and gives digital readouts.

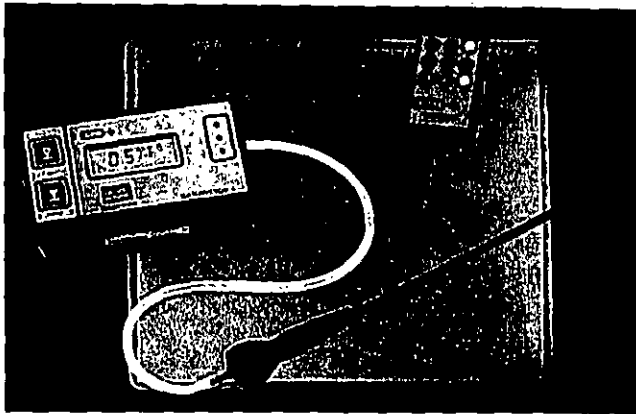
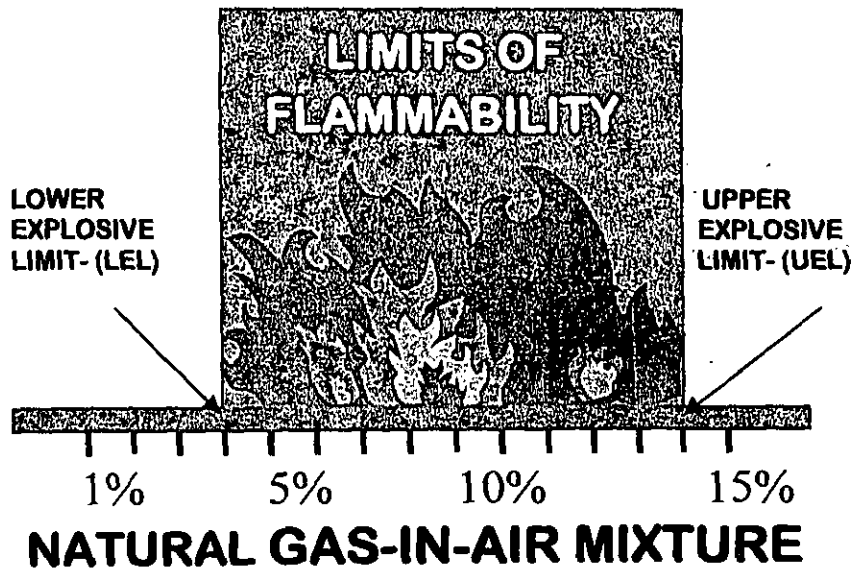


FIGURE IV-4



This is an illustration of the lower and upper explosive limits for natural gas. Typical natural gas is flammable in 4 to 14 percent natural gas in air mixture. In a confined space, a 4 to 14 percent mixture can be explosive.

The CGI is not suitable for above ground surveys. The CGI was designed primarily for use in a confined space. Its two main applications for outside surveys are termed "available openings" and "bar holing." A bar hole is a small diameter hole made in the ground in the vicinity of gas piping to extract a sample of the ground atmosphere for leak analysis. NOTE: Use extra caution when bar holing in the area of polyethylene pipe.

The CGI instruments are also useful in building surveys and in areas within a building, such as heater closets, and other confined areas. The bead sensor unit is also used in these locations. However, it does not give readings in percent of gas or percent of LEL, and must not be used for determining if a hazard exists. A CGI should always be used first when entering a building to determine if a hazardous atmosphere is present. Once the atmosphere has been determined to be non-hazardous (no LEL or gas readings), a bead sensor may be used for an inside leak survey.

One person can operate the CGI. Leak location is accurate and minimal training is necessary to use the instrument. The cost of a CGI is substantially lower than an FI unit.

The Flame Ionization (FI) detector uses a hydrogen fuel to power a small flame in a detector cell. A pump or venturi system is used to pass continuous air samples through the detector cell. If the air contains hydrocarbons such as natural gas, they will be burned or ionized in the hydrogen flame. This is detected electronically and displayed on a meter readout. FI units are equipped with meters that indicate gas concentrations from 1 part per million (PPM) to 10,000 PPM (which is the same as one-percent gas in air). They are also equipped with audible alarms to alert the operator when there is a meter deflection.

Leak survey can be done more rapidly with an FI unit than with a CGI using the bar hole method. FI units can be carried by hand for a walking survey or mounted on a vehicle for a mobile survey. Any gas indications detected by the FI should be confirmed using a combustible gas indicator. Leak pinpointing is also done with a CGI.

Leak survey technicians must be trained and qualified in the operation of the FI and CGI. Additional training is required on leak survey procedures, leak classification, recognition of hazards and pinpointing. All gas personnel should also receive training on "make safe" actions. Gas operators are not required to own FI equipment or to conduct their own leak surveys. They may choose to hire a leak survey consultant to conduct inspections. Consultants should also be trained in these topics and are required to be in a drug and alcohol-testing program, the same as gas personnel.

FIGURE IV-5  
A picture of a FI unit.

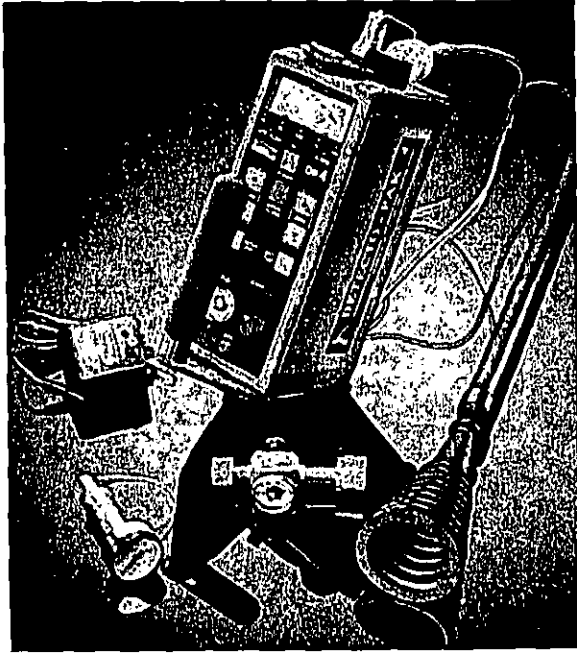


FIGURE IV-6



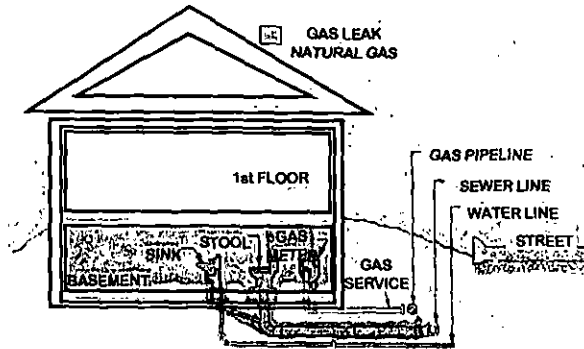
This man is checking a gas meter for leaks with a hand-carried FI unit.

**RECOMMENDED METHOD FOR SURFACE GAS DETECTION SURVEY WITH FI UNIT (NATURAL GAS SYSTEM ONLY)**

The ability of the gas to vent at the ground surface is critical for the success of a surface survey with an FI unit (FI is not to be used when the ground is frozen). A continuous sampling of the atmosphere at buried main and services should be made at ground level or at no more than 2 inches above the ground surface. In areas where the gas piping is under pavement, samplings should also be at curb line(s), available ground surface openings (such as manholes, catch basins, sewers, power, telephone duct openings, fire and traffic signal boxes, or cracks in the pavement or sidewalk), or other interfaces where the venting of gas is likely to occur. For exposed piping, sampling should be adjacent to the piping.

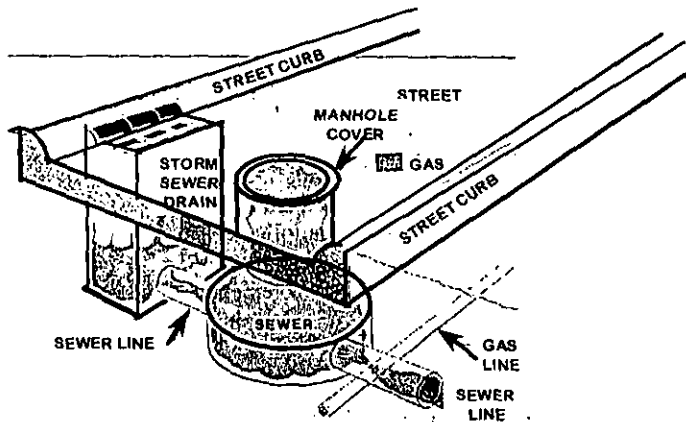
In wet, frozen, or windy conditions the gas may be restricted from venting or be rapidly diluted below FI detection levels. One method to determine if conditions are appropriate for leak survey is to re-survey a known small leak on the system. If it can be detected at normal walking or driving speeds, the survey can continue.

FIGURE IV-7



This figure shows leaking gas following the sewer line into the home, after leaking at the service tee. Natural gas can migrate in this manner.

FIGURE IV-8



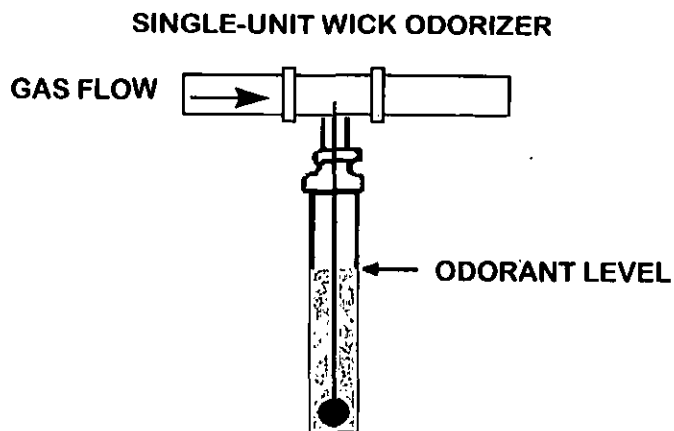
This is an example of how a gas leak can get into a sewer system. This is why it is essential when conducting a leakage survey to check all available openings, including manholes, sewers, vaults, etc. Any indication of gas in a confined space or in a building should be considered a hazardous situation. Persons should be removed from the area, and ignition sources eliminated. Once this is done, the leak investigation should begin, and the leak repaired when found. The facilities affected should be monitored, and the gas migration pattern determined. Gas should be vented from the soil and structure before allowing persons to return to the area.

## ODORIZATION EQUIPMENT

This chapter provides information for natural gas system operators who odorize their own gas. All of the equipment and illustrations refer to natural gas systems.

The following are some illustrations and brief discussions of odorization equipment used by operators of small natural gas systems.

FIGURE IV-9

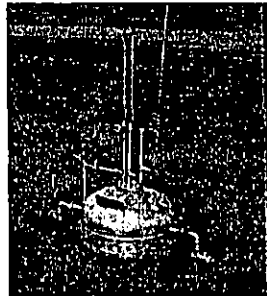
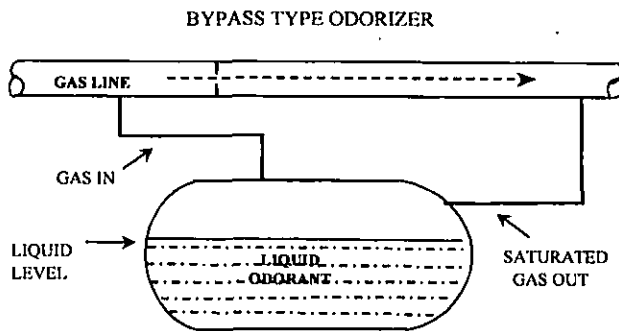


The figure shows equipment which odorizes the gas by having natural gas flow across a wick saturated with odorant (generally used for individually odorized lines such as farm taps).

**NOTE: Pitot tube version eliminates wick and lessens summer problems with odorization process.**

FIGURE IV-10

Equipment in which a portion of the main gas stream is diverted, by an orifice plate or partially closed valve in the line, through a tank provided with baffles or wicking. The odorant-saturated portion of the bypass gas is then returned to the main stream. Generally used for low, more uniform flows.



Odorization equipment may need seasonal adjustments. Valves that regulate the amount of gas diverted into the odorizer need to be adjusted between seasons of high flow and low flow of gas (winter vs. summer). Based on the equipment manufacturer's recommendation, operational instructions for specific systems can be developed. These instructions should be included in the operations and maintenance plan.

## **Equipment Selection Considerations**

Selection of the appropriate odorant and odorizing equipment may require professional advice. Operators should consult with an odorant and/or equipment supplier who can help guide odorant selection. These persons can evaluate an operator's unique pipeline situation and advise on the best odorant and the best equipment. Operators are encouraged to consult with more than one of these organizations to obtain the best odorant and equipment for the best price.

## **Types of Odorants**

Most odorants used in the United States are mercaptans or mercaptan sulfide blends, both of which contain tertiary butyl mercaptans as their main component. The only other odorant in wide use is cyclic sulfide (thiophane), which is mainly used in gas systems containing natural odorants. It is also used in farm tap odorizers.

The human sense of smell is very discerning and can detect mercaptans at a concentration of only 1 part per billion (ppb), which is currently beyond the capabilities of most instruments. The sulfur content of the odorants in the gas stream can be measured by gas analysis, which may then be used to determine if there is sufficient odorant.

The main types of detectors are odor concentration meters, titrators, and gas chromatographs dedicated to sulphur analysis. Of these instruments, the most common is the odor concentration meter. The pipeline safety regulations require operators to odorize a combustible gas in a distribution pipeline. The operator is referred to 49 CFR §192.625 for the existing requirements regarding odorization of gas.

## **Discussion of Odor Testing Instruments**

Odor testing instruments are used to determine the lowest concentration at which gas can be detected through odor (see FIGURE IV-11). The unit is actually a measuring device that indicates the percent of gas by volume in a sample when an odor is detected. To determine the odor threshold level, the unit is used in an area where it can draw in fresh air and be connected to a gas source. A blower in the unit draws ambient air through the analyzer and out the exhaust chamber. The procedure for running a test is as follows: After the instrument is connected to gas and running, quickly open the gas valve fully to make certain that gas is entering the instrument and then shut the valve quickly. Wait for any odor to dissipate and then proceed with the test. With just air coming from the exhaust port, inhale or "sniff" at the opening. There are two important points to remember when running a test. First, put the nose as close to the opening as possible (see FIGURE IV-12), as this is the location at which the instrument is calibrated. If the operator does not put his or her nose close to the opening, the sample will be diluted by surrounding air and not representative of the percent gas shown by the odor testing instrument. Second, after sniffing at the opening, immediately withdraw the nose to fresh air and take a breath. If the nose is left at the opening, the mercaptan odor will temporarily deaden the operator's sense of smell.

To repeat, take a sniff or two of only air at the opening, getting a breath of fresh air between sniffs, and become familiar with the smell of the air coming from the instrument. The operator does this because each instrument has its own unique background odor. After a couple of sniffs of air at the opening, slowly open the gas valve and sniff. Continue to open and sniff, getting a breath of fresh air between sniffs. Repeat this procedure until a change in odor can be detected. At that point record the percentage of gas and mark it "threshold." Threshold, as used here, is the minimum concentration of a gas in air at which one can detect a change in odor. The odor cannot be readily identified at that concentration, but a change in odor is barely detectable. Do not shut the valve but continue to open and sniff (getting a fresh breath in between, and remembering to put the nose as close as possible) until there is a sufficient odor for the operator to decide that the odor is a readily detectable gas odor. Record that reading and mark it "readily detectable." Turn off the gas valve at this point.

Do not skip the threshold part of the test. This part of the test is very important because it slows the operator's decision process and prevents him from making a premature decision. Manufacturers recommend that odor testing instruments be recalibrated on an annual basis, and are currently offering to update old instruments.

#### Monitoring Techniques

- Operators of master meter or small natural gas systems should periodically verify the odor level with the gas company or have a consultant run an odor test using some type of odor testing instrument on the gas in the system to determine if it is properly odorized. The best time would be when there is a low usage of gas by customers. Operators should check with their respective state regulatory agencies to see whether there are additional requirements.
- Operators should include as an operating procedure the requirement that "sniff tests" be made whenever a meter set, repair to system, or leak check is made. A sniff test is when one or more observers smell gas from an open valve, or gas burner. The name of the person, the date, and location of the test must be kept on file.
- Operators should make a sniff test at extremities of the system at least once a month.

FIGURE IV-11

A picture of an odor testing instrument.

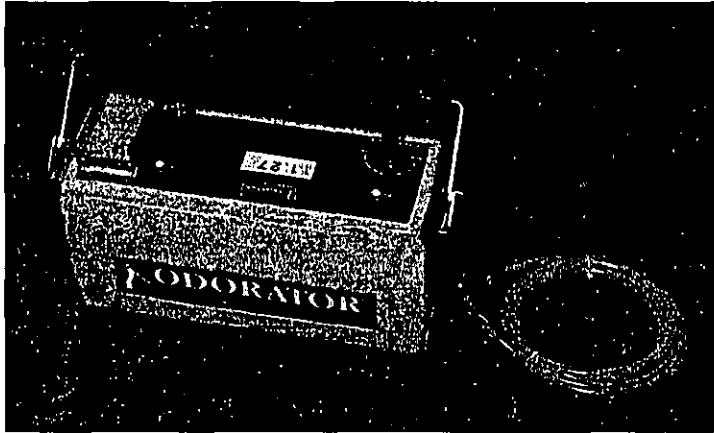
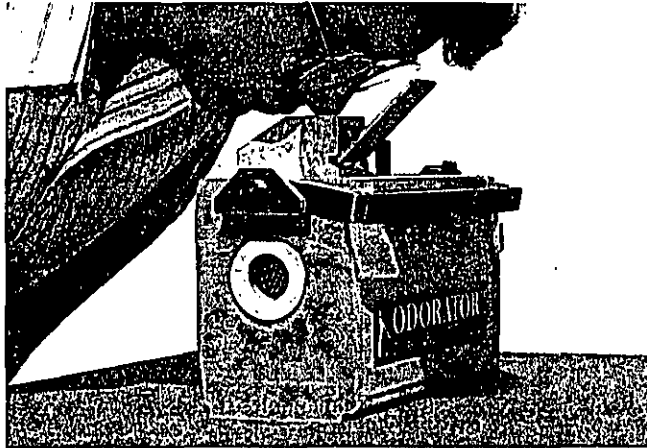


FIGURE IV-12

This man is conducting a sniff test using an odor testing instrument.



## RECORDS

Operators must record all leakage surveys, leaks found, and all repair data. The sample form in Appendix B may be used. Remember that operators can develop their own forms (see APPENDIX B, FORM 2).

Records must include leak reports received from customers or tenants. A sample form for the recording of these leak reports is in APPENDIX B, FORMS 2 AND 3.

## GPTC – GUIDE MATERIAL FOR “LEAK CLASSIFICATION AND ACTION CRITERIA”

GPTC has developed guidance material for “Leak Classification and Action Criteria” (see FIGURE IV-13, TABLES 3A, 3B AND 3C).

## FOLLOW-UP INSPECTION

The adequacy of leak repairs should be checked before backfilling. The perimeter of the leak area should be checked with a CGI. Where there is residual gas in the ground after the repair of a Class 1 leak, a follow-up inspection should be made as soon as practical after allowing the soil atmosphere to vent and stabilize. OPS suggests follow-up inspection within 24 to 48 hours, but in no case later than 1 month following the repair. In the case of other leak repairs, qualified personnel should determine the need for a follow-up inspection.

A method to remember when investigating gas leaks and determining the classification is to ask, “WHERE is the Gas?” as follows:

- Where is the gas? (Use a detector to confirm gas is present)
- How much is there? (Take readings on the CGI)
- Extent of the spread? (Determine the migration pattern)
- Relation to other structures? (Is gas detected in or near buildings or in manholes?)
- Evaluate/evacuate? (Classify the leak and take appropriate action)

**TABLE 3A-LEAK CLASSIFICATION AND ACTION CRITERIA-GRADE 1**

GRADE	DEFINITION	ACTION CRITERIA	EXAMPLES
1	A leak that represents an existing or probable hazard to persons or property, and requires immediate repair or continuous action until the conditions are no longer hazardous.	<p>Requires <i>prompt action</i>* to protect life and property, and continuous action until the conditions are no longer hazardous.</p> <p>*The prompt action in some instances may require one or more of the following:</p> <ul style="list-style-type: none"> <li>a. Implementation of company emergency plan (§192.615).</li> <li>b. Evacuating premises.</li> <li>c. Blocking off an area.</li> <li>d. Rerouting traffic.</li> <li>e. Eliminating sources of ignition.</li> <li>f. Venting the area.</li> <li>g. Stopping the flow of gas by closing valves or other means.</li> <li>h. Notifying police and fire departments.</li> </ul>	<ol style="list-style-type: none"> <li>1. Any leak which, in the judgment of operating personnel at the scene, is regarded as an immediate hazard.</li> <li>2. Escaping gas that has ignited.</li> <li>3. Any indication of gas which has migrated into or under a building, or into a tunnel.</li> <li>4. Any reading at the outside wall of a building, or where gas would likely migrate to an outside wall of a building.</li> <li>5. Any reading of 80% LEL, or greater, in a confined space.</li> <li>6. Any reading of 80% LEL, or greater in small substructures (other than gas associated substructures) from which gas would likely migrate to the outside wall of a building.</li> <li>7. Any leak that can be seen, heard, or felt, and which is in a location that may endanger the general public or property.</li> </ol>

TABLE 3B-LEAK CLASSIFICATION AND ACTION CRITERIA-GRADE 2

GRADE	DEFINITION	ACTION CRITERIA	EXAMPLES
2	<p>A leak that is recognized as being non-hazardous at the time of detection, but justifies scheduled repair based on probable future hazard.</p>	<p>Leaks should be repaired or cleared within one calendar year, but no later than 15 months from the date the leak was reported. In determining the repair priority, criteria such as the following should be considered:</p> <ol style="list-style-type: none"> <li>Amount and migration of gas.</li> <li>Proximity of gas to buildings and subsurface structures.</li> <li>Extent of pavement.</li> <li>Soil type and soil conditions (such as frost cap, moisture and natural venting).</li> </ol> <p>Grade 2 leaks should be reevaluated at least once every six months until cleared. The frequency of reevaluation should be determined by the location and magnitude of the leakage condition.</p> <p>Grade 2 leaks may vary greatly in degree of potential hazard. Some Grade 2 leaks, when evaluated by the above criteria, may justify scheduled repair within the next 5 working days.</p> <p>Others will justify repair within 30 days. During the working day on which the leak is discovered, these situations should be brought to the attention of the individual responsible for scheduling leak repair.</p> <p>On the other hand, many Grade 2 leaks, because of their location and magnitude, can be scheduled for repair on a normal routine basis with periodic reinspection as necessary.</p>	<p>A. <i>Leaks Requiring Action Ahead of Ground Freezing or Other Adverse Changes in Venting Conditions.</i></p> <p>Any leak which, under frozen or other adverse soil conditions, would likely migrate to the outside wall of a building.</p> <p>B. <i>Leaks Requiring Action Within Six Months</i></p> <ol style="list-style-type: none"> <li>Any reading of 40% LEL, or greater, under a sidewalk in a wall-to-wall paved area that does not qualify as a Grade 1 leak.</li> <li>Any reading of 100% LEL, or greater, under a street in a wall-to-wall paved area that has significant gas migration and does not qualify as a Grade 1 leak.</li> <li>Any reading less than 80% LEL in small substructures (other than gas associated substructures) from which gas would likely migrate creating a probable future hazard.</li> <li>Any reading between 20% LEL and 80% LEL in a con-fined space.</li> <li>Any reading on a pipeline operating at 30 percent SMYS, or greater, in a class 3 or 4 location, which does not qualify as a Grade 1 leak.</li> <li>Any reading of 80% LEL, or greater, in gas associated sub-structures.</li> <li>Any leak which, in the judgment of operating personnel at the scene, is of sufficient magnitude to justify scheduled repair.</li> </ol>

Formatted: Bullets and Numbering

Formatted: Bullets and Numbering

**TABLE 3C-LEAK CLASSIFICATION AND ACTION CRITERIA-GRADE 3**

GRADE	DEFINITION	ACTION CRITERIA	EXAMPLES
3	A leak that is non-hazardous at the time of detection and can be reasonably expected to remain non-hazardous.	These leaks should be reevaluated during the next scheduled survey, or within 15 months of the date reported, whichever occurs first, until the leak is regraded or no longer results in a reading.	<p><i>Leaks Requiring Reevaluation at Periodic Intervals</i></p> <ol style="list-style-type: none"> <li>1. Any reading of less than 80% LEL in small gas associated substructures.</li> <li>2. Any reading under a street in areas without wall-to-wall paving where it is unlikely the gas could migrate to the out-side wall of a building.</li> <li>3. Any reading of less than 20% LEL in a confined space.</li> </ol>

## CHAPTER V

### UNACCOUNTED FOR GAS

Unaccounted-for gas is the difference between the amount of gas purchased and the quantity of gas sold, whether it is more or less.

The term, "unaccounted-for gas," does not always indicate a leak. Leakage is only one of a number of factors contributing to unaccounted-for gas. There are 17 or more conditions that may contribute to unaccounted-for gas. For a given gas leak, each system will be affected differently by these conditions because there are no two systems exactly the same as to piping and customer mix.

The causes for unaccounted-for gas can be grouped into two categories. One is leaks and the other gas measurement. Leaks are defined as gas escaping to the atmosphere at a given rate at an unknown location. The rate of gas loss is dependent on the pressure and the size of the hole. Normally, gas leakage will be at a fairly constant rate and will increase gradually with time if not located and repaired. Gas lost through measurement or the lack of measurement is very deceptive and at times very difficult to detect. Gas measurement is defined as the accounting of all gas bought and sold.

Let's start with the gas purchase station. This station is normally owned and maintained by the seller of the gas to the gas utility and is normally called a gate station. Very few small utilities have check meters to monitor the accuracy of these gate stations to ensure the accuracy of the measurement. It is important to know what size cubic foot of gas is being purchased. Normally the gas volume at a gate station is corrected to a temperature of 60°F at a base pressure of 4 oz. If the gas being sold is not corrected to the same conditions, there will be unaccounted-for gas.

Let's see how temperature can affect accuracy. The purchased gas volume was calculated at 60°F. At what temperature is the gas being sold? Naturally the ambient temperature affects the gas temperature. The amount of the effect is determined by the depth of the pipeline in the ground. The deeper the pipe, the more insulation the ground offers and the closer the gas temperature will be to 60°F. If the gas mains and services are aboveground or close to the surface, the gas temperature is relatively close to the air temperature on any given day.

For every 5°F above or below 60°F, the gas volume will change by about 1 percent. This may not sound like much; however, if the average winter temperature for a 3-month period is 30°F, 6 percent unaccounted-for gas can be expected for this period. This loss can only be corrected by the use of temperature compensated meters. No temperature multiplier can be used to correct the volume unless a temperature volume instrument is used on the sales meter. Gas utilities sell the majority of their gas during the winter months so the small amount of gas sold during the hot summer will offset the losses.

How does metering pressure affect unaccounted-for gas? Gas is purchased at a 4-oz. pressure or at least the volume is corrected to 4 oz. As the pressure increases above the 4-oz. base, the

volume of gas becomes smaller. For every 2-oz. change above the 4 oz., there is an expected loss of about 1 percent. Therefore, if the service regulators are delivering 8-oz. gas through the meters, approximately 2 percent unaccounted-for gas can be expected. For delivery at 10 oz., approximately 3 percent unaccounted-for gas can be expected. Pressure compensated indexes are not normally used for domestic house meters. However, they are available for the large commercial and industrial meters. If a pressure compensated index is used, care must be taken to ensure that the meter pressure is the same as the index pressure. The pressure compensated index will only correct for a constant pressure.

Pressure and temperature errors in gas measurement are second only to leaks as a contributing factor to unaccounted-for gas. By calculating unaccounted-for gas as a percentage of the total gas purchased, it can be determined whether the loss is due to leaks or gas measurement.

If all the loss is due to leaks, there will be a higher percentage of unaccounted-for gas during the summer months. The percentage due to leaks may be slightly higher in the winter if the gas system pressure is raised, but it will not normally be very noticeable. Gas loss due to pressure differences will, if the pressure at the meter is the same in the summer and winter, show the same percentage of unaccounted-for gas throughout the entire year.

Loss due to temperature will show a higher percentage during the cold months, and, after leaks, can be the most costly. In summary, if the percent of unaccounted-for gas is up during the summer months, look for leaks. If it increases during the winter months, look for measurement errors probably caused by temperatures.

There are many other causes for unaccounted-for gas, one being inaccurate gas meters. To determine the overall accuracy of the meters, take a random sample of meters of all ages and test them. By averaging the accuracy of the sample meters, the overall accuracy of the meters in the entire distribution system can be estimated. Taking the average of the meters brought in during a regular changeout will only indicate the accuracy of the meters that have been installed for a long period. If the overall accuracy is poor, it may indicate that the changeout period should be shortened to improve accuracy.

Gas theft, bad meters, or dead meters will normally show up in the monthly billing, so always be on the lookout for unexplained reductions in gas usage for a particular customer. Remember that fill comparisons, supplemented by an alert meter reader, are the best way to detect gas thefts. The hardest theft to detect is when only a small amount of gas is stolen each month. This can be accomplished by reversing the meter in the line for a few days a month or with a meter bypass. Gas theft, accomplished via bypass or by other methods, will cause hazardous conditions that warrant a safety investigation. The thief in some cases is nearly impossible to catch unless elaborate means are taken to seal the meter, the meter nuts, stopcocks, regulators, and other related equipment. The old adage, "if there is a will, there is a way," applies to the gas thief.

Unaccounted-for gas is a serious problem. By taking a positive approach, the majority of the causes can be determined and corrected.

## CHAPTER VI

### REPAIRS AND NEW CONSTRUCTION

This chapter is designed to help the operators of small natural gas systems meet the construction and repair requirements set by the pipeline safety regulations. It outlines construction, pipe handling, and pressure testing requirements for installation of safe natural gas systems. It explains the procedures to qualify a person to make a pipe joint. It gives directions for locating "qualified persons" to do construction and repair work on a gas system. Remember, it is always the operator's responsibility to see that a contractor follows all requirements.

Manufacturers of pipe, valves, fittings, and other gas system components must design and test them to mandatory industry specifications. The specifications are incorporated by reference into 49 CFR Part 192, the gas pipeline safety regulations. Components meeting the requirements are qualified for gas service and marked with the "approved" markings. In addition, manufacturers usually develop procedures for joining their products and joining other materials to their products. Manufacturers produce manuals and provide procedures for installation and operation that must be incorporated in the operator's operations and maintenance plans.

#### PLANNING AHEAD

It is essential that a natural gas operator know the types of material and various elements of its gas piping system. A piping system consists of pipes, valves, fittings, regulators, relief devices, and meters. The operator must select components for the system that meet all applicable standards and that comply with the pipeline safety regulations. For example, to develop a cathodic protection program, it is necessary to know the type of metal piping in the system.

Records of the type and location of system components are critical for planning purposes. Operators who are uncertain of the type of material in their gas piping system must identify the materials. This may be done in one of the following ways:

- Contact previous owners of the system.
- Contact the contractor who installed and/or maintained the system.
- Check state, city or county permits.
- Carefully expose the pipe in certain locations to determine the type of materials and components.

Operators unfamiliar with the types of material must rely on a qualified person to identify the components. These investigations may require the operator to engage a consultant if in-house expertise is lacking.

## EXCAVATION

Excavation must not be conducted in and near the location of an underground facility without first ascertaining the location of all underground facilities which could be affected by the excavation.

Prior to any excavation, each excavator must serve notice of intent to excavate to the One-Call Center serving the area in which the proposed excavation will occur. Notice must be given to the local One-Call Center in accordance with local state regulations in advance of excavation. This requirement may vary from 24-72 hours.

## EMERGENCY EXCAVATION

An emergency excavation is an excavation which is performed to eliminate an imminent damage to life, health, or property. Oral notice of the emergency excavation must be given as soon as possible to the One-Call Center or to each operator having underground facilities in the area. If necessary, emergency assistance must be requested from each operator to locate and protect its underground facilities.

## PRECAUTIONS TO AVOID DAMAGE

Each person responsible for an excavation or demolition operation must:

- Plan the excavation to avoid damage to underground facilities in and near the construction area.
- Maintain a safe clearance between the underground facilities and the cutting edge of any mechanized equipment, taking into account the known limit of control of the cutting edge to avoid damage to facilities.
- Provide support for underground facilities in and near the construction area during excavation and backfilling operations to protect the facility.
- Dig test pits to determine the actual location of gas facilities if these facilities or utilities are to be exposed or crossed.

## EXCAVATION: REPAIR OF DAMAGE

Each person responsible for excavation operations which results in damage to an underground facility must, immediately upon discovery of that damage, notify the operator of the facility of the location and nature of the damage. The operator shall have reasonable time to accomplish necessary repairs before the excavation or backfilling in the immediate area of damage is continued.

Each person responsible for an excavation operation that damages an underground facility and permits the escape of any flammable or toxic gas shall, immediately upon discovery of that

damage, notify the operator, local police, and the local fire department. Then take any actions necessary must be taken to protect persons and property and to minimize the hazards until arrival of the operator's personnel or police and fire departments.

### RECOMMENDATION

It is in the public interest to promote the protection of citizens, workers, and property in the vicinity of underground facilities. Also, it is in the public interest to promote the health and well being of the community by preventing the interruption of essential services that may result from damage to underground facilities. It is recommended that all underground (gas) utility operators become members of, participate in, and share in the cost of their area's One Call Center.

### PIPE INSTALLATION, REPAIR, AND REPLACEMENT: GENERAL COMMENTS

Gas service lines must be installed with at least 12 inches of cover in private property and at least 18 inches of cover in streets and roads. Gas mains must have at least 24 inches of cover.

Qualified personnel must conduct installation of gas pipes. Local gas utilities and local gas associations may be able to recommend qualified persons/contractors who have the necessary background for gas pipe installation. However, contractor work must be supervised carefully. The following sections list the minimum requirements for pipe joining and construction activities.

### METALLIC PIPE INSTALLATION

All the conditions listed below must be met when installing metallic pipe.

- Make each joint in accordance with written procedures that have been proven by test or experience to produce strong, gas-tight joints.
- Obtain and follow the manufacturer's recommendations for each specific fitting used. See FIGURE VI-1 for examples of manufacturer's instructions for a mechanical coupling. Include the manufacturer's procedures in the operations and maintenance plans.
- Handle pipe without damaging the outside coating. If the coating is damaged, accelerated corrosion can occur in that area.
- Coat or wrap steel pipe at all welded and mechanical joints before backfilling.
- Pressure test new pipe for leaks before backfilling. Mains and services to be operated at 60 psig or less must be tested to 100 psig. This test must be maintained for at least 1 hour. When performing maintenance, short sections of pipe may be pre-tested prior to installation.
- Support the pipe along its length with proper backfill. Make certain that backfill material does not contain any large or sharp rocks, broken glass, or other objects that could scrape the coating or dent the pipe.

- Cathodically protect steel pipes.
- Electrically insulate dissimilar metals (see CHAPTER III for illustrations).

If welding steel is necessary in a pipeline, review the pipeline safety regulations in Subpart E of 49 CFR Part 192. Remember: welding must be performed in accordance with established written welding procedures that have been qualified and tested to produce sound ductile welds, and must be performed by welders who are qualified for that welding procedure. Some states have special welding certification programs.

Welding of steel pipe is difficult. Both the procedures and the personnel must be qualified for the type of weld performed. If welding is done on a gas system, qualified welders can be referred by:

- the local gas utility;
- local gas associations;
- consultants.

### PLASTIC PIPE INSTALLATION

Plastic pipe is commonly used for distribution mains and services by the gas industry. Polyethylene (PE) pipe is recommended as the most suitable plastic pipe for natural gas piping. Acceptable PE plastic pipe is manufactured according to standard ASTM D2513 and is marked with that number.

Plastic pipe is unsuitable for aboveground installation. Plastic pipe must be buried or inserted. The operator must include written joining procedures in its operations and maintenance plan. Each joint must be made in accordance with written procedures that have been proven by test or experience to produce strong gas-tight joints. Plastic pipe joining procedures can be obtained from qualified manufacturers. Do not purchase a product if the manufacturer or supplier does not certify it for qualified joining procedures.

If a contractor installs PE plastic pipe, the operator is responsible to ensure that only PE pipe manufactured according to ASTM D2513 is installed. In addition, the operator must verify that the contractor follows written joining procedures that meet the manufacturers' recommended joining procedures for each type of pipe and fitting used. No person may make a plastic pipe joint unless that person has been qualified under the applicable joining procedure by making a specimen joint that passes inspection and test.

The specimen joint must be visually examined during and after joining and found to have the same appearance as a joint or photograph of a joint that is acceptable under the procedure. In the case of heat fusion, the specimen must be cut into at least three longitudinal straps, each of which is:

- Visually examined and found not to contain voids or discontinuities on the cut surfaces of the joint area;

- Deformed by bending, torque, or impact, and if failure occurs, it must not initiate in the joint area.

A person must be requalified under an applicable procedure, if during any 12-month period that person:

- Does not make any joints under the procedure;
- Has 3 joints or 3 percent of the joints made, whichever is greater, that are found unacceptable by testing.

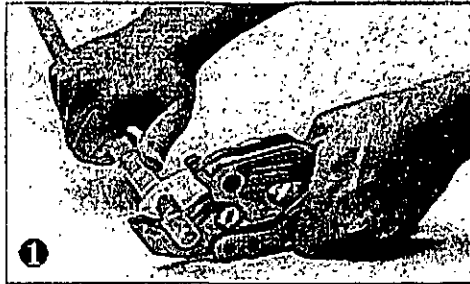
**FIGURE VI-1**

An example of a manufacturer's instruction for a mechanical coupling.

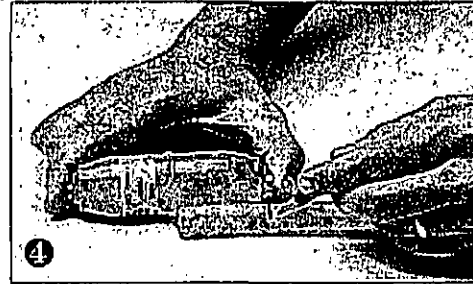
## Easy-to-install Permasert system

In addition to saving time and money, using a Perfection Gas Distribution System instills the confidence of knowing you will repeatedly achieve a safe gas-tight connection. Our easy

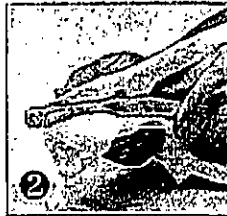
five-step installation procedure assures you of consistent positive connections that prevent pull-out of the pipe or tubing.



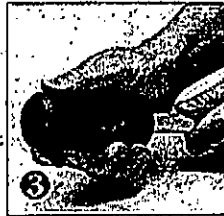
1 Cut the PE piping so that the end is square.



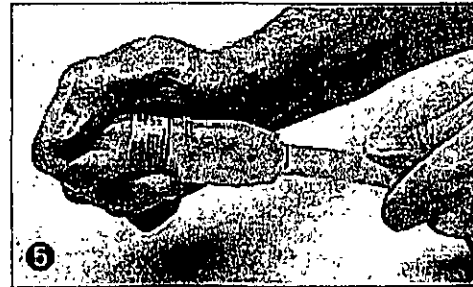
4 Use a soft felt pen, crayon or grease pencil to mark the stab depth as indicated on your Permasert package instructions. The stab depth is the approximate distance from the edge of the fusion bead to the end of the fitting body.



2 Wipe with a clean dry cloth. Inspect the last several inches of PE piping for damage. If any, cut again to remove damage area.



3 Use the Perfection chamfering tool for a proper O.D. chamfer. This chamfer permits the PE piping to be completely stabbed without affecting the internal seals.



5 Stab the PE piping into the Permasert fitting so that the stab depth mark is visible:

- Within 1/8" of moisture seal on 1/2" CTS and 1" CTS sizes
- Within 1/4" on all other sizes through 1-1/4" CTS
- Approximately 3/8" on 1-1/4" IPS and 2" IPS sizes

The PE piping must bottom out in the fitting. Pressure test the joint in accordance with your standard procedures. The reference mark can move outward up to an additional 3/8" during pressure testing.



**Perfection  
Corporation**

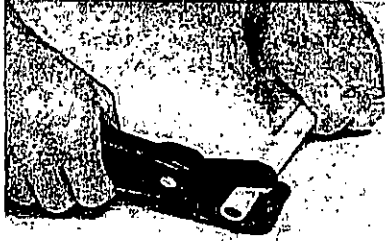
A Subsidiary of American Meter Company  
222 Lake St. • Madison, Ohio 44057-3189 USA  
Phone: 216-428-1171 • Fax: 216-428-7325  
800-544-6344

COUPLING/AHA/5M/0596

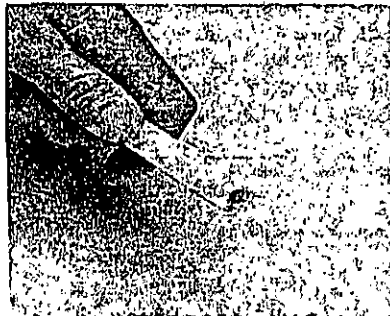
FIGURE VI-2

Example of a manufacturer's procedure for installing a specific coupling.

### ASSEMBLY INSTRUCTIONS



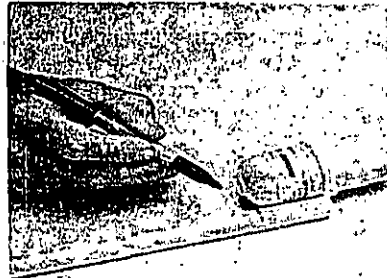
**1** Check the pipe being used to be certain of correct pipe size. Cut pipe ends square.



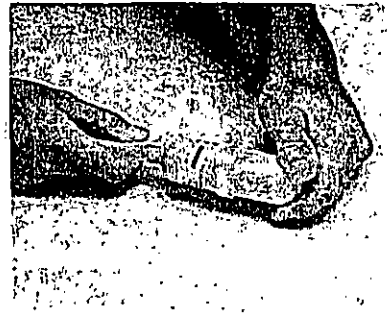
**2** Chamfer end of pipe using a chamfering tool.



**3** Clean pipe thoroughly to assure there is no dirt, grease or oil in assembly area. Also, assembly area must be free of severe scratches.



**4** Holding the end of the pipe against the collar on the fitting, mark pipe at the entrance of the fitting (this stab length is 1 7/8").



**5** Stab pipe completely into fitting so that the mark on the pipe is flush or less from the fitting entrance.

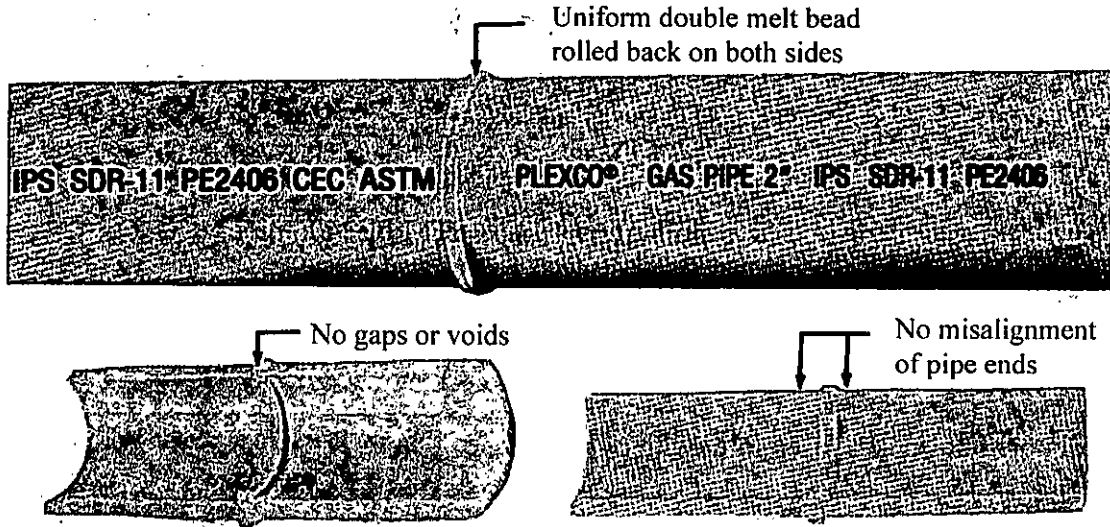
**6** Repeat steps 1 thru 5 for the other end of coupling to complete the joint.

**7** Pressure test the joint before putting it into service.

FIGURE VI-3

These are two types of fusion joints.

**BUTT FUSION JOINT**



**SADDLE FUSION JOINT**

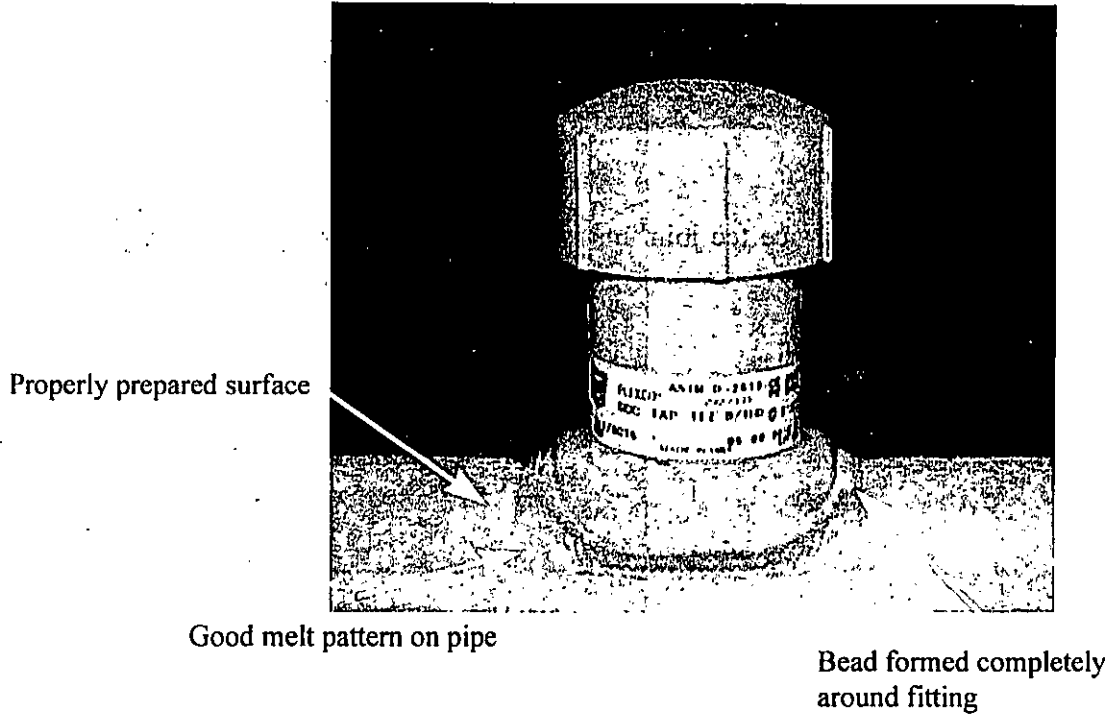
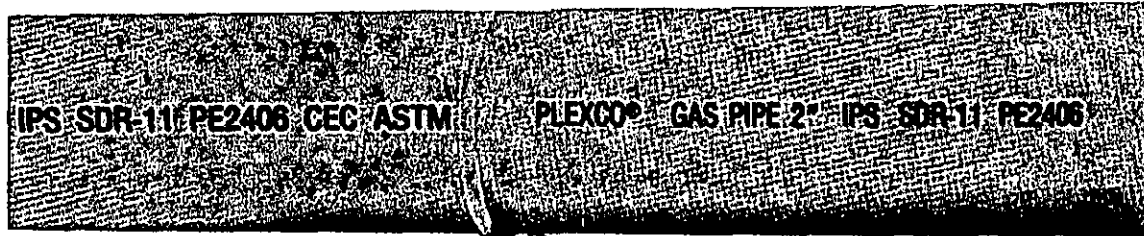


FIGURE VI-4

Bead (melted and fused portion of plastic pipe)



Close up of a well made butt fused joint made with ASTM PE2406 pipe.

**Note:** This is for illustration purposes only. Use picture and instructions in pipe manufacturer's manual.

FIGURE VI-5

An example of a socket fused joint with polyethylene pipe listed in ASTM D2513.



FIGURE VI-6

An example of a saddle service tee joint made with PE pipe listed in ASTM D2513.

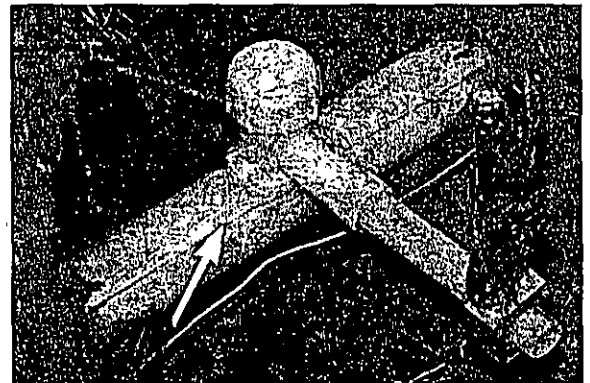
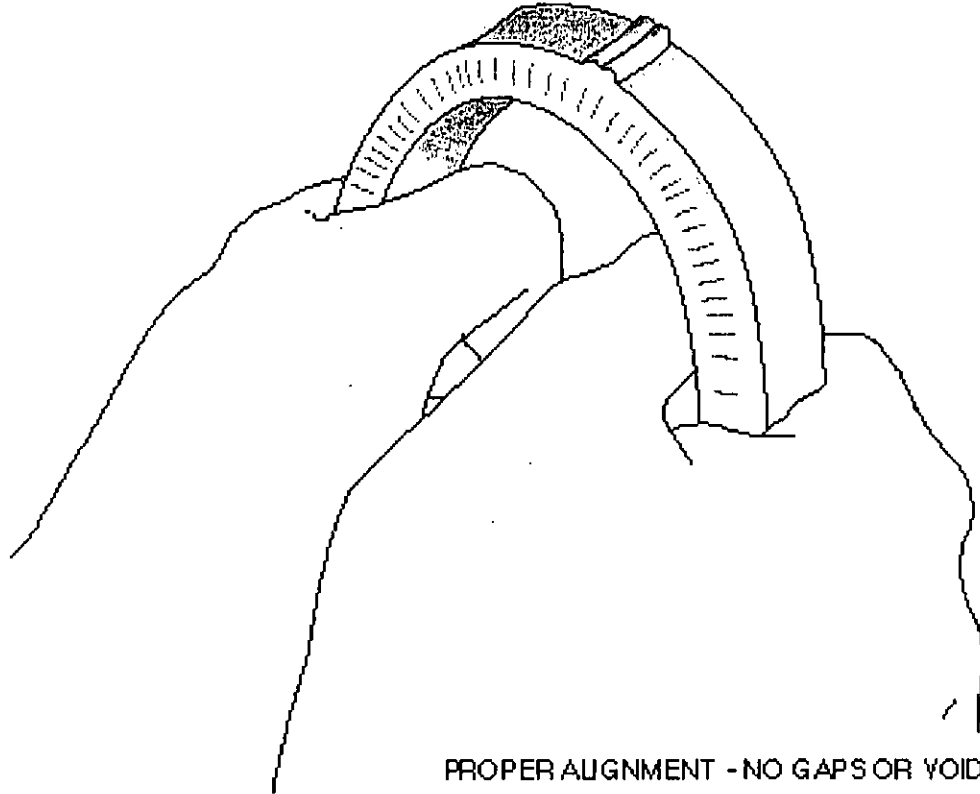


FIGURE VI-7

---

BUTT FUSION OF PIPE: ACCEPTABLE APPEARANCE

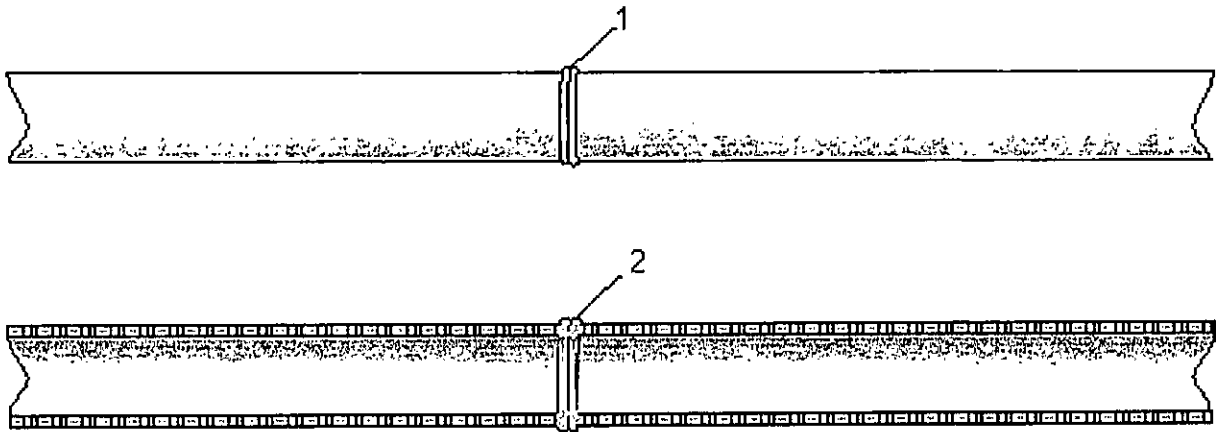
---



---

BUTT FUSION OF TUBING: ACCEPTABLE APPEARANCE

---



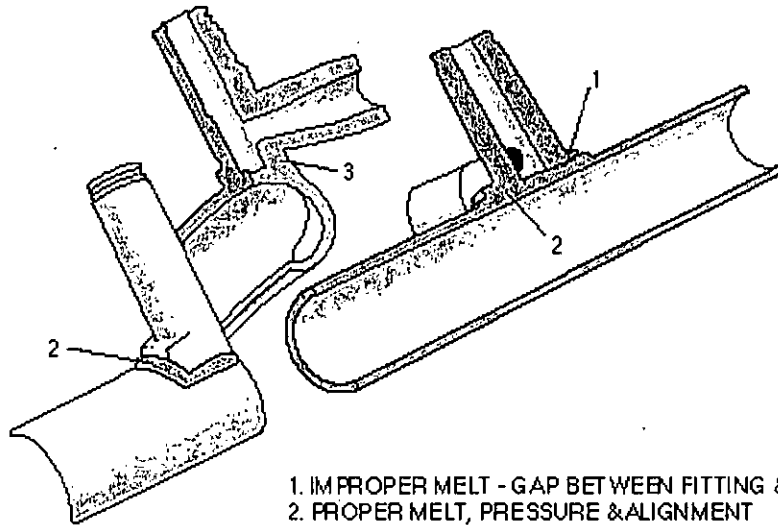
1. PROPER DOUBLE ROLL BACK BEAD
2. PROPER MELT, PRESSURE AND ALIGNMENT

FIGURE VI-8

---

SIDEWALL FUSION: ACCEPTABLE APPEARANCE

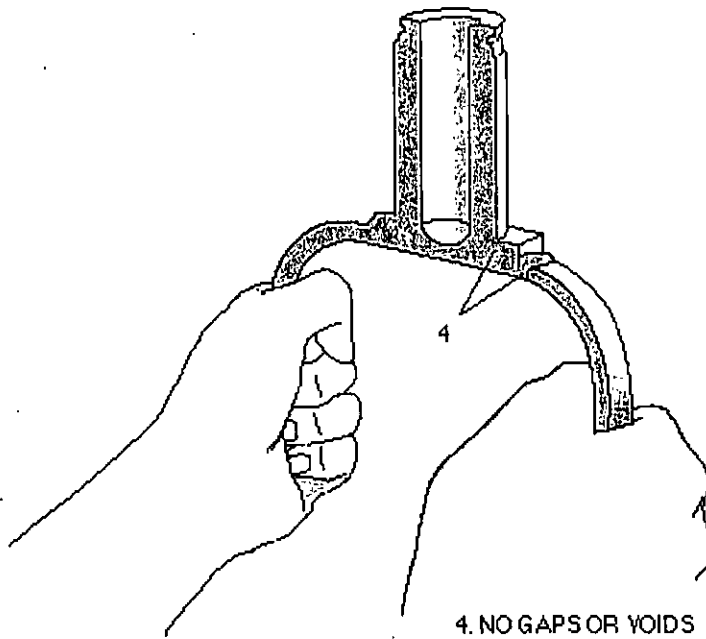
---



---

SIDEWALL FUSION: ACCEPTABLE APPEARANCE

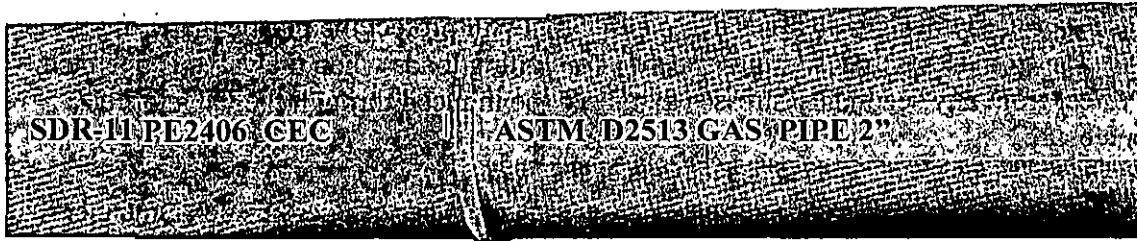
---



The general guidelines to follow when installing plastic pipe are listed below:

1. Install plastic pipe manufactured under the ASTM D2513 specification. The pipe must have ASTM D2513 marked on it.

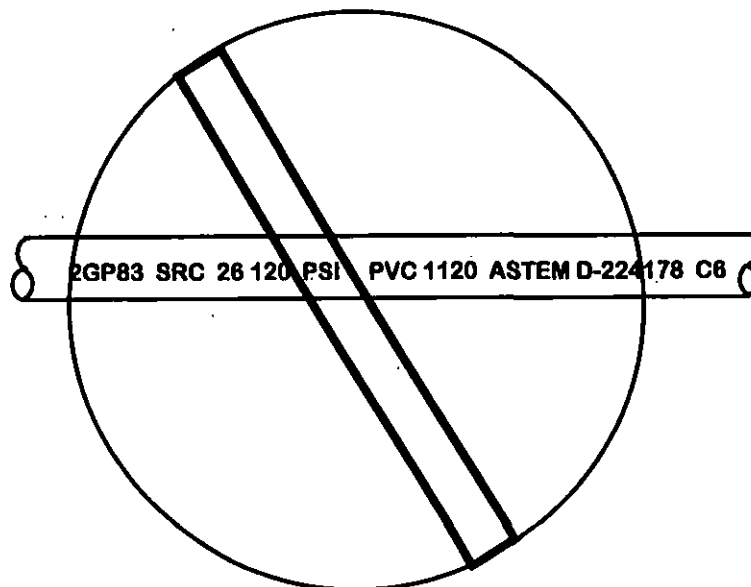
FIGURE VI-9



This is a properly marked PE pipe. ASTM D2513 is clearly marked on the pipe. If ASTM D2513 is not marked on a pipe, do not purchase it.

FIGURE VI-10

This is an example of PVC pipe not qualified for gas piping. It was manufactured according to ASTM D2241. The pipe is qualified for use as water pipe, not gas piping. Remember to look for the ASTM D2513 marking on the pipe.



2. Make each joint in accordance with written procedures that have been proven by test to produce strong gas-tight joints.

The manufacturer of the pipe or fitting should supply the operator with the procedures for each product in the manufacturer's manual. When installing the pipe, make certain that these procedures are followed. A qualified person must make all joints.

3. Install properly designed valves in a manner that will protect the plastic material. Protect the pipe from excessive twisting, shearing, or cutting loads when the valve is operated. Protect from any secondary stresses that might be induced through the valve or its enclosure.
4. Prevent pullout and joint separation. Plastic pipe must be installed in such a manner that expansion and contraction of the pipe will not cause pullout or separation of the joint. Operators unfamiliar with plastic pipe should have a qualified person perform all joining procedures.
5. When inserting plastic pipe in a metal pipe, make allowance for thermal expansion and contraction. Make an allowance at lateral and end connections on inserted plastic pipes, particularly those over 50 feet in length. *End connections must be designed to prevent pullout caused by thermal contraction.* Fittings must be able to restrain a force equal to or greater than the strength of the pipe. To minimize the stress caused by thermal contraction, pipes inserted in the summer should be allowed to cool to ground temperature before tie-ins are made. Inserted pipes, especially those pulled in, should be relaxed, mechanically compressed, or cooled to avoid initial tensile stress. Operators unfamiliar with proper insertion techniques must have a qualified person develop the procedures.
6. Repair or replace imperfections or damages before placing the pipe in service.
7. Install all plastic mains and service lines below ground level. Where the pipe is installed in a vault or other below-grade enclosure, it must be completely encased in gas-tight metal pipe with fittings that are protected from corrosion. Plastic pipe installation must minimize shear and other stresses. Plastic mains and service lines that are not encased must have an electrically conductive wire or other means of locating the pipe. Plastic lines must not be used to support external loads.

FIGURE VI-11

The following is an example of an illegal installation which does not meet federal safety standards. This is a picture of plastic pipe installed aboveground. Remember: **BURY PLASTIC PIPE!**



FIGURE VI-12

These are other examples of improper installations. Note that a trench and bell hole was dug but the operator never buried the pipe. Keep in mind that plastic pipe loses some of its strength when exposed to sunlight for a long period of time.

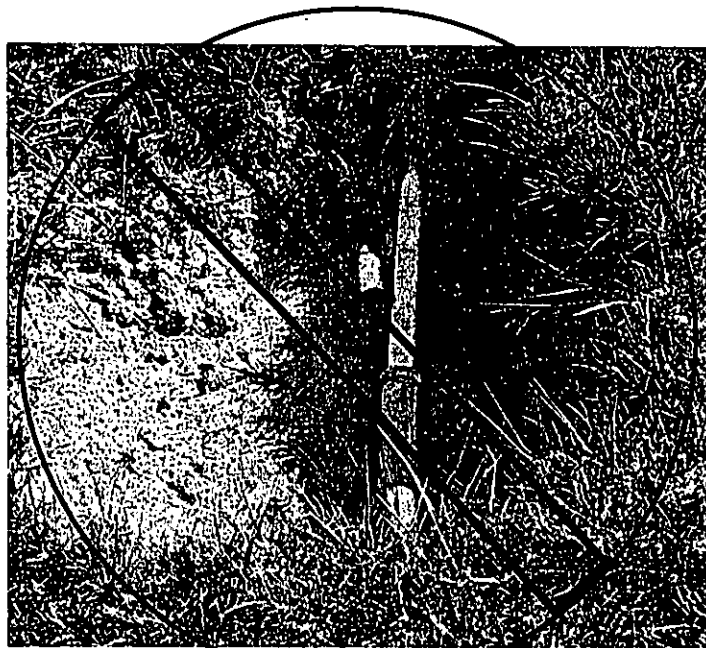
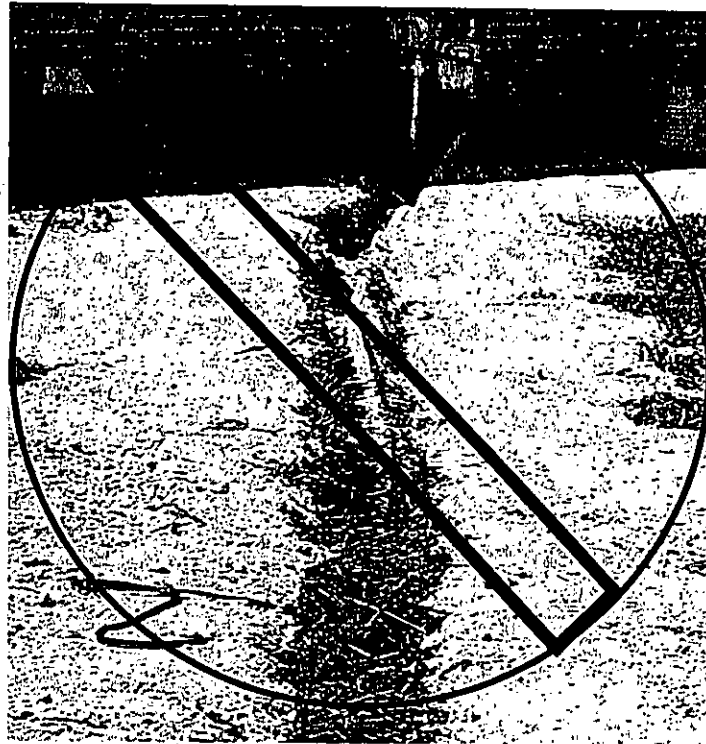
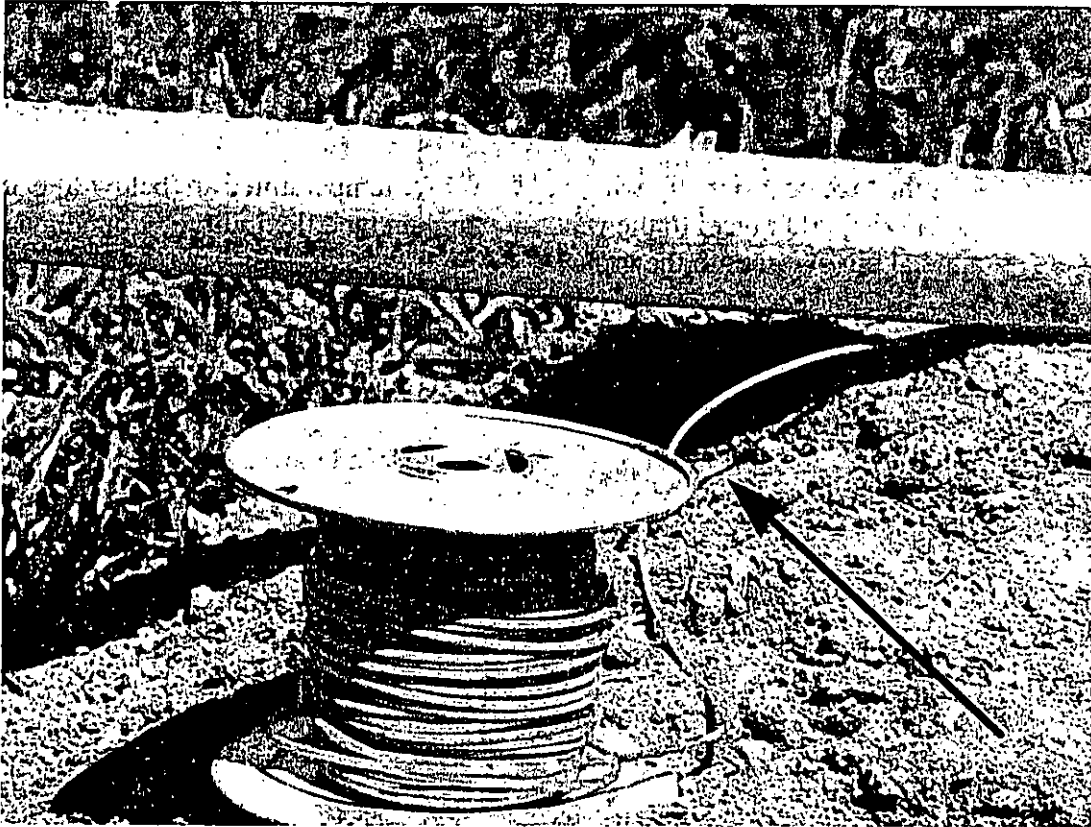


FIGURE VI-13

Below is an example of metallic wire used to help locate buried plastic pipe. Pipe locators can detect metal but not plastic. Therefore, metallic wire must be buried along with the plastic pipe. A pipe locator can then detect the buried metallic wire and the adjacent plastic pipe.



8. Test installed plastic pipe to 100 psig for at least 1 hour.
9. Ensure that plastic pipe is continually supported along its entire length by properly tamped and compacted soil. To prevent any shear or other stress concentrations use external stiffeners at connections to main, valves, meter risers, and other places where compression fittings might be used.
10. In laying of plastic pipe, ensure adequate slack (snaking) in the pipe to prevent pullout due to thermal contraction.
11. Lay plastic pipe and backfill with material that does not contain any large or sharp rocks, broken glass, or other objects that could cut or puncture the pipe. Where such conditions exist, suitable bedding (sand) and backfill must be provided.
12. Take special care to prevent coal tar type coatings or petroleum base tape from contacting the plastic pipe. It can cause plastic pipe to deteriorate.

13. Static electricity can ignite a flammable gas-air atmosphere. When working with plastic pipe of any kind where there is (or there may be) the possibility of a flammable gas-air atmosphere, take the following precautions:

- Use a grounded wet tape conductor wound around, or laid in contact with, the entire section of the exposed piping.
- If gas is already present, wet the pipe starting from the ground end with a very dilute water and detergent solution. Apply tape immediately and leave it in place.
- Wet the tape occasionally with water. Where temperatures are below freezing (0°C/32°F) add glycol to the water to maintain tape flexibility. Ground the tape with a metal pin driven into the ground.
- Do not vent gas using an ungrounded plastic pipe or tubing. Even with grounded metal piping, venting gas with high scale or dust content could generate an electric charge in the gas resulting in an arc from the dusty gas cloud back to the pipe which could ignite the gas. Vent gas only at a downwind location remote from people or flammable material.
  - **NOTE:** Dissipating the static charge buildup with wet rags, a bare copper wire, or other similar techniques may not be as effective as the above procedure. In all cases, use appropriate safety equipment such as flame resistant and static free clothing, breathing apparatus, etc.

14. Ensure that adequate and appropriate maps and records are retained after system installation.

#### REPAIR METHODS: PLASTIC AND METAL

Replacement of gas lines and repair of leaks are highly specialized and potentially hazardous operations. A qualified person must only conduct them.

Leaks in service lines or mains may be repaired by cutting out a short length of pipe containing the leak and replacing it with a new, pretested segment of pipe. Mechanical couplings are commonly used for this purpose (see FIGURE VI-2). Remember that written procedures must be followed for each joint. The procedures can be obtained from the manufacturer of the mechanical coupling. If the operator intends to make the repair with a mechanical coupling, the written procedures must be incorporated into the operations and maintenance plan.

Small leaks in steel service lines or mains, such as those resulting from corrosion pitting, must be repaired with an appropriate leak clamp applied directly over the leak. All bare metal pipe and fittings installed below ground must be properly coated and cathodically protected before backfilling.

If several leaks are found and extensive corrosion has taken place, the most effective solution is to replace the entire length of deteriorated pipe. Normal installation practices must be followed. They include priming and wrapping of all bare metallic piping and fittings, proper grading of lines to the main, cathodic protection, etc.

Leaking metal pipe can often be replaced by inserting PE pipe manufactured according to ASTM D2513 in the existing line and making the appropriate connections at both ends. Again, operators are cautioned that allowance for thermal expansion and contraction must be made at lateral and end connections. Operators unfamiliar with insertion techniques, including proper anchoring and offset connections, should have a qualified contractor perform this work. Some PE pipe manufacturers provide procedures for installation of their products by insertion.

One source of failures in plastic pipe is breaks associated with the transitions between plastic and metal pipes at mechanical fittings. The primary source of the problem is inadequate support of the plastic pipe. It is critical to firmly compact soil under plastic pipe to provide proper support. In practice, however, it is laborious, time consuming, and difficult to achieve adequate compaction under such joints. Further, as the soil settles, stress may build and the insert sleeve will cut through the pipe. For example, an insert sleeve must be used in the plastic pipe to provide proper resistance to the clamping pressure of mechanical fittings. This internal tubular sleeve must extend beyond the end of the mechanical fitting. If the pipe is not properly supported at that point, the end of the insert sleeve may shear off the plastic pipe. This source of failure in plastic pipe can be reduced or eliminated by using a properly designed outer sleeve to prevent stress concentrations at the point where the plastic pipe leaves the mechanical fitting.

The most prevalent cause of breaks or leaks in plastic pipe is "third-party" damage, usually by an excavator breaking or cutting the pipe. Plastic pipe is more vulnerable to such breaks than steel pipe. The lower strength of plastic pipe, however, is not necessarily a disadvantage. For example, if digging equipment hooks and pulls a steel pipe it may not break, but may be pulled loose from a connection at some distance from the digging. The resulting leaks could go undetected for a period of time and may result in a serious incident. Although there is no assurance that the plastic pipe will not also pull out, it is more likely to break at the point of digging, where the break can be detected and repaired. After a leak has been repaired with a coupling or a clamp, a soap-bubble test must be conducted to ensure the leak is repaired.

**ALL SOURCES OF IGNITION SHOULD BE KEPT AWAY FROM THE LEAK REPAIR AREA. OPEN FLAMES SHOULD NEVER BE USED TO DETECT A GAS LEAK OR TO TEST THE ADEQUACY OF A REPAIR JOB.**

## MATERIALS AND EQUIPMENT QUALIFIED FOR USE IN NATURAL GAS SYSTEMS

The pipeline safety regulations list many different materials that are qualified for gas service. The materials and specifications listed in this manual are those most commonly used in natural gas distribution systems. Not all qualified materials or specifications are included in this section. The operator of a small natural gas system is referred to 49 CFR Part 192 for further information.

It is important for an operator to know the material make-up and operating pressure of an existing gas pipeline system. The operator must develop, or have a consultant develop, a list of qualified materials for construction and repair of the system. Installation procedures must be included for each type of material used in the system. This can be accomplished by including or referencing manufacturers' "gas product installation manuals" in the operations and maintenance plan.

When purchasing material for use in a natural gas pipeline system, it is important to check the marking of the material. The marking on the material will help identify whether the material is qualified for gas service. Of course, a natural gas pipeline system consists of both pipe and fittings. Therefore, an operator must select materials that are compatible with each other. This chapter will cover the most common specifications and standards used by manufacturers for pipes, valves, flanges, regulators, and other equipment commonly used in natural gas distribution systems.

### PIPE

Steel and plastic pipe specifications applicable to operators of small natural gas systems are included in this manual. Pipe specifications are listed below. Be sure to check Appendix A of 49 CFR Part 192 for the current specifications and standards.

API 5L - Steel pipe

ASTM A53 - Steel pipe

ASTM D2513 - Thermoplastic pipe and tubing

Operators are cautioned that the actual maximum allowable operating pressure (MAOP) of a new or replacement pipe in a natural gas system is determined by a pressure test performed on the pipeline system by the operator before it is put in service. It is also recommended that threaded pipe not be installed underground.

When purchasing PE plastic pipe, the pipe must be marked ASTM D2513. Plastic pipe with this marking is the only PE pipe suitable for gas service.

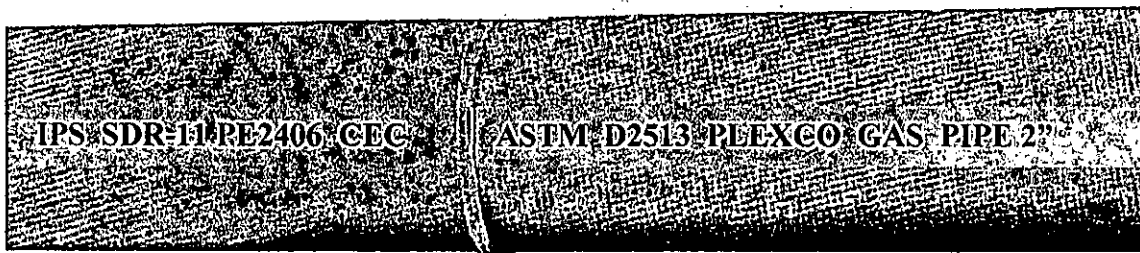
Plastic pipe and tubing should be protected at all times from damage by crushing, piercing, or extended exposure to direct sunlight. As a rule of thumb, never store plastic pipe outdoors for more than six months. It should be placed inside or covered to protect it from exposure to direct

sunlight. It is a good idea to obtain the manufacturer's recommendation on how long the pipe can be exposed to sunlight before it loses physical strength (see 49 CFR §192.321 for more information).

In recent years, the vast majority of natural gas companies and operators of natural gas system have been installing ASTM D2513, PE pipe. Some of the reasons PE pipe is being installed are flexibility, good joining characteristics, durability, ease of installation, and cost. The PE type designations most often used are PE 2406, and PE 3408 (see FIGURE VI-14).

#### FIGURE VI-14

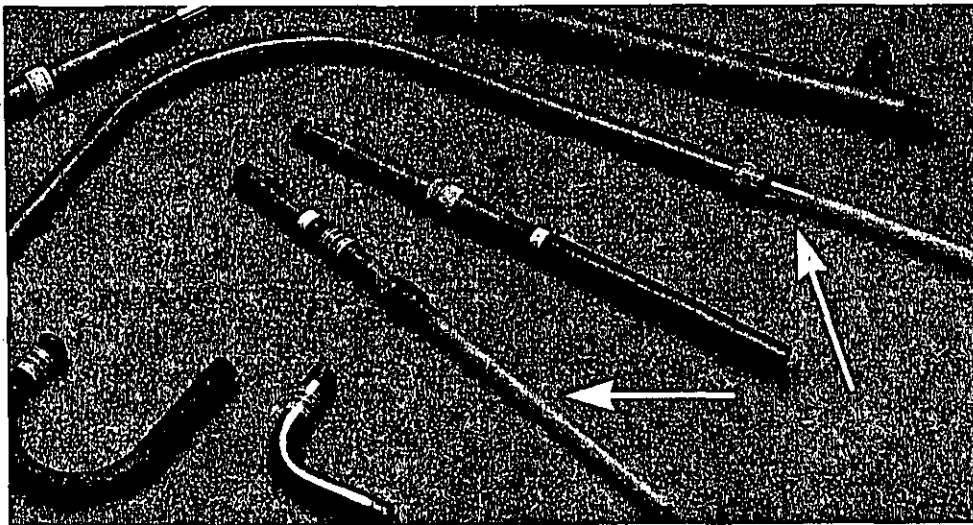
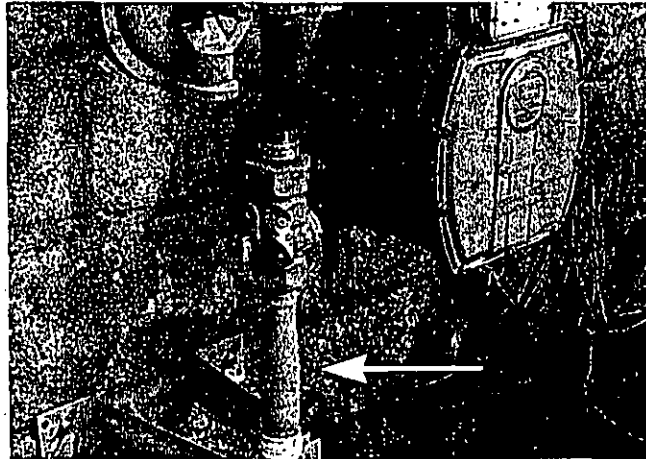
Below is a picture of 4-inch SDR 11 PE pipe manufactured according to ASTM D2513. When using plastic pipe in the underground piping system, make sure it has ASTM D2513 stamped on it.



An anodeless riser is a transition fitting that permits plastic service lines to be brought above ground in compliance with 49 CFR §192.375. The regulations require plastic services to be installed below ground level, except that it may terminate above ground, outside of buildings, if the plastic pipe is protected from deterioration and damage and it is not used to support external loads. Anodeless risers are readily available from various manufacturers and suppliers and are either fully fabricated from the manufacturer, or are field-fabricated by the installer, as is the case with service head adapter risers. Typically, the external protective casing is pre-bent, epoxy coated or galvanized, schedule 40 steel pipe. The plastic gas piping (inside the casing) must extend to an aboveground point for the riser to qualify as anodeless. Otherwise, the riser casing becomes a buried steel pipe gas carrier and is required to comply with Subpart I of 49 CFR Part 192. In most cases there is a grade level or "do not bury" label to indicate the bury depth to the installer. The outlet typically is provided with tapered pipe threads, or in the case of commercial or industrial risers, a bolted flange for attachment to the meter valve. The PE piping inlet, designated as the "pigtail," is provided ready for connection to the service line. This service connection is accomplished either by heat fusion or, if so specified, with a mechanical coupling already attached to the pigtail for additional installation convenience.

FIGURE VI-15

Examples of anodeless service risers. There are many different manufacturers of anodeless risers. The primary advantage of an anodeless riser is that it does not have to be cathodically protected because the outside steel casing is not the gas carrier. The plastic inside the steel casing is the gas carrier. When purchasing anodeless risers, make sure that they meet all DOT requirements. When installing steel risers connected to plastic pipe by a transition fitting, make sure that the steel riser is coated and cathodically protected.



Most PE pipe manufacturers subscribe to the "Standard Dimension Ratio" (SDR) method of rating pressure piping. The SDR is the ratio of pipe diameter to wall thickness. An SDR 11 means the outside diameter (O.D.) of the pipe is eleven times the thickness of the wall.

For high SDR ratios the pipe wall is thin in comparison to the pipe O.D. For low SDR ratios the wall is thick in comparison to the pipe O.D. Given two pipes of the same O.D., the pipe with the thicker wall will be stronger than the one with the thinner wall. High SDR pipe has a low-

pressure rating; low SDR pipe has a high-pressure rating. The operator should check the manufacturer's specific pressure rating for each specific pipe. Do not use pipe with SDR values greater than 11.

PE pipe must be joined by either the heat fusion method (butt, socket, or electrofusion) or by a mechanical coupling. Each joining procedure and each person making joints must be qualified.

For information about local suppliers of plastic gas pipe, contact the local gas utility.

### VALVES

A valve may not be used under operating conditions that exceed the applicable pressure-temperature rating. The valve will be stamped with the maximum working pressure rating (psig). Never operate valves at pressures that exceed their rating. The maximum working ratings are applicable at temperatures from -20°F to 100°F. Metal valves will often be stamped with the symbols "WOG." This means that they are suitable for service for water, oil, or gas. Sometimes just the letter "G" (for gas) appears. The valves must be rated for at least 100 psig.

The manufacturer's name or trademark must be included on a valve. Operators must maintain manufacturers' manuals, which include installation, operation, and maintenance procedures, for each type valve in the gas system. These manuals and procedures should be incorporated or referenced in the operations and maintenance plan.

Plastic valves purchased for gas service must comply with the appropriate industry standard. The valves must be compatible with the plastic pipe used in the natural gas system. It is important that operators buy plastic valves only from suppliers who are knowledgeable about gas piping. Supplier information can be obtained from trade journals, local gas associations (state or regional), or local gas utilities (see enclosed handout).

### FLANGES AND FLANGE ACCESSORIES

Each flange or flange accessory must meet the minimum requirements found in 49 CFR §192.147. Operators must verify that metal flanges purchased for their system meet these requirements. This can be done by checking the markings on the flange. The markings are similar to those on the valves.

## REGULATORS AND OVERPRESSURE PROTECTION EQUIPMENT

There are many different manufacturers and models of gas regulators and overpressure equipment (relief valves) for use in gas pipeline systems.

Regulators and overpressure protection equipment must be sized to ensure that overpressure or low-pressure conditions do not occur in the gas system. Manufacturers of gas regulators and relief valves have manuals that contain formulas and charts for each of their models or types of equipment. These formulas and charts are necessary to properly size regulators and relief valves. A qualified person must install the equipment. Operators who do not have a technical background should rely on a consultant or the equipment manufacturer representative to size the equipment. Check with the state for additional local requirements. See the enclosed handout for further information.

It is important to obtain the manufacturer's operation and maintenance instructions for each type of regulator and relief valve used in the gas pipeline system. The instructions must be incorporated into the operations and maintenance plan. CHAPTER II is a primer on basic concepts on pressure regulation, regulators, and relief devices:

## OTHER EQUIPMENT

A natural gas operator may need additional equipment to operate a natural gas system. This additional equipment may include:

- pipe-to-soil meters;
- pipe locators;
- gas leak detection equipment;
- industry publications.

An illustration of a pipe-to-soil meter is in CHAPTER III. Additional information on gas leak detection equipment and pipe locators is found in CHAPTER IV. The local gas utility or gas association is a good source of assistance.

## WELDING REQUIREMENTS

How can an operator determine whether pipeline welding is performed as required?

1. Welding must be performed in accordance with written welding procedures qualified to produce acceptable welds. For typical pipeline welding, standard API 1104 is most often relied on. The welding procedures should include:
  - a. Records of the complete results of the procedural qualification test
  - b. Procedural specification
    - (1) Identifying the process
    - (2) Identifying the materials
    - (3) Identifying the wall thickness groups
    - (4) Identifying the pipe diameter groups
    - (5) Showing a joint design sketch
    - (6) Designating filler metal and number of beads
    - (7) Designating electrical characteristics
    - (8) Designating flame characteristics
    - (9) Designating positions or roll welding
    - (10) Designating direction of welding
    - (11) Designating maximum time lapse between passes
    - (12) Designating type of line-up clamp and removal criteria
    - (13) Designating type of cleaning tool used
    - (14) Specifying preheat and post heat practices
    - (15) Designating composition of gas and range of flow rate
    - (16) Designating type and size of shielding flux
    - (17) Designating range of speed of travel for each pass
  - c. Essential variables  
Most changes in b. require requalification of the welding procedure. (Refer to API 1104, paragraph 2.4.)
  - d. Welding and testing of test joint
    - (1) Preparation of specimen
    - (2) Destructive tests - butt welds
      - (a) Tensile strength test
      - (b) Nick break test
      - (c) Root and face bend test
      - (d) Side bend test
    - (3) Destructive test - fillet welds: Break in weld as specified
2. Welders who are qualified for the welding procedure to be used must perform welding.
  - a. The welder shall be qualified under one of the applicable requirements specified.
    - (1) Transmission pipelines
      - (a) API 1104, Section 3; or
      - (b) ASME Boiler and Pressure Vessel Code, Section IX
    - (2) Distribution pipeline
      - (a) API 1104, Section 3;

- (b) ASME Boiler and Pressure Vessel Code, Section IX; or
- (c) 49 CFR Part 192, Appendix C, Section I (not acceptable for service line to main connection welding).
- (3) Service line to main connections
  - (a) API 1104, Section 3;
  - (b) ASME Boiler and Pressure Vessel Code, Section IX; or
  - (c) 49 CFR Part 192, Appendix C, Sections I and II.
- b. Welder qualification under API 1104, Section 3.
  - (1) Perform qualification test as specified in the written welding procedure in the presence of the company's representative.
  - (2) Essential variables (certain changes require re-qualification).
    - (a) For single qualification refer to API 1104, paragraph 3.11; or
    - (b) For multiple qualification refer to API 1104, paragraph 3.21.
  - (3) Welding and testing of test joint
    - (a) Preparation of specimen(s)
    - (b) Visual examination
    - (c) Destructive test - butt welds
      - Determine if all or part of these tests is required:
      - 1 Tensile strength test (*optional*)
      - 2 Nick break test
      - 3 Root and face bend test
      - 4 Side bend test
    - (d) Destructive tests - fillet welds: Break in weld as specified.
    - (e) Visual inspection

NOTE: Nondestructive radiographic inspection of butt welds only can be done in lieu of (3)(c) above. This is the operator's option. The standards of acceptability for radiographic inspection are specified in API 1104, paragraph 6.0.

- (4) Keep the following records:
  - (a) Detailed test results for each welder.
  - (b) List of qualified welders and the procedures(s) for which they are qualified.
- c. Welder qualification under 49 CFR Part 192, Appendix C, Section I
  - (1) Perform qualification test on pipe 12 inches or less in diameter
  - (2) Use position welding
  - (3) Preparation must conform to written welding procedure
  - (4) Destructive test. - root bend test
  - (5) Visually inspect
  - (6) Keep the following records:
    - (a) Detailed test results for each welder
    - (b) List of qualified welders under this procedure
- d. Welder qualification under of 49 CFR Part 192, Appendix C, Sections I and II
  - (1) Perform c. above
  - (2) Weld service line connection fitting to a pipe typical of the main using similar position as one would in actual production welding
  - (3) Destructive test - break, or attempt to break, the fitting off the run pipe

- (4) Keep the following records:
  - (a) Detailed test results for each welder
  - (b) List of qualified welders under this procedure
- e. Remain qualified under API 1104, Section 3 or ASME Boiler and Pressure Vessel Code, Section IX, if:
  - (1) Within the preceding six months, welder has welded with the particular welding process (either test or production welding is acceptable), and welder has made a weld and had it tested satisfactorily either destructively or nondestructively. (Refer to 2b(3) for required procedure.)
- f. Remain qualified under either 49 CFR Part 192, Appendix C, Section I or II, if:
  - (1) Within the preceding 7½ months but at least twice each year, welder has had one production weld cut out, tested, and found acceptable in accordance with the initial qualification test; or,

**NOTE:** Welders who work only on service lines 2 inches or smaller in diameter may be tested in each 6-month period under 49 CFR Part 192, Section III, Appendix C in lieu of f(1) above, but at the same intervals.

- (2) Within the preceding 15 months, but at least once each year, welder has requalified under 49 CFR Part 192 Appendix C

### 3. Production welding

- a. Use a welder qualified in a qualified welding procedure.
- b. The following items should be part of the written welding procedure:
  - (1) Weather protection - 49 CFR §192.231
  - (2) Preparation - 49 CFR §192.235
  - (3) Visual Inspection - 49 CFR §192.241
  - (4) Nondestructive Testing (under specified conditions) - 49 CFR §192.243. Must meet standards of acceptability in API 1104, Section 6.
- c. Miter joint restrictions  
The use of miter joints is restricted as follows:
  - (1) If MAOP produces a hoop stress of 30 percent or more SMYS, the joint cannot deflect the pipe more than 3 degrees.
  - (2) If MAOP produces a hoop stress of more than 10 percent SMYS but less than 30 percent, the joint cannot deflect the pipe more than 12.5 degrees and must have at least one pipe diameter separation from another miter joint.
  - (3) If MAOP produces a hoop stress of 10 percent of SMYS or less, the joint cannot deflect the pipe more than 90 degrees.
- d. Repair or removal of defect requirements is as follows:
  - (1) Remove or repair all welds that fail to pass the nondestructive test requirements (standards of acceptability in API 1104, Section 6).
  - (2) Remove all welds that contain cracks that are more than 8 percent of the weld length.
  - (3) Repairs must have the defect removed down to clean metal and the segment to be repaired must be preheated if conditions exist which would adversely affect the quality of the weld repair. Inspect the repaired weld.

- (4) Repair of a crack, or any defect in a previously repaired area, must be in accordance with written weld repair procedures that have been qualified under this guidance manual.

## PLASTIC PIPE INSTALLATION CONCERNS – BRITTLE LIKE FRACTURES

FIGURES VI-16 through VI-19 illustrate plastic service line connections to gas mains. There have been accidents due to the failure of the plastic pipe in certain types of installations. These installations are associated with older polyethylene pipe (1960s through early 1980s), which may be vulnerable to fractures and brittle-like cracking. The key areas of concern are where the pipe may not be properly supported in a transition area, which may cause excessive bending of the pipe.

The transition area is where the plastic pipe is connected to a fitting, valve, or riser. As the earth settles, inadequately supported plastic pipe may be subjected to high bending stresses and possible failure. Figures VI-16 through VI-19 show the use of protective sleeves in the transition areas. Protective sleeves, along with attention to adequate backfill and support, can help to distribute excessive stresses. The design of a protective sleeve is dependent on type of soil, size of pipe, composition of the backfill, and size of the access trench or bell hole. Therefore, it is imperative that pipeline operators review the specific sleeving and support instructions provided by the pipe manufacturer.

Excessive bending of pipe in non-transition areas can also result in excessive stresses that can lead to plastic pipe failure. If the pipe is installed with very tight bends, the pipe wall can be stressed beyond manufacturers recommendations. This can result in brittle-like fracture of the pipe wall. Every manufacturer has a recommended maximum bending radius for each type and size of pipe. The maximum bending radius is reduced for pipe spans that contain a fusion or mechanical joint. Therefore, it is imperative that pipeline operators review the maximum bending limits for each type of pipe.

Backfill material should consist of sand or native soil containing no sharp rocks or other foreign objects. Backfill material containing sharp rocks has caused several accidents. Proper backfill and support are essential to the installation and safe, long-term performance of plastic pipe.

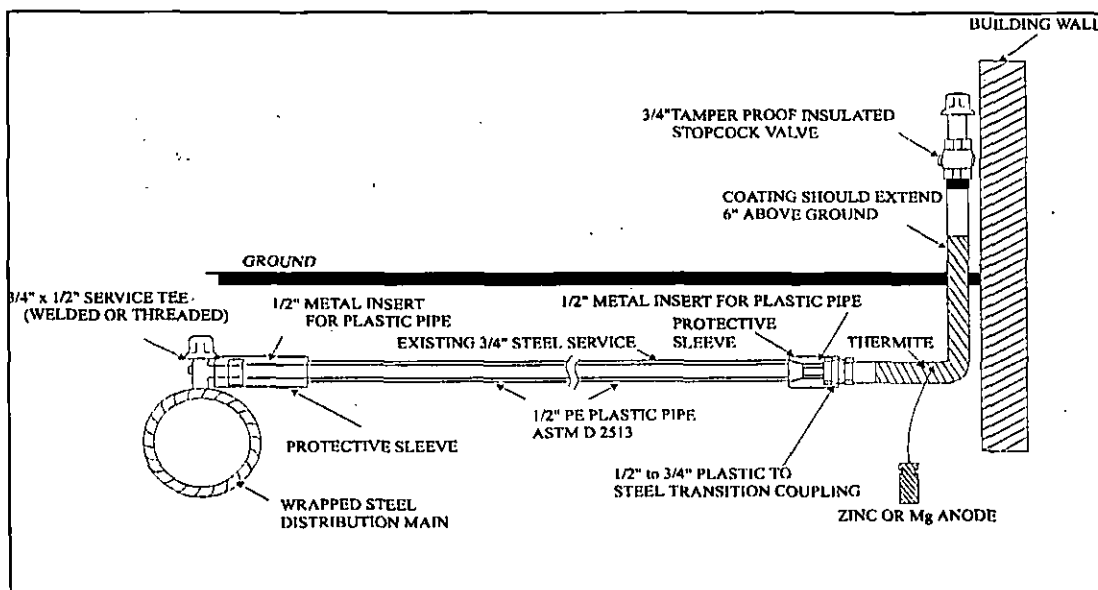
**ADDENDUM 1 – INSERT ON PAGE VI-28**  
**APPROVED BY NAPSRS – JUNE 26, 2003**

## COMMON CONSTRUCTION PRACTICES

The following (FIGURES VI-16 AND VI-17) illustrate a steel to plastic pipe connection using a mechanical coupling. There are other sizes of connections. Refer to specific manufacturer's instructions for the proper couplings and coupling procedures.

FIGURE VI-16

Below is an example of a 1/2" plastic pipe inserted into a 3/4" existing service line (for illustration purposes only).



Elevation

### ALTERNATE SERVICE CONNECTION

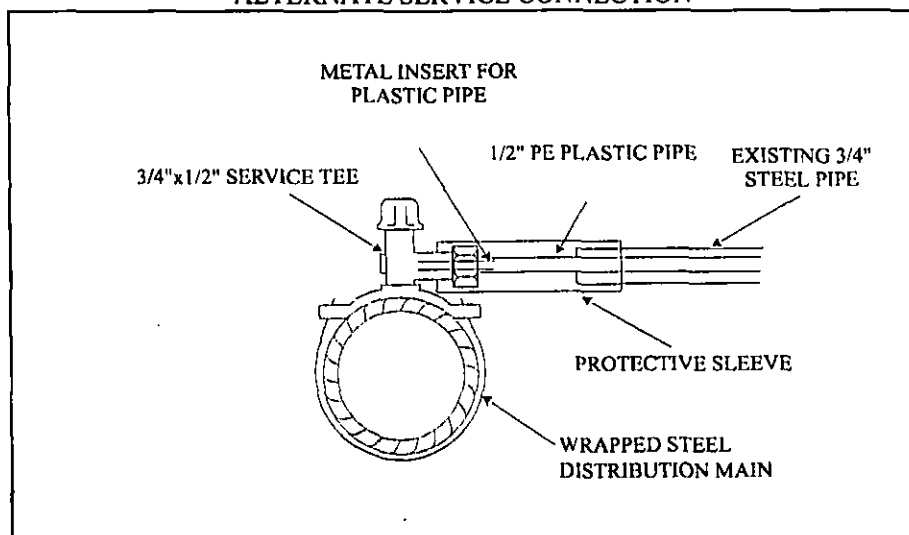
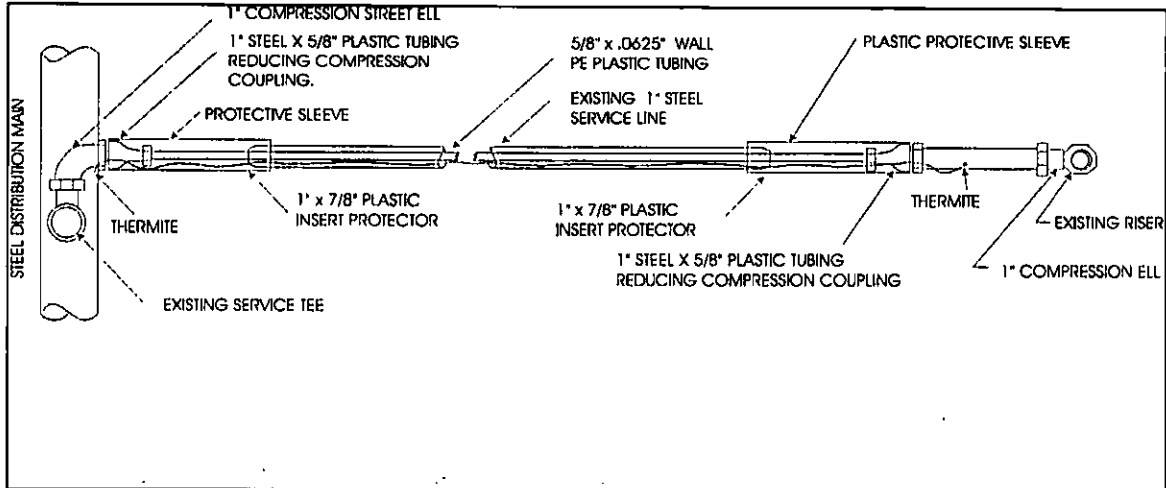
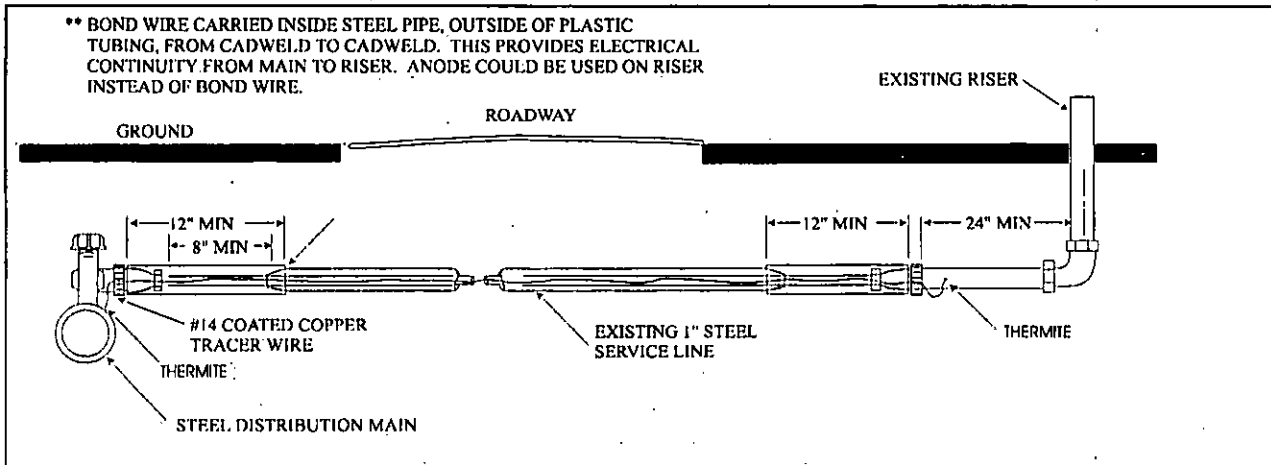


FIGURE VI-17

Below is an example of a 5/8" PE plastic tubing inserted into a existing 1" metallic line (for illustration purposes only).



Plan



Elevation

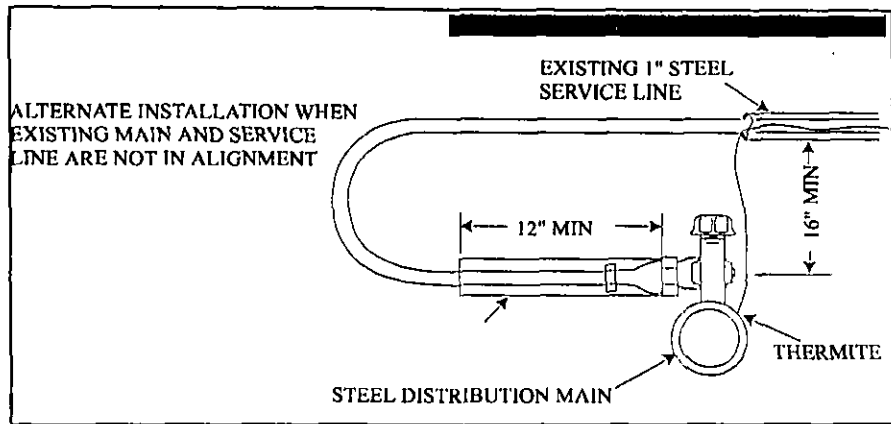
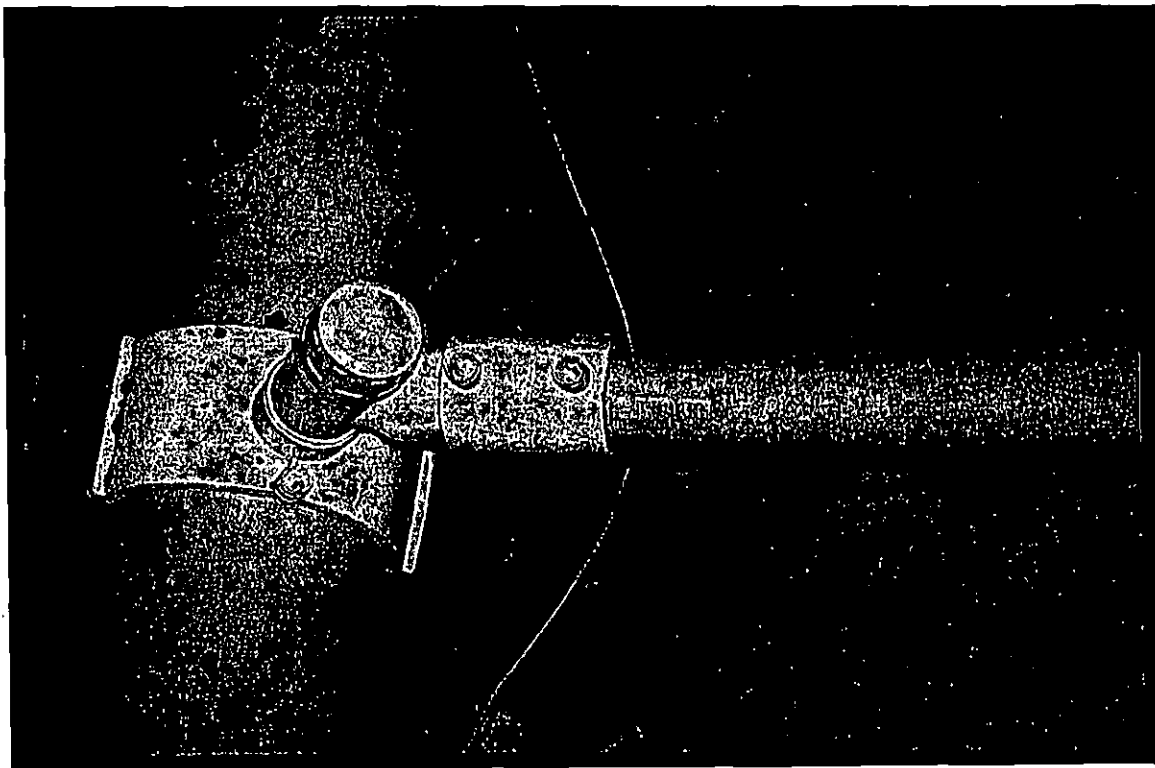


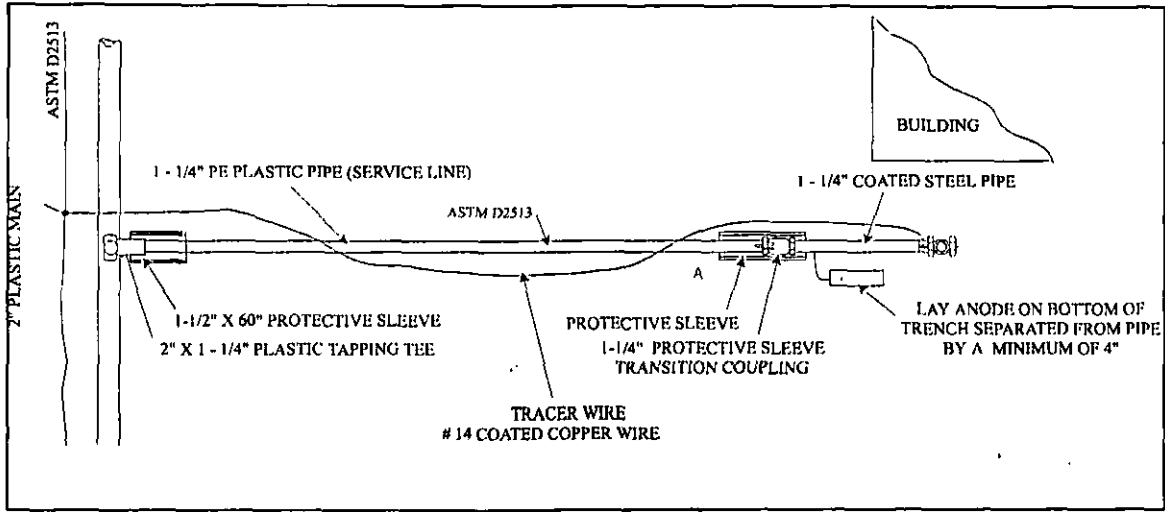
FIGURE VI-18

Below is an example of a 1/2" plastic pipe inserted into an electrofusion coupling which is electrofused onto a 2" electrofusion saddle fitting.

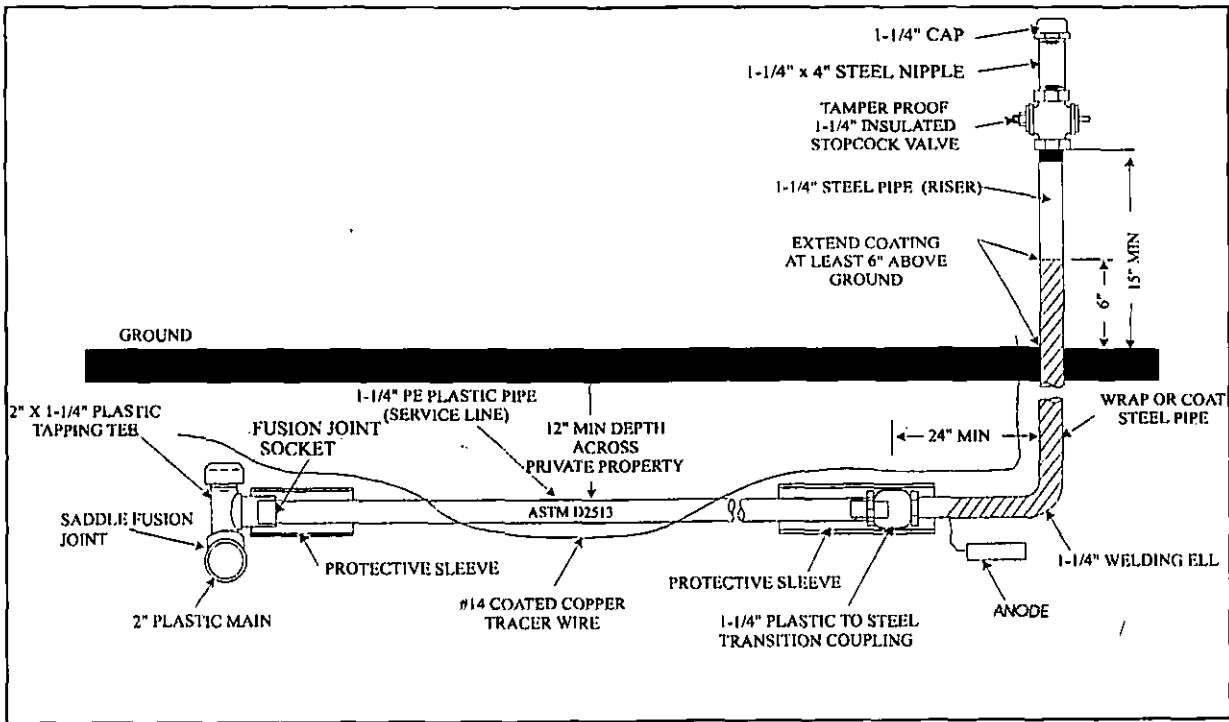


**FIGURE VI-18A**

An example of a 1 1/4" plastic service line from a 2" PE plastic main (for illustration purposes only).



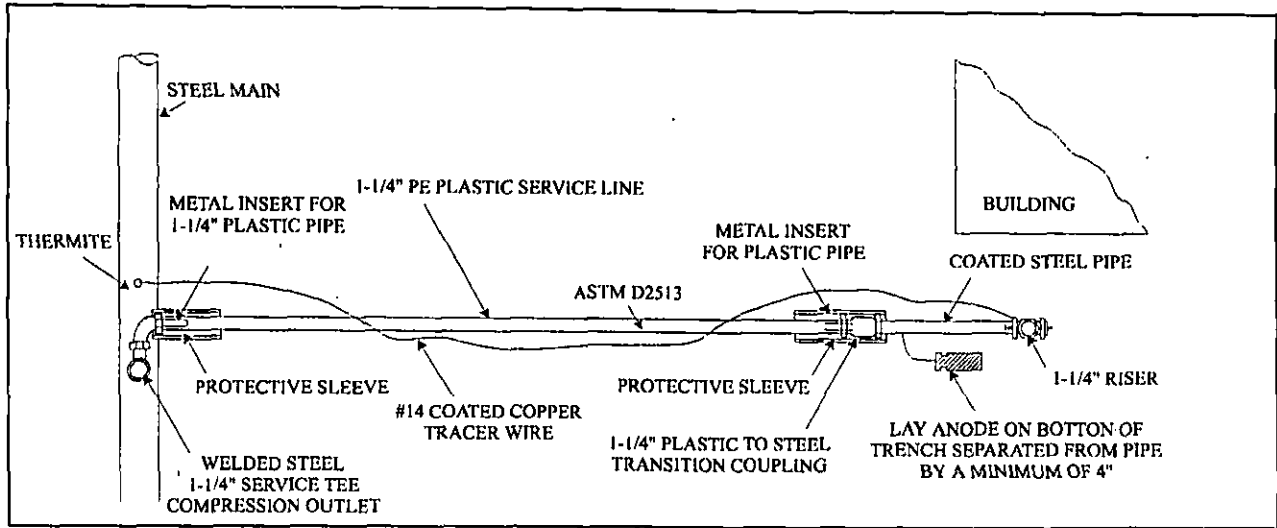
Plan



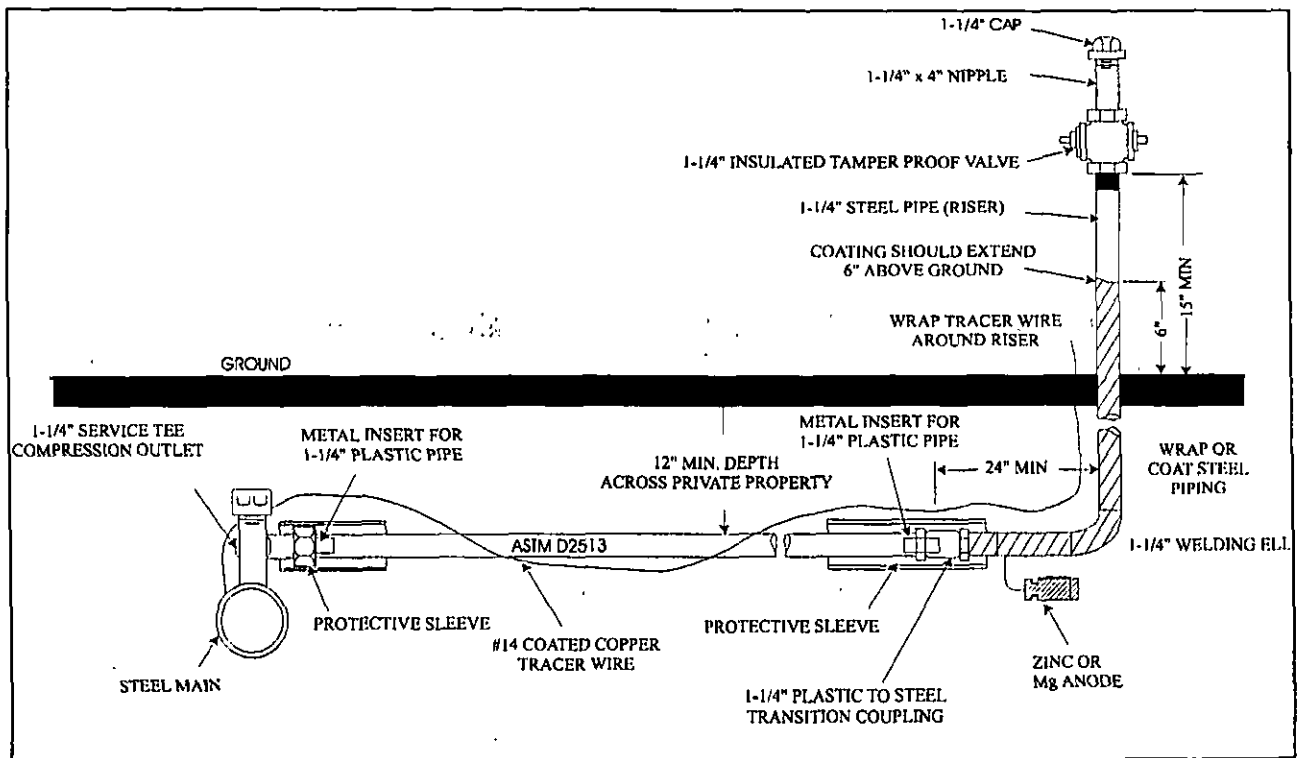
Elevation

FIGURE VI-19

An example of a 1 1/4" PE plastic service line from a steel main (for illustration purposes only).



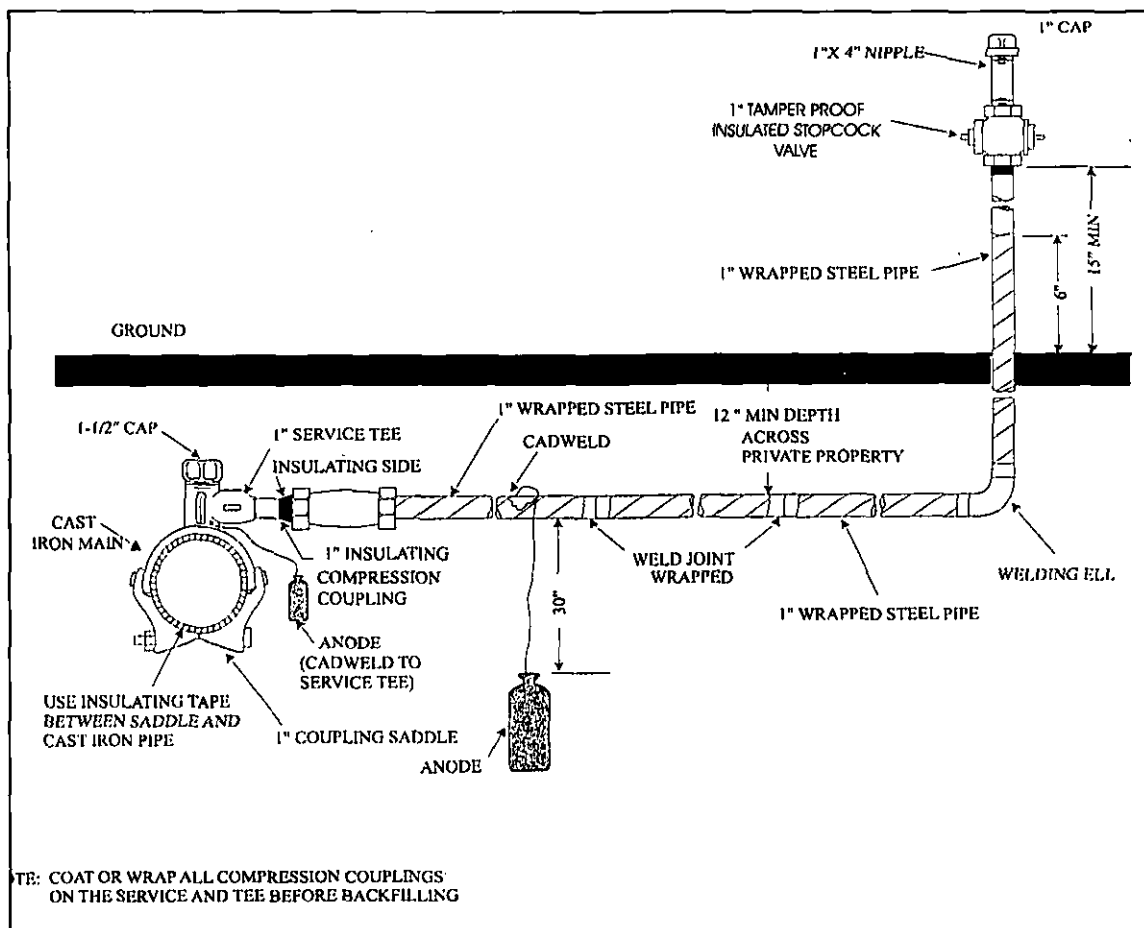
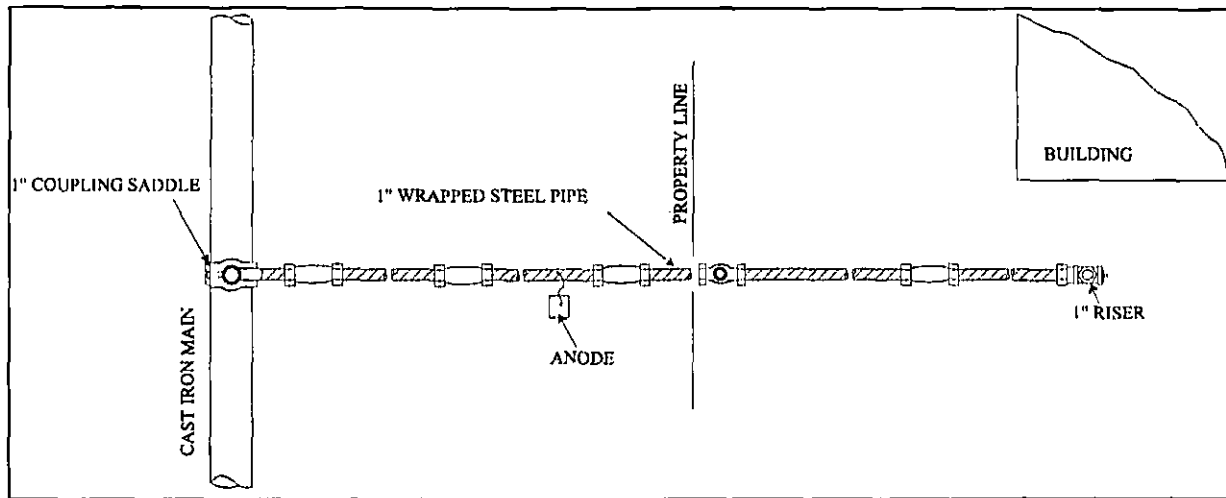
Plan



Elevation

**FIGURE VI-20**

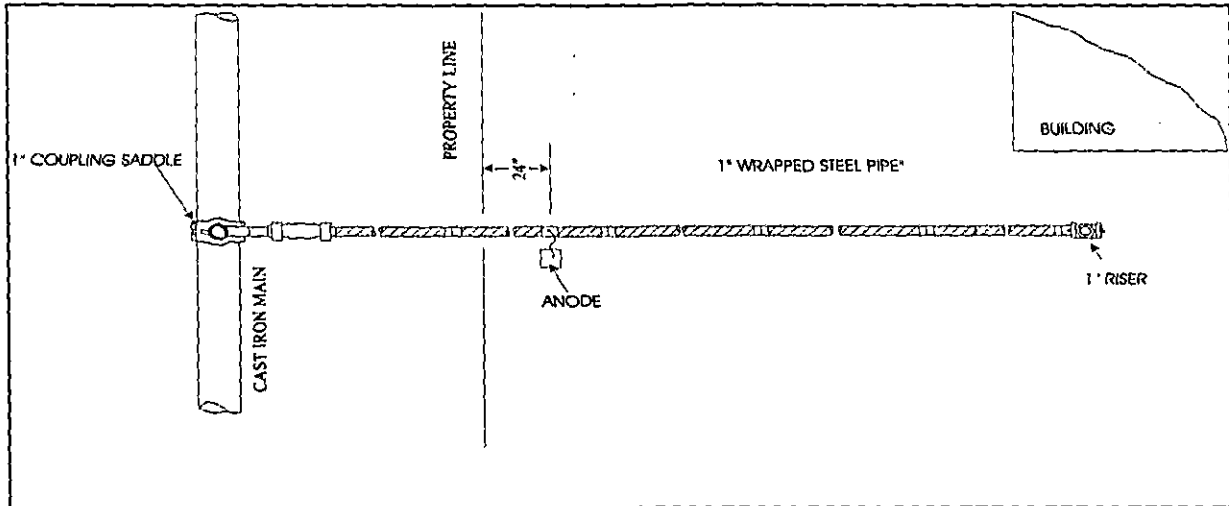
An example of non-welded 1" service line from a cast iron main (for illustration purposes only).



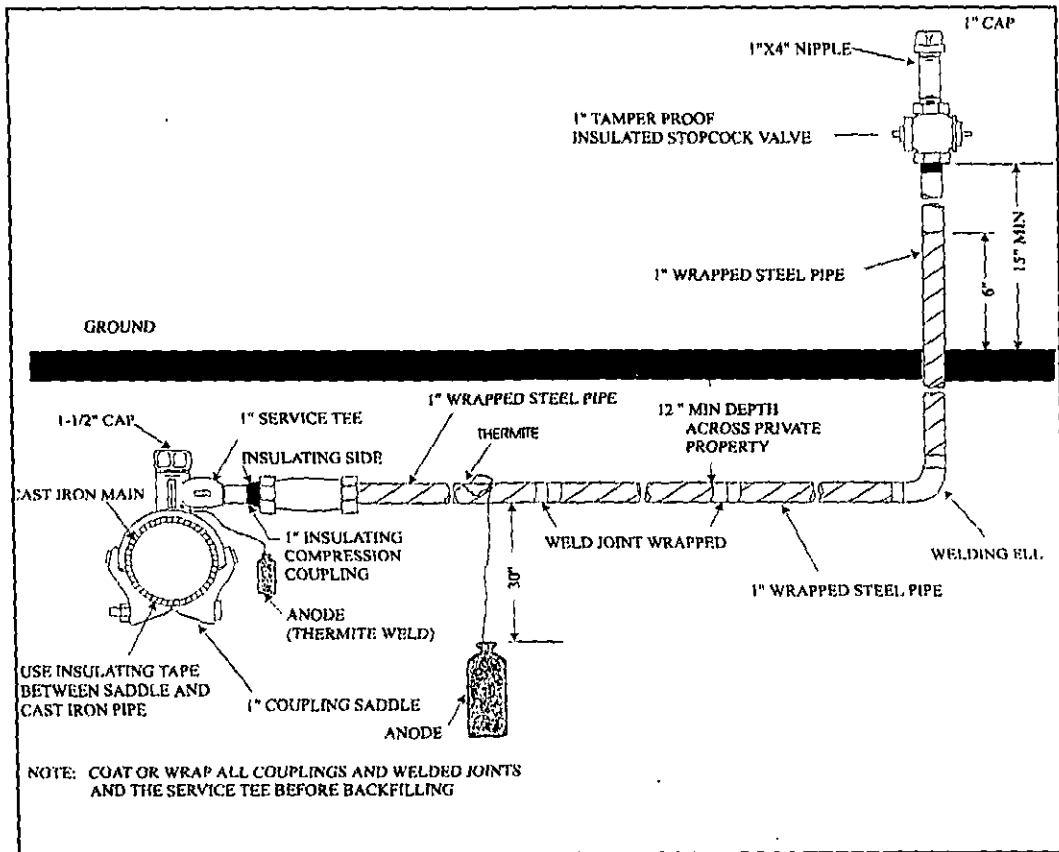
Elevation

**Figure VI-21**

An example of a welded 1" steel service-line from a cast iron main (for illustration purposes only).



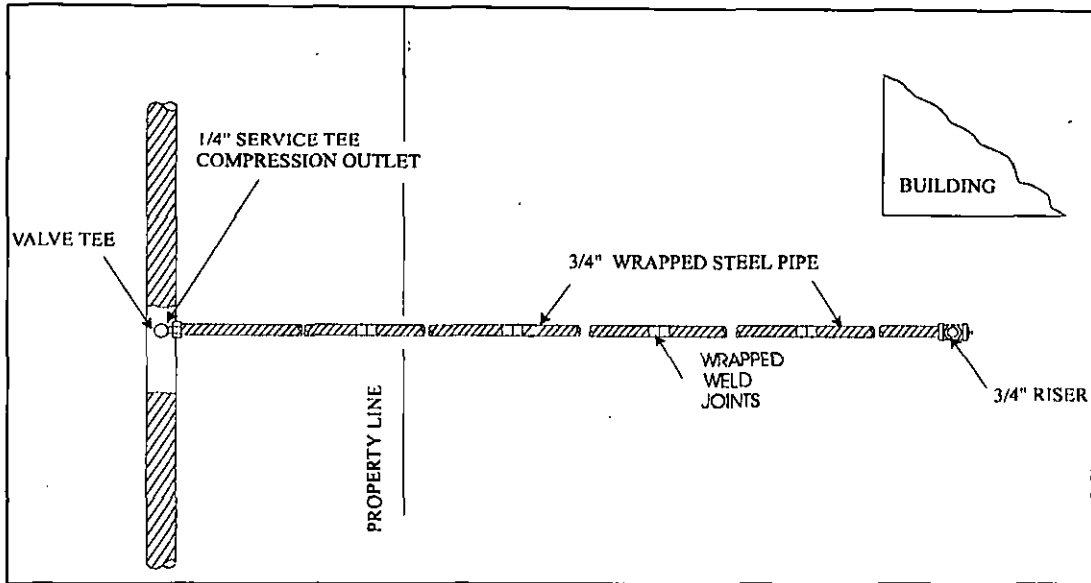
**Plan**



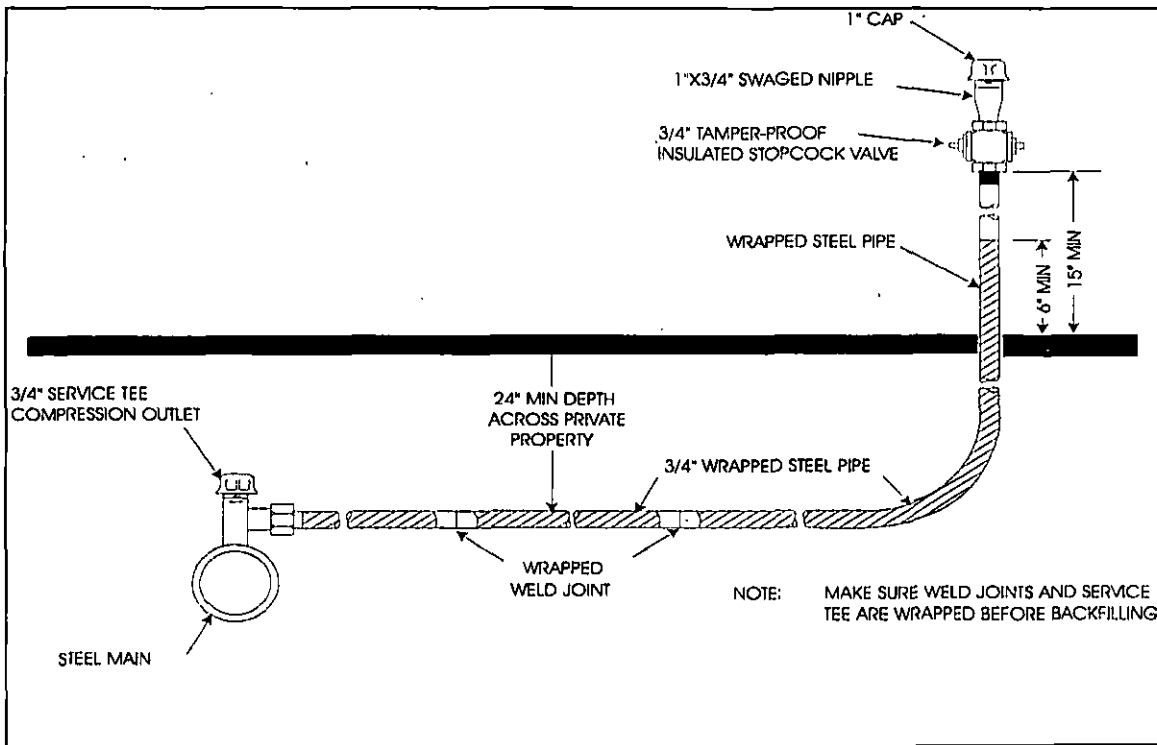
**Elevation**

FIGURE VI-22

Below is an example of a welded  $\frac{3}{4}$ " service line from a steel main (for illustration purposes only).



Plan



Elevation

The following two pages (FIGURES VI-23A AND 23B) illustrate a steel to plastic connection using a coupling. There are other sizes of connections. Refer to specific manufacture's instructions for the proper couplings and coupling procedures.

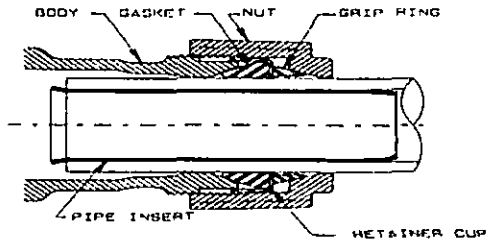
FIGURE VI-23A

# DRESSER®

## INSTALLATION INSTRUCTIONS

### Style 90 "Universal" Couplings & Fittings

For P.E. to P.E., P.E. to Steel & Steel to Steel  
(For use on polyethylene pipe listed in ASTM D2513)



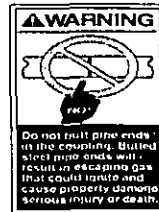
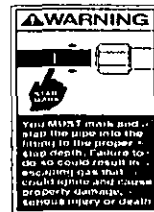
1. Clean steel pipe ends to bare metal removing oil, dirt, loose scale, and rust. Polyethylene pipe must be free of dirt, longitudinal scratches, grooves & burrs for a distance of 4" when using 5" long bodies or fittings & 7" on 10" long bodies.
2. On all P. E. pipe ends, the recommended Dresser Insert stiffener must be installed. Before inserting in pipe end, each insert should be checked to ensure that the SDR indicated on the branding corresponds to the SDR of the pipe being used.
3. Remove plastic identification plug from nut, then loosen nut (DO NOT DISASSEMBLE) and check inside of the fitting to assure gasket and grip ring are loose and free of dirt or foreign matter.

4. Apply soap-water to the gaskets, only when installing on steel pipe (ethylene glycol may be added in freezing weather).
5. Mark each pipe 2" from pipe end. Stab the pipe end(s) into the fitting or coupling until the mark on the pipe is even with the edge of the nut or inside the nut.

**CAUTION:** A minimum of 1/2" is required between the pipe ends or pipe end and pipe stop in fitting when connecting steel pipe(s).

Nominal Pipe Size (I.D.)	Wrench Size
3/4"	14"
1"	18"
1-1/4"	18"
1-1/2"	24"
2"	24"

6. Tighten nut(s) independently while holding the body from rotating with a 100 lb. minimum pull on the recommended wrench size.



#### Product Rating For Couplings With Same Pipe Diameter On Both Ends (For Reducing Sizes, The Rating For The Smallest Diameter Applies)

Pipe Size		Max. Sealing Pressure (See Note 2)	Max. Steel Pipe Pullout Resistance	Polyethylene Pipe Pullout Resistance Up To The Max. Wall Listed in Table Meets Or Exceeds The Requirements Specified in D.O.T. 192.283(b) (See Note 1)	
				Type 2306	Type 3406/3408
3/4"	1.050	150 P.S.I.	1300 lbs.	SDR 11	Sch. 40
1"	1.315	150 P.S.I.	2100 lbs.	SDR 11	SDR 9.3
1-1/4"	1.660	150 P.S.I.	3200 lbs.	SDR 10	SDR 9.3
1-1/2"	1.900	150 P.S.I.	3700 lbs.	—	SDR 11
2"	2.375	150 P.S.I.	6600 lbs.	SDR 9.3	SDR 9.3

NOTE 1 - Pullout resistance is based on using Dresser reinforcing pipe inserts.  
NOTE 2 - Unless noted on body.



DMD DIVISION, DRESSER INDUSTRIES, INC.  
41 FISHER AVENUE  
BRADFORD, PENNSYLVANIA 16701

## CHAPTER VII

### PROPER LOCATION AND DESIGN OF CUSTOMER METER AND REGULATOR SETS

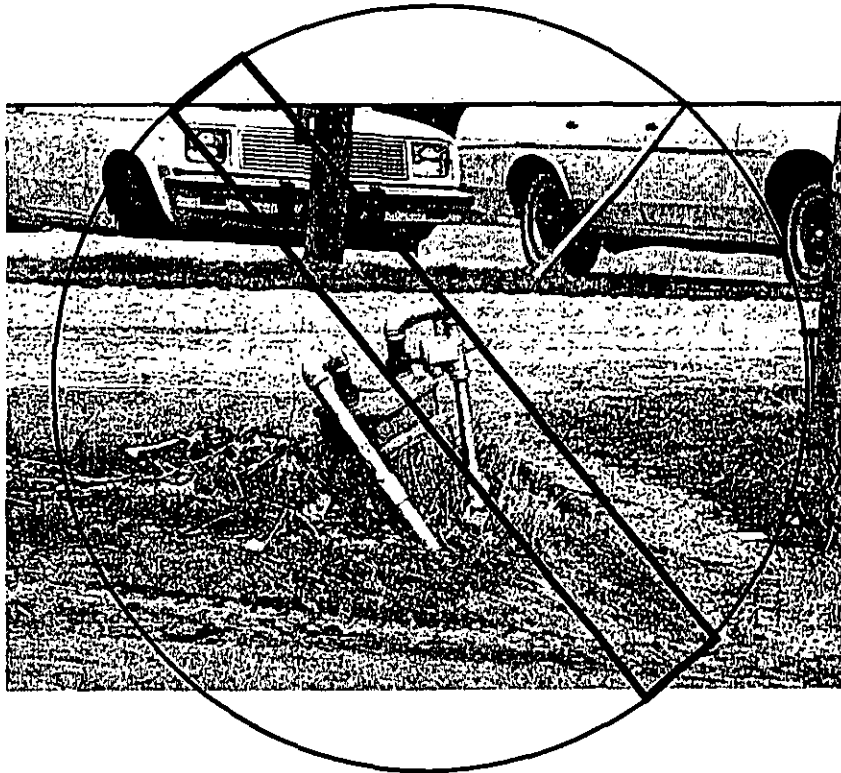
Before locating customer meters and regulators, three points must be considered: accessibility, protection of meter sets from damage, and protection of people from release of gas at the meter set.

#### CUSTOMER METERS AND REGULATORS: LOCATION

Install meters and service regulators in a readily accessible location. Protect the meters and regulators from corrosion and other damage. Whenever a vehicle could damage meter sets, a suitable barricade must be installed. Always ensure that the meter sets are properly supported. Install meters outside wherever possible (see FIGURE VII-1).

#### FIGURE VII-1

This meter may be readily accessible, but is neither protected from outside damage nor properly supported.



Service regulators installed inside a building must be placed as close as practical to the point of service entering the building. The operator must vent the regulator to the outside.

Meters installed inside a building must be located in a ventilated place. A meter must be more than 3 feet from any source of ignition or any source of heat that might damage the meter.

It is best to locate the upstream regulator (in a series) outside the building. However, the operator may locate regulators in a separate metering or regulating building.

### **CUSTOMER METERS AND REGULATORS: PROTECTION FROM DAMAGE**

Protection from vacuum or backpressure. If customer equipment might create either a vacuum or a backpressure, protection devices must be installed on the gas system.

Service regulator vents and relief vents. The outside terminal of each service regulator vent and relief vent must be:

- rain, snow, ice and insect resistant;
- located where gas from the vent can escape freely into the atmosphere (vent it 3 feet or more away from any opening into the building);
- protected from water damage in areas where flooding may occur (put it where it will not be underwater in a flood).

The meters and regulators must be installed to minimize stresses on connecting piping.

Each pit or vault in a road, driveway, or parking area that houses a customer's meter or regulator must be able to support the vehicle traffic that could use that road, driveway, or parking area.

### **CUSTOMER METERS INSTALLATIONS: OPERATING PRESSURE**

A meter may not be used at a pressure that is more than 67 percent of the manufacturer's shell test pressure (0.67 x shell test pressure).

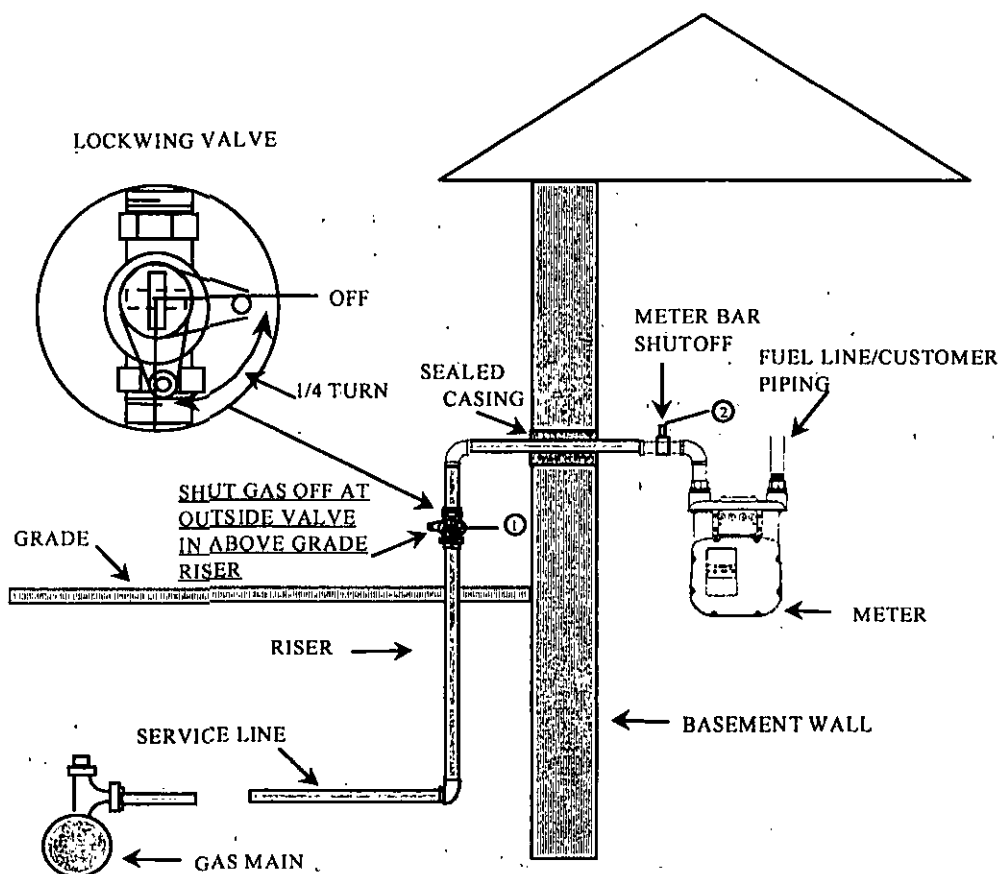
The operator must ensure that each newly installed meter has been tested to a minimum of 10 psig.

## SERVICE LINES: LOCATION OF VALVES

- Relation to regulator or meter. Each service line valve must be installed upstream of the regulator. If there is no regulator, install the valve upstream of the meter (see FIGURES VII-2 through VII-5).
- Outside valves. Each service line must have a shut-off valve in a readily accessible location outside of the building (see FIGURE VII-2).
- Underground valves. Each underground service line valve must be located in a covered, durable curb box or standpipe that allows ready operation of the valve. **The box or standpipe must not put stress on the service line** (see FIGURES VII-3 and VII-4).

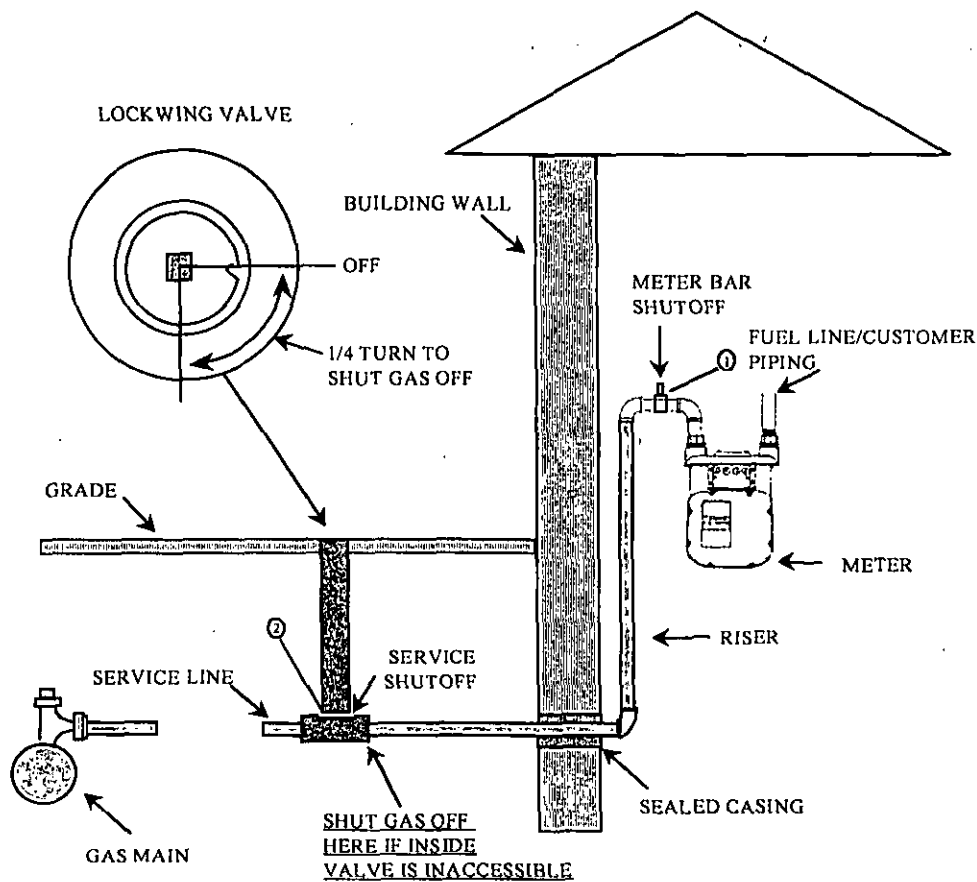
Services should not be installed under buildings or mobile homes. If a service is installed under a building, it must be encased in a gas-tight conduit. This conduit must vent to the outside at a point where gas would not be a hazard and must terminate aboveground in a rain, snow, ice and insect resistant fitting.

FIGURE VII-2



This is a typical low-pressure service (pressure in main and service are essentially the same as customer utilization pressure). Note that this service can be shut off at either (1) or (2) as shown on drawing. This service would be in compliance with 49 CFR 192.365. The valve at either points (1) or (2) must be designed so that it can be locked in a closed position. Depending on the type of valve, more than a quarter turn may be required to shut off gas.

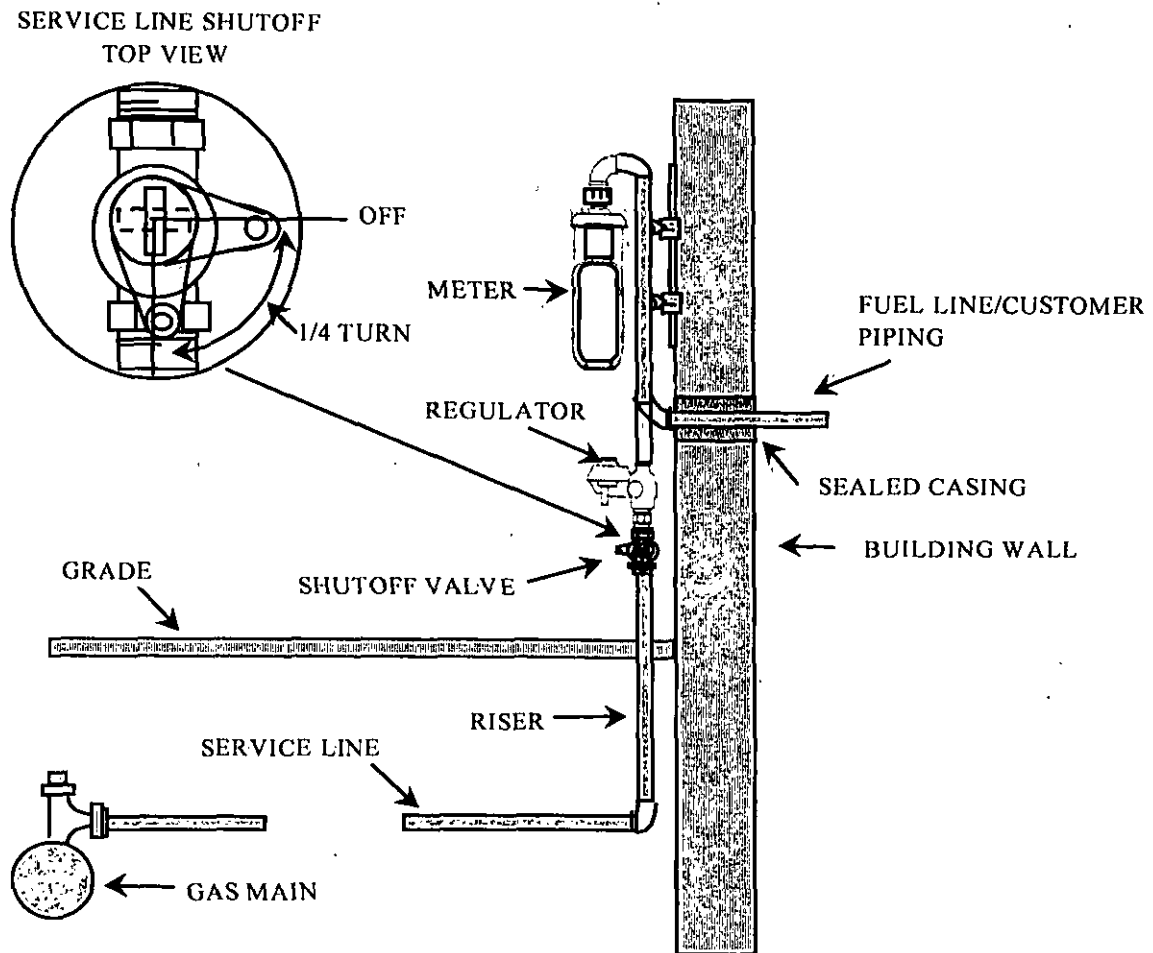
FIGURE VII-3



Note that this service can be shut-off at either points (1) or (2). The valve at point (1) must be designed so that it can be locked in a closed position. The valve at point (2) is installed in a valve box. Depending on the type of valve, more than a quarter turn may be required to shut-off gas.



FIGURE VII-5



Note that the shutoff valve is before the regulator and meter. This valve must be designed so that it can be locked in the closed position. Depending on the type of valve, more than a quarter turn may be required to shut off gas.

## COMMON PROBLEMS AT SERVICE RISER AND HOUSE REGULATORS

- Regulator vandalism or damage. This can be very hazardous. If the regulator fails to function for any reason, high-pressure gas may enter the appliances. Tall flames at the burner or escape of gas could cause a fire or explosion.
- Obstructed vents. The vent on the regulator should be free of any obstructions. A wire screen installed at the vent should prevent the accumulation of dirt, the intentional insertion of foreign objects by children, or the build up of insect nests (e.g., wasp nests). If the screen is removed, a new one must be inserted in its place. A non-functioning vent could cause regulator failure and present a serious fire hazard. The vent should be away from windows and air intakes and protected from the elements.
- Tenants move out. The valve on the meter riser should be equipped with a locking device to be controlled by authorized personnel only. When tenants move out, the gas must be shut off and the valve locked until new tenants move in. The locking device on the shutoff valve also allows the repair of appliances without the gas being accidentally turned on.
- Riser misuse. The tenants or customers should not be allowed to use the riser and its components for other purposes. Never use the riser as an anchor for laundry lines, plant supports, or bicycle racks (see CHAPTER III, FIGURE 17).
- Corrosion. Check for corrosion on the service riser at ground level (see CHAPTER III, FIGURE 24).
- Flex Lines. Flex Lines should be UL approved and must be installed aboveground.

## CHAPTER VIII

### PLANS AND REPORTS REQUIRED BY THE FEDERAL GOVERNMENT

#### PLANS REQUIRED BY THE FEDERAL GOVERNMENT

All operators of natural gas systems are required to maintain plans for operations and maintenance and emergency response activities. Most operators comply with this requirement by developing and maintaining a manual that incorporates both plans. The manual must be prepared before operations of a natural gas system commence and must be reviewed and updated annually. The manual must be kept at locations where operations and maintenance activities are conducted. This manual fulfills the requirements of 49 CFR Part 192.605.

#### OPERATIONS AND MAINTENANCE PLANS

An operations and maintenance plan is required of all natural gas operators by the pipeline safety regulations. The operations and maintenance plan must be written and followed to help the operator comply with the pipeline safety regulations (see 49 CFR §192.603 for further information).

This chapter outlines the procedures that must be addressed in the operations and maintenance plan. For master meter operators, the first 18 of these procedures (lettered A-R) must usually be addressed in the operations and maintenance plan. Four additional procedures (lettered S-V) may apply to some operators of small natural gas systems, but most likely will apply only to larger or more complex systems such as those operated by a small municipality.

Some items addressed in this chapter may not be relevant to every natural gas system. **However, a procedure required by the pipeline safety regulations must be included in the plan.** Some of the key items that pipeline safety inspectors will look for during an audit are:

- completeness of the operations and maintenance procedures;
- omission or deficiency of an applicable portion of the plan;
- not having a plan readily available for review;
- not providing for an annual update and review of the procedures in the plan;
- not having a plan at all.

**OPERATIONS AND MAINTENANCE PLANS MUST CONTAIN THE FOLLOWING COMPONENTS:**

- A. Determination of Class Location(s) - The operator must determine the Class location for each part of its system. More stringent safety requirements may apply in some locations (see 49 CFR §192.5 for further information).
- B. Public Education - Procedures for educating customers, the general public, local government officials, and excavators about natural gas safety issues must be included in the plan and the operator must retain records of the education program (see 49 CFR §192.16 and §192.616 for further information).
- C. Investigation of Failures - The operator must have procedures for analyzing accidents and failures to determine the cause(s) of the failure and to minimize the probability of a recurrence (see 49 CFR §192.617 for further information).
- D. Maximum Allowable Operating Pressure (MAOP) - This is the maximum pressure at which each segment of a natural gas system may operate. The operator establishes MAOP. If the pipeline is tested to the 100 psig recommended in this guidance manual, the MAOP of the system will be 60 psig (see 49 CFR §192.619 for further information).
- E. Tapping and/or Purging of Pipelines - If tapping and/or purging are performed on the pipeline system, any procedure that is utilized must be in the operations and maintenance plan. Necessary information includes type of equipment, qualified personnel, technique, and the applicable procedures for performing the operation (see 49 CFR §192.627 and §192.629 for further information).
- F. Odorization - (Master Meter Operators).  
The plan must contain a provision for the measurement of the odor of natural gas. A quarterly "sniff test" is sufficient if the natural gas company that supplies the gas provides proof of odorization. The operator should ask tenants, especially heavy smokers and the elderly, to smell the gas at an open valve or gas oven burner at various locations in the system. If they cannot detect an odor, the gas supplier should be notified. Make sure to keep records of these tests, including dates, names, and locations. Sample forms are in Appendix B (Form 11) (see 49 CFR §192.625 for further information).

Odorization - (Other than Master Meter Operators).

Operators who must odorize their own gas must ensure that there is enough odorant in the gas to provide a distinct odor when natural gas is present in air at a concentration of one-fifth of the lower explosive limit. The lower explosive limit for natural gas occurs at approximately 4 percent natural gas in air by volume; therefore, odorant must be detectable at approximately 0.8 percent gas in air by volume.

The odorant and its products of combustion must not be toxic to humans or harmful to components of the natural gas system. The odorant must not be soluble in water more than 2.5 to 100 parts by weight.

All operators must follow these basic rules:

- Ensure that all natural gas in distribution mains and service lines is odorized.
- Specify or determine the type of odorant used in the system.
- Specify in the operations and maintenance plan the manufacturer's recommended amount of odorant per million cubic feet (mmcf) of gas.
- Include any maintenance procedures recommended by the manufacturer of the odorization equipment. Odorization equipment must introduce the odorant without wide variation in the amount of odorant per mmcf of natural gas.
- A periodic sampling procedure must be part of the written operations and maintenance plan. This must include periodic testing of the odorant injection rate and testing at various locations, including the outer extremities of the pipeline system, to verify that the odor is distinctive at all locations in all seasons.
- Maintain records of odorant injection rate and odorant sampling. For sample record, see Appendix B, Form 10.

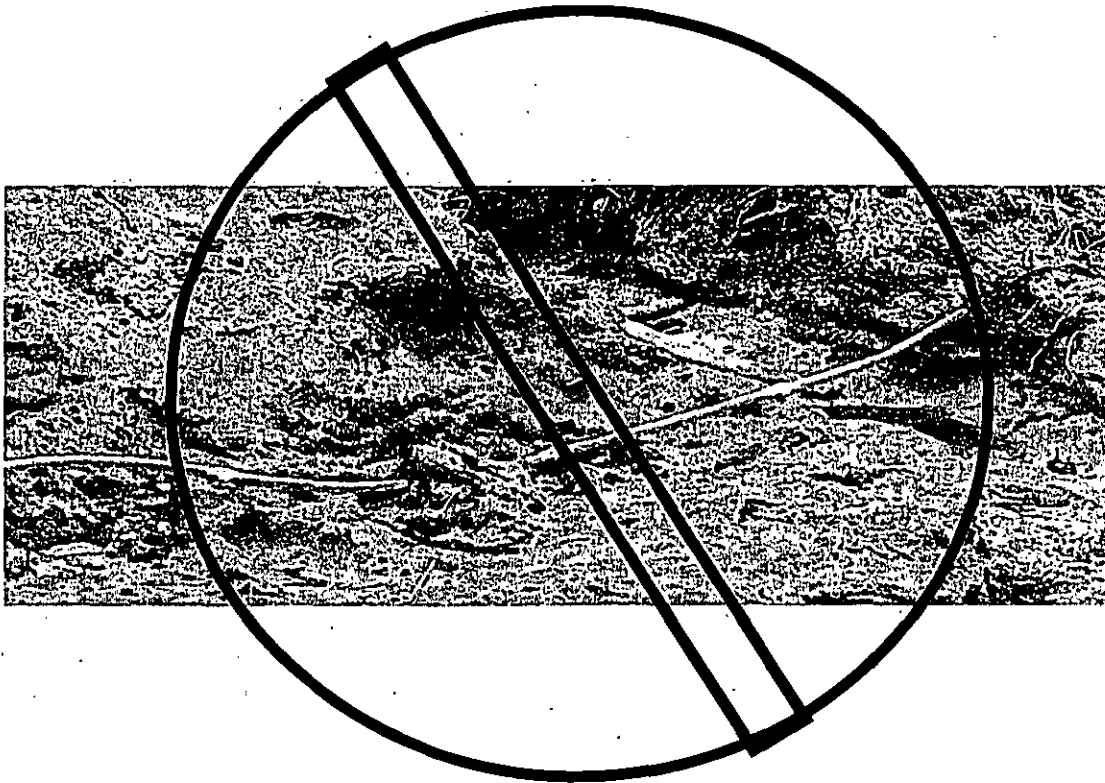
See 49 CFR §192.625 for further information.

G. PATROLLING - Operators must include in the plan provisions for patrolling mains located in places or on structures where anticipated physical movement or external loading (e.g., weight and traffic) could cause failure or leakage. These places include bridges, waterways, landslide areas, areas susceptible to earth subsidence (cave ins), or areas of construction activity.

Patrolling of these mains must be conducted at least four times each year in business districts and twice a year outside business districts (Appendix B, Form 4). Patrolling can be done by walking along the pipeline and observing factors affecting safe operation (see 49 CFR §192.705 for further information).

FIGURE VIII-1

Below is an example of a washout area found by patrol.



- H. Leak Surveys - A survey of a natural gas distribution system with leak detector equipment (FI or CGI) must be made as frequently as necessary, but at least annually.

Most master meter operators use contractors to leak survey their systems. It is the responsibility of the operator to ensure that the survey is conducted in accordance with the pipeline safety regulations. The operator must retain a report describing the results of each survey.

Leak surveys are the most important way in which a gas system operator protects the safety of the community; therefore, these directions need to be carefully followed:

1. A leak survey must be conducted over an entire residential pipeline system at intervals not exceeding five years. Operators should increase the frequency of surveys based on factors such as:
  - (a) Material makeup of system. Certain materials, not all of which are approved for use with natural gas, may develop a higher than average leakage rate (e.g., unprotected bare steel, PVC plastic pipe, extruded tubing, cast iron with lead joints, and coated steel pipe not cathodically protected).

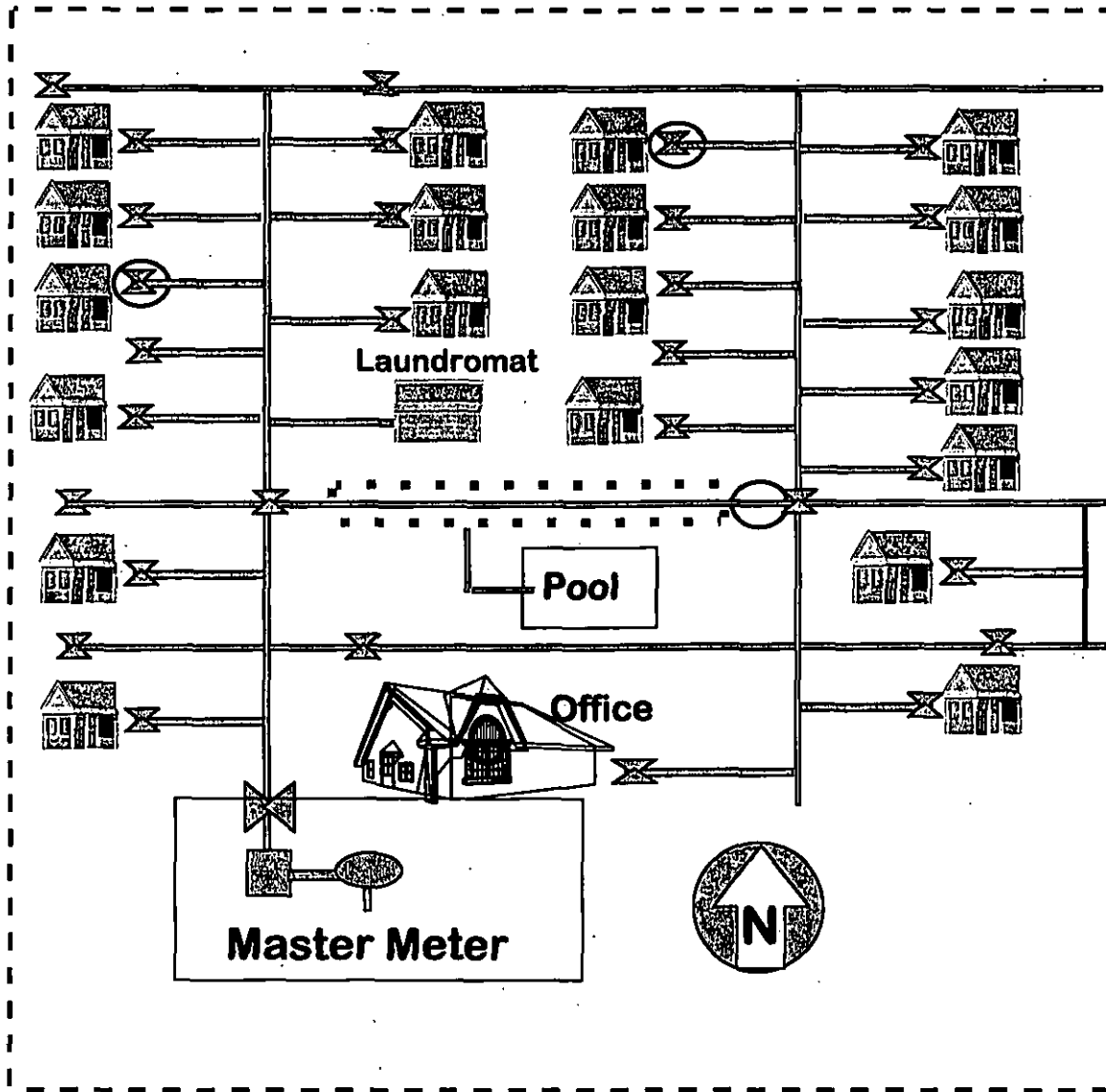
- (b) Age of pipe (over 20 years) and corrosive soil environment.
- (c) Operating pressures.
- (d) Pipe having a previous history of excessive leakage for which the cause has not been determined or eliminated.
- (e) Pipelines in or near buildings, especially schools, churches, hospitals, or other buildings with high occupancy (see APPENDIX B, FORM 3).
- (f) Pipelines located in areas of construction, blasting, or heavy traffic.
- (g) Pipe located in crawl spaces under apartment buildings or mobile homes.
- (h) Service lines and meters inside buildings.




Operators should designate areas that require more frequent surveys.

Available openings should be used to find gas leaks. These include water, sewer, electric, and telephone systems, manholes, cracks in the pavement, and hollow walls (cinder block construction) in areas near natural gas piping. When conducting leak surveys, it is a good policy to check for leaks near the gas pipe entrance, both inside and outside the building. See CHAPTER 4 for details about gas indicator equipment and types of leak surveys.

2. Heavily populated areas require more frequent leak surveys. If the natural gas system is in a business district, a leak survey (utilizing FI or CGI equipment) must be conducted at least once every year (see FIGURE VIII-3). All leaks must be recorded no matter how minor. Sample forms are in Appendix B (Forms 2 and 3).
3. ALL leaks found must be classified as soon as located. All leaks must be investigated to determine if a hazard exists. If a hazardous condition is found, immediate action must be taken. The operator must take action to protect life and property until the hazardous condition is eliminated. Operators may want to include the Gas Piping Technology Committee's (GPTC) "Leak Classification Guide and Action Criteria" in their operations and maintenance plan. See Chapter IV for further information.
4. Although vegetation surveys do not fulfill the requirements of the pipeline safety regulations, they may be used as a supplementary leak detection measure. CHAPTER 4 contains some details about what to look for in vegetation surveys. All leaks must be recorded. Sample forms are in APPENDIX B (FORMS 2 and 3).
5. A map of the distribution system must be marked annually to show leak surveys conducted and the areas tested. Indicate the approximate location of each leak found. Annotations may be made in accordance with FIGURE VIII-2.

Figure VIII-2 Map of a Distribution Leak Survey



-  Flame Ionization Survey
-  Combustible Gas Indicator
-  Leak

- I. Line Markers - The operations and maintenance plan must specify locations for pipeline markers. The following are the federal requirements:

Buried distribution pipelines. A line marker must be placed and maintained as close as possible over each buried distribution main at each crossing of a highway, street, or railroad. A line marker must also be placed wherever necessary to identify the location of the main to reduce the possibility of damage or interference. Line markers are not required for buried mains in Class 3 or 4 locations where it can be shown to be impractical, or where the pipeline system operator participates in a damage prevention program (such as "one-call" or "call before you dig" system).

Distribution pipelines above ground. Line markers must be placed and maintained along each section of a main that is located above ground in an area accessible to the public. A typical example is an unsecured pressure regulating station.

Markers. The following must be written legibly on a background of sharply contrasting color on each line marker:

1. The word "Warning," "Caution," or "Danger" followed by the words "Gas (or name of gas transported) Pipeline." Letters must be at least one inch high with an approximate stroke of one-quarter inch.
2. The name of the operator and the telephone number (including area code) where the operator can be reached at all times (see FIGURE VIII-3).

FIGURE VIII-3

Below is a pipeline marker that meets the federal requirements (see 49 CFR §192.707 for further information).



- J. Testing for Reinstating a Service Line - The plan must contain a provision for testing each disconnected service line from a main before placing it back into service. For small distribution and master meter operators testing at 100 psig is suggested. See 49 CFR §192.511 for further information.
- K. Abandonment of Facilities - The plan must include provisions for shutdown, abandonment, or inactivation of facilities. When a gas main or service line is abandoned, it must be physically disconnected at both ends and the open ends must be sealed. In addition, the operator must determine if it is necessary to purge the line. This determination should take into consideration the location and size of the main or service. Pipe four inches and larger should always be purged. However, the pipeline need not be purged when the volume of gas is so small that there is no potential hazard (see 49 CFR §192.727 for further information).

Records must be kept on all abandoned facilities. This includes location, date, and method of discontinuing service.

When service to a customer is discontinued, one of the following must be done:

1. The valve must be closed to prevent the flow of natural gas to the customer. This valve must be secured with a lock or some other device to prevent opening of the valve by unauthorized persons. There are numerous locking devices designed for this purpose (see FIGURES VIII-4 and VIII-5).
2. A mechanical device or fitting that will prevent the flow of gas must be installed in the service line or in the meter assembly.
3. The customer's piping must be physically disconnected from the gas supply and sealed at both ends (see FIGURE VIII-6).

FIGURE VIII-4

Below is an example of a service line valve which has been locked to prevent the opening of the valve by unauthorized people.

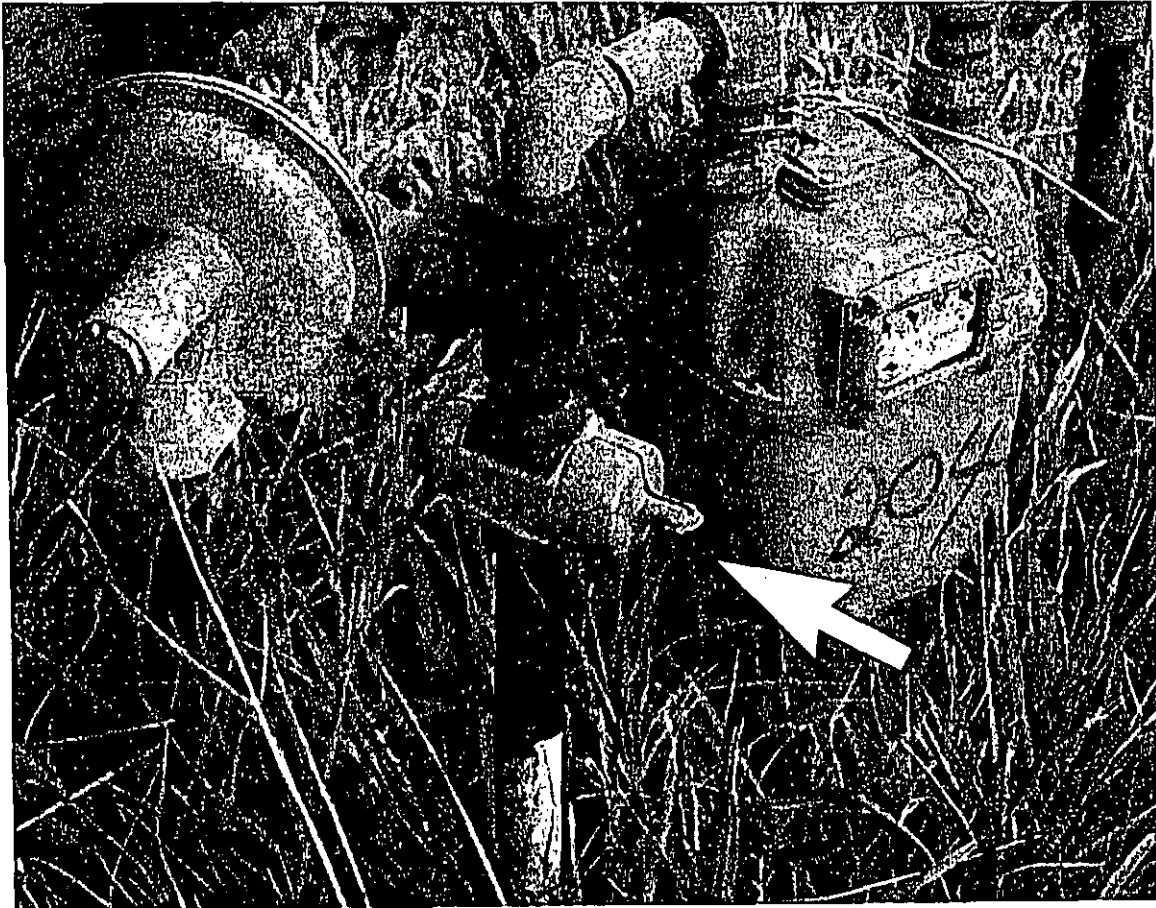


FIGURE VIII-5

Below is an example of a service that has been shut off (note position of meter valve) but not locked to prevent opening. This DOES NOT meet the pipeline safety regulations.

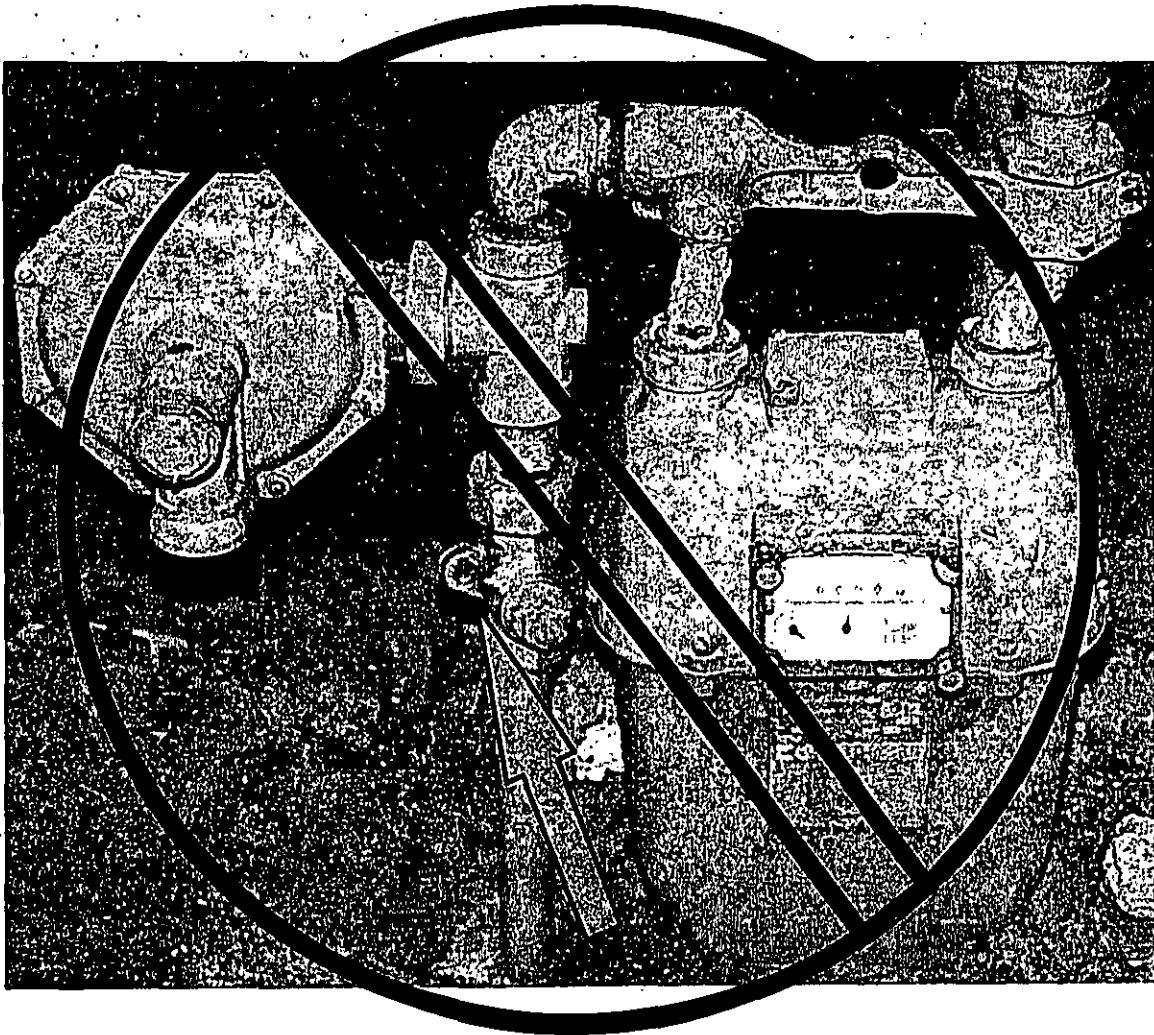
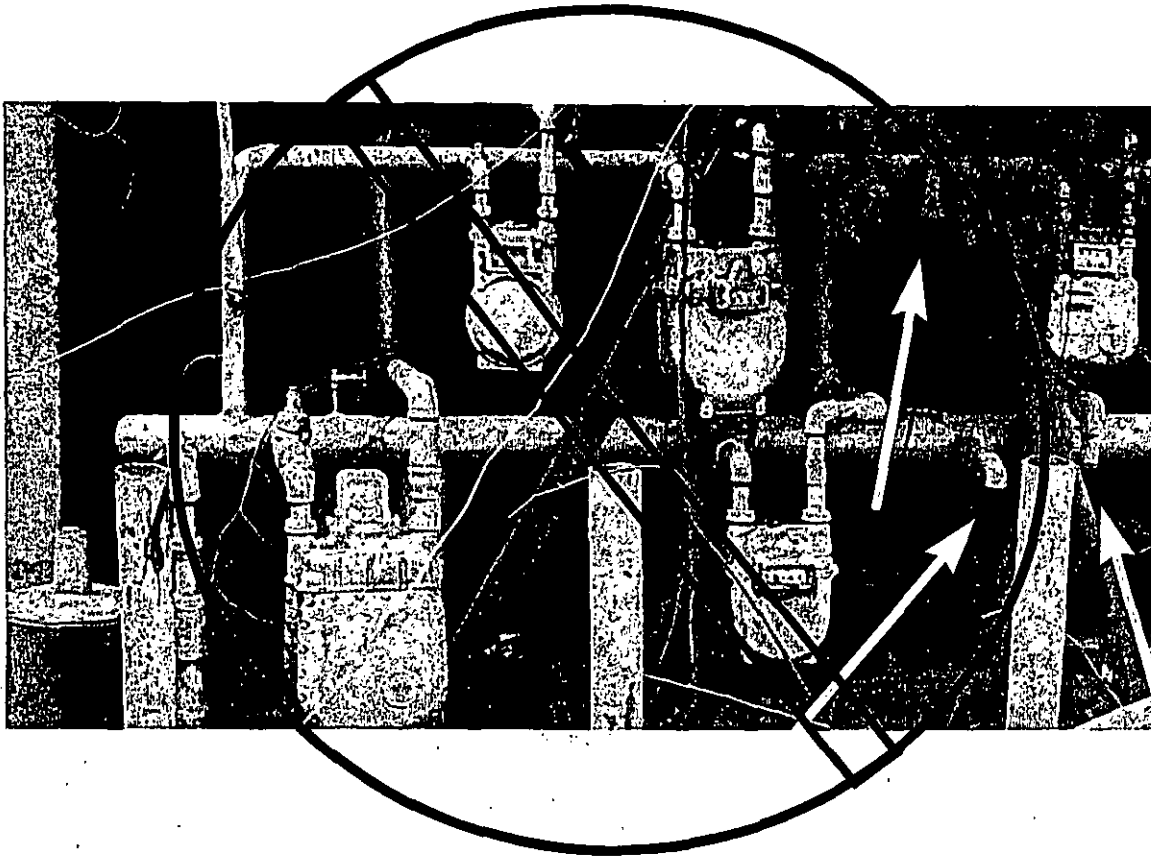


FIGURE VIII-6

Below is an example of service meters that were removed but the shutoff valve of each was not locked, and the pipes were not plugged. This is A VIOLATION of the pipeline safety regulations.



- L. Key Valve Maintenance - Key valves, or critical valves, are the valves needed to shut down the system, or part of the system, in case of an emergency. For most master meter systems, this may involve only one or two valves. Key valves must be checked at least once every year to ensure that they are operable. Procedures for key valve inspections and maintenance of records must be included in the plan. Sample forms are in APPENDIX B (FORMS 8 and 9). See 49 CFR §192.747 for further information.
- M. Accidental Ignition of Gas - The plan must include provisions to prevent the accidental ignition of gas. Gas alone is not explosive, but when mixed with air in a 4 to 15 percent concentration it can ignite or explode. Every precaution should be taken to prevent unintentional ignition of natural gas. When venting a hazardous amount of natural gas, a fire extinguisher must be available and ready for immediate use. See 49 CFR §192.751 for further information.

N. Corrosion Protection - Provisions should be made in the operations and maintenance plan for corrosion protection if the system contains metal pipe. The plan should include procedures for the following:

- Implementing a corrosion control program. This must be under the direction of a person qualified by experience and training in pipeline corrosion control methods.
- Ensuring coating and cathodic protection of new steel pipe (APPENDIX B, FORM 14).
- Ensuring cathodic protection of existing pipe (APPENDIX B, FORM 14).
- Examining pipe when exposed (APPENDIX B, FORM 1).
- Testing the effectiveness of cathodic protection every year (APPENDIX B, FORM 14).
- Inspecting rectifiers, if used in an impressed current cathodic protection system, at least 6 times a year. (APPENDIX B, FORM 15).
- Checking for atmospheric corrosion (APPENDIX B, FORM 13).
- Maintaining records of all tests, surveys, and inspections.

*These requirements are discussed in more detail in CHAPTER III. Corrosion theory, practical concepts, and illustrations are contained in CHAPTER III. See 49 CFR §§192.451-192.491 for further information.*

O. Construction and Leak Repair - The operations and maintenance plan should contain procedures for construction and leak repair. CHAPTER VI of this manual gives some basic procedures and concepts.

P. Construction Records, Maps and Operating History - The operator must have and follow procedures in the plan to make construction records, maps and operating history of the natural gas system readily available to operating personnel.

Q. Gathering of Data Needed for Reporting Incidents - The plan must include procedures to compile information on pipeline incidents and safety-related conditions. These procedures need to ensure accurate and timely reporting. This information must be readily available. See 49 CFR Part 191 for further information.

R. Starting Up and Shutting Down any Part of the Pipeline - The plan must include step-by-step actions for start-up and shut-down of the pipeline system. This will ensure that the MAOP is not exceeded on any portion of the pipeline system. See 49 CFR §192.605 for further information.

**NOTE:** THE FOLLOWING SECTIONS WILL NOT USUALLY APPLY TO MASTER METER OPERATORS.

- S. Upgrading - The operations and maintenance plan must contain upgrading procedures only if upgrading is contemplated. If a system requires upgrading, contact the state regulatory agency or the OPS regional office for detailed instructions. See 49 CFR §§192.551-192.557 for further information.
- T. Inspection of Regulating Stations - If regulating stations are a part of the system, the plan must include provisions for their inspection and testing. Many master meter systems will not have a regulating station. This section does not apply if an operator does not lower the gas pressure from the local gas utility delivery pressure except at a customer service regulator.

For operators with regulating stations, provisions must be made in the operations and maintenance plan to inspect and test both regulators and relief devices. These must be inspected every year to determine that they are:

- in good mechanical condition;
- adequate in capacity and reliability of operation;
- set to function at the correct pressure;
- properly installed and protected from vehicular traffic, dirt, liquids, icing, and other conditions that might prevent proper operation.

A record of this annual inspection must be kept. Sample forms are in APPENDIX B (FORM 6). The operator must inspect visually, perform an operation check (stroke and lock up), and check the set pressure of the relief device and regulator. Problems may include:

- low distribution system pressure;
- unsatisfactory operating and maintenance history;
- dirty or wet gas supply;
- inoperative safety devices.

The operator may need technical help to solve these problems, especially if regulator disassembly or station redesign is necessary. THE OPERATOR IS CAUTIONED NOT TO DISASSEMBLE REGULATORS WITHOUT THOROUGH TRAINING BY THE REGULATOR MANUFACTURER OR AN INDEPENDENT CONSULTANT.

The operator should always keep and use the manufacturers' manuals, diagrams, and maintenance procedures for each type of regulator used in the system.

CHAPTER II contains some basic concepts about pressure regulation and relief devices. See 49 CFR §192.739 and §192.743 for further information.

U. Testing of Relief Devices at Regulating Stations - At a minimum, the operations and maintenance must include procedures for the inspection of relief devices. Relief devices should be inspected as follows:

- Existing pressure limiting and regulating stations must be inspected and tested for operating condition at least once a year.
- If the relief device has insufficient capacity, the operator must replace it.
- The stations must be protected from damage from outside forces (cars, trucks, falling objects, etc.).

Usually, the gas pipeline company or the local distribution company owns and maintains the relief devices at regulation stations. However, if an operator owns relief devices at regulation stations, provisions must be made in the plan for capacity testing. If not feasible, the calculations of capacity must be reviewed each year. The operator must maintain a copy of this calculation. The test must show that the relief valve capacity is adequate for the system's MAOP.

The regulations recognize two types of distribution systems: low pressure and other-than-low pressure. The relief capacity for low pressure must protect the customer's gas utilization equipment from overpressure. The gas pressure in the main is approximately the same as the pressure provided the customer - usually 4 to 8 inches water column for natural gas.

In an other than low pressure distribution system, the relief device must be set to operate such that if the MAOP is 60 psig or more, the pressure during an emergency may not exceed the MAOP plus 10 percent. If testing reveals that the relief devices do not have adequate capacity, then new or additional devices must be installed.

Capacity must be checked for each separately controlled section of the natural gas system. The operator must ensure that the MAOP will not be exceeded at any point downstream of the regulator station if the worst condition occurred - that is, if the regulator fails when fully opened. Most small systems have only one MAOP for all piping in the distribution system.

In summary, the combination of minimum customer usage and relief capacity must ensure the MAOP will not be exceeded (except to the extent described above).

To comply with this requirement, many operators of small systems have a consultant analyze their gas system and make the required relief valve capacity calculations. If the

analysis proves that the relief valve has adequate capacity, the operator must keep a copy of this calculation on file. If there have been no changes to upstream regulators, such as different pressure, orifice, or type of regulator, the calculation of capacity need only be reviewed (and initialed) on an annual basis. If a change is made, the new relief valve capacity calculations must be made and kept on file. It is a good idea to keep this capacity calculation with the annual inspection record. Sample forms are in APPENDIX B (FORM 7). For other considerations for relief and regulating stations (see CHAPTER II).

V. Cast Iron Pipe - Operations and maintenance plans must address the unique safety issues of cast iron pipe. Each cast iron caulked bell-and-spigot joint that is subject to pressures of 25 psig or more must be sealed with either a mechanical leak clamp or device which:

- Does not reduce flexibility of the joint;
- Permanently bonds (either chemically, mechanically, or both) with the bell and spigot, metal surfaces, or adjacent pipe metal surfaces;
- Seals and bonds in a manner that meets the strength, environmental, and chemical compatibility requirements of 49 CFR §192.53(a)(b) and §192.143.

Each cast iron caulked bell or spigot joint that is subject to a pressure of less than 25 psig, must be sealed by a means other than caulking if it is exposed for any reason.

If an operator has knowledge that the support for a segment of a buried cast iron pipeline has been disturbed, that segment of the pipeline must be protected as necessary. Examples of disturbances are:

- Vibrations from heavy construction equipment, trains, trucks, buses, or blasting;
- Impact forces by vehicles;
- Earth movement;
- Excavations near the pipeline;
- Other known or foreseeable outside forces that may have or could subject that segment of the pipeline to bending stresses.

Operators of cast iron pipe located in earthquake-prone areas should consider replacing the pipe as soon as practical. Experience has shown that cast iron is prone to failure from severe earth movement. See 49 CFR §192.753 and §192.755 for further information.

#### EMERGENCY PLANS

General information on developing an emergency plan. See 49 CFR §192.615 for further information.

Each operator is required to keep a written plan of procedures to cope with gas emergencies. The emergency plan should contain the following information:

1. Emergency notification list.
2. Map of key valve locations.
3. Description and location of emergency equipment.
4. How to respond to gas leak reports and interruptions of gas service.
5. Check list for use in emergency situations.
6. Reporting requirements (Telephone Reports).
7. How to restore gas service after an outage.
8. Accident investigation procedures.
9. Education and training plan.

A. Emergency Notification List - The telephone numbers of the operator, fire department, gas company and any other entity whose service may be necessary in an emergency must be readily accessible. For master meter operators, a copy of this list should be posted in a public area. It is recommended that the direct lines to emergency services such as the fire department are included in addition to the general emergency number (i.e., 911). These numbers must be kept up-to-date.

B. Map of Key Valve Locations - A map of the gas pipeline showing the location of master meters and key valves must be included in the emergency plan.

C. Description and Location of Emergency Equipment- Emergency equipment must be available. A description of this equipment and its location must be specified in the plan.

D. Responding to Gas Leak Reports and Interruption of Gas Service - The operator must have written procedures to be followed in response to gas leaks reported by customers. It is the responsibility of the operator of the natural gas distribution system to ensure that all employees are familiar with procedures for responding to gas leak calls and reports.

1. The employee receiving a report of a gas leak must get as much of the information as possible to fill out the leak report (APPENDIX B, FORM 2). Use common sense: saving human life is the first priority, then property.
2. All reports of leaks on customer premises get priority. LEAKS INSIDE A BUILDING GET TOP PRIORITY.
3. After determining that a hazardous leak exists inside a building, remind the customer of the following:

- Do not turn on or off any electrical switches.
  - Do not ring door bells or use telephones.
  - Do not light matches, cigarettes, etc.
  - Do not start automobiles or other engines.
  - Do extinguish all open flames.
  - Do evacuate building to a safe distance (about a block).
  - Do turn off gas supply, if feasible.
4. Dispatch necessary personnel to the location of the reported leak, including local emergency responders, such as the fire department and police.
5. Duties of First Company Employee on the Scene:

TAKE EVERY CORRECTIVE ACTION NECESSARY TO PROTECT LIFE AND PROPERTY FROM DANGER (IN THAT ORDER.) IT IS THE RESPONSIBILITY OF THE PERSON IN CHARGE TO:

- Set up communications.
  - Coordinate the on-scene emergency response operation.
  - Make decisions concerning emergency valves, isolating areas, and use of emergency equipment.
  - Implement the checklist for emergency situations.
6. Minimum Operator Response Actions for Leaks Near Buildings:
- Assess danger to building occupants, to the public and to property.
  - Extinguish all open flames.
  - If necessary, notify fire, police, and gas company.
  - Block street and stop traffic.
  - Notify supervisor or other responsible persons.
  - Leak survey next to foundation of building including the use bar holes.
  - Check neighboring buildings for gas.
  - Implement checklist for emergency situations.
  - Repair leak.
  - Return occupants to buildings only when positively sure it is safe.
7. Minimum Operator Response Actions for Leaks Inside a Building:
- Evaluate immediately to determine concentration of gas and source of leak.
  - Evacuate if necessary.
  - Do not operate electrical switches.

- Do not use telephone.
- Shut off gas meter valve.
- Perform a bar hole leak test of the area especially around foundation. Check water meter and other openings.
- If ground and house are gas free, turn on meter valve. Check all gas piping and appliances for leaks. (Is meter hand turning normally or spinning?)
- Conduct soap bubble test.
- Implement checklist for emergency situations.
- Repair leak.
- If leak cannot be repaired, notify customer. Turn off meter, lock it and tag it.

8. Gas Burning Inside a Building:

- Call fire department.
- Master meter operators should also call local natural gas utility.
- If fire is at an appliance, shut gas off at appliance valve.
- If not possible to shut gas off at appliance valve, shut gas off at meter or stop valve.
- Implement checklist for emergency situations.

E. Checklist for a Major Emergency

- \_\_\_\_\_ 1. Has fire department been called?
- \_\_\_\_\_ 2. Have persons been evacuated and area blockaded?
- \_\_\_\_\_ 3. Has police department been notified?
- \_\_\_\_\_ 4. Has repair crew been notified?
- \_\_\_\_\_ 5. Has company call list been executed?
- \_\_\_\_\_ 6. Has communication been established?
- \_\_\_\_\_ 7. Has outside help been requested?
- \_\_\_\_\_ 8. Have ambulances been called?
- \_\_\_\_\_ 9. Has leak been shut off or brought under control?
- \_\_\_\_\_ 10. Has civil defense been notified?
- \_\_\_\_\_ 11. Have emergency valves or proper valves to shut down or reroute gas been identified and located?
- \_\_\_\_\_ 12. If an area has been cut off from a supply of gas, has the individual service of each customer been cut off?
- \_\_\_\_\_ 13. Is the situation under control and has the possibility of recurrence been eliminated?
- \_\_\_\_\_ 14. Has surrounding area, including buildings adjacent to and across streets, been probed for the possibility of further leakage?
- \_\_\_\_\_ 15. Has proper tag been put on meter?
- \_\_\_\_\_ 16. Has telephonic report to the state been made?
- \_\_\_\_\_ 17. Has telephone report to OPS been made?
- \_\_\_\_\_ 18. Has radio station been given instructions (if necessary)?

Date: \_\_\_\_\_

F. Reporting Requirements (Telephonic Report) - In case of an incident, a telephone report must be made immediately to the National Response Center (1-800-424-8802) or in Washington, D.C. (267-2675). An incident is an event involving release of gas from a pipeline and:

1. Death or injury requiring in-patient hospitalization; or
2. Estimated property damage of \$50,000 or more.

G. Restoration of Gas Service After an Outage - Qualified persons must follow proper procedures to safely restore gas service after an outage. These procedures must include details of appliance relighting procedures.

Gas service must be restored on a building-to-building basis throughout the affected area. First, service to each customer must be turned off, either at the meter or at street service valves. If street service valves cannot be located, the gas flow can be shut off by squeeze-off, stoppering, etc.

In restoring service to an affected area all gas piping and meters must be purged and appliances relighted. Never turn on gas at the meter unless access is available to ALL appliances on the customer piping. In the event that a customer is not present, notification must be left in a noticeable location requesting the customer to call the natural gas company to arrange for restoration of service. (See Figure VIII-7 for an example of cards.)

The person in charge is to coordinate this operation and be responsible for it. A complete record of the incident, with drawings, etc., must be kept on file.

FIGURE VIII-7

The image shows a safety card with a left side for recording incident details and a right side with a 'DANGER' warning. The left side is divided into four sections, each with a line for a date and a line for worker's initials. The right side contains a 'DANGER' warning in large letters, followed by instructions: 'DO NOT TAMPER WITH OR TURN ON THIS METER', 'THIS METER IS SHUT OFF DUE TO A BIG', and 'EMERGENCY' in large letters.

TURNED OFF DATE	<b>DANGER</b> DO NOT TAMPER WITH OR TURN ON THIS METER THIS METER IS SHUT OFF DUE TO A BIG <b>EMERGENCY</b>
UNABLE TO TURN OFF DATE	
WORKER'S INITIALS	
TURNED ON DATE	
DID NOT TURN ON BECAUSE UNABLE TO ENTER TO RELIGHT APPLIANCES DATE	

## H. Investigation Procedures

Each operator must establish procedures for investigating incidents and failures including:

- Evaluating the situation.
- Protecting life and property.
- Securing the area.
- Conducting a leak survey.
- Conducting pressure tests of piping.
- Conducting meter and regulator checks.
- Questioning persons on the scene.
- Examining burn and debris patterns.
- Testing odorization level.
- Recording meter reading.
- Recording weather conditions.
- Selecting samples of the failed facility or equipment for laboratory examination for the purpose of determining the causes of the failure and minimizing the possibility of recurrence.

## I. Education and Training - Operating personnel must be qualified to ensure understanding of and competency in emergency procedures.

### Employee Training

Employees must be qualified in emergency procedures, including:

1. Updates of Emergency Plan.
2. Review of responsibilities in an emergency.
3. Review of locations and use of emergency equipment.
4. Properties of natural gas.
5. Review the locations and use of:
  - System maps.
  - Main records.
  - Service records.
  - Valve records.
  - Regulator station schematics.

6. Review of hypothetical emergency situations to reinforce the step-by-step actions to be taken in emergency situations, including how to contact public officials, firefighters, police, gas company, etc.
7. Recordkeeping requirements.
8. Telephone reports (OPS, state agency, etc.)

#### Public Education

Each operator must have a continuing education program that enables customers, the public, emergency response groups, and persons engaged in excavation activities, to recognize and respond to an emergency situation:

Program material should include:

- Information about gas properties.
- Recognition of gas odors.
- Actions to take when a strong gas odor is present.
- Notification of the gas company prior to excavation.
- Telephone numbers for customers to report gas leaks during both business and non-business hours.

There are many excellent pamphlets published by state and regional gas associations and by the American Gas Association and the American Public Gas Association on the properties of gas and emergency information. This information can be obtained from these organizations at no cost or for a small nominal charge. See the enclosed handout for addresses and telephone numbers of these organizations.

This information may be conveyed to the public by a number of means:

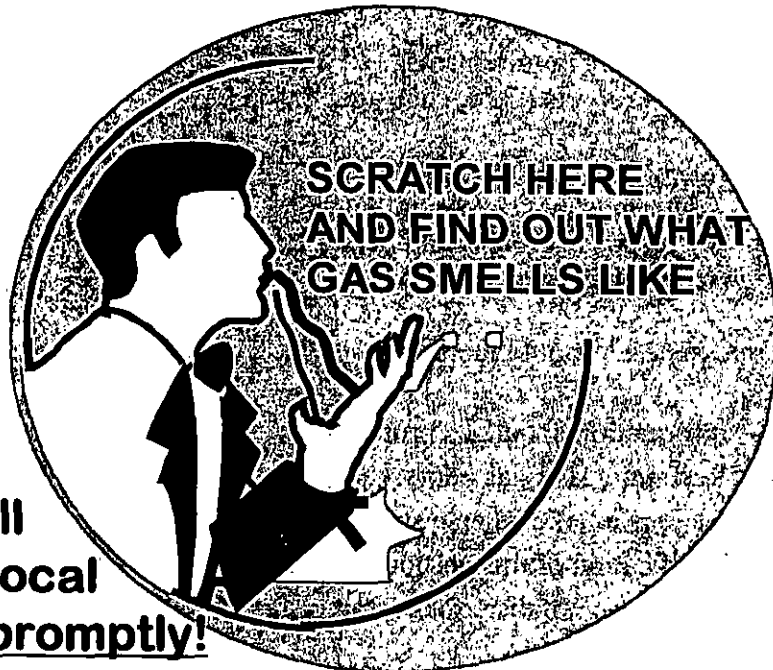
- Radio and television.
- Newspapers.
- Newsletters.
- Meetings.
- Bill stuffers.
- Mailings.
- Hand outs.
- Bulletin board.

If residents do not speak English, the operator must pass the same information in a language they can understand. For examples of information that can be sent to the public, see FIGURES VIII-8, VIII-9, and VIII-10.

The operator must maintain a record of the public education program. See 49 CFR §192.615 for further information.

FIGURE VIII-8

# Identify the smell!



**If you ever smell  
gas, call your Local  
Gas Company promptly!**

Natural gas is odorless in its natural state. We add this disagreeable smell to let you know if any gas is escaping.

Gas leakage may occur from faulty appliances, loose connections, service lines inside or outside your home, or from gas mains. Leaks can be dangerous and should be dealt with promptly by experts.

**IF YOU EVER SMELL GAS -- even if you do not use it in  
in your home -- take these precautions promptly:**

1. Call your local Gas Company.
2. If odor is very strong and you are indoors, go outside.
3. Do not turn any electrical switches on or off.
4. Do not light matches, smoke or create any other source of combustion.

However slim the chances of danger, it doesn't pay to needlessly risk. At the first sniff of gas, play it safe. Call us!

## HOW CAN YOU PREVENT GAS EMERGENCIES

- ① Keep all appliances cleaned, properly vented and serviced regularly.
- ② Make sure everyone in your family knows how to operate gas appliances and shut-off valves.
- ③ Don't use an open gas oven for heating your home or drying clothes.
- ④ Don't use or store gasoline, aerosols or other products with flammable vapors near gas appliances.
- ⑤ Whenever changing your furnace filter be sure to replace the compartment door.
- ⑥ Never cover fresh air vents that supply air to your gas appliances.
- ⑦ Have all gas line alterations and appliance repairs performed by a professional.
- ⑧ Before digging in your yard, be sure you know the location of underground gas lines. Call your local One Call Center.
- ⑨ Write your fire and police department phone numbers and our emergency service number in the front of your phone book.

ANYTIME YOU SUSPECT A GAS LEAK OR GAS EMERGENCY CALL YOUR LOCAL GAS COMPANY. THEY'RE EXPERTS AT THEIR JOB, AND RESPOND TO EMERGENCY CALLS.

## WHAT IS NATURAL GAS?

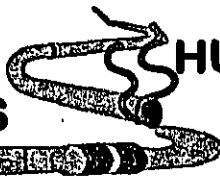
Natural gas is a non-toxic, colorless fuel, about one-third lighter than air. Gas burns, but only when mixed with air in the right proportion and ignited by a spark or flame. In its purified state, gas has no smell. For your protection, the Gas Company adds a harmless, distinctive odor so you can detect and report the slightest gas leak.

## HOW SAFE IS NATURAL GAS?

Natural gas has an excellent safety record, but like other forms of energy, it requires a certain amount of caution. Gas emergencies are rare, but they can happen:

- \* Whenever gas leaks from a pipe or pipe fitting, there is a possibility of fire or explosion.
- \* If leaking gas accumulates in a confined space, it can displace air and cause suffocation.
- \* If a gas appliance is not working properly, incomplete combustion can produce carbon monoxide and other toxic gases.
- \* A pilot light or gas burner can ignite combustible materials and flammable vapors, such as gasoline, paint thinner or aerosols.

**KNOW  
WHAT  
GAS  
SMELLS  
LIKE!**



**¡SEPA A  
QUE  
HUELE  
EL  
GAS!**

**If you ever smell gas, call  
your Local Gas Company  
promptly.**

**Si huele a gas alguna vez, llame  
inmediatamente a la Compañía  
Local de Gas al.**



**Local Gas**

## REPORTS REQUIRED BY THE FEDERAL GOVERNMENT

The federal government requires every gas operator to telephone a report of any "incident," and **except, for master-meter operators**, report by fax or mail of a "safety-related condition" and to file an annual report. This chapter briefly describes each of these reports. REMEMBER to check with your state agency for any additional state reporting requirements.

### INCIDENT REPORT

It is required to telephone an incident report at the earliest possible moment, but in any case, within two hours of a release of natural gas from a pipeline which results in:

- a death or personal injury requiring hospitalization or estimated property damage, including the cost of gas lost, of \$50,000 or more;
- an event that is significant in the judgment of the operator, even though it was not described above.

This telephone report of a serious incident should include:

- identity of reporting operator;
- name and phone number of individual reporting the incident;
- location of the incident (city, county, state, and street address);
- time of the incident (date and hour);
- number of fatalities and personal injuries, if any;
- type and extent of property damage;
- description of the incident.

The telephone incident report can be made at anytime to the National Response Center at:

TOLL FREE (800) 424-8802  
IN WASHINGTON, D.C.  
(202) 267-2675

### **REMEMBER, WHEN IN DOUBT, MAKE THE CALL!**

See 49 CFR §191.5 for further information.

An incident requiring a telephone report must be followed by a written report unless a master meter system operator makes the report.

### Address for Incident Reports

All required reports must be submitted to:

Information Resources Manager  
Office of Pipeline Safety  
Research and Special Programs Administration  
Nassif Building, Room 2335  
400 Seventh Street, SW  
Washington, DC 20590

See 49 CFR §191.9 for further information.

### **SAFETY-RELATED AND CONDITION REPORTS**

**NOTE:** This rule does not apply to master meter operators.

OPS requires operators of natural gas pipelines to report certain safety-related conditions.

A written report must be filed within 5 working days after the operator first determines that a "safety-related condition" exists, but not later than 10 working days after the day the operator discovers the condition.

Each operator is also required to update its operations and maintenance plan to enable personnel who perform operation and maintenance activities to recognize conditions that may be safety-related conditions.

Typical conditions that need to be reported by operators of small natural gas systems include:

- unintended movement or abnormal loading of pipeline facilities by environmental causes such as earthquakes, landslides, or floods, that impairs the serviceability of a pipeline;
- any malfunction or operating error that causes the pressure of a pipeline to rise above its maximum allowable operating pressure plus the pressure build-up allowed for operation of pressure limiting or control devices;
- a leak that constitutes an emergency and is not repaired within 5 days of determination;
- a safety-related condition that could lead to imminent hazards and cause the operator to make a 20 percent or more reduction in operating pressure.

The above is only a summary. Refer to 49 CFR §191.23(a) for a complete listing of all safety-related conditions that must be reported.

Safety-related conditions that do not require a report include:

- condition on a customer-owned service line;
- a condition resulting in an incident, as defined in 49 CFR §191.3;

- a condition on a pipeline more than 220 yards from any building or outdoor place of assembly, unless it is within the right-of-way of an active railroad, paved road, or highway;
- a condition that is corrected before the report filing deadline, except for certain corrosion related conditions.

See 49 CFR §191.23(b) for further information.

Address for Safety-Related Condition Reports

All required written reports must be submitted to:

Information Resources Manager  
Office of Pipeline Safety  
Research and Special Programs Administration  
Nassif Building, Room 2335  
400 Seventh Street, SW  
Washington, DC 20590  
Fax: (202) 366-4566

In addition, an intrastate operator may be required to file a report with the state agency participating in the pipeline safety program. For further details on the filing requirements, refer to 49 CFR §191.7.

ANNUAL REPORTS

With the exception of master meter operators, each operator of a distribution pipeline system must submit an annual report for that system. This report must be submitted on DOT Form RSPA F7100.1-1. This report must be submitted each year, not later than March 15, for the preceding calendar year.

Address for Annual Reports

All required reports must be submitted to:

Information Resources Manager  
Office of Pipeline Safety  
Research and Special Programs Administration  
Nassif Building, Room 2335  
400 Seventh Street, SW  
Washington, DC 20590

See 49 CFR §191.11 for further information.

# **APPENDIX A**

**GLOSSARY**

**AND**

**ACRONYMS**

## GLOSSARY

To understand this manual, operators of small natural gas systems need to know the meaning of some commonly used terms. The terms are defined below for the purpose of this guidance manual. The reader is referred to 49 CFR Parts 191 and 192 for additional definitions.

**ANNUALLY** – means at intervals not exceeding 15 months, but at least once each calendar year.

**CATHODIC (CORROSION) PROTECTION** – a procedure by which underground metallic pipe is protected against deterioration (rusting and pitting). Basic theory, concepts, and practical considerations for cathodic protection are contained in Chapter III.

**CUSTOMER METER** – a device that measures the volume of gas transferred from an operator to the consumer.

**DOWNSTREAM** – any point in the direction of flow of a gas from the reference point.

**EMERGENCY PLAN** – written procedures for responding to emergencies on the pipeline system.

**GAS OPERATOR** – a gas operator may be a gas utility company, a municipality, or an individual operating a housing project, apartment complex, condominium, or a mobile home park served by a master meter. The operator is ultimately responsible for complying with the pipeline safety regulations.

**HIGH-PRESSURE DISTRIBUTION SYSTEM** – a distribution system in which the gas pressure in the main is higher than the pressure provided to the customer; therefore, a pressure regulator is required on each service to control pressure to the customer.

**INCIDENT** – an event that involves a release of natural gas from a pipeline facility that results in: (1) a death or personal injury necessitating in-patient hospitalization; (2) estimated property damage of \$50,000 or more; or (3) an event that the operator deems significant (check with your local state authorities for additional requirements, APPENDIX C).

**LOW-PRESSURE DISTRIBUTION SYSTEM** – a distribution system in which the gas pressure in the main is substantially the same as the pressure provided to the customer; normally a pressure regulator is not required on individual service lines.

**MAIN** – a natural gas distribution pipeline that serves as a common source of supply for more than one service line.

**MASTER METER SYSTEM** – a natural gas pipeline system for distributing natural gas for resale within, but not limited to, a distinct area, such as a mobile home park, housing project, or apartment complex, where the operator purchases metered gas from an outside source. The natural gas distribution pipeline system supplies the ultimate consumer who either purchases the gas directly through a meter or by other means such as by rent.

**MAXIMUM ALLOWABLE OPERATING PRESSURE (MAOP)** – the maximum pressure at which a pipeline may be operated in compliance with the gas pipeline safety regulations. It is established by design, past operating history, pressure testing, and pressure ratings of components.

**MUNICIPALITY** – a city, county, or any other political subdivision of a state.

**NATURAL GAS** – a non-toxic, colorless fuel, about one-third lighter than air. Natural gas burns only when mixed with air in certain proportions and ignited by a source of ignition (spark or flame) (Figure IV-4). Natural gas in its natural state may not have an odor.

**OPERATING AND MAINTENANCE PLAN** – written procedures for operations and maintenance on natural gas pipeline systems.

**OVERPRESSURE PROTECTION EQUIPMENT** – equipment installed to protect and prevent pressure in a system from exceeding the maximum allowable operating pressure (MAOP).

**PIPELINE** – all facilities through which gas moves in transportation. This includes pipes, valves, and other items attached to the pipe, meter stations, regulator stations, delivery stations, holders, and fabricated assemblies.

**PRESSURE REGULATING/RELIEF STATION** – a device to automatically reduce and control the gas pressure in a pipeline downstream from a higher pressure source of natural gas. It includes any enclosures, relief devices, ventilating equipment, and any piping and auxiliary equipment, such as valves, regulators, control instruments, or control lines.

**PRETESTED PIPE** – pipe that has been tested by the operator to 100 psig for at least one hour.

**SERVICE LINE** – a natural gas distribution line that transports gas from a common source of supply to a customer's meter, or to the connection to a customer's piping if the piping is farther downstream or if there is no meter.

**SERVICE REGULATOR** – a device designed to reduce and limit the gas pressure provided to a customer.

**SERVICE RISER** – the section of a service line which extends out of the ground and is often near the wall of a building. This usually includes a shut-off valve and a service regulator.

**SHUT-OFF VALVE** – a valve used to stop the flow of gas. The valve may be located upstream of the service regulator or below ground at the property line or where the service line connects to the main.

**UPSTREAM** – from a reference point, any point located nearest the origin of flow, that is, before the reference point is reached.

**49 CFR** – Title 49 of the Code of Federal Regulations (CFR). This document contains the actual safety regulations that must be complied with by the natural gas operator. Parts 190, 191, 192, and 199 of 49-CFR contain the federal pipeline safety regulations relevant to operators of natural gas pipeline systems.

## **COMMONLY ABBREVIATED ORGANIZATION/ACRONYMS**

**AGA** – American Gas Association.

**ANSI** – American National Standards Institute, formerly the United States of America Standards Institute (USASI). All current standards issued by USASI and American Standard Association (ASA) have been redesignated as American National Standards Institute and continue in effect.

**APGA** – American Public Gas Association.

**API** – American Petroleum Institute.

**ASME** – American Society of Mechanical Engineers.

**ASTM** – American Society for Testing and Materials.

**DOT** – U.S. Department of Transportation.

**GPTC** – Gas Piping Technology Committee.

**INGAA** – Interstate Natural Gas Association of America.

**MEA** – Midwest Energy Association.

**MSS** – Manufacturers Standardization Society of the Valve and Fittings Industry.

**NACE** – National Association of Corrosion Engineers. (NACE International)

**NFPA** – National Fire Protection Association.

**OPS** – Office of Pipeline Safety. The pipeline safety division of the DOT's Research and Special Programs Administration. For addresses of OPS regional offices, see the attached list of agencies and organizations.

**RSPA** – Research and Special Programs Administration. A major subdivision of the DOT, it includes the Office of Pipeline Safety. For addresses of regional offices, see the enclosed handout.

**SGA** – Southern Gas Association.

# APPENDIX B

## SAMPLE FORMS

Sample Inspection Forms

RECEIVED

MAR - 4 2014

PA PUBLIC UTILITY COMMISSION  
SECRETARY'S BUREAU



REPORT OF MAIN AND SERVICE LINE INSPECTION

FORM 1

COMPANY: \_\_\_\_\_

This form is to be completed each time a transmission or distribution main or service line is uncovered for inspection or any other reason, such as making service connections, main extensions, replacements, etc.

DATE: \_\_\_\_\_

1. Location: \_\_\_\_\_

2. Name of Inspection: \_\_\_\_\_

3. Designation of Line: Transmission \_\_\_\_\_ Distribution \_\_\_\_\_ Service \_\_\_\_\_

4. Age of Pipe: \_\_\_\_\_ Years Line Size: \_\_\_\_\_ Inches

5. Maximum Operating Pressure: \_\_\_\_\_

6. Pipe Specification: \_\_\_\_\_

7. Cathodic Protection: \_\_\_\_\_

8. Coating: Type \_\_\_\_\_

9. External Condition: Smooth \_\_\_\_\_ Pitted \_\_\_\_\_ Depth of Pits \_\_\_\_\_

10. Internal Condition: Smooth \_\_\_\_\_ Pitted \_\_\_\_\_ Depth of Pits \_\_\_\_\_

11. Other Structures in the Area Endangering Pipeline: \_\_\_\_\_

\_\_\_\_\_

12. Condition of Right-of-Way: \_\_\_\_\_

\_\_\_\_\_

13. Corrective Measures Taken if Needed: \_\_\_\_\_

\_\_\_\_\_

14. Anodes Installed: How many? \_\_\_\_\_ Size \_\_\_\_\_ Location \_\_\_\_\_

15. Soil: Kind: Sand ( ) Clay ( ) Loam ( ) Cinders ( ) Refuse ( )

Packing: Loose ( ) Medium ( ) Hard ( )

Moisture Content: Dry ( ) Damp ( ) Wet ( )

# GAS LEAK AND REPAIR REPORT

FORM 2

COMPANY: \_\_\_\_\_

**Receipt of Report:**

Date: \_\_\_\_\_ Time: \_\_\_\_\_

Location of Leak: \_\_\_\_\_  
(address, intersection, etc.)

Reported by: \_\_\_\_\_  
(Name) (Address)

Description of Leak: \_\_\_\_\_  
(inside/outside)

Leak Detected by: \_\_\_\_\_

Leak Reported by: \_\_\_\_\_

Report Received by: \_\_\_\_\_

**Dispatched**

Date: \_\_\_\_\_ Time: \_\_\_\_\_

Investigation Assigned to: \_\_\_\_\_  
(Name)

Assigned as Immediate Action Required? Yes \_\_\_\_\_ No \_\_\_\_\_

**Investigation**

Date: \_\_\_\_\_ Time: \_\_\_\_\_

Investigation by: \_\_\_\_\_ Leak Found? Yes \_\_\_\_\_ No \_\_\_\_\_

CGI Used? Yes \_\_\_\_\_ No \_\_\_\_\_ Leak Grad: 1 \_\_\_\_\_ 2 \_\_\_\_\_ 3 \_\_\_\_\_

Location of Leak: \_\_\_\_\_

Cause of Leak: \_\_\_\_\_

Condition Made Safe: Date: \_\_\_\_\_ Time: \_\_\_\_\_

**Repair Report**

Length of Pipe Exposed: \_\_\_\_\_ feet

Leak at: Threads \_\_\_\_\_ Coupling \_\_\_\_\_ Weld (give type) \_\_\_\_\_ Valve \_\_\_\_\_ Other \_\_\_\_\_

Pipe: Size: \_\_\_\_\_ inches/Steel ( ) Plastic ( ) Cast Iron ( ) Other ( ) Depth ( )

Coating: Enamel ( ) Wrapped ( ) Galvanized ( ) Other ( )

Condition: Excellent ( ) Good ( ) Fair ( ) Poor ( )

Soil Conditions: Sand ( ) Clay ( ) Loam ( ) Other (describe) \_\_\_\_\_

Moisture: Dry \_\_\_\_\_ Damp \_\_\_\_\_ Wet \_\_\_\_\_

Repairs Made: \_\_\_\_\_

Repair Coating Type: Mastic ( ) Hot Applied Tape ( ) Other (describe) \_\_\_\_\_

Anodes Installed: How many? \_\_\_\_\_ Anode Weight \_\_\_\_\_ lbs Depth Installed \_\_\_\_\_

Repairs Made by: \_\_\_\_\_ Date \_\_\_\_\_

(Name)

Foreman: \_\_\_\_\_ Supervisor: \_\_\_\_\_

(Signature)

(Signature)

Posted by: \_\_\_\_\_ Date: \_\_\_\_\_

# GAS DISTRIBUTION INSPECTION AND LEAKAGE REPAIR

FORM 3

COMPANY: \_\_\_\_\_  
 ADDRESS: \_\_\_\_\_  
 \_\_\_\_\_  
 \_\_\_\_\_

Grade of Leak Cas  
 Grade I \_\_\_\_\_  
 Grade II \_\_\_\_\_  
 Grade III \_\_\_\_\_

**SKETCH SHOWING LEAKS LOCATED**

**METER SET**

	Meter No. _____ (if inspected)
--	-----------------------------------

**LEAK DATA**

Detected By	Collecting	Probable Source	C.G.I. Test
Mobile Flame Pack	In Building	Mainline	Gas Percent (%)
Flame Pack	Near Building	Service Line	L.E.L.
Visual/Vegetation	In Manhole	Service Tap	P.P.M.
Combustible Meter	In Soil	Valve	Negative
Odor	In Air	Meter Set	
Bar Hole	Other	Tee	

Pressure	Surface	Leak Course
Low	Lawn	Corrosion
Intermediate	Soil	Outside Force
High	Paved	Construction Defect
	Other	Material Failure
		Other

Component	Explanation	Part of System	Pipe Type	Size	Year Installed
Pipe		Main	Steel		
Valve		Service	Cast Iron		
Fitting		Meter Set	Plastic		
Drip		Customer Piping	Other		
Drip Connection		Other			
Regulator					
Other					

Pipe Condition:    Good: \_\_\_\_\_    Fair: \_\_\_\_\_    Poor: \_\_\_\_\_

Coating Condition:    Good: \_\_\_\_\_    Fair: \_\_\_\_\_    Poor: \_\_\_\_\_

Date Repaired: \_\_\_\_\_    Date Rechecked: \_\_\_\_\_

Remarks: \_\_\_\_\_  
 \_\_\_\_\_  
 \_\_\_\_\_

PATROLLING OF PIPELINE SYSTEM

FORM 4

COMPANY: \_\_\_\_\_

Period Covered: Began \_\_\_\_\_ Ended \_\_\_\_\_

Areas Covered: \_\_\_\_\_  
\_\_\_\_\_  
\_\_\_\_\_

Map References: \_\_\_\_\_  
\_\_\_\_\_  
\_\_\_\_\_

Leakage Indications Discovered (describe locations and indications, such as a condition of vegetation):  
\_\_\_\_\_  
\_\_\_\_\_  
\_\_\_\_\_

Describe any unusual conditions at highway and railroad crossings: \_\_\_\_\_  
\_\_\_\_\_  
\_\_\_\_\_

Other Factors noted which could affect present or future safety or operations of the gas system:  
\_\_\_\_\_  
\_\_\_\_\_  
\_\_\_\_\_

Follow-up (repairs, maintenance or test resulting from this inspection): \_\_\_\_\_  
\_\_\_\_\_  
\_\_\_\_\_

Comments: \_\_\_\_\_  
\_\_\_\_\_  
\_\_\_\_\_

Number of Persons in Patrol Party: \_\_\_\_\_

Signature of Person in Charge of Patrol Party: \_\_\_\_\_

Date: \_\_\_\_\_

INSPECTION REPORT FOR MOST MASTER METER SYSTEMS

FORM 5

COMPANY: \_\_\_\_\_

Name of Building: \_\_\_\_\_ Town: \_\_\_\_\_

Location: \_\_\_\_\_

Inspector(s): \_\_\_\_\_

Check List

1. Supply Main: Average pressure: \_\_\_\_\_ Location: \_\_\_\_\_

Method of Leak Test: \_\_\_\_\_

Results: \_\_\_\_\_

2. Service Line: Size: \_\_\_\_\_ Location: \_\_\_\_\_

Method of Leak Test: \_\_\_\_\_

Results: \_\_\_\_\_

Entrance Above or Below Ground? \_\_\_\_\_

Is Meter Stop Accessible and in Good Working Order? \_\_\_\_\_

3. Meter: Make: \_\_\_\_\_ Size: \_\_\_\_\_ Number: \_\_\_\_\_

Location: \_\_\_\_\_

Case and Fittings Tested for Leaks? \_\_\_\_\_

Method of Leak Test: \_\_\_\_\_

Results: \_\_\_\_\_

4. Regulators: Make: \_\_\_\_\_ Size: \_\_\_\_\_ Number: \_\_\_\_\_

Delivery Pressure: \_\_\_\_\_ Vented Properly to Outside? \_\_\_\_\_

Relief Valve: Make: \_\_\_\_\_ Size: \_\_\_\_\_

Were Regulator and Fittings Tested for Leaks? \_\_\_\_\_

Results: \_\_\_\_\_

Was there Indication of Leakage on Meter with Appliances off? \_\_\_\_\_

Signed: \_\_\_\_\_ Date: \_\_\_\_\_

REGULATOR INSPECTION REPORT

FORM 6

COMPANY: \_\_\_\_\_

Location: \_\_\_\_\_

Regulator Information

Make: \_\_\_\_\_ Type: \_\_\_\_\_

Size: \_\_\_\_\_ Office Size: \_\_\_\_\_

Pressure Rating: Inlet: \_\_\_\_\_ Outlet: \_\_\_\_\_

M.A.O.P. of System to which it is Connected: \_\_\_\_\_

Operating Pressure: Inlet: \_\_\_\_\_ Outlet: \_\_\_\_\_

Lock Up Pressure: \_\_\_\_\_

Monitoring Regulator or Relief Setting: \_\_\_\_\_

Was the Regulator Stroked (to fully open)? Yes \_\_\_\_\_ No \_\_\_\_\_

**General Condition of the Station:**

Atmospheric Corrosion: Yes \_\_\_\_\_ No \_\_\_\_\_

Support Piping Rigid: Yes \_\_\_\_\_ No \_\_\_\_\_

Station Guards: Yes \_\_\_\_\_ No \_\_\_\_\_

Area Clean of Weeds and Grass: Yes \_\_\_\_\_ No \_\_\_\_\_

Capacity at Inlet and Outlet pressure: \_\_\_\_\_

Corrections Made: \_\_\_\_\_

Remarks: \_\_\_\_\_

\_\_\_\_\_

\_\_\_\_\_

\_\_\_\_\_

Inspector: \_\_\_\_\_

Signature: \_\_\_\_\_

Date: \_\_\_\_\_

**RELIEF VALVE INSPECTION REPORT**

**FORM 7**

**COMPANY:** \_\_\_\_\_

**Location:** \_\_\_\_\_

**Relief Valve Information**

**Make:** \_\_\_\_\_ **Type:** \_\_\_\_\_

**Size:** \_\_\_\_\_ **Office Size:** \_\_\_\_\_

**Type of Loadings:**

**Spring:** \_\_\_\_\_ **Pilot:** \_\_\_\_\_ **Other:** \_\_\_\_\_

**Range:** \_\_\_\_\_

**Pressure Setting:** \_\_\_\_\_

**Connecting Pipe Size:** \_\_\_\_\_

**Vent Stack Size:** \_\_\_\_\_

**Capacity:** \_\_\_\_\_

**General Condition of:**

**Relief Valve:** \_\_\_\_\_

**Recording Gauge:** \_\_\_\_\_

**Support Piping:** \_\_\_\_\_

**General Area:** \_\_\_\_\_

**Repairs Required:** \_\_\_\_\_

**Repairs Made:** \_\_\_\_\_

**Remarks:** \_\_\_\_\_

**Inspector:** \_\_\_\_\_

**Signature:** \_\_\_\_\_

**Date:** \_\_\_\_\_



VALVE INSPECTION REPORT

FORM 9

COMPANY: \_\_\_\_\_

\*\*\*\*\*

Valve Number	Location (Form 8)	Date Inspected	Inspected By

\*\*\*\*\*

Valve Number	Location (Form 8)	Date Inspected	Inspected By

\*\*\*\*\*

Valve Number	Location (Form 8)	Date Inspected	Inspected By

\*\*\*\*\*

Valve Number	Location (Form 8)	Date Inspected	Inspected By

MONTHLY ODORIZATION REPORT

FORM 10

COMPANY: \_\_\_\_\_

Odorizer Location: \_\_\_\_\_

Month of: \_\_\_\_\_ Period: \_\_\_\_\_ to \_\_\_\_\_

Odorizer Information

Make: \_\_\_\_\_ Type: \_\_\_\_\_

Tank Capacity: \_\_\_\_\_ gal. or lb.

Brand Name of Odorant Used: \_\_\_\_\_

**Odorant Usage:**

1. Odorant in tank at First of the Month: \_\_\_\_\_

2. Odorant Added During this Month: \_\_\_\_\_

3. Total Odorant to Account for (Items 1 + 2): \_\_\_\_\_

4. Odorant in Tank at End of the Month: \_\_\_\_\_

5. Odorant Used During this Month (Items 3 - 4): \_\_\_\_\_

6. Gas Delivery this Month: \_\_\_\_\_ mmcf

7. Rate of Odorization in lbs. or gal./mmcf:

$$\frac{\text{Odorant Used in lbs./gal}}{\text{Gas Delivery in mmcf}} = \frac{\text{(Item 5)}}{\text{(Item 6)}} = \text{_____ lbs. or gals./mmcf}$$

[Note: mmcf = million cubic foot]

Superintendent/Inspector: \_\_\_\_\_

Signature: \_\_\_\_\_ Date: \_\_\_\_\_

**“Sniff Test” and/or “Odorometer Test”**  
**ODORIZATION CHECK REPORT**

FORM 11

Annual Period \_\_\_\_\_

**COMPANY:** \_\_\_\_\_

---

---

**Location:** \_\_\_\_\_

**Date:** \_\_\_\_\_

**Odor Level:** \_\_\_\_\_ **Nil**  
\_\_\_\_\_ **Barely Detectable**  
\_\_\_\_\_ **Readily Detectable**  
\_\_\_\_\_ **Strong**

**List other odors present:** \_\_\_\_\_

**Remarks: (Odorometer Reading)** \_\_\_\_\_

**Observed By:** \_\_\_\_\_

---

---

**Location:** \_\_\_\_\_

**Date:** \_\_\_\_\_

**Odor Level:** \_\_\_\_\_ **Nil**  
\_\_\_\_\_ **Barely Detectable**  
\_\_\_\_\_ **Readily Detectable**  
\_\_\_\_\_ **Strong**

**List other odors present:** \_\_\_\_\_

**Remarks: (Odorometer Reading)** \_\_\_\_\_

**Observed By:** \_\_\_\_\_

---

---

**Location:** \_\_\_\_\_

**Date:** \_\_\_\_\_

**Odor Level:** \_\_\_\_\_ **Nil**  
\_\_\_\_\_ **Barely Detectable**  
\_\_\_\_\_ **Readily Detectable**  
\_\_\_\_\_ **Strong**

**List other odors present:** \_\_\_\_\_

**Remarks: (Odorometer Reading)** \_\_\_\_\_

**Observed By:** \_\_\_\_\_

---

---

**Location:** \_\_\_\_\_

**Date:** \_\_\_\_\_

**Odor Level:** \_\_\_\_\_ **Nil**  
\_\_\_\_\_ **Barely Detectable**  
\_\_\_\_\_ **Readily Detectable**  
\_\_\_\_\_ **Strong**

**List other odors present:** \_\_\_\_\_

**Remarks: (Odorometer Reading)** \_\_\_\_\_

**Observed By:** \_\_\_\_\_

---

---

TELEPHONIC REPORT OF CUSTOMER LEAK

FORM 12

COMPANY: \_\_\_\_\_

Customer Leak Information

Time Call Received: \_\_\_\_\_ a.m./p.m. Date: \_\_\_\_\_

Name of Caller: \_\_\_\_\_ Caller's Phone Number: \_\_\_\_\_

Name of Customer if not Caller: \_\_\_\_\_

Address of Leak: \_\_\_\_\_  
\_\_\_\_\_  
\_\_\_\_\_

Nature of Complaint: Odor ( ) Blowing Gas ( ) Dead Vegetation ( )  
Other (describe): \_\_\_\_\_  
\_\_\_\_\_

Is the gas odor or sound inside the residence? Yes \_\_\_\_\_ No \_\_\_\_\_

If so, where is it located? (at the water heater, at the heating system, at the stove, in the hall, in the kitchen, etc.): \_\_\_\_\_  
\_\_\_\_\_

Is the gas odor or sound outside the residence? Yes \_\_\_\_\_ No \_\_\_\_\_

If so, where is it located? (at the meter, near the street, at the house, in the ditch, at the pool, at the gas grill, etc.): \_\_\_\_\_  
\_\_\_\_\_

How long have you been smelling or hearing the gas? \_\_\_\_\_

Will someone be home for us to check the leak? Yes \_\_\_\_\_ No \_\_\_\_\_

Leak Response Information

Time Dispatched Investigator: \_\_\_\_\_ am/p.m. Date: \_\_\_\_\_

Name of Investigator: \_\_\_\_\_

Time of Investigator Arrival at Scene of Leak: \_\_\_\_\_ a.m./p.m.

Action Taken: \_\_\_\_\_  
\_\_\_\_\_  
\_\_\_\_\_

Time of Investigator Completion at Scene of Leak: \_\_\_\_\_ a.m./p.m.

Additional Follow-up (if needed): Yes \_\_\_\_\_ No \_\_\_\_\_

If so, what type of follow-up: \_\_\_\_\_  
\_\_\_\_\_

Additional Remarks: \_\_\_\_\_  
\_\_\_\_\_  
\_\_\_\_\_

Signature of Investigator: \_\_\_\_\_

Signature of Supervisor: \_\_\_\_\_

DAILY LEAK LOG

FORM 12A

COMPANY: \_\_\_\_\_

Location: \_\_\_\_\_

Date: \_\_\_\_\_

No.	Time Received	Caller's Name Phone Number	Order Code	Address of Leak Reported Condition	Time Dispatched	Time Arrived	Tech. & No.	Action Taken	Time Compl.	Superv. Initials
1	a.m. p.m.				a.m. p.m.	a.m. p.m.			a.m. p.m.	
2	a.m. p.m.				a.m. p.m.	a.m. p.m.			a.m. p.m.	
3	a.m. p.m.				a.m. p.m.	a.m. p.m.			a.m. p.m.	
4	a.m. p.m.				a.m. p.m.	a.m. p.m.			a.m. p.m.	
5	a.m. p.m.				a.m. p.m.	a.m. p.m.			a.m. p.m.	
6	a.m. p.m.				a.m. p.m.	a.m. p.m.			a.m. p.m.	
7	a.m. p.m.				a.m. p.m.	a.m. p.m.			a.m. p.m.	
8	a.m. p.m.				a.m. p.m.	a.m. p.m.			a.m. p.m.	
9	a.m. p.m.				a.m. p.m.	a.m. p.m.			a.m. p.m.	
10	a.m. p.m.				a.m. p.m.	a.m. p.m.			a.m. p.m.	
11	a.m. p.m.				a.m. p.m.	a.m. p.m.			a.m. p.m.	
12	a.m. p.m.				a.m. p.m.	a.m. p.m.			a.m. p.m.	







PIPELINE TEST REPORT

FORM 16

OPERATING COMPANY: \_\_\_\_\_

Testing Company: \_\_\_\_\_

This form must be completed for each section of newly installed section of pipe or service line and on each service line that is disconnected from the main for any reason.

Test Data

Type of Pipe: \_\_\_\_\_

Size of Pipe: \_\_\_\_\_ inches      Length of Line: \_\_\_\_\_

Location of Line: \_\_\_\_\_

Tested with: Nitrogen ( )      Air ( )      Natural Gas ( )      Water ( )

Other (describe): \_\_\_\_\_

Time Started: \_\_\_\_\_ a.m./p.m.      Time Ended: \_\_\_\_\_ a.m./p.m.

Test Pressure Start: \_\_\_\_\_ psig

Test Pressure Stop: \_\_\_\_\_ psig

Line Loss: Yes \_\_\_\_\_ No \_\_\_\_\_ Amount Loss: \_\_\_\_\_ mcf

Reason for Line Loss: \_\_\_\_\_

Corrective Measures Taken: \_\_\_\_\_

Remarks: \_\_\_\_\_

Company Representative: \_\_\_\_\_

Signature: \_\_\_\_\_      Date: \_\_\_\_\_

## GENERAL MAINTENANCE SCHEDULE

			Jan.	Feb.	Mar.	Apr.	May	Jun.	Jul.	Aug.	Sep.	Oct.	Nov.	Dec.
1	Patrol Pipeline Systems	192.705 192.721												
2	Patrol River Crossings, Railroad and Highway Crossings	192.705 192.721												
3	Gas Leak Detection Surveys	192.723												
	Downtown and Other Business Areas	192.723												
	Distribution Mains and Services	192.723												
4	Pressure Regulating Stations	192.739												
5	Regulator Stations and Recording of Pressures	192.741												
6	Pressure Relief Valves	192.743												
7	Valve Maintenance on Distribution Lines	192.747												
8	Odorization of Gas	192.625												
9	Corrosion Control - External	192.465												
10	Corrosion Control - Atmospheric	192.481												
11	Corrosion Control - Examination	192.459	Examine and record observations anytime buried piping is exposed.											
12	Corrosion Control - Rectifiers	192.465												
13	Testing of Piping	192.501 to 192.571	Test and record new pipe installations or connections per these code sections.											

**NOTE:** Certain components of this maintenance schedule may not be applicable to some smaller "Master Meter Operators." Shade in the month you intend to perform the maintenance and post in a prominent location as a reminder.

## GENERAL MAINTENANCE SCHEDULE

			Jan.	Feb.	Mar.	Apr.	May	Jun.	Jul.	Aug.	Sep.	Oct.	Nov.	Dec.
1	Patrol Pipeline Systems	192:705 192:721												
2	Patrol River Crossings, Railroad and Highway Crossings	192:705 192:721												
3	Gas Leak Detection Surveys	192:723												
	Downtown and Other Business Areas	192:723												
	Distribution Mains and Services	192:723												
4	Pressure Regulating Stations	192:739												
5	Regulator Stations and Recording of Pressures	192:741												
6	Pressure Relief Valves	192:743												
7	Valve Maintenance on Distribution Lines	192:747												
8	Odorization of Gas	192:625												
9	Corrosion Control – External	192:465												
10	Corrosion Control – Atmospheric	192:481												
11	Corrosion Control – Examination	192:459	Examine and record observations anytime buried piping is exposed.											
12	Corrosion Control – Rectifiers	192:465												
13	Testing of Piping	192:501 to 192:571	Test and record new pipe installations or connections per these code sections.											

**NOTE:** Certain components of this maintenance schedule may not be applicable to some smaller “Master Meter Operators.” Shade in the month you intend to perform the maintenance and post in a prominent location as a reminder.

**NO SCANNED IMAGES ARE  
AVAILABLE FOR OVERSIZED  
MAPS OR PLANS**

**MAPS AND PLANS  
MAY BE VIEWED IN THE  
COMMISSION'S  
FILE ROOM**



EK039036960US

CUSTOMER USE ONLY

FROM: (PLEASE PRINT) PHONE (814) 222-2700

Pine-Rie Natural Gas  
P.O. Box 146  
Clanton, PA 16214

PAYMENT BY ACCOUNT (if applicable)

DELIVERY OPTIONS (Customer Use Only)

SIGNATURE REQUIRED  
Note: The mailer must check the "Signature Required" box if the mailer: 1) Requires the addressee's signature; OR 2) Purchases additional insurance; OR 3) Purchases COD service; OR 4) Purchases Return Receipt service.  
If the box is not checked, the Postal Service will leave the item in the addressee's mail receptacle or other secure location without attempting to obtain the addressee's signature on delivery.  
Delivery Options  
 No Saturday Delivery (delivered next business day)  
 Sunday/Holiday Delivery Required (additional fee, where available)  
\*Refer to USPS.com® or local Post Office™ for availability.

TO: (PLEASE PRINT) PHONE ( )

Rosemary Chiavetta, Sec.  
PA. PUC  
P.O. Box 3265  
NARRISBURG, MA  
ZIP + 4® (U.S. ADDRESSES ONLY)  
1 7 1 0 5 - 3 2 6 5

For pickup or USPS Tracking™, visit USPS.com or call 800-222-1811.  
\$100.00 insurance included.



PRIORITY  
★ MAIL ★  
EXPRESS™

Post Office To Addressee

ORIGIN (POSTAL SERVICE USE ONLY)

<input type="checkbox"/> 1-Day		<input type="checkbox"/> 2-Day		<input type="checkbox"/> Military		<input type="checkbox"/> DPO		
PO ZIP Code 16214	Scheduled Delivery Date (MM/DD/YY) 03/05/14	Postage \$ 32.00		Date Accepted (MM/DD/YY) 03/04/14		Scheduled Delivery Time 12:00	Insurance Fee \$	COD Fee \$
Time Accepted 1:58	<input type="checkbox"/> AM <input checked="" type="checkbox"/> PM	<input type="checkbox"/> Loss Guarantee Only		Return Receipt Fee \$		Total Postage & Fees \$ 32.00		Acceptance Employee Initials SIX
Weight 4 lbs.	<input type="checkbox"/> Flat Rate	<input type="checkbox"/> Live Shipment		<input type="checkbox"/> Sunday/Holiday Premium				

DELIVERY (POSTAL SERVICE USE ONLY)

Delivery Attempt (MM/DD/YY) 3-5	Time 11:00	Employee Signature <i>[Signature]</i>
	<input type="checkbox"/> AM <input checked="" type="checkbox"/> PM	

WRITE FIRMLY TO MAKE ALL COPIES LEGIBLE.