



411 Seventh Avenue
16th Floor
Pittsburgh, PA 15219

Tel 412-393-1541
Fax 412-393-5757
twilliams@duqlight.com

Tishekia E. Williams
Senior Counsel

February 11, 2015

Ms. Rosemary Chiavetta, Secretary
Pennsylvania Public Utility Commission
Commonwealth Keystone Building, 2nd Floor
400 North Street
Harrisburg, Pennsylvania 17120

**RE: Duquesne Light Company – Amended Application for Approval of the
Alteration of Railroad Crossing 584 673A
Docket No. A-2015-2461902**

Dear Secretary Chiavetta:

Enclosed for filing, please find an original copy of Duquesne Light Company's ("Company") amended application for approval of the alteration of the railroad crossing 584 673A located in the City of McKeesport.

The alteration of the railroad crossing consists of the replacement of two (2) existing 50' poles with 60' poles and the removal of one (1) bare solid 23kV conductor which will be replaced with three (3) bare solid 23kV conductors and one (1) 1/10 aluminum covered solid MGCN conductor. The Company requests approval of this amended application as alteration of the railroad crossing is necessary to provide appropriate distribution service to the Company's McKeesport Service Center.

If you have any questions regarding the information in this filing, please feel free to contact me.

Respectfully,

Tishekia E. Williams
Senior Counsel, Regulatory

Enclosures
cc: Certificate of Service

**BEFORE
PENNSYLVANIA PUBLIC UTILITY
COMMISSION**

**In re: Amendment of application of
Duquesne Light Company for approval
of the alteration of the crossing 584 673A
by the installation of 60' poles and 3-397
aluminum bare conductors and 1-1/0
aluminum covered solid Multi-Ground
Common Neutral ("MGCN") between
new poles where Center Street crosses at
grade the tracks of CSX located in
McKeesport in Allegheny County.**

Docket No. A-2015-2461902

**To The Pennsylvania Public Utility
Commission:**

1. The name and address of applicant.

Duquesne Light Company
411 Seventh Avenue, 16-1
Pittsburgh, Pennsylvania 15219

2. The name and address of applicant's attorney.

Tishekia E. Williams, Esq.
Duquesne Light Company
411 Seventh Avenue. 16-1
Pittsburgh, PA 15219.

3. This paragraph to contain a general statement of the nature and character of service rendered by the applicant and the corporate right to alter said crossing.

Duquesne Light Company is a public utility providing electric distribution and transmission service regulated by the Pennsylvania Public Utility Commission ("Commission"). The alterations required by Duquesne Light Company are permitted by an existing agreement with Pacific & Lake Erie Railroad dated July 18, 1918 and a supplemental agreement with CSX, also known as CSX Agreement PLE004844. The Company will execute a new agreement with CSX upon approval by the Commission of this Application to replace two poles, remove one aluminum conductor, and install one grounded common neutral wire for the purpose of installing new service to the Duquesne Light McKeesport Service Center.

4. This paragraph to contain a brief, concise statement of the nature and character of the alteration of the crossing. Reference being made to plans filed as exhibits.

Duquesne Light will replace two existing 50' poles with 60' poles and remove one bare solid

23kV conductor and replace it with three 397 aluminum bare solid 23 kV conductors and one 1/0 aluminum covered solid MGCN conductor (See Exhibit 1). These replacements are required to connect the Duquesne Light Company McKeesport Service Center with the distribution feed. Currently, the McKeesport Service Center is connected to a subtransmission system that is meant for large industrial and commercial customers. However, this customer should be classified as a small or medium commercial customer. Duquesne Light anticipates that the project will take three to four months and will begin on April 1, 2015.

- 5. This paragraph to contain the names of public utilities, municipalities, corporations, or property owners concerned in or affected by the proposed alteration of the crossing. If consent to the proposed alteration has been obtained from any municipality or department of the government of the Commonwealth of Pennsylvania, verified copies of such consent should be filed as exhibits.**

City of McKeesport, Chris House, 500 Fifth Ave., McKeesport, PA 15132

CSX, Jessica Braig, 6737 Southpoint Dr. S., Suite 100, Jacksonville, FL 32216

Union Railroad Company, Tom Priest, Transtar Inc., Penn Liberty Plaza 1, Suite 300, Pittsburgh, PA 15222

- 6. This paragraph to contain an estimate of cost of installing the facilities, a statement as to the parties which will be responsible for installing, maintaining and inspecting the facilities, and from what sources it is proposed to provide such funds.**

Duquesne Light Company has estimated the cost of the project to be \$10,000. All costs will be borne by Duquesne Light. Duquesne Light Company is responsible for installing, maintaining, and inspecting the facilities, and will also be responsible for all costs associated with the installation and provision of service from the distribution feed to the Duquesne Light McKeesport Service Center.

- 7. The alteration is necessary or proper for the following reasons:**

The proposed alteration is required in order to provide the appropriate distribution service to the Duquesne Light McKeesport Service Center. The McKeesport Service Center is currently connected to a subtransmission system, however in order to switch this customer to a more appropriate distribution service, new service must be installed from the pole at the intersection of Ridge Street and Versailles Avenue to the Duquesne Light McKeesport Service Center, approximately 4,453 feet from the Customer (See Exhibit 2). Installation of this distribution service necessitates the replacement of two poles at the railroad crossing and the replacement and installation of three 397 aluminum bare solid 23 kV conductors and one 1/0 aluminum covered solid MGCN conductor.

Wherefore, applicant prays your Honorable Commission to approve the application:

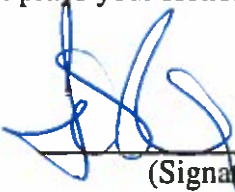

(Signature of Applicant)

TRUE LINE

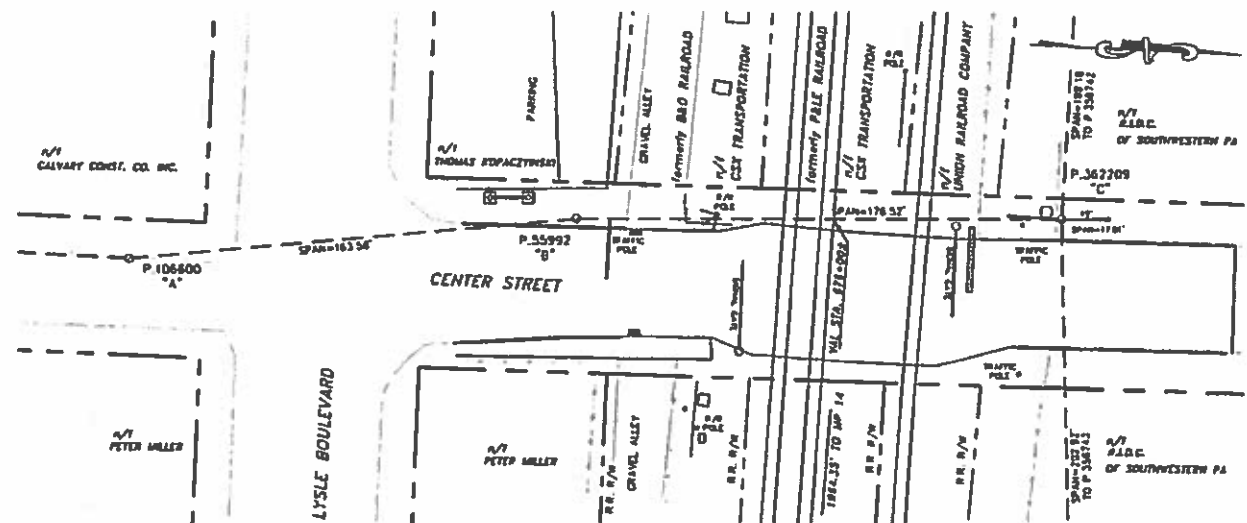
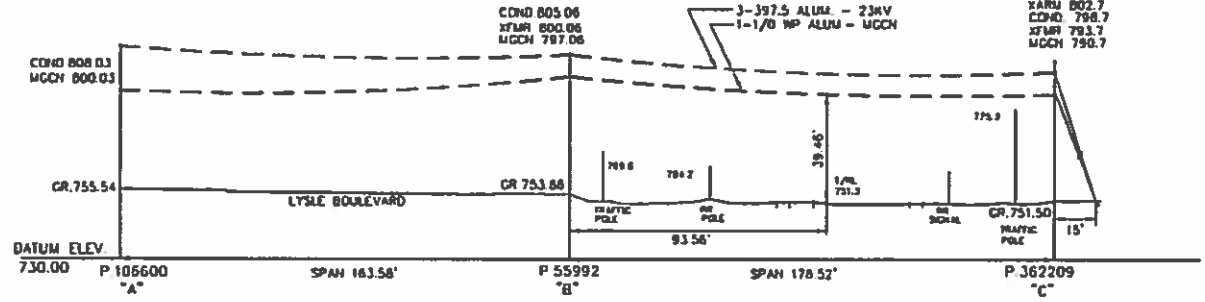
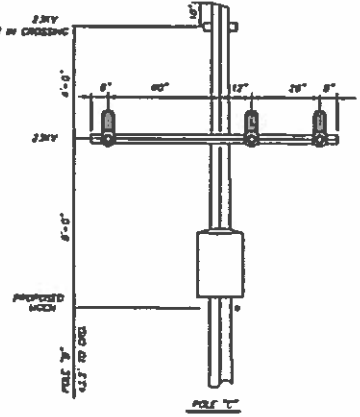
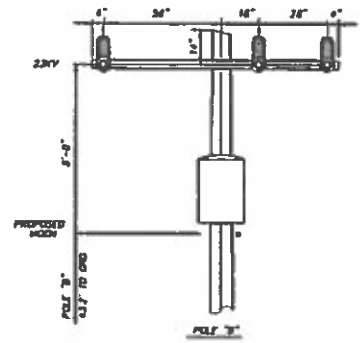

P.&L.E. MAP #5625 MP3
B.&O. MAP #1276

POLE	STRUCTURE		CONDUCTORS				TENSION	SPAN	NORMAL SAOS @ 60'	VOLTAGE		
	PRESENT	PROPOSED	CLASS	NUMBER	TYPE WIRE	SAOS ON CONVD					SOLID STRANDED	
A	60'	2	B.O.	1	3	J	397 AL.	BARE SOL.	23KV	178.52'	3.53	2.14
B	50'	60'	2	B.O.	1	1	1/0 AL.	COV. SOL.	MGCN			
C	50'	60'	2	B.O.								

NOTE: CROSSINGS ON CROSSING POLES ARE DOUBLE

FILE OR JOB NUMBER: 367593

NOTE BOOK:

DATE OF AGREEMENT:

CIRCUIT NUMBER:

LEGEND:

→	ANCHOR	→	ANCHOR
○	DLC POLE	○	DLC POLE
□	TRAF. POLE	□	TRAF. POLE

DUQUESNE LIGHT COMPANY
REAL ESTATE DEPARTMENT - SURVEYING PITTSBURGH, PA

SCALE: 1" = 20'

DATE: 10/07/14
DRAWN: RJB
CHECKED: JJJ
INSPECTED:

APPL. COMPLETE WHEN INSTALLED HERE

NOTE: THIS DWG. SUPERSEDES DWG. OF SAME NO. DATED 7/03/85

23KV CROSSING OVER C.S.X. TRANS. & UNION RR @ VAL STA. 676+00 (P.&L.E.) & 7136+75 (B.&O.)

CENTER STREET
CITY OF McKEESPORT, ALLEGHENY CO., PA

APP. COMPLETE WHEN INSTALLED HERE

D.F.E. NO. No. H-7635 - C
C.S. NO.

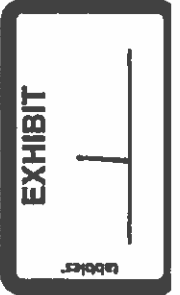

TRUE LINE



EXHIBIT
2

Google earth

feet
km

3000

RIDGE/VERSAILLES AVE TO RAILROAD TRACKS = 2,875'
(CENTER ST.)

RAILROAD TRACKS TO SERVICE CENTER = 1,578'
(CENTER ST.)



VERIFICATION

I, Russell Profaizer, being an agent of Duquesne Light Company, state that I am authorized to make this Verification on behalf of Duquesne Light Company that the facts and information set forth in the foregoing plan are true and correct to the best of my knowledge, information and belief, and I expect to be able to prove the same at any hearing held in this matter. I understand that the statements herein are made subject to the penalties of 18 Pa.C.S. § 4904 relating to unsworn falsification to authorities.



Date: February 11, 2015

Russell Profaizer, Supervisor of Distribution Engineering

CERTIFICATE OF SERVICE

I hereby certify that a true and correct copy of the foregoing has been served upon the following persons, in the manner indicated, in accordance with the requirements of 52 Pa. §1.54 (relating to service by a participant).

FIRST CLASS MAIL

Chris House
City of McKeesport
500 Fifth Avenue
McKeesport, PA 15132

Pennsylvania Department of Transportation
Office of Chief Counsel
P.O. Box 8212
Harrisburg, PA 17105-8212

Jessica Braig
CSX
6737 Southpoint Drive South
Suite 100
Jacksonville, FL 32216

Pennsylvania Department of Transportation
Engineering District 11-0
45 Thoms Run Road
Bridgeville, PA 15017

Stephen G. Shanley, Director
Allegheny County
Department of Public Works
County Office Building
542 Forbes Avenue
Room 501
Pittsburgh, PA 15219

Tom Priest
Union Railroad Company
Transtar Inc.
Penn Liberty Plaza 1
Suite 300
Pittsburgh, PA 15222

Pennsylvania Department of Transportation
ROW & Utility Division
Bureau of Design – Project Delivery
P.O. Box 3362
Harrisburg, PA 17105-3362

Date: February 11, 2015

Tishkia Williams, Esquire
Senior Counsel, Regulatory
Duquesne Light Company
411 Seventh Avenue, 16-1
Pittsburgh, PA 15222
412-393-1541
twilliams@duqlight.com