

TABLE OF CONTENTS

Attachment VIII

BUSINESS PROCESS REQUIREMENTS

| | |
|---|----------|
| SECTION 1. GENERAL BUSINESS REQUIREMENTS | 1 |
| 1.1 Procedures | 1 |
| 1.1.1 Contact with Subscribers | 1 |
| 1.1.2 Expedite, Escalation, and Disaster Procedures | 1 |
| 1.1.3 Subscriber of Record | 2 |
| 1.1.4 Work Center Interface Procedures | 2 |
| 1.2 Service Offerings | 2 |
| 1.2.1 Changes in Retail Service Offerings | 2 |
| 1.2.2 Essential Services | 3 |
| 1.2.3 Deaf and Disabled Services | 3 |
| 1.2.4 Training Support | 3 |
| 1.2.5 Carrier Identification Codes | 3 |
| SECTION 2. ORDERING AND PROVISIONING | 3 |
| 2.1 General Business Requirements | 3 |
| 2.1.1 Ordering and Provisioning Parity | 3 |
| 2.1.2 CLEC Sales and Support Center ("CSSC")/Single Point of Contact ("SPOC") | 3 |
| 2.1.3 Street Address Guide ("SAG") | 4 |
| 2.1.4 Subscriber Payment History | 4 |
| 2.1.5 Carrier Selection | 4 |
| 2.1.6 Notification to Long Distance Carrier | 4 |
| 2.1.7 Number Administration/Number Reservations | 5 |
| 2.2 Service Order Process Requirements | 6 |
| 2.2.1 OBF Compliance | 6 |
| 2.2.2 Service Migrations and New Subscriber Additions | 6 |
| 2.2.3 Cut-Over Process | 7 |
| 2.2.4 Intercept Treatment and Transfer of Service Announcements | 8 |
| 2.2.5 Desired Due Date ("DDD") | 9 |
| 2.2.6 Subscriber Premises Inspections and Installations | 9 |
| 2.2.7 Firm Order Confirmation ("FOC") | 10 |
| 2.2.8 Order Rejections | 10 |
| 2.2.9 Service Order Changes | 10 |

| | |
|---|-----------|
| 2.2.10 Jeopardy Situations | 11 |
| 2.2.11 Cooperative Testing | 11 |
| 2.2.12 Service Suspensions/Restorations | 11 |
| 2.2.13 Disconnects | 11 |
| 2.2.14 Order Completion Notification | 12 |
| 2.2.15 Fulfillment Process | 12 |
| 2.2.16 Specific Unbundling Requirements | 12 |
| 2.3 Systems Interfaces and Information Exchanges | 13 |
| 2.3.1 General Requirements | 13 |
| 2.3.2 Ordering and Provisioning for Resale Services | 14 |
| 2.3.3 Ordering and Provisioning for Unbundling | 15 |
| 2.4 Standards | 16 |
| 2.4.1 General Requirements | 16 |
| SECTION 3. BILLING AND RECORDING | 16 |
| 3.1 Billable Information and Charges | 16 |
| 3.1.1 Billable Information and Charges | 16 |
| 3.1.2 Standard Billing | 17 |
| 3.1.3 Meet-Point Billing | 18 |
| 3.1.4 Collocation | 22 |
| 3.1.5 Local Number Portability | 23 |
| 3.1.6 Electronic Transfers | 24 |
| 3.1.7 Tape or Paper Transmissions | 24 |
| 3.1.8 Payment of Charges | 24 |
| 3.1.9 Billing Dispute | 25 |
| 3.2 Standards | 26 |
| SECTION 4. PROVISION OF SUBSCRIBER USAGE DATA | 27 |
| 4.1 Procedures | 27 |
| 4.1.1 General | 27 |
| 4.1.2 Incomplete Calls | 29 |
| 4.1.3 Central Clearinghouse & Settlement (ICS/Non-ICS incollects/Outcollects) | 29 |
| 4.1.4 Lost Data | 29 |
| 4.1.5 Testing, Changes and Controls | 31 |
| 4.2 Information Exchange and Interfaces | 33 |
| 4.2.1 Core Billing Information | 33 |
| 4.2.2 Product/Service Specific | 33 |
| 4.2.3 Information Transport | 33 |
| 4.2.4 Rejected Recorded Usage Data | 34 |

| | |
|--|-----------|
| 4.2.5 Interfaces | 34 |
| 4.2.6 Formats and Characteristics | 35 |
| 4.2.7 Controls | 36 |
| 4.3 Miscellaneous | 37 |
| SECTION 5. MAINTENANCE | 37 |
| 5.1 General Requirements | 37 |
| 5.2 Systems Interfaces | 41 |
| 5.3 Standards | 42 |
| SECTION 6. MISCELLANEOUS SERVICES AND FUNCTIONS | 42 |
| 6.1 General Requirements | 42 |
| 6.1.1 Basic 911 and E911 General Requirements | 42 |
| 6.1.2 Basic 911 and E911 Additional Requirements | 47 |
| 6.1.3 Directory Assistance | 48 |
| 6.1.4 Operator Services | 50 |
| 6.1.5 Directory Assistance and Listings Service Requests | 53 |
| 6.1.6 Directory Listings General Requirements | 55 |
| 6.1.7 Directory Assistance Data | 57 |
| Exhibit A Customer Guide Page Sample | |

ATTACHMENT VIII

BUSINESS PROCESS REQUIREMENTS

Section 1. General Business Requirements

1.1 Procedures

1.1.1 Contact with Subscribers

1.1.1.1 Each Party at all times shall be the primary contact and account control for all interactions with its own subscribers regarding such Party's services purchased by the subscribers, except as otherwise agreed. A Party's subscribers shall include active subscribers as well as those for whom it has service orders pending.

1.1.1.2 With respect to a Party that may receive inquiries from the other Party's subscribers, or otherwise have opportunity for such subscriber contact, the Party shall: (i) provide mutually agreed referrals to subscribers who inquire about the other Party's services or products; (ii) not disparage or discriminate against the other Party, or its products or services; and (iii) not provide information about its own products or services during that same inquiry or subscriber contact unless asked by the subscriber.

1.1.1.3 Each Party shall protect the Proprietary Information of the other Party and the other Party's subscribers in accordance with Section 22 of Part A.

1.1.2 Expedite, Escalation, and Disaster Procedures

1.1.2.1 No later than thirty (30) days after the Effective Date of this Agreement, the Parties shall develop mutually acceptable escalation and expedite procedures which may be invoked at any point in the service ordering, provisioning, maintenance, and subscriber usage data transfer processes to facilitate rapid and timely resolution of disputes. In addition, the Parties will establish intercompany contacts lists for purposes of handling subscriber and other matters which require attention/resolution outside of normal business procedures within thirty (30) days after the Effective Date of this Agreement. Each Party shall provide to the other an updated escalation contacts list promptly following any changes thereto.

1.1.3 Subscriber of Record

1.1.3.1 Each Party shall recognize the other as the subscriber of record for all services ordered by the other Party and shall send all notices, invoices, and information which pertain to such ordered services directly to such other Party. Each Party shall provide the other Party with addresses to which such notices, invoices, and information shall be sent.

1.1.4 Work Center Interface Procedures

1.1.4.1 Bell Atlantic and MCI shall, as early as practicable, but no later than ninety (90) days, after the Effective Date of this Agreement, develop and implement work center interface procedures where appropriate for a function/business process provided by a Party. Each Party shall provide reasonable notice to the other Party of changes to its processes.

1.2 Service Offerings

1.2.1 Changes in Retail Service Offerings

1.2.1.1 Bell Atlantic shall notify MCI of any proposed changes in the terms and conditions under which Bell Atlantic offers Telecommunications Services to subscribers who are not Telecommunications Service providers or carriers, including, but not limited to, the introduction or discontinuance of any features, functions, services, promotions, or changes in retail rates. Such notification shall be by such public notice, including Tariff filings, as is required by State law or Commission rule. In addition, Bell Atlantic shall provide notification by posting such changes on Bell Atlantic's World Wide Web site within five (5) business days after the date of the public notice required by State law or Commission rule.

1.2.2 Essential Services

1.2.2.1 Bell Atlantic shall designate an access line as an essential service line ("ESL") upon MCI's request. MCI will be responsible for following National Security Emergency Preparedness ("NSEP") guidelines for designating ESL services.

1.2.3 Deaf and Disabled Services

1.2.3.1 The Parties shall cooperate to provide services necessary to serve deaf and disabled service subscribers.

1.2.4 Training Support

1.2.4.1 Each Party will provide the other Party with sufficient operational instruction to enable the purchasing Party to access any of the providing Party's operational support systems provided for elsewhere in this Agreement.

1.2.5 Carrier Identification Codes

1.2.5.1 The providing Party shall provide to the purchasing Party a list of active carrier identification codes ("CIC") and shall provide occasional updates, as required, for each of the providing Party's access tandems or functional equivalent; provided, however, that MCI shall be obligated to provide such information only for CIC codes on any MCI access tandem or functional equivalent thereof which do not appear on the most current list provided to MCI by Bell Atlantic for such access tandem or functional equivalent thereof.

Section 2. Ordering and Provisioning

2.1 General Business Requirements

2.1.1 Ordering and Provisioning Parity

2.1.1.1 During the term of this Agreement, Bell Atlantic shall provide necessary ordering and provisioning business process support as well as those technical and systems interfaces as may be required to enable MCI to provide Local Resale services and Network Elements at parity with Bell Atlantic.

2.1.2 CLEC Sales and Support Center ("CSSC")/Single Point of Contact ("SPOC")

2.1.2.1 Bell Atlantic shall provide up to three (3) CSSCs or reasonable equivalent which shall serve as MCI's SPOC for all activities involved in the ordering and provisioning of Bell Atlantic's Network Elements and Local Resale services. The SPOC shall receive orders (through an electronic interface) twenty-four (24) hours a day, seven (7) days a week.

2.1.2.2 The SPOC shall provide service during the hours of 8:30 a.m. to 4:30 p.m., EST, Monday through Friday (or such additional hours as Bell Atlantic shall provide service to its own subscribers) answered by personnel reasonably trained to answer questions and resolve problems in connection with the ordering and provisioning of Network Elements and Local Resale services.

2.1.2.3 Bell Atlantic shall provide, through electronic interfaces, provisioning and premises visit installation support for coordinated scheduling, status, and dispatch capabilities from 7:00 a.m. to other 10:00 p.m., EST, Monday through Friday, and Saturday from 7:00 a.m. to 8:00 p.m., EST, or for such additional hours as Bell Atlantic shall provide service to its own subscribers. Additional charges will be incurred for dispatches outside of Bell Atlantic's normal work days and work hours.

2.1.3 Street Address Guide ("SAG")

2.1.3.1 Commencing with the Effective Date of this Agreement, if Bell Atlantic should cease using postal information to develop and maintain its SAG, then upon terms and conditions to be mutually agreed, Bell Atlantic shall provide to MCIIm SAG data, or its equivalent, in a standard electronic format.

2.1.4 Subscriber Payment History

2.1.4.1 Neither Party shall refuse service to a potential subscriber of the other Party on the basis of the subscriber's past payment history with the providing Party, provided that the purchasing Party shall be responsible for payment to the providing Party for purchased services with respect to such subscriber regardless of the payment performance of the subscriber.

2.1.5 Carrier Selection

2.1.5.1 For Local Resale services or Network Elements, Bell Atlantic shall provide to MCIIm, when ordered by the Commission, the capability to order local service, intraLATA, and interLATA service by entering MCIIm's subscriber's choice of carrier on a single order. Bell Atlantic shall provide MCIIm with the capability to order separate interLATA and intraLATA carriers on a line or trunk (with line side treatment) basis.

2.1.5.2 Where intraLATA toll carrier selection is not implemented, Bell Atlantic agrees to provide intraLATA toll services for Local Resale and Local Switching, to resold or unbundled Switch lines provided to MCIIm. Where intraLATA toll carrier selection is implemented, Bell Atlantic will route toll calls to the appropriate carrier as designated by MCIIm.

2.1.6 Notification to Long Distance Carrier

2.1.6.1 Subject to Section 15 of Part A, Bell Atlantic agrees to notify MCIIm using OBF-approved CARE transactions, whenever an MCIIm subscriber who is provided local service through Local Resale or Local Switching changes PIC status.

2.1.6.2 Subject to Section 15 of Part A, Bell Atlantic shall support and implement new transaction code status indicators ("TCSIs") defined by OBF in support of Local Resale to enable MCIIm to provide seamless subscriber service.

2.1.6.2.1 Bell Atlantic shall implement TCSIs used in conjunction with the new local service provider ("LSP") identification code for handling account maintenance, subscriber service, and such other codes as OBF may define.

2.1.6.2.2 In addition, Bell Atlantic shall implement TCSIs used in conjunction with the new ported telephone number field to link "shadow" and ported telephone numbers in support of INP.

2.1.6.3 Bell Atlantic shall provide to MCIIm the LSP ID on purchased lists of MCIIm's PIC'd and non-PIC'd subscribers.

2.1.6.4 Bell Atlantic shall provide the ported telephone number on purchased CARE lists of MCIIm's PIC'd and non-other party's PIC'd subscribers.

2.1.7 Number Administration/Number Reservations

2.1.7.1 Until number administration functions are assumed by a neutral third-party in accordance with FCC Rules and Regulations, Bell Atlantic shall assign NXXs to MCIIm on a Non-Discriminatory Basis with no restrictions other than those imposed upon all carriers under the North American Numbering Plan or comparable conventions. In addition, Bell Atlantic shall provide activation of translations routing of MCIIm's NXXs to meet established national implementation dates. Further, Bell Atlantic shall provide MCIIm with access to abbreviated dialing codes, access arrangements for 555 line numbers, and the ability to obtain telephone numbers, including specific numbers where available, while a subscriber is on the phone with MCIIm, all at Parity. Bell Atlantic shall provide the same range of number choices to MCIIm, including choice of exchange number, as Bell Atlantic provides its own subscribers. Reservation and aging of numbers shall remain Bell Atlantic's responsibility.

2.1.7.2 Where mutually agreed, which agreement shall not be unreasonably withheld, the Parties will implement LERG reassignment for particular NXX codes.

2.1.7.3 Bell Atlantic shall accept MCIIm orders for vanity numbers and blocks of numbers for use with complex services including, but not limited to, direct inward dialing, CENTREX, and hunting arrangements, as

reasonably requested by MCIIm, in accordance with applicable Tariffs, and at Parity.

2.1.7.4 For simple services number reservations, Bell Atlantic shall provide real-time confirmation of the number reservation. For number reservations associated with complex services, Bell Atlantic shall provide confirmation of the number reservation within two (2) business days of MCIIm's request. Number reservations shall be provided in accordance with applicable Tariffs and at Parity with that provided Bell Atlantic's own subscribers.

2.2 Service Order Process Requirements

2.2.1 OBF Compliance

2.2.1.1 Subject to Section 15 of Part A and in accordance with OBF standards, Bell Atlantic and MCIIm shall generally follow the OBF-developed ordering and provisioning process standards. These include pre-order service inquiry, pre-order service inquiry response, firm order acknowledgment/rejection, firm order confirmation, and those to be developed for delay notification, completion notification, and the like. Each Party agrees to work cooperatively to implement future relevant OBF-developed processes related to ordering and provisioning.

2.2.2 Service Migrations and New Subscriber Additions

2.2.2.1 Party A shall not require a disconnect order from a subscriber, another local service provider, or any other entity, to establish Party B's local service for a subscriber and/or migrate a subscriber to Party B's local service. Party B shall be responsible for obtaining a Third-Party Verification ("TPV"), Letter of Authorization ("LOA"), or the like which satisfies FCC and Commission requirements.

2.2.2.2 With respect solely to Local Resale services available for resale hereunder, Bell Atlantic shall not disconnect any such service or associated features at any time during the migration of a subscriber to MCIIm service without the prior consent of MCIIm, unless such disconnection is necessitated by the change in service requested by MCIIm. Upon completion of such migration, MCIIm shall be responsible for payment for any such non-disconnected service as set forth in Attachment I to this Agreement.

2.2.2.3 Party A shall recognize Party B as an agent for the subscriber in coordinating the disconnection of services provided by Party A or another carrier. MCIIm shall be responsible for obtaining a TPV, LOA, or the like

which satisfies FCC requirements. In addition, when coordinated cut-over services are ordered, Bell Atlantic shall not disconnect any Bell Atlantic services provided to the Bell Atlantic subscriber until MCIIm notifies Bell Atlantic that MCIIm's service has been installed and operational, except where existing Bell Atlantic facilities are being reused.

2.2.2.4 Unless otherwise directed by MCIIm, when MCIIm orders Local Resale services or Local Switching, all trunk or telephone numbers currently associated with existing POTS services shall be retained without loss of feature capability and without loss of associated ancillary services, including, but not limited to, Directory Assistance Services and 911/E911 capability offered by Bell Atlantic, provided that MCIIm includes such features and ancillary services in its orders.

2.2.3 Cut-Over Process

The following cut-over coordination procedures shall apply for conversions of "live" Telephone Exchange Services to Unbundled Local Loops, including conversions to Unbundled Local Loops with INP, and to any other conversions that either Party determines must be coordinated to avoid a substantial risk of significant subscriber service disruption. Although written below to describe only conversions from Bell Atlantic to MCIIm, these and other mutually agreed-upon coordination procedures shall apply reciprocally for the "live" cutover of subscribers from Bell Atlantic to MCIIm and from MCIIm to Bell Atlantic. NP cut-over procedures shall be reasonably agreed by the Parties at such time as the capability has been developed.

2.2.3.1 MCIIm shall request cut-over coordination by delivering to Bell Atlantic a valid electronic transmittal service order (when available) or another mutually agreed-upon type of service order. Such service order shall be provided in accordance with industry format and specifications or such format and specifications as may be agreed to by the Parties. Within forty-eight (48) hours after Bell Atlantic's receipt of such valid service order, Bell Atlantic shall provide MCIIm the FOC date and time according to the installation time frames set forth in Section 2.5 below and for NP, Attachment VII, Section 4.2.

2.2.3.2 On each order, the Parties will agree on a cut-over time at least forty-eight (48) hours before that cut-over. Cut-over time will be defined as a fifteen (15) to thirty (30) minutes per line window within which both Parties will make telephone contact to complete the cut-over. The cut-over window for other methodologies will be agreed to by the Parties.

2.2.3.3 Within the appointed fifteen (15) to thirty (30) minute cut-over time, Bell Atlantic will call MCIIm to coordinate cut-over work and when MCIIm is reached in that interval, such work will be promptly performed.

2.2.3.4 If MCIIm requires a change in scheduling, it must contact Bell Atlantic to issue a supplement to the original order. The negotiations process to determine the date and time of cut-over will then be reinitiated as usual pursuant to Section 2.2.3.3.

2.2.3.5 If MCIIm is not ready within the appointed interval and if it had not called to reschedule the work at least two (2) hours prior to the start of the interval, MCIIm shall be liable for the non-recurring charge for such work for the missed appointment. In addition, non-recurring charges, if applicable, for the rescheduled appointment will apply.

2.2.3.6 If Bell Atlantic is not available or not ready at any time during the appointed fifteen (15) to thirty (30) minute interval, the Parties will reschedule and Bell Atlantic will waive the non-recurring charge, if applicable, for such work whenever it is performed pursuant to an agreed-upon rescheduling.

2.2.3.7 Beginning nine (9) months from the Effective Date, if unusual or unexpected circumstances prolong or extend the time required to accomplish the coordinated cut-over, the Party responsible for such circumstances is responsible for the reasonable labor charges of the other Party. Delays caused by the MCIIm subscriber are the responsibility of MCIIm.

2.2.4 Intercept Treatment and Transfer of Service Announcements

2.2.4.1 For Local Resale services, Bell Atlantic shall provide unbranded basic intercept treatment and transfer of service announcements to MCIIm's subscribers.

2.2.4.2 When an end user customer changes its service provider from one Party to the other Party and does not retain its original telephone number, the Party formerly providing service to such end user shall provide a referral announcement on the end user's former telephone number that provides the end user's new number or other appropriate information to the extent known. Referral announcements shall be provided reciprocally, free of charge to either Party or the end user to the extent the providing Party does not charge its own end user customers for such service, for the same period of time the providing Party provides its own end user customers when they change their telephone numbers.

2.2.4.3 The providing Party shall provide such basic treatment and transfer of service announcement in accordance with its normal policies and procedures for all service disconnects, suspensions, or transfers.

2.2.5 Desired Due Date ("DDD")

2.2.5.1 For services with agreed upon intervals, the purchasing Party shall select on each order the DDD consistent with agreed intervals. For services with variable intervals, the purchasing Party shall select among available due dates, obtained through an electronic interface, for specific services with variable intervals. The providing Party shall use reasonable efforts to not complete the order prior to the DDD or later than the DDD unless authorized by the purchasing Party.

2.2.5.2 If the DDD falls after the standard order completion interval (as mutually agreed by the Parties), the providing Party shall use reasonable efforts to complete the order on the DDD.

2.2.5.3 Subsequent to an initial order submission, the purchasing Party may request a new/revised due date that is earlier than the minimum defined interval. The providing Party shall use reasonable efforts to meet such date and may assess Non-Discriminatory expedite charges. The Parties agree that expedite orders are not to be used as a mechanism for routine avoidance of the standard DDD or standard interval(s) set forth in this Agreement. If (i) the providing Party does not assess an expedite charge on the purchasing Party; and (ii) based on the exercise of reasonable judgment, the providing Party determines that the purchasing Party is using expedite orders at a rate substantially in excess of the rate at which the providing Party and other parties use expedite orders on the providing Party's ordering systems, the providing Party shall immediately notify the purchasing Party at the Director level of escalation. The Parties shall immediately undertake good faith negotiations, based on each Party's data, to resolve the issue at the Director level of escalation, and, failing prompt and successful negotiations, through the complaint processes of the Commission or the FCC.

2.2.5.4 Any special or preferred scheduling options available to the providing Party shall also be available to the purchasing Party. The providing Party may assess Non-Discriminatory charges for such options.

2.2.6 Subscriber Premises Inspections and Installations

2.2.6.1 MCIIm shall perform or contract for any needs assessments, including equipment and installation requirements, at the premises of the subscriber, for the provision of MCIIm services to such subscribers.

2.2.6.2 Bell Atlantic shall notify MCIIm of any problems observed on the customer side of the NID in a timely manner. Bell Atlantic shall not relay to the customer that inside wire could have been performed during a Bell Atlantic technician's visit if the customer was a Bell Atlantic customer rather than an MCIIm customer.

2.2.7 Firm Order Confirmation ("FOC")

2.2.7.1 Subject to Section 15 of Part A, the providing Party shall provide to the purchasing Party, via an electronic interface, a FOC meeting OBF standards for each purchasing Party order, after a reasonable implementation interval from final acceptance of the particular OBF standard.

2.2.7.2 For a revised FOC, the providing Party shall provide order detail in accordance with OBF standards after a reasonable implementation interval from final acceptance of the particular OBF standard.

2.2.8 Order Rejections

2.2.8.1 The providing Party shall reject and return to the purchasing Party any order that is incomplete, internally inconsistent, or that the providing Party cannot provision due to defects, including, but not limited to, the requested due date is prior to the submission date. When MCIIm orders reach Bell Atlantic's service order processing systems, those orders will be processed or rejected at Parity.

2.2.9 Service Order Changes

2.2.9.1 If an installation or other ordered work requires a material change from the original service order, the providing Party shall call the purchasing Party in advance of performing the installation or other work to obtain authorization. The providing Party shall then provide the purchasing Party an estimate of additional labor hours and/or materials. After all installation or other work is completed, the providing Party shall promptly notify the purchasing Party of actual labor hours and/or materials used in accordance with regular service order completion processes.

2.2.9.1.1 If additional work is completed on a service order, as approved by the purchasing Party, the cost of the additional work must be reported to the purchasing Party.

2.2.9.1.2 If work on a service order is partially completed, notification shall identify the work that was performed and work remaining to be completed.

2.2.9.2 If an MCI subscriber requests a service change at the time of installation or other work being performed by Bell Atlantic on behalf of MCI, Bell Atlantic, while at the subscriber premises, shall direct the MCI subscriber to contact MCI to order such change.

2.2.10 Jeopardy Situations

2.2.10.1 The providing Party shall provide to the purchasing Party known delayed order notification prior to the committed due date, and other known delays in completing work specified on the purchasing Party's service order as detailed on the FOC, in accordance with mutually agreed procedures.

2.2.11 Cooperative Testing

2.2.11.1 Cooperative Testing shall be performed in accordance with Attachment III, Section 15.1.

2.2.11.2 Systems and Process Testing

2.2.11.2.1 The Parties shall cooperate upon request to assess whether all operational interfaces and processes are in place and functioning as intended. Testing shall simulate actual operational procedures and systems interfaces to the greatest extent possible. Either Party may request cooperative testing as it deems appropriate to assess service performance, reliability, and subscriber serviceability. The requested Party may levy time and materials charges on the requesting Party.

2.2.12 Service Suspensions/Restorations

2.2.12.1 Upon a request through a suspend/restore order, which shall comply with Applicable Law, Bell Atlantic shall suspend or restore the functionality of any Network Element or Local Resale service. Bell Atlantic shall provide restoration priority on a per Network Element or Combination basis in a manner that conforms with priorities requested by MCI, which shall comply with Applicable Law.

2.2.13 Disconnects

2.2.13.1 The providing Party shall notify the purchasing Party of any termination of service provided under this Agreement when such termination is requested by the providing Party or any third-party. Such notice shall be in a format and detail consistent with industry standards.

2.2.14 Order Completion Notification

2.2.14.1 Subject to Section 15 of Part A and when industry standards are developed for such service, and after a reasonable implementation interval, upon completion of a service order by the providing Party, the providing Party shall submit to the purchasing Party an order completion which reasonably details the work performed. Notification shall be provided in accordance with industry standards when developed. The Parties will cooperate in the interim to assure adequate notification.

2.2.15 Fulfillment Process

2.2.15.1 Each Party shall conduct all activities associated with the account fulfillment process for all of its subscribers.

2.2.16 Specific Unbundling Requirements

2.2.16.1 MCIIm may order and Bell Atlantic shall provision Network Elements either individually or in Technically Feasible Combinations. Network Elements ordered as combined shall be reasonably provisioned as combined by Bell Atlantic, unless MCIIm specifies that the Network Elements ordered in Combination be provisioned separately.

2.2.16.2 Prior to providing service in a specific geographic area or when MCIIm requires a change of network configuration, the Parties shall cooperate in planning the preparation of Network Elements and Switch translations in advance of orders for additional Network Elements from MCIIm.

2.2.16.3 For mutually-agreed Combinations of Network Elements, Network Elements that are currently connected and ordered together will not be physically disconnected, except for technical reasons.

2.2.16.4 Network Elements to be provisioned together shall be identified and ordered by MCIIm as such.

2.2.16.5 When ordering a Combination of Network Elements, MCIIm shall have the option of ordering all features, functions and capabilities of each Network Element, as they exist in Bell Atlantic's network on the Effective Date.

2.2.16.6 When MCIIm orders Network Elements, Bell Atlantic shall provision the features, functions, and capabilities of the Network Elements specified in this Agreement for such element, as reflected on MCIIm's order.

2.2.16.7 MCI and Bell Atlantic shall cooperate and coordinate activities including the sharing of relevant specifications in such a manner as to promote compatibility between and among respective service elements.

2.2.16.8 Orders for Network Elements will generally contain relevant administration, bill, contact, and subscriber information, as defined by the OBF.

2.3 Systems Interfaces and Information

2.3.1 General Requirements

2.3.1.1 Where access to operational support systems functionality is required, Bell Atlantic shall provide to MCI electronic interface(s) for transferring and receiving information and executing transactions in regards to service ordering and provisioning of Network Elements and Local Resale. Subject to Section 15 of Part A, the interface(s) shall be capable of supporting the steps in the OBF-developed ordering and provisioning process no later than April 1, 1997.

2.3.1.2 Bell Atlantic interfaces shall provide MCI with the same process and system capabilities for both residence and business ordering and provisioning at Parity.

2.3.1.3 Bell Atlantic and MCI shall agree on and implement interim solutions for Bell Atlantic interfaces within forty-five (45) days after the Effective Date of this Agreement. Such interim interface(s) shall, at a minimum, provide MCI the same functionality and level of service as is currently provided by the electronic interfaces used by Bell Atlantic for its own systems, users, or subscribers.

2.3.1.4 The foregoing interim interfaces or processes may be modified, if so agreed by MCI and Bell Atlantic, during the interim period.

2.3.1.5 Until the Party's electronic interfaces are available, the providing Party agrees that a co-carrier service center ("CSSC") or similar function will accept a purchasing Party's orders. Orders will be transmitted to the CSSC via an interface or method agreed upon by the Parties.

2.3.1.6 For territories in which Bell Atlantic provides Telephone Exchange Services, Bell Atlantic shall provide MCI with at least 1-2 months prior notification of local calling area changes, and generally publish any area code splits at least three (3) months prior to such splits going into effect.

2.3.1.7 Bell Atlantic shall provide to MCIIm, via an electronic interface, a list by end office switch of all CLASS, CENTREX and all other features and functions and shall provide updates to such list at the time new features and functions become available.

2.3.2 Ordering and Provisioning for Resale Services

2.3.2.1 Bell Atlantic shall provide to MCIIm all intraLATA (when presubscription is available) and interLATA carriers available for subscriber selection based on a valid subscriber address.

2.3.2.2 [RESERVED]

2.3.2.3 Subject to the provisions of Part A, Section 22 (Confidentiality and Publicity) and in accordance with all Applicable Law and regulations, the providing Party shall provide the requesting Party with access to CPNI of a requesting Party subscriber without requiring the requesting Party to produce a signed LOA based on the requesting Party's representation that the subscriber has authorized the requesting Party to obtain such CPNI.

2.3.2.3.1 Bell Atlantic shall provide to MCIIm an electronic interface to Bell Atlantic subscriber information systems which will allow MCIIm to obtain Bell Atlantic's current subscriber profile based on valid bill telephone number or working telephone number, including subscriber name, billing and service addresses, billed telephone number(s), and identification of features and services on the subscriber accounts, and, in response to a valid telephone number or address, allow MCIIm to obtain information on features and services available in the end office where subscriber's services are currently provisioned.

2.3.2.3.2 Until access is available via an electronic interface for subscriber profile information, MCIIm agrees that Bell Atlantic can obtain subscriber profile information in an interim manner. The Parties shall agree on and implement interim solutions for interfaces within forty-five (45) days after the Effective Date of this Agreement.

2.3.2.4 Bell Atlantic shall provide to MCIIm a list of Local Resale services, including new services and eligible trial offers and promotions, within sixty (60) days after the Effective Date of this Agreement, and shall provide updates to such information as soon as practicable after new features and functions become available.

2.3.2.5 Bell Atlantic shall provide to MCIIm mediated query-response via an electronic interface to Bell Atlantic information systems as soon as possible, but no later than April 1, 1997 to allow MCIIm to:

2.3.2.5.1 assign telephone number(s) (if the subscriber does not already have a telephone number or requests a change of telephone number);

2.3.2.5.2 schedule dispatch and installation appointments;

2.3.2.5.3 provide service availability dates; and

2.3.2.5.4 transmit status information on service orders. Until the electronic interface is available, Bell Atlantic agrees that it will provide status on service orders at the following critical intervals: acknowledgment and firm order confirmation according to interim procedures to be mutually developed.

2.3.3 Ordering and Provisioning for Unbundling

2.3.3.1 Bell Atlantic shall provide to MCIIm, upon reasonable request, a listing of available, orderable services for Network Elements.

2.3.3.2 Bell Atlantic shall provide to MCIIm upon request such engineering design and layout information for Network Elements as may be mutually agreed.

2.3.3.3 Bell Atlantic shall provide to MCIIm an electronic interface as soon as practicable after applicable OBF standards are formally accepted which will allow MCIIm to determine service due date intervals and schedule appointments.

2.3.3.4 Where applicable, Bell Atlantic shall provide to MCIIm information on charges associated with special construction. Bell Atlantic agrees that it will, as soon as practicable, notify MCIIm of any charges associated with necessary construction.

2.3.3.5 On request from MCIIm, Bell Atlantic shall provide MCIIm with results from mechanized loop tests where such tests are Technically Feasible on a time and materials basis or at Commission-approved rates, as appropriate.

2.3.3.6 Bell Atlantic shall provide MCIIm with confirmation of circuit assignments at Parity.

2.4 Standards

2.4.1 General Requirements

2.4.1.1 MCI and Bell Atlantic shall agree upon the appropriate ordering and provisioning codes to be used for Network Elements. These codes shall apply to all aspects of the unbundling of that element or Combination of elements and shall be known as data elements as defined by the Telecommunications Industry Forum Electronic Data Interchange Service Order Subcommittee ("TCIF-EDI-SOSC").

Section 3. Billing and Recording

This Section 3 describes the requirements for Bell Atlantic to bill and record charges MCI incurs when purchasing services under this Agreement, except as may be otherwise specified in this Agreement.

- - 3.1 Billable Information And Charges

3.1.1 Interim Billing

The interim billing process described herein shall commence upon the Effective Date and continue until replaced by the standard billing process described below, with such replacement by no later than the end of the third quarter 1997 for Local Resale services purchased from Bell Atlantic by MCI. With regard to Network Elements, interim billing shall commence upon the Effective Date and continue until replaced by standard Billing Operations System ("BOS") billing for such elements. Bell Atlantic shall implement the BOS release that includes Network Element billing as soon as practicable after the release is available, and will promptly inform MCI in writing if, given the nature and magnitude of that release, implementation is likely to take more than sixty (60) days after the release is made available. Notwithstanding the foregoing, with respect to unbundled loops, unbundled switching and NP, Bell Atlantic will provide MCI with an implementation date for BOS billing within ninety (90) days after the Effective Date.

3.1.1.2 Except as otherwise provided in this Section 3, Bell Atlantic will use its existing billing systems to issue bills and invoices to MCI for amounts due under this Agreement. These bills and invoices will contain a summary of account charges with component elements and/or records when applicable. The Parties acknowledge that Bell Atlantic's existing billing system does not issue bills or invoices in accordance with national industry standard specifications in all respects.

3.1.1.3 Bell Atlantic will provide MCIIm with the capability to summarize by features and functions both monthly recurring and non-recurring charges. This capability may be satisfied by use of Bell Atlantic's CD-ROM billing for Resellers. Bell Atlantic shall cooperate with MCIIm on the testing and acceptance of interim billing procedures.

3.1.1.4 The providing Party will initially identify the purchasing Party's Billing Account Numbers (BAN) (or for MCIIm, the functionally equivalent thereof) and will not change them without ten (10) days advance written notice to the purchasing Party.

3.1.1.5 The providing Party will use a minimum of two BANs per state, one for residential customers and one for business customers. The Parties acknowledge that in Bell Atlantic's billing system, only 50,000 component accounts can be on one summary bill and that a new summary bill may be created when any MCIIm master account exceeds 45,000 component accounts.

3.1.1.6 Bell Atlantic will not use the 7th or the 14th day of the month for bill closing dates.

3.1.1.7 The providing Party will use reasonable efforts to transmit paper bills to the purchasing Party within ten (10) days of the bill closing date. If the providing Party fails to transmit an invoice within the time period specified above, the payment due date for that invoice will be extended by the number of days it is late.

3.1.2 Standard Billing

3.1.2.1 The providing Party will bill services in accordance with this Section 3 and at the rates set forth in Attachment I. The providing Party will use commercially reasonable efforts to format its electronic bills in accordance with national industry standard specifications, as appropriate. These electronic bills will include a separate and unique billing code for, and the quantity of, each type of service purchased by the purchasing Party. The providing Party will jurisdictionally identify the charges on these bills wherever it has the information necessary to do so. Wherever the providing Party is unable to identify the jurisdiction of the service purchased by the purchasing Party, the Parties will jointly develop a process to determine the appropriate jurisdiction.

3.1.2.2 The providing Party will bill the purchasing Party on a monthly basis under this Agreement. These monthly bills will include all appropriate charges, credits and adjustments for the services that were

ordered, established, utilized, discontinued or performed during the relevant billing period.

3.1.2.3 The providing Party and the purchasing Party will use reasonable commercial efforts to establish the same monthly billing date ("Bill Date") for each purchasing Party account within the state. The providing Party will include the Bill Date on each invoice transmitted to the purchasing Party. The payment due date (as described in this Attachment) shall be thirty (30) calendar days after the Bill Date. The providing Party will transmit all invoices within ten (10) calendar days after the Bill Date. Any invoice transmitted on a Saturday, Sunday or a day designated as a holiday by the Parties' bill processing departments will be deemed transmitted on the next business day. If the providing Party fails to transmit an invoice within the time period specified above, the payment due date for that invoice will be extended by the number of days it is late.

3.1.2.4 The providing Party will use the same account identification numbers each month, unless it provides the purchasing Party with ten (10) days advance written notice of any change. If either Party requests an additional copy(ies) of a bill, such Party shall pay the other Party a reasonable fee per additional bill copy, unless such copy was requested due to an error or omission of the providing Party.

3.1.2.5 Except as otherwise specified in this Agreement, each Party shall be responsible for (i) all costs and expenses it incurs in complying with its obligations under this Agreement; and (ii) the development, modification, technical installation and maintenance of any systems or other infrastructure which it requires to comply with and to continue complying with its responsibilities and obligations under this Agreement.

3.1.2.6 The providing Party and purchasing Party will identify a contact person for the handling of any questions or problems that may arise during the implementation and performance of the terms and conditions of this Attachment.

3.1.3 Meet-Point Billing

3.1.3.1 For purposes of this Section 3.1.3, "Tandem Party" shall mean the Party connected to the IXC. The "End Office Party" shall mean the Party using the Tandem Party to reach the IXC. The End Office Party and the Tandem Party will utilize commercially reasonable efforts, individually and collectively, to establish meet-point billing ("MPB") arrangements to provide a Common Transport option to switched Access Services subscribers via an access Tandem Switch in accordance with the Meet-Point Billing guidelines adopted by and contained in the OSF's MECAB

and MECOD documents, except as modified herein and the Tandem Party's Tariffs. The arrangements described in this section are intended to be used to provide switched Exchange Access Service that originates and/or terminates on a Telephone Exchange Service that is provided by either Party, where the transport component of the switched Exchange Access Service is routed through a Tandem Switch that is provided by the Tandem Party.

3.1.3.2 In each LATA, the Parties shall establish MPB arrangements between the applicable rating point/the Tandem Party local serving Wire Center combinations.

3.1.3.3 Interconnection for the MPB arrangement shall occur at the applicable access tandems or functional equivalent in the LATA, unless otherwise agreed to by the Parties.

3.1.3.4 The Parties will use commercially reasonable efforts, individually and collectively, to maintain provisions in their respective federal and state access Tariffs, and/or provisions within the National Exchange Carrier Association ("NECA") Tariff No. 4, or any successor Tariff, to reflect the MPB arrangements identified in this Agreement, in MECAB and in MECOD.

3.1.3.5 Each Party will implement the "multiple bill/single tariff" or "multiple bill/multiple tariff" option, as appropriate, in order to bill any IXC for the portion of the jointly provided Access Service provided by that Party. For all traffic carried over MPB arrangements using Network Elements or interconnection services provided under this Agreement, the Parties shall bill each other all applicable rates specified in this Agreement.

3.1.3.6 The rate elements to be billed by each Party are as set forth below. The actual rate values for each Party's affected Access Service rate element shall be the rates contained in that Party's own effective federal and state access Tariffs, or other document that contains the terms under which that Party's Access Services are offered. The MPB billing percentages for each rating point/Tandem Party local serving Wire Center Combination shall be calculated in accordance with the formula set forth in subsection 3.1.3.15 below.

3.1.3.6.1 Rate Elements under Meet-Point Billing

Interstate Access - Terminating to or originating from End Office Party subscribers

| <u>Rate Element</u> | <u>Billing Company</u> |
|---|---|
| Carrier Common Line | End Office Party |
| Local Switching | End Office Party |
| Interconnection Charge | End Office Party |
| Local Transport Facility/ Tandem Switched Transport Per Mile | Based on negotiated billing percentage |
| Tandem Switching | Tandem Party |
| Local Transport Termination/ Tandem Switched Transport Fixed | Tandem Party |
| Entrance Facility | Tandem Party |
| 800 Database Query | Party that performs query |

Intrastate Access - Terminating to or originating from End Office Party subscribers (Pre-LTR tariff)

| <u>Rate Element</u> | <u>Billing Company</u> |
|---------------------|---|
| Carrier Common Line | End Office Party |
| Local Switching | End Office Party |
| Transport | Based on negotiated billing percentage |

Intrastate Access - Terminating to or originating from End Office Party subscribers (Post-LTR tariff)

| <u>Rate Element</u> | <u>Billing Company</u> |
|---|---|
| Carrier Common Line | End Office Party |
| Local Switching | End Office Party |
| Interconnection Charge | End Office Party |
| Local Transport Facility/ Tandem Switched Transport Per Mile | Based on negotiated billing percentage |
| Tandem Switching | Tandem Party |
| Local Transport Termination/ Tandem Switched Transport Fixed | Tandem Party |
| Entrance Facility | Tandem Party |
| 800 Database Query | Party that performs query |

3.1.3.7 Each Party shall provide the other Party with the billing name, billing address, and carrier identification code ("CIC") of the IXC, and identification of the IXC's local serving Wire Center in order to comply

with the MPB notification process as outlined in the MECAB document via facsimile or such other media as the Parties may agree to, all in accordance with a Party's existing offerings.

3.1.3.8 The Tandem Party will provide the End Office Party with the switched access detail usage data (category 1101XX records) on magnetic tape or via such other media as the Parties may agree to, no later than ten (10) business days of bill rendering.

3.1.3.9 The End Office Party will provide the Tandem Party with the switched access detail usage data (category 1101XX records) on magnetic tape or via such other media as the Parties may agree to, no later than ten (10) business days after the date the usage occurred.

3.1.3.10 The Parties will coordinate and exchange the billing account reference ("BAR") and billing account cross reference ("BACR") numbers or OCN, as appropriate, for the MPB arrangements described in this Agreement. Each Party will notify the other if the level of billing or other BAR/BACR elements change, resulting in a new BAR/BACR number.

3.1.3.11 Errors in MPB data exchanged by the Parties may be discovered by the End Office Party, the Tandem Party or the billable IXC. Both the End Office Party and the Tandem Party agree to provide the other Party with notification of any discovered errors as soon as practicable following such discovery. The other Party shall attempt to correct the error and resubmit the data as soon as practicable after notification. In the event the errors cannot be corrected within the time period specified above, the erroneous data shall be considered lost. If MPB data is lost due to intractable errors or otherwise, both Parties shall cooperate to reconstruct the lost data and, if such reconstruction is not possible, shall accept a reasonable estimate of the lost data based upon prior usage data. Each Party shall be responsible for any lost revenue arising from its inability to relocate lost data that is adequate to support the other Party's billing of IXCs' subscriber(s).

3.1.3.12 Neither Party will charge the other for the services rendered, or for information provided pursuant to this Section 3, except those MPB and other charges set forth herein. Both Parties will identify a contact person to handle any MPB questions or problems.

3.1.3.13 MPB will apply for all traffic bearing the 500, 900, 800/888 (to the extent provided by an IXC) or any other non-geographic NPA which may be likewise designated for such traffic in the future.

3.1.3.14 In the event a Party determines to offer Telephone Exchange Services in a LATA in which the other Party operates an access Tandem Switch, the Tandem Party shall permit and enable the End Office Party to subtend the Tandem Party access Tandem Switch(es) designated for the Tandem Party end offices in the area where the End Office Party rating points(s) associated with the NPA-NXX(s) to/from which the switched Exchange Access Services are homed. The MPB billing percentages for each new rating point/the End Office Party local serving Wire Center Combination shall be calculated according to the following formula:

$$a / (a + b) = \text{End Office Party Billing Percentage; and}$$

$$b / (a + b) = \text{Tandem Party Billing Percentage}$$

where:

a = the airline mileage between the rating point and the actual point of interconnection for the MPB arrangement; and

b = the airline mileage between the Tandem Party local serving Wire Center and the actual point of interconnection for the MPB arrangement.

The End Office Party shall inform the Tandem Party of the LATA in which it intends to offer Telephone Exchange Services and its calculation of the billing percentages which should apply for such arrangement. Within ten (10) business days of the End Office Party's delivery of notice to the Tandem Party, the Tandem Party and the End Office Party shall confirm the new rating point/Tandem Party local serving Wire Center Combination and billing percentages. Nothing in this subsection shall be construed to limit the End Office Party's ability to interconnect with the Tandem Party in additional LATAs by means of interconnection at a local serving Wire Center, to the extent that such interconnection is permitted under this Agreement.

3.1.4 Collocation

3.1.4.1 Bell Atlantic agrees to issue a separate bill to MCIIm for any Collocation capital expenditures (e.g., costs associated with building the "cage") incurred under this Agreement. Bell Atlantic will send these separate bills for Collocation capital expenses to the location specified by MCIIm. Bell Atlantic will bill all other non-capital recurring Collocation rates to MCIIm in accordance with this Section 3.

3.1.5 Local Number Portability

3.1.5.1 The providing Party agrees to track and record the purchasing Party's Interim Number Portability usage. After the Commission establishes a final competitively neutral Interim Number Portability funding mechanism and rate, the providing Party will bill the purchasing Party for the usage that accrued before the Commission's final decision. The purchasing Party agrees to pay these bills with appropriate Commission-determined interest charges, but reserves the right to challenge the accuracy of the tracking.

3.1.5.2 Under the INP arrangement in this Agreement, terminating compensation on calls to ported numbers should be received by each customer's chosen local service provider as if each call to the customer had been originally addressed by the caller to a telephone number bearing an NPA-NXX directly assigned to the customer's chosen local service provider. In order to accomplish this objective where INP is employed, the Parties shall utilize the process set forth in this Subsection 3.1.5.2 whereby terminating compensation on calls subject to INP will be passed from the Party that performs the INP to the other Party for whose subscriber the INP is provided.

3.1.5.2.1 The Parties shall individually and collectively make best efforts to track and quantify INP traffic between their networks based on the CPN of each call by identifying CPNs which are ported numbers. MCI shall charge Bell Atlantic for each minute of INP traffic at the INP traffic rate specified in Subsection 3.1.5.2.3 in lieu of any other compensation charges for terminating such traffic, except as provided in Subsection 3.1.5.2.2.

3.1.5.2.2 By the interconnection activation date within a LATA, the Parties shall jointly estimate for the prospective six (6) months, based on historic data of all traffic in the LATA, the percentages of such traffic that, if dialed to telephone numbers bearing NPA-NXXs directly assigned to MCI (as opposed to the ported number), would have been subject to: (i) local compensation ("Local Traffic"); (ii) appropriate intrastate FGD charges ("Intra Traffic"); (iii) interstate FGD charges ("Inter Traffic"); or (iv) handling as transit traffic. On the date which is six (6) months after the interconnection activation date, and thereafter on each succeeding six month anniversary of such interconnection activation date, the Parties shall establish new INP traffic percentages in the prospective six (6) month period, based on Bell Atlantic's choice of actual INP traffic percentages from the

preceding six (6) month period or historic data of all traffic in the LATA.

3.1.5.2.3 The INP traffic rate shall be equal to the sum of:

(Local Traffic percentage times the rate for local traffic transportation and termination set forth in Attachment I)

plus

(Intra Traffic percentage times MCIIm's effective intrastate FGD rates)

plus

(Inter Traffic percentage times MCIIm's effective interstate FGD rates).

MCIIm shall compensate Bell Atlantic for its billing and collection of charges for the intrastate and interstate FGD Access Services provided by MCIIm to a third-party through the greater of: (i) the difference between the intrastate and interstate FGD rates of MCIIm and Bell Atlantic; or (ii) three percent (3%) of Bell Atlantic's intrastate and interstate-FGD revenues for ported numbers. Under no circumstances shall Bell Atlantic, in performing the billing and collections service on behalf of MCIIm, be obligated to pass through more than ninety-seven percent (97%) of its FGD access charge to MCIIm in connection with any given ported call.

3.1.6 Electronic Transmissions

3.1.6.1 The providing Party agrees to transmit bills and invoices in the appropriate CABS or SECAB format electronically via Connect:Direct (formerly known as Network Data Mover) to the purchasing Party at an agreed upon location.

3.1.7 Tape or Paper Transmissions

3.1.7.1 In the event that the Connect:Direct capabilities of either Party are not available, the Parties will transmit billing information to each other via magnetic tape or paper, as agreed to by the Parties. The Parties shall cooperate in determining such alternate billing methods, when necessary.

3.1.8 Payment Of Charges

3.1.8.1 Payments of all undisputed amounts due under this Agreement shall be made in U.S. Dollars no later than the due date on an invoice or bill. At least thirty (30) days prior to the first transmission of a bill or invoice under this Agreement, the Parties shall provide each other the name and address to whom payment shall be made, including where appropriate, the respective banks, and account and routing numbers. If

such banking information changes, each Party shall provide the other Party at least sixty (60) days written notice of the change and such notice shall include the new banking information. In the event the purchasing Party receives multiple bills or invoices from the providing Party which are payable on the same date, the purchasing Party may remit one payment for the sum of all bills and invoices. Each Party shall provide the other Party with a contact person for the handling of payment questions or problems under this Agreement.

3.1.8.2 Undisputed amounts which are not paid by the due date stated on the providing Party's bill shall be subject to a late payment charge. The late payment charge shall be in the amount provided in Bell Atlantic's interstate access tariff; provided, that in the absence of an interstate access tariff late payment charge, the late payment charge shall be in an amount specified by the providing Party, which shall not exceed a rate of one and one-half percent (1.5%) of the overdue amount (including any unpaid, previously billed late payment charges) per month.

3.1.8.3 Although it is the intent of each Party as a providing Party to submit timely and accurate bills, failure by a providing Party to present bills to a purchasing Party in a timely or accurate manner shall not constitute a breach or default of this Agreement, or a waiver of a right of payment of the incurred charges, by the providing Party. Closure of a specific billing period shall occur by joint agreement of the Parties whereby the Parties agree that such billing period is closed to any further charges, analysis and financial transactions, except those resulting from an Audit or for charges due under a "true-up" of charges pursuant to Sections 3.1.5 hereunder. Closure shall take place within nine (9) months of the Bill Date. The month being closed represents those charges that were billed or should have been billed by the respective Bill Date.

3.1.9 Billing Dispute

3.1.9.1 Subject to and without waiver of any of the providing Party's rights under Section 21.3 of Part A of this Agreement, each Party agrees to notify the other Party upon the discovery of a billing dispute. In the event of a billing dispute, the Parties will endeavor to resolve the dispute within sixty (60) days of the Bill Date on which such disputed charges appear. Resolution of the dispute is expected to occur at the first level of management resulting in a recommendation for settlement of the dispute and closure of a specific billing period. If the issues are not resolved within the allotted time frame, the following resolution procedure will begin:

3.1.9.1.1 If the dispute is not resolved within sixty (60) days of the Bill Date, the dispute will be escalated to the second level of management for each of the respective Parties for resolution.

3.1.9.1.2 If the dispute is not resolved within ninety (90) days of the Bill Date, the dispute will be escalated to the third level of management for each of the respective Parties for resolution.

3.1.9.1.3 If the dispute is not resolved within one hundred and twenty (120) days of the Bill Date, the dispute will be resolved in accordance with the dispute resolution procedures set forth in Part A of this Agreement.

3.1.9.2 Upon resolution of the dispute, the relevant Party shall pay all amounts determined to have been due in accordance with Section 21.3 of Part A.

3.2 Standards

3.2.1 At least twenty (20) days prior to the providing Party transmitting a bill or invoice to the purchasing Party for the first time via electronic transmission or tape, or at least thirty (30) days prior to changing mechanized formats (i.e., from SECAB to CABS), the providing Party will transmit to the purchasing Party a test bill or invoice in the appropriate mechanized format. The providing Party will also provide to the purchasing Party the providing Party's originating or state level company code, so that it may be added to the purchasing Party's internal tables at least twenty (20) calendar days prior to testing or a change in the providing Party's originating or state level company code. The purchasing Party will notify the providing Party within the time period agreed to by the Parties if the test bill or invoice transmission fails to meet the purchasing Party's testing specifications. The Parties will work cooperatively to resolve any problems identified by the transmission of the test bill or invoice.

3.2.2 As mutually agreed upon prior to any change in existing formats or change to a different format, the providing Party shall send to the purchasing Party connectivity bill data in the appropriate mechanized format for testing to ensure that the bills can be processed and that the bills comply with the requirements of this Attachment. The providing Party agrees that it shall not send to the purchasing Party bill data in the new mechanized format until such bill data has met the testing specifications as set forth in this subsection. The providing Party shall provide the purchasing Party documentation on proposed format changes within ninety (90) days of the implementation of such changes.

3.2.3 The providing Party agrees that if it transmits data to the purchasing Party in a mechanized format, the providing Party shall also comply with the following

specifications which are not contained in CABS or SECAB guidelines, but which are necessary for the purchasing Party to process connectivity billing information and data:

3.2.3.1 The Bill Date shall not contain spaces or non-numeric values.

3.2.3.2 Each Connectivity Bill must contain at least one detail record, unless no usage has been recorded. Industry standards require that zero bills be rendered.

3.2.3.3 Any "from" date should be less than the associated "thru" date and neither date can contain spaces, unless otherwise permitted under applicable industry standards.

3.2.3.4 The invoice number must not have embedded spaces or low values.

3.2.4 The providing Party agrees to use commercially reasonable efforts to transmit to the purchasing Party accurate and current bills and invoices. If necessary beyond the provisions of this Section 3, the Parties agree to negotiate implementations of controls and processes to facilitate the transmission of accurate and current bills and invoices.

Section 4. Provision Of Subscriber Usage Data

For Local Resale and Local Switching, this Section 4 sets forth the terms and conditions for Bell Atlantic's provision of Recorded Usage Data (as defined in Section 4.1.1.3 below) to MCI in connection with the provision to MCI of Bell Atlantic's Switch-based services.

4.1 Procedures

4.1.1 General

4.1.1.1 Bell Atlantic shall use commercially reasonable efforts to comply with OBF and other standards set forth in this Section 4. To satisfy this requirement, Bell Atlantic and MCI shall mutually agree to the interpretation of any such standards referred to in this Section 4.

4.1.1.2 Bell Atlantic shall use commercially reasonable efforts to comply with Bellcore-documented EMR standards and the additional standards set forth in this Section 4 when recording and transmitting Recorded Usage Data to MCI.

4.1.1.3 Bell Atlantic shall record such Recorded Usage Data originating from MCI subscribers that Bell Atlantic records with respect to its own

customers in the ordinary course of business, using services ordered by MCI. "Recorded Usage Data" as used in this Section 4 means billing detail recorded in the normal course of business by Bell Atlantic including, but not limited to, billing detail recorded for the following categories of information:

4.1.1.3.1 Completed calls:

4.1.1.3.2 Use of CLASS/LASS/Custom features:

4.1.1.3.3 Calls to Directory Assistance where Bell Atlantic provides such service to an MCI subscriber:

4.1.1.3.4 Calls completed via Bell Atlantic's Operator Services where Bell Atlantic provides such service to MCI's subscribers:
and

4.1.1.3.5 CENTREX usage recorded by Bell Atlantic on its switches in the normal course of business.

4.1.1.4 **Retention of Records.** Bell Atlantic shall maintain a machine readable back-up copy of the message detail provided to MCI for the Recorded Usage Data described above for a minimum of forty-five (45) calendar days.

4.1.1.5 Bell Atlantic shall provide to MCI Recorded Usage Data for MCI subscribers in accordance with the terms herein. Bell Atlantic shall not submit other carrier local usage data as part of MCI Recorded Usage Data.

4.1.1.6 MCI, and not Bell Atlantic, shall bill MCI subscribers for services purchased by MCI hereunder.

4.1.1.7 For Local Resale, Bell Atlantic shall record and rate all calls to information service providers (*i.e.*, 976 service calls) and include such information on the data usage file ("DUF") provided to MCI hereunder. MCI shall bill such calls directly to its subscribers. To the extent either Party offers variable rated service (*e.g.*, 976, 554, and/or 915, as applicable), the Parties shall agree to separate arrangements for the billing and compensation of such services. With respect to unbundled Local Switching, Bell Atlantic shall record, and provide to MCI, unrated calls to information service providers (*i.e.*, 976 service calls) and include such information on the data usage file ("DUF") provided to MCI hereunder.

4.1.1.8 Bell Atlantic shall provide Recorded Usage Data to MCIIm billing locations as reasonably designated by MCIIm.

4.1.1.9 Bell Atlantic shall establish a CLEC sales and service center (CSSC) or similar function to serve as MCIIm's single point of contact to respond to MCIIm's call usage, data error, and record transmission inquiries.

4.1.1.10 Bell Atlantic shall provide MCIIm with a single point of contact, remote identifiers ("IDs"), and expected usage data volumes for each sending location.

4.1.1.11 MCIIm shall provide a single point of contact responsible for receiving usage transmitted by Bell Atlantic and receiving usage tapes from a courier service in the event of a facility outage.

4.1.1.12 Bell Atlantic shall bill MCIIm, and MCIIm shall pay such charges for Recorded Usage Data at the prices set forth in Attachment I. Billing and payment shall be in accordance with the applicable terms and conditions set forth in Attachment VIII, Section 3.

4.1.2 **Incomplete Calls.** No charges shall be assessed by Bell Atlantic for incomplete call attempts, unless Bell Atlantic assesses a charge for such incomplete call attempts to its subscribers.

4.1.3 Central Clearinghouse & Settlement (ICS/Non-ICS Incollects/Outcollects)

4.1.3.1 Bell Atlantic shall comply with clearinghouse and incollect/outcollect procedures to be determined by the Parties from time to time.

4.1.3.2 Bell Atlantic shall reasonably cooperate with MCIIm in its development of a neutral third-party in and out-collect process developed for intra-region alternately billed messages.

4.1.3.3 Bell Atlantic shall settle with MCIIm intra-region and inter-region billing exchanges relating to calling card calls, bill-to-third-party calls and collect calls.

4.1.4 Lost Data

4.1.4.1 Loss of Recorded Usage Data - MCIIm Recorded Usage Data determined to have been lost, damaged or destroyed as a result of an error or omission by Bell Atlantic in its performance of the recording function

shall, upon MCI's request, be recovered by Bell Atlantic at no charge to MCI. In the event the data cannot be recovered by Bell Atlantic, Bell Atlantic shall estimate the messages and associated revenue, with assistance from MCI, based upon the method described below. This method shall be applied on a consistent basis, subject to modifications agreed to by Bell Atlantic and MCI. This estimate shall be used to adjust amounts MCI owes Bell Atlantic for services Bell Atlantic provides in conjunction with the provision of Recorded Usage Data.

4.1.4.2 Partial Loss - Bell Atlantic shall review its daily controls to determine if data has been lost. When there has been a partial loss, actual message and minute volumes shall be reported, if possible. Where actual data are not available, a full day shall be estimated for the recording entity, as outlined in the following paragraphs. The amount of the partial loss is then determined by subtracting the data actually recorded for such day from the estimated total for such day.

4.1.4.3 Complete Loss - Estimated message and minute volumes for each loss consisting of an entire AMA tape or entire data volume due to its loss prior to or during processing, lost after receipt, degaussed before processing, receipt of a blank or unreadable tape, or lost for other causes, shall be reported.

4.1.4.4 Estimated Volumes - From message and minute volume reports for the entity experiencing the loss, Bell Atlantic shall secure message/minute counts for the four (4) corresponding days of the weeks preceding that in which the loss occurred and compute an average of these volumes.

4.1.4.5 If the day of loss is not a holiday but one (1) (or more) of the preceding corresponding days is a holiday, use additional preceding weeks in order to procure volumes for two (2) non-holidays in the previous two (2) weeks that correspond to the day of the week that is the day of the loss.

4.1.4.6 If the loss occurs on a weekday that is a holiday (except Christmas and Mother's day), Bell Atlantic shall use volumes from the two (2) preceding Sundays.

4.1.4.7 If the loss occurs on Mother's Day or Christmas day, Bell Atlantic shall use volumes from that day in the preceding year multiplied by a growth rate specified by MCI.

4.1.4.8 MCI may also request data be provided that has previously been successfully provided by Bell Atlantic to MCI. Bell Atlantic shall re-

provide such data, if available. Any charges to MCIIm will be negotiated on a case by case basis.

4.1.5 Testing, Changes and Controls

4.1.5.1 The Recorded Usage Data, EMR format, content, and transmission process shall be tested as set forth in this subsection 4.1.5 and, if necessary, as otherwise agreed by the Parties.

4.1.5.2 **Interface Testing.** The purpose of this test is to determine whether the usage records can be sent by Bell Atlantic to MCIIm and can be accepted and processed by MCIIm. Bell Atlantic shall provide a test file to MCIIm's designated regional processing center ("RPC") in the format that shall be used for Bell Atlantic's live day-to-day processing. The file shall contain one (1) full day's production usage and all potential call types. MCIIm shall also provide Bell Atlantic with the agreed-upon control reports as part of this test.

4.1.5.3 Pursuant to a separate testing agreement between the Parties, for testing purposes Bell Atlantic shall provide MCIIm with Bell Atlantic recorded, unrated usage for a minimum of five (5) consecutive days. MCIIm shall provide Bell Atlantic with the message validation reports associated with test usage.

4.1.5.4 **Test File.** Test data should be transported via industry standard on-line transmission software. In the event that courier service must be used to transport test media, the physical tape characteristics to be used are described in Subsection 4.2.3.2.

4.1.5.5 **Periodic Review.** Control procedures shall be part of the normal production interface management function. Breakdowns which impact the flow of usage data between Bell Atlantic and MCIIm shall be identified and jointly resolved as they occur. The resolution may include changes to control procedures to avoid similar problems in the future. Any changes to control procedures shall be mutually agreed upon by MCIIm and Bell Atlantic.

4.1.5.6 System and Software Changes

4.1.5.6.1 When Bell Atlantic plans to introduce any system or software changes which impact the format or content structure of the usage data feed to MCIIm, designated Bell Atlantic personnel shall notify MCIIm no less than one hundred twenty (120) calendar days before such changes are implemented, unless a shorter time

frame is mutually agreed to by the Parties, which agreement shall not be unreasonably withheld.

4.1.5.6.2 Bell Atlantic shall communicate the projected changes to MCI in reasonable detail to enable MCI to determine potential impacts on processing.

4.1.5.6.3 MCI may arrange to have its usage data tested utilizing the modified system or software when the latter are ready for testing.

4.1.5.6.4 If it is necessary for Bell Atlantic to make changes in the schedule, content or format of usage data transmitted to MCI, Bell Atlantic shall notify MCI.

4.1.5.7 Requested Software Changes

Bell Atlantic will consider reasonable requests for software changes that impact the format or content structure of the usage data feed to MCI. The Parties shall mutually agree on the terms and conditions governing any such changes that Bell Atlantic agrees to implement.

4.1.5.8 Changes to Data Exchange Controls

Bell Atlantic will provide current data exchange controls to MCI promptly following the execution of this Agreement. Bell Atlantic shall notify MCI at least ninety (90) calendar days before such changes are implemented, unless a different time frame is mutually agreed to by the Parties and such consent shall not be unreasonably withheld.

4.1.5.9 Verification Of Changes

4.1.5.9.1 Based on the detailed description of material changes furnished by Bell Atlantic, MCI and Bell Atlantic personnel shall, as appropriate:

4.1.5.9.1.1 Determine the type of change(s) to be implemented.

4.1.5.9.1.2 Develop a comprehensive test plan.

4.1.5.9.1.3 Arrange for review of modified controls, if applicable.

4.1.5.10 Introduction of Changes

4.1.5.10.1 When any applicable testing requirements have been met, designated MCI and Bell Atlantic personnel shall develop an implementation plan.

4.2 Information Exchange and Interfaces

4.2.1 Core Billing Information

4.2.1.1 Bell Atlantic shall provide MCI with unrated industry standard EMR records associated with all intraLATA toll and local usage recorded on MCI's behalf. MCI shall be given notification thirty (30) days prior to implementation of a new type and/or category of record.

4.2.1.2 Bell Atlantic shall provide to MCI rated EMR records for alternative billed calls (*e.g.*, collect and billed to third number calls) and pursuant to Section 4.1.1.7.

4.2.1.3 **Data Delivery Schedules.** Data shall be delivered to MCI by Bell Atlantic five (5) days per week unless otherwise negotiated, except for weeks containing MCI and/or Bell Atlantic Data Center holidays. Bell Atlantic and MCI shall exchange schedules of designated Data Center holidays. Bell Atlantic shall provide its transmission schedule to MCI.

4.2.2 Product/Service Specific

4.2.2.1 Bell Atlantic shall provide MCI a 42-50-01 record to support any special features star services resold by MCI.

4.2.3 Information Transport

4.2.3.1 Bell Atlantic and MCI shall jointly provide the transport facility for transmitting usage and billing data between Bell Atlantic locations and MCI locations as set forth in this Section 4.2. MCI shall be responsible for the circuit between the locations. Each Party shall be responsible for any software or hardware needed at its end of the circuit. Bell Atlantic shall transmit via NDM/Connect:Direct. In the event usage transfer cannot be accommodated by NDM because of extended (one (1) business day or longer) facility outages, Bell Atlantic shall contract for a courier service to transport the data via tape cartridge. The Party responsible for the outage shall incur the cost of transport.

4.2.3.2 Bell Atlantic shall comply with the following standards when data is transported to MCI on tape or cartridge via a courier. The data shall be in fixed or variable block format as mutually agreed by the Parties and be in the following format:

Tape: 9-track, 6250 (or 1600) BPI (Bytes per inch)

Cartridge: 38,000 BPI

LRECL: 2,472 Bytes

Parity: Odd

Character Set: Extended Binary Coded Decimal Interchange Code ("EBCDIC")

External labels: Exchange Carrier Name, Dataset Name ("DSN") and volume serial number

Internal labels: IBM Industry OS labels shall be used. They consist of a single volume label and two sets of header and trailer labels.

4.2.4 Rejected Recorded Usage Data

Any messages that cannot be rated and/or billed by MCI due to an error or omission by Bell Atlantic may be returned to Bell Atlantic via NDM. Returned messages shall be sent directly to Bell Atlantic in EMR format. Standard EMR return codes shall be utilized. Bell Atlantic shall investigate such returned records and use reasonable efforts to rectify the error or omission.

4.2.4.1 Bell Atlantic must return EMR/EMI records to Bell Atlantic's billing and collections customers with the OBF standard message reject code which indicates that Bell Atlantic no longer serves the end user and which includes the OCN/local service provider ID of the new local service provider/Reseller serving the end user.

4.2.5 Interfaces

4.2.5.1 MCI shall notify Bell Atlantic of resend requirements if a pack or entire dataset must be replaced due to pack rejection, damage in transit, dataset name failure, etc.

4.2.5.2 Notification of pack rejection shall be made by MCI within one (1) business day of processing. Bell Atlantic shall use reasonable efforts to correct and retransmit rejected packs within twenty-four (24) hours, or within an alternate timeframe negotiated on a case by case basis.

4.2.5.3 A pack shall contain a minimum of one message record or a maximum of 9,999 message records plus a pack header record and a pack trailer record. A file transmission contains a maximum of 99 packs. A

dataset shall contain a minimum of one pack. The providing Party shall provide the purchasing Party one dataset per Revenue Accounting Office ("RAO") sending location, with the agreed upon RAO OCN populated in the header and trailer records.

4.2.6 Formats and Characteristics

4.2.6.1 Rated in collect messages should be transmitted via the NDM and can be intermingled with the unrated messages. No special packing is needed.

4.2.6.2 **EMR.** Bell Atlantic shall provide Recorded Usage Data in the EMR format and by category, group and record types as specified herein, and shall be transmitted, via a direct feed, to MCI. The following is a list of EMR records that MCI can expect to receive from Bell Atlantic:

| | |
|---------------------------|--|
| Header Record | 20-21-01 |
| Trailer Record | 20-21-02 |
| Detail Records | *01-01-01, 06, 07, 08, 09, 14, 16, 17, 18, 31, 32, 35, 37, 80, 81, 82, 83, 42-50-01, 10- 01-01, 06, 08, 09, 14, 17, 18, 31, 32, 35, 37 |
| Credit Records | 03-01-01, 06, 08, 09, 14, 17, 18, 31, 32, 35, 37, 80, 81, 82. |
| Rated Credits | 41-01-01, 06, 08, 09, 14, 17, 18, 31, 32, 35, 37, 80, 81, 82. |
| Cancel Records | 51-01-01, 06, 08, 09, 14, 17, 18, 31, 32, 35, 37, 80, 81, 82. |
| Correction Records | 71-01-01, 06, 08, 09, 14, 17, 18, 31, 32, 35, 37, 80, 81, 82. |

*Category 01 is utilized for Rated Messages; Category 10 is utilized for Unrated Messages. Category 10 records are to have indicator 13 populated with a value of 5.

4.2.6.3 Bell Atlantic shall reasonably comply with the most current version of Bellcore standard practice guidelines for formatting EMR records, or any superseding industry standards.

4.2.6.4 The Interfacing Bell RAO, OCN, and remote identifiers shall be used by MCI to control invoice sequencing and each shall have its own invoice controls. The OCN shall also be used to determine where the message returns file, containing any misdirected and unguicable usage, shall be sent.

4.2.6.5 The file's record format shall be variable block, unless otherwise agreed. The size and the logical record length shall be 2472 bytes.

4.2.6.6 Bell Atlantic shall not sort Recorded Usage Data for MCIIm except upon terms and conditions that may be mutually agreed by the Parties, including additional charges for such services.

4.2.6.7 Bell Atlantic shall transmit the usage data to MCIIm using dataset naming conventions reasonably prescribed by MCIIm.

4.2.7 Controls

4.2.7.1 MCIIm shall test and certify the NDM interface to ensure the accurate receipt of Recorded Usage Data.

4.2.7.2 Header and trailer records shall be populated in positions 13-27 with the following information for MCIIm:

| Position | |
|----------|------------------------------|
| 13-14 | Invoice numbers (1-99) |
| 15-16 | Bell Co. ID number or zeroes |
| 17-19 | Interfacing Bell RAO Code |
| 20-23 | MCIIm OCN value 7299 |
| 24-27 | 0000 |

The trailer grand total record count shall be populated with total records in pack (excluding header & trailer).

4.2.7.3 **Control Reports.** MCIIm shall accept input data provided by Bell Atlantic in EMR format in accordance with the requirements and specifications detailed in Section 4. In order to ensure the overall integrity of the usage being transmitted from Bell Atlantic to MCIIm, data transfer control reports shall be provided by MCIIm. These reports shall be provided by MCIIm to Bell Atlantic on a daily or otherwise negotiated basis and reflect the results of the processing for each pack transmitted by Bell Atlantic.

4.2.7.4 **Control Reports - Distribution.** Since Bell Atlantic is receiving control reports, dataset names shall be established as mutually agreed.

4.2.7.5 **Message Validation Reports.** MCIIm shall provide once per day (or as otherwise negotiated) message validation reports to the designated Bell Atlantic system control coordinator. These reports shall be provided for all data received within Bell Atlantic Local Resale and Local

Switching feed and shall be transmitted concurrent with the daily usage file schedule.

4.2.7.6 Incollect Pack Processing. MCIm shall provide to Bell Atlantic a standard EMR report showing vital statistics and control totals for packs rejected and accepted and dropped messages. MCIm will provide this in the following report formats and control levels:

Company Name
 Reseller Total Messages processed in a pack
 Packs processed shall reflect the number of messages initially erred and accepted within a pack
 Reseller Total Packs processed

4.3 Miscellaneous

4.3.1 When requested by MCIm for law enforcement purposes, Bell Atlantic shall provide MCIm with Recorded Usage Data as soon as practicable following such request. If not available in EMR format, the Recorded Usage Data may be provided in AMA format.

4.3.2 Bell Atlantic shall include the working telephone number of the originating dial tone line on each EMR call record provided to MCIm.

4.3.3 End user subscriber usage records and station level detail records shall be in packs in accordance with EMR standards.

4.3.4 Bell Atlantic shall use its best commercially reasonable efforts to provide MCIm with Recorded Usage Data to be provided hereunder not more than three (3) business days after termination of the call for which usage data is to be provided.

Section 5. Maintenance

5.1 General Requirements

5.1.1 The Parties shall provide repair, maintenance, testing, and surveillance for all Local Resale services, interconnection, and Network Elements in accordance with the terms and conditions of this Section 5 of Attachment VIII.

5.1.2 The Parties shall cooperate with each other to meet maintenance standards for all Local Resale services, interconnection, and Network Elements ordered under this Agreement, as specified in this Section 5 of Attachment VIII. Such maintenance standards shall include, without limitation, standards for testing.

network management, call gapping, and notification of standards upgrades as they become available.

5.1.3 Bell Atlantic shall provide repair service that is at Parity in quality to that provided to Bell Atlantic subscribers; trouble calls from MCI shall receive response time priority that is at Parity to that of Bell Atlantic subscribers. MCI shall provide repair service that is at Parity in quality to that provided to MCI subscribers; trouble calls from Bell Atlantic shall receive response time priority that is at Parity to that of MCI subscribers.

5.1.4 The Parties shall provide scheduled and non-scheduled maintenance at Parity, including, without limitation, required and recommended maintenance intervals and procedures, for all Local Services, interconnection, and Network Elements under this Agreement that it currently provides for the maintenance of its own network. Each Party will provide reasonable notice of such maintenance if it is known to or is reasonably foreseeable to materially affect the other Party's subscribers.

5.1.4.1 Plans for scheduled maintenance shall include, at a minimum, the following information: description of work to be completed and date and time work is scheduled to be completed.

5.1.5 The Parties shall advise each other of all non-scheduled maintenance, testing, monitoring, and surveillance activity to be performed on any Network Element, including, without limitation, any hardware, equipment, software, or system, providing service functionality which is known or is reasonably foreseeable to materially affect the other Party's subscribers.

5.1.6 The Parties shall provide each other with a summary description of any and all network emergency restoration plans and network disaster recovery plans, however denominated, which are in place during the term of this Agreement. Such plans, if warranted by the nature thereof, shall include the following: (i) provision for notification to the other Party of the existence, location, and source of any emergency network outage reportable to the FCC that materially affects subscribers of the other Party, via fax to a single number designated by the other Party; (ii) establishment of a single point of contact responsible for initiating and coordinating the restoration of all Local Resale services, interconnection, or Network Elements; (iii) provision of status of restoration efforts and problem resolution during the restoration process, via fax to a single number designated by the other Party; (iv) reasonably equivalent priority, as between MCI subscribers and Bell Atlantic subscribers, for restoration efforts, consistent with FCC service restoration guidelines, including, without limitation, deployment of repair personnel, and use of spare parts and components on the Party's own network; and (v) a mutually-agreeable process for escalation of maintenance problems, including a complete, up-to-date list of responsible contacts, each available

twenty-four (24) hours per day, seven (7) days per week. Said plans shall be modified and updated as needed.

5.1.6.1 As identified, the Parties shall provide timely notification to each other of network outages at Parity with the notification provided to their own repair centers. Such outages may include, but are not limited to:

- 5.1.6.1.1 Central Office outages;
- 5.1.6.1.2 Facility outages such as cable cuts and repeater failures;
- 5.1.6.1.3 Commercial power outages;
- 5.1.6.1.4 Load sharing situations;
- 5.1.6.1.5 Subscriber loop outages;
- 5.1.6.1.6 Signaling network congestion; and
- 5.1.6.1.7 General network congestion.

5.1.7 Bell Atlantic and MCIIm will make reasonable efforts to minimize the number of calls misdirected to the other Party's repair bureau. Bell Atlantic and MCIIm shall establish mutually acceptable methods and procedures for the referral from Bell Atlantic to MCIIm, and vice versa, of any and all misdirected calls from subscribers requesting repair.

5.1.7.1 MCIIm and Bell Atlantic each agree to provide their own subscribers with a toll free or ordinary number to call for repair service. Bell Atlantic will accomplish this, and will assist MCIIm to accomplish this, in three stages:

(1) From the execution hereof until March 31, 1997, calls to 611 shall be answered by a voice response unit or live operator. Such unit or operator will provide a referral telephone number (provided by MCIIm) to those MCIIm customers who call this number. Such referrals shall be provided on a Non-Discriminatory basis.

(2) By April 1, 1997, calls to 611 will be answered solely by an automated announcement. This announcement will inform Bell Atlantic subscribers to call a toll free number and will inform all other subscribers to call their respective carriers. The automated announcement will not provide referral numbers. However, the Bell Atlantic toll free referral number will be answered by a voice response unit or live operator who will provide maintenance referral numbers to non-Bell Atlantic subscribers.

(3) Commencing no later than December 31, 1997, the 611 repair number will be deactivated and callers will be informed by a recorded message that it is no longer a working number, and that

they should contact their carrier directly. At all times, and on a Non-Discriminatory-basis, Bell Atlantic operators will refer callers to the repair number of their respective carriers.

5.1.8 Each Party's repair bureau shall perform the following functions in conformance with performance and service quality standards at Parity with those provided to itself when providing repair and maintenance to the other Party and the other Party's subscribers under this Agreement:

5.1.8.1 Either Party may request repairs to the other Party's network by calling the other Party's repair bureau.

5.1.8.2 Each Party shall make reasonable efforts to ensure that its repair bureau, including the electronic interface described in Section 5.2 herein, is on-line and operational twenty-four (24) hours per day, seven (7) days per week. MCI and Bell Atlantic will develop mutually agreed-upon manual processes for repair reporting in the event of unavailability or failure of the electronic interface.

5.1.8.3 Each Party's repair bureau shall provide to the other Party an "arrive by time" or "estimated time to arrive" on reported Telephone Exchange Service or Exchange Access Service trouble.

5.1.8.4 Each Party shall notify the other Party, via status screen or verbal communication, when the "arrive by time" or "estimated time to arrive" has been significantly changed or impacted by other events.

5.1.8.5 Each Party shall provide the status of repair efforts to the other Party upon reasonable request.

5.1.8.5.1 Bell Atlantic shall inform MCI of repair completion and the reason for trouble, if identified, as soon as practicable after restoration of Network Elements and any other trouble reports by MCI. Notification should be provided via electronic interface, when available.

5.1.8.5.2 When trouble is reported by a subscriber served through Network Elements, MCI will test its network (including basic unbundled loops) to identify any problems. If no problems are identified with the MCI network and/or no trouble is found in Bell Atlantic's service, MCI will open a trouble report with Bell Atlantic. Bell Atlantic shall then test its portion of the network and perform repairs, as appropriate, based on appointment availability. Each Party shall share test results and otherwise cooperate in order to resolve the trouble.

5.1.8.6 The Parties shall establish escalation procedures for trouble tickets and maintenance requests that are not resolved in a timely manner. The escalation procedures to be provided under this Agreement shall include names and telephone numbers of each Party's management personnel who are responsible for maintenance issues.

5.1.8.7 Neither Party shall perform maintenance services involving additional charges for Local Resale services, interconnection or Network Elements without advance authorization from the other Party, excluding charges for maintenance services as set forth in Attachment I, which will be billed to the Party requesting the maintenance services.

5.1.8.8 Bell Atlantic shall dispatch its technicians to MCI subscriber premises at Parity in response to reports submitted by MCI via an electronic interface established pursuant to Section 5.2 herein. The electronic interface shall have the capability of allowing MCI to receive trouble report information, access Bell Atlantic's status field and designated narratives which will contain the original test results, if applicable, and receive all applicable close out information including time of repair, work done and any charges associated with the trouble report.

5.1.8.9 Each Party shall furnish the other Party with single points of contact ("SPOC") for all communications relating to trouble tickets and maintenance requests.

5.1.8.10 Bell Atlantic agrees that MCI may call Bell Atlantic to verify Central Office features and functions as they relate to an open trouble report. Bell Atlantic agrees to work with MCI on the initial trouble report to isolate the cause of the trouble and, where possible, resolve the feature/function related trouble at that time.

5.1.9 The Parties shall exchange unique numbers to identify each initial report opened.

5.2 Systems Interfaces

5.2.1 Bell Atlantic will provide electronic interfaces (ECG and OSI) that meet OSI T-1 M-1 standards (ANSI T1-227, 1995 and ANSI T1-228, 1995 as may be amended), as gateways to allow MCI maintenance personnel and customer service representatives to perform the following functions for Local Services resold to MCI subscribers: the ability to transmit a new trouble ticket for an MCI subscriber; for all OSI electronically bonded reports, the ability to receive notification of status changes as they occur including notification of dispatch, providing MCI the ability to track current status on all open MCI subscriber trouble tickets; the ability to request an escalation and receive escalation

responses of said request: the ability to receive dispatch "arrive by time" appointment (POTS only) when the trouble is established and automatic notification of appointment changes; the ability to update trouble information; and the ability to receive all applicable time and material charges at the time of ticket closure (total by subscriber, per event) along with clearance time and description of work done. The Parties will negotiate reciprocal interfaces and procedures for maintenance of Interconnection and Network Elements. Prior to availability of electronic interfaces, Bell Atlantic shall respond to MCI's telephonic inquiries.

5.3 Standards

5.3.1 The following shall apply to premises visits by Bell Atlantic's employees and contractors:

5.3.1.1 Bell Atlantic employees or contractors shall provide to MCI subscribers a written notice of charges for work completed, if any, or notice that additional work (on access to the premises) will be necessary.

5.3.1.2 If work is not completed because of access problems, Bell Atlantic employees or contractors shall call MCI to advise it of the need for access. The report will be held for a reasonable period as "no-accessed" in Bell Atlantic's system and will be redated once new access is established with respect to the subscriber premises so that MCI can schedule a new appointment with Bell Atlantic and subscriber at the same time.

5.3.1.3 Bell Atlantic's employees or contractors shall use reasonable efforts to obtain the subscriber's signature on appropriate forms confirming any chargeable event.

Section 6. Miscellaneous Services & Functions

6.1 General Requirements

6.1.1 Basic 911 and E911 General Requirements

Basic 911 and E911 provides a caller access to the appropriate emergency service bureau by dialing a 3-digit universal telephone number (911). Basic 911 and E911 shall be provided to MCI in accordance with Sections 6.1.1 and 6.1.2 below. Notwithstanding the indemnification provisions set forth in Part A of this Agreement, Bell Atlantic's liability for indemnification resulting from third-party claims in connection with the provision of such 911 and E911 Services shall be subject to the liability limitations contained in Bell Atlantic's applicable 911 Tariffs.

6.1.1.1 E911 shall provide additional routing flexibility for 911 calls. E911 shall use subscriber data, contained in the 911 database system, to determine to which PSAP to route the call.

6.1.1.2 If available, Bell Atlantic shall offer a third type of 911 Service, 911 using SS7 (S911). All requirements for E911 as set forth herein shall also apply to S911 with the exception of the type of signaling used on the interconnection trunks from the local Switch to the S911 tandem.

6.1.1.3 Basic 911 and E911 functions provided to MCIm shall be at least at the same level Bell Atlantic provides to its subscribers for such functionality.

6.1.1.4 Basic 911 and E911 access shall be provided to MCIm in accordance with the following:

6.1.1.4.1 Bell Atlantic and MCIm shall conform to all state regulations concerning emergency services.

6.1.1.4.2 For E911, Bell Atlantic shall use its current process, as the same may be modified from time to time, to update and maintain subscriber information in the ALI/DMS data base.

6.1.1.5 If a jurisdiction has planned for overflow, then Bell Atlantic shall provide for such overflow 911 traffic to be routed to Bell Atlantic Operator Services or, at MCIm's discretion, directly to MCIm Operator Services.

6.1.1.6 Basic 911 and E911 access from the MCIm local Switch shall be provided to MCIm in accordance with the following:

6.1.1.6.1 When ordered by MCIm from Bell Atlantic, Bell Atlantic shall interconnect direct trunks from the MCIm network to the 911 PSAP, or the E911 tandems as designated by MCIm. Such trunks may alternatively be provided by MCIm.

6.1.1.6.2 In jurisdictions where Bell Atlantic has obligations under existing agreements as the primary provider of the 911 Service to a government agency, MCIm shall participate in the provision of the 911 Service as follows:

6.1.1.6.2.1 Each Party shall be responsible for those portions of the 911 Service for which it has control, including any necessary maintenance to each Party's portion of the 911 Service.

6.1.1.6.2.2 Bell Atlantic shall be responsible for maintaining the E911 database.

6.1.1.6.3 If a third party is the primary service provider to a government agency, MCIm shall negotiate separately with such third party with regard to the provision of 911 Service to the agency. All relations between such third party and MCIm are independent of this Agreement and Bell Atlantic makes no representations on behalf of the third party.

6.1.1.7 If available, Bell Atlantic shall provide to MCIm, upon request, the emergency public agency (*e.g.*, police, fire, rescue, poison, and bomb) telephone numbers linked to all NPA NXXs for the states in which MCIm provides service.

6.1.1.8 If available to Bell Atlantic and for those jurisdictions previously requested by MCIm, Bell Atlantic shall transmit to MCIm as soon as practicable all changes, alterations, modifications, and updates to the emergency public agency telephone numbers linked to all NPA NXXs. This transmission shall be electronic and be a separate feed from the subscriber listing feed.

6.1.1.9 The following are E911 database requirements:

6.1.1.9.1 If Bell Atlantic possesses an MSAG and is not prohibited from providing it to MCIm, it shall provide copies of the MSAG within three (3) business days from the time requested. Copies shall be provided on diskette, magnetic tape, or in a format suitable for use with desktop computers. Updates to the MSAG thereafter will be provided on a monthly basis.

6.1.1.9.2 MCIm shall be solely responsible for providing MCIm database records to Bell Atlantic for inclusion in Bell Atlantic's ALI database on a timely basis.

6.1.1.9.3 Bell Atlantic and MCIm shall arrange for the automated input and periodic updating on a mediated access basis of the E911 database information related to MCIm end users to replace the manual data entry process currently used. Bell Atlantic shall work cooperatively with MCIm to ensure the accuracy of the data transfer by verifying it against the MSAG provided that MCIm shall be responsible for the accuracy of information it provides Bell Atlantic. The relevant governmental jurisdiction is responsible for accuracy of the MSAG, and Bell Atlantic shall have no responsibility for accuracy of the MSAG. As soon as Technically Feasible, Bell Atlantic shall accept electronically

transmitted files or magnetic tape that conform to National Emergency Number Association ("NENA") Version #2 format for MCIIm subscribers.

6.1.1.9.3.1 MCIIm shall provide information on new subscribers to Bell Atlantic as part of the ordering process. Bell Atlantic shall update its database within two (2) business days of receiving the information from MCIIm. If Bell Atlantic detects an error in the MCIIm provided data, the data shall be returned to MCIIm within one (1) business day after the error was detected by Bell Atlantic. MCIIm shall respond to requests from Bell Atlantic to make corrections to database record errors by uploading corrected records within two (2) business days. Manual entry of the data by Bell Atlantic shall be allowed until an interface between the Parties is developed and deployed, and thereafter in the event such interface is not functioning properly. In the event of an E911 database failure, MCIIm subscriber E911 information review and entry shall be at Parity.

6.1.1.9.4 MCIIm shall assign an E911 database coordinator charged with the responsibility of forwarding MCIIm end user ALI record information to Bell Atlantic or via a third-party entity charged with the responsibility of ALI record transfer. MCIIm assumes all responsibility for the accuracy of the data that MCIIm provides to Bell Atlantic.

6.1.1.9.5 Bell Atlantic agrees to treat all data on MCIIm subscribers provided under this Agreement as Confidential Information in accordance with the terms of Section 22 of Part A and to use data on MCIIm subscribers only as provided under this Agreement.

6.1.1.9.6 Upon completion of NENA Telco Identification Code standards, Bell Atlantic shall use a Carrier Code (a NENA standard five-character field) on all ALI records received from MCIIm. The Carrier Code shall identify the carrier of record in IN? configurations. Prior to completion of the NENA standards, Bell Atlantic shall use the ACNA code obtained from Bellcore's carrier identification code assignments.

6.1.1.9.7 Bell Atlantic shall identify which ALI databases cover which states, counties or parts thereof, and identify and communicate a point of contact for each.

6.1.1.10 The following are basic 911 and E911 network requirements:

6.1.1.10.1 Bell Atlantic shall provide the number of trunks as may be ordered by MCI. These trunks shall be dedicated to routing 911 calls from MCI's Switch to a Bell Atlantic selective router.

6.1.1.10.2 Where available, Bell Atlantic shall provide the Selective Routing of E911 calls received from MCI's switching office. This consists of the ability to receive the ANI of MCI's subscriber, selectively route the call to the appropriate PSAP, and forward the subscriber's ANI to the PSAP. Bell Atlantic shall provide MCI with the appropriate common language location identifier ("CLLI") codes and specifications regarding the tandem serving area associated addresses and meet-points in the network.

6.1.1.10.3 Bell Atlantic will supply, upon MCI's request, the written exchange of pertinent data, at the Rate Center level, for the routing of basic 911 and E911 calls to the proper public safety agency.

6.1.1.10.4 MCI shall ensure that its Switches provide ANIs and the line number of the calling station that are compatible with Bell Atlantic's network.

6.1.1.10.5 Each ALI discrepancy report shall be jointly researched by Bell Atlantic and MCI. Corrective action shall be taken promptly by the responsible Party.

6.1.1.10.6 Subject to mutual agreement, Bell Atlantic shall provide MCI with written technical specifications for network interfaces, and technical specifications for database loading and maintenance pursuant to NENA Standards. Bell Atlantic shall also cooperate with MCI on reasonable requests for Rate Center information.

6.1.1.10.7 Bell Atlantic shall identify special routing arrangements to complete 911 calls.

6.1.1.10.8 Bell Atlantic shall begin restoration of E911 and/or E911 trunking facilities promptly upon notification of failure or outage. Bell Atlantic shall provide priority restoration of trunks or network outages on the same terms conditions it provides itself.

6.1.1.10.9 Bell Atlantic shall identify any special operator-assisted calling requirements to support 911.

6.1.1.10.10 Trunking shall be arranged in compliance with local emergency service requirements to minimize the likelihood of Central Office isolation due to cable cuts or other equipment failures. If there is an alternate means of transmitting a 911 call to a PSAP, in the event of an emergency, it will be available at Parity.

6.1.1.10.11 Equipment and circuits used for 911 shall be monitored at all times. Monitoring of circuits shall be done to the individual circuit level. Monitoring shall be conducted by Bell Atlantic for trunks between the tandem and all associated PSAPs.

6.1.1.10.12 Repair service shall begin promptly upon receipt of a report of a malfunction, the priority of which shall depend upon whether such malfunction impairs provision of 911 and E911 Services. Repair service includes testing and diagnostic service from a remote location, dispatch of or in-person visit(s) of personnel. Technicians shall be dispatched without unreasonable delay.

6.1.1.10.13 All 911 trunks must be capable of transmitting and receiving Baudot codes necessary to support the use of telecommunications devices for the deaf (TTY/TDDs).

6.1.2 Basic 911 and E911 Additional Requirements

6.1.2.1 All MCIIm lines that have been ported via INP shall reach the correct PSAP when 911 is dialed. Bell Atlantic shall send both the ported number and the MCIIm number (if both are received from MCIIm) to the PSAP upon an ALI request from the PSAP. The PSAP attendant shall see both numbers where the PSAP is using a standard ALI display screen and the PSAP extracts both numbers from the data that is sent. The MCIIm subscriber's directory number may be shown on the "remarks" line of the ALI record.

6.1.2.2 Bell Atlantic shall work with the appropriate government agency to provide MCIIm the ten-digit POTS number of each PSAP which subtends each Bell Atlantic selective router/911 tandem to which MCIIm is interconnected.

6.1.2.3 Bell Atlantic shall use reasonable efforts to notify MCIIm forty-eight (48) hours in advance of any scheduled testing or maintenance affecting MCIIm 911 Service, and provide notification as soon as possible of any unscheduled outage affecting MCIIm 911 Service.

6.1.2.4 MCIIm shall be responsible for reporting all errors, defects and malfunctions to Bell Atlantic. Bell Atlantic shall provide MCIIm with the point of contact for reporting errors, defects, and malfunctions in the service and shall also provide escalation contacts.

6.1.2.5 Bell Atlantic shall provide reasonable notification of any pending tandem moves, NPA splits, or scheduled maintenance outages affecting MCIIm 911 Service.

6.1.2.6 Bell Atlantic shall establish a process for handling "reverse ALI" inquiries by public safety entities.

6.1.2.7 Bell Atlantic shall establish a process for the management of NPA splits by populating the ALI database with the appropriate new NPA codes.

6.1.2.8 Bell Atlantic shall provide the ability for MCIIm to update 911 database with end user information for lines that have been ported via INP or NP.

6.1.3 Directory Assistance Service

6.1.3.1 Bell Atlantic shall provide for the routing of Directory Assistance calls (including but not limited to 411, 555-1212, NPA-555-1212) dialed by MCIIm subscribers directly to either the MCIIm Directory Assistance service platform or Bell Atlantic Directory Assistance service platform as specified by MCIIm.

6.1.3.2 MCIIm subscribers shall be provided the capability by Bell Atlantic to dial the same telephone numbers for access to MCIIm Directory Assistance that Bell Atlantic subscribers are provided to access Bell Atlantic Directory Assistance.

6.1.3.3 If MCIIm purchases from Bell Atlantic MCIIm-branded Directory Assistance service selectively routed to Bell Atlantic's Directory Assistance platform, MCIIm shall give Bell Atlantic six (6) months notice before terminating that arrangement by selectively rerouting Directory Assistance traffic to another Directory Assistance platform.

6.1.3.3.1 Bell Atlantic agrees to provide MCIIm subscribers with Directory Assistance service at Parity.

6.1.3.3.2 Bell Atlantic shall notify MCIIm in advance of any changes or enhancements to its Directory Assistance service, and

shall make available such service enhancements at Parity and on a Non-Discriminatory basis with respect to other CLECs.

6.1.3.3.3 Bell Atlantic shall provide Directory Assistance to MCI subscribers in accordance with Bell Atlantic's internal methods, procedures and standards, which shall, at a minimum, comply with applicable state regulations. Upon MCI's request, Bell Atlantic shall provide to MCI its methods and procedures for providing Directory Assistance service.

6.1.3.3.4 Bell Atlantic shall provide MCI with provisioning of Directory Assistance at Parity.

6.1.3.3.5 Service levels shall comply, at a minimum, with applicable state regulatory requirements, including those for number of rings to answer and disaster recovery options.

6.1.3.3.6 Specialized Routing

6.1.3.3.6.1 Commencing after April 1, 1997, and in conformance with the provisions of Attachment III, Section 7.2.2, Bell Atlantic shall make available to MCI branded Directory Assistance for Directory Assistance traffic originating at any Bell Atlantic Switches where Bell Atlantic has already implemented the rerouting of Directory Assistance traffic pursuant to a request from a carrier.

6.1.3.3.6.2 Where Bell Atlantic is not offering this service in response to a request from a carrier, MCI may request that a Switch offer such rerouting capability and, in conformance with the provisions of Attachment III, Section 7.2.2, Bell Atlantic shall begin implementation of such request within ninety (90) days, and complete implementation within ninety (90) days thereafter. Bell Atlantic shall fulfill such requests on a Non-Discriminatory Basis.

6.1.3.3.6.3 Bell Atlantic shall provide front end branding as reasonably specified by MCI. MCI has the option of providing its own branded recordings and related materials for branding.

6.1.3.3.7 Bell Atlantic shall provide the following minimum Directory Assistance capabilities to MCI's subscribers:

6.1.3.3.7.1 Bell Atlantic shall provide to MCI subscribers seeking Directory Assistance the same number of responses and detail of information that it provides its own subscribers.

6.1.3.3.7.2 Upon request by subscriber, call completion to the requested number for local and intraLATA toll calls shall be returned to the MCI network. Rating and billing shall be done by MCI.

6.1.3.3.7.2.1 Upon MCI's request and if Technically Feasible, Bell Atlantic shall provide blocking of Directory Assistance call completion on an ANI specific basis.

6.1.3.3.7.3 Bell Atlantic shall populate MCI listings in the Directory Assistance database in the same manner and in the same time frame as it does for Bell Atlantic subscribers.

6.1.3.3.7.4 Any information provided by a Directory Assistance automatic response unit shall be repeated the same number of times for MCI subscribers as for Bell Atlantic subscribers.

6.1.3.3.7.5 Bell Atlantic shall instruct MCI subscribers to call a toll free number for MCI customer service to request a credit. Bell Atlantic shall provide one toll free number for business subscribers and another for residential subscribers.

6.1.4 Operator Services

6.1.4.1 Bell Atlantic shall provide for the routing of 0- local, 0- and operator transfers for local Operator Services calls dialed by MCI subscribers directly to either the MCI Operator Service platform or Bell Atlantic Operator Service platform as specified by MCI and pursuant to Attachment III, Section 7.2.2.

6.1.4.2 MCI subscribers shall be provided the capability by Bell Atlantic to dial the same telephone numbers to access MCI operator service that Bell Atlantic subscribers dial to access Bell Atlantic Operator Service.

6.1.4.3 If MCIIm purchases from Bell Atlantic MCIIm-branded Operator Services selectively routed to Bell Atlantic's Operator Services platform, MCIIm shall give Bell Atlantic six (6) months notice before terminating that arrangement by selectively rerouting Operator Services traffic to another Operator Services platform.

6.1.4.3.1 Bell Atlantic agrees to provide MCIIm subscribers Operator Services and service enhancements at Parity and on a Non-Discriminatory basis.

6.1.4.3.2 Specialized Routing

6.1.4.3.2.1 Commencing after April 1, 1997, and in conformance with the provisions of Attachment III, Section 7.2.2, Bell Atlantic shall make available to MCIIm branded Operator Services for Operator Services traffic originating at any Bell Atlantic Switches where Bell Atlantic has already implemented the rerouting of Operator Services traffic pursuant to a request from a carrier.

6.1.4.3.2.2 Where Bell Atlantic is not offering this service in response to a request from a carrier, MCIIm may request that a Switch(es) offer such rerouting capability and, in conformance with the provisions of Attachment III, Section 7.2.2, Bell Atlantic shall begin implementation of such request within ninety (90) days, and complete implementation within ninety (90) days thereafter. Bell Atlantic shall fulfill such requests from carriers requesting it on a Non-Discriminatory Basis.

6.1.4.3.2.2.1 Bell Atlantic shall provide front end branding as reasonably specified by MCIIm. MCIIm has the option of providing its own branded recordings and related materials for branding.

6.1.4.3.3 Bell Atlantic shall provide the following minimum Operator Service capabilities to MCIIm subscribers at Parity.

6.1.4.3.3.1 Completion of 0- and 0- dialed local calls:

6.1.4.3.3.2 Completion of 0- intraLATA toll calls:

6.1.4.3.3.3 Completion of calls that are billed to a calling card, with the exception of calls billed to proprietary cards.

and MCI shall designate to Bell Atlantic the acceptable types of special billing:

6.1.4.3.3.4 Completion of person-to-person calls:

6.1.4.3.3.5 Completion of collect calls:

6.1.4.3.3.6 The capability for callers to bill to a third party and complete such calls:

6.1.4.3.3.7 Completion of station-to-station calls:

6.1.4.3.3.8 The processing of emergency calls:

6.1.4.3.3.9 The processing of Line Status Verification and Verification and Call Interrupt requests:

6.1.4.3.3.10 The processing of operator-assisted Directory Assistance calls:

6.1.4.3.3.11 Provision of rate quotes:

6.1.4.3.3.12 The processing of time-and-charges requests; and

6.1.4.3.3.13 The routing of 0- traffic directly to a "live" operator team.

6.1.4.3.3.14 When requested by MCI and commencing on availability, Bell Atlantic shall provide when Technically Feasible, credit on Operator Services calls as provided to Bell Atlantic subscribers or shall instruct MCI subscribers to call a toll free number for MCI customer service to request a credit. Bell Atlantic shall provide one toll free number for business subscribers and another for residential subscribers.

6.1.4.3.3.15 Caller assistance for the disabled; and

6.1.4.3.3.16 Provision of operator-assisted conference calling, when Technically Feasible.

6.1.4.4 Operator Service shall provide to the extent Technically Feasible MCI's local service rates when providing rate quote and time-and-

charges services when branding MCI services pursuant to Section 6.1.4.3.2.

6.1.4.5 Bell Atlantic shall exercise at least the same level of fraud control in providing Operator Service to MCI that Bell Atlantic provides for its own Operator Service.

6.1.4.6 Bell Atlantic shall perform billed number screening when handling collect, third party, and calling card calls, both for station-to-station and person-to-person call types.

6.1.4.7 Bell Atlantic shall refer subscriber account and other similar inquiries to the subscriber service centers reasonably designated in advance by MCI from time to time.

6.1.4.8 Line Status Verification and Call Interrupt (LSV/CI)

6.1.4.8.1 Bell Atlantic shall permit MCI to connect its local Operator Service to Bell Atlantic's LSV/CI systems to enable MCI to perform BLV/BLI services.

6.1.4.8.2 Bell Atlantic shall engineer its LSV/CI facilities to accommodate the anticipated volume of BLV/BLI requests during the busy hour. MCI may, from time to time, provide its anticipated volume of BLV/BLI requests to Bell Atlantic. In those instances when the LSV/CI systems become unavailable, Bell Atlantic shall inform MCI as soon as practicable.

6.1.4.9 Where INP is deployed and when a BLV/BLI request for a ported number is directed to a Bell Atlantic operator and the query is not successful (i.e., the request yields an abnormal result), the operator shall if Technically Feasible confirm whether the number has been ported and shall direct the request to the appropriate operator.

6.1.4.10 Bell Atlantic shall allow MCI to order provisioning of telephone line number (TLN) calling cards and billed number screening (BNS), in its LIDB, for ported numbers, as agreed by the Parties. Bell Atlantic shall continue to allow MCI reasonable access to its LIDB for this purpose.

6.1.5 Directory Assistance and Listings Service Requests

6.1.5.1 These requirements pertain to Bell Atlantic's Directory Assistance and listings service request process that enables MCI to (a) submit MCI subscriber information for inclusion in Bell Atlantic Directory

Assistance and Directory Listings databases: (b) submit MCIIm subscriber information for inclusion in published directories; and (c) provide MCIIm subscriber delivery address information to enable Bell Atlantic to fulfill directory distribution obligations.

6.1.5.1.1 Bell Atlantic shall accept orders on a real-time basis via electronic interface in accordance with OBF Directory Service request standards as soon as practicable.

6.1.5.1.2 Bell Atlantic shall migrate Directory Listing in accordance with OBF industry standards when developed.

6.1.5.1.3 Bell Atlantic shall enable MCIIm to electronically transmit multi-line listing orders.

6.1.5.1.4 Bell Atlantic shall provide MCIIm with a daily summary of completed Directory Service requests in accordance with OBF industry standards when developed.

6.1.5.1.5 To facilitate accurate order processing, Bell Atlantic shall provide to MCIIm the following information to the same extent and in the same manner and frequency as provided to Bell Atlantic customer service centers:

6.1.5.1.5.1 A matrix of NXX to Central Office:

6.1.5.1.5.2 Yellow pages heading codes:

6.1.5.1.5.3 Directory names and codes, and identification of which telephone directories are provided to which subscribers by subscriber address, NPA-NXX, or other criteria:

6.1.5.1.5.4 Listing format rules:

6.1.5.1.5.5 Listing alphabetizing rules:

6.1.5.1.5.6 Standard abbreviations acceptable for use in listings and addresses:

6.1.5.1.5.7 Titles and designations; and

6.1.5.1.5.8 A list of all available directories and their close dates.

6.1.5.1.6 Based on changes submitted by MCI_m as required by Bell Atlantic, Bell Atlantic shall update and maintain Directory Assistance and Directory Listings data for MCI_m subscribers who:

6.1.5.1.6.1 Disconnect Service:

6.1.5.1.6.2 Change carrier:

6.1.5.1.6.3 Install Service:

6.1.5.1.6.4 Change any service which affects DA information:

6.1.5.1.6.5 Specify Non-Solicitation: or

6.1.5.1.6.6 Are Non-Published, Non-Listed, or Listed.

6.1.6 Directory Listings General Requirements

6.1.6.1 This Section 6.1.6 pertains to listings published by Bell Atlantic in white/yellow pages, specialty directories or other printed or electronic formats containing such information. The provisions of this Section 6.1.6 shall apply to Bell Atlantic, and Bell Atlantic shall be responsible for compliance therewith, notwithstanding any arrangement between Bell Atlantic and another party (including an Affiliate of Bell Atlantic) whereby the other Party publishes or produces directories and associated products on Bell Atlantic's behalf.

6.1.6.2 Bell Atlantic shall include in its master subscriber system database list information for MCI_m subscribers as agreed by the Parties.

6.1.6.3 Upon receipt of written instructions from MCI_m with respect to all MCI_m subscriber listings, or from an MCI_m subscriber with respect to that subscriber's listing, Bell Atlantic shall not sell or license, nor allow any third party, the use of MCI_m subscriber listings. In the absence of such instructions, Bell Atlantic may sell or license such listings in the same manner as it does listings of Bell Atlantic subscribers. All revenues associated with the sale or license by Bell Atlantic of MCI_m subscriber listings shall be retained by Bell Atlantic. Bell Atlantic shall not disclose nor allow any third party to disclose non-listed name or address information for any purpose other than what may be necessary to complete directory distribution.

- 6.1.6.4 MCIIm subscriber listings, including State, Local, and Federal government listing, shall be interfiled with listings of Bell Atlantic and other CLEC subscribers.
- 6.1.6.5 Each MCIIm subscriber account number shall be provided the same white page basic listings that Bell Atlantic provides its subscribers.
- 6.1.6.6 Each MCIIm business subscriber account shall be provided the same yellow page basic listings that Bell Atlantic provides its subscribers.
- 6.1.6.7 Primary listings for all MCIIm subscribers shall be at Parity. Bell Atlantic shall make commercially reasonable efforts to develop a methodology to include MCIIm subscribers' listings in multiple directories covering the same geographic area at Parity.
- 6.1.6.8 As agreed by the Parties, MCIIm sales, service, billing, and repair information for business and residential subscribers, along with MCIIm logo, shall be included in the customer guide pages. The information required by this section shall be included in a form and font size substantially similar to that attached as Exhibit A of its Attachment VIII and shall be in the same section of the telephone directory in which Bell Atlantic lists its own similar information. All CLEC listings shall be placed alphabetically based on the name under which CLEC ordinarily conducts business. There shall be no charge for the basic listing contemplated by this section. However, Bell Atlantic may impose a Non-Discriminatory charge for additional enhancements or changes to this information, or for other information that Bell Atlantic may agree to include.
- 6.1.6.9 Bell Atlantic and MCIIm agree to mutually develop a process whereby MCIIm can review and correct subscriber Directory Listings.
- 6.1.6.10 Charges for additional and foreign white page listings ordered by MCIIm should be billed to MCIIm and itemized at the subscriber billing telephone number level.
- 6.1.6.11 Bell Atlantic shall distribute appropriate primary alphabetical and classified directories (white and yellow pages) to MCIIm subscribers at Parity: 1) upon establishment of new service; 2) during annual mass distribution; and 3) upon subscriber request. Bell Atlantic shall provide MCIIm its policy on the number of telephone directories provided at no charge to the customer.
- 6.1.6.12 Bell Atlantic shall permit, or ensure a third party permits, MCIIm subscribers to place orders for foreign directories on the same terms and

conditions such directories are made available to Bell Atlantic subscribers. Bell Atlantic shall provide to MCIIm the procedures, terms, and conditions for obtaining foreign telephone directories from Bell Atlantic.

6.1.6.13 Upon request, and at no charge, Bell Atlantic shall provide, or ensure a third party provides, reasonable quantities of directories for MCIIm's internal use to cover areas in which MCIIm is an authorized CLEC.

6.1.6.14 The directory cover shall state that it includes listings for all local telephone companies.

6.1.6.15 Bell Atlantic shall make available current recycling services to MCIIm subscribers under the same terms and conditions that Bell Atlantic makes such services available to its own subscribers.

6.1.7 Directory Assistance Data

6.1.7.1 To the extent required under Applicable Law, Bell Atlantic will provide MCIIm with "Direct Access" service to the same Directory Assistance ("DA") Database that is used by Bell Atlantic to provide Directory Assistance to Bell Atlantic customers. To the extent required by Applicable Law, if other access methods are developed by Bell Atlantic, such will be made available to MCIIm at Parity. Direct Access will enable MCIIm's operator bureau to obtain direct electronic access to the DA Database for the purpose of providing intraLATA Directory Assistance to MCIIm customers. MCIIm may search and read DA Database information at the per query rates specified in Table 1 of Attachment I. Bell Atlantic will furnish ports for connection and termination of MCIIm's facilities to the DA Database system. The type of ports and associated charges will be based on the type of access configuration required by MCIIm for termination of its facilities. The number of ports provided at the DA Database will be based on MCIIm's annual forecast of "busy hour" queries. At the request of MCIIm, Bell Atlantic will also accept electronic transmission of MCIIm Customer DA information for inclusion in the DA Database.

EXHIBIT A

Bell Atlantic

WHITE PAGES

Philadelphia

Area Code 215

September August
1996 - 1997



ADVANCING QUALITY IN IMPROVING EDUCATION, HEALTH CARE AND
DEVELOPMENT THROUGHOUT PENNSYLVANIA

Recycle Your Old Phone Books

For details see the Recycling Pages in the Customer O

Other Telephone Companies



Eastern TeleLogic Corporation
A Comcast Affiliate

Eastern TeleLogic Corporation

Main Number 610-382-2000
 Repair 888-ETCS-NCC (382-7622)
 Customer Service 800-959-5444
 Sales Information 888-272-0500

Pennsylvania TRS

Text Telephone 800-654-59
 Voice 800-654-59



MCI Business Customers

Local Sales, Service, Billing & Repair 800-374-6400

MCI Business Customers

Billing and Payment Information 800-374-640

MCI Residential Customers

Local Sales, Service, Billing & Repair 800-274-5565

MCI Residential Customers

You may pay your bill by sending your check and the remittance stub to:
 MCI
 P.O. Box 841199
 Dallas, TX 75284-1199



MFS Intelenet Companies

Local Sales Office 610-617-6000
 Customer Service, Repair and Billing 800-936-MFS (6374)

Customer Billing Mailing Address:
 MFS Intelenet, Inc.
 P.O. Box 8500-1590
 Philadelphia, PA 19178-1590

MFS Telecom Companies

Local Sales Office 215-977-850
 Customer Service and Billing 800-936-MFS (6374)

Repair 800-MFS-CIT (637-248)

Customer Billing Mailing Address:
 MFS Telephone
 Dept. 32310
 P.O. Box 7413
 Chicago, IL 60680-7413

TABLE OF CONTENTS

**Attachment IX
SECURITY REQUIREMENTS**

| | | |
|------------|---------------------------|--------|
| Section 1. | Physical Security | IX - 1 |
| Section 2. | Network Security | IX - 2 |
| Section 3. | Revenue Protection | IX - 2 |
| Section 4. | Law Enforcement Interface | IX - 3 |

ATTACHMENT IX

SECURITY REQUIREMENTS

Section 1. Physical Security

This Section 1 sets forth security requirements for physical Collocation at Bell Atlantic's premises. Each Party shall take reasonable steps to protect the other's personnel and property, including the following:

1.1 MCI shall access only equipment owned by MCI and shall enter only those areas of Bell Atlantic's premises where such equipment is located. Bell Atlantic shall maintain a log of its employees and agents that enter these areas. Bell Atlantic shall allow MCI, after reasonable advance notice, to inspect areas that house or contain MCI equipment or equipment enclosures in accordance with mutually acceptable procedures.

1.2 MCI shall deliver to Bell Atlantic within thirty (30) days of the date of this Agreement and every sixty (60) days thereafter a current list of its employees and agents authorized to enter Bell Atlantic's premises. While on Bell Atlantic's premises, such employees or agents shall prominently display identification badges. If requested by Bell Atlantic, MCI shall provide this information in an electronic format.

1.3 Each Party shall, while on the other's premises or in areas on its premises designated solely for the other Party's use, comply with the other's generally applicable security and safety procedures and requirements as may be provided from time to time by the other Party (including but not limited to sign-in, identification, and escort requirements); provided, however, that MCI's procedures and requirements for access to its equipment areas shall be consistent with those established by Bell Atlantic for the relevant premises.

1.4 Neither Party shall tamper with or perform any activities upon the other's equipment located on its premises, except as necessary to perform this Agreement (e.g., equipment maintenance, installation, etc.) or in case of emergency. In an emergency, the affected Party shall promptly notify the other of the emergency, take steps it deems appropriate to manage the emergency (using reasonable care under the circumstances to protect the other's equipment), and allow the other Party to access its premises (subject to the requirements of this Section 1) to protect its equipment.

1.5 MCI shall ensure that areas that house MCI's equipment are adequately secured to prevent unauthorized entry. Bell Atlantic shall have no liability in this regard. MCI shall furnish Bell Atlantic with all keys, entry codes, lock combinations, and other materials and information necessary for Bell Atlantic to gain entry to any secured MCI area. Bell Atlantic shall limit access to such areas to its authorized employees and agents.

1.6 Each Party shall promptly notify the other of any breach by the other Party of the foregoing provisions.

1.7 MCI shall ensure that MCI equipment at Bell Atlantic's premises is suitable for use in the operational environment at such premises. Bell Atlantic shall have no liability in this regard, other than to maintain the general environmental conditions in the premises at normal operational levels suitable for its own equipment.

Section 2. System Security

2.1 Each Party shall provide the other a back-up and recovery plan to be used in the event of a system failure or emergency to facilitate prompt systems restoration and recovery. The Parties shall reasonably cooperate to determine which systems require disaster, restoration and recovery plans. Any such plans will be provided to the other Party.

2.2 Each Party shall maintain a reasonable standard of security between operation system interfaces consistent with its own information security practices.

Section 3. Fraud Prevention

3.1 Each Party shall make available to the other fraud prevention features, including prevention, detection, or control functionality, that may be embedded within any of the Network Elements in accordance with applicable Tariffs or as otherwise mutually agreed, such as 900 NPA and international blocking offered to business customers and aggregators.

3.2 Uncollectible or unbillable revenues from fraud and resulting from, but not confined to provisioning, maintenance, or signal network routing errors shall be the responsibility of the Party causing such error.

3.3 Neither Party shall be responsible to the other for any fraud incurred in connection with their respective service offerings, except that each Party shall indemnify and hold each other harmless for any losses payable to IXC carriers caused by "clip-on" fraud incurred as a result of unauthorized access to an indemnifying party's Service Area Concept ("SAC"); provided that the indemnifying party shall control all negotiations and settlements of such claims with the applicable IXC carriers.

Section 4. Law Enforcement Interface

Each Party shall provide reasonable assistance to the other in accordance with Applicable Law and the Party's internal procedures in connection with: installation of and information retrieval from traps in its network, emergency traces on and information retrieval from subscriber invoked CLASS services (e.g., call traces requested by the other Party), and execution of wiretap or dialed number recorder orders from law enforcement authorities.

TABLE OF CONTENTS**Attachment X
PERFORMANCE REPORTING**

| | |
|--|-------|
| Section 1. Initial Performance Reporting | X - 1 |
| Section 2. Further Performance Reporting | X - 3 |
| Section 3. Definitions for Initial Performance Reports | X - 4 |
| Schedule A Service Category and Measurement Definitions | |
| Schedule B MCI _m Specific Measurement Report | |
| Schedule C Bell Atlantic Including Bell Atlantic Affiliates Measurement Report | |
| Schedule D Top 3 Carrier Customers Measurement Report | |
| Schedule E All CLECs Measurement Report | |
| Schedule F Top 10 Largest Customers Measurement Report | |
| Exhibit A Proposed Further Performance Reporting Measures | |

ATTACHMENT X

PERFORMANCE REPORTING

Section 1. Initial Performance Reporting

1.1 Bell Atlantic shall supply to MCI initial performance reports each month on Bell Atlantic's performance in Pennsylvania in accordance with this Section 1. The reports shall be substantially in the format of the documents attached hereto as Schedules B through F. The definitions of the rows and columns in the reports are set forth in Schedule A. The coverage of each report is set forth in its title, with the additional explanations set forth below.

1.1.1 Schedule B (MCI-Specific) will report the statewide performance of Bell Atlantic for the services provided to MCI for the preceding calendar month for the measures set forth in the report and defined in Schedule A. The dates in the cells in Schedule B are the dates that Bell Atlantic will be able to provide the information in that cell. Where the date is accompanied by the letters "Est." ("estimated"), the date in that cell is Bell Atlantic's best estimate and target, but not yet a commitment. Bell Atlantic will make its best efforts to meet the "Est." dates and will inform MCI of any potential change in those dates if and when that potential appears. Where the cell contains an "N/A" ("not applicable"), the measure is not applicable for that service category.

1.1.2 Schedule C (Bell Atlantic Including Bell Atlantic affiliates) will report statewide, system-wide performance of Bell Atlantic, including for the services provided to affiliate companies of Bell Atlantic, for the preceding calendar month for the measures set forth in the report and defined in Schedule A. The dates and notations in Schedule C have the same meanings as those described above for Schedule B. Bell Atlantic does not have an immediately comparable service for Unbundling and, as a result, those columns have been marked as "N/A". Bell Atlantic's "Retail - POTS" column reflects results from Bell Atlantic's retail operations for POTS services and is comparable to the "Resale - POTS" service on the other schedules (Schedule B, Schedule D, Schedule E and, when available, Schedule F).

1.1.3 Schedule D (Top 3 Carriers) will report the statewide performance of Bell Atlantic for the services provided to the largest three telecommunications carriers interconnecting with or purchasing services from Bell Atlantic pursuant to Sections 251 and 252 of the Act, combined, for the preceding calendar month for the measures set forth in the report and defined in Schedule A. The dates and

notations in Schedule D have the same meanings as those described above for Schedule B. In order to preserve the confidentiality of other carriers' information, results for a service (report column) will only be produced on this report if all three carriers purchased the reported service in the calendar month.

1.1.4 Schedule E (All CLECs) will report the statewide performance of Bell Atlantic for the services provided to telecommunications carriers interconnecting with or purchasing services from Bell Atlantic pursuant to Sections 251 and 252 of the Act and Bell Atlantic has a reporting obligation under the signed interconnection agreement, combined, for the preceding calendar month for the measures set forth in the report and defined in Schedule A. The dates and notations in Schedule E have the same meanings as those described above for Schedule B. In order to preserve the confidentiality of other carriers' information, results for a service (report column) will only be produced on this report if three carriers purchased the reported service in the calendar month.

1.1.5 Schedule F (10 Largest Retail Customers) will, at such time as Bell Atlantic is able to collect and report such information, and upon agreement regarding compensation for the collection and reporting of such information, if any, report statewide performance of Bell Atlantic for the services provided to its ten largest retail customers for the preceding calendar month for the measures set forth in the report and defined in Schedule A. The cells in Schedule F are all marked "TBD" ("to be determined") without an accompanying estimated date because Bell Atlantic has not yet determined that the collection and reporting of this information is feasible, and if it is, when such reporting might be available. Bell Atlantic agrees, however, that it will continue its best efforts assessment of the feasibility of collecting and reporting this information and will promptly report to MCI the results of that assessment and the availability of such information at such time as Bell Atlantic develops the capability to collect and report it for Bell Atlantic's own internal use.

1.2 The Parties agree that the performance information included in these reports is Confidential Information of Bell Atlantic and, with respect to MCI specific reports, Confidential Information of MCI under Section 22 of this Agreement. The Parties shall use such Confidential Information solely for internal performance assessment purposes, for purposes of joint MCI and Bell Atlantic assessments of service performance, and for reporting to the Commission, the FCC, or courts of competent jurisdiction, under cover of a protective order pursuant to Section 22 of Part A.

1.3 The question of what remedies or other action might be appropriate in any situation where MCI believes, based on a statistically significant number of data elements described above, that Bell Atlantic is not complying with any of the performance standards in the Agreement shall be resolved, in the first instance, through negotiations between the Parties to resolve the issue at the Director level of escalation, and, failing

prompt and successful negotiations, through the complaint processes of the Commission, the FCC, or a court of competent jurisdiction. Bell Atlantic agrees to join MCI in encouraging the Commission to develop expedited procedures for the resolution of any performance-related complaints.

Section 2. Further Performance Reporting

2.1 In addition to the performance reporting identified in Section 1, Bell Atlantic shall develop and provide to MCI further performance reporting in accordance with this Section 2.

2.1.1 Within thirty (30) days after the Effective Date of this Agreement, Bell Atlantic shall review MCI's list of reports (Exhibit A hereto) and identify those reports that Bell Atlantic either: (i) has already included in the reporting set forth in Section 1; (ii) produces for internal use; or (iii) is obligated to produce for regulatory purposes.

2.1.2 Within ninety (90) days after the Effective Date of this Agreement, Bell Atlantic shall provide MCI the estimated incremental costs of providing the reports included in Exhibit A hereto that are not identified pursuant to Paragraph 2.1.1. For reports for which the costs cannot be determined without the substantial participation of Bell Atlantic's equipment, software, or systems vendors, Bell Atlantic will identify such reports, and proceed to develop cost estimates with the vendor(s) only if authorized by MCI. If, after receiving cost estimates for particular reports, MCI elects to receive such reporting, MCI and other CLECs who also elect to receive such reports shall bear the incremental costs, allocated on a competitively-neutral basis, of providing any reports that Bell Atlantic does not provide for internal use or is not obligated to provide for regulatory purposes. The costs of developing cost estimates shall also be allocated among the receiving CLECs on a competitively-neutral basis.

2.1.3 Bell Atlantic shall begin reporting to MCI, and to other CLECs who also elect to receive such reports, all reports included in Exhibit A that MCI elects to receive in accordance with this Section 2.1.3 as soon as reasonably practicable after receiving MCI's written election and commitment to pay the costs of such reporting. Such reporting shall be integrated into the reporting set forth in Section 1.

2.1.4 MCI may from time to time request reports from Bell Atlantic that are not contained in MCI's original list (Exhibit A hereto). Bona Fide Request procedures set forth in Section 25 of Part A shall apply.

2.1.5 The Parties acknowledge that further discussions will be necessary to define the data upon which the reports are based. Therefore, within sixty (60) days after

the Effective Date of this Agreement, the Parties shall agree to such definitions and will amend this Attachment accordingly.

Section 3. Definitions for Initial Performance Reports

3.1 The following definitions apply to the Initial Performance Reports included in Section 1 above. Bell Atlantic shall develop and supply definitions at a comparable level of detail for any further performance reporting deployed pursuant to Section 2.

SCHEDULE A

SCHEDULE A

SERVICE CATEGORY (COLUMN) DEFINITIONS

| Name | Definition |
|--|--|
| Performance Measurement | Provides a general description of the fourteen (14) performance measurements. See Measurement Definitions - Rows below. |
| Special Services (Access) <i>DS0</i> <i>DS1</i> <i>DS3</i> | The column group title Special Services (Access) refers to Private Line Special Access results (does not include resold or unbundled services). DS1 and DS3 are discrete services. DS0 includes all other special services. |
| CLEC Trunking | The column represents service for CLEC trunks that carry traffic office to office. |
| Unbundling <i>POTS</i> <i>Special Services</i> | The column group title Unbundling refers to both POTS and Special unbundling services purchased by the CLEC. The POTS column includes the unbundled loops and ports. The Special Services column includes all special services combined. |
| Resale - POTS | The Resale-POTS column refers to POTS services that have been resold to the CLEC. On the Bell Atlantic Including Affiliates Report, the Retail-POTS column is comparable to the Resale-POTS column of the other four (4) reports. |

MEASUREMENT DEFINITIONS - ROW

| Name | Definition |
|-----------------------------|--|
| 1. Number of Installations | <p>This is the total number of service orders issued/requested by MCI_m and completed by Bell Atlantic. Regardless of the number of elements or circuits ordered, each service order counts as one.</p> <p>Number of Installations results can not be compared from report (e.g., MCI_m-Specific) to report (e.g., Bell Atlantic Including Bell Atlantic Affiliates). However, volume is a good indicator as to whether meaningful comparisons can be made about provisioning intervals and percent orders completed on time.</p> |
| 2. Average Interval in Days | <p>This is the sum of the receipt date to the service order due date as established on the firm order confirmation (FOC) for each service order where Bell Atlantic established the interval using the normal interval with this sum being divided by the total number of service orders used in the calculation</p> <p>MCI_m will send Bell Atlantic a service order request (PON) and Bell Atlantic will return the FOC which stipulates the scheduled completion date. The time from the PON date to the date due established on the FOC represents the average interval per order.</p> <p>Bell Atlantic flags each order with an appointment flag of either "x" or "w". If the scheduled interval reflected on the order is established by Bell Atlantic using the normal interval process, the order will be flagged with the "w". However, if MCI_m should request a date that is further out than the normal interval, the order will be flagged with the "x" to indicate that long interval was offered at the customer's request.</p> <p>For this category measurement, only those orders with the "w" indicator will be counted.</p> <p>If for some reason the order needs to be redated (longer or shorter), the final FOC date is the date that will be used for measurement purposes.</p> |
| 3. Percent Install on Time | This measurement is the total number of installations (both "x" and "w" service orders) that were completed on time (based on the service order established due date) divided by the total number of service orders. This is the percentage of orders completed on time. |

| Name | Definition |
|---|--|
| 4. Total Number of Missed Appointments | This measurement is the total number of service orders <i>not</i> completed on time. An appointment is defined as the date due agreed to by the customer and Bell Atlantic and shown on the order. If the customer issues a supplemental order changing the date due, the new date due will be measured as the appointment. Orders that are held or missed due to customer reasons <i>will not</i> be counted as a Bell Atlantic miss. This definition includes multi-item orders. If one item of a multi-item order is missed due to customer reasons, the order <i>will not</i> be counted as a Bell Atlantic miss. |
| 5. Total Percent of Missed Appointments | Total Number of Missed Appointments divided by the total number of service orders See appointment definition on item # 4. |
| 6. Number of Reports | This is the total number of customer trouble reports (i.e., CR troubles) received from MCI/m by service category. Each trouble counts as one and in cases where the trouble is redated or subsequent reports are received for escalations or to question status, Bell Atlantic will not count the subsequent reports. From receipt to close, each trouble counts as 1, regardless of the trouble resolution (CPE, NTF or Bell Atlantic Network). This measurement <i>does not include</i> information tickets (i.e., INF troubles). |
| 7. Mean Time to Clear Reports | <p>This is the total measurable hours and minutes from all customer trouble reports, i.e., #6 above, (from the time Bell Atlantic receives a trouble from MCI/m until the service is restored and closed with MCI/m) divided by the total number of troubles for the report period. This measurement <i>does not include</i> information tickets (i.e., INF troubles).</p> <p>For Special Services columns and CLEC Trunking, the measurements will be "Stop Clock" measurements where "no access" (customer access delayed) time is removed from the measurement.</p> <p>For POTS columns, this will be a running 24 hour clock from trouble receipt to trouble clearance time. The Bell Atlantic clear time is the time service is restored. The Bell Atlantic work process is for the customer (MCI/m) to be notified as soon as service is cleared. Bell Atlantic does not use the "close time" because after clearing the trouble, the technician may stay and complete another hour or so of clean up before actually closing the trouble.</p> |
| 8. Number of Failures | <p>The number of failures is the total number of trouble reports where the trouble was closed out with a code indicating that the fault was a Bell Atlantic service problem.</p> <p>Removed from the total trouble reports will be all the troubles that reflect the cause of the trouble to be other than a Bell Atlantic Network fault. Examples would be troubles caused by Customer Provided Equipment (CPE), errors by the customer's end user in the use of the service or where no trouble was detected (F OK and T OK).</p> |
| 9. Failure Frequency Percent | The Number of Failures (#8 above) divided by the total number of circuits that MCI/m has purchased from Bell Atlantic. The result expressed as a percentage. |
| 10. Percent Without Report Outstanding | <p>For this measurement, Bell Atlantic is to do the following:</p> <ol style="list-style-type: none"> 1. Multiply the total number of circuits by the total hours in the report period to establish the total hours of service availability possible for the report period. 2. Add all of the measurable time (hours and minutes) for only the network reports (i.e., Failures) to establish the total non service availability hours for the report period. 3. Subtract the "non service availability" hours from the "total service availability" hours and divide the result by the "total service availability" hours and display this as a percentage. |

| Name | Definition |
|--|---|
| 11. Total Number of Repeat Reports (30 days rolling) | This is the number of measured customer repeat reports (i.e., CR repeat reports) within a 30 day rolling window. The measured CR reports include: Car Clear (CC), Central Office (CO), Facility (FAC), Test OK (TOK), Serving Bureau Time (SVB), NPC - Bell Atlantic switch and beyond. Non-measured customer reports are Information (INF), Customer Provided Equipment (CPE), and Interexchange Carrier (IEC). This measurement will be provided initially at a regional level, not state specific. The 3 components of the regional measurement are: one for Pennsylvania and Delaware, one for New Jersey and one for the 4 former C&P Companies, Maryland, Virginia, West Virginia and Washington, DC. Bell Atlantic will request an enhancement to the support system being used for measurements. State specific measurements will be available on a date to be determined (TBD). |
| 12. Repeats as a Percent of Total Troubles | Number of measured customer repeat reports (i.e., CR repeat reports) divided by the total number of customer reports (i.e., CR reports). See definition of customer report contained in item # 11. This measurement will also be provided initially at a regional level, not state specific. See definition of regions in item # 11. |
| 13. Number of Out of Service Cleared >= 24 Hours | Number of out of service customer reports (i.e., CR reports) cleared in 24 hours or more. See definition of customer report contained in item # 11. For Special Services columns, the measurements will be "Stop Clock" measurements where "no access" time is removed from the measurement. |
| 14. Percent of Out of Service Cleared >= 24 Hours | Number of Out of Service Cleared >= 24 Hours divided by the total number of customer reports (i.e., CR reports). The result is expressed as a percentage. See definition of customer report contained in item # 11. For Special Services columns, the measurements will be "Stop Clock" measurements where "no access" time is removed from the measurement. |

SCHEDULE B

MCI Measurement Reports (Monthly Results Reported By State)

"MCI Specific" Report

| Performance Measurement | Special Services (Access) | | | CLEC Trunking | Unbundling | | Resale |
|---|---------------------------|-------------------|-------------------|------------------|-------------------|---------------------|-------------------|
| | DS0 | DS1 | DS3 | | POTS | Special Services | POTS |
| Installation | | | | | | | |
| 1 Number of Installations | See note below | See note below | See note below | 4/1/97 | Est. (7/1/97) | Est. (7/1/97) | Est. (7/1/97) |
| 2 Average Interval in Days | See note below | See note below | See note below | 4/1/97 | Est. (7/1/97) | Est. (7/1/97) | Est. (7/1/97) |
| 3 Percent Install on Time | See note below | See note below | See note below | 4/1/97 | Est. (7/1/97) | Est. (7/1/97) | Est. (7/1/97) |
| 4 Total Number of Missed Appointments | See note below | See note below | See note below | N/A | Est. (7/1/97) | Est. (7/1/97) | Est. (7/1/97) |
| 5 Total Percent of Missed Appointments | See note below | See note below | See note below | N/A | Est. (7/1/97) | Est. (7/1/97) | Est. (7/1/97) |
| Service Quality | | | | | | | |
| 6 Number of Reports | See note below | See note below | See note below | 4/1/97 | See note below | See note below | See note below |
| 7 Mean Time to Clear Reports | See note below | See note below | See note below | 4/1/97 | See note below | See note below | See note below |
| 8 Number of Failures | See note below | See note below | See note below | 4/1/97 | See note below | See note below | See note below |
| 9 Failure Frequency Percent | See note below | See note below | See note below | 4/1/97 | Est. (7/1/97) | Est. (7/1/97) | Est. (7/1/97) |
| 10 Percent Without Report Outstanding | See note below | See note below | See note below | 4/1/97 | Est. (7/1/97) | Est. (7/1/97) | Est. (7/1/97) |
| 11 Total Number of Repeat Reports (30 Days Rolling) | 4/1/97 | 4/1/97 | 4/1/97 | N/A | 4/1/97 | 4/1/97 | 4/1/97 |
| 12 Repeats as a Percent of Total Troubles | 4/1/97 | 4/1/97 | 4/1/97 | N/A | 4/1/97 | 4/1/97 | 4/1/97 |
| 13 Number of Out of Service Cleared >= 24 Hours | 4/1/97 | 4/1/97 | 4/1/97 | N/A | 4/1/97 | 4/1/97 | 4/1/97 |
| 14 Percent of Out of Service Cleared >= 24 Hours | 4/1/97 | 4/1/97 | 4/1/97 | N/A | 4/1/97 | 4/1/97 | 4/1/97 |

Note: End of first full calendar month following initial exchange of traffic between the Parties under this Agreement

SCHEDULE C

MCI Measurement Reports (Monthly Results Reported By State)

Bell Atlantic Including Bell Atlantic Affiliates Report

| Performance Measurement | Special Services (Access) | | | CLEC Trunking | Unbundling | | Retail |
|---|---------------------------|--------|--------|------------------|------------|---------------------|--------|
| | DS0 | DS1 | DS3 | | POTS | Special Services | POTS |
| Installation | | | | | | | |
| 1 Number of Installations | 1/1/97 | 1/1/97 | 1/1/97 | 4/1/97 | N/A | N/A | 1/1/97 |
| 2 Average Interval in Days | 1/1/97 | 1/1/97 | 1/1/97 | 4/1/97 | N/A | N/A | 1/1/97 |
| 3 Percent Install on Time | 1/1/97 | 1/1/97 | 1/1/97 | 4/1/97 | N/A | N/A | 1/1/97 |
| 4 Total Number of Missed Appointments | 1/1/97 | 1/1/97 | 1/1/97 | N/A | N/A | N/A | 1/1/97 |
| 5 Total Percent of Missed Appointments | 1/1/97 | 1/1/97 | 1/1/97 | N/A | N/A | N/A | 1/1/97 |
| Service Quality | | | | | | | |
| 6 Number of Reports | 1/1/97 | 1/1/97 | 1/1/97 | 4/1/97 | N/A | N/A | 1/1/97 |
| 7 Mean Time to Clear Reports | 1/1/97 | 1/1/97 | 1/1/97 | 4/1/97 | N/A | N/A | 1/1/97 |
| 8 Number of Failures | 1/1/97 | 1/1/97 | 1/1/97 | 4/1/97 | N/A | N/A | 1/1/97 |
| 9 Failure Frequency Percent | 1/1/97 | 1/1/97 | 1/1/97 | 4/1/97 | N/A | N/A | 1/1/97 |
| 10 Percent Without Report Outstanding | 1/1/97 | 1/1/97 | 1/1/97 | 4/1/97 | N/A | N/A | 1/1/97 |
| 11 Total Number of Repeat Reports (30 Days Rolling) | 4/1/97 | 4/1/97 | 4/1/97 | N/A | N/A | N/A | 4/1/97 |
| 12 Repeats as a Percent of Total Troubles | 4/1/97 | 4/1/97 | 4/1/97 | N/A | N/A | N/A | 4/1/97 |
| 13 Number of Out of Service Cleared >= 24 Hours | 4/1/97 | 4/1/97 | 4/1/97 | N/A | N/A | N/A | 4/1/97 |
| 14 Percent of Out of Service Cleared >= 24 Hours | 4/1/97 | 4/1/97 | 4/1/97 | N/A | N/A | N/A | 4/1/97 |

SCHEDULE D

Top 3 Carrier Customers Report

| Performance Measurement | Special Services (Access) | | | CLEC Trunking | Unbundling | | Resale |
|---|---------------------------|--------|--------|---------------|------------------|------------------|------------------|
| | DS0 | DS1 | DS3 | | POTS | Special Services | POTS |
| Installation | | | | | | | |
| 1 Number of Installations | 1/1/97 | 1/1/97 | 1/1/97 | 4/1/97 | Est. (7/1/97) | Est. (7/1/97) | Est. (7/1/97) |
| 2 Average Interval in Days | 1/1/97 | 1/1/97 | 1/1/97 | 4/1/97 | Est. (7/1/97) | Est. (7/1/97) | Est. (7/1/97) |
| 3 Percent Install on Time | 1/1/97 | 1/1/97 | 1/1/97 | 4/1/97 | Est. (7/1/97) | Est. (7/1/97) | Est. (7/1/97) |
| 4 Total Number of Missed Appointments | 1/1/97 | 1/1/97 | 1/1/97 | N/A | Est. (7/1/97) | Est. (7/1/97) | Est. (7/1/97) |
| 5 Total Percent of Missed Appointments | 1/1/97 | 1/1/97 | 1/1/97 | N/A | Est. (7/1/97) | Est. (7/1/97) | Est. (7/1/97) |
| Service Quality | | | | | | | |
| 6 Number of Reports | 1/1/97 | 1/1/97 | 1/1/97 | 4/1/97 | 1/1/97 | 1/1/97 | 1/1/97 |
| 7 Mean Time to Clear Reports | 1/1/97 | 1/1/97 | 1/1/97 | 4/1/97 | 1/1/97 | 1/1/97 | 1/1/97 |
| 8 Number of Failures | 1/1/97 | 1/1/97 | 1/1/97 | 4/1/97 | 1/1/97 | 1/1/97 | 1/1/97 |
| 9 Failure Frequency Percent | 1/1/97 | 1/1/97 | 1/1/97 | 4/1/97 | Est. (7/1/97) | Est. (7/1/97) | Est. (7/1/97) |
| 10 Percent Without Report Outstanding | 1/1/97 | 1/1/97 | 1/1/97 | 4/1/97 | Est. (7/1/97) | Est. (7/1/97) | Est. (7/1/97) |
| 11 Total Number of Repeat Reports (30 Days Rolling) | 4/1/97 | 4/1/97 | 4/1/97 | N/A | 4/1/97 | 4/1/97 | 4/1/97 |
| 12 Repeats as a Percent of Total Troubles | 4/1/97 | 4/1/97 | 4/1/97 | N/A | 4/1/97 | 4/1/97 | 4/1/97 |
| 13 Number of Out of Service Cleared >= 24 Hours | 4/1/97 | 4/1/97 | 4/1/97 | N/A | 4/1/97 | 4/1/97 | 4/1/97 |
| 14 Percent of Out of Service Cleared >= 24 Hours | 4/1/97 | 4/1/97 | 4/1/97 | N/A | 4/1/97 | 4/1/97 | 4/1/97 |

Note: Results produced when a minimum of 3 carriers purchase measured service.

SCHEDULE E

All CLECs Report

| Performance Measurement | Special Services (Access) | | | CLEC Trunking | Unbundling | | Resale |
|---|---------------------------|--------|--------|---------------|------------------|------------------|------------------|
| | DS0 | DS1 | DS3 | | POTS | Special Services | POTS |
| Installation | | | | | | | |
| 1 Number of Installations | 1/1/97 | 1/1/97 | 1/1/97 | 4/1/97 | Est. (7/1/97) | Est. (7/1/97) | Est. (7/1/97) |
| 2 Average Interval in Days | 1/1/97 | 1/1/97 | 1/1/97 | 4/1/97 | Est. (7/1/97) | Est. (7/1/97) | Est. (7/1/97) |
| 3 Percent Install on Time | 1/1/97 | 1/1/97 | 1/1/97 | 4/1/97 | Est. (7/1/97) | Est. (7/1/97) | Est. (7/1/97) |
| 4 Total Number of Missed Appointments | 1/1/97 | 1/1/97 | 1/1/97 | N/A | Est. (7/1/97) | Est. (7/1/97) | Est. (7/1/97) |
| 5 Total Percent of Missed Appointments | 1/1/97 | 1/1/97 | 1/1/97 | N/A | Est. (7/1/97) | Est. (7/1/97) | Est. (7/1/97) |
| Service Quality | | | | | | | |
| 6 Number of Reports | 1/1/97 | 1/1/97 | 1/1/97 | 4/1/97 | 1/1/97 | 1/1/97 | 1/1/97 |
| 7 Mean Time to Clear Reports | 1/1/97 | 1/1/97 | 1/1/97 | 4/1/97 | 1/1/97 | 1/1/97 | 1/1/97 |
| 8 Number of Failures | 1/1/97 | 1/1/97 | 1/1/97 | 4/1/97 | 1/1/97 | 1/1/97 | 1/1/97 |
| 9 Failure Frequency Percent | 1/1/97 | 1/1/97 | 1/1/97 | 4/1/97 | Est. (7/1/97) | Est. (7/1/97) | Est. (7/1/97) |
| 10 Percent Without Report Outstanding | 1/1/97 | 1/1/97 | 1/1/97 | 4/1/97 | Est. (7/1/97) | Est. (7/1/97) | Est. (7/1/97) |
| 11 Total Number of Repeat Reports (30 Days Rolling) | 4/1/97 | 4/1/97 | 4/1/97 | N/A | 4/1/97 | 4/1/97 | 4/1/97 |
| 12 Repeats as a Percent of Total Troubles | 4/1/97 | 4/1/97 | 4/1/97 | N/A | 4/1/97 | 4/1/97 | 4/1/97 |
| 13 Number of Out of Service Cleared >= 24 Hours | 4/1/97 | 4/1/97 | 4/1/97 | N/A | 4/1/97 | 4/1/97 | 4/1/97 |
| 14 Percent of Out of Service Cleared >= 24 Hours | 4/1/97 | 4/1/97 | 4/1/97 | N/A | 4/1/97 | 4/1/97 | 4/1/97 |

Note: Results produced when a minimum of 3 carriers purchase measured service

SCHEDULE F

Top 10 Largest Customers Report

| Performance Measurement | Special Services (Access) | | | CLEC Trunking | Unbundling | | Resale |
|---|---------------------------|-----|-----|---------------|------------|------------------|--------|
| | DS0 | DS1 | DS3 | | POTS | Special Services | POTS |
| Installation | | | | | | | |
| 1 Number of Installations | TBD | TBD | TBD | TBD | TBD | TBD | TBD |
| 2 Average Interval in Days | TBD | TBD | TBD | TBD | TBD | TBD | TBD |
| 3 Percent Install on Time | TBD | TBD | TBD | TBD | TBD | TBD | TBD |
| 4 Total Number of Missed Appointments | TBD | TBD | TBD | TBD | TBD | TBD | TBD |
| 5 Total Percent of Missed Appointments | TBD | TBD | TBD | TBD | TBD | TBD | TBD |
| Service Quality | | | | | | | |
| 6 Number of Reports | TBD | TBD | TBD | TBD | TBD | TBD | TBD |
| 7 Mean Time to Clear Reports | TBD | TBD | TBD | TBD | TBD | TBD | TBD |
| 8 Number of Failures | TBD | TBD | TBD | TBD | TBD | TBD | TBD |
| 9 Failure Frequency Percent | TBD | TBD | TBD | TBD | TBD | TBD | TBD |
| 10 Percent Without Report Outstanding | TBD | TBD | TBD | TBD | TBD | TBD | TBD |
| 11 Total Number of Repeat Reports (30 Days Rolling) | TBD | TBD | TBD | TBD | TBD | TBD | TBD |
| 12 Repeats as a Percent of Total Troubles | TBD | TBD | TBD | TBD | TBD | TBD | TBD |
| 13 Number of Out of Service Cleared >= 24 Hours | TBD | TBD | TBD | TBD | TBD | TBD | TBD |
| 14 Percent of Out of Service Cleared >= 24 Hours | TBD | TBD | TBD | TBD | TBD | TBD | TBD |

EXHIBIT A

Exhibit A

| Proposed Further Performance Reporting Measures |
|--|
| Ordering and Provisioning |
| Time to provision each unbundled element |
| Time to install resold lines and trunks - varies according to line size, line type, and need for premises visit. |
| Total number and percent of missed appointments |
| Total number and % of missed firm order commitment dates |
| Time to acknowledge receipt of service order |
| Time to provide FOC or notification of a rejected order |
| Time to complete any suspend/block/restore/order |
| Time to install Centrex lines |
| Time to implement feature change |
| Time to disconnect resold service - varies with or without premises visit |
| Time to disconnect resale service |
| Time to disconnect unbundled switching service |
| Time to disconnect other unbundled service - |
| % of Outages within 30 days for new services provisioned |
| |
| Usage Billing |
| Time taken to send records to MCI following recording |
| Number of omissions from records |
| |
| Maintenance and Repair |
| In service and out of service repair intervals |
| Number and percentage of Repeat Troubles |
| Troubles per 100 lines |
| Time taken to answer phone where manual service provided |
| Number and percentage of missed appointments |
| Number and percentage of estimated time to restore met. |
| Number and percentage of troubles requiring a dispatch |
| % breakdowns attributed to each trouble category |
| |

| |
|---|
| Proposed Further Performance Reporting Measures |
| |
| Operational Systems |
| Support Systems Availability |
| System Response Time |
| |
| Operator Services |
| Monthly Average for Seconds of Operator Answer Delay |
| Monthly Total of Quarter Hours of Operator Answer Delay |
| Monthly Call Abandonment and Blockage |
| |
| Directory Assistance |
| Voice DA Availability |
| Voice DA Outage Restoral Notification |
| Voice DA Time to Answer |
| Voice DA Average Work Time |
| Voice DA Abandonment From Queue |
| |
| Network Performance |
| Switched Service Disruption |
| Dedicated Service Disruption |
| Network Event |
| Blocked Calls |
| Blocked Dial Tone |
| Post Dial Delay |
| |

DIRECTORY ASSISTANCE LICENSE AGREEMENT

This Agreement is entered into this _____ 19th _____ day of November, 1998 between Bell Atlantic Network Services, Inc., on behalf of itself and its operating telephone company affiliates¹, (hereinafter referred to collectively as the "Telephone Company") and MCI Telecommunications Corporation, on behalf of itself and its wholly-owned subsidiaries MCImetro Access Transmission Services, Inc., and MCImetro Access Transmission Services of Virginia, Inc. (hereinafter referred to as the "Licensee").

WHEREAS, Licensee and Telephone Company have been engaged in a dispute in several jurisdictions over the manner in which the Telephone Company should provide directory assistance data to Licensee, and other related terms, and

WHEREAS both parties seek to resolve their differences over this issue through negotiation and have executed a Settlement Agreement concurrent with the execution of this Agreement; and

WHEREAS Licensee desires to procure directory assistance data for purposes permitted under this negotiated Agreement including all of the terms and conditions set forth in this Agreement, and

¹ Bell Atlantic-Delaware, Inc.; Bell Atlantic-Maryland, Inc.; Bell Atlantic-New Jersey, Inc.; Bell Atlantic-Pennsylvania, Inc.; Bell Atlantic-Virginia, Inc.; Bell Atlantic-Washington, D.C., Inc.; Bell Atlantic-West Virginia, Inc.; New York Telephone Company (providing service in New York and Connecticut) and New England Telephone and Telegraph Company and any assigns or successors of these companies.

WHEREAS, the Telephone Company is willing to furnish Licensee subscriber listings from its directory assistance databases, pursuant to this negotiated Agreement including all of the terms and conditions set forth in this Agreement.

NOW, THEREFORE, it is agreed by and between the parties as follows:

1. **Term** - The term of this Agreement shall be for three (3) years commencing on December 1, 1998 and ending on November 30, 2001. This Agreement shall be extended automatically for subsequent terms of one (1) year unless either the Licensee or the Telephone Company provides written notice of its intent not to renew the Agreement at least one hundred and eighty (180) days before the expiration of the current term. In the event either party elects not to renew this Agreement, Licensee and the Telephone Company will in good faith negotiate an agreement to succeed this Agreement, and during such negotiations this Agreement will remain in full force and effect until the earlier of: (i) execution of a succeeding agreement by Licensee and the Telephone Company or (ii) two (2) years after the date on which this Agreement would have expired.
2. **Provision of Directory Assistance Data** - Telephone Company shall provide to Licensee Directory Assistance Data through an electronic transfer as specified in Exhibit B. Directory Assistance Data shall mean the names, addresses, listing types, telephone numbers, and (if applicable) the non-published listing indicator, of all residential, business, and government subscribers in the Telephone Company's thirteen operating states and the District of Columbia and contained in the databases created and maintained by the Telephone Company for the provision of directory

assistance type services, but excludes the line number for non-published listings (hereinafter "Directory Assistance Data"). Directory Assistance Data also includes the same data relating to local exchange carrier ("LEC") subscribers and independent telephone company ("ITC") subscribers, to the extent that the Telephone Company is not precluded from releasing such data. In the event a LEC or ITC denies the Telephone Company the authorization to release LEC or ITC data and in negotiations with LECs and ITCs for use of their data, Telephone Company will use its best efforts to seek in good faith the authorization to release Directory Assistance Data from each LEC and ITC whose subscribers listings are included in the Directory Assistance Data created and maintained by the Telephone Company. It is acknowledged that any breach of the obligations of this paragraph will constitute a material breach of this Agreement.

3. **Technical Specifications** - Telephone Company shall provide Directory Assistance Data, including the initial extract and daily updates, to Licensee in accordance with and as specified in the technical specifications contained and incorporated herein as Exhibit B. To assure the continuity and content of the Directory Assistance Data provided to Licensee, Telephone Company shall not revise, change or modify these technical specifications unless agreed to by Licensee or unless Telephone Company has provided Licensee six (6) months advance written notice of such revisions. It is acknowledged that any breach of the obligations of this paragraph will constitute a material breach of this Agreement.

4. **Initial Extract** - Beginning no later than thirty (30) days after the execution of this Agreement and in compliance with a mutually agreeable schedule, Telephone Company shall provide initial extracts of Directory Assistance Data for all listings as set forth in Paragraph 3 via electronic data transfer. Any initial extract for Directory Assistance Data (along with update files previously provided by the Telephone Company prior to the execution of this Agreement) will be covered by this Agreement. Each initial extract, along with any necessary update files, will reflect all Directory Assistance Data that is in the Telephone Company's Directory Assistance Database as of one (1) business day prior to the provision date. It is acknowledged that any breach of the obligations of this paragraph will constitute a material breach of this Agreement.

5. **Daily Updates** - Subsequent to the provision of each initial extract, Telephone Company shall provide Licensee with daily updates to the Directory Assistance Data via electronic data transfer. Daily updates will reflect all listing change activity occurring since the previous update. The updates shall be used solely by the Licensee to provide the services authorized by this Agreement. Telephone Company shall correct errors in its previously transmitted Directory Assistance Data via daily updates in the same manner that Telephone Company corrects errors included in its database. Upon Licensee's request, Telephone Company shall provide a refresh of the Directory Assistance Data within thirty (30) days after Licensee's request and in accordance with the same terms and conditions that apply to an initial extract of Directory Assistance Data, so long as the fulfillment of the request would not

interfere with Telephone Company's normal administration and maintenance operations. If fulfillment of the request does interfere with Telephone Company's normal administration and maintenance operations, Telephone Company will begin to provide Licensee with the requested refresh within thirty (30) days after the request and continue providing additional necessary extracts in accordance with a mutually agreeable schedule. It is acknowledged that any breach of the obligations of this paragraph will constitute a material breach of this Agreement.

6. **Grant of License** - The Telephone Company grants to the Licensee, during the terms of this Agreement, a non-exclusive license to use the Directory Assistance Data supplied by the Telephone Company hereunder. Licensee shall use Directory Assistance Data solely for the purposes of providing directory assistance-type services and shall not use Directory Assistance Data for telemarketing, sales, marketing, directory compilation, publishing, or for any advertiser supported service. Licensee shall use nonpublished Directory Assistance Data for the sole purpose of indicating that such subscriber listing is nonpublished. Licensee shall have no right to resell, transfer, or sub-license Directory Assistance Data in bulk under this Agreement without the written consent of the Telephone Company. It is acknowledged that any breach of the obligations of this paragraph will constitute a material breach of this Agreement.

7. **Payment** - Licensee shall pay the Telephone Company in accordance with charges listed in Exhibit A, which is incorporated herein. Bills shall include any local, state or federal taxes and delivery charges which may apply. Payment shall be made by

Licensee within thirty (30) days after receipt of the invoice. The Telephone Company will use its best efforts to develop and implement electronic billing for the Directory Assistance Data provided hereunder. The Telephone Company reserves the right to impose late charges not to exceed 1½% per month, or the lawful rate of interest, whichever is lower, on bills outstanding more than thirty (30) days. If a billing dispute arises concerning any charges billed pursuant to this Agreement, Licensee may elect to: (i) withhold payment of those charges in dispute, subject to its payment of interest on any amount Licensee owes upon resolution of the dispute; or (ii) pay the billed amount in whole, subject to Telephone Company's payment of interest on any amount by which it is determined that Licensee over paid. The applicable interest rate regarding the foregoing sentence for both the Telephone Company and Licensee will not exceed 1½% per month, or the lawful rate of interest, whichever is lower. It is acknowledged that any breach of the obligations of this paragraph will constitute a material breach of this Agreement.

8. **Non-Exclusivity** - Nothing in this Agreement or elsewhere shall give the Licensee any exclusive right to the Telephone Company's Directory Assistance Data, and the Telephone Company shall be free at any time to grant similar licenses to others as the Telephone Company, in its sole discretion, may determine.
9. **Most Favored Customer** - In the event Telephone Company makes available or provides Directory Assistance Data for the Telephone Company's entire operating region to any entity or entities for directory assistance type uses, by agreement, tariff, or other arrangement, either individually or in combination, the Telephone Company

will present Licensee with a copy of the relevant portions of the agreement(s), tariff(s), or other arrangement(s) (except for agreements filed with a regulatory agency pursuant to Section 252 of the Telecommunications Act of 1996 and tariffs filed with a regulatory agency) within thirty (30) days after their effectiveness and permit the Licensee an opportunity to inspect such portions of the agreement, tariff, or other arrangement. Licensee agrees that any information provided pursuant to this paragraph is confidential, and to use such information solely for the purposes of determining whether Licensee has a right under this License Agreement to substitute agreements. Licensee further agrees to limit review of such information to counsel and to one designated Licensee representative who shall be identified to Bell Atlantic, unless Licensee believes in good faith that it intends to exercise its rights under this paragraph. No more than three (3) times in any calendar year, Licensee may hire, at its expense, an independent auditor that is agreeable to Telephone Company (such agreement not to be unreasonably withheld). The Telephone Company will present the auditor with a copy of the relevant portions of any agreement(s), tariff(s), or other arrangement(s) that may exist and permit the auditor an opportunity to inspect such portions of the agreement(s), tariff(s), or other arrangement(s); provided the auditor agrees to keep such information confidential and to use such information solely for the purposes of determining whether the Telephone Company has made available or provided Directory Assistance Data (either individually or in combination) for the Telephone Company's entire operating region. In the event any agreement(s), tariff(s), or other arrangement(s), (either individually or in combination) offer Directory Assistance Data for the Telephone Company's entire operating region at

more favorable, rates, terms or conditions than this Agreement, Licensee may, by so notifying the Telephone Company in writing within sixty (60) days after it or its auditor receives notice that such agreement(s), tariff(s) or other arrangement(s) first covered the Telephone Company's entire operating region, substitute in their entirety all of the prices, terms and conditions regarding the Telephone Company's provision of Directory Assistance Data and contained in the other agreement(s), tariff(s), or other arrangement(s) in place of all of the prices, terms and conditions in this Agreement in their entirety, with effect from the date such agreement(s), tariff(s), or other arrangement(s) first covered the Telephone Company's entire operating region, and for the remainder of the term of those agreement(s), tariff(s) or other arrangement(s). It is acknowledged that any breach of this paragraph will constitute a material breach of this Agreement.

10. **Developed Information** - Any programs or applications which are developed solely by Telephone Company or Licensee in connection with the provision and receipt of Directory Assistance Data shall be the exclusive property of the party developing such programs in the absence of any other agreement by and between the parties. The non-developing party shall have no rights nor title thereto whatsoever.

11. **Security of Directory Assistance Data** - Licensee shall not permit anyone but its duly authorized employees or agents to inspect or use in bulk the Directory Assistance Data or by-products of the data furnished by the Telephone Company. Licensee shall take appropriate security measures to guard against unauthorized use of the data or by-products of the data furnished hereunder by employees or others.

Licensee shall cooperate with the Telephone Company in investigating unauthorized disclosures of the Directory Assistance Data related to Licensee's use of the data. It is acknowledged that any breach of this paragraph will constitute a material breach of this Agreement. Nothing contained in this Agreement shall restrict, impair or in any way diminish any proprietary interest of the Telephone Company, if any exists, in the Directory Assistance Data supplied to the Licensee.

12. **Relationship of the Parties** - It is the intention of the parties that they be independent contractors. Nothing contained herein will constitute the parties as joint venturers, partners, employees or agents of one another, and neither party shall have the right or power to obligate the other. Neither Licensee nor its employees, agents or representatives shall represent in any way to any person that the Telephone Company has any responsibility for or in connection with Licensee's use of the Directory Assistance Data. However, to the extent Licensee becomes aware of an incorrect listing involving a subscriber of the Telephone Company, Licensee may advise that subscriber to contact the subscriber's business office of the Telephone Company to correct the listing. Licensee shall be solely responsible for interacting with the Telephone Company to resolve any questions it receives from Licensee's local exchange service customers relating to the accuracy or content of Telephone Company information. The Telephone Company will assist Licensee in correcting any errors or inaccuracies found in the Directory Assistance Data provided hereunder.

13. LIMITATION OF LIABILITY - BOTH PARTIES SHALL ARRANGE FOR TARIFFS LIMITING THEIR RESPECTIVE LIABILITY IN CONNECTION WITH THE PROVISION OF SERVICES ASSOCIATED WITH THIS AGREEMENT. NEITHER PARTY SHALL BE LIABLE TO THE OTHER FOR ANY INDIRECT, INCIDENTAL, SPECIAL OR CONSEQUENTIAL DAMAGES ARISING OUT OF OR RELATED TO THIS AGREEMENT; PROVIDED, HOWEVER, THAT,

(i) IN THE EVENT OF A PARTY'S WILLFUL OR INTENTIONAL MISCONDUCT, GROSS NEGLIGENCE, INTENTIONAL NON-PERFORMANCE, OR REPEAT NON-PERFORMANCE (MULTIPLE OCCURRENCES THAT ARE PART OF THE SAME TRANSACTION SHALL NOT CONSTITUTE REPEAT NON-PERFORMANCE), AND WHERE SUCH ACTIONS OR OMISSIONS HAVE NOT BEEN CURED PURSUANT TO THE CURE PROVISIONS SET FORTH IN PARAGRAPH 19, THE BREACHING PARTY SHALL BE LIABLE FOR THE ACTUAL DIRECT DAMAGES AND ANY AND ALL FORESEEABLE DAMAGES CAUSED BY SUCH ACTIONS OR OMISSIONS; AND

(ii) THE TELEPHONE COMPANY'S LIABILITY FOR ERRORS, DEVIATIONS, OR OMISSIONS IN THE DATA FURNISHED TO THE LICENSEE WILL BE LIMITED TO A CREDIT OR REFUND OF THE CHARGES PAID FOR THE DATA, TAPES, OR PARTS THEREOF, OMITTED OR IN ERROR.

14. **Warranty** - The Telephone Company disclaims all warranties, express or implied, concerning any data or materials (or their accuracy) including but not limited to warranties of merchantability or fitness for particular purposes. However, the Telephone Company does warrant that the Directory Assistance Data provided to Licensee pursuant to this Agreement will be identical in content to the Directory Assistance Data that is input by the Telephone Company into the databases used by Telephone Company to provide directory assistance type services to its end user customers. Telephone Company will provide, and warrants that it will provide, Licensee with access to any directory assistance data (not necessarily as defined in Paragraph 2 above) to the extent required subsequently (either through changes in the applicable law or through changes to the manner in which the Telephone Company provides directory assistance services) by the Telecommunications Act of 1996, the FCC's implementing regulations thereunder, or a state regulatory agency (with respect to that agency's geographic jurisdiction), or any judicial interpretations of these three, in the context of providing directory assistance data as an unbundled network element.

15. **Dispute Resolution** - Licensee and the Telephone Company agree that the individual state commissions will have jurisdiction to implement and enforce all terms and conditions of this Agreement. Accordingly, the Telephone Company and Licensee agree that any dispute arising out of or relating to this Agreement that the parties themselves cannot resolve may be submitted to the appropriate state commission for resolution and accepted subject to the discretion of that commission. The parties

agree to seek expedited resolution by the appropriate state commission, and shall request that resolution occur in no event later than sixty (60) days from the date of submission of such dispute. The parties agree that the state commission may direct them to engage an expert(s) or other facilitator(s) to assist in its decision making. Each party shall pay half of the fees and expenses so incurred. During the proceeding each party shall continue to perform its obligations under this Agreement; provided, however, that neither party shall be required to act in any unlawful fashion. This paragraph will not preclude the parties from seeking relief available in any other forum.

16. **Notice** - All notices or other communications under this Agreement will be deemed to have been duly given when made in writing and delivered either in person or deposited in the United States mail, certified mail, postage prepaid, return receipt requested and addressed as follows: The addresses above may be changed by written notice given by one party to the other pursuant to this paragraph.

To Licensee: MCImetro Access Transmission Services, Inc.
Attention: Vice President
7900 Westpark Drive, 8th Floor
McLean, VA 22102

Copies to: Vice President, ISN Service & Solutions
MCI WorldCom
601 South 12th Street, 12th Floor North
Arlington, VA 22202

General Counsel

MCI WorldCom
1801 Pennsylvania Ave., N.W.
Washington, DC 20006

To Telephone Company: Bell Atlantic Network Services, Inc
Attn: Vice President -Operator Services
13100 Columbia Pike
Silver Spring, MD 20904

Copy to: Legal Department
Bell Atlantic Network Services, Inc.
Attention: Counsel, Public & Operator Services
1320 North Courthouse Road, 8th Floor
Arlington, VA 22201

17. **Non-Waiver** - A failure or delay of either Party (including any course of dealing or course of performance) to enforce any of the provisions of this Agreement, or any right or remedy available under this Agreement or at law or in equity, or to require performance of any of the provisions of this Agreement, shall in no way be construed to be a waiver of such provisions, rights, remedies or options.

18. **Assignment** - Any assignment or delegation by either party to any non-affiliated entity of any right, obligation or duty, or of any interest hereunder, in whole or in part, without the prior written consent of the other party shall be void. A party assigning or delegating this Agreement or any right obligation, duty or other interest hereunder to an affiliate shall provide written notice to the other party. All obligations and duties of any party under this Agreement shall be binding on all

successors in interest and assigns of such party. No assignment or delegation shall relieve the assignor of its obligations under this Agreement.

19. **Breach** - If either party breaches any material provision of this Agreement, the non-breaching party may terminate this Agreement after providing the breaching party with written notice and thirty (30) days to cure such breach. If the breach has not been cured within thirty (30) days after receipt of written notice, this Agreement may be terminated by the non-breaching party. In the event of a breach of any material term of this Agreement, either party will have the right to enforce the Agreement by injunction and by such other equitable and legal proceedings as they may deem appropriate.
20. **Termination** - Upon expiration or termination, any Telephone Company data provided by the Telephone Company or copies or byproducts thereof, must be destroyed or returned by Licensee.
21. **Regulatory Compliance** - Each party shall be responsible for obtaining and keeping in effect all FCC, state regulatory, franchise authority and other regulatory approvals that may be required in connection with the performance of its obligations under this Agreement. This is a negotiated Agreement, and the parties agree to comply with the terms and conditions of the Settlement Agreement, which has been executed concurrently with this Agreement and which is incorporated herein. It is acknowledged that a breach of the Settlement Agreement will constitute a material breach of this Agreement.

22. **Publicity** - Licensee shall not publicize, advertise, or market to others any information relating to the terms of this contract without the Telephone Company's express written consent. However, Licensee may provide factual information to customers or prospects requesting such information that it obtains Directory Assistance Data from Bell Atlantic.
23. **Force Majeure** - Neither party shall be held responsible for any delay or failure in performance hereunder caused by fires, strikes, embargoes, requirements imposed by government regulation, civil or military authorities, acts of God, or by a public enemy or other similar cause beyond such party's control. In the event of any excused delay or failure to perform due to the events set forth in the foregoing sentence, the due date for the performance of the original obligation will only be extended for a term equal in length to the time lost by reason of the excusing event.
24. **Governing Law**. - This Agreement shall be governed by and interpreted according to the laws, without regard to its conflict of laws rules, of the Commonwealth of Virginia. Each party will comply with all applicable laws, regulations and rulings of any court or regulatory jurisdiction of competent jurisdiction.
25. **Specific Performance** - The obligations of the parties and the services offered under this Agreement are unique. Accordingly, in addition to any other available rights or remedies, either party may sue in equity for specific performance.

26. Integration Clause - This writing constitutes the entire Agreement between the parties and shall not be changed except by written agreement signed by both parties.

27. Counterparts - This Agreement may be executed in counterparts. Each counterpart shall be considered an original and such counterparts shall together constitute one and the same instrument.

IN WITNESS WHEREOF, the parties have caused this Agreement to be executed on the date first mentioned above.

LICENSEE

TELEPHONE COMPANY

By _____

By _____

Title _____

Title _____

Date _____

Date _____

Exhibit A to License Agreement

STANDARD CHARGES

I. Directory Assistance Data Fees

- A. Licensee shall pay Telephone Company a fee of \$.029 for each listing provided as part of either an initial extract of, part of a daily update, or as a refresh of previously provided Directory Assistance Data.
- B. All costs associated with establishing and maintaining data communication access to Telephone Company's data centers are the responsibility of the Licensee.
- C. No sooner than thirty (30) days after the execution of this Agreement, the Telephone Company shall bill, and Licensee shall pay in accordance with paragraph 7, the estimated amount for the initial extracts and previously provided Directory Assistance Data (all initial extracts previously provided and updates in New York and Virginia) covered by this Agreement. The parties agree that the initial extract and the previously provided Directory Assistance Data shall include approximately 40,000,000 listings, and said estimated payment shall be \$1,160,000. With respect to subsequent daily updates, Telephone Company will bill Licensee on a monthly basis for one-twelfth of the estimated annual billings for all listing updates covered by this Agreement. These estimated amounts paid by Licensee will be trued up retroactively by the Telephone Company and

Licensee on an annual basis to reflect payment for the number of listings actually received by Licensee.

- D. During the first twelve (12) months after the execution of this Agreement, Licensee agrees to purchase a minimum of 60,000,000 Directory Assistance Data listings (including the initial extracts, previously provided Directory Assistance Data and subsequent daily updates), and to pay a minimum fee of \$1,700,000. However, in the event that Licensee has requested the entire region as set forth above, and Telephone Company is not able to provide a minimum of 60,000,000 listings, the minimum fee paid by Licensee will be reduced (in the annual true-up described in Paragraph C above) to the actual number of listings provided. For each subsequent twelve (12) month period, Licensee agrees to purchase a minimum of 30,000,000 directory assistance listings for the term of this Agreement. However, in the event that the Telephone Company is not able to provide a minimum of 30,000,000 listings during any of the subsequent twelve (12) month periods, the minimum fee paid by Licensee will be reduced (in the annual true-up described in Paragraph C above) to the actual number of listings provided.

**Amendment Number One to the
Interconnection Agreement
between
Bell Atlantic-Pennsylvania, Inc.
and
MCImetro Access Transmission Services LLC**

THIS AMENDMENT NUMBER ONE to the Interconnection Agreement (the "Agreement") executed on July 8, 1997 between Bell Atlantic-Pennsylvania, Inc. ("Bell Atlantic"), a Pennsylvania corporation with offices at 1717 Arch Street, Philadelphia, Pennsylvania 19103 and MCImetro Access Transmission Services, Inc. ("MCI"), is entered into this 17 day of December 1998 by and between Bell Atlantic and MCImetro Access Transmission Services LLC, a Delaware corporation with offices at 8521 Leesburg Pike, Vienna, Virginia, 22182.

WHEREAS, MCImetro Access Transmission Services, Inc. has merged into MCImetro Access Transmission Services LLC effective December 1, 1998 at 5:01 p.m.; and

WHEREAS, by operation of law, as of the effective date of the merger, MCImetro Access Transmission Services LLC is responsible for all of the obligations and liabilities of MCImetro Access Transmission Services, Inc.; and

WHEREAS, pursuant to Section 41 of Part A of the Agreement, the Agreement is binding upon and inures to the benefit of MCImetro Access Transmission Services LLC as the successor to MCImetro Access Transmission Services, Inc.; and

WHEREAS, Bell Atlantic and MCImetro Access Transmission Services LLC (the "Parties") wish to amend the Agreement to reflect the appropriate corporate name; and

WHEREAS, Bell Atlantic and MCImetro Access Transmission Services, Inc. entered into a Directory Assistance License Agreement and a Settlement Agreement both dated November 19, 1998; and

WHEREAS, the Parties desire that the Agreement incorporate the rates, terms and conditions of the Directory Assistance License Agreement and the Settlement Agreement;

NOW, THEREFORE, pursuant to Section 35 of Part A of the Agreement, the Parties agree to amend the Agreement as set forth in the Parts A and B and Attachments I, III, VI and VIII attached hereto.

IN WITNESS WHEREOF, the undersigned have caused this Amendment Number One to be duly executed and become effective as of the date hereof.

MCIMETRO ACCESS
TRANSMISSION SERVICES LLC

By: *Marcel Henry*

Name: Marcel Henry

Title: Vice President

Date: 12/9/98

BELL ATLANTIC-PENNSYLVANIA,
Inc.

By: *Jeffrey A. Masoner*

Name: Jeffrey A. Masoner

Title: Vice President

Date: 12-17-98

LIST OF REVISED SECTIONS
MCI_m-BELL ATLANTIC-PENNSYLVANIA
INTERCONNECTION AGREEMENT

AMENDMENT NUMBER 1: Dated December 17, 1998

List of Affected Sections:

List of Current Versions

Part A, introductory paragraph

Part A, Section 14

Part B, definition of "MCI_m"

Attachment I, Table 1, Line Item 7.b.

Attachment III, Section 8

Attachment III, Section 17

Attachment VI, Appendix I (introductory paragraph)

Attachment VI, Appendix II (introductory paragraph)

Attachment VIII, Section 6.1.7

LIST OF CURRENT VERSIONS
MCI^m-BELL ATLANTIC-PENNSYLVANIA
INTERCONNECTION AGREEMENT
(BY ATTACHMENT)

| <u>ATTACHMENT</u> | <u>VERSION</u> |
|-------------------|---|
| PART A | Last Revised 12/17/98: Amendment Number 1 |
| PART B | Last Revised 12/17/98: Amendment Number 1 |
| ATTACHMENT I | Last Revised 12/17/98: Amendment Number 1 |
| ATTACHMENT II | Original |
| ATTACHMENT III | Last Revised 12/17/98: Amendment Number 1 |
| ATTACHMENT IV | Original |
| ATTACHMENT V | Original |
| ATTACHMENT VI | Last Revised 12/17/98: Amendment Number 1 |
| ATTACHMENT VII | Original |
| ATTACHMENT VIII | Last Revised 12/17/98: Amendment Number 1 |
| ATTACHMENT IX | Original |
| ATTACHMENT X | Original |

MCI metro/Bell Atlantic
INTERCONNECTION AGREEMENT 1997

This MCI metro/Bell Atlantic Interconnection Agreement (the "Agreement"), effective on the date the Pennsylvania Public Utility Commission approves this Agreement, is entered into by and between MCI metro Access Transmission Services LLC ("MCI m"), a Delaware corporation, and Bell Atlantic-Pennsylvania, Inc. ("Bell Atlantic" or "BA"), a Pennsylvania corporation, to establish the rates, terms and conditions for the purchase and provision of Local Interconnection, Local Resale, unbundled Network Elements and other services, all as set forth in this Agreement (individually referred to as the "service" or collectively as the "services") for the purpose of the purchasing Party's provision of Telephone Exchange Service, Exchange Access Service, and/or Telecommunications Services.

WHEREAS, on February 8, 1996, the Communications Act of 1934, 47 U.S.C. § 151, *et seq.*, (the "Act") was amended by the Telecommunications Act of 1996; and

WHEREAS, the Act places certain duties and obligations upon, and grants certain rights to, Telecommunications Carriers and Local Exchange Carriers; and

WHEREAS, the Parties are Telecommunications Carriers and Local Exchange Carriers; and

WHEREAS, the Act places certain duties and obligations upon, and grants certain rights to, Incumbent Local Exchange Carriers, and Bell Atlantic is an Incumbent Local Exchange Carrier; and

WHEREAS, the Parties wish to interconnect their local exchange networks for the provision of Telephone Exchange Service, for the transmission and termination of local calls, so that subscribers of each can receive local calls that originate on the other's network and place local calls that terminate on the other's network, and for use in the provision of Exchange Access Service ("Local Interconnection"); and

WHEREAS, MCI m wishes to purchase Telecommunications Services for resale to others ("Local Resale" or "Services for Resale"), and Bell Atlantic is willing to provide such service; and

WHEREAS, MCI m wishes to purchase on an unbundled basis Network Elements, and to use such services for the provision of Telecommunications Services to others, and Bell Atlantic is willing to provide such services on the terms set forth herein; and

WHEREAS, the Parties intend the rates, terms and conditions of this Agreement, and their performance of obligations thereunder, to comply with the Act, the Rules and Regulations of the Federal Communications Commission ("FCC"), and the orders, rules and regulations of the Pennsylvania Public Utility Commission (the "Commission");

NOW, THEREFORE, in consideration of the premises and the mutual covenants of this Agreement, and intending to be legally bound by this Agreement, the Parties hereby covenant and agree as follows:

PART A – GENERAL TERMS AND CONDITIONS

Section 1. Scope of this Agreement

1.1 This Agreement, consisting of Parts A, B and C, specifies the rights and obligations of each Party with respect to the purchase and sale of Local Interconnection, Local Resale and Network Elements. This PART A sets forth the general terms and conditions governing this Agreement. Capitalized terms used in this Agreement shall have the meanings defined in PART B – DEFINITIONS, or as otherwise elsewhere defined throughout this Agreement. PART C sets forth, among other things, descriptions of the services, pricing, technical and business requirements, and physical and network security requirements.

LIST OF ATTACHMENTS COMPRISING PART C:

- I. Price Schedule
- II. Local Resale
- III. Network Elements
- IV. Interconnection
- V. Collocation
- VI. Rights of Way
- VII. Number Portability
- VIII. Business Process Requirements
- IX. Security Requirements
- X. Performance Reporting

1.2 Bell Atlantic shall provide the services in any Technically Feasible Combination requested by MCI, pursuant to the terms of this Agreement and in accordance with the requirements of Applicable Law, or where appropriate, the Bona Fide Request ("BFR") process set forth in Section 25 (BFR Process for Further Unbundling) of Part A, except that Local Resale shall be provided pursuant to Attachment II. Neither Party shall discontinue or refuse to provide any service provided or required hereunder, except in accordance with the terms hereof, without the other Party's written agreement. Bell Atlantic shall not reconfigure, reengineer or otherwise redeploy its network in a manner which would impair MCI's ability to offer Telecommunications Services in the manner contemplated by this Agreement, the Act or the FCC's Rules and Regulations without providing notice of Network Changes in accordance with the Act and FCC Rules and Regulations.

1.3 The Parties acknowledge that some of the services, facilities and arrangements provided pursuant to this Agreement are or will be available under and subject to the

terms of the federal or state Tariffs of the Party providing them. To the extent that a Tariff of a Party applies to any service, facility or arrangement provided pursuant to this Agreement, the following shall apply:

1.3.1 The rates and charges set forth in Attachment I shall remain fixed for the term of this Agreement or until superseded by such rates (whether interim or permanent) as may be applied by the Commission, notwithstanding that either of such rates may be different from those set forth in any effective, pending or future Tariff of the providing Party, (including any changes or modifications to any such Tariff—or any new Tariff—filed after the Effective Date of this Agreement); provided, however, this Section 1.3.1 shall remain subject to Section 1.3.3.

1.3.2 This Agreement and any applicable Tariffs of either Party shall be construed whenever possible to avoid any conflict between them. The fact that a condition, term, right or obligation appears in the Agreement and not in a Tariff, or in a Tariff but not in the Agreement, shall not be interpreted as, or deemed grounds for finding, a conflict for the purposes of this Section 1.3.

1.3.3 Any change or modification to any Tariff (including any Tariff filed after the Effective Date hereof) filed by either Party that materially and adversely impacts the provision or receipt of services hereunder or which materially and adversely alters the terms hereof shall only be effective against the other Party to the extent permitted by: (i) that Party's written consent; or (ii) an affirmative order of the Commission. Each Party shall file any required Tariff revisions, modifications or amendments in order to comply with Applicable Law and to continue performance of this Agreement in a lawful manner.

1.4 Construction

1.4.1 For purposes of this Agreement, certain terms have been defined in Part B or elsewhere in this Agreement. These terms will have the meanings stated in this Agreement, which may differ from, or be in addition to, the normal definition of the defined word. A defined word intended to convey the meaning stated in this Agreement is capitalized when used. Other terms that are capitalized, and not defined in this Agreement, shall have the meaning stated in the Act.

1.4.2 Unless the context clearly indicates otherwise, any defined term which is defined or used in the singular shall include the plural, and any defined term which is defined or used in the plural shall include the singular.

1.4.3 The words "shall" and "will" are used interchangeably throughout this Agreement and the use of either indicates a mandatory requirement. The use of one or the other shall not mean a different degree of right or obligation for either Party.

1.4.4 Conflicts among terms in Parts A and B of this Agreement, the Attachments and the Exhibits thereto, and the Tariffs shall be resolved in accordance with the following order of precedence, where the document identified in Subsection "(i)" shall have the highest precedence: (i) Parts A and B of this Agreement; (ii) the Attachments and the Exhibits thereto; and (iii) the Tariffs. The fact that a matter is addressed in one of these documents, but not in another, shall not constitute a conflict for purposes of this Section 1.4.4.

Section 2. Regulatory Approvals

2.1 The Parties shall promptly submit this Agreement, and any amendment or modification hereof, to the Commission for approval in accordance with Section 252 of the Act. Following such submission, the Parties shall submit the Agreement to any other applicable governmental entity for any requisite approvals. In the event any governmental authority or agency rejects any provision hereof, the Parties shall negotiate promptly and in good faith such revisions as may reasonably be required to achieve approval.

2.2 In the event the FCC or the Commission promulgates rules or regulations, or issues orders, or a court of competent jurisdiction issues orders, which make unlawful any provision of this Agreement, or which materially reduce or alter the services required by statute or regulations and embodied in this Agreement, then the Parties shall negotiate promptly and in good faith in order to amend the Agreement to substitute contract provisions which conform to such rules, regulations or orders. In the event the Parties cannot agree on an amendment within thirty (30) days after the date any such rules, regulations or orders become effective, then the Parties shall resolve their dispute under the applicable procedures set forth in Section 24 (Dispute Resolution Procedures) hereof.

2.3 The Parties intend that any services requested by either Party relating to the subject matter of this Agreement that are not offered hereunder will be incorporated into this Agreement by amendment upon agreement by the Parties.

2.4 In the event that any legally effective legislative, regulatory, judicial or other legal action materially affects any material terms of this Agreement, or the ability of MCI or Bell Atlantic to perform any material terms of this Agreement, MCI or Bell Atlantic may, on thirty (30) days written notice (delivered not later than thirty (30) days following the date on which such action has become legally binding or has otherwise become legally effective) require that such terms be renegotiated, and the Parties shall renegotiate in good faith such mutually acceptable new terms as may be required.

2.5 When this Agreement is filed with the Commission for approval, the Parties will request that the Commission: (a) approve the Agreement, and (b) refrain from taking any action to change, suspend or otherwise delay implementation of the Agreement.

2.6 Each Party shall be responsible for obtaining and keeping in effect all FCC, Commission, franchise authority and other governmental approvals, that may be required in connection with the performance of its respective obligations under this Agreement.

Section 3. Term of Agreement

3.1 This Agreement shall become effective as of the Effective Date stated above and, except as otherwise provided in this Agreement, shall remain in effect until August 31, 2000, and thereafter until terminated as provided in this Agreement. At least one hundred eighty (180) days before the term expires, either Party shall file with the Commission any request for an extension of that term, and shall on the same day provide notice to the other Party. At least one hundred fifty (150) days before the term expires, the other Party shall respond to the requested extension. If for any reason a new agreement has not been reached by the end of the three-year term, the existing interconnection agreement shall continue, month-to-month, under the same terms and conditions, subject to a true-up, until resolved by the Commission.

3.2 This Agreement shall be effective between the Parties as of the Effective Date, notwithstanding the pendency of proceedings challenging the Commission's approval of the Agreement.

3.3 Each Party recognizes that the services being provided under this Agreement at the time of its termination may need to be continued without interruption thereafter, and that upon such termination, either Party may itself provide or retain another vendor to provide comparable services. Each Party agrees to cooperate in an orderly and efficient transition to the other Party or another vendor such that the level and quality of the services are not degraded, and to exercise reasonable efforts to effect an orderly and efficient transition.

3.4 Unless a service is required to be offered by a Party under Applicable Law, either Party may terminate any service provided under this Agreement upon thirty (30) days prior written notice to the other Party unless a different notice period or different conditions are specified in this Agreement (including, but not limited to, in an applicable Tariff or Applicable Law) for termination of such service, in which event such specified period and/or conditions shall apply. Upon termination of its purchase of a service by the purchasing Party, the purchasing Party shall pay any applicable termination charges specified in this Agreement. Upon termination of a Local Resale service by Bell Atlantic, MCI_m shall be entitled to continue providing the terminated service to MCI_m's subscribers on a grandfathered basis to the same extent, and subject to the same terms and conditions, as would apply to such subscribers if they had been subscribers of Bell Atlantic for the terminated service at the time the service is terminated, and Bell Atlantic shall continue to provide such services to MCI_m on the same basis.

3.5 Following the expiration of this Agreement, this Agreement shall remain in effect as to any Expiring Service for the remainder of any contract period applicable to such Expiring Service at the time of the expiration of this Agreement. If an Expiring Service

is terminated prior to the expiration of the contract period applicable to such Expiring Service, MCI shall pay any termination charge provided for in this Agreement, in an applicable Tariff, or in the contract applicable to the Expiring Service. Following expiration of the applicable contract period for an Expiring Service, the Expiring Service, until terminated, shall be subject to: (i) any effective agreement superseding this Agreement; or (ii) to the extent such Expiring Service is not covered by such superseding agreement, applicable Tariffs. For the purposes of this Section 3.5, "Expiring Service" means: (a) any Local Resale service that, upon expiration of the term of this Agreement, is being provided under this Agreement and is subject to a remaining contract period greater than one (1) month; or (b) any Local Resale service: (i) for which an order has been submitted and accepted pursuant to this Agreement prior to the expiration of this Agreement but such service is not being provided at the expiration of this Agreement; and (ii) that is subject to an initial contract period which is greater than one (1) month.

Section 4. Charges and Payment

4.1 In consideration of the services provided under this Agreement, the purchasing Party shall pay the charges set forth in Attachment I. The billing and payment procedures for charges incurred by a purchasing Party hereunder are set forth in Attachment VIII.

Section 5. Assignment

5.1 Any assignment or delegation by either Party to any non-affiliated entity of any right, obligation or duty, or of any other interest hereunder, in whole or in part, without the prior written consent of the other Party shall be void (except the assignment of a right to moneys due or to become due). A Party assigning or delegating this Agreement or any right, obligation, duty or other interest hereunder to an Affiliate shall provide written notice to the other Party. All obligations and duties of any Party under this Agreement shall be binding on all successors in interest and assigns of such Party. No assignment or delegation hereof shall relieve the assignor of its obligations under this Agreement.

5.2 If any obligation of either Party is performed by a subcontractor or Affiliate, such Party shall remain fully responsible for the performance of this Agreement in accordance with its terms.

Section 6. Compliance with Laws

6.1 Each Party shall perform terms, conditions and operations under this Agreement in a manner that complies with all Applicable Law, including all regulations and judicial or regulatory decisions of all duly constituted governmental authorities of competent jurisdiction. Each Party shall be responsible for obtaining and keeping in effect all FCC, state regulatory commission, franchise authority and other regulatory approvals that may be required in connection with the performance of its obligations under this Agreement. Each Party shall reasonably cooperate with the other in obtaining and maintaining any approvals required by this Section. In the event the Act or FCC Rules and Regulations

applicable to this Agreement are held invalid, this Agreement shall survive, and the Parties shall promptly renegotiate any provisions of this Agreement which, in the absence of such invalidated Act, Rule or Regulation, are insufficiently clear to be effectuated.

6.2 Except as otherwise specified in this Agreement, each Party shall be responsible for: (i) all costs and expenses it incurs in complying with its obligations under this Agreement; and (ii) the development, modification, technical installation and maintenance of any systems or other infrastructure which it requires to comply with and to continue complying with its responsibilities and obligations under this Agreement.

Section 7. Governing Law

7.1 The validity of this Agreement, the construction and enforcement of its terms, and the interpretation of the rights and duties of the Parties, shall be governed by the Act and the laws of the Commonwealth of Pennsylvania, without regard to its conflicts of laws rules.

Section 8. Relationship of Parties

8.1 Each Party is an independent contractor, and has and hereby retains the right to exercise full control of and supervision over its own performance of its obligations under this Agreement.

8.2 Each Party retains full control over the employment, direction, compensation and discharge of all of its employees, agents and contractors assisting in the performance of its obligations under this Agreement. Each Party will be solely responsible for all matters relating to payment of its employees, agents and contractors, and payment of Social Security and other taxes in association with such employees, agents and contractors, and withholding and remittance of taxes from such employees, agents and contractors.

8.3 Nothing contained within this Agreement shall:

8.3.1 Make either Party the agent, servant or employee, of the other Party;

8.3.2 Grant either Party the authority to enter into a contract on behalf of, or otherwise legally bind, the other Party in any way;

8.3.3 Create a partnership, joint venture, or other similar relationship between the Parties; or

8.3.4 Grant to either Party a franchise, distributorship, or similar interest.

8.4 The relationship of the Parties under this Agreement is a non-exclusive relationship. Each Party shall have the right:

8.4.1 To provide services to be provided by it under this Agreement to persons other than the other Party; and

8.4.2 To purchase services which can be purchased by it under this Agreement from persons other than the other Party.

Section 9. No Third Party Beneficiaries

9.1 Except as may be specifically set forth in this Agreement, this Agreement does not provide and shall not be construed to provide any third parties (including, but not limited to, subscribers or subcontractors of a Party) with any right, remedy, claim, reimbursement, cause of action, or other privilege. The provisions of this Agreement are for the benefit of the Parties hereto and not for any other person, provided, however, that this shall not be construed to prevent either Party from providing its Telecommunications Services to any entities.

Section 10. Intellectual Property Rights

10.1 Any intellectual property which originates from or is developed by a Party shall remain in the exclusive ownership of that Party. Except for a limited license to use a Party's patents or copyrights to the extent necessary for the Parties to use any facilities or equipment (including software) or to receive any service solely as provided under this Agreement, no license in patent, copyright, trademark or trade secret, or other proprietary or intellectual property right now or hereafter owned, controlled or licensable by a Party, is granted to the other Party or shall be implied or arise by estoppel.

10.2 Bell Atlantic shall indemnify MCI_m with respect to MCI_m's use, pursuant to the terms of this Agreement, of intellectual property associated with any new Bell Atlantic network equipment or software acquisitions. Bell Atlantic warrants that it will not enter into any licensing agreements with respect to new Bell Atlantic network equipment or software acquisitions that contain provisions that would disqualify MCI_m from using or interconnecting with such network equipment or software pursuant to the terms of this agreement. Bell Atlantic also warrants that it has not and will not intentionally modify any existing licensing agreements for existing network equipment or software in order to disqualify MCI_m from using or interconnecting with such network equipment or software pursuant to the terms of this agreement. To the extent that the providers of equipment or software in Bell Atlantic's network provide Bell Atlantic with indemnities covering intellectual property liabilities and those indemnities allow a flow through of protection to third parties, Bell Atlantic shall flow those indemnity protections through to MCI_m. Bell Atlantic will inform MCI_m of any pending or threatened intellectual property claims relating to Bell Atlantic's network of which Bell Atlantic is aware and will update that notification periodically as needed, so that MCI_m receives maximum notice of any intellectual property risks it might want to address. Notwithstanding any part of this Section 10, MCI_m retains the right to pursue legal remedies against Bell Atlantic if Bell Atlantic is at fault in causing intellectual property liability to MCI_m.

10.2.1 For purposes of Section 10.2, Bell Atlantic's obligation to indemnify shall include the obligation to indemnify and hold MCI^m harmless from and against any loss, cost, expense or liability arising out of a claim that MCI^m's use, pursuant to the terms of this Agreement, of such new Bell Atlantic network equipment or software infringes the intellectual property rights of a third party. Moreover, should any such network equipment or software or any portion thereof provided by Bell Atlantic hereunder become, or, in Bell Atlantic's reasonable opinion, be likely to become, the subject of a claim of infringement, or should MCI^m's use thereof be finally enjoined, Bell Atlantic shall, at its immediate expense and at its choice:

10.2.1.1 Procure for MCI^m the right to continue using such material; or

10.2.1.2 Replace or modify such material to make it non-infringing provided such replacement or modification is functionally equivalent.

10.3 Unless otherwise mutually agreed upon, neither Party shall publish or use the other Party's logo, trademark, or service mark in any product, service, advertisement, promotion, or any other publicity matter, except that nothing herein shall prohibit lawful comparative advertising or comparative marketing.

Section 11. Indemnification

11.1 Each Party agrees to release, indemnify, defend and hold harmless the other Party from and against all losses, claims, demands, damages, expenses, suits or other actions, or any liability whatsoever, including, but not limited to, costs and attorneys' fees (collectively, a "Loss") incurred by the indemnified Party to the extent that such Loss is: (a) suffered, made, instituted, or asserted by any other person, relating to personal injury to or death of any person, or for loss, damage to, or destruction of real and/or personal property, whether or not owned by others, incurred during the term of this Agreement and to the extent legally caused by the acts or omissions of the indemnifying Party, regardless of the form of action; or (b) suffered, made, instituted, or asserted by the indemnifying Party's own customer(s) against the indemnified Party arising out of the indemnified Party's provision of services to the indemnifying Party under this Agreement, except to the extent the Loss arises from a breach of this Agreement by the indemnified Party. Notwithstanding the foregoing indemnification, nothing in this Section 11 shall affect or limit any claims, remedies, or other actions the indemnifying Party may have against the indemnified Party under this Agreement, any other contract, or any applicable Tariff(s), regulations or laws.

11.2 MCI^m shall indemnify, defend and hold harmless Bell Atlantic, Bell Atlantic's Affiliates, and the directors, officers and employees of Bell Atlantic and Bell Atlantic's Affiliates, from and against any claim, demand, suit, action, judgment, liability, damage or loss (including reasonable costs, expenses and attorneys' fees on account thereof), that arises out of or results from: (i) MCI^m's negligent use or occupancy of a Bell Atlantic

NID; (ii) wiring, facilities, equipment or other apparatus, negligently installed by MCI in or on a Bell Atlantic NID, or negligently connected by MCI to a Bell Atlantic NID; or (iii) the negligent acts or omissions of MCI, MCI's Affiliates, or the employees, agents or contractors of MCI or MCI's Affiliates, in connection with a Bell Atlantic NID. Where the NID is not used by Bell Atlantic or another Telecommunications Carrier (except MCI) to provide service to the premise, MCI shall have the burden, as between Bell Atlantic and MCI, to rebut the presumption that the claim, demand, suit, action, judgment, liability, damage or loss arises from wiring, facilities, equipment or other apparatus, negligently installed by MCI in or on a Bell Atlantic NID, or negligently connected by MCI to a Bell Atlantic NID. For the purposes of this Section 11.2, references to "negligence" or "negligently" shall be read to also encompass acts of gross negligence and/or intentional misconduct.

11.3 The indemnification provided herein shall be conditioned upon:

11.3.1 The indemnified Party shall promptly notify the indemnifying Party of any action taken against the indemnified Party relating to the indemnification, provided that failure to notify the indemnifying Party shall not relieve it of any liability it might otherwise have under this Section 11 to the extent it was not materially prejudiced by such failure of notification.

11.3.2 The indemnifying Party shall have sole authority to defend any such action, including the selection of legal counsel, and the indemnified Party may engage separate legal counsel only at its sole cost and expense. In the event the indemnifying Party does not accept the defense of any such action, the indemnified Party shall have the right to employ counsel for its own defense at the expense of the indemnifying Party.

11.3.3 In no event shall the indemnifying Party settle or consent to any judgment pertaining to any such action without the prior written consent of the indemnified Party, which consent shall not be unreasonably withheld.

11.3.4 In any action for which indemnity is sought, the indemnified Party shall assert any and all provisions in applicable Tariffs that limit liability to third parties as a bar to any recovery by the third party claimant in excess of applicable limitations of liability.

11.3.5 The indemnified Party shall offer the indemnifying Party all reasonable cooperation and assistance in the defense of any such action.

Section 12. Limitation of Liability

12.1 Neither Party shall be liable to the other for any indirect, incidental, special or consequential damages arising out of or related to this Agreement or the provision of service hereunder. Notwithstanding the foregoing limitation, a Party's liability shall not

be limited by the provisions of this Section 12 in the event of its willful or intentional misconduct, including gross negligence. Bell Atlantic shall be liable to MCI for lost revenues resulting from Bell Atlantic's breach of this Agreement only to the same extent that Bell Atlantic's Tariffs provide liability for Bell Atlantic end user subscribers' revenue losses. A Party's liability shall not be limited with respect to its indemnification obligations.

Section 13. Warranties

13.1 As more specifically set forth herein, each Party shall perform its obligations hereunder at Parity, as defined in Part B of this Agreement, which definition is intended to embody the performance provisions set forth in 47 U.S.C. § 251, and any implementing regulations thereunder, as those provisions may apply to the Party and obligation in question.

13.2 As more specifically set forth in Attachment II, Bell Atlantic shall provide Local Resale at Parity.

13.3 As more specifically set forth in Attachment III, Bell Atlantic shall provide Network Elements at Parity.

13.4 As more specifically set forth in Attachment IV, Bell Atlantic shall provide Interconnection at Parity and on a Non-Discriminatory Basis. MCI shall provide Interconnection on a Non-Discriminatory Basis.

13.5 As more specifically set forth in Attachment V, Bell Atlantic shall provide Collocation in accordance with the legally effective rules, regulations and orders of the FCC and the Commission.

13.6 As more specifically set forth in Attachment VI, Bell Atlantic shall provide Non-Discriminatory access to poles, ducts, conduits, and ROW owned or controlled by Bell Atlantic, in accordance with the requirements of section 224 of the Act and legally effective rules, regulations and orders of the FCC and the Commission.

13.7 As more specifically set forth in Attachment VII, Bell Atlantic and MCI shall provide Interim Number Portability and Number Portability in accordance with the legally effective rules, regulations and orders of the FCC and the Commission.

13.8 As more specifically set forth in Attachment VIII, Bell Atlantic and MCI shall meet Business Process Requirements.

13.9 As more specifically set forth in Attachment VIII, Bell Atlantic shall provide Non-Discriminatory access to telephone numbers for as long as Bell Atlantic remains the code administrator for the North American Numbering Plan.

13.10 As more specifically set forth in Attachment VIII, Bell Atlantic and MCI shall provide dialing party in accordance with the legally effective rules, regulations and orders of the FCC and the Commission.

13.11 As more specifically set forth in Attachment IX, Bell Atlantic and MCI shall meet security requirements, to the extent applicable to the security requirement in question.

13.12 As more specifically set forth in Attachment X, Bell Atlantic shall provide performance reporting.

EXCEPT AS SET FORTH IN THIS AGREEMENT, NEITHER PARTY MAKES ANY WARRANTIES WITH RESPECT TO ITS SERVICES, WHETHER EXPRESS OR IMPLIED, WRITTEN OR ORAL, IN FACT OR IN LAW. THE WARRANTIES SET FORTH IN THIS AGREEMENT ARE A PARTY'S EXCLUSIVE WARRANTIES WITH RESPECT TO ITS SERVICES AND ARE IN LIEU OF ALL OTHER WARRANTIES, EXPRESS OR IMPLIED, WRITTEN OR ORAL, IN FACT OR IN LAW. EACH PARTY DISCLAIMS ANY AND ALL OTHER WARRANTIES WITH RESPECT TO ITS SERVICES, INCLUDING, BUT NOT LIMITED TO, WARRANTIES OF MERCHANTABILITY AND FITNESS FOR A PARTICULAR PURPOSE AND WARRANTIES AGAINST INFRINGEMENT.

Section 14. Notices

14.1 Except as otherwise provided herein, or where context or services dictate that immediate notice be given, all notices or other communication hereunder shall be deemed to have been duly given when made in writing and delivered in person or deposited in the United States mail, certified mail, postage prepaid, return receipt requested and addressed as follows:

To MCI: MCImetro Access Transmission Services LLC
 Attention: Vice President
 7900 Westpark Drive, 8th Floor
 McLean, VA 22102

Copy to: General Counsel
 MCI Communications Corporation
 1801 Pennsylvania Ave., N.W.
 Washington, DC 20006

To Bell Atlantic: Bell Atlantic Network Services, Inc.
 Attn: Vice President, Interconnection Services Policy &
 Planning
 1320 North Courthouse Road, 2nd Floor

Arlington, VA 22201

Copy to: Legal Department
Bell Atlantic Network Services, Inc.
Attention: Associate General Counsel
1320 North Courthouse Road, 8th Floor
Arlington, VA 22201

Copy to: Bell Atlantic - Pennsylvania, Inc.
Attn: Vice President & General Counsel
1717 Arch Street, 32nd Floor
Philadelphia, Pennsylvania 19103

If personal delivery is selected to give notice, a receipt of such delivery shall be obtained. The address to which notices or communications may be given to either Party may be changed by written notice given by such Party to the other pursuant to this Section 14.

Section 15. Technical References

15.1 The Parties agree that the Bell Atlantic technical references set forth in Appendix I to this Part A (Technical Reference Schedule) provide the current technical specifications for the services offered by Bell Atlantic under this Agreement. Bell Atlantic reserves the right with reasonable notification to revise its technical references for any reason including, but not limited to, laws or regulations, conformity with updates and changes in standards promulgated by various agencies, utilization of advances in the state of technical arts, or the reflection of changes in the design of any facilities, equipment, techniques, or procedures described or referred to in the technical references. Notification of changes that are made to the underlying Bell Atlantic services will be made in conformance with the requirements of Section 251(c)(5), Notice of Changes, of the Act, and the FCC's Rules and Regulations. The Parties acknowledge that the general technical references set forth below contain certain generally accepted industry guidelines for particular interface and performance parameters for telecommunications equipment used by LECs in the United States. Such accepted technical references may be used by LECs to specify suitable equipment and facilities components for use in their respective networks, to assure interoperability between components that collectively comprise such networks, and to specify the interface characteristics and typical end-to-end performance of certain services.

15.2 The Parties acknowledge that they and their vendors and suppliers derive guidance from such technical references, and make reasonable efforts to conform to them. Requests for specific performance, functionality, or capabilities not applied in a Party's network should be handled using the BFR process set forth in Section 25 (BFR Process for Further Unbundling) of this Part A.

15.3 If one or more of the technical requirements set forth in Appendix I are in conflict, the Parties shall reasonably agree on which requirement shall apply.

15.4 The Parties agree that they each intend, to the extent technically feasible and commercially reasonable, to conform generally to industry standards applicable to the Parties set by the OBF, within a reasonable time after publication of final standards. With respect to OBF and other industry standards, the Parties agree that they will negotiate in good faith the applicability, technical feasibility and commercial reasonableness for implementation of such standards for services and arrangements under the Agreement.

Section 16. Remedies

16.1 The obligations of the Parties and the services offered under this Agreement may be unique. Accordingly, in addition to any other available rights or remedies, either Party may sue in equity for specific performance.

16.2 In the event either Party fails to switch a subscriber to the other Party's service as requested through a service request from the other Party, within any applicable intervals set forth in this Agreement or required by Applicable Law, or erroneously switches the other Party's subscriber away from that Party, then such act (including the continued provision of Telecommunications Services to such subscriber by the Party erroneously switching or failing to switch) shall be deemed an improper change in subscriber carrier selection commencing with the time at which such Party erroneously failed to switch such subscriber, or erroneously switched such subscriber. If such an improper change in subscriber carrier selection should occur, the rights and obligations of the Parties shall be determined in accordance with the regulations pertaining to such conduct on the part of Interexchange Carriers as set forth in the FCC's Rules and Regulations, Part 64, Subpart K, as these may be amended from time to time. For the purpose of this Section, Bell Atlantic shall be deemed an Interexchange Carrier.

16.3 At such time as the FCC or other competent regulatory body adopts regulations implementing 47 U.S.C. Section 258 or otherwise adopt regulations applicable to illegal or improper changes in local service, then such regulations shall supersede those applicable to Interexchange Carriers for the purposes of this Section 16.

16.4 Unless otherwise specifically provided hereunder, all rights of termination, cancellation or other remedies prescribed in this Agreement, or otherwise available, are cumulative and are not intended to be exclusive of other remedies to which the injured Party may be entitled at law or equity.

Section 17. Waivers

17.1 A failure or delay of either Party (including any course of dealing or course of performance) to enforce any of the provisions of this Agreement, or any right or remedy

available under this Agreement or at law or in equity, or to require performance of any of the provisions of this Agreement, or to exercise any option provided under this Agreement, shall in no way be construed to be a waiver of such provisions, rights, remedies or options.

17.2 Waiver by either Party of any default by the other Party shall not be deemed a waiver of any other default.

Section 18. Survival

18.1 Any liabilities or obligations of a Party for acts or omissions occurring prior to the expiration, cancellation or termination of this Agreement, any obligation of a Party under any provision for indemnification or defense (including, but not limited to, any of Sections 10, 11, 12, 23, 24, 28 and 29), Section 3. "Termination", Section 22. "Confidential Information", any provision for limitation of liability, and any obligation of a Party under any other provisions of this Agreement which, by their terms, are contemplated to survive (or to be performed after) expiration, cancellation or termination of this Agreement, shall survive the expiration, cancellation or termination of the Agreement, but solely to the minimum extent necessary to effectuate such provisions or complete such performance.

Section 19. Force Majeure

19.1 Except as otherwise specifically provided in this Agreement (including, by way of illustration, circumstances where a Party is required to implement disaster recovery plans to avoid delays or failure in performance and the implementation of such plans was designed to avoid the delay or failure in performance), neither Party shall be liable for any delay or failure in performance of any part of this Agreement by it caused by acts or failures to act of the United States of America or any state, district, territory, political subdivision, or other governmental entity, acts of God or a public enemy, strikes, labor slowdowns, or other labor disputes, but only to the extent that such strikes, labor slowdowns, or other labor disputes also affect the performing Party, fires, explosions, floods, embargoes, earthquakes, volcanic actions, unusually severe weather conditions, wars, civil disturbances, or other causes beyond the reasonable control of the Party claiming excusable delay or other failure to perform ("Force Majeure Condition"). In the event of any such excused delay in the performance of a Party's obligation(s) under this Agreement, the due date for the performance of the original obligation(s) shall be extended by a term equal to the time lost by reason of the delay. In the event of such delay, the delaying Party shall perform its obligations at a performance level no less than that which it uses for its own operations. In the event of such performance delay or failure by Bell Atlantic, Bell Atlantic agrees to resume performance at Party and in a Non-Discriminatory manner.

19.2 If any Force Majeure Condition occurs, the Party whose performance fails or is delayed because of such Force Majeure Condition shall give prompt notice to the other

Party, and upon cessation of such Force Majeure Condition, shall give like notice and commence performance hereunder as promptly as reasonably practicable.

19.3 Notwithstanding Section 19.1, no delay or other failure by a Party to perform shall be excused pursuant to this Section by the delay or failure of a Party's subcontractors, materialmen, or suppliers to provide products or services to the Party, unless such delay or failure is itself the product of a Force Majeure Condition, and such products or services cannot be obtained by the Party from other persons on commercially reasonable terms.

Section 20. Publicity

20.1 Neither Party shall produce, publish, or distribute any press release or other publicity referring to the other Party in connection with this Agreement, without the prior written approval of the other Party, which approval shall not be unreasonably withheld.

Section 21. Default and Termination

21.1 If a Party ("Breaching Party") materially breaches a material provision of this Agreement (other than an obligation to make payment of any amount billed under this Agreement), and such breach continues for more than thirty (30) days after written notice thereof from the other Party ("Injured Party"), then, except as otherwise required by Applicable Law, the Injured Party shall have the right, upon notice to the Breaching Party, to terminate or suspend this Agreement and/or the provision of services.

21.2 If a purchasing Party fails to make a payment of any amount billed under this Agreement by the due date stated on the providing Party's bill and such failure continues for more than thirty (30) days after written notice thereof from the providing Party, then, except as provided in Section 21.3 or as otherwise required by Applicable Law, the providing Party shall have the right, upon notice to the purchasing Party, to terminate or suspend this Agreement and/or the provision of services.

21.3 Billing Disputes.

21.3.1 If a billing dispute arises concerning any charges billed pursuant to this Agreement by a providing Party to a purchasing Party, payments withheld or paid pending settlement of the dispute shall be subject to interest at the rate set forth in Bell Atlantic's interstate access tariff.

21.3.2 If the purchasing Party pays the bill in full by the payment due date and later initiates a billing dispute pursuant to Attachment VIII, Section 3.1.9, interest will apply as follows:

21.3.2.1 If the billing dispute is resolved in favor of the purchasing Party, the purchasing Party shall receive a credit from the providing Party. This credit will be an amount equal to the disputed amount, plus interest at the rate set forth in Bell Atlantic's interstate access tariff. This amount will

apply from the date of the purchasing Party's payment through the date on which the purchasing Party receives payment of the disputed amount and accrued interest from the providing Party.

21.3.2.2 If the dispute is resolved in favor of the providing Party, neither a late payment charge nor an interest charge is applicable.

21.3.3 If the purchasing Party withholds payment on the bill (in full or in part) and initiates a billing dispute pursuant to Attachment VIII, Section 3.1.9, interest will apply as follows:

21.3.3.1 If the billing dispute is resolved in favor of the providing Party, the purchasing Party shall pay the providing Party a payment equal to the amount withheld by the purchasing Party, plus interest at the rate set forth in Bell Atlantic's interstate access tariff. This amount will apply from the payment due date through the date on which the providing Party receives payment of the disputed amount and accrued interest from the purchasing Party.

21.3.3.2 If the dispute is resolved in favor of the purchasing Party, neither a late payment charge nor an interest charge is applicable.

21.4 Notwithstanding the foregoing, if a Party's material breach is for any failure to perform in accordance with this Agreement which materially and adversely affects the provision of service of the non-breaching Party's subscribers, the non-breaching Party shall give notice of the breach and the breaching Party shall cure such breach within ten (10) days or within a period of time equivalent to the applicable interval required by this Agreement, whichever is shorter, and if the breaching Party does not, the non-breaching Party may, as its sole option, terminate this Agreement or any parts hereof. The non-breaching Party shall be entitled to pursue all available legal and equitable remedies for such breach.

21.5 MCIIm may terminate this Agreement in whole or in part at any time for any reason upon sixty (60) days prior written notice, except with respect to termination of any particular service(s), in which case, upon thirty (30) days prior written notice. MCIIm's sole liability for such termination shall be payment of amounts due for services provided up to the date of termination, unless otherwise provided for in this Agreement or in a Tariff providing a termination liability or minimum term for a service.

21.6 In the event of any termination under this Section 21 and, if applicable, pursuant to Section 3.3, Bell Atlantic agrees to provide for an uninterrupted transition of the services Bell Atlantic is providing to MCIIm at the time of termination to MCIIm or another vendor designated by MCIIm, and MCIIm agrees to provide for an uninterrupted transition of services MCIIm is providing to Bell Atlantic at the time of termination to Bell Atlantic or another vendor designated by Bell Atlantic.

21.7 Notwithstanding any termination hereof, the Parties shall continue to comply with their obligations under the Act to provide interconnection in accordance with Applicable Law.

Section 22. Confidentiality

22.1 For the purposes of this Section 22, "Confidential Information" means the following information disclosed by one Party ("Discloser") to the other Party ("Recipient") in connection with this Agreement:

22.1.1 All information disclosed by either Party to the other pursuant to Attachments I-X of this Agreement arising from the performance of this Agreement, including, but not limited to, books, records, documents and other information disclosed in an audit performed pursuant to this Agreement; and

22.1.2 Such other information as is identified as Confidential Information in accordance with Section 22.2.

22.2 All information which is to be treated as Confidential Information under Section 22.1.2 shall:

22.2.1 If in written, graphic, electromagnetic, or other tangible form, be marked as "Confidential Information"; and

22.2.2 If oral, (i) be identified by the Discloser at the time of disclosure to be "Confidential Information", and (ii) be set forth in a written summary which identifies the information as "Confidential Information" and is delivered by the Discloser to the Recipient within ten (10) days after the oral disclosure.

22.2.3 Each Party shall have the right to correct an inadvertent failure to identify such oral information as Confidential Information by giving written notification within thirty (30) days after the information is disclosed. The Recipient shall, from that time forward, treat such information as Confidential Information.

22.3 In addition to any requirements imposed by law, including, but not limited to, 47 U.S.C. § 222, for a period of three (3) years from the receipt of Confidential Information from the Discloser, except as otherwise specified in this Agreement, the Recipient agrees:

22.3.1 To use the Confidential Information only for the purpose of performing under this Agreement, including, to the extent applicable, the planning and operation of the Recipient's network; and

22.3.2 To use the same degree of care that it uses with similar confidential information of its own, to hold the Confidential Information in confidence and to

disclose it to no one other than the directors, officers and employees of the Recipient and the Recipient's Affiliates, having a need to know the Confidential Information for the purpose of performing under this Agreement.

22.4 A Recipient may disclose the Discloser's Confidential Information to a third party agent or consultant, provided that prior to such disclosure the agent or consultant has executed a written agreement of non-disclosure and non-use comparable in scope to the terms of this Section 22.

22.5 The Recipient may make copies of Confidential Information only as reasonably necessary to perform its obligations and exercise its rights under this Agreement. All such copies shall bear the same copyright and proprietary rights notices as are contained on the original.

22.6 The Recipient shall return all Confidential Information defined in Section 22.1.2 in the format in which it was received from the Discloser, including any copies made by the Recipient, within thirty (30) days after a written request is delivered to the Recipient, and/or destroy all such Confidential Information, except for Confidential Information that the Recipient reasonably requires to perform its obligations under this Agreement. If the Recipient loses or makes an unauthorized disclosure of the Discloser's Confidential Information, it shall notify the Discloser immediately and use reasonable efforts to retrieve the lost or improperly disclosed information.

22.7 The requirements of this Section 22 shall not apply to Confidential Information:

22.7.1 Which was in the possession of the Recipient free of restriction prior to its receipt from the Discloser;

22.7.2 After it becomes publicly known or available through no breach of this Agreement by the Recipient, the Recipient's Affiliates, or the directors, officers, employees, agents, or contractors, of the Recipient or the Recipient's Affiliates;

22.7.3 After it is rightfully acquired by the Recipient free of restrictions on its disclosure;

22.7.4 Which is independently developed by personnel of the Recipient; or

22.7.5 To the extent the disclosure is required by law, or made to a court, or governmental agency for the purpose of enforcing its rights under this Agreement; provided the Discloser has been notified of an intended disclosure promptly after the Recipient becomes aware of a required disclosure or decides to make such a voluntary disclosure to enforce its rights, the Recipient undertakes reasonable, lawful measures to avoid disclosing the Confidential Information until the Discloser has had reasonable time to seek a protective order, and the Recipient

complies with any protective order that covers the Confidential Information to be disclosed.

22.8 Each Party's obligations to safeguard Confidential Information disclosed prior to expiration, cancellation or termination of this Agreement shall survive such expiration, cancellation or termination.

22.9 Confidential Information shall remain the property of the Discloser, and the Discloser shall retain all of the Discloser's right, title and interest in any Confidential Information disclosed by the Discloser to the Recipient. Except as otherwise expressly provided elsewhere in this Agreement, no license is granted by this Agreement with respect to any Confidential Information (including, but not limited to, under any patent, trademark, or copyright), nor is any such license to be implied, solely by virtue of the disclosure of any Confidential Information.

22.10 Each Party agrees that the Discloser would be irreparably injured by a breach of this Section 22 by the Recipient, the Recipient's Affiliates, or the directors, officers, employees, agents or contractors of the Recipient or the Recipient's Affiliates, and that the Discloser shall be entitled to seek equitable relief, including injunctive relief and specific performance, in the event of any breach of the provisions of this Section 22. Such remedies shall not be deemed to be the exclusive remedies for a breach of this Section 22, but shall be in addition to any other remedies available at law or in equity.

22.11 The provisions of this Section 22 shall be in addition to and shall not limit, alter, define or contradict any provisions of Applicable Law, including, but not limited to, 47 U.S.C. § 222, and are not intended to constitute a waiver by a Party of any right with regard to protection of the confidentiality of information (whether or not defined as "Confidential Information" for purposes of this Agreement) of the Party or its customers provided by Applicable Law.

22.12 Without in any way limiting the foregoing provisions of Section 22, each Party shall comply with 47 U.S.C. § 222, any implementing rules, regulations, and orders thereunder, and other federal and state rules and regulations addressing Customer Proprietary Network Information ("CPNI") and Carrier Information. A Party shall not access (including, but not limited to, through electronic interfaces and gateways provided under this Agreement), use or disclose CPNI or other customer information unless the Party has obtained any customer authorization required by Applicable Law for such access, use and/or disclosure. By accessing, using or disclosing CPNI or other customer information, a Party represents and warrants that the Party has obtained any customer authorization required by Applicable Law for such access, use or disclosure. A Party accessing, using or disclosing CPNI or other customer information shall upon request by the other Party provide proof of any customer authorization for such access, use or disclosure, required by Applicable Law (including, copies of any written authorization). Without limiting the foregoing provisions of this Section 22, where required by 47 U.S.C.

§ 222, or other provision of Applicable Law, a Party shall obtain a signed letter of authorization from the applicable end user in order to obtain CPNI or other customer information from the other Party.

22.13 Each Party ("Auditing Party") shall have the right to audit the other Party ("Audited Party"), to ascertain whether the Audited Party is complying with the requirements of Applicable Law and this Agreement with regard to the Audited Party's access to, and use and disclosure of, CPNI and other customer information, which is made available by the Auditing Party to the Audited Party under this Agreement. Any audit conducted under this Section 22.13 shall be conducted in accordance with Section 23, "Audits and Inspections". Any information disclosed by the Audited Party to the Auditing Party or the Auditing Party's employees, Agents or contractors, in an audit conducted under this Section 22.13 shall be considered to be Confidential Information under this Section 22.

22.14 To the extent permitted by Applicable Law, each Party ("Auditing Party") shall have the right to monitor the access of the other Party ("Audited Party") to CPNI and other customer information which is made available by the Auditing Party to the Audited Party under this Agreement, to ascertain whether the Audited Party is complying with the requirements of Applicable Law and this Agreement with regard to the Audited Party's access to, and use and disclosure of, such CPNI and other customer information. To the extent permitted by Applicable Law, the foregoing right shall include, but not be limited to, the right to electronically monitor the Audited Party's access to and use of CPNI and other customer information which is made available by the Auditing Party to the Audited Party under this Agreement through electronic interfaces or gateways, to ascertain whether the Audited Party is complying with the requirements of Applicable Law and this Agreement with regard to the Audited Party's access to, and use and disclosure of, such CPNI and other customer information.

22.15 Nothing herein shall be construed as limiting the rights of either Party with respect to its own subscriber information under any Applicable Law, including without limitation Section 222 of the Act.

Section 23. Audits and Examinations

23.1 As applicable consistent with the provision of the relevant services or functions by a Party under this Agreement, each Party may audit the other Party's books, records and documents for the purpose of evaluating the accuracy of the other Party's bills and performance reports rendered under this Agreement. Such audits may be performed no more than a total of four (4) times in a calendar year nor more often than once every nine (9) months for a specific subject matter area; provided, that particular subject matter audits may be conducted more frequently (but no more frequently than once in each calendar quarter) if the immediately prior audit for such area found previously uncorrected net inaccuracies or errors in billing or performance reporting in favor of the audited Party having an aggregate value of at least five percent (5%) of the amounts

payable by the auditing Party, or statistics reportable by the audited Party, relating to services provided by the audited Party during the period covered by the audit.

23.2 In addition to the audits described in Section 23.1, each Party may audit the other Party's books, records and documents for the purpose of evaluating compliance with CPNI where the audited Party has access to CPNI in the custody of the auditing Party pursuant to this Agreement. Such CPNI audits must be performed in a minimally disruptive fashion, and an audited Party may bring objections to the Commission, if the audits are unnecessarily intrusive and the Parties cannot resolve their disputes. Such CPNI audits may not be performed more frequently than annually; provided, however, that the frequency of CPNI audits may be increased to quarterly if violations of a Party's CPNI obligations exceeds five percent (5%) of the audit sample.

23.3 The auditing Party may employ other persons or firms for this purpose. Such audit shall take place at a time and place agreed on by the Parties; provided, that the auditing Party may require that the audit commence no later than sixty (60) days after the auditing Party has given notice of the audit to the other Party.

23.4 The audited Party shall promptly correct any error that is revealed in a billing audit, including back-billing of any underpayments and making a refund, in the form of a billing credit, of any over-payments. Such back-billing and refund shall appear on the audited Party's bill no later than the bill for the third full billing cycle after the Parties have agreed upon the accuracy of the audit results.

23.5 Each Party shall cooperate fully in any audits required hereunder, providing reasonable access to any and all employees, books, records and documents, reasonably necessary to assess the accuracy of the audited Party's bills or performance reports, or compliance with CPNI obligations, as appropriate.

23.6 Audits shall be performed at the auditing Party's expense, provided that there shall be no charge for reasonable access to the audited Party's employees, books, records and documents necessary to conduct the audits provided for hereunder.

23.7 Books, records, documents, and other information, disclosed by the audited Party to the auditing Party or the Auditing Party's employees, agents or contractors in an audit under this Section 23, shall be deemed to be Confidential Information under Section 22.

23.8 This Section 23 shall survive expiration or termination of this Agreement for a period of two (2) years after expiration or termination of this Agreement.

Section 24. Dispute Resolution Procedures

24.1 In the event the Commission retains continuing jurisdiction to implement and enforce the terms and conditions of this Agreement, the Parties agree that any dispute arising out of or relating to this Agreement that the Parties themselves cannot resolve,

PART A

may be submitted to the Commission for resolution. The Parties agree to seek expedited resolution by the Commission, pursuant to applicable procedures established by the Commission. During the Commission proceeding, each Party shall continue to perform its obligations under this Agreement; provided, however that neither Party shall be required to act in any unlawful fashion. This provision shall not preclude the Parties from seeking relief available in any other forum.

24.2 The Parties acknowledge that the terms of this Agreement were established pursuant to an order of the Commission. Any and all of the terms of this Agreement may be altered or abrogated by a successful challenge to the Agreement (or to the order approving the Agreement) as permitted by Applicable Law. By signing this Agreement, the Parties do not waive the right to pursue such a challenge.

Section 25. Bona Fide Request Process for Further Unbundling

25.1 The Parties recognize that, because MCI plans to maintain a technologically advanced network, it is likely to seek further unbundling of Network Elements or the introduction of new Network Elements. Accordingly, MCI may request such new unbundled Network Elements or arrangements from time to time by submitting a request in writing ("Bona Fide Request" or "BFR"). Bell Atlantic shall promptly consider and analyze MCI's submission of a Bona Fide Request that Bell Atlantic provide: (a) a method of Interconnection or access to a Network Element not otherwise provided under this Agreement at the time of such Bona Fide Request; (b) a method of Interconnection or access to a Network Element that is different in quality to that which Bell Atlantic provides to itself, its Affiliates, or its subscribers at the time of such request; (c) Collocation at a location other than a Bell Atlantic Central Office; and (d) such other arrangement, service, or Network Element for which a Bona Fide Request is required under this Agreement. Items (a) through (d) above may be referred to individually as a "BFR Item." The Bona Fide Request process set forth herein does not apply to those services requested pursuant to Report & Order and Notice of Proposed Rulemaking 91-141 (rel. October 19, 1992), Paragraph 259 and Footnote 603 or subsequent orders.

25.2 A Bona Fide Request shall be submitted in writing and shall contain information required to perform a preliminary analysis of the requested BFR Item. Such information will include a technical description of each BFR Item and reasonable estimates of the number or volume requested, the location(s) of each BFR Item, and the date(s) each BFR Item is desired. MCI shall submit each BFR via United States Postal Service or private courier, return receipt requested.

25.3 MCI may cancel a Bona Fide Request at any time, but shall pay Bell Atlantic's reasonable and demonstrable costs of processing and/or implementing the Bona Fide Request up to the date of cancellation; except MCI shall not be charged for preliminary analysis if costs do not exceed one hundred dollars (\$100). Bell Atlantic shall notify MCI if costs will exceed five thousand dollars (\$5,000). Bell Atlantic shall provide

MCIIm with weekly status reports on the progress of its analysis and shall include the cost of such status reports in the costs of processing the BFR.

25.4 Within fifteen (15) business days after its receipt of a Bona Fide Request, Bell Atlantic shall provide to MCIIm a preliminary analysis of the BFR Item. The preliminary analysis shall respond in one of the following ways:

25.4.1 confirm that Bell Atlantic will offer the BFR Item and identify the date (no more than ninety (90) days after the date of the preliminary analysis) when Bell Atlantic will deliver a firm price proposal, including service description, pricing and an estimated schedule for availability ("Bona Fide Request Price Proposal");

25.4.2 provide a detailed explanation that such BFR Item is not technically feasible and/or that the BFR Item does not qualify as one that is required to be provided under the Act;

25.4.3 inform MCIIm that Bell Atlantic must do laboratory testing to determine whether the BFR Item is technically feasible;

25.4.4 inform MCIIm that Bell Atlantic must do field testing to determine whether the BFR Item is technically feasible;

25.4.5 inform MCIIm that it is necessary for the Parties to undertake a joint technical/operational field test in order to determine both technical feasibility and operational cost impacts of the BFR Item; or

25.4.6 request face-to-face meetings between technical representatives of both Parties to further explain the BFR Item. No later than five (5) business days following such meetings, Bell Atlantic will provide a preliminary analysis in one of the ways identified in Sections 25.4.1 through 25.4.5. Both Parties shall make reasonable efforts to schedule such meetings as expeditiously as possible.

25.5 Within ten (10) business days after receiving Bell Atlantic's preliminary analysis from Section 25.4.3, 25.4.4, or 25.4.5, MCIIm shall:

25.5.1 in the case of Sections 25.4.3 or 25.4.4, (i) negotiate a mutually agreeable, reasonably expeditious schedule for Bell Atlantic's testing, (ii) a mutually agreeable date (no more than ninety (90) days after the testing has shown the BFR Item is technically feasible) when Bell Atlantic will deliver a Bona Fide Request Price Proposal, and (iii) a mutually agreeable arrangement for sharing the testing costs; or

25.5.2 in the case of Section 25.4.5, (i) negotiate a mutually agreeable, reasonably expeditious schedule for joint technical/operational field testing, (ii) a mutually agreeable date (no more than 90 days after the testing has shown the

BFR Item is technically feasible) when Bell Atlantic will deliver a Bona Fide Request Price Proposal, and a mutually agreeable arrangement for sharing the testing costs.

25.6 In handling a Bona Fide Request pursuant to Section 25.4, Bell Atlantic shall, to the extent possible, utilize information from previously developed Bona Fide Requests in order to shorten its response times. MCI may take advantage of previously canceled BFR work performed by Bell Atlantic on the same BFR Item or a substantially similar BFR Item, to the extent applicable.

25.7 Within ten (10) business days after receiving Bell Atlantic's preliminary analysis from Section 25.4.1, MCI shall:

25.7.1 accept Bell Atlantic's date to deliver a Bona Fide Request Price Proposal;

25.7.2 negotiate as expeditiously as possible a different date for Bell Atlantic to deliver a Bona Fide Request Price Proposal; or

25.7.3 cancel the Bona Fide Request.

25.8 Unless the Parties otherwise agree, a BFR Item shall be priced in accordance with Section 252(d)(1) of the Act and any applicable FCC or Commission rules, regulations, or orders. Consistent with Applicable Law, the price for each BFR Item shall include the reasonable and demonstrable costs incurred by Bell Atlantic in responding to the BFR, to the extent that Bell Atlantic has not previously been reimbursed for such costs.

25.9 Within ninety (90) days after its receipt of the Bona Fide Request Price Proposal, MCI must either place an order for such BFR Item pursuant to the Bona Fide Request Price Proposal or, if it believes such Bona Fide Request Price Proposal is inconsistent with the requirements of the Act, seek arbitration by the Commission, including the use of any available expedited procedures. If, within ninety (90) days after its receipt of the Bona Fide Request Price Proposal, MCI fails to confirm an order for such BFR Item or seek arbitration by the Commission, Bell Atlantic may treat the Bona Fide Request as canceled by MCI. If within ninety (90) days after issuance of a Commission order finding that a Bona Fide Request Price Proposal is consistent with the requirements of the Act, MCI fails to place an order for such BFR Item, Bell Atlantic may treat the Bona Fide Request as canceled by MCI.

25.10 If a Party to a Bona Fide Request believes that the other Party is not requesting, or negotiating, or processing the Bona Fide Request in good faith, or disputes a determination, or price or cost quote, or is failing to act in accordance with Section 251 of the Act, such Party may seek mediation or arbitration by the Commission, including the use of any available expedited procedures, after giving the other Party written notice at least ten (10) days in advance.

Section 26. Branding

26.1 In all cases in which a Party has control over handling of services provided to customers of the other Party using services procured under this Agreement, the Party so handling such services shall brand them at the points of subscriber contact as set forth in Attachment VIII.

26.2 When Bell Atlantic technicians (including Bell Atlantic contractor technicians) have contact with a customer during a premise visit on behalf of MCIIm, the Bell Atlantic technicians shall identify themselves as Bell Atlantic employees (or Bell Atlantic contractor employees) performing services on behalf of MCIIm. When a Bell Atlantic technician leaves a status card during a premise visit on behalf of MCIIm, the card will be a standard card used for other local service providers' customers, will be in substantially the form set forth in Exhibit A of this Part A, and will include the name and telephone number of each local service provider that elects to be listed on the card and agrees to compensate Bell Atlantic for that provider's share of Bell Atlantic's cost of printing and distributing the card. The Bell Atlantic technicians shall not leave any promotional or marketing literature for or otherwise market Bell Atlantic Telecommunications Services to the MCIIm customer during a premise visit on behalf of MCIIm, but may provide a telephone number for Bell Atlantic's customer service or sales department, in response to customer query about Bell Atlantic services.

26.3 This Section 26 shall not confer on either Party any rights to the service marks, trademarks and trade names owned by or used in connection with services by the other Party or its Affiliates, except as expressly permitted by this Section 26.

Section 27. Taxes

27.1 With respect to any purchase of services under this Agreement, if any Federal, state or local government tax, fee, duty, surcharge (including, but not limited to, any 911, telecommunications relay service, or universal service fund surcharge), or other tax-like charge (a "Tax") is required or permitted by Applicable Law to be collected from a Purchasing Party by the Providing Party, then: (i) the Providing Party shall bill the Purchasing Party for such Tax; (ii) the Purchasing Party shall timely remit such Tax to the Providing Party; and (iii) the Providing Party shall remit such collected Tax to the applicable taxing authority.

27.2 With respect to any purchase of services under this Agreement, if any Tax is imposed by Applicable Law on the receipts of the Providing Party, which Applicable Law permits the Providing Party to exclude certain receipts received from sales of services for resale by the Purchasing Party, such exclusion being based solely on the fact that the Purchasing Party is also subject to a tax based upon receipts ("Receipts Tax"), then the Purchasing Party (i) shall provide the Providing Party with notice in writing in accordance with Section 27.7 of its intent to pay the Receipts Tax, and (ii) shall timely pay the Receipts Tax to the applicable taxing authority.

27.3 With respect to any purchase of services under this Agreement, that are resold by the Purchasing Party to a subscriber of the Purchasing Party, if any Tax is imposed by Applicable Law on the subscriber of the Purchasing Party in connection with its purchase of the resold Offered Services which the Purchasing Party is required to impose and/or collect from the subscriber, then the Purchasing Party (i) shall impose and/or collect such Tax from the subscriber, and (ii) shall timely remit such Tax to the applicable taxing authority.

27.3.1 If the Providing Party has not received an exemption certificate from the Purchasing Party and fails to collect any Tax as required by Section 27.1, then, as between the Providing Party and the Purchasing Party, (i) the Purchasing Party shall remain liable for such uncollected Tax, and (ii) the Providing Party shall be liable for any interest and/or penalty assessed on the uncollected Tax by the applicable taxing authority.

27.3.2 If the Providing Party properly bills the Purchasing Party for any Tax but the Purchasing Party fails to remit the Tax to the Providing Party as required by Section 27.1, then, as between the Providing Party and the Purchasing Party, the Purchasing Party shall be liable for such uncollected Tax and any interest and/or penalty assessed on the uncollected Tax by the applicable taxing authority. The Providing Party shall give timely notice to the Purchasing Party if any proposed assessment of Taxes, interest or penalties by the applicable taxing authority so as to afford the Purchasing Party an opportunity to cure any defect or inadequacy with its exemption certificate before assessment of any additional Taxes, interest or penalties is made by the taxing authority.

27.3.3 If the Providing Party does not collect a Tax because the Purchasing Party has provided the Providing Party with an exemption certificate which is later found to be inadequate by the applicable taxing authority, then, as between the Providing Party and the Purchasing Party, the Purchasing Party shall be liable for such uncollected Tax and any interest and/or penalty assessed on the uncollected Tax by the applicable taxing authority.

27.3.4 Except as provided in Section 27.3.5, if the Purchasing Party fails to pay the Receipts Tax as required by Section 27.2, then, as between the Providing Party and the Purchasing Party, (i) the Providing Party shall be liable for any Tax imposed on the Providing Party's receipts, and (b) the Purchasing Party shall be liable for any Tax imposed on the Purchasing Party's receipts and any interest and/or penalty assessed by the applicable taxing authority on either the Purchasing Party or the Providing Party with respect to the Tax on the Providing Party's receipts.

27.3.5 If any discount or portion of a discount in price provided to the Purchasing Party under this Agreement (including, but not limited to, the discount provided for in Attachment I) represents Tax savings to the Providing Party which it was

assumed the Providing Party would receive, because it was anticipated that receipts from sales of services (that would otherwise be subject to a Tax on such receipts) could be excluded from such Tax under Applicable Law, because the services would be sold to a Telecommunications Services provider, and the Providing Party is, in fact, required by Applicable Law to pay such Tax on receipts from sales of services to the Purchasing Party, then, as between the Providing Party and the Purchasing Party, the Purchasing Party shall be liable for any such Tax and any interest and/or penalty assessed by the applicable taxing authority on either the Purchasing Party or the Providing Party with respect to the Tax on the Providing Party's receipts.

27.3.6 With respect to any Tax imposed on subscribers of the Purchasing Party that the Purchasing Party is required to collect, as between the Providing Party and the Purchasing Party, the Purchasing Party shall remain liable for such Tax and any interest and/or penalty assessed on such Tax by the applicable taxing authority.

27.4 If either Party is audited by a taxing authority, the other Party agrees to reasonably cooperate with the Party being audited in order to respond to any audit inquiries in a proper and timely manner so that the audit and/or any resulting controversy may be resolved expeditiously.

27.5 If Applicable Law clearly exempts a purchase of services under this Agreement from a Tax, and if such Applicable Law also provides an exemption procedure, such as an exemption certificate requirement, then, if the Purchasing Party complies with such procedure, the Providing Party shall not collect such Tax during the effective period of the exemption. Such exemption shall be effective upon receipt of the exemption certificate or affidavit in accordance with Section 27.7.

27.6 If Applicable Law appears to exempt a purchase of services under this Agreement from a Tax, but does not also provide an exemption procedure, then the Providing Party shall not collect such Tax if the Purchasing Party (i) furnishes the Providing Party with a letter signed by an officer of the Purchasing Party requesting an exemption and citing the provision in the Applicable Law which appears to allow such exemption, and (ii) supplies the Providing Party with an indemnification agreement, reasonably acceptable to the Providing Party, which holds the Providing Party harmless on an after-tax basis with respect to forbearing to collect such Tax.

27.7 All notices, affidavits, exemption certificates or other communications required or permitted to be given by either Party to the other under this Section 27, shall be made in writing and shall be delivered personally or sent by prepaid overnight express service, and sent to the addresses stated in Section 14 and to the following:

To Bell Atlantic: Tax Administration
Bell Atlantic Network Services, Inc.

1717 Arch Street, 30th Floor
Philadelphia, PA 19103

To MCIIm: MCI Carrier Group
MCI Telecommunications Corporation
1133 19th Street, NW
Washington, DC 20036

Either Party may from time-to-time designate another address or addressee by giving notice in accordance with the terms of this Section 27.7. Any notice or other communication shall be deemed to be given when received.

Section 28. Responsibility for Environmental Contamination

28.1 MCIIm shall in no event be liable to Bell Atlantic for any costs whatsoever resulting from a violation of a federal, state or local environmental law by Bell Atlantic, its contractors or agents arising out of this Agreement (a "Bell Atlantic Environmental Violation"). Bell Atlantic shall, at MCIIm's request, indemnify, defend, and hold harmless MCIIm, each of its officers, directors and employees from and against any losses, damages, claims, demands, suits, liabilities, fines, penalties and expenses (including reasonable attorneys fees) that are caused by a Bell Atlantic Environmental Violation.

28.2 Bell Atlantic shall in no event be liable to MCIIm for any costs whatsoever resulting from a violation of a federal, state or local environmental law by MCIIm, its contractors or agents arising out of this Agreement (an "MCIIm Environmental Violation"). MCIIm shall, at Bell Atlantic's request, indemnify, defend, and hold harmless Bell Atlantic, each of its officers, directors and employees from and against any losses, damages, claims, demands, suits, liabilities, fines, penalties and expenses (including reasonable attorneys fees) that are caused by an MCIIm Environmental Violation.

28.3 In the event any suspect materials within Bell Atlantic-owned, operated or leased facilities are identified to be asbestos-containing, MCIIm will ensure that to the extent any activities which it undertakes in the facility disturb such suspect materials, such MCIIm activities will be in accordance with applicable local, state and federal environmental and health and safety statutes and regulations. Except for abatement activities undertaken by MCIIm or equipment placement activities that result in the generation or placement of asbestos containing material, MCIIm shall not have any responsibility for managing, nor be the owner of, nor have any liability for, or in connection with, any asbestos containing material at Bell Atlantic-owned, operated or leased facilities. Bell Atlantic agrees to immediately notify MCIIm if Bell Atlantic undertakes any asbestos control or asbestos abatement activities that potentially could affect MCIIm equipment or operations, including, but not limited to, contamination of equipment.

Section 29. Facilities

29.1 A providing Party or its suppliers shall retain all right, title and interest in, and ownership of, all facilities, equipment, software, and wiring, used to provide the providing Party's services. During the period in which services are provided, the providing Party shall have access at all reasonable times to the purchasing Party's and the purchasing Party's customers' locations for the purpose of installing, maintaining, repairing, and inspecting all facilities, equipment, software, and wiring, used to provide the services. At the conclusion of the period in which services are provided, the providing Party shall have access at the purchasing Party's and the purchasing Party's customers' locations at all reasonable times to remove all facilities, equipment, software, and wiring used to provide the services. The purchasing Party shall, at the purchasing Party's expense, obtain any rights and authorizations necessary for such access.

29.2 Except as otherwise stated in this Agreement or agreed to in writing by a providing Party, a providing Party shall not be responsible for the installation, maintenance, repair or inspection, of facilities, equipment, software, or wiring furnished by the purchasing Party or the purchasing Party's customers for use with the providing Party's services.

Section 30. Option to Obtain Services Under Other Agreements

30.1 In accordance with the requirements of 47 U.S.C. § 252(i), each Party shall, upon written request by the other Party, make available to the requesting Party any interconnection, service, or network element provided under an agreement with a third party, and which is approved by the Commission pursuant to 47 U.S.C. § 252, upon the same terms and conditions (including prices) provided in the agreement with the third party. This Agreement shall thereafter be amended to incorporate the terms and conditions (including prices) from the third party agreement applicable to the interconnection, service, or network element that the requesting Party has elected to purchase pursuant to the terms and conditions of the third party agreement. The amended rates, terms and conditions from the third party agreement shall be effective upon: (i) amendment by the Parties, or (ii) sixty (60) days after the date of written request, whichever is earlier.

30.2 To the extent the exercise of the foregoing option requires a rearrangement of facilities by the providing Party, the requesting Party shall be liable for the non-recurring charges associated therewith, as well as for any termination charges, if any, associated with the termination of existing facilities or services.

Section 31. Other Services

31.1 This Agreement applies only to "services" as defined in this Agreement. To the extent that services subscribed to under this Agreement by a purchasing Party are interconnected to or used with other services, facilities, equipment, software, or wiring, provided by the providing Party or by other persons, such other services, facilities,

equipment, software, or wiring, shall not be construed to be provided under this Agreement. Any providing Party services, facilities, equipment, software, or wiring, to be used by the purchasing Party which are not subscribed to by the purchasing Party under this Agreement must be subscribed to by the purchasing Party separately, pursuant to other written agreements (including, but not limited to, applicable providing Party Tariffs).

31.2 Without in any way limiting Section 31.1, the Parties agree that this Agreement does not apply to the following Bell Atlantic services and products: Bell Atlantic Answer Call, Bell Atlantic Answer Call Plus, Bell Atlantic Basic Mailbox, Bell Atlantic Voice Mail, and other Bell Atlantic voice mail and voice messaging services; Bell Atlantic Optional Wire Maintenance Plan, Bell Atlantic Guardian Enhanced Maintenance Service, Bell Atlantic Sentry I Enhanced Maintenance Service, Bell Atlantic Sentry II Enhanced Maintenance Service, Bell Atlantic Sentry III Enhanced Maintenance Service, and other inside wire maintenance services; customer premises equipment; Telephone Directory advertisements (except as stated in Attachment VIII); and any service that incorporates the payphone station equipment.

31.3 Without in any way limiting Section 31.1 or Section 31.2, the Parties also agree that this Agreement does not apply to the installation, maintenance, repair, inspection, or use of any facilities, equipment, software, or wiring, located on the purchasing Party's side of the Network Rate Demarcation Point applicable to the purchasing Party and does not grant to the purchasing Party a right to installation, maintenance, repair, inspection, or use, of any such facilities, equipment, software, or wiring. Installation, maintenance, repair, inspection, or use of facilities, equipment, software, or wiring, located on the purchasing Party's side of the Network Rate Demarcation Point applicable to the purchasing Party must be contracted for by the purchasing Party separately, pursuant to other written agreements, at rates stated in such other written agreements.

Section 32. Provision and Use of Services

32.1 A Party may fulfill its obligations under this Agreement itself or may cause an Affiliate of the Party to take the action necessary to fulfill the Party's obligations; provided that a Party's use of an Affiliate to perform this Agreement shall not release the Party from any liability or duty to fulfill its obligations under this Agreement.

32.2 Except as otherwise expressly stated in this Agreement, each Party, at its own expense, shall be responsible for obtaining from governmental authorities, property owners, other Telecommunications Carriers, and any other persons or entities, all rights and privileges (including, but not limited to, Rights of Way, space and power), which are necessary for the Party to provide its services pursuant to this Agreement.

32.3 Except as otherwise provided in this Agreement, this Agreement does not prevent a purchasing Party from using the services provided by a providing Party pursuant to this Agreement in connection with other technically compatible services provided by the

providing Party pursuant to this Agreement or with any services provided by the purchasing Party or a third party, provided, however, that unless otherwise provided herein, interconnection services, call transport and termination services, and unbundled Network Elements shall be available under the terms and conditions (including prices) set forth in this Agreement and shall be used by the purchasing Party solely for purposes consistent with obligations set forth in the Act and any rules, regulations or orders thereunder.

Section 33. Selection of IntraLATA Telecommunications Service Provider

33.1 The Parties agree to apply the principles and procedures set forth in Sections 64.1100 and 64.1150 of the FCC Rules, 47 C.F.R. §§ 64.1100 and 64.1150, to the process for end user selection of an IntraLATA Telecommunications Service provider, provided that if the FCC or the Commission adopts rules governing the process for end user selection of an IntraLATA Telecommunications Service provider, the Parties shall apply such rules rather than the principles and procedures set forth in §§ 64.1100 and 64.1150.

33.2 In the event a Party ("Requesting Party") which requests the other Party to change an end user's Telecommunications Service (including, but not limited to, an end user's selection of an IntraLATA Telecommunications Service provider): (a) fails to provide documentary evidence of the end user's IntraLATA Telecommunications Service provider selection upon request; or (b) requests changes in the end user's Telecommunications Service without having obtained authorization for such change from the end user pursuant to the principles and procedures set forth in Sections 64.1100 and 64.1150 or other applicable FCC or Commission rules, the Requesting Party shall indemnify, defend and hold harmless the other Party for any resulting Claims. In addition, the Requesting Party shall be liable to the other Party for all charges that would be applicable to the end user for the initial change in the end user's Telecommunications Service and any charges for restoring the end user's Telecommunications Service to its end user authorized condition, including to the appropriate IntraLATA Telecommunications Service provider.

33.3 A Providing Party shall not require the Purchasing Party to produce a letter of authorization, disconnect order, or other writing, from the Purchasing Party's subscriber as a pre-condition to processing an Order from the Purchasing Party.

Section 34. Service Standards

34.1 Bell Atlantic shall provide service to MCI_m at a level of performance that Bell Atlantic is required by Applicable Law (including 47 U.S.C. § 251) to meet in providing service to MCI_m.

34.2 Bell Atlantic shall offer premium service (services provided at a higher level than that required by Section 34.1) to MCI_m, if MCI_m requests premium service in

accordance with Section 25 and MCI_m compensates Bell Atlantic for the incremental cost of providing such premium service.

34.3 Upon MCI_m's request, Bell Atlantic shall provide to MCI_m reports on all material measures of service Parity. MCI_m may request a report on all measures that are reasonably related to establishing the Parity level and whether MCI_m is receiving services at Parity. Such reports shall indicate for each material measure the service and performance level provided by Bell Atlantic to itself, its Affiliates, MCI_m, and other CLECs. The reports required by this Section 34 are identified in Attachment X of this Agreement.

34.4 To the extent Bell Atlantic through its Tariffs provides credits for substandard performance, Bell Atlantic shall provide MCI_m such credits for substandard performance of services provided under this Agreement.

34.5 Pursuant to Section 23 of this Part A, MCI_m shall have the right, at its expense, to conduct reasonable audits or other verifications of information and reports provided by Bell Atlantic under this Section 34.

Section 35. Subcontracting

35.1 If any obligation under this Agreement is performed through a subcontractor, the subcontracting Party shall remain fully responsible for the performance of this Agreement in accordance with its terms, including any obligations it performs through the subcontractor. The subcontracting Party shall be solely responsible for payments due its subcontractors. No subcontractor shall be deemed a third party beneficiary for any purposes under this Agreement.

Section 36. Amendments and Modifications

36.1 No provision of this Agreement shall be deemed waived, amended or modified by either Party unless such a waiver, amendment or modification is in writing, dated, and signed by both Parties.

Section 37. Severability

37.1 If any term, condition or provision of this Agreement is held to be invalid or unenforceable for any reason, such invalidity or unenforceability shall not invalidate the entire Agreement (unless such construction would be unreasonable), and the Agreement shall be construed as if it did not contain the invalid or unenforceable provision or provisions, and the rights and obligations of each Party construed and enforced accordingly.

Section 38. Headings Not Controlling

38.1 The headings of Articles and Sections of this Agreement are for convenience of reference only, and shall in no way define, modify or restrict the meaning or interpretation of the terms or provisions of this Agreement.

Section 39. Entire Agreement

39.1 This Agreement constitutes the entire agreement between the Parties on the subject matter hereof, and supersedes any prior or contemporaneous agreement, understanding, or representation on the subject matter hereof. Except as otherwise provided in this Agreement, the terms in this Agreement may not be waived or modified except by a written document which is signed by the Parties.

Section 40. Counterparts

40.1 This Agreement may be executed in any number of counterparts, each of which shall be deemed an original; but such counterparts shall together constitute one and the same instrument.

Section 41. Successors and Assigns

41.1 This Agreement shall be binding upon, and inure to the benefit of, the Parties hereto and their respective successors and permitted assigns.

Section 42. Good Faith Performance

42.1 In the performance of their obligations under this Agreement, the Parties shall cooperate fully and act in good faith and consistently with the intent of the Act. Where notice, approval or similar action by a Party is permitted or required by any provision of this Agreement (including, without limitation, the obligation of the Parties to further negotiate the resolution of new or open issues under this Agreement), such action shall not be unreasonably delayed, withheld or conditioned.

Section 43. Joint Work Product

43.1 This Agreement is the joint work product of the representatives of the Parties. For convenience, this Agreement has been drafted in final form by one of the Parties. Accordingly, in the event of ambiguities, no inferences shall be drawn against either Party solely on the basis of authorship of this Agreement.

IN WITNESS WHEREOF, each of the Parties has caused this Agreement to be executed by its duly authorized representatives.

MCImetro Access Transmission
Services, Inc.

Bell Atlantic-Pennsylvania, Inc.

By: /s/

By: /s/

Name: Dennis J. Kern

Name: Daniel J. Whelan

Title: Vice President

Title: President & CEO

Date: July 7, 1997

Date: July 8, 1997

APPENDIX I

TECHNICAL REFERENCE SCHEDULE

Bell Atlantic Technical References

- TR72565, Issue 1, 1996, Bell Atlantic Technical Reference - Basic Unbundled Loop Services - Technical Specifications (as set forth in Exhibit A, Attachment III).
- TR72570, Issue 1, 1996, Bell Atlantic Technical Reference - Analog Unbundled Loop Services with Customer Specified Signaling - Technical Specifications (as set forth in Exhibit B, Attachment III).
- TR72575, Issue 1, 1996, Bell Atlantic Technical Reference - Digital Unbundled Loop Services - Technical Specifications (as set forth in Exhibit C, Attachment III).
- TR72580, Issue 1, 1997, Bell Atlantic Technical Reference - Analog Unbundled Port Services - Technical Specifications (as set forth in Exhibit F, Attachment III).
- TR72585, Issue 1, 1997, Bell Atlantic Technical Reference - Digital Unbundled Port Services - Technical Specifications (as set forth in Exhibit G, Attachment III).
- BA905, Bell Atlantic Supplement Common Channel Signaling Network Interface Specification.

Local Loop

- ANSI/IEEE 743-1995, Standard Methods and Equipment for Measuring the Transmission Characteristics of Analog Voice Frequency Circuits.
- ANSI T1.102-1993, American National Standard for Telecommunication - Digital Hierarchy - Electrical Interfaces.
- ANSI T1.401-1993, American National Standard for Telecommunications - Interface Between Carriers and Customer Installations - Analog Voicegrade Switched Access Lines Using Loop-Start and Ground-Start Signaling.
- ANSI T1.403-1995, Network to Customer Installation - DSI Metallic Interface.
- ANSI T1.405-1996, Network-to-Customer Installation Interfaces - Direct-Inward-Dialing Analog Voice Grade Switched Access Using Loop Reverse-Battery Signaling.
- ANSI T1.601-1992, American National Standard for Telecommunications - ISDN - Basic Access Interface for Use on Metallic Loops for Application at the Network Side of NT, Layer 1 Specification.
- Bellcore TR-NWT-000057, Functional Criteria for Digital Loop Carrier Systems, Issue 2, January 1993.

Local Switching

- Bellcore FR-64-LATA, LATA Switching Systems Generic Requirements ("LSSGR"), 1996 Edition, Issue 1, January 1996.
- Bellcore TR-NWT-000008, Digital Interface Between the SLC®96 Digital Loop Carrier System and a Local Digital Switch, Issue 2, August 1987; and Revision 1, September 1993; and Bulletin 1, October 1994.
- Bellcore GR-303-CORE, Integrated Digital Loop Carrier System Generic Requirements, Objectives, and Interface, Issue 1, September 1995; and Revision 2, December 1996.
- Bellcore TR-NWT-000393, Generic Requirements for ISDN Basic Access Digital Subscriber Lines, Issue 2, January 1991.

Tandem Switching and Operator Services

- Bellcore TR-TSY-000540, LSSGR: Tandem Supplement, Section 20, Issue 2, July 1987; and Revision 1, December 1988; and Revision 2, June 1990.
- Bellcore GR-1149-CORE, OSSGR Section 10: System Interfaces, Issue 1, October 1995.
- Bellcore GR-1158-CORE, OSSGR Section 22.3: Line Information Database, Issue 2, October 1995.

SS7

- ANSI T1.110-1992, American National Standard Telecommunications - Signaling System Number 7 ("SS7") - General Information.
- ANSI T1.111-1992, American National Standard for Telecommunications - Signaling System Number 7 ("SS7") - Message Transfer Part ("MTP").
- ANSI T1.111A-1994, American National Standard for Telecommunications - Signaling System Number 7 ("SS7") - Message Transfer Part ("MTP") Supplement.
- ANSI T1.112-1992, American National Standard for Telecommunications - Signaling System Number 7 ("SS7") - Signaling Connection Control Part ("SCCP").
- ANSI T1.113-1995, American National Standard for Telecommunications - Signaling System Number 7 ("SS7") - Integrated Services Digital Network ("ISDN") User Part.
- ANSI T1.114-1992, American National Standard for Telecommunications - Signaling System Number 7 ("SS7") - Transaction Capabilities Application Part ("TCAP").
- ANSI T1.115-1990, American National Standard for Telecommunications - Signaling System Number 7 ("SS7") - Monitoring and Measurements for Networks.
- ANSI T1.116-1990, American National Standard for Telecommunications - Signaling System Number 7 ("SS7") - Operations, Maintenance and Administration Part ("OMAP").

- ANSI T1.118-1992, American National Standard for Telecommunications - Signaling System Number 7 ("SS7") - Intermediate Signaling Network Identification ("ISNI").
- Bellcore GR-246-CORE, Bell Communications Research Specification of Signaling System Number 7, Issue 1, December 1994; and Revision 1, December 1995; and Revision 2, December 1996.
- Bellcore GR-317-CORE, Switching System generic requirements for Call Control Using the Integrated Services Digital Network User Part ("ISDNUP"), Bellcore, February, 1994
- Bellcore GR-394-CORE, Switching System generic requirements for Interexchange Carrier Interconnection Using the Integrated Services Digital Network User Part ("ISDNUP"), Bellcore, February, 1994
- Bellcore GR-905-CORE, Common Channel Signaling Network Interface Specification ("CCSNIS") Supporting Network Interconnection, Message Transfer Part ("MTP"), and Integrated Services Digital Network User Part ("ISDNUP"), Issue 2, December 1996.
- Bellcore GR-954-CORE, Common Channel Signaling Network Interface Specification ("CCSNIS") Supporting Line Information Database ("LIDB") Services, Issue 1, June 1994; and Revision 1, October 1995.
- Bellcore GR-1428-CORE, Common Channel Signaling Network-Interface Specification ("CCSNIS") Supporting Toll-Free Service, Issue 2, May 1995.
- Bellcore GR-1429-CORE, Common Channel Signaling Network Interface Specification ("CCSNIS") Supporting Call Management Services, Issue 1, August 1994.
- Bellcore GR-1432-CORE, CCS Network Interface Specification ("CCSNIS") Supporting Signaling Connection Control Part ("SCCP") and Transaction Capabilities Application Part ("TCAP"), March 1994.
- Bellcore SR-TSV-002275, BOC Notes on the LEC Networks, Issue 2, April 1994.

AIN

- Bellcore GR-1280-CORE, Advanced Intelligent Network ("AIN") Service Control Point ("SCP") Generic Requirements, Issue 1, August 1993.
- Bellcore TR-NWT-001284, Advanced Intelligent Network ("AIN") 0.1 Switching System Generic Requirements, Issue 1, August 1992, and Bulletin 1, March 1993.
- Bellcore GR-1298-CORE, AINGR: Switching System, Issue 3, July 1996, and Revision 1, November 1996.
- Bellcore GR-1299-CORE, AINGR: Switch Service Control Point ("SCP") Adjunct Interface, Issue 3, July 1996, and revision 1, November 1996.
- Bellcore GR-2863-CORE, CCS Network Interface Specification Supporting Advanced Intelligent Network ("AIN"), Issue 2, December 1995.
- Bellcore GR-2902-CORE, CCS Network Interface Specification ("CCSNIS") Supporting Toll-Free Service Using AIN, Issue 1, May 1995.

- ANSI T1.101-1994, American National Standard for Telecommunications - Synchronization Interface Standard Performance and Availability.
- ANSI T1.102-1993, American National Standard for Telecommunications - Digital Hierarchy - Electrical Interfaces.
- ANSI T1.105-1995, American National Standard for Telecommunications - Synchronous Optical Network ("SONET") - Basic Description including Multiplex Structure, Rates and Formats.
- ANSI T1.105.01-1995, American National Standard for Telecommunications - Synchronous Optical Network ("SONET") - Automatic Protection Switching.
- ANSI T1.105.02-1995, American National Standard for Telecommunications - Synchronous Optical Network ("SONET") - Payload Mappings.
- ANSI T1.105.03-1994, American National Standard for Telecommunications - Synchronous Optical Network ("SONET") - Jitter at Network Interfaces.
- ANSI T1.105.03a-1995, American National Standard for Telecommunications - Synchronous Optical Network ("SONET"): Jitter at Network Interfaces - DSI Supplement.
- ANSI T1.105.04-1995, American National Standard for Telecommunications - Synchronous Optical Network ("SONET") - Data Communication Channel Protocols and Architectures.
- ANSI T1.105.05-1994, American National Standard for Telecommunications - Synchronous Optical Network ("SONET") - Tandem Connection.
- ANSI T1.105.06-1996, American National Standard for Telecommunications - Synchronous Optical Network ("SONET") - Physical Layer Specifications.
- ANSI T1.106-1988, American National Standard for Telecommunications - Digital Hierarchy - Optical Interface Specifications (Single Mode).
- ANSI T1.107-1988, American National Standard for Telecommunications - Digital Hierarchy - Formats Specifications.
- ANSI T1.107a-1990, American National Standard for Telecommunications - Digital Hierarchy - Supplement to Formats Specifications (DS3 Format Applications).
- ANSI T1.107b-1991, American National Standard for Telecommunications - Digital Hierarchy - Supplement to Formats Specifications.
- ANSI T1.117-1991, American National Standard for Telecommunications - Digital Hierarchy - Optical Interface Specifications ("SONET") (Single Mode - Short Reach).
- ANSI T1.119-1994, American National Standard for Telecommunications - Synchronous Optical Network ("SONET") - Operations, Administration, Maintenance, and Provisioning ("OAM&P") Communications.
- ANSI T1.119.01-1995, American National Standard for Telecommunications - Synchronous Optical Network ("SONET") - Operations, Administration, Maintenance, and Provisioning ("OAM&P") Communications Protection Switching Fragment.
- ANSI T1.231-1993, American National Standard for Telecommunications - Digital Hierarchy - Layer 1 In-Service Digital Transmission performance monitoring.

ANSI T1.404-1994, Network-to-Customer Installation - DS3 Metallic Interface Specification.

Bellcore GR-253-CORE, Synchronous Optical Network ("SONET"): Common Generic Criteria, Issue 2, December 1995.

Bellcore GR-334-CORE, Switched Access Service: Transmission Parameter Limits and Interface Combinations, Issue 1, June 1994.

Bellcore GR-342-CORE, High-Capacity Digital Special Access Service-Transmission Parameter Limits and Interface Combinations, Issue 1, December 1995.

Bellcore GR-499-CORE, Transport Systems Generic Requirements ("TSGR"): Common Requirements, Issue 1, December 1995.

Bellcore TR-NWT-000776, Network Interface Description for ISDN-1 Customer Access, Issue 2, February 1993.

Bellcore GR-820-CORE, OTGR Section 5.1: Generic Transmission Surveillance, Issue 1, November 1994.

Network Interface Device

--Bellcore GR-49-CORE, Generic Requirements for Outdoor Telephone Network Interface Devices, Issue 1, December 1994.

Bellcore TA-TSY-000120, Customer Premises or Network Ground Wire, Issue 1, March 1986.

Bellcore TR-NWT-000239, Generic Requirements for Indoor Telephone Network Interfaces, Issue 2, December 1993.

Bellcore TR-NWT-000937, Generic Requirements for Building Entrance Terminals, Issue 1, January 1993.

Collocation

ANSI/NFPA-1996, National Electrical Code ("NEC"), and any standard imposed by the appropriate governing authority having jurisdiction.

ANSI C2-1997, National Electrical Safety Code.

Bellcore GR-63-CORE, Network Equipment-Building System ("NEBS") Requirements: Physical Protection, Issue 1, October 1995.

Bellcore TR-EOP-000151, Generic Requirements for 24-, 48-, 130- and 140- Volt Central Office Power Plant Rectifiers, Issue 1, May 1985.

Bellcore TR-NWT-000154, General Requirements for 24-, 48-, 130-, and 140- Volt Central Office Power Plant Control and Distribution Equipment, Issue 2, January 1992.

Bellcore TR-NWT-000295, Isolated Ground Planes: Definition and Application to Telephone Central Offices, Issue 2, July 1992.

Bellcore TR-NWT-000840, Supplier Support Generic Requirements ("SSGR"), (A Module of LSSGR, FR-NWT-000064), Issue 1, December 1991.

PART B -- DEFINITIONS

"911 Service" or "911" means a universal telephone number which gives the public direct access to the Public Safety Answering Point (PSAP). Basic 911 service collects 911 calls from one or more local exchange switches that serve a geographic area. The calls are then sent to the correct authority designated to receive such calls.

"Access Service Request" (ASR) means the industry standard forms and supporting documentation used for ordering Access Services. The ASR may be used to order trunking and facilities between MCI and Bell Atlantic for local interconnection.

"Access Services" refers to interstate and intrastate switched access and private line transport services.

"Act" means the Communications Act of 1934, as amended.

"Adjunct Equipment" is peripheral equipment housing a database that interfaces with a switch and provides the switch with call processing instructions.

"Advanced Intelligent Network" (AIN) is a network functionality that permits specific conditions to be programmed into a switch which, when met, directs the switch to suspend call processing and to receive special instructions for further call handling in order to enable carriers to offer advanced features and services.

"Affiliate" is an entity that directly or indirectly owns or controls, is owned or controlled by, or is under common ownership or control with, another entity. In this paragraph, "own" means to own an equity interest (or equivalent) of more than ten percent (10%), and "control" means the right to control the business decisions, management and policy of another entity.

"Applicable Law" means all applicable laws and government regulations and orders, including, but not limited to, the regulations and orders of the Federal Communications Commission and the Commission.

"Automated Message Accounting" (AMA) means the structure inherent in switch technology that initially records telecommunication message information. AMA format is contained in the Automated Message Accounting document, published by Bellcore as GR-1100-CORE, which defines the industry standard for message recording.

"Automatic Location Identification" (ALI) is a proprietary database developed for E911 systems that provides for a visual display of the caller's telephone number, address and the names of the emergency response agencies that are responsible for that address. MCI will provide ALI record information in National Emergency Number Association (NENA) Version #2 format. The ALI also shows an Interim Number Portability (INP) number, if applicable.

"Automatic Location Identification/Data Management System" (ALI/DMS) means the emergency service (E911/911) database containing subscriber location information (including name, address, telephone number, and sometimes special information from the local service provider) used to determine to which PSAP to route the call.

"Automatic Number Identification" (ANI) is a feature that identifies and displays the number of a telephone that originates a call.

"Automatic Route Selection" (ARS) is a CENTREX service feature that provides for automatic selection of the least expensive or most appropriate toll transmission facility for each call based on criteria programmed into the system.

"Bell Atlantic" means Bell Atlantic - Pennsylvania, Inc.

"Bona Fide Request" shall have the meaning set forth in Part A, Section 25.

"CAP" means a competitive access provider.

"CLEC" means a competitive local exchange carrier.

"Calling Party Number" (CPN) is a CCS parameter which refers to the number transmitted through the network identifying the calling party.

"Carrier Access Billing System" (CABS) is defined in a document prepared under the direction of the Billing Committee of the OBF. The Carrier Access Billing System document is published by Bellcore in Volumes 1, 1A, 2, 3, 3A, 4 and 5 as Special Reports SR-OPT-001868, SR-OPT-001869, SR-OPT-001871, SR-OPT-001872, SR-OPT-001873, SR-OPT-001874, and SR-OPT-001875, respectively, and contains the recommended guidelines for the billing of access and other connectivity services.

"Central Office" or "Central Office Switch" means a switching entity within the public switched network, including, but not limited to, End Office Switches and Tandem Office Switches. Central Office Switches may be employed as combination End Office/Tandem Office Switches (Combination Class 5/Class 4).

"CENTREX" means a Telecommunications Service that uses Central Office switching equipment for call routing to handle direct-dialing of calls, and to provide numerous private branch exchange-like features.

"Charge Number" is a CCS parameter which refers to the number transmitted through the network identifying the billing number of the calling party.

"CLASS" (Bellcore Service Mark) -- Set of call-management service features that utilize the capability to forward a calling party's number between end offices as part of call setup. Features include automatic callback, automatic recall, caller ID, call trace, and distinctive ringing.

"Collocation" means the right of MCI to place equipment as specified in Attachment V in Bell Atlantic's Central Offices, or other Bell Atlantic locations pursuant to a Bona Fide Request. MCI equipment may be placed via either a physical or virtual collocation arrangement. With physical collocation, MCI obtains dedicated space to place and maintain its equipment. With virtual collocation, Bell Atlantic will install and maintain equipment that MCI provides to Bell Atlantic.

"Combinations" means provision by Bell Atlantic of two or more connected Network Elements ordered by MCI to provide its Telecommunication Services in a geographic area or to a specific subscriber and that are placed on the same order by MCI.

"Commission" means the Pennsylvania Public Utility Commission.

"Common Channel Signaling" (CCS) means a method of digitally transmitting call set-up and network control data over a digital signaling network fully separate from the public switched telephone network that carries the actual call.

"Common Transport" is as defined in Attachment III, Section 9.

"Conduit" means a tube or protected pathway that may be used to house communication or electrical cables. Conduit may be underground or above ground (for example, inside buildings) and may contain one or more inner ducts.

"Confidential Information" has the meaning set forth in Section 22 (Confidentiality) of Part A.

"Control Office" is an exchange carrier center or office designated as its company's single point of contact for the provisioning and maintenance of its portion of local interconnection arrangements.

"Dedicated Transport" is as defined in Attachment III, Section 10.

"Directory Assistance" (DA) or "Directory Assistance Services" provides Directory Listings to callers. Directory Assistance Services may include the option to complete the call at the caller's direction.

"Directory Assistance Database" refers to the database containing subscriber records that is used by Bell Atlantic in its provision of live or automated operator-assisted directory assistance including 411, 555-1212, NPA-555-1212.

"Directory Listings" (DL) refers to subscriber information, including name, address and phone numbers, that is published in any media, including traditional white/yellow page directories, specialty directories, CD ROM, and other electronic formats.

"Discloser" means that Party which has disclosed Confidential Information to the other Party.

"Effective Date" is the date indicated in Part A on which the Agreement shall become effective.

"End Office Switch" or "End Office" is a Central Office Switch (Class 5) used to connect subscriber station loops for the purpose of connecting to each other and to trunks.

"Enhanced 911 Service" (E911) means a telephone communication service which will automatically route a call dialed "911" to a designated PSAP attendant and will provide to the attendant the calling party's telephone number and, when possible, the address from which the call is being placed and the emergency response agencies responsible for the location from which the call was dialed.

"Exchange Access" means the offering of access to Telephone Exchange Services or facilities for the purpose of the origination or termination of telephone toll services.

"Exchange Message Record System" (EMR) means the system used among ILECs for exchanging telecommunications message information for billable, non-billable, sample, settlement and study data. EMR format is contained in BR-010-200-010 CRIS Exchange Message Record, published by Bellcore and which defines the industry standard for exchange message records.

"FOC" means firm order confirmation.

"ITC" means an independent telephone company.

"Including" means "including, but not limited to."

"Interconnection Point" (IP) is as defined in Attachment IV.

"Interim Number Portability" (INP) is an interim service arrangement whereby subscribers who change local service providers may retain existing telephone numbers without impairment of quality, reliability, or convenience when remaining at their current location or changing their location within the geographic area served by the initial carrier's serving End Office Switch. INP is provided by the means identified in Attachment VII, Section 2.

"Interexchange Carrier" (IXC) means a provider of interexchange Telecommunications Services.

"Line Information Database" (LIDB) is a SCP database that provides for such functions as calling card validation for telephone line number cards issued by ILECs and other entities and validation for collect and billed-to-third services.

"Line Status Verification/Verification and Call Interrupt" (LSV/VCI) means an operator-to-operator call in which the originating operator, on behalf of an end user, inquires as to the busy status of, or requests an interruption of, a call on a Telephone Exchange Service.

"Local Interconnection" is the interconnection of the networks of the Parties for the exchange of Local Traffic and other traffic, in accordance with the requirements of 47 U.S.C. Section 251, and other Applicable Law.

"Local Resale" is as defined in Attachment II.

"Local Switching" is as defined in Attachment III, Section 7.

"Local Traffic" means traffic that is originated by an end user subscriber of one Party on that Party's network and terminates to an end user subscriber of the other Party on that other Party's network within a given local calling area, or expanded area service ("EAS") area, as defined in Bell Atlantic's Tariffs, or, if the Commission has defined local calling areas applicable to all Local Exchange Carriers, then as so defined by the Commission.

"MCI_m" means MCI_mmetro Access Transmission Services LLC.

"Master Street Address Guide" (MSAG) is a database defining the geographic area of an E911 service. It includes an alphabetical list of the street names, high-low house number ranges, community names, and emergency service numbers provided by the counties or their agents to Bell Atlantic.

"Multiple Exchange Carrier Access Billing" (MECAB) refers to the document prepared by the Billing Committee of the OBF, which functions under the auspices of the Carrier Liaison Committee (CLC) of the Alliance for Telecommunications Industry Solutions (ATIS). The MECAB document, published by Bellcore as Special Report SR-BDS-000983, contains the recommended guidelines for the billing of an access service provided by two or more LECs (including a LEC and a CLEC), or by one LEC in two or more states within a single LATA.

"Multiple Exchange Carriers Ordering and Design" (MECOD) refers to the guidelines for Access Services - Industry Support Interface, a document developed by the Ordering/Provisioning Committee under the auspices of the OBF, which functions under the auspices of the Carrier Liaison Committee (CLC) of the Alliance for Telecommunications Industry Solutions (ATIS). The MECOD document, published by Bellcore as Special Report SR STS-002643, establishes recommended guidelines for processing orders for access service which is to be provided by two or more LECs (including a LEC and a CLEC). It is published by Bellcore as SRBDS 00983.

"National Emergency Number Association" (NENA) is an association with a mission to foster the technological advancement, availability and implementation of 911 nationwide.

"Network Element" means a facility or equipment used in the provision of a Telecommunications Service, including features, functions and capabilities that are provided by means of such facility or equipment.

"Network Interface Device" (NID) is as defined in Attachment III, Section 5.

"Network Rate Demarcation Point" shall have the same meaning as "demarcation point" in 47 C.F.R. § 68.3.

"Non-Discriminatory" or "Non-Discriminatory Basis" means that the Party shall perform the obligation or provide the service in question on a non-discriminatory basis for all other Telecommunications Carriers as defined in Section 202(a) of the Act, and/or Section 251 of the Act as applicable.

"North American Numbering Plan" (NANP) means the system or method of telephone numbering employed in the United States, Canada, and certain Caribbean countries. It denotes the three digit Numbering Plan Area code and a seven digit telephone number made up of a three digit Central Office code plus a four digit station number.

"Number Portability" (NP) is a long-term service arrangement whereby users of Telecommunications Services may retain, at the same location, existing Telecommunications numbers without impairment of quality, reliability, or convenience when switching from one Telecommunications Carrier to another.

"Numbering Plan Area" (NPA) (sometimes referred to as an area code) is the three digit indicator which is designated by the first three digits of each 10-digit telephone number within the NANP. Each NPA contains 800 possible NXX Codes. There are two general categories of NPA, "Geographic NPAs" and "Non-Geographic NPAs." A "Geographic NPA" is associated with a defined geographic area, and all telephone numbers bearing such NPA are associated with services provided within that Geographic area. A "Non-Geographic NPA," also known as a "Service Access Code (SAC Code)" is typically associated with a specialized telecommunications service which may be provided across multiple geographic NPA areas; 500, 800, 900, 700, and 888 are examples of Non-Geographic NPAs.

"NXX" or "NXX Code" is the three digit switch entity indicator which is defined by the fourth, fifth and sixth digits of a 10-digit telephone number within the NANP.

"OCN" means operating company number.

"Operator Services" provides (1) operator handling for call completion (e.g., collect calls); (2) operator or automated assistance for billing after the subscriber has dialed the called number (e.g., credit card calls); and (3) special services (e.g., LSV/VCI, Emergency Agency Call).

"Operator Systems" is the Network Element that provides operator and automated call handling with billing, special services, subscriber telephone listings, and optional call completion services.

"Ordering and Billing Forum" (OBF) means the entity which functions under the auspices of the Carrier Liaison Committee (CLC) of the Alliance for Telecommunications Industry Solutions (ATIS).

"Parity" means the following: (i) with respect to a performance requirement for interconnection, that Bell Atlantic will provide interconnection at a level of quality that is equal to that which it provides itself, a subsidiary, an Affiliate, or any other party; (ii) with respect to Local Resale, Bell Atlantic must provide services for resale that are equal in quality, subject to the same conditions, and provided with the same provisioning time intervals that Bell Atlantic provides these services to others, including end users; (iii) with respect to a performance requirement for the provision of a Network Element, that the quality of a Network Element, as well as the quality of the access to such Network Element be the same in quality that Bell Atlantic provides for all Telecommunications Carriers requesting access to that Network Element, and to the extent technically feasible, the quality of a Network Element, as well as the quality of the access to such Network Element, be at least equal in quality to that which Bell Atlantic provides to itself; and (iv) with respect to operational support systems (OSS), Bell Atlantic shall furnish Non-Discriminatory access to OSS functions, and provide access to OSS via electronic interfaces equivalent to that electronic access that Bell Atlantic provides to itself, its Affiliates and its subscribers.

"Party" means a party to this Agreement, either Bell Atlantic or MCI.

"Percent Interstate Usage" (PIU) is a calculation which represents the ratio of the interstate toll minutes to the sum of interstate and intrastate toll minutes between exchange carriers sent over Local Interconnection Trunks.

"Percent Local Usage" (PLU) is a calculation which represents the ratio of the Local Traffic minutes to the sum of Local Traffic and intrastate toll minutes between exchange carriers sent over Local Interconnection Trunks. Directory Assistance, LSV/VCI, 900, 975, transiting calls from other carriers and switched access calls are not included in the calculation of PLU.

"Point of Interconnection" (POI) is as defined in Attachment IV.

"Proprietary Information" shall have the same meaning as Confidential Information.

"Public Safety Answering Point" (PSAP) is the public safety communications center where 911 calls placed by the public for a specific geographic area will be answered.

"RAO" means revenue accounting office.

"Rate Center" means the geographic point and corresponding geographic area which are associated with one or more particular NPA-NXX codes which have been assigned to Bell Atlantic (or MCI) for its provision of Telephone Exchange Service. The "Rate Center point" is the finite geographic point identified by a specific V&H coordinate, which is used to measure distance-sensitive end user traffic to/from the particular NPA-NXX designations associated with the specific Rate Center. The "Rate Center area" is the exclusive geographic area identified as the area within which Bell Atlantic (or MCI) will provide Telephone Exchange Services bearing the particular NPA-NXX designations associated with the specific Rate Center. The Rate Center point must be located within the Rate Center area.

"Recipient" means that Party to this Agreement (a) to which Confidential Information has been disclosed by the other Party or (b) who has obtained Confidential Information in the course of providing services under this Agreement.

"Reciprocal Compensation" refers to a reciprocal compensation arrangement between two carriers in which each of the two carriers receives compensation from the other carrier for the transport and termination on each carrier's network facilities of Local Traffic that originates on the network facilities of the other carrier.

"Remote Switching Module" (RSM) is a switch with the limited capability of switching calls that can be completed between two (2) customers who are each served by unbundled local loops that are provided through the same RSM, *i.e.*, line-to-line switching. A call between a customer who is served by the RSM and a customer who is not served by the RSM must be sent to the host switch.

"Reseller" is a category of local exchange service providers who obtain dial tone and associated Telecommunications Services from another provider through the purchase wholesale priced services for resale to their end user subscribers.

"Right of Way" (ROW) means the right to use the land or other property of another party to place poles, conduits, cables, other structures and equipment, or to provide passage to access such structures and equipment. A ROW may run under, on, or above public or private property (including air space above public or private property) and may include the right to use discrete space in buildings, building complexes or other locations, but does not include inside wire space or structures past the network demarcation point.

"STP" means signaling transfer point.

"Selective Routing" is a service which automatically routes an E911 call to the PSAP that has jurisdictional responsibility for the service address of the telephone that dialed 911, irrespective of telephone company exchange or Wire Center boundaries.

"Service Area Concept" (SAC) is the box where Bell Atlantic cross-connects the Loop Feeder and the Loop Distribution.

"Service Control Point" (SCP) is as defined in Attachment III, Section 13.

"Small Exchange Carrier Access Billing" (SECAB) means the document prepared by the Billing Committee of the OBF. The Small Exchange Carrier Access Billing document, published by Bellcore as Special Report SR OPT-001856, contains the recommended guidelines for the billing of access and other connectivity services.

"Specialized Routing" is as defined in Attachment III, Section 7.2.2.

"Specialized Routing Node" is device that, based on the incoming ANI and the called number, will determine the proper routing for the call and either switch the call to the appropriate Bell Atlantic Operator Services platform or to a designated Point of Interconnection in the originating LATA.

"State" means the Commonwealth of Pennsylvania.

"Switch" - See Central Office Switch.

"Tandem Office Switches" are Class 4 switches, which are used to connect and switch trunk circuits between and among End Office switches and other tandems.

"Tandem Switching" is as defined in Attachment III, Section 14.

"Tariff" means any generally available schedule of terms, conditions, prices and fees by which Bell Atlantic or MCIm offers Telecommunication Services for sale to individuals, including subscriber agreements, special offerings and the like.

"Technically Feasible" is as defined in the FCC Interconnection Order. Interconnection, access to unbundled Network Elements, Collocation, and other methods of achieving interconnection or access to unbundled Network Elements at a point in the network shall be deemed technically feasible absent technical or operational concerns that prevent the fulfillment of a request by a Telecommunications Carrier for such interconnection, access, or methods. A determination of technical feasibility does not include consideration of economic, accounting, billing, space, or site concerns, except that space and site concerns may be considered in circumstances where there is no possibility of expanding the space available. The fact that an ILEC must modify its facilities or equipment to respond to such request does not determine whether satisfying such request is technically feasible. An ILEC that claims that it cannot satisfy such request because of adverse network reliability impacts must prove to the state commission by clear and convincing evidence that such interconnection, access, or methods would result in specific and significant adverse network reliability impacts.

"Telecommunications" means the transmission, between or among points specified by the user, of information of the user's choosing, without change in the form or content of the information as sent and received.

"Telecommunications Carrier" means any provider of Telecommunications Services, except that such term does not include aggregators of Telecommunications Services (as defined in Section 226 of the Act). A Telecommunications Carrier shall be treated as a common carrier only to the extent that it is engaged in providing Telecommunications Services, except that the Commission shall determine whether the provision of fixed and mobile satellite service shall be treated as common carriage. This definition includes Commercial Mobile Radio Service providers, IXCs and, to the extent they are acting as Telecommunications Carriers, companies that provide both Telecommunications and information services. Private mobile radio service providers are

Telecommunications Carriers to the extent they provide domestic or international Telecommunications for a fee directly to the public.

"Telecommunications Service" means the offering of telecommunications for a fee directly to the public, or to such classes of users as to be effectively available directly to the public, regardless of the facilities used.

"Telephone Exchange Service" means (a) service within a telephone exchange, or within a connected system of telephone exchanges within the same exchange area operated to furnish to subscribers intercommunicating service of the character ordinarily furnished by a single exchange, and which is covered by the exchange service charge, or (b) comparable service provided through a system of Switches, transmission equipment, or other facilities (or combination thereof) by which a subscriber can originate and terminate a Telecommunications Service.

"Unbundled Local Loop" (ULL) is as defined in Attachment III, Section 4.

"Voluntary Federal Subscriber Financial Assistance Programs" are Telecommunications Services provided to low-income subscribers, pursuant to requirements established by the appropriate state regulatory body.

"Wire Center" denotes a building or space within a building which serves as an aggregation point on a given carrier's network, where transmission facilities and circuits are connected or switched. Wire Center can also denote a building in which one or more Central Offices, used for the provision of Telephone Exchange Services and exchange Access Services, are located. However, for purposes of collocation service, Wire Center shall mean those points eligible for such connections as specified in the FCC Docket No. 91-141, and rules adopted pursuant thereto.

TABLE OF CONTENTS

Attachment I PRICE SCHEDULE

| | |
|--|-----|
| Section 1. General Principles | I-1 |
| Section 2. Network Elements and Call Transport and Termination | I-2 |
| Section 3. Local Service Resale | I-2 |
| Section 4. Interconnection and Reciprocal Compensation | I-2 |
| Section 5. Network Elements | I-4 |

ATTACHMENT I

PRICE SCHEDULE

Section 1. General Principles

1.1 Subject to Part A, Section 2, all rates and discounts provided under this Agreement shall remain in effect for the term of this Agreement unless modified by order of the FCC or Commission as the case may be, unless otherwise provided herein. The rates and discounts set by the Commission are permanent rates; however, such rates are not set in perpetuity and may be subject to re-examination and investigation by the Commission pursuant to its Final Opinion and Order in the MFS - Phase III Proceeding. To the extent that the rates set forth in Table 1 below reference existing Bell Atlantic or MCIm Tariffs, those rates shall follow the referenced Tariffs for the term of the Agreement. The rates or discounts set forth in Table 1 below may be subject to change and shall be replaced on a prospective basis (unless otherwise ordered by the FCC, the Commission, or the reviewing court(s)) by such revised rates or discounts as may be ordered approved, or permitted to go into effect by the FCC, the Commission, or a court of applicable jurisdiction, as the case may be. Such new rates or discounts shall be effective immediately upon the legal effectiveness of the court, FCC, or Commission order requiring such new rates or discounts. Within ten (10) days after the legal effectiveness of the court, FCC, or Commission order establishing such new rates or discounts and regardless of any intention by any entity to further challenge such order, the Parties shall sign a document revising Table 1 and setting forth such new rates or discounts, which revised Table 1 the Parties shall update as necessary in accordance with the terms of this Section.

1.2 Rates for Exchange Access Services purchased by either Party for use in the provision of toll service to end user customers are not affected by this Agreement.

1.3 Unless otherwise agreed, MCIim shall pay only the rates set forth in Table 1 for the services it purchases under this Agreement. Bell Atlantic shall pay for all of the development, modification, technical installation and maintenance of any systems or other infrastructure which it requires to provide the services set forth in this Agreement and priced in Table 1, and shall recover all such costs through the rates set forth in Table 1. Rates for services not yet identified in Table 1, but subsequently developed pursuant to the Bona Fide Request process or services identified in Table 1, but modified by regulatory requirements, shall be added as revisions to Table 1 when agreed between the Parties.

Section 2. Network Elements and Call Transport and Termination

2.1 On the Effective Date, the rates and discounts listed in Table 1 below, including those for: (i) Network Elements; and (ii) call transport and/or termination for Local Traffic purchased for the provision of Telephone Exchange Service or Exchange Access Service, are permanent rates, except as specifically noted herein or in Table 1. These rates may be changed as set forth in Section 1 of this Attachment I.

Section 3. Local Service Resale

3.1 The rates that MCI shall pay to Bell Atlantic for Local Resale shall be an amount equal to Tariff rates for each retail Telecommunications Service subject to wholesale pricing, as reduced by the applicable percentage discount set forth in Table 1, if such services are tariffed by Bell Atlantic for sale to subscribers who are not "Telecommunications Carriers" under the Act. If Bell Atlantic revises such tariffed rates during the term of this Agreement, the applicable percentage discount shall be applied to the revised tariffed rates. Unless otherwise specifically agreed between the Parties, no discount shall apply to Bell Atlantic Telecommunications Services that are tariffed by Bell Atlantic for sale to subscribers who are "Telecommunications Carriers" under the Act, which shall be available for resale, or to any Bell Atlantic services other than Telecommunications Services that it may, in its sole discretion, choose to offer for resale.

Section 4. Interconnection and Reciprocal Compensation

4.1 MCI may choose to deliver both Local Traffic and toll traffic over the same trunk group(s), pursuant to the provisions of Attachment IV. In the event MCI chooses to deliver both types of traffic over the same traffic exchange trunks, and desires application of the local call transport and termination rates, it will provide Percent Local Usage ("PLU") information to Bell Atlantic as set forth in Attachment IV. In the event MCI includes both interstate and intrastate toll traffic over the same trunk, it will provide Percent Interstate Usage ("PIU") to Bell Atlantic as set forth in Attachment IV. Bell Atlantic shall have the same options, and to the extent it avails itself of them, the same obligation, to provide PIU and PLU information to MCI. To the extent feasible, PLU and PIU information shall be based on the actual end-to-end jurisdictional nature of each call sent over the trunk. If actual PLU and PIU information cannot reasonably be determined, then the reporting Party shall estimate PLU and PIU, and, upon demand, explain the basis for the estimate. The basis for the PLU and PIU are subject to audits in accordance with the provisions of Part A.

4.2 Reciprocal Compensation for the exchange of Local Traffic is set forth in Table 1 of this Attachment and shall be assessed on a per minute-of-use basis for the transport and termination of such traffic.

4.3 MCIIm may choose to establish trunking to any given End Office for calls to numbers served out of that End Office, when there is sufficient traffic to route calls directly to such End Office. If MCIIm leases non-shared trunks from Bell Atlantic, MCIIm will pay the transport charges for dedicated transport. For shared trunks the charges will be shared by both Parties in proportion to their respective use of the shared trunk facility.

4.4 When the Bell Atlantic Interconnection Point is at a Bell Atlantic Tandem Office Switch, MCIIm shall pay Bell Atlantic the rates for Tandem Switching, a transport rate and a termination rate as set forth in Table 1. When the Bell Atlantic Interconnection Point is at the Bell Atlantic End Office, for calls terminating to Bell Atlantic subscribers served out of the End Office to which the traffic is delivered, MCIIm will pay Bell Atlantic call termination compensation based on End Office termination only.

4.5 Bell Atlantic will pay MCIIm a termination rate for termination of traffic at an MCIIm switch based upon the average rate paid by MCIIm to Bell Atlantic during the prior calendar quarter for the termination of all calls (including both switching and transport).

4.6 Compensation for the termination of toll traffic and the origination of 800 traffic between the interconnecting Parties shall be based on the applicable exchange access charges in accordance with FCC Rules and Regulations.

4.7 Where a toll call is completed through one Party's INP arrangement (e.g., remote call forwarding, flexible DID, etc.) to the second Party's subscriber, the second Party shall be entitled to access charges applicable to the functions performed by the second Party in accordance with FCC Rules and Regulations and as set forth in Attachment VIII, Section 3. Until such time as such access traffic can be measured directly, this access charge pass-through shall be based upon reasonable estimates of the proportion of traffic subject to such pass-through.

4.8 MCIIm shall pay a transit rate as set forth in Table 1 of this Attachment when MCIIm uses a Bell Atlantic Tandem Office to terminate a call to a third party Telecommunications Carrier. Bell Atlantic shall pay MCIIm an equivalent transit rate when Bell Atlantic uses an MCIIm Tandem Office (or functional equivalent) to terminate a call to a third party Telecommunications Carrier.

4.9 Each Party shall exercise all reasonable efforts to enter into reciprocal local traffic exchange arrangements (either via written agreement or mutual tariffs) with

any wireless carrier, ITC, or other LEC or CLEC to which it sends, or from which it receives, local traffic that transits Bell Atlantic facilities over traffic exchange trunks. If Party A fails to enter into such an arrangement as quickly as commercially reasonable in a LATA and to provide written notification of such agreement, including the relevant rates therein, to Party B, but continues to utilize Party B's transit service for the exchange of local traffic with such wireless carrier, ITC, or other LEC or CLEC, Party A shall, in addition to paying the rate set forth in this Attachment I for said transit service, pay Party B any charges or costs such terminating third party carrier imposes or levies on Party B for the delivery or termination of such traffic, including any switched access charges, plus all reasonable expenses incurred by Party B in delivering or terminating such traffic and/or resulting from Party A's failure to secure said reciprocal local traffic exchange arrangement. The Parties will, upon request, provide each other with all reasonable cooperation and assistance in obtaining such arrangements. The Parties agree to work cooperatively in appropriate industry fora to promote the adoption of reasonable industry guidelines relating to transit traffic.

Section 5. Network Elements

The charges that MCI shall pay to Bell Atlantic for Network Elements are set forth in Table I of this Attachment I.

TABLE 1

BELL ATLANTIC-PENNSYLVANIA, INC. AND MCI_{IM}DETAILED SCHEDULE OF ITEMIZED CHARGES¹

A. Bell Atlantic Services, Facilities, and Arrangements:

| | <u>Bell Atlantic Service</u> | <u>Non-recurring</u> | <u>Recurring</u> |
|------|---|--|---|
| 1.a. | Entrance facilities, and transport per Section 4, as appropriate, for Interconnection at Bell Atlantic End Office, Tandem Office, Serving Wire Center, or other Point of Interconnection Channel Termination | DS-1: Initial Facility: \$668.37 Service Order: \$1.05 Add'l Facility (if purchased at the time of Initial Facility order): \$331.87 DS-3: Initial Facility: \$668.37 Service Order: \$1.05 Add'l Facility (if purchased at the time of Initial Facility order): \$331.87 | DS-1: \$180.59/facility/month DS-3: \$1059.65/facility/month |

¹ Unless a citation is provided to a generally applicable BA tariff, all listed rates and services available only to MCI_{IM} when purchasing these services for use in the provision of Telephone Exchange Service, and apply only to Local Traffic and local ancillary traffic, such as LSV/MCI, Directory Assistance, 911/E911, and Operator Services IntraLATA Call Completion. BA rates and services for use by MCI_{IM} in the carriage of Toll Traffic shall be subject to BA's tariffs for Exchange Access service. Adherence to these limitations is subject to a reasonable periodic audit by BA.

As applied to wholesale discount rates, unbundled Network Elements or call transport and/or termination of Local Traffic purchased for the provision of Telephone Exchange Service or Exchange Access, the rates and charges set forth in Table 1 shall apply until such time as they are replaced by new rates as may be approved or allowed into effect by the Commission from time to time pursuant to the FCC Regulations, subject to a stay or other order issued by any court of competent jurisdiction. At such time(s) as such new rates have been approved or allowed into effect by the Commission, the Parties shall amend Table 1 to reflect the new approved rates.

| | <u>Bell Atlantic Service</u> | <u>Non-recurring</u> | <u>Recurring</u> |
|------|---|--|--|
| | Voice Grade Channel Termination | 2-Wire: Initial Facility: \$497.06 Service Order: \$1.05 Add'l Facility (if purchased at the time of Initial Facility order): \$289.47 | 2-Wire: \$16.78/facility/month |
| | Multiplexing | 4-Wire: Initial Line Install: \$498.73 Service Order: \$1.05 Add'l Facility (if purchased at the time of Initial Facility order): \$290.02 | 4-Wire: \$33.76/facility/month |
| | | DS-3 to DS-1: Initial Line Install: \$548.06 Service Order: \$1.05 Add'l Facility (if purchased at the time of Initial Facility order): \$548.06 | DS-3 to DS-1: \$257.61/facility/month |
| | | DS-1 to Voice Grade: Initial Line Install: \$548.06 Service Order: \$1.05 Add'l Facility (if purchased at the time of Initial Facility order): \$548.06 | DS-1 to Voice Grade: \$77.83/facility/month |
| 1.b. | Collocation and related services for Interconnection at Bell Atlantic End Office, Tandem Office, or Serving Wire Center | Per interstate [Bell Atlantic FCC 1 sec. 19] expanded interconnection tariffs and any applicable charges for unbundled Network Elements per section 3.a. below. | |
| 1.c. | Tandem transit arrangements (for Interconnection between MCI and local carriers other than Bell Atlantic IXCs subtending/MPB arrangements excluded) | | |
| | Tandem Switching | Not Applicable | \$0.000836/mou |
| | Transport Fixed | Not Applicable | \$0.000152/mou |
| | Transport per mile | Not Applicable | \$0.000004/mile/mou |
| 1.d. | 911 Interconnection | Per 1.a., 1.b., and 1.c. above, as applicable, for entrance facility plus applicable transport, or Collocation Arrangement at 911 tandem | |
| 1.e. | Directory Assistance Interconnection | Per 7 below. | |

| | Bell Atlantic Service | Non-recurring | Recurring |
|-------------------|---|--|--|
| 1.f. | Operator Services (call completion) Interconnection | Per 7.c. below | |
| 2.a. ² | Poles | Application and Engineering Survey Fee: Actual Full Cost Recovery | Annual Fee: Per BA-PA Tariff 303 Section C Illustrative: Vertical Attachment \$3.98/attachment/year |
| 2.b. | Duct/Innerduct | Application and Engineering Survey Fee: Actual Full Cost Recovery | Annual Fee: As per BA-PA Tariff 303 Section C Illustrative: Per Duct run: \$5.45/foot/year per innerduct: \$3.25/foot/year |
| 2.c. | Conduits | Application and Engineering Survey Fee: Actual Full Cost Recovery | Annual Fee: As per BA-PA Tariff 303 Section C Illustrative: Conduit: \$5.45/foot/year |
| 2.d. | Right of Way | Application and Engineering Survey Fee: Right of Way (determined on a case-by-case basis) | Annual Fee: Right of Way (determined on a case-by-case basis as mutually agreed by the Parties) |
| 3.a. | Local loop transmission Unbundled Local Loop Element and cross-connect to Basic Links ¹ | | |

² The rates set forth in 2.a, 2.b, 2.c, and 2.d of this Table are subject to revision by the FCC and/or the Commission in accordance with Section 224 of the Act.

¹ Installation charges not applicable when MCI orders both loop and port elements together where BA does not perform an installation function.

| | <u>Bell Atlantic Service</u> | <u>Non-recurring</u> | <u>Recurring</u> |
|--|--|---|--|
| | 2 Wire Analog Loops (POTS Loops) and 2-Wire Customer-Specified Signaling | <p>Line Install, if premises visit not required: Initial loop: \$2.97 Each additional loop: \$2.97</p> <p>Service Order: \$1.05</p> <p>Line Install, if premises visit required: Initial loop: \$66.85 Each additional loop: \$22.59</p> <p>Disconnect: \$1.32/loop</p> <p>Coordinated Cut-Over (only applicable for 2-Wire Customer-Specified Signaling) If premises visit not required: \$3.24/order If premises visit required: \$12.10/order</p> <p>CSS Design (only applicable for 2-Wire Customer-Specified Signaling): \$40.93/order</p> | <p>Density Cell:⁴</p> <p>1 - \$11.52/loop/month 2 - \$12.71/loop/month 3 - \$16.12/loop/month 4 - \$23.11/loop/month</p> |
| | 4-Wire Customer-Specified Signaling | <p>Line Install, if premises visit not required: Initial loop: \$2.97 Each additional loop: \$2.97</p> <p>Service Order: \$1.05</p> <p>Install, if premises visit required: Initial loop: \$66.85 Each additional loop: \$22.59</p> <p>Disconnect: \$1.32/loop</p> <p>Coordinate Cut-Over If premises visit not required: \$3.24/order If premises visit required: \$12.10/order</p> <p>CSS Design: \$40.93/order</p> | <p>Density Cell:</p> <p>1 - \$22.40/month 2 - \$26.36/month 3 - \$33.03/month 4 - \$45.47/month</p> |

⁴ References to Density Cells in 3.2, as per BA-PA Tariffs I, Section 12A.4, 180A Paragraphs B.4 & B.5, and Paragraph E.2 of Tariffs 182, 182A, 185B, and 185C.

| | <u>Bell Atlantic Service</u> | <u>Non-recurring</u> | <u>Recurring</u> |
|--|-------------------------------|--|--|
| | ISDN Loops | <p>Line Install, if premises visit not required: Initial loop: \$12.91 Each additional loop: \$12.91</p> <p>Service Order: \$1.05</p> <p>Line Install, if premises visit required: Initial loop: \$76.78 Each additional loop: \$32.52</p> <p>Disconnect: \$1.32/loop</p> | <p>Density Cell: 1 - \$13.16/month 2 - \$14.35/month 3 - \$17.75/month 4 - \$24.74/month</p> |
| | DS-1 Loops | <p>Line Install, if premises visit not required: Initial loop: \$2.97 Each additional loop: \$2.97</p> <p>Service Order: \$1.05</p> <p>Line Install, if premises visit required: Initial loop: \$66.85 Each additional loop: \$22.59</p> <p>Disconnect: \$1.32/loop</p> <p>Coordinate Cut-Over If premises visit not required: \$3.24/order If premises visit required: \$12.10/order</p> <p>CSS Design: \$40.93/order</p> | <p>Density Cell: 1 - \$132.51/month 2 - \$139.37/month 3 - \$168.59/month 4 - \$252.45/month</p> |
| | 2-Wire ADSL Loops* | TBD | TBD |
| | 2-Wire and 4-wire HDSL Loops* | TBD | TBD |

* These rates are subject to approval by the Commission.

* These rates are subject to approval by the Commission.

| | <u>Bell Atlantic Service</u> | <u>Non-recurring</u> | <u>Recurring</u> |
|--|----------------------------------|--|--|
| | Collocation Cross-Connect System | | |
| | Voice Grade Loop Cross-Connect | Physical DS0: CO side to equipment: Not Applicable Virtual DS1 w/EDSX ¹ : Initial Line Install: \$544.36 Service Order: \$1.05 Add'l Line Install: \$210.46 Virtual DS1 w/CFA: Initial Line Install: \$544.36 Service Order: \$1.05 Add'l Line Install: \$210.46 Virtual DS0 w/RFT: Not Applicable | Physical DS0: CO side to equipment: \$0.41/month Virtual DS1 w/EDSX: \$60.21/month Virtual DS1 w/CFA: \$44.08/month Virtual DS0 w/RFT: \$1.20/month |
| | Other Cross-Connect | Physical DS3: Initial Line Install: \$481.36 Service Order: \$1.05 Add'l Line Install: \$194.71 Physical DS1: Initial Line Install: \$481.36 Service Order: \$1.05 Add'l Line Install: \$194.71 Virtual DS3: Initial Line Install: \$481.36 Service Order: \$1.05 Add'l Line Install: \$194.71 Virtual DS1: Initial Line Install: \$481.36 Service Order: \$1.05 Add'l Line Install: \$194.71 | Physical DS3: \$84.27/month Physical DS1: \$15.72/month Virtual DS3: \$88.81/month Virtual DS1: \$16.12/month |

A Virtual DS1 element with EDSX consists of one (1) DS1 plus twenty-four (24) DS0 with an IDLC.

| | <u>Bell Atlantic Service</u> | <u>Non-recurring</u> | <u>Recurring</u> |
|--------|---|---|--|
| | Digital Cross-Connect System | Service Establishment: \$1890.82 Database Modification: \$148.68/modification request Reconfiguration by BA Personnel: \$31.98/programming charge/30-minute increment DS0 Cross-Connect: \$26.17/port DS1 Cross-Connect: \$32.71/port | Not Applicable Not Applicable Not Applicable DS0 Cross-Connect: \$20.54/port/month DS1 Cross-Connect: \$71.92/port/month |
| 3.b. | Special Construction Charges | As applicable per Bell Atlantic-BA-PA PUC 1 sec. 9 | |
| 3.c.1. | Service Technician Charges (Maintenance Service Charges) (service technician work on unbundled loops outside of the central office) | Service Call-Dispatch and 15 min. labor: \$26.24/premise visit Labor: \$12.10/15-minute increment after first quarter hour Service Order: \$1.05 | Not Applicable |
| 3.c.2. | Central Office Technician Charges | Labor: \$10.42/15-minute increment or fraction thereof Service Order: \$1.05 | Not Applicable |
| 4.a. | Unbundled Dedicated Transport DS-1 | Initial Facility: \$353.70 Service Order: \$1.05 Add'l Facility (if purchased at time of Initial Facility): \$24.00 | \$37.66/facility/month \$0.66/facility/mile/month |
| 4.b. | Unbundled Dedicated Transport DS-3 | Initial Facility: \$353.70 Service Order: \$1.05 Add'l Facility (if purchased at time of Initial Facility): \$24.00 | \$526.72/facility/month \$18.66/facility/mile/month |
| 4.c. | Unbundled Dedicated Transport Voice Grade/DS-0 | Initial Facility: \$353.70 Service Order: \$1.05 Add'l Facility (if purchased at time of Initial Facility): \$24.00 | \$10.37/facility/month \$0.03/facility/mile/month |

| | <u>Bell Atlantic Service</u> | <u>Non-recurring</u> | <u>Recurring</u> |
|------|---|--|--|
| 4.d. | Unbundled Dedicated Transport DDS | Initial Facility: \$353.70 Service Order: \$1.05 Add'l Facility (if purchased at time of Initial Facility): \$24.00 | \$10.74/facility/month \$0.04/facility/mile/month |
| 4.e. | Mid-Span Meet Arrangements | On a case-by-case basis in accordance with Attachment IV. | |
| 4.f. | Common or Shared Transport Tandem Switching Transport Fixed Transport per mile | Not Applicable Not Applicable Not Applicable | \$0.000836/mou \$0.000152/mou \$0.000004/mile/mou |
| 5.a. | Local switching Unbundled Ports POTS/PBX/CENTREX ISDN PRI ISDN BRI Public/Semi-Public DID | Installation: \$2.97/port Service Order: \$1.05/port ¹ Disconnect: \$1.32/port Installation: \$113.36/port Service Order: \$1.05/port ⁹ Disconnect: \$1.32/port Installation: \$2.97/port Service Order: \$1.05/port ¹⁰ Disconnect: \$1.32/port Installation: \$2.97/port Service Order: \$1.05/port ¹¹ Disconnect: \$1.32/port Installation: \$692.07/port Service Order: \$1.05/port ¹² Disconnect: \$1.32/port | \$2.67/port/month \$135.13/port/month \$10.25/port/month \$3.52/port/month \$5.98/port/month |

¹ Not applicable when MCI orders both loop and switching elements together where Bell Atlantic does not perform an installation function.

| | <u>Bell Atlantic Service</u> | <u>Non-recurring</u> | <u>Recurring</u> |
|------|---|--|--|
| 5.b. | Local switching Unbundled Switching | Not Applicable | Originating (with Vertical Features): \$0.011067/mou Terminating (with Vertical Features): \$0.006143/mou |
| 5.c. | Tandem Switching | Not Applicable | \$0.0008360/mou, plus tandem switched transport as needed |
| 6. | Network Interface Device | Not Applicable | \$0.68/NID/month ¹³ |
| 7.a. | 911 service (data entry; database maintenance) | No charge | |
| 7.b. | Directory Assistance Data | Per Section 6.1.7 of Attachment VIII of this Agreement | Per Section 6.1.7 of Attachment VIII of this Agreement |
| 7.c. | Directory Assistance Services/Operator Services | | |
| | Directory Assistance Service | Not Applicable | \$0.3664/call |
| | Directory Transport ¹⁴ Tandem Switching | Not Applicable | \$0.000730/call |
| | Tandem Switched Transport | Not Applicable | \$0.000132/call and \$0.000003/mile/call |
| | Operator Services Live | Not Applicable | \$0.0128/operator work second |
| | Automated ¹⁴ | Not Applicable | \$0.00158/automated work second |
| | Branding ¹⁴ | \$1.358.62/branding message | Not Applicable |
| | Carrier-to-Carrier LSV/VCI Requests | Not Applicable | \$0.01280/operator work second |

* Not applicable when MCIm orders both loop and switching elements together where Bell Atlantic does not perform an installation function.

¹⁰ Not applicable when MCIm orders both loop and switching elements together where Bell Atlantic does not perform an installation function.

¹¹ Not applicable when MCIm orders both loop and switching elements together where Bell Atlantic does not perform an installation function.

¹² Not applicable when MCIm orders both loop and switching elements together where Bell Atlantic does not perform an installation function.

¹³ Not applicable when MCIm order a loop element.

¹⁴ These rates are interim rates until permanent rates are established by the Commission.

| | <u>Bell Atlantic Service</u> | <u>Non-recurring</u> | <u>Recurring</u> |
|-------|--|---|--|
| 8.a. | White Pages and Yellow Pages directory listings ¹⁷ | Not Applicable | Not Applicable |
| 8.b. | Books & delivery (annual home area directories only) | No charge for normal numbers of books delivered to end users; bulk deliveries to MCI _m per separate arrangement | |
| 8.c. | Additional listings, changes to listings, non-listed, non-published | Per tariff [Bell Atlantic-BA-PA PUC 1 sec. 5.B) less wholesale discount Illustrative (non-discounted rates): Additional listing: \$12.00 residence; \$15.00 (1 ^m), \$9.00 (additional) business Change to listing: \$12.00 residence; \$15.00 (1 ^m), \$9.00 (additional) business Non-list: \$15.00 residence or business Non-published: \$15.00 residence or business | Per tariff [Bell Atlantic-BA-PA PUC 1 sec. 5.B) less wholesale discount Illustrative (non-discounted rates): \$1.25/mo residence \$2.05/mo business \$1.25/mo residence or business \$1.75/mo residence or business |
| 9. | Access to telephone numbers (NXX codes issued per ICCF Code Administration Guidelines) | No Charge | |
| 10.a. | SS7 Interconnection | | |
| | STP Port - Termination: | \$94.15/port | \$640.02/port/month |
| | STP Port - Access: ¹⁸ | Service Order: \$1.05/order | \$0.47/mile/month |
| | | Initial Facility: \$274.06/facility Add'l Facility: \$24.01/facility | |

¹⁶ This rate is an interim rate until a permanent rate is established by the Commission.

¹⁶ This rate is an interim rate until a permanent rate is established by the Commission.

¹⁷ These listings refer to primary listings on initial UNE order or resale order. For each residence telephone number, two (2) listings in the White Page directory are provided. For each business telephone number listed (except numbers of CENTREX or CENTREX-like services or indialing service station lines) one (1) listing is provided in the White Page Directory and one (1) listing in the Yellow Page directory of the type provided to BA-PA end user business customers for which no specific charge applies.

¹⁸ These rates are interim rates until permanent rates are established by the Commission.

| | <u>Bell Atlantic Service</u> | <u>Non-recurring</u> | <u>Recurring</u> |
|-------|---|---|---|
| 10.b. | LIDB Interconnection LIDB Point Codes ¹⁹ Calling Card Billed Number Screening Storage of MCI's Data in LIDB Database ²⁰ | \$85.84/point code Not Applicable Not Applicable \$1,469.92/service establishment | Not Applicable \$0.015542/query \$0.015542/query Not Applicable |
| 10.c. | 800/888 data base Interconnection | Not Applicable | Basic Query: \$0.000835/query Vertical Query: \$0.000343/query |
| 11.a. | Interim Number Portability | "Track and True-up" - Once the Commission establishes a rate and cost recovery method, there will be a retroactive true-up with interest charges at the appropriate Commission-determined rate. | |
| 11.b. | Pass-through of access charges under INP arrangement | In accordance with Attachment VIII, Section 3.1.5 | |
| 12. | Local Dialing Parity | No Charge | |
| 13.a. | Reciprocal call termination Local traffic delivered to Bell Atlantic Interconnection Point | Not Applicable | Termination at BA Tandem: \$0.002902/mou Termination at End Office: \$0.001864/mou |
| 13.b. | Access charges for termination of intrastate and interstate toll traffic | Per Bell Atlantic's interstate and intrastate access tariffs (charged in conjunction with Local Traffic, using PLU and PIU, as appropriate) | |
| 14.a. | Local Resale ²¹ | Percentage discount from price in retail Tariff ²² | |

¹⁹ This rate is an interim rate until a permanent rate is established by the Commission.

²⁰ This rate is an interim rate until a permanent rate is established by the Commission.

²¹ The wholesale discounts for the resale of retail telecommunications services excludes Telecommunications Services designed primarily for wholesale, such as switched and special Exchange Access service, and, subject to Attachment II of the Agreement, the following additional arrangements that are not subject to resale: limited duration (90 days or less) promotional offerings, public coin telephone service, and technical and market trials. Taxes shall be collected and remitted by the reseller and BA in accordance with legal requirements and as agreed between the Parties. Surcharges (e.g., 911, telecommunications relay service, universal service fund) shall be collected by the reseller and either remitted to the recipient agency or NECA, or passed through to BA for remittance to the recipient agency or NECA, as appropriate and agreed between the Parties. End user common line charges shall be collected by the reseller and remitted to BA.

²² Pending establishment of mechanized billing procedures adapted to resale, BA will apply the wholesale discount for resale as a "bottom-of-the-bill" discount rate and will utilize a "true-up" process to correct possible

| | <u>Bell Atlantic Service</u> | <u>Non-recurring</u> | <u>Recurring</u> |
|---------|--|--|---|
| 14.b. | Resale of retail Telecommunications Services where MCI _m does not use Bell Atlantic's Operator Services | 20.69% | |
| 14.c. | Resale of retail Telecommunications Services where MCI _m uses Bell Atlantic's Operator Services | 18.43% | |
| 14.d. | Pennsylvania Gross Receipts Tax discount | Equal to Pennsylvania Gross Receipts Tax (currently 5%) in addition to 14.b or 14.c above | |
| 15.a. | Access to Pre-Ordering OSS | Not Applicable | \$0.22/query |
| 15.b. | Access to Ordering OSS | Not Applicable | \$3.34/transaction |
| 15.c. | Access to Provisioning OSS | Not Applicable | No Charge - Included in Ordering |
| 15.d. | Access to Maintenance & Repair OSS | Not Applicable | ECG Access: \$5.22/query EB/OSI Access: \$1.16/trouble ticket |
| 15.e.1. | Access to Billing OSS: CD-ROM | Not Applicable | \$246.59/CD-ROM |
| 15.e.2. | Access to Billing OSS: Daily Usage File Existing Message Recording Existing Message Recording | Not Applicable | \$0.000258/message |
| 15.e.3. | Access to Billing OSS: Daily Usage File Delivery Data Tape Network Data Mover CMDS | \$61.39/programming hour Not Applicable \$61.39/programming hour | \$17.18/tape \$0.000094/message \$0.000094/message |
| 15.e.4. | Access to Billing OSS: Daily Usage File Transport ²³ 9.6 kb Communications Port 56 kb Communications Port 256 kb Communications Port T1 Communications Port | Installation: \$7,437.36/port Installation: \$30,778.91/port Installation: \$51,236.88/port Installation: \$182,827.99/port | \$10.24/port/month \$28.29/port/month \$28.29/port/month \$359.31/port/month |

inadvertent application of the wholesale discount to the exclusions identified herein and to reflect other adjustments as the Companies agree.

²³ Not applicable to MCI_m if Network Data Mover connectivity has previously been established, and existing facilities are adequate to support transmission of Daily Usage File Data. If additional facilities are required to support transmission of Daily Usage File data, rates TBD.

| | Bell Atlantic Service | Non-recurring | Recurring |
|-----|--|---|---|
| | Line Installation | \$61.39/programming hour/port | Not Applicable |
| | Port Set-up | \$9.85/port | Not Applicable |
| | Network Control Programming Coding | \$61.39/programming hour/port | Not Applicable |
| 16. | Customized Routing | | |
| | To MCI _m Platform | \$3.84/line | \$0.142350/line/month |
| | To Bell Atlantic Platform for Re-Branding ^{**} | \$3.84/line | \$0.08330/call |
| | Customized Routing Transport | See sections 1 & 4 of Table 1 above. | See sections 1 & 4 of Table 1 above. |

^{**} These rates are interim rates until permanent rates are established by the Commission.

| | <u>Bell Atlantic Service</u> | <u>Non-recurring</u> | <u>Recurring</u> |
|-----|---|-------------------------------|----------------------|
| 17. | AIN Service Creation | | |
| | Developmental Charges Service Establishment: | \$884.08 | Not Applicable |
| | Service Creation Access Port: | Not Applicable | \$123.86/port/month |
| | Service Creation Usage Remote Access: | Not Applicable | \$1328.47/day |
| | On-Premise: | Not Applicable | \$1328.47/day |
| | Certification and Testing | Not Applicable | \$76.99/hour |
| | Help Desk Support | Not Applicable | \$81.48/hour |
| | Service Charges | | |
| | Subscription Charges: | Not Applicable | \$5.44/month |
| | Database Queries | | |
| | Network Query: | Not Applicable | \$0.0007/query |
| | MCI _m Network Query: | Not Applicable | \$0.0007/query |
| | MCI _m Switch Query: | Not Applicable | \$0.0007/query |
| | Trigger Charges | | |
| | Line-Based: | Not Applicable | \$0.0010/query |
| | Office-Based | Not Applicable | \$0.0010/query |
| | Utilization Element: | Not Applicable | \$0.0003/query |
| | Service Activation Charge | | |
| | Network Service Activation: | \$8.37/service activated/line | Not Applicable |
| | MCI _m Network Service Activation: | \$8.37/service activated/line | Not Applicable |
| | MCI _m Switch Service Activation: | \$8.37/service activated/line | Not Applicable |
| | Service Modification | | |
| | DTMF Update: | Not Applicable | \$0.1080/occurrence |
| | Switch-Based Announcement: | Not Applicable | \$0.005/announcement |

| | <u>Bell Atlantic Service</u> | <u>Non-recurring</u> | <u>Recurring</u> |
|-----|--|---|----------------------------|
| 18. | Rebundling of Unbundled Services | Pre-existing BA-PA end users: applicable port service order charge (see Section 5 above) Other end users: applicable service order charge for port and installation charges for loop and port (see Sections 3 and 5 above) | See Sections 3 and 5 above |
| 19. | Network Element: Recombination Service ²³ | TBD | TBD |

²³ These rates are subject to approval by the Commission.

B. MCI_m Services, Facilities, and Arrangements:

| | <u>MCI_m Service</u> | <u>Non-recurring</u> | <u>Recurring</u> |
|-----|--|---|--|
| 1.a | Interim Number Portability through co-carrier call forwarding | "Track and True-up" - Once the Commission establishes a rate and cost recovery method, there will be a retroactive true-up with interest charges at the appropriate Commission-determined rate. | |
| 1.b | Pass-through of access charges under INP arrangement | In accordance with Attachment VIII, Section 3.1.5. | |
| 2. | Local Dialing Parity | No charge | |
| 3.a | Reciprocal call termination Local Traffic delivered to MCI _m Interconnection Point | Not Applicable | Average rate paid by BA to MCI _m in the previous calendar quarter ²⁶ |
| 3.b | Access charges for termination of intrastate and interstate Toll Traffic | Per MCI _m 's interstate and intrastate access Tariffs (charged in conjunction with Local Traffic, using PLU and PIU, as appropriate) | |
| 4.a | Trunk Side transport for Local Interconnection DS-1 trunks | Same rates as set forth in 4.a of Part A. of this Table 1 as may be amended from time to time pursuant to footnote 1 above | |
| 4.b | Trunk Side transport for Local Interconnection DS-3 trunks | Same rates as set forth in 4.b of Part A. of this Table 1 as may be amended from time to time pursuant to footnote 1 above | |
| 5. | All other MCI _m services available to Bell Atlantic | Available at MCI _m 's tariffed or otherwise generally available rates or as agreed to by the Parties. | |

²⁶ MCI_m's rates for the termination of BA's Local Traffic shall be recalculated once each year on each anniversary of the Effective Date (the "Rate Determination Date"). The methodology for recalculating the rates is as follows:

Access Tandem Minutes = Total minutes of use of Local Traffic delivered by MCI_m to the BA Access Tandem for most recent billed quarter.

End Office Minutes = Total minutes of use Local Traffic delivered by MCI_m directly to the terminating BA End Office for most recent billed quarter.

Total Minutes = Total minutes of use of Local Traffic delivered by MCI_m to BA for most recent billed quarter.

MCI_m Charge at the MCI_m-IP =

$$\frac{(\text{Access Tandem Minutes} \times \text{BA Tandem Termination Rate } (\$0.002902)) - (\text{End Office Minutes} \times \text{BA End Office Termination Rate } (\$0.001864))}{\text{Total Minutes}}$$

Total Minutes

For the first year after the Effective Date, the MCI_m charge shall be calculated based on the traffic data of the quarter immediately preceding such Effective Date, or if no such traffic exists, on the proportion of local call termination trunks to BA End Offices and to BA Access Tandems.

| | <u>MCI_m Service</u> | <u>Non-recurring</u> | <u>Recurring</u> |
|----|---|---|------------------|
| 6. | Entrance facilities, and transport, as appropriate, for Local Interconnection at: MCI _m End Office/Tandem Office, Serving Wire Center, or other Point of Interconnection | Same rates as set forth in 1.a. of Part A of this Table 1 as may be amended from time to time pursuant to footnote 1 above) | |

TABLE OF CONTENTS

Attachment III NETWORK ELEMENTS

| | | |
|-------------|--|----------|
| Section 1. | Introduction | III - 1 |
| Section 2. | Unbundled Network Elements | III - 1 |
| Section 3. | Standards for Network Elements | III - 2 |
| Section 4. | Loop | III - 3 |
| Section 5. | Network Interface Device | III - 5 |
| Section 6. | Distribution | III - 7 |
| Section 7. | Local Switching | III - 7 |
| Section 8. | Operator Systems | III - 12 |
| Section 9. | Common Transport | III - 12 |
| Section 10. | Dedicated Transport | III - 13 |
| Section 11. | Signaling Link Transport | III - 16 |
| Section 12. | Signaling Transfer Points ("STPs") | III - 18 |
| Section 13. | Call Related Databases and AIN | III - 21 |
| Section 14. | Tandem Switching | III - 27 |
| Section 15. | Additional Requirements | III - 29 |
| Section 16. | Basic 911 and E911 | III - 35 |
| Section 17. | Directory Assistance Data | III - 35 |
| Exhibit A. | TR 72565 | |
| Exhibit B. | TR 72570 | |
| Exhibit C. | TR 72575 | |
| Exhibit D. | Specialized Routing Solution For Operator and DA Calls | |
| Exhibit E. | AIN Exception List | |
| Exhibit F. | TR 72580 | |
| Exhibit G. | TR 72585 | |
| Exhibit H. | IntraLATA Telecommunications Services Settlement | |

ATTACHMENT III

NETWORK ELEMENTS

Section 1. Introduction

1.1 Bell Atlantic shall provide unbundled Network Elements in accordance with this Agreement and Applicable Law. The price for each Network Element is set forth in Attachment I of this Agreement. Except as otherwise set forth in this Attachment, MCI may order Network Elements as of the Effective Date. The obligations set forth in this Attachment III shall apply to such Network Elements: (i) available when this Agreement becomes effective; (ii) that subsequently become available; and (iii) in all cases to those features, functions, combinations, and capabilities, the provision of which is Technically Feasible at such time as they are incorporated in unbundled Network Elements offered by Bell Atlantic.

Section 2. Unbundled Network Elements

2.1 Bell Atlantic shall offer Network Elements to MCI on an unbundled basis on rates, terms and conditions that are just, reasonable, and Non-Discriminatory in accordance with the terms and conditions of this Agreement.

2.2 Bell Atlantic shall permit MCI to connect MCI's facilities or facilities provided to MCI by third-parties with each of Bell Atlantic's unbundled Network Elements at those generic points within Bell Atlantic's network, designated within this Agreement or as a result of the Bona Fide Request ("BFR") process.

2.3 MCI may use one or more Network Elements to provide features, functions, or capabilities that such Network Element(s) provide as of the date hereof in Bell Atlantic's network, or as may otherwise be agreed upon through the BFR process.

2.3.1 MCI may, at its option, select methods of access to unbundled elements, as described in this Agreement, or as may otherwise be agreed upon through the BFR process.

2.4 Bell Atlantic shall offer each Network Element individually and in Combinations (where Technically Feasible), solely in order to permit MCI to provide Telecommunications Services to its subscribers.

2.5 For each Network Element, Bell Atlantic shall provide connectivity at a point which is agreeable to both Parties. However, where Bell Atlantic provides combined Network Elements at MCI's request, no connectivity point between the Parties shall exist between such contiguous Network Elements.

2.6 This Attachment describes the initial set of Network Elements which MCI and Bell Atlantic have identified as of the Effective Date of this Agreement:

- Loop
- Network Interface Device
- Local Switching
- Operator Systems
- Common Transport
- Dedicated Transport
- Signaling Link Transport
- Signaling Transfer Points
- Service Control Points/Databases
- Tandem Switching
- Directory Assistance

2.6.1 MCI and Bell Atlantic agree that the Network Elements identified in this Attachment may prove not to be all possible Network Elements.

2.6.2 MCI may identify additional or revised Network Elements as necessary to provide Telecommunications Services to its subscribers, to improve network or service efficiencies or to accommodate changing technologies, subscriber demand, or other requirements.

2.6.2.1 MCI will request any such Network Elements in accordance with the BFR process described in Section 25 (BFR Process for Further Unbundling) of Part A. Additionally, if Bell Atlantic provides any Network Element that is not identified in this Agreement to another CLEC pursuant to an approved Interconnection Agreement, Bell Atlantic shall make available the same Network Element to MCI under the same terms, and conditions, as required by 47 U.S.C. Section 252(i).

Section 3. Technical Standards and Technical Specifications for Network Elements

3.1 Each Network Element shall be furnished at the service levels included in this Agreement and in accordance with the performance standards required in this Agreement.

3.2 Each Network Element provided by Bell Atlantic to MCI, unless identified differently in this Agreement, shall be provided at Parity and in a Non-Discriminatory manner in the areas of: quality of design, performance, features, functions, capabilities and other characteristics, including but not limited to levels and types of redundant equipment and facilities for power, diversity and security, that Bell Atlantic provides to itself (where applicable and Technically Feasible), Bell Atlantic's own subscribers (where applicable and Technically Feasible), to a Bell Atlantic Affiliate, or to any other entity, as set forth in the FCC Rules and Regulations, as the same may be amended from time to time.

3.2.1 Bell Atlantic shall provide to MCI, upon reasonable request, reasonably available engineering, design, performance and other network data sufficient for MCI to determine that the requirements of this Section 3 are being met. In the event that such data indicates that the requirements of this Section 3 are not being met, the Parties shall in good faith endeavor to address the issue at the network operations supervisor level, and if necessary, employ the escalation procedure of Section 15.1.2.

3.2.2 Bell Atlantic agrees to work cooperatively with MCI to ensure that the Network Elements that are provided pursuant to this Agreement will meet MCI's reasonable needs in providing services to its subscribers.

3.3 Unless otherwise requested by MCI, each Network Element and the connections between Network Elements provided by Bell Atlantic to MCI shall be made available to MCI at Parity and in a Non-Discriminatory manner at the points identified in this Agreement, or additional points made available through the BFR process.

Section 4. Loop

4.1 Definition:

4.1.1 Unbundled Local Loop ("ULL") means a transmission path that extends from the vertical side of a main distribution frame, DSX-panel, or functionally comparable piece of equipment in the subscriber's serving End Office to the Network Rate Demarcation Point (or Network Interface Device ("NID") if installed) in or at a subscriber's premises. The actual loop transmission facilities used to provide a ULL may utilize any of several technologies.

4.1.2 Subject to Part A, Section 29 (Facilities), Bell Atlantic shall allow MCI access to the following ULLs (in addition to those ULLs available under applicable Tariffs) including without limitation unbundled from Local Switching and local transport in accordance with the terms and conditions set forth in this Section 4.

4.1.2.1 2-wire analog voice grade ULL or analog 2W provides an effective 2-wire channel with 2-wire interfaces at each end that is suitable for the transport of analog voice grade (nominal 300 to 3000 Hz) signals and loop-start signaling. The service is more fully described at Exhibit A of this Attachment III.

4.1.2.2 4-wire analog voice grade ULL or analog 4W provides an effective 4-wire channel with 4-wire interfaces at each end that is suitable for the transport of analog voice grade (nominal 300 to 3000 Hz) signals. The service will operate with one of the following signaling types that may be specified when the service is ordered: loop-start, ground-start,

loop-reverse-battery, duplex, and no signaling. The service is more fully described in Exhibit B of this Attachment III.

4.1.2.3 2-wire ISDN digital grade ULL or BRI ISDN provides a channel with 2-wire interfaces at each end that is suitable for the transport of 160 kbps digital services using the ISDN 2B1Q line code. The service is more fully described in Exhibit C of this Attachment III.

4.1.2.4 4-wire DS-1 compatible ULL provides a channel with 4-wire interfaces at each end. Each 4-wire channel is suitable for the transport of 1.544 mbps digital signals simultaneously in both directions using PCM line code. DS-1 compatible ULLs will be available where existing copper facilities can meet the specifications. The service is more fully described in Exhibit C of this Attachment III.

4.1.2.5 ULLs will be offered on the terms and conditions specified herein and on such other terms in applicable Tariffs that are not inconsistent with the terms and conditions set forth herein.

4.1.3 If Bell Atlantic uses integrated digital loop carrier ("DLC") systems to provide the local loop, Bell Atlantic will make alternate arrangements if available, meeting the requirements of this Section 4, to permit MCI to order an existing contiguous ULL with the same provisioning intervals at no additional cost to MCI. These arrangements may, at Bell Atlantic's option, include the following: provide MCI with copper facilities or universal DLC that are acceptable to MCI. Additional arrangements, such as deployment of Virtual Remote Terminals, or allowing MCI to purchase the entire DLC, are subject to the BFR procedures of Section 25 of Part A of this Agreement.

4.2 Loop Components

MCI may, at its option, raise the issue of subloop unbundling (other than NID unbundling, which is addressed in Section 5 of this Attachment III) either through the BFR procedure set forth in Section 25 of Part A of this Agreement, or by cooperating with Bell Atlantic in the design and implementation of a subloop unbundling technical and operational plan. Loop components may include, but are not limited to, the following:

4.2.1 Loop Concentrator/Multiplexer

4.2.2 Loop Feeder

4.2.3 Loop Distribution

5.1 Definition:

5.1.1 "Network Interface Device" or "NID" means the Bell Atlantic provided interface terminating Bell Atlantic's Telecommunications network on the property where the subscriber's service is delivered at a point determined by Bell Atlantic. The NID contains a FCC Part 68 registered jack from which inside wire may be connected to Bell Atlantic's network.

5.1.2 Bell Atlantic shall permit MCIIm to connect MCIIm's loop to the inside wiring of a subscriber's premises through Bell Atlantic's NID in the manner set forth in Section 5.2 herein.

5.2 Access to Network Interface Device

5.2.1 Due to the wide variety of NIDs utilized by Bell Atlantic (based on subscriber size and environmental considerations), MCIIm may access the subscriber's inside wire by any of the following means:

5.2.1.1 Bell Atlantic shall allow MCIIm to connect its loops directly to Bell Atlantic's multi-line residential NID enclosures that have additional space and are not used by Bell Atlantic or any other Telecommunications Carrier to provide service to the premise. MCIIm agrees to install compatible protectors and test jacks, to maintain the protection system and equipment and to indemnify Bell Atlantic pursuant to Part A of this Agreement.

5.2.1.2 In all other cases, MCIIm must establish the connection to Bell Atlantic's NID through an adjoining NID deployed by MCIIm.

5.2.1.2.1 Where an adequate length of inside wire is present and environmental conditions permit, and with the subscriber authorization required by this Agreement and Applicable Law, either Party may remove the inside wire from the other Party's NID and connect that wire to that Party's own NID; or

5.2.1.2.2 Enter the subscriber access chamber or "side" of "dual chamber" NID enclosures for the purpose of extending a connectorized or spliced jumper wire from the inside wire through a suitable "punch-out" hole of such NID enclosures; or

5.2.1.2.3 Request Bell Atlantic to make other rearrangements to the inside wire terminations or terminal enclosure on a time and materials cost basis to be charged to the requesting Party (i.e.,

MCIm, its agent, the building owner or the subscriber). Such charges will be billed to the requesting Party.

5.2.1.3 In no case shall MCIm remove or disconnect Bell Atlantic's loop facilities from Bell Atlantic's NIDs, enclosures, or protectors.

5.2.1.4 In no case shall MCIm remove or disconnect ground wires from Bell Atlantic's NIDs, enclosures, or protectors.

5.2.1.5 In no case shall MCIm remove or disconnect NID modules, protectors, or terminals from Bell Atlantic's NID enclosures.

5.2.1.6 Maintenance and control of premises wiring (inside wire) is the responsibility of the subscriber. Any conflicts between service providers for access to the subscriber inside wire must be resolved by the subscriber.

5.2.1.7 Due to the wide variety of NID enclosures and outside plant environments, Bell Atlantic will work with MCIm to develop specific procedures to establish the most effective means of implementing this Section 5.2.

5.3 Technical Requirements

5.3.1 The NID shall provide an accessible point of connection for the subscriber-owned inside wiring, for Bell Atlantic's facilities, for the distribution media and/or cross connect to MCIm's NID, and shall maintain a connection to ground.

5.3.2 The NID shall be capable of transferring electrical analog or digital signals between the subscriber's inside wiring and the distribution media and/or cross connect to MCIm's NID, consistent with the NID's function at the Effective Date of this Agreement.

5.3.3 Where a Bell Atlantic NID exists, it is provided in its "as is" condition. MCIm may request Bell Atlantic do additional work to the NID in accordance with Section 5.2.1.2.3.

5.4 Interface Requirements

5.4.1 Where an existing Bell Atlantic NID is installed, the NID shall be the interface to subscribers' premises wiring for the existing loop technology at that premises.

Section 6. Distribution

MCIm may, at its option, raise the issue of distribution unbundling through the BFR procedure set forth in Section 25 of Part A of this Agreement.

Section 7. Local Switching

7.1 Definition:

7.1.1 Local Switching is the Network Element that provides MCIm the ability to use switching functionality in a Bell Atlantic end office switch, including all vertical services and/or features that Bell Atlantic already provides, or provides in the future pursuant to the BFR process set forth in Part A, Section 25, out of that switch. MCIm may request modifications to the switching functionality, including the vertical services and/or features, available in a Bell Atlantic end office switch pursuant to the BFR process set forth in Part A, Section 25. Local Switching will be provisioned with a port element, which provides line or trunk side access to Local Switching.

7.1.2 Port element or port means a line card (or equivalent) and associated peripheral equipment on an end office switch which serves as the interconnection between individual loops or individual subscriber trunks and the switching components of an end office switch and the associated switching functionality in that end office switch. Each port is typically associated with one (or more) telephone number(s) which serves as the subscriber's network address. The port element is part of the provision of Local Switching.

7.1.3 Local Switching includes line side and trunk side facilities plus the features, functions, and capabilities of the switch, as set forth in Section 7.1.1. It consists of the line-side port (including connection between a loop termination and a switch line card, telephone number assignment, one primary Directory Listing, presubscription, and access to 911, Operator Services, basic intercept, and Directory Assistance), line and line group features (including appropriate vertical features and line blocking options), usage (including the connection of lines to lines, lines to trunks, trunks to lines, and trunks to trunks), and trunk features (including the connection between the trunk termination and a trunk card). Components of Local Switching, to the extent that they are separately charged, shall be charged at the rates set forth in Attachment I.

7.1.4 Bell Atlantic shall offer, as an optional chargeable feature, daily usage tapes that include the "to and from" number, start time, and stop time, by line port, for all recorded local, access, and toll usage. MCIm may request activation or deactivation of features on a per port basis at any time, and shall compensate Bell Atlantic for the non-recurring charges associated with processing the order.

7.2. Technical Requirements

7.2.1 Bell Atlantic shall route calls to the appropriate trunk or lines for call origination or termination.

7.2.2 Where Technically Feasible, Bell Atlantic will offer Specialized Routing for Local Switching lines and for lines provided to MCI_m under Local Resale. Bell Atlantic's initial deployment of Specialized Routing will route Directory Assistance and Operator Services calls (*i.e.*, 411, 555-1212, 0-, 0+local) to: (i) Bell Atlantic provided platforms; (ii) MCI_m designated platforms; or (iii) third-party platforms. Due to the constraints of the various switches in place in the Bell Atlantic service region, Bell Atlantic will implement a hybrid network solution for Specialized Routing. The hybrid solution encompasses three different technologies: Bell Atlantic's Common Channel Signaling Network/Advanced Intelligent Network (CCSN/AIN) and, for those office and call types not supported by AIN, Specialized Routing Nodes and/or line class codes. The combinations of switch types, call types, and technology solutions currently available are identified in Exhibit D of this Attachment III. Exhibit D is subject to modification upon reasonable prior notification to MCI_m. The following terms and conditions apply to Specialized Routing service:

7.2.2.1 If MCI_m elects the wholesale discount for Local Resale which does not include Bell Atlantic Directory Assistance and Operator Services, MCI_m must request Specialized Routing for all End Offices where they elect to resell Bell Atlantic retail Telecommunications Services using this wholesale discount.

7.2.2.2 Specialized Routing will be activated for all MCI_m Local Resale and Local Switching end user lines and for all applicable call types (*i.e.*, 411, 555-1212, 0-, 0+local) in a requested End Office.

7.2.2.3 MCI_m is responsible for establishing the necessary transport to carry the rerouted calls to its Operator Services platform(s). Trunks will be required for traffic rerouted from the originating End Office and for traffic rerouted from the Specialized Routing Node. Bell Atlantic-supplied Dedicated Transport is available for use with Specialized Routing where facilities are available; in which case rates and charges for such transport will apply in addition to the rates and charges for Specialized Routing.

7.2.2.4 If the necessary trunks are not in place once a subscriber has been converted to MCI_m's local service, then the end user customer will receive a re-order tone.

7.2.2.5 Traffic rerouted via the Specialized Routing Nodes will be handed-off to MCIIm at a Point of Interconnection in the originating LATA.

7.2.2.6 Implementation of Specialized Routing will begin in the requested End Offices in the State no later than ninety (90) days after the beginning of the implementation interval, and will be finished for all requested End Offices in a State within one hundred eighty (180) days after the beginning of the implementation interval. The implementation interval for Specialized Routing will begin upon receipt by Bell Atlantic of a list of the End Offices from which MCIIm wishes to purchase Specialized Routing service.

7.2.2.7 Certain classes of service and/or line types are not supported by AIN-based Specialized Routing. These exceptions, identified in Exhibit E of this Attachment III, will be addressed by Bell Atlantic on a case-by-case BFR basis at MCIIm's request. Additional charges will apply for the development and implementation of the network solutions used to address these exceptions. Exhibit E of this Attachment III is subject to modification upon reasonable prior notification to MCIIm.

7.2.2.8 Due to the use of AIN technology for Specialized Routing, some existing and future AIN-based services may not work with Local Resale lines that employ Specialized Routing. Exhibit E of this Attachment III lists AIN services that are currently known to conflict with Specialized Routing.

7.2.3 Bell Atlantic shall provide standard recorded announcements at Parity.

7.2.4 Where requested by MCIIm, Bell Atlantic will attempt to change a subscriber from Bell Atlantic's services to MCIIm's services without loss of feature availability and functionality. However, dependent on the technical arrangements MCIIm chooses to use to provide their end user services, some feature interaction conflicts and resulting loss of feature availability and functionality may result.

7.2.5 For unbundled Bell Atlantic switching in combination with an unbundled Bell Atlantic loop, Bell Atlantic shall perform routine testing (e.g., mechanized loop tests ("MLT")) at Parity upon receipt of a trouble report from MCIIm.

7.2.6 Bell Atlantic shall repair, restore and maintain Bell Atlantic provided equipment that has produced trouble conditions, at Parity and in a Non-Discriminatory manner, to minimize recurrence of trouble conditions in MCIIm's use of Local Switching.

7.2.7 Bell Atlantic shall control congestion points such as mass calling events, and network routing abnormalities, using capabilities such as automatic call gapping, automatic congestion control, and network routing overflow at Parity and in a Non-Discriminatory manner.

7.2.8 Bell Atlantic shall record billable events, involving usage of the element, and send the appropriate recording data to MCI as outlined in Attachment VIII.

7.2.9 Unbundled switching will include 911 access on the same basis as such access is provided in Bell Atlantic's network.

7.2.10 Bell Atlantic shall provide switching service point ("SSP") capabilities and signaling software to interconnect the signaling links destined to Bell Atlantic STPs at Parity. In the event that Local Switching is provided out of a switch without SS7 capability, and Bell Atlantic unbundled Common Transport is purchased for use with Bell Atlantic's unbundled switching, Bell Atlantic's Tandem Office Switches shall provide this capability at Parity.

7.2.11 Bell Atlantic shall provide interfaces to Adjunct Equipment, which interfaces are identified in this Agreement, at Parity. Bell Atlantic shall provide interfaces to any other Adjunct Equipment at Parity pursuant to the BFR process.

7.2.12 From time to time MCI may request that Bell Atlantic provide unique reports of reasonable performance data regarding a subscriber line, traffic characteristics, or other reasonable elements. To the extent that such reports exceed that which Bell Atlantic provides itself or its subscribers, MCI shall pay reasonable charges for such reports.

7.2.13 Bell Atlantic shall assign each MCI subscriber line an unbundled switching class of service. MCI may request and Bell Atlantic will provide call blocking options (e.g., 900, 976) at Parity.

7.3 Interface Requirements:

7.3.1 Bell Atlantic shall provide the following unbundled switching interfaces:

Analog Basic (POTS) - line side, loop start or ground start signaling

Analog CENTREX - line side, loop start or ground start signaling

Analog PBX - line side, loop start or ground start signaling

Analog DID - trunk side, loop reverse-battery signaling, associated with a PBX

DS1 (DID) - trunk side, associated with a PBX

DS1 (IOF) - trunk side, associated with dedicated unbundled transport

These services will be more fully described in Exhibits F and G of this Attachment III. Additional interfaces may be developed in accordance with the BFR process set forth in Section 25 of Part A of this Agreement.

7.3.2 Bell Atlantic shall offer access to the following at Parity:

7.3.2.1 SS7 signaling or multi-frequency trunking;

7.3.2.2 Interface to MCI or Bell Atlantic Operator Services systems through the use of Specialized Routing, as appropriate;

7.3.2.3 Interface to MCI or Bell Atlantic Directory Assistance Services through the use of Specialized Routing, as appropriate; and

7.3.2.4 Access to other third-party carriers.

7.4 Integrated Services Digital Network ("ISDN")

Implementation of the first customer application of unbundled ISDN switching will require technical and operational coordination and testing by MCI and Bell Atlantic to ensure that the requirements set forth in this section can be met. Should any of these requirements prove technically infeasible, the Parties shall cooperate to determine the requirements applicable to the unbundled service.

7.4.1 Technical Requirements — ISDN

7.4.1.1 Bell Atlantic shall offer data switching providing ISDN that, at a minimum:

7.4.1.1.1 Provides integrated packet handling capabilities at Parity;

7.4.1.1.2 Allows for full 2B+D channel functionality for BRI at Parity; and

7.4.1.1.3 Allows for full 23B+D channel functionality for PRI at Parity;

7.4.1.1.4 Each B channel shall allow for voice, 64 Kbps CSD, and PSD of 128 logical channels at minimum speeds of 19 Kbps throughput of each logical channel up to the total capacity of the B channel.

7.4.1.1.5 Each B channel shall provide capabilities for alternate voice and data on a per call basis.

7.4.1.1.6 The BRI D channel shall allow for call associated signaling, non-call associated signaling and PSD of 16 logical channels at minimum speeds of 9.6 Kbps throughput of each logical channel up to the total capacity of the D channel.

7.4.1.1.7 The PRI D channel shall allow for call associated signaling.

7.4.2 Interface Requirements — ISDN

7.4.2.1 Bell Atlantic shall provide the BRI U interface using 2-wire copper loops in accordance with TR-NWT-000393, January 1991, *Generic Requirements for ISDN Basic Access Digital Subscriber Lines*.

7.4.2.2 Bell Atlantic shall provide the BRI interface using digital subscriber loops adhering to Bellcore TR-NWT-303 specifications to interconnect DLCs.

7.4.2.3 Bell Atlantic shall offer PSD interfaces adhering to the X.25, X.75 and X.75 ANSI and Bellcore requirements. —

7.4.2.4 Bell Atlantic shall offer PSD trunk interfaces operating at 56 kbps.

Section 8. Operator Systems

See Attachment VIII, Section 6.1.3 Directory Assistance Service and 6.1.4 Operator Service.

Section 9. Common Transport

9.1 Definition:

9.1.1 Common Transport consists of interoffice transmission paths between Bell Atlantic Network Elements (illustrated in Figure 1) shared by carriers. Common Transport consists of Bell Atlantic inter-office transport facilities and is distinct and separate from Local Switching. Common Transport routes the call between two Bell Atlantic switches using the existing route(s) that are used by the Bell Atlantic network for Bell Atlantic's end users.

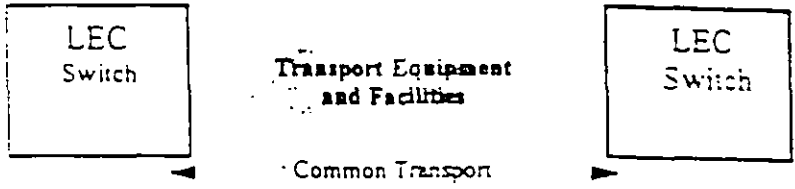

Figure 1

9.2 Technical Requirements

9.2.1 Bell Atlantic shall be responsible for the engineering, provisioning, and maintenance of the underlying equipment and facilities that are used to provide Common Transport.

Section 10. Dedicated Transport

10.1 Definition:

10.1.1 Dedicated Transport is an interoffice transmission path of a fixed capacity between MCI designated locations to which MCI is granted exclusive use. Such locations may include Bell Atlantic Central Offices, other Telecommunication Carrier locations, subscriber premises, or other mutually agreed locations. Dedicated Transport is depicted below in Figure 2.

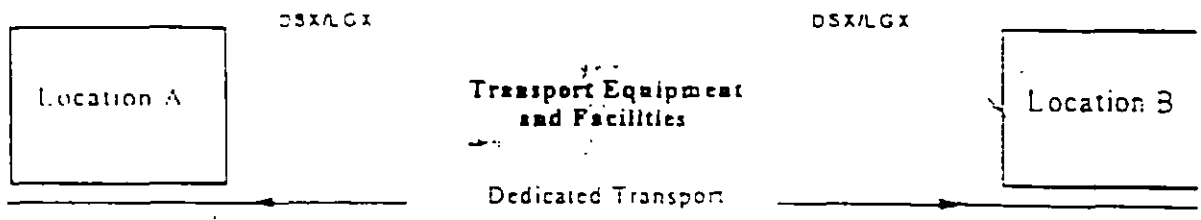

Figure 2

10.1.2 Bell Atlantic shall offer Dedicated Transport as a circuit (e.g., DS0 (voice grade), DS1, STS1 (when available) and DS3) dedicated to MCI.

10.1.3 When Dedicated Transport is provided as a circuit, it will have available (as appropriate):

10.1.3.1 Optional multiplexing functionality:

10.1.3.2 Grooming functionality in accordance with Section 10.3 herein; and.

10.1.3.3 Redundant equipment and facilities necessary to support protection and restoration at Parity and in a Non-Discriminatory manner.

10.2 Technical Requirements

This Section sets forth technical requirements for all Dedicated Transport.

10.2.1 Dedicated Transport shall provide physical diversity at Parity.

10.2.2 MCI_m may request that Bell Atlantic provide additional physical diversity. Bell Atlantic will provide such physical diversity where it is available, at Bell Atlantic's prevailing additional charge, if any. If physical diversity is not reasonably available in response to MCI_m's request, then MCI_m may order such additional physical diversity by submitting a request for special construction.

10.2.3 Dedicated Transport shall include DSX terminations at one or both ends, as applicable, in Bell Atlantic's Central Office location.

10.2.4 Bell Atlantic shall offer DCS and multiplexing, both together with and separately from Dedicated Transport.

10.3 Digital Cross Connect System ("DCS")

10.3.1 Definition:

10.3.1.1 DCS is a device which provides electronic cross-connection of digital signal level 0 ("DS0") or higher transmission bit rate digital channels within physical interface facilities. Types of DCSs include but are not limited to DCS I/Os, where the nomenclature I/O denotes interfaces typically at the DS1 rate or greater with cross-connection typically at the DS0 rate.

10.3.2 DCS Technical Requirements

10.3.2.1 DCS shall provide cross connection of the channels designated by MCI_m, either through service orders or by using Bell Atlantic's Intellimux capabilities.

10.3.2.2 Bell Atlantic shall continue to administer and maintain DCS, including updates to the control software to current available releases, at Parity.

10.3.2.3 Bell Atlantic shall provide various types of Digital Cross Connect Systems including:

10.3.2.3.1 DS0 cross connects (typically termed DCS 1/0).

10.3.2.3.2 Additional DCS types shall be requested in accordance with the BFR process set forth in Section 25 of Part A of this Agreement.

10.3.2.4 Through Bell Atlantic's Intellimux service capabilities, Bell Atlantic shall provide immediate and continuous configuration and reconfiguration of the channels between the physical interfaces (*i.e.*, Bell Atlantic shall establish the processes to implement cross connects on demand, or permit MCIIm control of such configurations and reconfigurations).

10.3.2.5 Through Bell Atlantic's Intellimux service capabilities, Bell Atlantic shall provide scheduled configuration and reconfiguration of the channels between the physical interfaces (*i.e.*, Bell Atlantic shall establish the processes to implement cross connects on the schedule designated by MCIIm, or permit MCIIm to control such configurations and reconfigurations).

10.3.2.6 DCS shall continuously monitor protected circuit packs and redundant common equipment at Parity.

10.3.2.7 DCS shall automatically switch to a protection circuit pack on detection of a failure or degradation of normal operation at Parity.

10.3.2.8 The equipment used to provide DCS shall be equipped with a redundant power supply or a battery back-up at Parity.

10.3.2.9 Bell Atlantic shall make available for DCSs handling MCIIm services spare facilities and equipment at Parity, necessary for provisioning repairs.

10.3.2.10 Through Bell Atlantic's Intellimux service capabilities, at MCIIm's option, Bell Atlantic shall provide MCIIm currently available performance monitoring and alarm data.

10.3.2.11 At MCIIm's option, Bell Atlantic shall provide MCIIm with the ability to initiate tests on DCS equipment. This will require MCIIm to provide additional facilities from the DCS, back to MCIIm's test center. The DCS can then be used to connect MCIIm's test center ports to other MCIIm circuits.

10.3.2.12 Where available, DCS shall provide multipoint bridging of multiple channels to other DCSs. MCI may designate multipoint bridging to be one-way broadcast from a single master to multiple tributaries, or two-way broadcast between a single master and multiple tributaries.

10.3.2.13 DCS shall multiplex lower speed channels onto a higher speed interface and demultiplex higher speed channels onto lower speed interfaces as designated by MCI.

Section 11. Signaling Link Transport

11.1 Definition:

11.1.1 Bell Atlantic's CCS Access Service ("CCSAS") allows interconnected carriers to exchange signaling information over a communications path which is separate from the message path. The transport portion of CCSAS is provided via a discretely rated dedicated 56 kbps out of band signaling connection between the carrier's Signaling Point of Interconnection ("SPOI") and Bell Atlantic's STP.

11.1.2 Each CCSAS signaling connection provides for two-way digital transmission at speeds of 56 kbps. The connection to Bell Atlantic's STP pair can be made from either the carrier's signaling point ("SP"), which requires a minimum of two 56 kbps circuits, or from the carrier's STP pair, which requires a minimum of four (4) pairs of 56 kbps circuits.

11.1.3 STP locations are set forth in National Exchange Carrier Association ("NECA") Tariff F.C.C. No. 4. Carriers ordering CCSAS are subject to the technical requirements specified in Bell Atlantic Tariff F.C.C. No. 1, Sections 2.3.9.1, 2.3.10 (B) (9) and 2.3.10 (9). Testing and certification reference documentation shall be pursuant to Bell Atlantic Tariff F.C.C. No. 1, Section 6.4.3 (A).

11.1.4 Each Party shall provide the other Party with access to databases and associated signaling necessary for call routing and completion by providing SS7 CCS interconnection in accordance with existing Tariffs, and interconnection and access to toll free databases, LIDB, and any other necessary databases in accordance with existing Tariffs and/or agreements with other unaffiliated carriers. Alternatively, either Party may secure CCS Interconnection from a commercial SS7 hub provider, and in that case the other Party will permit the purchasing Party to access the same databases as would have been accessible if the purchasing Party had connected via SS7 CCS directly to the other Party's CCS network.

11.1.5 Bell Atlantic shall permit MCI to access Bell Atlantic's LIDB to validate calling card numbers and requests for bill-to-third-party or collect billing. Bell Atlantic shall provide LIDB access at Parity and in a Non-Discriminatory manner by a SS7 formatted data query before call completion to determine the validity of the billing method requested by the caller. LIDB will respond with a SS7 formatted confirmation of validity or denial of the requested billing option.

11.1.6 The Parties will provide CCS Signaling to one another, where and as available, in conjunction with all local traffic, toll traffic, meet point billing traffic, and transit traffic. The Parties will cooperate on the exchange of TCAP messages to facilitate interoperability of CCS-based features between their respective networks, including all CLASS features and functions, to the extent each Party offers such features and functions to its subscribers. All CCS signaling parameters will be provided upon request (where available), including called party number, Calling Party Number, originating line information, calling party category, and Charge Number. All privacy indicators will be honored. The Parties will follow all relevant OBF adopted standards pertaining to CIC/OZZ codes. Where CCS Signaling is not available, in-band multi-frequency ("MF") wink start signaling will be provided. Any such MF arrangement will require a separate local trunk circuit between the Parties' respective Switches; in such an arrangement, each Party will outpulse the full ten-digit telephone number of the called party to the other party with appropriate call set-up and ANI where available, at Parity.

11.1.7 The following publications describe the practices, procedures and specifications generally utilized by Bell Atlantic for signaling purposes and is listed herein to assist the Parties in meeting their respective interconnection responsibilities related to signaling:

11.1.7.1 Bellcore GR-905-CORE, Issue 1, March 1995, and subsequent issues and revisions;

11.1.7.2 Bell Atlantic Supplement Common Channel Signaling Network Interface Specification, Bell Atlantic-905, December 1990; Issue, Supplement 1, June 1992; Supplement 2, August 1992; Supplement 3, January 1993; and

11.1.7.3 Bell Atlantic AIN SMS Network Disclosure (Date: December 1996, on Bell Atlantic World Wide Web site).

11.1.8 Each Party shall charge the other Party mutual and reciprocal rates for CCS Signaling as follows: Bell Atlantic shall charge MCI in accordance with Attachment I hereto and applicable Tariffs; MCI shall charge Bell Atlantic rates equal to the rates Bell Atlantic charges MCI, unless MCI's Tariffs for CCS

signaling provide for lower generally available rates, in which case MCI shall charge Bell Atlantic such lower rates.

11.1.9 MCI must meet interconnection certification testing requirements of the SS7 network before interconnection is permitted, and also before changes occur within the MCI SS7 network.

Section 12. Signaling Transfer Points ("STPs")

12.1 Definition:

12.1.1 Bell Atlantic's CCSAS allows interconnected carriers to exchange signaling information over a communications path which is separate from the message path. The discretely rated network termination point where this interconnection takes place is called the Bell Atlantic STP port termination. Figure 3 depicts STPs.

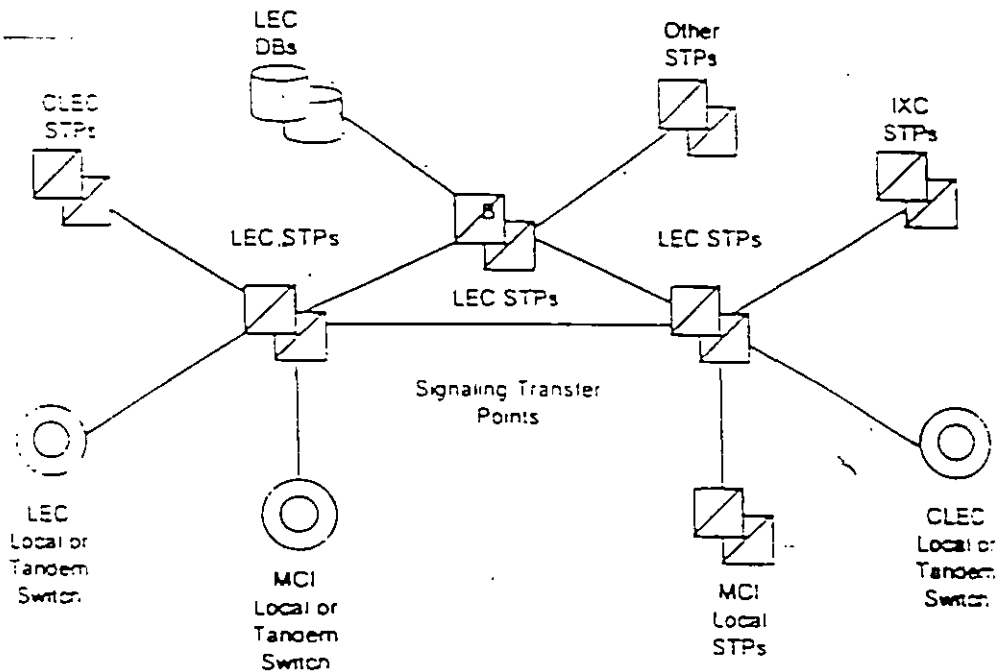

Figure 3

12.1.2 Each CCSAS signaling connection provides for two-way digital transmission at speeds of 56 kbps. The connection to Bell Atlantic's STP pair can be made from either the carrier's STP, which requires a minimum of two (2) 56 kbps circuits, or from the carrier's STP pair, which requires a minimum of four (4) pairs of 56 kbps circuits.

12.1.3 STP locations are set forth in National Exchange Carrier Association ("NECA") Tariff F.C.C. No. 4. Carriers ordering CCSAS are subject to the technical requirements specified in Bell Atlantic Tariff F.C.C. No. 1, Sections 2.3.9.1, 2.3.10 (B) (9) and 2.3.10 (9). See Bell Atlantic Tariff F.C.C. No. 1, Section 6.4.3 (A) for testing and certification reference documentation).

12.2 Technical Requirements

12.2.1 STPs shall provide access to all other Network Elements connected to the Bell Atlantic network. These include:

12.2.1.1 Bell Atlantic Local Switching or Tandem Switching;

12.2.1.2 Bell Atlantic Service Control Points/databases;

12.2.1.3 Third-party local or Tandem Switching systems; and

12.2.1.4 Third-party-provided STPs.

12.2.2 The connectivity provided by STPs shall fully support the functions of all other Network Elements connected to the Bell Atlantic SS7 network. This explicitly includes the use of the Bell Atlantic SS7 network to convey messages which neither originate nor terminate at a signaling end point directly connected to the Bell Atlantic SS7 network (*i.e.*, transit messages). When the Bell Atlantic SS7 network is used to convey transit messages, there shall be no alteration of the integrated services digital network user part ("ISDNUP") or Transaction Capabilities Application Part ("TCAP") user data that constitutes the content of the message.

12.2.3 If a Bell Atlantic Tandem Switch routes calling traffic, based on dialed or translated digits, on SS7 trunks between an MCI local Switch and third-party local Switch, Bell Atlantic's SS7 network shall convey the TCAP messages that are necessary to provide call management features (automatic callback, automatic recall, and screening list editing) between the MCI local STPs and the STPs that provide connectivity with the third-party local Switch, even if the third-party local Switch is not directly connected to Bell Atlantic's STPs, providing that the third-party Switch is located in the same LATA.

12.2.4 In cases where the destination signaling point is a Bell Atlantic local or Tandem Switching system or database, or is an MCI or third-party local or Tandem Switching system directly connected to Bell Atlantic's SS7 network, Bell Atlantic STPs shall perform final GTT of messages to the destination and SCCP Subsystem Management of the destination. In all other cases, STPs shall perform intermediate GTT of messages to a gateway pair of STPs in an SS7 network

connected with the Bell Atlantic SS7 network, and shall not perform SCCP subsystem management of the destination.

12.3 Interface Requirements

12.3.1 Bell Atlantic shall provide the following STPs options to connect MCI or MCI-designated Local Switching systems or STPs to the Bell Atlantic SS7 network:

12.3.1.1 An A-link interface from MCI Local Switching systems; and

12.3.2 Each type of interface shall be provided by one or more sets (layers) of signaling links, as follows:

12.3.2.1 An A-link layer shall consist of two links, as depicted in Figure 4.

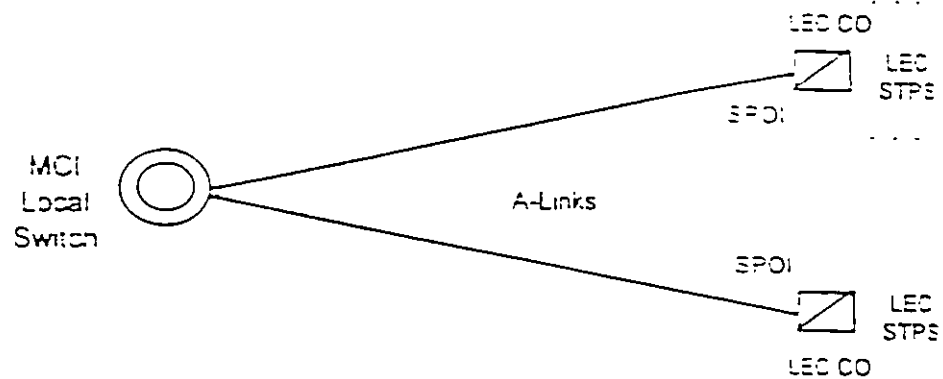

Figure 4. A-Link Interface

12.3.3 The Signaling Point of Interconnection ("SPOI") for each link shall be located at a cross-connect element, such as a DSX-1, in the Central Office where the Bell Atlantic STP is located. There shall be a DS1 or higher rate transport interface at each of the SPOIs. Each signaling link shall appear as a DS0 channel within the DS1 or higher rate interface.

12.4 Message Screening

12.4.1 Bell Atlantic shall set message screening parameters so as to accept messages from MCI local or tandem switching systems destined to any signaling point in the Bell Atlantic SS7 network with which the MCI switching system has a legitimate signaling relation.

12.4.2 Bell Atlantic shall set message screening parameters so as to accept messages from MCI local or tandem switching systems destined to any signaling point or network interconnected to the Bell Atlantic SS7 network with which the MCI switching system has a legitimate signaling relation.

12.4.3 Bell Atlantic shall set message screening parameters so as to accept messages destined to an MCI local or tandem switching system from any signaling point or network interconnected to the Bell Atlantic SS7 network with which the MCI switching system has a legitimate signaling relation.

12.4.4 Bell Atlantic shall set message screening parameters so as to accept and send messages destined to an MCI SCP from any signaling point or network interconnected to the Bell Atlantic SS7 network with which the MCI SCP has a legitimate signaling relation, provided Bell Atlantic receives proper notification and agreement from the owner of such other networks.

12.5 STP Requirements

12.5.1 Bell Atlantic shall provide MTP and SCCP protocol interfaces in accordance with sections relevant to the MTP or SCCP in the following specifications:

12.5.1.1 Bellcore GR-905-CORE, Issue 1, March 1, Common Channel Signaling Network Interface Specification ("CCSNIS") Supporting Network Interconnection, Message Transfer Part ("MTP"), and Integrated Services Digital Network User Part ("ISDNUP"), and

Section 13. Call Related Databases and AIN

13.1 Definition:

13.1.1 "Call Related Databases" are the Network Elements that provide the functionality for storage of, and access to, information required to route and complete a particular call. Call Related Databases include, but are not limited to: LIDB, Toll Free Number Database, and AIN databases.

13.1.2 A Service Control Point ("SCP") is a specific type of database Network Element deployed in a Signaling System 7 ("SS7") network that executes service application logic in response to SS7 queries sent to it by a switching system also connected to the SS7 network.

13.2 Technical Requirements for Call Related Databases

Requirements for Call Related Databases within this section address storage of information, access to information (e.g., signaling protocols, response times), and administration of information (e.g., provisioning, administration, and maintenance). All Call Related Databases shall be provided to MCI in accordance with the following requirements, except where such a requirement is superseded by specific requirements set forth in Subsections 13.3 through 13.5:

13.2.1 Bell Atlantic shall provide physical interconnection to SCPs through the SS7 network and protocols, as specified in Section 12 of this Attachment, with TCAP as the application layer protocol.

13.2.2 Bell Atlantic shall provide physical interconnection to databases via existing interfaces and industry standard interfaces and protocols (e.g., 56 Kb TCP/IP).

13.2.3 The reliability of interconnection options shall be consistent with requirements for diversity and survivability as specified in Section 12 of this Attachment (which applies to both SS7 and non-SS7 interfaces).

13.2.4 Call Related Database functionality shall be available at Parity. If, based on information available through the process set forth in Section 3, MCI believes the functionality is inadequate to meet its needs, it may initiate a BFR.

13.2.5 Bell Atlantic shall complete database transactions (i.e., add, modify, delete) for MCI subscriber records stored in Bell Atlantic databases at Parity.

13.2.6 Bell Atlantic shall provide database maintenance consistent with the maintenance requirements as specified in this Agreement (e.g., notification of Bell Atlantic network affecting events, testing).

13.2.7 Bell Atlantic shall provide billing and recording information to track database usage consistent with connectivity billing and recording requirements for Call Related Databases as specified in this Agreement (e.g., recorded message format and content, timeliness of feed, data format and transmission medium).

13.2.8 Bell Atlantic shall provide Call Related Databases in accordance with the physical security requirements specified in this Agreement.

13.2.9 Bell Atlantic shall provide Call Related Databases in accordance with the logical security requirements specified in this Agreement.

13.3. Line Information Database ("LIDB")

This Subsection 13.3 defines and sets forth additional requirements for the Line Information Database. This Subsection 13.3 supplements the requirements of Subsection 13.2 and 13.5.

13.3.1 Definition:

LIDB is a transaction-oriented database accessible through CCS networks. It contains records associated with subscriber line numbers and special billing numbers (in accordance with the requirements in the technical reference in GR-1158-CORE OSSGR, Section 22.3). LIDB accepts queries from other Network Elements, or MCI's network, and provides appropriate responses. The query originator need not be the owner of LIDB data. LIDB queries include functions such as screening billed numbers that provides the ability to accept collect or third number billing calls and validation of telephone line number based non-proprietary calling cards. The interface for the LIDB functionality is the interface between the Bell Atlantic CCS network and other CCS networks. LIDB also interfaces to administrative systems. The administrative system interface provides Bell Atlantic work centers with an interface to LIDB for functions such as provisioning, auditing of data, access to LIDB measurements and reports.

13.3.2 Technical Requirements

13.3.2.1 Prior to the availability of a long-term solution for NP, Bell Atlantic shall enable MCI to store in Bell Atlantic's LIDB any subscriber line number or special billing number record, (in accordance with the technical reference in GR-1158-CORE OSSGR, Section 22.3) whether ported or not, for which the NPA-NXX or NXX-0/XX group is supported by that LIDB.

13.3.2.2 Prior to the availability of a long-term solution for NP, Bell Atlantic shall enable MCI to store in Bell Atlantic's LIDB any subscriber line number or special billing number (in accordance with the technical reference in GR-1158-CORE OSSGR, Section 22.3) record, whether ported or not, and NPA-NXX and NXX-0/XX Group Records, belonging to an NPA-NXX or NXX-0/XX assigned to MCI.

13.3.2.3 Subsequent to the availability of a long-term solution for NP, Bell Atlantic shall enable MCI to store in Bell Atlantic's LIDB any subscriber line number or special billing number (in accordance with the technical reference in GR-1158-CORE OSSGR, Section 22.3) record, whether ported or not, regardless of the number's NPA-NXX or NXX-0/XX.

13.3.2.4 Bell Atlantic shall perform the following LIDB functions (i.e., processing of the following query types as defined in the technical reference in GR-1158-CORE OSSGR, Section 22.3) for MCI's subscriber records in LIDB:

13.3.2.4.1 Billed number screening (provides information such as whether the billed number may accept collect or third number billing calls); and

13.3.2.4.2 Calling card validation.

13.3.2.5 Bell Atlantic shall process MCI's subscriber records in LIDB at least at Parity with Bell Atlantic subscriber records, with respect to other LIDB functions (as defined in the technical reference in GR-1158-CORE OSSGR, Section 22.3). Bell Atlantic shall indicate to MCI what additional functions (if any) are performed by LIDB in Bell Atlantic's network.

13.3.2.6 Within two (2) weeks after a request by MCI, Bell Atlantic shall provide MCI with a list of the subscriber data items which MCI would have to provide in order to support billed number screening and calling card validation. The list shall indicate which data items are essential to LIDB function, and which are required only to support certain services. For each data item, the list shall show the data formats, the acceptable values of the data item and the meaning of those values.

13.3.2.7 Bell Atlantic shall provide LIDB systems with rates of operating deficiencies at Parity. If, based on information available through the process set forth in Section 3, MCI believes that the rate of deficiencies is inadequate to meet its needs, it may initiate a BFR.

13.3.2.8 Bell Atlantic shall provide MCI with the capability to provision (e.g., to add, update, and delete) NPA-NXX and NXX-01XX group records, and line number and special billing number records, associated with MCI subscribers, directly into Bell Atlantic's LIDB provisioning process.

13.3.2.9 As directed by MCI or the new local service provider, in the event that end user subscribers change their local service provider, Bell Atlantic shall maintain subscriber data (for line numbers, card numbers, and for any other types of data maintained in LIDB), as mutually agreed by the Parties, so that such subscribers shall not experience any interruption of service, except for any interruption associated with a LIDB-only service order transaction at Parity.

13.3.2.10 All additions and updates of MCIIm data to the LIDB shall be solely at the direction of MCIIm. Bell Atlantic will process orders from other CLECs or from Bell Atlantic for subscribers that choose to migrate from MCIIm to another provider.

13.3.2.11 Bell Atlantic shall provide priority updates to LIDB for MCIIm data upon MCIIm's request (e.g., to support fraud protection) at Parity.

13.3.2.12 Bell Atlantic shall accept queries to LIDB associated with MCIIm subscriber records, and shall return responses in accordance with the requirements of this Section 13.

13.4 Toll Free Number Database

The "Toll Free Number Database" is an SCP that provides functionality necessary for toll free (e.g., 800 and 888) number services by providing routing information and additional features during call set-up in response to queries from SSPs. This Subsection 13.4 supplements the requirements of Subsection 13.2 and 13.5. Bell Atlantic shall provide the Toll Free Number Database in accordance with the following:

13.4.1 Technical Requirements

13.4.1.1 Bell Atlantic shall make the Bell Atlantic Toll Free Number Database available for MCIIm to query, from MCIIm's designated switch including Local Switching, with a toll-free number and originating information.

13.4.1.2 The Toll Free Number Database shall return caller identification and, where applicable, the queried toll free number, translated numbers and instructions as it would in response to a query from a Bell Atlantic switch.

13.4.2 Interface Requirements

The signaling interface between the MCIIm or other local switch and the Toll Free Number Database shall use the TCAP protocol as specified in Part A, Section 15 (Technical References), together with the signaling network interface as specified in Part A, Section 15 (Technical References).

13.5 Advanced Intelligent Network ("AIN") Access, Service Creation Environment and Service Management System ("SCE/SMS") Advanced Intelligent Network Access

13.5.1 Bell Atlantic shall provide access to any and all Bell Atlantic service applications resident in Bell Atlantic's SCP. Such access may be from MCI's switch or Bell Atlantic's unbundled local switch.

13.5.2 SCE/SMS AIN access shall provide MCI the ability to create service applications in the Bell Atlantic SCE and deploy those applications via the Bell Atlantic SMS to the Bell Atlantic SCP. This interconnection arrangement shall provide MCI access to the Bell Atlantic development environment in a manner at least at Parity with Bell Atlantic's ability to deliver its own AIN-based services. SCE/SMS AIN Access is the creation and provisioning of AIN services in the Bell Atlantic network. See Figure 5 below.

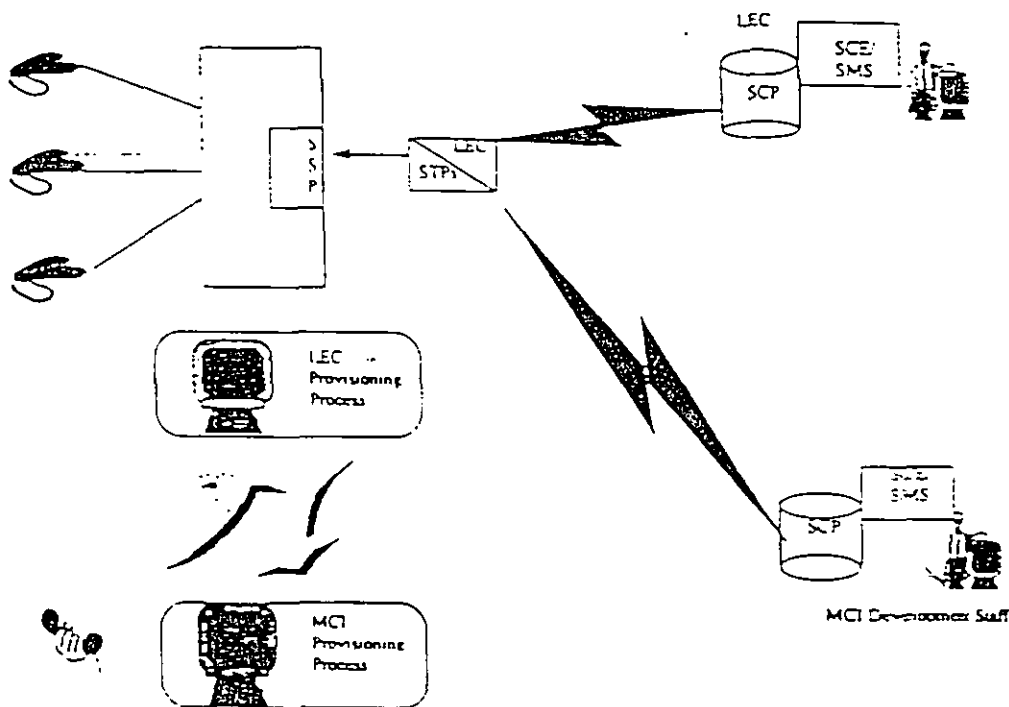

Figure 5

13.5.3 Bell Atlantic shall make SCE hardware, software, testing and technical support (e.g. help desk, system administrator) resources available to MCI. Scheduling of SCE resources shall allow MCI at least equal priority to Bell Atlantic.

13.5.4 The Bell Atlantic SCE/SMS shall allow for multi-user access. Source code (i.e. AIN service applications and process flow design developed by an MCI service designer/creator to provide AIN based services) management and other logical security functions will be provided.

13.5.5 Bell Atlantic shall provide reasonable protection to MCIIm service logic and data from unauthorized access, execution or other types of compromise.

13.5.6 Bell Atlantic or a designated vendor shall provide for service creation training, documentation, and technical support of MCIIm development staff at Parity with that provided to Bell Atlantic's own development staff. Training sessions shall be "suitcased" to MCIIm facilities or delivered at Bell Atlantic facilities at MCIIm's cost, at MCIIm's discretion, subject to vendor's requirements.

13.5.7 When MCIIm selects SCE/SMS AIN access, Bell Atlantic shall provide for a secure, controlled access environment on-site as well as via remote data connections (i.e., ISDN circuit switched data).

13.5.8 When MCIIm selects SCE/SMS AIN access, Bell Atlantic shall allow MCIIm to transfer data forms and/or tables to the Bell Atlantic SCP via the Bell Atlantic SMS (e.g., service customization and subscriber subscription) in a manner consistent with how Bell Atlantic provides that capability to itself.

13.5.9 When MCIIm selects SCE/SMS AIN access for providing services on MCIIm's network, the Parties will work cooperatively to resolve technical and provisioning issues.

Section 14. Tandem Switching

14.1 Definition:

14.1.1 Tandem Switching includes trunk-connect facilities, the basic switching function of connecting trunks to trunks, and the functions that are centralized in tandem switches. Tandem Switching creates a temporary transmission path between interoffice trunks that are interconnected at a Bell Atlantic access tandem switch for the purpose of routing a call or calls.

14.2 Technical Requirements

14.2.1 Tandem Switching shall provide:

14.2.1.1 Signaling to establish a tandem connection:

14.2.1.2 Screening and routing at Parity:

14.2.1.3 To the extent Technically Feasible and at Parity, Tandem Switching shall provide recording of billable events:

14.2.1.4 Tandem Switching shall provide AIN triggers supporting AIN features at Parity with its provision of such triggers for Bell Atlantic subscribers;

14.2.1.5 Bell Atlantic's Tandem Switching shall provide access to toll free and Number Portability databases in the same manner as it provides such access to itself and its Bell Atlantic subscribers;

14.2.1.6 Tandem Switching shall provide all trunk interconnections, where available, in Bell Atlantic's access tandems; and

14.2.1.7 Tandem Switching shall accept connections (including the necessary signaling and trunking interconnections) between end offices, IXCs, ITCs, CAPs and CLEC switches that subtend/interconnect at the same tandem.

14.2.2 Tandem Switching shall provide local tandeming functionality between two End Offices that subtend/interconnect at the same tandem, including two offices belonging to different CLECs (e.g., between an MCIIm end office and the end office of another CLEC).

14.2.3 Tandem Switching shall preserve CLASS/CLASS features and Caller ID as traffic is processed on SS7 trunk groups at Parity. Additional signaling information and requirements are provided in Section 12.

14.2.4 Bell Atlantic shall perform routine testing and fault isolation on the underlying switch that is providing Tandem Switching and all its interconnections at Parity with its performance of such testing for its own subscriber services. When commonly available, the results of the testing shall be made immediately available to MCIIm.

14.2.5 Tandem Switching shall control congestion using capabilities such as automatic congestion control and network routing overflow. Congestion control provided or imposed on MCIIm traffic shall be at Parity with controls being provided or imposed on Bell Atlantic traffic for itself and its subscribers.

14.2.6 Tandem Switching shall route calls to Bell Atlantic or MCIIm endpoints or platforms for which Tandem Switching is provided. For Tandem Switching with unbundled Common Transport, call routing including overflow is accomplished as Bell Atlantic's network normally routes the calls. For Tandem Switching with unbundled Dedicated Transport, specific routing may be requested through the BFR process.

14.2.7 Tandem Switching shall process originating toll-free traffic received from an MCIIm local switch.

14.2.8 In support of AIN triggers and features, Tandem Switching shall provide SSP capabilities at Parity with Bell Atlantic's provision of these capabilities for its own subscribers under the same circumstances when these capabilities are not available from Local Switching.

14.2.9 The Local Switching and Tandem Switching functions may be combined in an office. If this is done, both Local Switching and Tandem Switching shall provide all of the functionality required of each of those Network Elements in this Agreement.

14.3 Interface Requirements

14.3.1 Tandem Switching shall interconnect, with direct trunks, to all carriers with which Bell Atlantic interconnects.

14.3.1.1 Transit traffic that is originated by an ITC or wireless carrier shall be settled in accordance with the terms of an appropriate IntraLATA Telecommunications Services Settlement Agreement between the Parties substantially in the form appended hereto as Exhibit H. Meet-Point Billing compensation arrangements as described in Section 3 of Attachment VIII shall be utilized for compensation for the joint handling of toll traffic.

14.3.1.2 Bell Atlantic expects that most networks involved in transit traffic will deliver each call to each involved network with CCS and the appropriate TCAP message to facilitate full interoperability of those services supported by Bell Atlantic and billing functions. In all cases, each Party shall follow the Exchange Message Record ("EMR") standard and exchange records between the Parties and with the terminating carrier to facilitate the billing process to the originating network.

14.3.1.3 Transit traffic to and from MCI shall be routed over the traffic exchange trunks.

14.3.2 Bell Atlantic shall provide signaling necessary to provide Tandem Switching with feature functionality impacts and effects at Parity.

Section 15. Additional Requirements

This Section 15 of Attachment III sets forth the additional requirements for Network Elements which Bell Atlantic agrees to offer to MCI under this Agreement.

15.1 Cooperative Testing

15.1.1 Definition:

"Cooperative Testing" means that both Bell Atlantic and MCI shall cooperate with reasonable requests from the other to (i) ensure that the Network Elements and ancillary functions and additional requirements being provided to MCI by Bell Atlantic are in compliance with the requirements of this Agreement, (ii) test the overall functionality of various Network Elements and ancillary functions provided by Bell Atlantic to MCI in Combination with each other or in Combination with other equipment and facilities provided by MCI or third-parties, (iii) test the overall functionality of services provided by third-parties involving or combining Network Elements provided by Bell Atlantic and services provided by MCI, and (iv) ensure that billing data can be provided to MCI and Bell Atlantic.

15.1.2 Requirements

Within forty-five (45) days after the Effective Date of this Agreement, MCI and Bell Atlantic will agree upon a process to resolve technical issues relating to interconnection of MCI's network to Bell Atlantic's network and Network Elements and ancillary functions. The agreed upon process shall include procedures for escalating disputes and unresolved issues up through higher levels of each Party's management. If MCI and Bell Atlantic do not reach agreement on such a process within forty-five (45) days, any issues that have not been resolved by the Parties with respect to such process shall be submitted to the procedures set forth in Part A, Section 24 (Dispute Resolution Procedures) of this Agreement unless both Parties agree to extend the time to reach agreement on such issues.

15.1.2.1 Where mutually agreed (e.g., POT bays in the common area associated with physical Collocation), Bell Atlantic shall provide MCI access for testing MCI facilities at interfaces between a Bell Atlantic Network Element, or at interfaces between a Bell Atlantic Combination, and MCI equipment or facilities. This access shall be available seven (7) days per week, twenty-four (24) hours per day.

15.1.2.2 When mutually agreed, Bell Atlantic shall temporarily provision MCI designated Local Switching features (e.g., customized routing) for testing. MCI and Bell Atlantic shall mutually agree on the procedures to be established between Bell Atlantic and MCI to expedite such provisioning processes for feature testing.

15.1.2.3 Upon reasonable request, Bell Atlantic and MCI shall provide technical staff to meet with each other to provide required support for Cooperative Testing.

15.1.2.4 Dedicated Transport and ULL may experience alarm conditions due to in-progress tests. When an entire Bell Atlantic facility is dedicated to MCI services, Bell Atlantic shall not remove such facility from service without obtaining MCI's prior approval.

15.1.2.5 Bell Atlantic shall provide to MCI electronic access to 105 type responders, 100-type test lines, or 102-type test lines associated with any circuits under test.

15.1.2.6 MCI and Bell Atlantic shall endeavor to complete Cooperative Testing as stated in Attachment VIII.

15.1.2.7 MCI may accept or reject the Network Element ordered by MCI if, upon completion of cooperative acceptance testing, the tested Network Element does not meet the requirements stated in applicable technical references included in Appendix 1 (Technical Reference Schedule) of Part A.

15.2 Protection, Restoration, and Disaster Recovery

15.2.1 Scope

This Section refers specifically to requirements on the use of redundant network equipment and facilities for protection, restoration, and disaster recovery.

15.2.2 Requirements

15.2.2.1 Bell Atlantic shall provide protection, restoration, and disaster recovery capabilities at Parity with those capabilities provided for their own services, facilities and equipment (e.g., equivalent circuit pack protection ratios, facility protection ratios).

15.2.2.2 Bell Atlantic shall provide Network Elements equal priority in protection, restoration, and disaster recovery as provided to their own services, facilities and equipment.

15.2.2.3 Bell Atlantic shall provide Network Elements equal priority in the use of spare equipment and facilities as provided to their own services, facilities and equipment.

15.2.2.4 Bell Atlantic shall restore Network Elements which are specific to MCI end user subscribers on a priority basis as MCI may designate at Parity.

15.3 Synchronization

15.3.1 Definition:

"Synchronization" is the function which keeps all digital equipment in a communications network operating at the same average frequency. With respect to digital transmission, information is coded into discrete pulses. When these pulses are transmitted through a digital communications network, all synchronous Network Elements are traceable to a stable and accurate timing source. Network synchronization is accomplished by timing all synchronous Network Elements in the network to a stratum 1 source so that transmission from these network points have the same average line rate.

15.3.2 Technical Requirements

The following requirements are applicable to the case where Bell Atlantic provides synchronization services to equipment that MCI owns and operates within a Bell Atlantic location. In addition, these requirements apply to synchronous equipment that is owned by Bell Atlantic and is used to provide a Network Element to MCI. Synchronization services by Bell Atlantic shall be subject to rates and charges to be determined.

15.3.2.1 The synchronization of clocks within digital networks is divided into two parts: intra-building and inter-building. Within a building, a single clock is designated as the building integrated timing supply ("BITS"), which provides all of the DS1 and DS0 synchronization references required by other clocks in such building. This is referred to as intra-building synchronization. The BITS receives synchronization references from remotely located BITS. Synchronization of BITS between buildings is referred to as inter-building synchronization.

15.3.2.2 To implement a network synchronization plan, clocks within digital networks are divided into four stratum levels. All clocks in strata 2, 3, and 4 are synchronized to a stratum 1 clock, that is, they are traceable to a stratum 1 clock. A traceable reference is a reference that can be traced back through some number of clocks to a stratum 1 source. Clocks in different strata are distinguished by their free running accuracy or by their stability during trouble conditions such as the loss of all synchronization references.

15.3.2.2.1 Intra-Building

15.3.2.2.1.1 Within a building, there may be different kinds of equipment that require synchronization at the DS1 and DS0 rates. Synchronization at the DS1 rate is accomplished by the frequency synchronizing presence of buffer stores at various DS1 transmission interfaces. Synchronization at the DS0 rate is accomplished by using a composite clock signal that phase synchronizes the clocks. Equipment requiring DS0 synchronization frequently does not have adequate buffer storage to accommodate the phase variations among different equipment. Control of phase variations to an acceptable level is accomplished by externally timing all interconnecting DS0 circuits to a single clock source and by limiting the interconnection of DS0 equipment to less than 1,500 cable feet. Therefore, a BITS shall provide DS1 and composite clock signals when the appropriate composite signal is a 64-kHz 5/8th duty cycle, return to zero with a bipolar violation every eighth pulse ("B&RZ").

15.3.2.2.2 Inter-Building

15.3.2.2.2.1 Bell Atlantic shall provide inter-building synchronization at the DS1 rate, and the BITS shall accept the primary and secondary synchronization links from BITS in other buildings. From hierarchical considerations, the BITS shall be the highest stratum clock within the building and Bell Atlantic shall provide operations capabilities (this includes, but is not limited to: synchronization reference provisioning; synchronization reference status inquiries; timing mode status inquiries; and alarm conditions).

15.3.3 Synchronization Distribution Requirements

15.3.3.1 Central Office BITS shall contain redundant clocks meeting or exceeding the requirements for a stratum 3 enhanced clock as specified in ANSI T1.101-1994 and Bellcore *GR-1244 Clocks for the Synchronized Network: Common Generic Criteria*.

15.3.3.2 Central Office BITS shall be powered by primary and backup power sources.

15.3.3.3 If both reference inputs to the BITS are interrupted or in a degraded mode (meaning off frequency greater than twice the minimum accuracy of the BITS, loss of frame, excessive bit errors, or in alarm indication signal), then the stratum clock in the BITS shall provide the necessary bridge in timing to allow the network to operate without a frame repetition or deletion (slip free) with better performance than 1 frame repetition or deletion (slip) per week.

15.3.3.4 DS1s multiplexed into a SONET synchronous payload envelope within an STS-n (where n is defined in ANSI T1.105-1995) signal shall not be used as reference facilities for network synchronization.

15.3.3.5 The total number of Network Elements cascaded from the stratum 1 source shall be minimized.

15.3.3.6 A Network Element shall receive the synchronization reference signal only from another Network Element that contains a clock of equivalent or superior quality (stratum level).

15.3.3.7 Bell Atlantic shall select for synchronization those facilities shown to have the greatest degree of availability (absence of outages).

15.3.3.8 Where possible, all primary and secondary synchronization facilities shall be physically diverse (this means the maximum feasible physical separation of synchronization equipment and cabling).

15.3.3.9 No timing loops shall be formed in any combination of primary and secondary facilities.

15.3.3.10 An operations support system ("OSS") shall continuously monitor the BITS for synchronization related failures or degradation.

15.3.3.11 An OSS shall continuously monitor all equipment transporting synchronization facilities for synchronization related failures or degradation.

15.3.3.12 For non-SONET equipment, Bell Atlantic shall provide synchronization facilities which, at a minimum, comply with the standards set forth in ANSI T1.101-1994.

15.3.3.13 All equipment approved for deployment in Bell Atlantic's network shall meet Bellcore GR-253 and GR-1244 requirements.

Section 16. Basic 911 and E911

See Attachment VIII, Section 6.1.1.

Section 17. Directory Assistance Data

See Attachment VIII, Section 6.1.7.

TABLE OF CONTENTS

Attachment VI Rights of Way, Conduits, Pole Attachments

| | | |
|-------------|--|---------|
| Section 1. | Definitions | VI - 1 |
| Section 2. | Scope of Licenses | VI - 3 |
| Section 3. | Fees and Charges | VI - 4 |
| Section 4. | Advance Payments | VI - 4 |
| Section 5. | Specifications | VI - 5 |
| Section 6. | Legal Requirements | VI - 6 |
| Section 7. | Issuance of Licenses | VI - 7 |
| Section 8. | Pre-License Survey and Make-Ready Work | VI - 8 |
| Section 9. | Construction, Maintenance and Removal of Communications Facilities | VI - 10 |
| Section 10. | Termination of Licenses | VI - 13 |
| Section 11. | Inspection of Licensee's Communications Facilities | VI - 13 |
| Section 12. | Unauthorized Attachment, Utilization or Occupancy | VI - 14 |
| Section 13. | Security Interest | VI - 14 |
| Section 14. | Damages | VI - 15 |
| Section 15. | Insurance | VI - 15 |
| Section 16. | Authorization Not Exclusive | VI - 16 |
| Section 17. | Assignment of Licenses | VI - 16 |
| Section 18. | Additional Terminations | VI - 17 |
| Section 19. | Term of Licenses | VI - 18 |
| Appendix I | Schedule of Fees and Charges | |
| Appendix II | Administrative Forms and Notices | |

ATTACHMENT VI

Rights of Way, Conduits, Pole Attachments

Introduction

This Attachment VI sets forth the terms and conditions applicable to MCI's access to Poles, Conduits and Rights of Way owned or controlled by Bell Atlantic pursuant to Section 224 of the Act.

Section 1. Definitions

As used solely in this Attachment VI, the following terms shall have the following meanings. All other terms defined in the Agreement, including Part B, shall continue to apply within this Attachment.

1.1 Anchor

An assembly (rod and fixed object or plate) designed to resist the pull of a Guy Strand.

1.2 Conduit

A tube structure containing one or more Ducts or Innerducts used to house communication cables, that is owned by Bell Atlantic or with respect to which Bell Atlantic has the right to authorize the occupancy of MCI's Communications Facilities.

1.3 Conduit Occupancy

Occupancy of a Conduit System by any item of MCI's Communications Facilities.

1.4 Conduit Section

Conduit between two adjacent Manholes or between a Manhole and an adjacent Pole or other structure.

1.5 Conduit System

Any combination of Ducts, Innerducts, Conduits, and Manholes joined to form an integrated whole, including Central Office and other cable vaults (excluding controlled environmental vaults).

1.6 Duct/Innerduct

An enclosed raceway for communication facilities contained in a Conduit.

1.7 Guy Strand

A metal cable attached to a Pole and Anchor (or another structure) for the purpose of increasing Pole stability.

1.8 MCI's Communications Facilities

All facilities, including but not limited to cables, equipment and associated hardware, owned or utilized by MCI in providing communication services, which are attached to a Pole or occupy a Conduit or Right of Way.

1.9 Manhole

A subsurface enclosure used for the purpose of installing, operating and maintaining communications facilities, including handholes.

1.10 Make-Ready Work

All work, including but not limited to the rearrangement and/or transfer of Bell Atlantic's existing facilities and administering the rearrangement and/or transfer of the facilities of other licensees, replacement of a Pole, or other changes required to accommodate MCI's Communications Facilities on a Pole, or in a Conduit or Right of Way.

1.11 Pole

A Pole with respect to which Bell Atlantic owns or has the right to authorize the attachment of MCI's Communications Facilities.

1.12 Pole Attachment

Any item of MCI's Communications Facilities affixed to a Pole.

1.12.1 Horizontal attachment is for a single Pole Attachment associated with Pole to Pole construction.

1.12.2 Vertical attachment is for single Pole construction where MCI's facilities are affixed along the vertical axis of the Pole.

1.13 Preliminary Survey

All work, including field inspection and administrative processing, to determine the Make-Ready Work necessary to accommodate MCI's Communications Facilities on a Pole, or in a Conduit or Right of Way.

1.14 Right of Way

A right possessed by Bell Atlantic to use or pass over or under the land of another, with respect to which Bell Atlantic has the right to authorize the usage or passage of MCI's Communications Facilities over or through such land. Notwithstanding the foregoing, for the purposes of this Attachment VI, Right of Way shall also include real property owned by Bell Atlantic that contain Poles or Conduit or that would typically be used for such purposes.

Section 2. Scope of Licenses

2.1 Subject to the provisions of this Agreement, for license applications granted by Bell Atlantic in accordance with Section 7 below, Bell Atlantic hereby grants to MCI, for any lawful communications purpose, a nonexclusive license authorizing the attachment of MCI's Communications Facilities to Poles, or the placement of MCI's Communications Facilities in Bell Atlantic's Conduits or Rights of Way, as specified in the pertinent application.

2.2 No use, however extended, of Poles, Conduits and/or Rights of Way, or payment of any fees or charges required, under this Agreement, shall create or vest in MCI any easements or any other ownership of property rights of any nature in such Poles, Conduits and/or Rights of Way. MCI's rights herein shall be and remain a license. Neither this Agreement nor any license granted hereunder shall constitute an assignment of any of Bell Atlantic's rights to use the public or private property at locations of such Poles, Conduits, and/or Rights of Way.

2.3 Nothing contained in this Agreement shall limit Bell Atlantic's right to locate and maintain its Poles, Conduits and Rights of Way, and to operate its facilities in conjunction therewith, in such a manner as will best enable it to fulfill its own service requirements consistent with its obligations under Applicable Law.

2.4 Bell Atlantic shall grant MCI access to Poles, Conduits and/or Rights of Way at Parity and on a Non-Discriminatory basis, except as may be otherwise permitted under Applicable Law. In cases where Bell Atlantic does not have the right to authorize such access, Bell Atlantic shall reasonably cooperate with MCI in obtaining such permission subject to Bell Atlantic's right to provide a reasonable technical evaluation of the requirements for such access to the owner or other authorizing party. Nothing shall preclude MCI from obtaining any such additional authorization without requesting Bell Atlantic's cooperation. Upon reasonable request by MCI, Bell Atlantic will provide any documentation that is not confidential or privileged in its possession supporting a claim that it does not own or have authority to grant access to a given Right of Way.

Section 3. Fees and Charges

3.1 MCIIm is responsible for all fees and charges applicable in connection with the attachment of its Communications Facilities to a Pole, or occupancy of a Conduit or Right of Way, as specified in Appendix I to this Attachment VI and hereby made a part of this Agreement. Such fees and charges shall be in accordance with Section 224 of the Act.

3.2 Nonpayment of any amount due under this Attachment VI shall constitute a breach by MCIIm of this Agreement and shall be resolved in accordance with Part A, Section 21 (Default and Termination). Late payments shall be subject to fees as prescribed in Attachment VIII, Section 3.

3.3 At such time that MCIIm's "net worth" (as defined under generally accepted accounting principles, hereinafter "Net Worth") fails to exceed \$100,000,000, Bell Atlantic may require a bond in a form satisfactory to Bell Atlantic or other satisfactory evidence of financial security in such amount as Bell Atlantic from time to time may reasonably require to guarantee the performance of all MCIIm obligations hereunder. The amount of the bond or financial security shall not operate as a limitation upon the obligations of MCIIm hereunder; and if MCIIm furnishes a deposit of money pursuant to this section, such deposit may be held during the continuance of this Agreement at the option of Bell Atlantic as security for any and all amounts which are or may become due to Bell Atlantic under this Attachment VI.

3.4 On an annual basis, changes in the amount of the fees and charges specified in Appendix I may be made by Bell Atlantic upon at least sixty (60) days prior written notice to MCIIm in the form of a revised Appendix I, and MCIIm agrees to pay such changed fees and charges provided they are in accordance with Applicable Law. Notwithstanding any other provision of this Agreement, MCIIm may terminate the licenses entered into pursuant to Section 7 below at the end of such notice period if the change in fees and charges is not acceptable to MCIIm, by giving Bell Atlantic written notice of its election to terminate such licenses at least thirty (30) days prior to the end of such notice period.

Section 4. Advance Payments

4.1 At such time that MCIIm's Net Worth fails to exceed \$100,000,000, MCIIm shall be required to make an advance payment to Bell Atlantic prior to:

4.1.1 Any undertaking by Bell Atlantic of a Preliminary Survey or the administrative processing of such a survey in an amount sufficient to cover the estimated charges for completing the specific work operation required; and

4.1.2 Performance by Bell Atlantic of any Make-Ready Work required in an amount sufficient to cover the estimated charges for completing the required Make-Ready Work.

4.2 The amount of the advance payment required (Appendix II, Forms A-1, B-1 and B-4) will be credited against the payment due Bell Atlantic for performing the Prelicense Survey and/or Make-Ready Work.

4.3 Where the advance payment is less than the charge by Bell Atlantic for such work, MCIIm agrees to pay Bell Atlantic within thirty (30) days of receipt of the bill all sums due in excess of the amount of the advance deposit.

4.4 Where the advance payment exceeds the charge by Bell Atlantic for such work, Bell Atlantic shall refund the difference to MCIIm.

Section 5. Specifications

5.1 MCIIm's Communications Facilities shall be placed and maintained in accordance with the requirements and specifications of the current editions of the Bellcore Manual of Construction Procedures ("Blue Book"), the National Electrical Code ("NEC"), the National Electrical Safety Code ("NESC"), the rules and regulations of the Occupational Safety and Health Act ("OSHA"), and regulations or directives of a governing authority having jurisdiction over such subject matter. Where a difference in specifications may exist, the more stringent shall apply.

5.2 MCIIm shall correct all material safety violations within ten (10) days from receipt of written notice from Bell Atlantic. MCIIm shall correct all other non-standard conditions within thirty (30) days from receipt of written notice from Bell Atlantic. If MCIIm does not correct any violation within the aforementioned time limits, Bell Atlantic may at its option correct said conditions at MCIIm's expense.

5.3 Notwithstanding Subsection 5.2 above, when conditions created by MCIIm's Communications Facilities pose an immediate threat to the safety of Bell Atlantic's employees or the public, interfere with the performance of Bell Atlantic's service obligations, or pose an immediate threat to the physical integrity of Bell Atlantic's facilities or structures, Bell Atlantic may perform such work and/or take such action as it deems necessary without first giving written notice to MCIIm. As soon as practicable thereafter, Bell Atlantic will advise MCIIm in writing of the work performed or the action taken and will endeavor to arrange for reaccommodation of MCIIm's facilities so affected. MCIIm shall pay Bell Atlantic for all reasonable costs incurred by Bell Atlantic in performing such work.

5.4 The failure of Bell Atlantic to notify MCIIm of violations or to correct violations pursuant to Subsections 5.2 or 5.3 shall not relieve MCIIm of its responsibility to place and maintain its facilities in a safe manner and condition in accordance with the terms of

this Attachment VI, and shall not relieve MCI of any liability imposed by this Agreement.

5.5 Bell Atlantic and MCI agree to resolve disputes arising under this Attachment VI as set forth in Section 24, Part A of this Agreement.

Section 6. Legal Requirements

6.1 If Bell Atlantic's authority to occupy a Pole, Conduit or Right of Way does not allow MCI to place its facilities thereon or therein without some additional authorization or government approval, MCI shall be responsible for obtaining from the appropriate public and/or private authority any such additional authorization to construct, operate and/or maintain its communication facilities on public and/or private property before it attaches its communication facilities to Poles, or occupies Conduit or Rights of Way, located on such public and/or private property. Evidence of MCI's having obtained such additional authority to so construct and maintain facilities shall be submitted forthwith upon demand.

6.2 No license granted under this Agreement shall extend to any Pole, Conduit or Right of Way where the attachment or placement of MCI's Communication Facilities would result in a forfeiture of rights of Bell Atlantic or its existing licensees to occupy the property on which such Poles, Conduits or Rights of Way are located. If the existence of MCI's Communication Facilities on a Pole, or in a Right of Way or Conduit, would cause a forfeiture of the right of Bell Atlantic or its existing licensees to occupy such property, Bell Atlantic shall promptly notify MCI in writing describing the circumstances of forfeiture with reasonable specificity. Bell Atlantic and MCI shall cooperate in taking reasonable and prompt action to avoid such forfeiture, which may include obtaining a stay or other equitable relief. If such actions are not successful prior to forfeiture becoming imminent, then MCI shall remove its Communications Facilities forthwith upon receipt of written notification from Bell Atlantic. In such case, and provided MCI's facilities were placed in space authorized by Bell Atlantic, Bell Atlantic shall reimburse MCI for the full costs of the Preliminary Survey and Make-Ready Work charges (if any, or if shared and paid by MCI, those charges solely attributable to MCI's facilities) paid by MCI to Bell Atlantic, plus the costs of removing MCI's Communications Facilities; provided that where all parties, including Bell Atlantic, must remove all communications facilities from the property, MCI shall remove its Communications Facilities without reimbursement by Bell Atlantic. If MCI fails to remove said Communication Facilities as provided above, Bell Atlantic may perform or have performed such removal after the expiration of ten (10) days after the receipt of said written notification without liability on the part of Bell Atlantic, and MCI agrees to pay Bell Atlantic or other licensees or both, the cost thereof and for all losses and damages that may result, including, but not limited to, relocation costs of Bell Atlantic's facilities.

Section 7. Issuance of Licenses

7.1 Before MCI shall attach to any Pole, or occupy any portion of a Conduit or Right of Way, MCI shall make written application for and have received written license from Bell Atlantic utilizing the following forms: Appendix II, Forms A-1 and A-2 and/or B-1 through B-3. Bell Atlantic shall follow the same process in attaching to, or occupying, such Poles, Conduits or Rights of Way.

7.2 Bell Atlantic shall process all completed license applications, including the performance of a Preliminary Survey, on a first-come, first-serve basis (including all license applications pertaining to itself) in accordance with the provisions of Sections 7 and 8 of this Attachment VI. Bell Atlantic shall make all access determinations in accordance with the requirements of Applicable Law, considering such factors as capacity, safety, reliability and general engineering considerations to the degree allowed by Section 224 of the Act, or, in the alternative, applicable state law. Bell Atlantic shall inform MCI in writing as to whether an application has been granted or denied (stating the reasons for such denial in reasonable detail) within forty-five (45) days after receipt of such application. Where an application involves an increase in capacity by Bell Atlantic, Bell Atlantic shall take reasonable steps to accommodate requests for access in accordance with Applicable Law, including making such determinations in the same manner as it would for itself. Before denying MCI access based on lack of capacity, Bell Atlantic shall explore potential accommodations in good faith with MCI. MCI shall bear the costs associated with any such expansion performed by Bell Atlantic in accordance with Applicable Law, provided that MCI shall be entitled to recover costs from subsequent licensees (including Bell Atlantic) that attach to or occupy such expanded capacity as provided by Applicable Law. Bell Atlantic shall provide reasonably detailed information on any environmental contamination or other environmental hazards of which it is aware for the specified route within twenty (20) days of the date of the application.

7.3 In order to facilitate MCI's completion of an application, Bell Atlantic shall make commercially reasonable efforts to, within ten (10) business days of a legitimate request identifying the specific geographic area and types and quantities of required structures, provide MCI such maps, plats or other relevant data reasonably necessary to complete the applications described above. All such materials and information shall be treated as Confidential Information by MCI in accordance with the provisions of Part A, Section 22. Such requests shall be processed by Bell Atlantic on a "first-come, first-serve" basis. Bell Atlantic shall also make commercially reasonable efforts to meet with or respond to MCI's inquiries regarding the information supplied to it under this Section 7.3 within five (5) business days following the receipt of such a request for a meeting or inquiry from MCI. Bell Atlantic shall also notify MCI of any environmental contamination or other environmental hazards of which it is aware that would make the placement of facilities within pathways specified by MCI hazardous.

7.4 License applications received by Bell Atlantic from two (2) or more applicants for the same Pole, Conduit Section or Right of Way will be processed by Bell Atlantic according to the order in which the applications are received by Bell Atlantic. Once any additional applicants file an application, Bell Atlantic shall use commercially reasonable efforts to, within twenty (20) days of receipt of the additional application, notify the additional applicant of the following: 1) that a previous application had been received for some or all of the same structures or property; 2) the name and address of the initial applicant; and 3) that the additional applicant may wish to share make ready costs with the initial applicant. The responsibility for arranging for the sharing of make ready costs shall be on the additional applicant. However, the responsibility for transmitting to Bell Atlantic any make ready changes resulting from the additional applicant shall be on the initial applicant, provided that the initial applicant is not obligated to share Make-Ready Work or make ready costs with any subsequent applicant, unless required by Applicable Law. Bell Atlantic shall bill the initial applicant for the entire cost of all work necessary to accommodate both the initial and additional applicants, pursuant to executed Form B-4, Appendix II.

7.5 If within twelve (12) months from the date a license is granted by Bell Atlantic, MCI shall not at a minimum have initiated material construction or similar activity related to its attachment or occupation. MCI's license for the applicable Poles, Conduits or Rights of Way shall automatically terminate and MCI shall remove any communications facilities installed as of such date in accordance with Section 9.10 of this Attachment VI. MCI and any other attachor or occupier (including Bell Atlantic) shall be liable for attachment or occupancy charges commencing on the date that the license is granted if no Make-Ready Work is required, or on the date that any required Make-Ready Work is completed.

7.6 Where Bell Atlantic has available ducts or inner ducts, Bell Atlantic shall make available ducts or inner ducts to MCI for MCI's use in accordance with Applicable Law. No more than one full-sized duct (or one full-sized and one inner duct if both copper and fiber cable are used in the Conduit) shall be assigned as an emergency duct in each Conduit Section. If Bell Atlantic or any other service provider, including MCI, utilizes the last unoccupied full-sized duct in the applicable cross-section, that provider shall promptly, at its expense, reestablish a clear, full-sized duct for emergency restoration or immediately upon the occurrence of an emergency requiring such space.

Section 8: Pre-License Survey and Make-Ready Work

8.1 When an application for attachment to, or occupation of, a Pole, Conduit or Right of Way is submitted by MCI, a Prelicense Survey will be required to determine the existing adequacy of such structures or property to accommodate MCI's Communication Facilities.

8.1.1 The field inspection portion of the Prelicense Survey, which requires the visual inspection of such structures or property, shall be performed by Bell

Atlantic (with participation by MCIIm at its option, for which Bell Atlantic shall provide at least twenty-four (24) hours advance notice). Bell Atlantic shall also perform the administrative processing portion of the Prelicense Survey which includes the processing of the application and the preparation of the Make-Ready Work orders (if necessary), including the notification of other attachers of Bell Atlantic's Make-Ready Work schedule and the provision to MCIIm of a list of such other attachers.

8.1.2 Bell Atlantic shall make commercially reasonable efforts to advise MCIIm in writing of the estimated charges that will apply for its Prelicense Survey work as soon as practicable after receipt of MCIIm's application but no later than ten (10) days from receipt thereof. Bell Atlantic shall receive written authorization from MCIIm before undertaking such work (Appendix II, Form B-1).

Alternatively, MCIIm may pay Bell Atlantic the estimated charges that will apply for a Prelicense Survey with its submission of an application provided that Bell Atlantic has advised MCIIm that standard estimated charges exist for the type of application that is being submitted.

8.2 In the event Bell Atlantic determines that a Pole, Conduit or Right of Way which MCIIm desires to utilize is inadequate or otherwise needs rearrangement or expansion of the existing structures or property to accommodate MCIIm's Communication Facilities, Bell Atlantic will advise MCIIm in writing of the estimated Make-Ready Work charges that would apply to any modifications or expansions of capacity that Bell Atlantic proposes to undertake (Appendix II, Form B-4). The estimated Make-Ready Work charges and completion date shall be given to MCIIm at the time that the application is accepted and access is granted. Bell Atlantic shall complete the steps described in paragraphs 8.1 through 8.2 within forty-five (45) days of the date the application is submitted, excluding the time taken by MCIIm to respond to Bell Atlantic's proposals in paragraph 8.1.2, if applicable.

8.3 MCIIm shall have thirty (30) days after the receipt of said Form B-4 to indicate its written authorization for completion of the required Make-Ready Work and acceptance of the resulting charges. If during such period MCIIm presents Bell Atlantic with a proposal from a Bell Atlantic-authorized subcontractor to complete such Make-Ready Work at a cost and/or time that is materially less than that estimated by Bell Atlantic, Bell Atlantic agrees to use such subcontractor to perform the Make-Ready Work. Bell Atlantic shall use commercially reasonable efforts to provide written notice to existing attachers or occupiers of the affected structures or property of the proposed Make-Ready Work within ten (10) days after receipt of MCIIm's authorization to perform such work. Such attachers or occupiers will be given sixty (60) days after such notice to indicate whether they desire to participate in the proposed modification or expansion.

8.4 If approved by MCIIm, Make-Ready Work will be initiated by Bell Atlantic no earlier than sixty (60) days after notice to existing attachers or occupiers, and Bell Atlantic shall use commercially reasonable efforts to complete such work as soon as practicable.

thereafter, depending upon the size of the job and the cooperation of necessary third parties. MCI shall pay Bell Atlantic for all Make-Ready Work performed by it in accordance with the provisions of this Agreement, and make arrangements with attachers or occupiers participating in the modification or expansion (including Bell Atlantic, if applicable), and with future attachers or occupiers who benefit from the modification or expansion, to reimburse MCI for their share of the make ready costs as required by Applicable Law.

Section 9. Construction, Maintenance and Removal of Communications Facilities

9.1 MCI shall, at its own expense, construct and maintain its Communications Facilities on Poles or in Conduits or Rights of Way covered by this Attachment VI, in a safe condition and in a manner acceptable to Bell Atlantic, so as not to physically conflict or electrically interfere with the facilities attached thereon or placed therein by Bell Atlantic or other authorized licensees.

9.2 Bell Atlantic shall specify the point of attachment on each Pole to be occupied by MCI's Communications Facilities. Where communications facilities of more than one licensee are involved, Bell Atlantic will attempt, to the extent practical, to designate the same relative position on each Pole for MCI's Communications Facilities.

9.3 Subject to Section 9.10 of this Attachment VI, MCI shall secure Bell Atlantic's written consent, not to be unreasonably withheld or delayed, before adding to, relocating, replacing or otherwise modifying its facilities attached to a Pole where additional space or holding capacity may be required on either a temporary or permanent basis. No such modifications shall be made by MCI that would affect the placement or operations of attachments of Bell Atlantic or existing licensees, except through application to Bell Atlantic in accordance with the provisions of Sections 7 and 8 of this Attachment VI.

9.4 MCI must obtain prior written authorization from Bell Atlantic approving the work and the party performing such work before MCI shall install, remove, or provide maintenance of its Communications Facilities in any of Bell Atlantic's Conduit Systems. Bell Atlantic shall not withhold such authorization without good cause.

9.5 In each instance where MCI's Communications Facilities are to be placed in Bell Atlantic's Conduits, MCI and Bell Atlantic shall discuss the placement of MCI's Communications Facilities. Bell Atlantic shall designate the particular Duct(s) to be occupied, the location and manner in which MCI's Communications Facilities will enter and exit Bell Atlantic's Conduit System, and the specific location and manner of installation for any associated equipment which is permitted by Bell Atlantic to occupy the Conduit System. Bell Atlantic will attempt, to the extent practicable and consistent with its non-discrimination obligations, to designate the same relative position in each Conduit bank for each MCI facility.

9.6 Whenever Bell Atlantic intends to modify or alter any Poles, Conduits or Rights of Way which contain MCI's facilities, Bell Atlantic shall provide written notification to MCI at least sixty (60) days prior to taking such action so that MCI may have a reasonable opportunity to add to or modify MCI's facilities. If MCI adds to or modifies MCI's facilities according to this paragraph, MCI shall bear a proportionate share of the costs incurred by Bell Atlantic in making such facilities accessible in accordance with Applicable Law.

9.7 MCI shall be notified in writing at least sixty (60) days prior to any modification that will result in the rearrangement or replacement of its facilities. Subject to Section 9.6 above, MCI shall not be required to bear any of the costs of rearranging or replacing its facilities, if such rearrangement or replacement is required as a result of an additional attachment or the modification of an existing attachment sought by any entity other than MCI, including Bell Atlantic. MCI agrees to make such rearrangements or replacements that are reasonably requested by Bell Atlantic to accommodate the attachment or placement of the facilities of other licensees on the applicable structures.

9.8 Bell Atlantic shall not attach, nor permit other entities to attach facilities on, within or overlashed to existing MCI facilities without MCI's prior written consent.

9.9 Bell Atlantic's Manholes shall be opened only as permitted by Bell Atlantic's authorized employees or agents. MCI shall be responsible for obtaining any necessary authorization from appropriate authorities to open Manholes and conduct work operations therein. Except in emergency situations provided that MCI makes reasonable efforts to give prior notice to Bell Atlantic, MCI's employees, agents or contractors will be permitted to enter or work in Bell Atlantic's Manholes only when an authorized employee or agent of Bell Atlantic is present or prior written authorization waiving this requirement is granted by the Bell Atlantic. Bell Atlantic's said employee or agent shall have the authority to suspend MCI's work operations in and around Bell Atlantic's Manholes if, in the reasonable judgment of said employee or agent any hazardous conditions arise or any unsafe practices are being followed by MCI's employees, agents, or contractors. MCI agrees to pay Bell Atlantic the charges, as determined in accordance with the terms and conditions of Appendix I of this Attachment VI, for having one Bell Atlantic employee or agent present when MCI's work is being done in and around Bell Atlantic's Manholes. The presence of Bell Atlantic's authorized employee or agent shall not relieve MCI of its responsibility to conduct all of its work operations in and around Bell Atlantic's Manholes in a safe and workman-like manner, in accordance with the terms of this Agreement.

9.10 Bell Atlantic shall maintain its Poles, Conduits and Rights of Way without additional charge to MCI beyond the charges provided for in this Attachment VI. MCI shall maintain its own facilities installed on or within Bell Atlantic's Poles, Conduits and Rights of Way at its sole cost. In the event of an emergency, Bell Atlantic shall use commercially reasonable efforts to begin repair of its structures containing MCI's facilities within two (2) hours of notification by MCI. If Bell Atlantic cannot

begin repair within such two (2) hour period, MCI may, using qualified personnel and reasonable care, begin such repairs without the presence of Bell Atlantic personnel. MCI may climb Poles and enter the Manholes, handholes, Conduits and equipment spaces containing Bell Atlantic's facilities in order to perform such emergency maintenance, but only until such time as qualified personnel of Bell Atlantic arrives ready to continue such repairs. For emergency and non-emergency repairs, MCI may use spare Innerduct or Conduits, including the Innerduct or Conduit designated by Bell Atlantic as emergency spare for maintenance purposes; however, MCI may only use such spare Conduit or Innerduct until its repairs are completed but in no event for a period of greater than ninety (90) days, and shall terminate any non-emergency use immediately upon notification of an emergency warranting the use of such spare by Bell Atlantic or other licensees. The Parties agree to cooperate with one another with respect to the use of spare Innerduct or Conduit during any emergency affecting MCI, Bell Atlantic or other licensees.

9.11 Upon reasonable request, Bell Atlantic will provide MCI with space in its Manholes for racking and storage of cable and other materials of the type that Bell Atlantic stores in its Manholes.

9.12 MCI contracting with Bell Atlantic or a contractor approved by Bell Atlantic, shall be permitted to add Conduit parts to Bell Atlantic's manholes or to add branches to Conduits when existing Conduits do not provide the connectivity required by MCI, provided that the structural integrity of the manhole is maintained and sound engineering judgment is employed.

9.13 If practicable and if additional space is required, Bell Atlantic shall within a reasonable period of time remove any retired cable from Poles or Conduit Systems to allow for the efficient use of Poles or Conduit space. Bell Atlantic will give MCI prior notice of its cable removal effort and MCI may have a representative present.

9.14 MCI, at its expense, will remove its Communications Facilities from Poles, Conduits or Rights of Way within sixty (60) days after:

9.14.1 Termination of the license covering such attachment or Conduit Occupancy in accordance with the terms of this Agreement; or

9.14.2 The date MCI replaces its existing facilities on a Pole with the placement of substitute facilities on the same Pole or another Pole or replaces its existing facilities in one Duct with the placement of substitute facilities in another Duct.

9.15 MCI shall remain liable for, and pay to Bell Atlantic, all fees and charges pursuant to provisions of this Agreement until all of MCI's facilities are physically removed from such Poles, Conduits or Rights of Way. If MCI fails to remove its facilities within the specified period, Bell Atlantic shall have the right to remove such

facilities at MCI's expense and without any liability on the part of Bell Atlantic for damage to such facilities unless caused by the negligent or intentional acts of Bell Atlantic.

9.16 When MCI's Communications Facilities are removed from a Pole, Conduit or Right of Way, no reattachment to the same Pole, or occupancy of Conduits or Rights of Way, shall be made until:

9.16.1 MCI has first complied with all of the provisions of this Agreement as though no such Pole Attachment or Conduit or Right of Way occupancy had previously been made; and

9.16.2 All outstanding charges due Bell Atlantic for such previous attachment and/or occupancy have been paid in full.

9.17 MCI shall advise Bell Atlantic in writing as to the date on which the removal of its Communications Facilities from each Pole, Conduit or Right of Way has been completed.

Section 10. Termination of Licenses

10.1 Any license issued under this Agreement shall automatically terminate when MCI ceases to have authority to construct and operate its Communications Facilities on public or private property at the location of the particular Pole, Conduit or Right of Way covered by the license, but shall automatically revive for the balance of any unexpired term upon restoration of such authority within six (6) months of cessation thereof provided MCI pays all applicable charges in the interim period. Notwithstanding the foregoing, MCI shall be allowed to seek a stay or other equitable relief in order to prevent such automatic termination.

10.2 MCI may at any time terminate its license with respect to the attachment to a Pole, or occupancy of a Conduit or Right of Way, and remove its communications facilities by giving Bell Atlantic written notice of such intention (Appendix II, Forms C & D). Once MCI's Communications Facilities have been removed they shall not be reattached to such Pole, or occupy the same portion of such Conduit System or Right of Way, until MCI has complied with all provisions of this Agreement as though no previous license has been issued.

Section 11. Inspection of Licensee's Communications Facilities

11.1 Bell Atlantic reserves the right to make reasonable periodic inspections of any part of MCI's Communications Facilities attached to Poles, or occupying Bell Atlantic's Conduits or Rights of Way, to confirm adherence to the provisions of this Attachment VI.

11.2 Bell Atlantic will give MCI_m advance written notice of such inspections, except in those instances where Bell Atlantic determines that safety considerations justify the need for such an inspection without the delay of waiting until a written notice has been forwarded to MCI_m. In such cases and if practicable, Bell Atlantic shall provide telephonic notice to MCI_m.

11.3 The making of periodic inspections or the failure to do so shall not operate to impose upon Bell Atlantic any liability of any kind whatsoever nor relieve MCI_m of any responsibility, obligations or liability assumed under this Agreement.

Section 12. Unauthorized Attachment, Utilization or Occupancy

12.1 If any of MCI_m's Communications Facilities shall be found attached to Poles, or occupying Conduit or Right of Way, for which no license has been granted, Bell Atlantic without prejudice to its other rights or remedies under this Agreement may require MCI_m to submit an application pursuant to Section 7 of this Attachment within sixty (60) days after receipt of written notification from Bell Atlantic of the unauthorized attachment or occupancy. If such application is not received by Bell Atlantic within the specified time period, MCI_m may be required to remove its unauthorized attachment or occupancy, or Bell Atlantic may, at Bell Atlantic's option, remove MCI_m's facilities at MCI_m's sole expense and risk and without liability to Bell Atlantic. In addition, MCI_m shall pay any unauthorized attachment or occupancy charge as specified in Appendix I of this Attachment.

12.2 No act or failure to act by Bell Atlantic with regard to said unlicensed use shall be deemed as a ratification of the unlicensed use; and if any license should be subsequently issued, said license shall not operate retroactively or constitute a waiver by Bell Atlantic of any of its rights or privileges under this Agreement or otherwise; provided, however, that MCI_m shall be subject to all liabilities, obligations and responsibilities of this Agreement in regard to said unauthorized use from its inception.

Section 13. Security Interest

At such time that MCI_m's Net Worth fails to exceed \$100,000,000, MCI_m shall grant Bell Atlantic a security interest in all of MCI_m's Communications Facilities now or hereafter attached to Poles, or placed in Conduit Systems or Rights of Way pursuant to this Agreement, and MCI_m agrees to perform all acts necessary to perfect Bell Atlantic's security interest under the terms of the Uniform Commercial Code, or applicable lien or security laws then in effect. If the terms of MCI_m's loan agreements and debentures preclude the grant of liens or security interests to Bell Atlantic, MCI_m shall grant to Bell Atlantic, upon Bell Atlantic's request, other permissible assurance of security for performance, satisfactory to Bell Atlantic, to cover any amounts due Bell Atlantic under this Agreement. Nothing in this Section shall operate to prevent Bell Atlantic from pursuing, at its option, any other remedies under this Agreement or in law or equity, including public or private sale of facilities under security interest or lien.

Section 14. Liability and Damages

14.1 Bell Atlantic shall exercise reasonable caution to avoid damaging MCI_m Communications Facilities and shall make an immediate report to MCI_m of the occurrence of any such damage caused by its employees, agents or contractors, and Bell Atlantic assumes all responsibility for any and all direct loss from such damage caused by Bell Atlantic's employees, agents or contractors. Bell Atlantic shall not be liable to MCI_m for any interruption of MCI_m's service or for interference with the operation of MCI_m's Communications Facilities.

14.2 MCI_m shall exercise reasonable caution to avoid damaging the facilities of Bell Atlantic and of others attached to Poles, or occupying Conduits or Rights of Way, and shall make an immediate report to the owner of facilities so damaged and MCI_m assumes all responsibility for any and all direct loss from such damage caused by MCI_m's employees, agents or contractors. MCI_m shall not be liable to Bell Atlantic for any interruption of Bell Atlantic's service or for interference with the operation of Bell Atlantic's communications facilities.

14.3 MCI_m shall promptly advise Bell Atlantic of all claims relating to damage of property or injury to or death of persons, arising or alleged to have arisen in any manner by the erection, maintenance, repair, replacement, presence, use or removal of MCI_m's facilities. Copies of all accident reports and statements made to MCI_m's insurer by MCI_m or others shall be furnished promptly to Bell Atlantic. Similarly, Bell Atlantic shall promptly advise MCI_m of all claims relating to damage of property or injury to or death of persons, arising or alleged to have arisen in any manner by the erection, maintenance, repair, replacement, presence, use or removal of Bell Atlantic's facilities where MCI_m Communication Facilities are involved in such claim. Copies of all related accident reports and statements made to Bell Atlantic's insurer by Bell Atlantic or others shall be furnished promptly to MCI_m.

14.4 Except as expressly provided in this Attachment VI, the Parties indemnification and liability obligations with respect to the use of Poles, Conduits and Rights of Way shall be as provided for in Part A of the Agreement.

Section 15. Insurance

15.1 MCI_m shall obtain and maintain insurance issued by an insurance carrier authorized to conduct business in Bell Atlantic's operating region and having an A.M. Best rating of not less than A-VII to protect Bell Atlantic and other authorized user of transport structures from and against all claims, demands, causes of actions, judgments, costs, including attorneys' fees, expenses and liabilities of every kind and nature which may arise or result from or by reason of any negligent or wrongful act of MCI_m related to activities covered by this Attachment VI.

15.2 The amounts of such insurance:

15.2.1 against liability due to damage to property shall be not less than \$2,000,000 as to any one occurrence and \$2,000,000 aggregate, and

15.2.2 against liability due to injury or death of persons shall be not less than \$2,000,000 as to any one person and \$2,000,000 as to any one occurrence.

15.3 MCI shall name Bell Atlantic as an additional insured and shall provide certificates by each company insuring MCI to the effect that it has insured MCI for all liabilities of MCI covered by this Agreement and that it will not cancel any such policy of insurance issued to MCI except after thirty (30) days written notice to Bell Atlantic.

15.4 All insurance required in accordance with Subsections 15.1 and 15.2 above must be effective before Bell Atlantic will authorize attachment to a Pole, or occupancy of Conduit or Rights of Way, and shall remain in force until such MCI's facilities have been removed from all such Poles, Conduits or Rights of Way. In the event that MCI shall fail to maintain the required insurance coverage, Bell Atlantic may pay any premium thereon falling due, and MCI shall forthwith reimburse Bell Atlantic for any such premium paid.

15.5 Notwithstanding the foregoing, if MCI's net worth exceeds \$100,000,000, MCI may elect to self-insure in lieu of obtaining any of the insurance required by this Section 15. If MCI self-insures, MCI shall furnish to Bell Atlantic, and keep current, evidence of such net worth. If MCI self-insures, MCI shall release, indemnify, defend, and hold Bell Atlantic harmless against all losses, costs (including reasonable attorney's fees), damages, and liabilities resulting from claims that would otherwise have been covered by the foregoing insurance requirements (including without limitation claims alleging negligence or breach of contract).

Section 16. Authorization Not Exclusive

Nothing herein contained shall be construed as a grant of any exclusive authorization, right or privilege to MCI. Subject to the provisions of this Agreement, Bell Atlantic shall have the right to grant, renew and extend rights and privileges in a Non-Discriminatory manner to others not parties to this Agreement, by contract or otherwise, to use any Pole, Conduit or Right of Way covered by this Attachment VI.

Section 17. Assignment of Licenses

MCI shall not assign or transfer any license or any authorization granted under this Attachment VI, and such licenses shall not inure to the benefit of MCI's successors or assigns, without the prior written consent of Bell Atlantic unless such transfer of rights is made pursuant to an assignment of this Agreement pursuant to the provisions of Part A, Section 5 (Assignment). Bell Atlantic shall not unreasonably withhold such consent. In the event such consent or

consents are granted by Bell Atlantic, then prior to such assignment becoming effective the assignee shall be required to execute Bell Atlantic's generally available license agreement covering the affected licenses.

Section 18. Additional Terminations

18.1 Subject to provisions of Section 17 of this Attachment, should MCIIm cease to provide its Telecommunications Services in or through the area covered by any license under this Attachment VI on other than a demonstrably temporary basis not to exceed six (6) months, then MCIIm's rights, privileges and authorizations under any such license issued hereunder shall automatically terminate as of the date following the final day that such Telecommunications Services are provided.

18.2 Subject to Section 18.3 below and the Force Majeure provisions of Part A of the Agreement, Bell Atlantic shall have the right to terminate any license issued hereunder whenever MCIIm is in default of any material term of this Agreement, including, but not limited to, the following conditions, as applicable to the affected facilities:

18.2.1 If MCIIm uses its Communications Facilities or maintains such facilities in violation of any Applicable Law or in aid of any unlawful act or undertaking; or

18.2.2 Subject to Section 10.1 of this Attachment, if any authorization which may be required of MCIIm by any governmental or private authority for the construction, operation, and maintenance of MCIIm's Communications Facilities is denied or revoked; or

18.2.3 If MCIIm's insurance carrier shall at any time notify Bell Atlantic or MCIIm that the policy or policies of insurance, required under Section 15 hereof, will be canceled or if Bell Atlantic reasonably determines that the requirements of Section 15 of this Attachment will no longer be satisfied.

18.3 Bell Atlantic will promptly notify MCIIm in writing of any condition(s) applicable to 18.1 and 18.2 above specifying the license and facilities in question. MCIIm shall take immediate corrective action to eliminate any such condition(s) and shall confirm in writing to Bell Atlantic within thirty (30) days following receipt of such written notice that the cited condition(s) has ceased or been corrected. If MCIIm fails to discontinue or correct such condition(s) and fails to give the required confirmation, Bell Atlantic shall so notify MCIIm and thereafter may immediately terminate MCIIm's licenses for the affected facilities under this Attachment VI. Notwithstanding the foregoing, in the event that such corrective action is incapable of correction within thirty (30) days, MCIIm shall initiate such corrective action within the thirty (30) day period referred to above and shall be allowed a reasonable time to complete such correction before MCIIm is considered in default under this Section 18. MCIIm shall use its best efforts to complete such correction as soon as possible.

18.4 In the event of termination of this Agreement, MCI shall remove its Communications Facilities from the affected Poles, Conduits and Rights of Way within six (6) months from the date of such termination; provided, however, that MCI shall be liable for and pay all fees and charges pursuant to terms of this Attachment VI to Bell Atlantic until MCI's Communications Facilities are actually removed from Bell Atlantic's Poles, Conduits and Rights of Way.

18.5 If MCI does not remove its Communications Facilities from Bell Atlantic's Poles, Conduits and Rights of Way within the applicable time periods specified in this Attachment VI, Bell Atlantic shall have the right to remove them at the expense of MCI and without any liability on the part of Bell Atlantic to MCI therefor.

Section 19. Term of Licenses

19.1 All licenses issued hereunder shall continue in effect until the Agreement expires or is terminated, unless earlier terminated by MCI in accordance with this Attachment VI.

19.2 Termination of licenses shall not affect MCI's liabilities and obligations incurred with respect thereto prior to the Effective Date of such termination.

- APPENDIX I

SCHEDULE OF FEES AND CHARGES

THIS APPENDIX I, effective as of _____, is an integral part of the License Agreement between Bell Atlantic - Pennsylvania, Inc. (Bell Atlantic) and MCI Metro Access Transmission Services LLC (MCI m), dated _____ and contains the fees and charges governing the use of Bell Atlantic's Poles, Conduits and Rights of Way by MCI m's Communications Facilities.

1. Attachment, Utilization, and Occupancy Fees

1.1 General

- a) Attachment, utilization, and occupancy fees commence on the date set forth in Section 7.5 of the License Agreement. Subject to clause c) below, such fees cease as of the final day on which the attachment or occupancy is physically removed or is discontinued.
- b) A one (1) month minimum charge is applicable for all attachment and occupancy accommodations.
- c) Fees shall be payable semi-annually in advance on the first day of January and July. No fees shall be refunded for any licenses terminated and attachments or occupancies removed during any period for which such advance payments have been made.
- d) The total attachment, and occupancy fees due hereunder, shall be based upon the number of Poles and Duct feet of Conduit for which licenses have been issued before the first day of January and the first day of July each year. Each semi-annual payment shall include a proration of the monthly attachment and occupancy charges applicable for attachments, or occupancy initially authorized by Bell Atlantic during the preceding six (6) month period. Any such fees shall be computed in accordance with Applicable Law.

2. Fees

2.1 Application and Engineering Survey Fee

- a) Per Pole attached \$
- b) Per Manhole/per Duct run \$
- c) Right of Way (determined on a case by case basis)

2.2 Annual Fee

- a) Horizontal Attachment
Per attachment \$
- b) Vertical Attachment
Per Pole attached (\$/Vertical foot of occupancy) \$
- c) Per foot of cable placed in the
Conduit \$
- d) Right of Way (determined on a case by case basis as mutually agreed by the parties)

2.3 Other Charges

Computation

Charges for all work performed by Bell Atlantic or by its authorized representative in connection with the furnishing of Pole, Conduit and Right of Way accommodations as covered by this Agreement shall be based upon the cost to Bell Atlantic for performance of such work in accordance with Applicable Law, if any. Such charges will apply for, but not be limited to, Prelicense Survey; Make-Ready Work; inspection and removal of MCI's Communications Facilities, where applicable; and supervision by one (1) employee, at the option of the Bell Atlantic, of MCI-performed work in and around the immediate vicinity of a Conduit System limited to one (1) employee.

2.4 In the event that it is determined that MCI has made attachment in or on any Pole, Conduit or Right of Way of Bell Atlantic for which a License has not been executed, MCI shall be obliged to: a) apply for such license immediately; and b) pay to Bell Atlantic fees for said attachment for the entire period of time which can be reasonably established as the date of MCI's attachment, but in no case less than one (1) year prior to date of discovery.

APPENDIX II

ADMINISTRATIVE FORMS AND NOTICES

THIS APPENDIX II, effective as of _____, is an integral part of the License Agreement between Bell Atlantic - Pennsylvania, Inc. (Bell Atlantic), and MCI Metro Access Transmission Services LLC (MCIm), dated _____ and contains the administrative forms governing the use of Bell Atlantic's Poles and Conduit by MCIm's Communications Facilities.

INDEX OF ADMINISTRATIVE FORMS

Application and Pole Attachment License

A-1

Pole Details

A-2

Application and Conduit Occupancy License

B-1

Conduit System Diagram

B-2

Cable to occupy Conduit and Equipment to be placed in Manholes

B-3

Authorization for Make-Ready Work

B-4

Notification of Removal of Pole Attachments

C

Notification of Removal of Conduit Occupancy

D

APPLICATION AND POLE ATTACHMENT LICENSE

Bell Atlantic - Pennsylvania, Inc.

In accordance with the terms and conditions of the License Agreement between us, dated _____, 19____, application is hereby made for a nonexclusive license to attach communication facilities to _____ Poles as indicated on Form A-2. This request will be designated:

Pole Application # _____

Enclosed is a check in the amount of \$ _____ to cover the cost of the Pre-License Survey. (Appendix I)

MCIIm: _____

Signed: _____

Dated: _____

Tel. No: _____

.....
Permission is hereby granted to attach communication facilities to _____ Poles as indicated on the attached Form A-2.

Atlantic)

Bell Atlantic - Pennsylvania, Inc. (Bell

Signed: _____

Dated: _____

Tel. No: _____

Applications shall be numbered in sequential ascending order by MCIIm. Bell Atlantic will process applications in ascending order according to the applications numbers assigned by MCIIm.

(MCI_m)

(Central Office Area)

(Pole Application #)

POLE DETAILS

| Location Pole # | | | | | | |
|--------------------|--|--|--|--|--|--|
| 1 | | | | | | |
| 2 | | | | | | |
| 3 | | | | | | |
| 4 | | | | | | |
| 5 | | | | | | |
| 6 | | | | | | |
| 7 | | | | | | |
| 8 | | | | | | |
| 9 | | | | | | |
| 10 | | | | | | |
| 11 | | | | | | |
| 12 | | | | | | |
| 13 | | | | | | |
| 14 | | | | | | |
| 15 | | | | | | |

APPLICATION AND CONDUIT OCCUPANCY LICENSE

Bell Atlantic - Pennsylvania, Inc.

In accordance with the terms and conditions of the License Agreement between us, dated _____, 19____, application is hereby made for a license to occupy the Conduit system shown on Form B-2, with the cable and equipment detailed on Forms B-3 and B-4. This request will be designated:

Conduit Application # _____

Enclosed is a check in the amount of \$ _____ to cover the cost of the Pre-License Survey. (Appendix I)

(MCI_m)

Signed: _____

Dated: _____

Tel. No: _____

.....
Permission is hereby granted to occupy Bell Atlantic's Conduit system, as indicated on the attached Form B-2, with cable equipment and facilities specified on the attached Forms B-3. The Duct footage for this License is _____

Bell Atlantic - Pennsylvania, Inc.

(Bell Atlantic)

Signed: _____

Dated: _____

Tel. No: _____

Applications shall be numbered in sequential ascending order by MCI_m. Bell Atlantic will process applications in ascending order according to the applications numbers assigned by MCI_m.

(MCI_m)

(Area)

(Conduit Application #)

SAMPLE CONDUIT SYSTEM DIAGRAM

CONDUIT SYSTEM DIAGRAM

(MCI m)

(Area)

(Conduit Application #)

CABLE TO OCCUPY CONDUIT

| | Cable Type | | Quantity | Notes |
|---|------------|--|----------|-------|
| 1 | | | | |
| 2 | | | | |
| 3 | | | | |
| 4 | | | | |
| 5 | | | | |

EQUIPMENT TO BE PLACED IN MANHOLES

| | Equipment | Width | Depth |
|---|-----------|-------|-------|
| 1 | | | |
| 2 | | | |
| 3 | | | |
| 4 | | | |
| 5 | | | |

AUTHORIZATION FOR MAKE-READY WORK

Following is a summary of the estimated charges for the following application:

Pole attachment application number _____
 or
 Conduit occupancy application number _____
 or
 Right of Way occupancy application number _____
 Estimated cost \$ _____

Note that in the event that an advance payment is required, actual costs will be billed at the conclusion of the work.

(Bell Atlantic)

By: _____
(Signature of authorized person)

Its: _____
(Title of authorized person)

Date: _____

Telephone Number: _____

Order Number: _____

I hereby acknowledge and agree to pay all charges, as above, and authorize work to begin.

(MCI/m)

By: _____
(Signature of authorized person)

Its: _____
(Title of authorized person)

Date: _____

Telephone Number: _____

NOTIFICATION OF REMOVAL OF POLE ATTACHMENTS

In accordance with the terms and conditions of the License Agreement between us, dated _____, 19____, notice is hereby given that the following Pole attachments have been removed.

| Attachment | Location | Location | Date Removed |
|------------|----------|----------|--------------|
| | | | |
| | | | |
| | | | |
| | | | |
| | | | |
| 6 | | | |
| 7 | | | |
| 8 | | | |
| | | | |
| 10 | | | |

SUBMITTED:

APPROVED:

(MCI)

Bell Atlantic - Pennsylvania, Inc.
(Bell Atlantic)

Signed: _____

Signed: _____

Dated: _____

Dated: _____

NOTIFICATION OF REMOVAL OF CONDUIT OCCUPANCY

In accordance with the terms and conditions of the License Agreement between us, dated _____, 19____, notice is hereby given that the occupancy of the following Conduit has been removed.

| | Conduit Location | Conduit Application | Date Removed |
|----|------------------|---------------------|--------------|
| 1 | | | |
| 2 | | | |
| 3 | | | |
| 4 | | | |
| 5 | | | |
| 6 | | | |
| 7 | | | |
| 8 | | | |
| 9 | | | |
| 10 | | | |

SUBMITTED:

APPROVED:

(MCI)

Bell Atlantic - Pennsylvania, Inc.
(Bell Atlantic)

Signed: _____

Signed: _____

Dated: _____

Dated: _____