

**BEFORE THE
PUBLIC UTILITY COMMISSION**

In Re: Meghan Flynn, Rosemary Fuller,	:	
Michael Walsh, Nancy Harkins, Gerald	:	Docket No. C-2018-3006116
McMullen, Caroline Hughes, and	:	
Melissa Haines,	:	
Petitioner	:	
	:	
v.	:	
	:	
Sunoco Pipeline, L.P.,	:	
Respondent	:	

**PETITION TO INTERVENE OF THE
TWIN VALLEY SCHOOL DISTRICT, BERKS COUNTY, PENNSYLVANIA**

Pursuant to 52 Pa. Code §§5.71-5.75, the Twin Valley School District, Berks County, Pennsylvania (“the School District”) hereby petitions to intervene in the above-captioned proceeding. In support thereof, the School District submits as follows:

A. THE SCHOOL DISTRICT

1. The School District is a school district of the third class with an address of 4851 North Twin Valley Road, Elverson, Berks County, Pennsylvania, and a telephone number of 610-286-8611.
2. The School District and the municipalities it serves are located partly in Berks County and partly in Chester County, Pennsylvania.
3. The School District currently operates a high school, a middle school, and three elementary schools (“the District Schools”). The School District is one of the largest geographically diverse school districts in Berks and Chester Counties.
4. The School District Schools service the attendance areas of Elverson Borough, Honey Brook Borough, Honey Brook Township, Robeson Township, West

Nantmeal Township, New Morgan Borough, and Caernarvon Township, and as of January, 2019, had a student enrollment of approximately 3,300 students.

5. The School District, as a school district of the third class, is governed, *inter alia*, by the Pennsylvania Public School Code of 1949, 24 P.S. §1-101 *et seq.*
6. The School District's attorneys in this matter are:

Leah Rotenberg, Esquire
PA I.D. #203690
Mays, Connard & Rotenberg LLP
1235 Penn Avenue, Suite 202
Wyomissing, PA 19610
610-400-0481
rotenberg@mcr-attorneys.com

7. The School District petitions to intervene in the above-captioned proceeding.
8. The School District requests to receive all documents electronically to the above-listed email address as allowed by 52 Pa. Code §1.54(b)(3).

B. THE ABOVE-CAPTIONED PROCEEDING

1. On November 19, 2018, Petitioners/Complainants Meghan Flynn, Rosemary Fuller, Michael Walsh, Nancy Harkins Gerald McMullen, Caroline Hughes, and Melissa Haines (collectively the "Flynn Complainants") filed a Complaint against Respondent Sunoco Pipeline, L.P. ("Sunoco") at Docket No. C-2018-3006116 and, concurrently therewith, a Petition for Interim Emergency Relief against Sunoco at Docket No. P-2018-3006117, which have been consolidated.¹

¹ On December 11, 2018, Administrative Law Judge Elizabeth Barnes issued an Order denying relief to the Flynn Complainants that would affect the temporary cessation of operations of ME1 and construction of the ME2 work-around pipeline and certified that Order to the Commission.

2. **The Flynn Complainants averred that properties in Chester and Delaware Counties were in close proximity to the Mariner East 1 (“ME1) pipeline and/or a work-around 12-inch diameter pipeline that circumvents stopped construction on the Mariner East 2 (“ME2”) and Mariner East 2X (ME2X).² At times, these Sunoco pipelines are referred to collectively as “the ME Pipelines.”**
3. **The Flynn Complainants also averred that ME1, MED2, ME2X and the work-around pipelines carrying or intended to carry HVLs are inherently dangerous and due to their location in Chester and Delaware Counties (high consequence areas), a pipeline rupture there would be catastrophic.**
4. **The Flynn Complainants further contend that ME1 is being operated and the work-around pipeline is about to be operated without an adequate public awareness program, emergency notification system, or credible emergency management plan in violation of 49 CFR §195.440. The Flynn Complainants contend that Sunoco is violating 49 CFR §195.248 in that ME1 and the work-around pipeline are located within 50 feet of private dwellings or industrial buildings or places of public assembly without at least four feet of cover.**
5. **The Flynn Complainants’ three-count Complaint requested that the Commission enter an Order directing Sunoco permanently to (a) cease operation of the 8-inch ME1 pipeline; (b) cease operation of the work-around pipeline, ME2, and ME2X; and (c) grant such other and further relief as may be appropriate.**

² ME1 is currently operational. ME2 and ME2X are not currently operational. The work-around 12-inch pipeline is a 1930s era pipeline that had been carrying petroleum products such as gasoline until Sunoco repurposed it to connect to ME2 in order to carry highly volatile liquids (HVLs).

C. THE SCHOOL DISTRICT'S INTEREST IN INTERVENTION

- 1. The School District has at least three schools located in close proximity to the various pipelines identified above, all within the "blast zone," which might extend to more than 2,000 feet from the ME Pipelines. In addition to buildings and classrooms, these schools have playing fields, playgrounds and other facilities which are places of public assembly and which are used and enjoyed by the community in general.**
- 2. The right-of-way containing the 12" non-HVL pipeline which is temporarily transporting HVL's as part of the Mariner East work-around is approximately:**
 - a. 392 feet away from Twin Valley Elementary School (see Google Map attached as Exhibit A);**
 - b. 433 feet away from Twin Valley High School (see map attached as Exhibit B); and**
 - c. 566 feet away from Twin Valley Middle School.**
- 3. The School District has a direct, substantial and immediate interest in this matter related to its obligation to educate its students and to protect the health, safety, and welfare of its students, staff, and users of the School District facilities, that is unique, and not represented by any other party in the proceeding in which the ME Pipelines are physically located. 52 Pa. Code §69.1101.**
- 4. The School District has a direct, substantial, and immediate interest in this proceeding as a municipal entity obligated under the Pennsylvania Public School Code of 1949, 24 P.S. §1-101 *et seq.*, to promote the education, health, safety, and**

welfare of the School District's children and to assure the proper operation of the schools, including disaster prevention and response.

5. Participation by the School district in this proceeding is in the public interest.
6. No other party to this proceeding possesses an interest identical to that of the School District.
7. The School District possesses a sufficient legal interest in this matter so as to permit the filing of this intervention.
8. The School District's Intervention is timely pursuant to the prescripts of 52 Pa. Code §5.53.

D. REQUESTED RELIEF

1. The School District seeks intervention to request the following relief:
 - a. That the Commission order Sunoco to perform continued and ongoing line inspection and geophysical testing and analysis in the areas of School District's schools where the ME Pipelines are operating and/or are in the process of construction;
 - b. That the Commission order Sunoco to provide to the School District on a timely basis the results of that continued and ongoing line inspection and geophysical testing;
 - c. That the Commission order Sunoco to disclose to the School District when work crews or inspectors will be on or near School District property;
 - d. That the Commission order that in the absence of either the above testing or inspection, or the delivery of the result of same, or in the absence of testing or inspection results that establish that the ME Pipelines or the valve station are

determined by the Bureau of Inspection and Enforcement (“BI&E”) and the U.S. Department of Transportation’s Pipeline and Hazardous Materials Safety Administration (“PHMSA”) to not pose any risk to the School District’s properties, that the ME Pipelines shall immediately cease operations until such time as Sunoco performs all necessary corrective actions and acquires approval of BI&E and PHMSA prior to receiving Commission approval to resume operation and/or construction;

- e. That the Commission order Sunoco to develop and submit testing and inspection protocols appropriate to ensure the safe operation and maintenance of MWE Pipelines in close proximity to School District’s schools, to be approved by BI&E and PHMSA on a regular basis;**
- f. That the Commission order Sunoco to develop and install a mass early warning notification system at all potentially affected School District Schools which would provide immediately notice of a leak, potential explosion or other failure in the pipeline system;**
- g. That the Commission order Sunoco to disclose to the School District any damage or potential damage to School District facilities or property;**
- h. That the Commission order Sunoco provide a School District-specific public education or awareness plan designed to inform and educate the students, families, and School District Staff on proper and effective disaster prevention and response;**
- i. Such further relief as may become available during the proceedings on this Application.**

WHEREFORE, the Twin Valley School District respectfully requests that this Honorable Commission grant this Petition to Intervene, providing the School District with full-party status in this proceeding.

Respectfully submitted,

MAYS, CONNARD & ROTENBERG LLP



Leah Rotenberg, Esquire

Atty. I.D. No. 206390

1235 Penn Avenue, Suite 202

Wyomissing, PA 19610

610-400-0481

rotenberg@mcr-attorneys.com

Attorney for Intervenor

Twin Valley School District

Date: 1/18, 2019

VERIFICATION

I, Dr. Robert F. Pleis, hereby state that I am the Superintendent for the Twin Valley School District, Berks County, Pennsylvania, and that as Superintendent, I am duly authorized to make this Verification on its behalf; and that the facts set forth in the foregoing Petition to Intervene are true and correct to the best of my knowledge, information, and belief. I understand that false statements herein are made subject to the penalties of 18 Pa. C.S. §4904 relating to unsworn falsification to authorities.

Date: 1/18/19, 2019

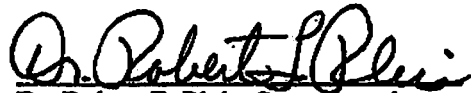
Dr. Robert F. Pleis, Superintendent
Twin Valley School District

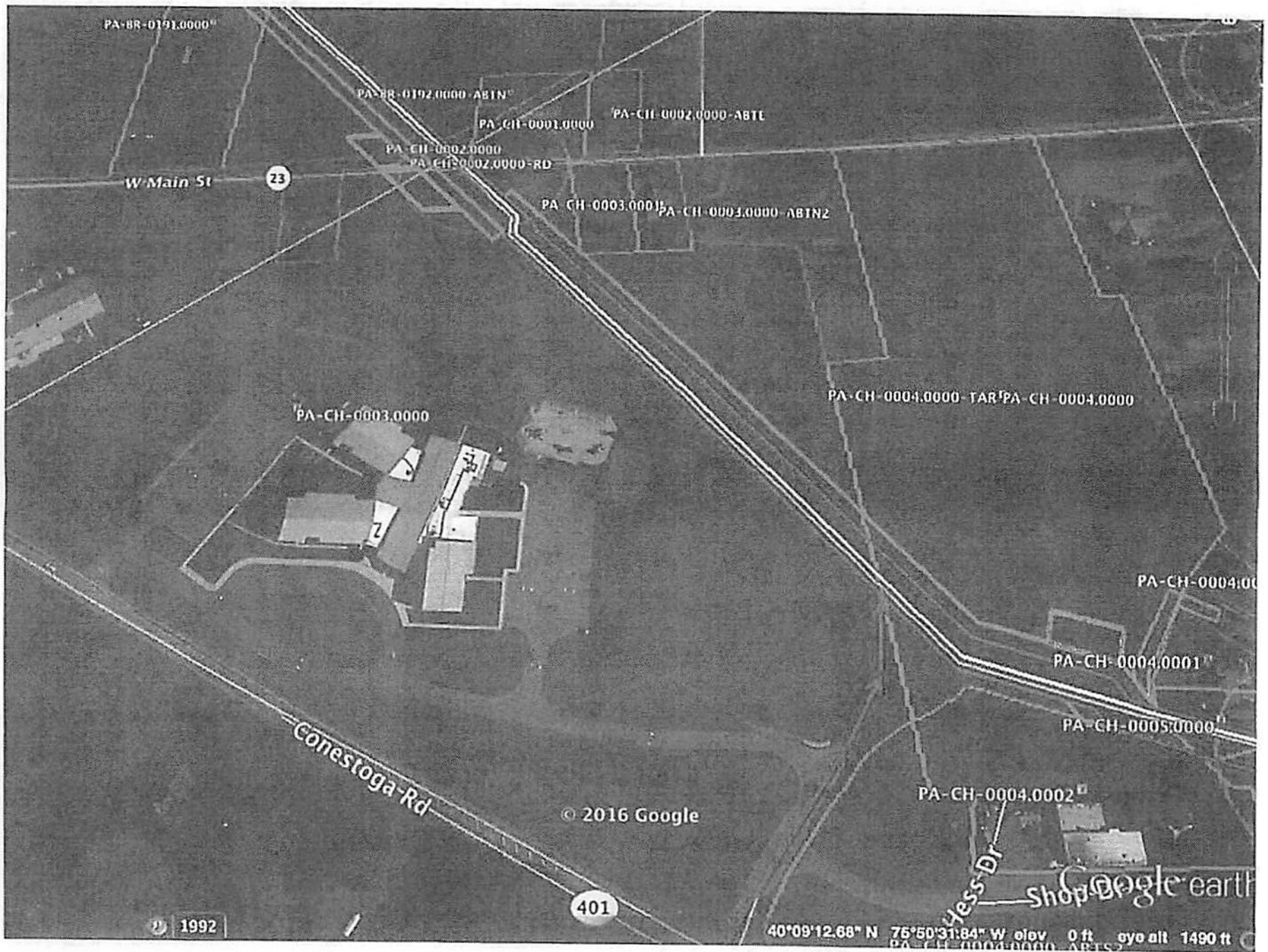
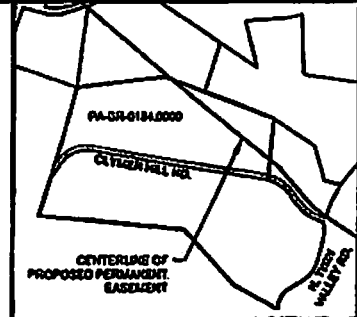
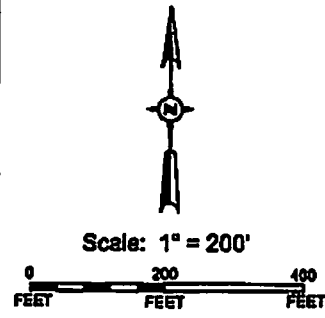

EXHIBIT A

EXHIBIT B CAERNARVON TOWNSHIP BERKS COUNTY, PENNSYLVANIA



VICINITY MAP
NOT TO SCALE



- LEGEND**
- R.O.D.B.C.P.A. BERKS COUNTY RECORDER OF DEEDS, PA.
 - P.O.B. POINT OF BEGINNING
 - P.O.T. POINT OF TERMINATION
 - () RECORD BEARING AND DISTANCE
 - PROPERTY CORNER FOUND
 - PROPERTY CORNER NOT FOUND
 - PROPOSED PIPELINE/DEED LINE INTERSECTION
 - PROPOSED PIPELINE VERTICE
 - ▨ PROPOSED PERMANENT EASEMENT
 - ▨ PROPOSED TEMPORARY WORK SPACE
 - ▨ PROPOSED ADDITIONAL TEMPORARY WORK SPACE

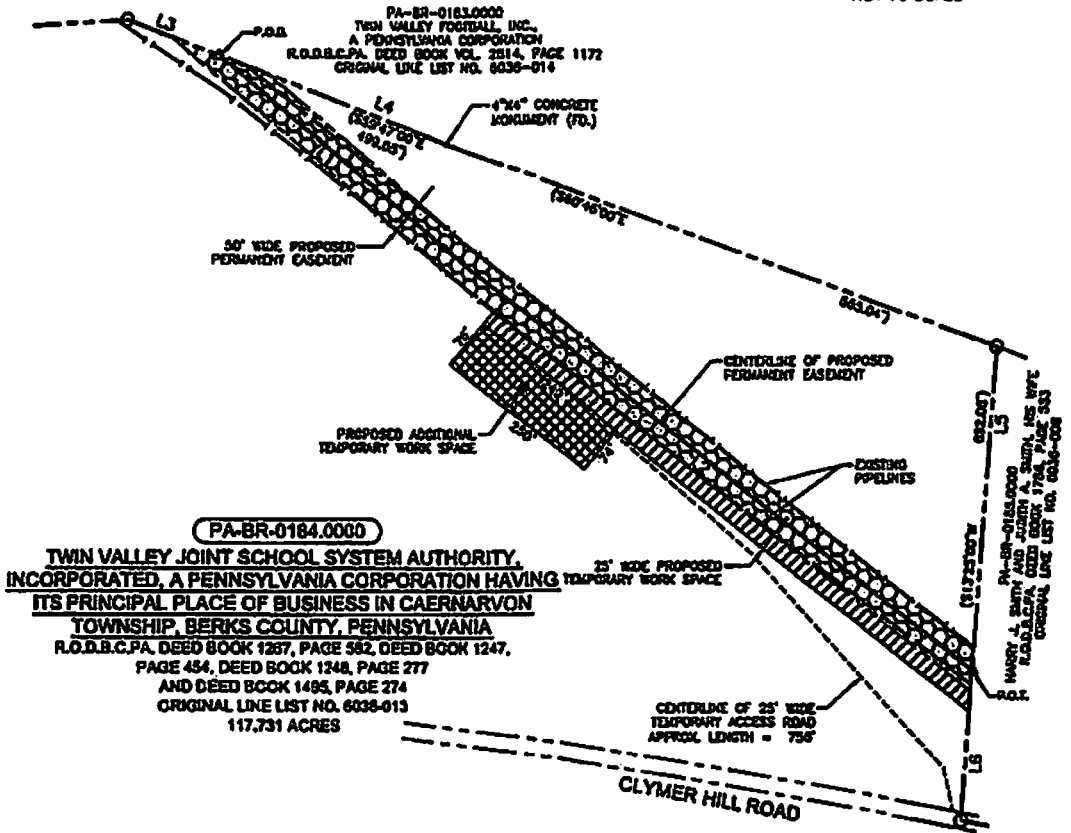

TOTAL DISTANCE ACROSS PROPERTY: 1428.21 FT
PROPOSED PERMANENT EASEMENT: 1.84 ACRES
TEMPORARY WORK SPACE: 0.52 ACRES
ADDITIONAL TEMPORARY WORK SPACE: 0.43 ACRES

LINE	BEARING	DISTANCE
L1	S27°54'00\"/>	

- NOTES:**
- THE PURPOSE OF THIS PLAN IS TO SHOW THE LIMITS OF THE PROPOSED PERMANENT AND TEMPORARY EASEMENTS CROSSING THE SUBJECT PROPERTY. THE PROPERTY LINES SHOWN HEREON WERE COMPILED FROM THE BEST AVAILABLE RECORD INFORMATION AND GEO-REFERENCED TO APPARENT BOUNDARY EVIDENCE AND IS NOT THE RESULT OF A BOUNDARY SURVEY.
 - THE INFORMATION SHOWN HEREON IS AN ILLUSTRATION OF THE APPARENT PROPERTY LINES IN RELATION TO THE PROPOSED EASEMENTS. IT SHOULD NOT BE USED AS A PROPERTY BOUNDARY SURVEY.
 - BEARINGS SHOWN HEREON ARE GRID BEARINGS OF MASS PENNSYLVANIA STATE PLANE SOUTH ZONE, U.S. SURVEY FEET. SURVEYED DISTANCES SHOWN HEREON ARE ON GRID AND A SCALE FACTOR MUST BE APPLIED TO CONVERT TO GROUND DISTANCES.
 - CORNER TIES WITH "A" REFERENCE, ARE APPROXIMATE SCALED DISTANCES.
 - THE PROPOSED PIPELINE WILL BE CONSTRUCTED GENERALLY 20' FROM THE EXISTING MARKER EAST 1 PIPELINE.
 - FOR ADDITIONAL INFORMATION, SEE ATTACHED LEGAL DESCRIPTION (219-4871 'A') MADE IN CONNECTION WITH AND CONSIDERED AN INTEGRAL PART OF THE ABOVE DESCRIBED EASEMENT.
 - EXISTING PIPELINE INFORMATION HAS BEEN PROVIDED BY KOONEY ENGINEERING.

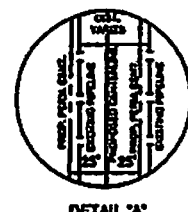

DESIGNED BY: **LW Survey Co.**
 17255 Oregon Pike
 Suite 104
 Lancaster, PA 17601

CLIENT: **Sunoco Pipeline L.P.**

NO.	DATE	BY	DESCRIPTION
0	8/5/14	SF	ISSUED FOR REVIEW
1	8/27/14	AMK	REVISED PER RE DATA
2	8/28/14	BTG	REVISED PER COMMENTS
3	10/13/14	ARG	REVISED PER COMMENTS
4	11/10/14	AMK	REVISED PER REHAYA
5	11/25/14	AML	REVISED PER COMMENTS

**PERMANENT EASEMENT & RIGHT OF WAY.
CROSSING PROPERTY OF
TWIN VALLEY JOINT SCHOOL SYSTEM AUTHORITY,
INCORPORATED, A PENNSYLVANIA CORPORATION HAVING ITS PRINCIPAL PLACE
OF BUSINESS IN CAERNARVON TOWNSHIP, BERKS COUNTY, PENNSYLVANIA**

DRAWN BY: SF DRAWN DATE: 8/5/14 CHECKED BY: JPF PLOT DATE: 11/25/14

TRACED NO. **PA-BR-0184.0000** **PAGE 1 OF 1**

**BEFORE THE
PUBLIC UTILITY COMMISSION**

In Re: Meghan Flynn, Rosemary Fuller,	:	
Michael Walsh, Nancy Harkins, Gerald	:	Docket No. C-2018-3006116
McMullen, Caroline Hughes, and	:	
Melissa Haines,	:	
	:	
Petitioner	:	
	:	
v.	:	
	:	
Sunoco Pipeline, L.P.,	:	
	:	
Respondent	:	

CERTIFICATE OF SERVICE

I hereby certify that this day I have served a copy of the Twin Valley School District's Petition for Intervention upon the persons listed below via first class U.S. Mail, postage prepaid, in accordance with the requirements of 52 Pa. Code §1.54 relating to service by a party:

**Thomas J. Sniscak, Esq.
Kevin J. McKeon, Esq.
Whitney E. Snyder, Esq.
Hawk McKeon & Sniscak, LLP
100 North Tenth Street
Harrisburg, PA 17101**

**Michael S. Bomstein, Esq.
Pinnola & Bomstein
Suite 2126 Land Title Building
100 South Broad Street
Philadelphia, PA 19110**

**Anthony D. Kanagy, Esq.
Garrett P. Lent, Esq.
Post & Schell PC
17 North Second St., 12th Flr.
Harrisburg, PA 17101-1601**

**Robert D. Fox, Esq.
Neil S. Witkes, Esq.
Diana A. Silva, Esq.
Manko, Gold, Katcher & Fox, LLP
401 City Ave., Ste. 901
Bala Cynwyd, PA 19004**

Rich Raiders, Esq.
Raiders Law, PC
606 North Fifth St.
Reading, PA 19601

Date: January 18, 2019

Leah Rotenberg, Esquire