

Act 537 Plan Update Special Study

**Turbotville Borough
Northumberland County, Pennsylvania**

April, 2019

Table of Contents

DEP Transmittal Letter

Part 1 – General Information

Part 2 – Administrative Completeness Checklist

1. Table of Contents
2. Plan Summary
 - A. Proposed Service Area and Municipal Facilities Being Acquired
 - B. Chosen Alternative
 - C. Estimated Cost of Implementing Acquisition
 - D. Turbotville Borough and PAWC Commitments
 - E. Implementation Schedule
3. Municipal Adoption
4. Planning Review Documentation
5. Public Comment Documentation
6. Comments and Responses
7. Implementation Schedule

Part 3 – General Plan Content – Turbotville Borough Act 537 Plan Update Special Study

INSTRUCTIONS FOR COMPLETING ACT 537 PLAN CONTENT AND ENVIRONMENTAL ASSESSMENT CHECKLIST

Remove and recycle these instructions prior to submission.

CHECKLIST INSTRUCTIONS

These instructions are designed to assist the applicant in completing the *Act 537 Plan Content and Environmental Assessment Checklist*.

This checklist is composed of three parts: one for “General Information,” one for “Administrative Completeness,” and one for “General Plan Content”. A plan must be **administratively complete** in order to be formally reviewed by the Department of Environmental Protection (DEP). The “General Plan Content” portion of the checklist identifies each of the issues that must be addressed in your Act 537 Plan Update based on the pre-planning meeting between you and/or your consultant and DEP.

Use the right-hand column blanks in the checklist to identify the page in the plan on which each planning issue is found or to reference a previously approved update or special study (title and page number).

If you determine a planning issue is not applicable even though it was previously thought to be needed, please explain your decision within the text of the plan (or as a footnote) and indicate the page number where this documentation is found.

When information required as part of an official plan update revision has been developed separately or in a previous update revision, incorporate the information by reference to the planning document and page.

For specific details covering the Act 537 planning requirements, refer to 25 *Pa. Code* Chapters 71 and 73 of DEP’s regulations.

Wastewater projects proposing funding through the following sources must prepare an “Environmental Report” as described in the Uniform Environmental Review (UER) process and include it with the plan submission designated as “Plan-Appendix A”. The following funding programs use the UER process.

- The Clean Water State Revolving Loan Fund (PENNVEST, DEP, EPA)
- The RUS Water and Waste Disposal Grant and Loan Program (USDA-RD)
- The Community Development Block Grant Program (DCED, HUG)
- Other Federal Funding Efforts (EPA)

The checklist items or portions of checklist items required in the Act 537 Plan Update revision and that are also included in the UER process are indicated by **shading**. Most of the “Environmental Report” document may be constructed from the Act 537 Official Plan Update revision by using “copy & paste” techniques. The technical guidance document *Guidelines for the Uniform Environmental Review Process in Pennsylvania* (381-5511-111) is available electronically in DEP’s eLibrary online at www.dep.pa.gov.

After Municipal Adoption by Resolution, submit 3 copies of the plan, any attachments or addenda and this checklist to DEP.

A copy of this completed checklist must be included with your Act 537 plan. DEP will use the “DEP USE ONLY” column during the completeness evaluation of the plan. This column may also be used by DEP during the pre-planning meeting with the municipality to identify planning elements that are not required to be included in the plan.



ACT 537 PLAN CONTENT AND ENVIRONMENTAL ASSESSMENT CHECKLIST

PART 1 GENERAL INFORMATION

A. Project Information

1. Project Name Turbotville Act 537 Update Special Study
2. Brief Project Description Special study to evaluate the pending asset acquisition of the Turbotville Borough wastewater system by Pennsylvania-American Water Company.

B. Client (Municipality) Information

Municipality Name	County	City	Boro	Twp
Turbotville	Northumberland	<input type="checkbox"/>	<input checked="" type="checkbox"/>	<input type="checkbox"/>
Municipality Contact Individual - Last Name	First Name	MI	Suffix	Title
Betz	F. Patrick			Council President
Additional Individual Last Name	First Name	MI	Suffix	Title
Miller	Diane			Secretary
Municipality Mailing Address Line 1	Mailing Address Line 2			
P.O. Box 264				
Address Last Line -- City	State	ZIP+4		
Turbotville	PA	17772		
Phone + Ext.	FAX (optional)	Email (optional)		
570-649-5476				

C. Site Information

Site (or Project) Name	(Municipal Name) Act 537 Plan
Turbotville Wastewater System	
Site Location Line 1	Site Location Line 2
2 Adam Street	

D. Project Consultant Information

Last Name	First Name	MI	Suffix
Hulstein	Ewoud		
Title	Consulting Firm Name		
Engineering Project Manager	Pennsylvania-American Water Company		
Mailing Address Line 1	Mailing Address Line 2		
852 Wesley Drive			
Address Last Line -- City	State	ZIP+4	Country
Mechanicsburg	PA	17055	USA
Email	Phone + Ext.	FAX	
ewoud.hulstein@amwater.com	717-550-1513		

PART 2 ADMINISTRATIVE COMPLETENESS CHECKLIST

DEP Use Only	Indicate Page #(s) in Plan	In addition to the main body of the plan, the plan must include items one through eight listed below to be accepted for formal review by DEP. Incomplete plans may be denied unless the municipality is clearly requesting an advisory review.
_____	<u>TOC</u>	<ol style="list-style-type: none"> 1. Table of Contents 2. Plan Summary
_____	<u>Part 2</u>	A. Identify the proposed service areas and major problems evaluated in the plan. (Reference - 25 Pa. Code §71.21(a)(7)(i)).
_____	<u>Part 2</u>	B. Identify the alternative(s) chosen to solve the problems and serve the areas of need identified in the plan. Also, include any institutional arrangements necessary to implement the chosen alternative(s). (Reference - 25 Pa. Code §71.21(a)(7)(ii)).
_____	<u>Part 2</u>	C. Present the estimated cost of implementing the proposed alternative (including the user fees) and the proposed funding method to be used. (Reference - 25 Pa. Code §71.21(a)(7)(ii)).
_____	<u>Part 2</u>	D. Identify the municipal commitments necessary to implement the Plan. (Reference - 25 Pa. Code §71.21(a)(7)(iii)).
_____	<u>Part 2</u>	E. Provide a schedule of implementation for the project that identifies the major milestones with dates necessary to accomplish the project to the point of operational status. (Reference - 25 Pa. Code §71.21(a)(7)(iv)).
_____	<u>Part 2</u>	3. Municipal Adoption: <i>Original</i> , signed and sealed Resolution of Adoption by the municipality which contains, at a minimum, alternatives chosen and a commitment to implement the Plan in accordance with the implementation schedule. (Reference - 25 Pa. Code §71.31(f)) Section V.F. of the Planning Guide.
_____	<u>Part 2</u>	4. Planning Commission / County Health Department Comments: Evidence that the municipality has requested, reviewed and considered comments by appropriate official planning agencies of the municipality, planning agencies of the county, planning agencies with area wide jurisdiction (where applicable), and any existing county or joint county departments of health. (Reference - 25 Pa. Code §71.31(b)) Section V.E.1 of the Planning Guide.
_____	<u>Part 2</u>	5. Publication: Proof of Public Notice which documents the proposed plan adoption, plan summary, and the establishment and conduct of a 30-day comment period. (Reference - 25 Pa. Code §71.31(c)) Section V.E.2 of the Planning Guide.
_____	<u>Part 2</u>	6. Comments and Responses: Copies of all written comments received and municipal response to each comment in relation to the proposed plan. (Reference - 25 Pa. Code §71.31(c)) Section V.E.2 of the Planning Guide.
_____	<u>Part 2</u>	7. Implementation Schedule: A complete project implementation schedule with milestone dates specific for each existing and future area of need. Other activities in the project implementation schedule should be indicated as occurring a finite number of days from a major milestone. (Reference - 25 Pa. Code §71.31(d)) Section V.F. of the Planning Guide. Include dates for the future initiation of feasibility evaluations in the project's implementation schedule for areas proposing completion of sewage facilities for planning periods in excess of five years. (Reference - 25 Pa. Code §71.21(c)).
_____	<u>NA</u>	8. Consistency Documentation: Documentation indicating that the appropriate agencies have received, reviewed and concurred with the method proposed to resolve identified inconsistencies within the proposed alternative and consistency requirements in 25 Pa. Code §71.21.(a)(5)(i-iii). (Reference - 25 Pa. Code §71.31(e)). Appendix B of the Planning Guide.

PART 3 GENERAL PLAN CONTENT CHECKLIST

DEP Use Only	Indicate Page #(s) in Plan	Item Required
_____	<u>Part 3</u>	I. Previous Wastewater Planning
_____		A. Identify, describe and briefly analyze all past wastewater planning for its impact on the current planning effort:
_____	<u>Part 3</u>	1. Previously undertaken under the Pennsylvania Sewage Facilities Act (Act). (Reference - Act 537, 35 P.S. §750.5(d)(1)).
_____	<u>Part 3</u>	2. Has not been carried out according to an approved implementation schedule contained in the plans. (Reference - 25 Pa. Code §71.21(a)(5)(i)(A-D)). Section V.F of the Planning Guide.
_____	<u>Part 3</u>	3. Is anticipated or planned by applicable sewer authorities or approved under a Chapter 94 Corrective Action Plan. (Reference - 25 Pa. Code §71.21(a)(5)(i)(A&B)). Section V.D. of the Planning Guide.
_____	<u>Part 3</u>	4. Through planning modules for new land development, planning “exemptions” and addenda. (Reference - 25 Pa. Code §71.21(a)(5)(i)(A)).
_____	<u>Part 3</u>	II. Physical and Demographic Analysis utilizing written description and mapping (All items listed below require maps, and all maps should show all current lots and structures and be of appropriate scale to clearly show significant information).
_____	<u>Part 3</u>	A. Identification of planning area(s), municipal boundaries, Sewer Authority/Management Agency service area boundaries. (Reference – 25 Pa. Code §71.21(a)(1)(i)).
_____	<u>Part 3</u>	B. Identification of physical characteristics (streams, lakes, impoundments, natural conveyance, channels, drainage basins in the planning area). (Reference - 25 Pa. Code §71.21(a)(1)(ii)).
_____	<u>NA</u>	C. Soils - Analysis with description by soil type and soils mapping for areas not presently served by sanitary sewer service. Show areas suitable for in-ground onlot systems, elevated sand mounds, individual residential spray irrigation systems (IRSIS), and areas unsuitable for soil dependent systems. (Reference - 25 Pa. Code §71.21(a)(1)(iii)). Show Prime Agricultural Soils and any locally protected agricultural soils. (Reference - 25 Pa. Code §71.21(a)(1)(iii)).
_____	<u>NA</u>	D. Geologic Features - (1) Identification through analysis, (2) mapping and (3) their relation to existing or potential nitrate-nitrogen pollution and drinking water sources. Include areas where existing nitrate-nitrogen levels are in excess of 5 mg/L. (Reference - 25 Pa. Code §71.21(a)(1)(iii)).
_____	<u>NA</u>	E. Topography - Depict areas with slopes that are suitable for conventional systems; slopes that are suitable for elevated sand mounds and slopes that are unsuitable for onlot systems. (Reference - 25 Pa. Code §71.21(a)(1)(ii)).
_____	<u>NA</u>	F. Potable Water Supplies - Identification through mapping, description and analysis. Include public water supply service areas and available public water supply capacity and aquifer yield for groundwater supplies. (Reference - 25 Pa. Code §71.21(a)(1)(vi)). Section V.C. of the Planning Guide.
_____	<u>NA</u>	G. Wetlands-Identify wetlands as defined in 25 Pa. Code Chapter 105 by description, analysis and mapping. Include National Wetland Inventory mapping and potential wetland areas per the United States Department of Agricultural (USDA) Natural Resources Conservation Service (NRCS) mapped hydric soils. Proposed collection, conveyance and treatment facilities and lines must be located and labeled, along with the identified wetlands, on the map. (Reference - 25 Pa. Code §71.21(a)(1)(v)). Appendix B, Section II.I of the Planning Guide.

- _____ Part 3 III. **Existing Sewage Facilities in the Planning Area - Identifying the Existing Needs**
- A. Identify, map and describe municipal and non-municipal, individual and community sewerage systems in the planning area including:
- _____ Part 3 1. Location, size and ownership of treatment facilities, main intercepting lines, pumping stations and force mains including their size, capacity, point of discharge. Also include the name of the receiving stream, drainage basin, and the facility's effluent discharge requirements. (Reference - 25 Pa. Code §71.21(a)(2)(i)(A)).
- _____ Part 3 2. A narrative and schematic diagram of the facility's basic treatment processes including the facility's National Pollutant Discharge Elimination System (NPDES) permitted capacity, and the Clean Streams Law permit number. (Reference - 25 Pa. Code §71.21(a)(2)(i)(A)).
- _____ Part 3 3. A description of problems with existing facilities (collection, conveyance and/or treatment), including existing or projected overload under 25 Pa. Code Chapter 94 (relating to municipal wasteload management) or violations of the NPDES permit, Clean Streams Law permit, or other permit, rule or regulation of DEP. (Reference - 25 Pa. Code §71.21(a)(2)(i)(B)).
- _____ Part 3 4. Details of scheduled or in-progress upgrading or expansion of treatment facilities and the anticipated completion date of the improvements. Discuss any remaining reserve capacity and the policy concerning the allocation of reserve capacity. Also discuss the compatibility of the rate of growth to existing and proposed wastewater treatment facilities. (Reference - 25 Pa. Code §71.21(a)(4)(i & ii)).
- _____ NA 5. A detailed description of the municipality's operation and maintenance (O & M) requirements for small flow treatment facility systems, including the status of past and present compliance with these requirements and any other requirements relating to sewage management programs (SMPs). (Reference - 25 Pa. Code §71.21(a)(2)(i)(C)).
- _____ Part 3 6. Disposal areas, if other than stream discharge, and any applicable groundwater limitations. (Reference - 25 Pa. Code §71.21(a)(4)(i & ii)).
- _____ NA B. Using DEP's publication titled *Act 537 Sewage Disposal Needs Identification* (3800-BK-DEP1949), identify, map and describe areas that utilize individual and community onlot sewage disposal and, unpermitted collection and disposal systems ("wildcat" sewers, borehole disposal, etc.) and retaining tank systems in the planning area including:
- _____ NA 1. The types of onlot systems in use. (Reference - 25 Pa. Code §71.21(a)(2)(ii)(A)).
- _____ NA 2. A sanitary survey complete with description, map and tabulation of documented and potential public health, pollution, and operational problems (including malfunctioning systems) with the systems, including violations of local ordinances, the Act, the Clean Stream Law or regulations promulgated thereunder. (Reference - 25 Pa. Code §71.21(a)(2)(ii)(B)).
- _____ NA 3. A comparison of the types of onlot sewage systems installed in an area with the types of systems which are appropriate for the area according to soil, geologic conditions, topographic limitations sewage flows, and 25 Pa. Code Chapter 73 (relating to standards for sewage disposal facilities). (Reference - 25 Pa. Code §71.21(a)(2)(ii)(C)).
- _____ NA 4. An individual water supply survey to identify possible contamination by malfunctioning onlot sewage disposal systems consistent with DEP's *Act 537 Sewage Disposal Needs Identification* publication. (Reference - 25 Pa. Code §71.21(a)(2)(ii)(B)).

- _____ NA 5. Detailed description of O & M requirements of the municipality for individual and small volume community onlot systems, including the status of past and present compliance with these requirements and any other requirements relating to SMPs. (Reference - 25 Pa. Code §71.21(a)(2)(i)(C)).
- _____ NA C. Identify wastewater sludge and septage generation, transport and disposal methods. Include this information in the sewage facilities alternative analysis including:
 - _____ NA 1. Location of sources of wastewater sludge or septage (Septic tanks, holding tanks, wastewater treatment facilities). (Reference – 25 Pa. Code §71.71).
 - _____ NA 2. Quantities of the types of sludges or septage generated. (Reference - 25 Pa. Code §71.71).
 - _____ NA 3. Present disposal methods, locations, capacities and transportation methods. (Reference - 25 Pa. Code §71.71).

_____ Part 3 **IV. Future Growth and Land Development**

- _____ NA A. Identify and briefly summarize all municipal and county planning documents adopted pursuant to the Pennsylvania Municipalities Planning Code (Act 247) including:
 - _____ NA 1. All land use plans and zoning maps that identify residential, commercial, industrial, agricultural, recreational and open space areas. (Reference - 25 Pa. Code §71.21(a)(3)(iv)).
 - _____ NA 2. Zoning or subdivision regulations that establish lot sizes predicated on sewage disposal methods. (Reference – 25 Pa. Code §71.21(a)(3)(iv)).
 - _____ NA 3. All limitations and plans related to floodplain and stormwater management and special protection (25 Pa. Code Chapter 93) areas. (Reference - 25 Pa. Code §71.21(a)(3)(iv)) Appendix B, Section II.F of the Planning Guide.
- _____ NA B. Delineate and describe the following through map, text and analysis.
 - _____ NA 1. Areas with existing development or plotted subdivisions. Include the name, location, description, total number of equivalent dwelling units (EDUs) in development, total number of EDUs currently developed and total number of EDUs remaining to be developed (include time schedule for EDUs remaining to be developed). (Reference - 25 Pa. Code §71.21(a)(3)(i)).
 - _____ NA 2. Land use designations established under the Pennsylvania Municipalities Planning Code (35 P.S. 10101-11202), including residential, commercial and industrial areas. (Reference - 25 Pa. Code §71.21(a)(3)(ii)). Include a comparison of proposed land use as allowed by zoning and existing sewage facility planning. (Reference - 25 Pa. Code §71.21(a)(3)(iv)).
 - _____ NA 3. Future growth areas with population and EDU projections for these areas using historical, current and future population figures and projections of the municipality. Discuss and evaluate discrepancies between local, county, state and federal projections as they relate to sewage facilities. (Reference - 25 Pa. Code §71.21(a)(1)(iv) and (a)(3)(iii)).
 - _____ NA 4. Zoning, and/or subdivision regulations; local, county or regional comprehensive plans; and existing plans of any other agency relating to the development, use and protection of land and water resources with special attention to: (Reference - 25 Pa. Code §71.21(a)(3)(iv)).
 - public ground/surface water supplies
 - recreational water use areas
 - groundwater recharge areas
 - industrial water use
 - wetlands

_____ NA 5. Sewage planning necessary to provide adequate wastewater treatment for 5 and 10-year future planning periods based on projected growth of existing and proposed wastewater collection and treatment facilities. (Reference - 25 Pa. Code §71.21(a)(3)(v)).

_____ Part 3 **V. Identify Alternatives to Provide New or Improved Wastewater Disposal Facilities**

A. Conventional collection, conveyance, treatment and discharge alternatives including:

_____ NA 1. The potential for regional wastewater treatment. (Reference - 25 Pa. Code §71.21(a)(4)).

_____ NA 2. The potential for extension of existing municipal or non-municipal sewage facilities to areas in need of new or improved sewage facilities. (Reference - 25 Pa. Code §71.21(a)(4)(i)).

_____ NA 3. The potential for the continued use of existing municipal or non-municipal sewage facilities through one or more of the following: (Reference - 25 Pa. Code §71.21(a)(4)(ii)).

_____ NA a. Repair. (Reference - 25 Pa. Code §71.21(a)(4)(ii)(A)).

_____ NA b. Upgrading. (Reference - 25 Pa. Code §71.21(a)(4)(ii)(B)).

_____ NA c. Reduction of hydraulic or organic loading to existing facilities. (Reference - 25 Pa. Code §71.71).

_____ NA d. Improved O & M. (Reference - 25 Pa. Code §71.21(a)(4)(ii)(C)).

_____ NA e. Other applicable actions that will resolve or abate the identified problems. (Reference - 25 Pa. Code §71.21(a)(4)(ii)(D)).

_____ NA 4. Repair or replacement of existing collection and conveyance system components. (Reference - 25 Pa. Code §71.21(a)(4)(ii)(A)).

_____ NA 5. The need for construction of new community sewage systems including sewer systems and/or treatment facilities. (Reference - 25 Pa. Code §71.21(a)(4)(iii)).

_____ NA 6. Use of innovative/alternative methods of collection/conveyance to serve needs areas using existing wastewater treatment facilities. (Reference - 25 Pa. Code §71.21(a)(4)(ii)(B)).

_____ NA B. The use of individual sewage disposal systems including IRSIS systems based on:

_____ NA 1. Soil and slope suitability. (Reference - 25 Pa. Code §71.21(a)(2)(ii)(C)).

_____ NA 2. Preliminary hydrogeologic evaluation. (Reference - 25 Pa. Code §71.21(a)(2)(ii)(C)).

_____ NA 3. The establishment of a SMP. (Reference - 25 Pa. Code §71.21(a)(4)(iv)). See also Part "F" below.

_____ NA 4. The repair, replacement or upgrading of existing malfunctioning systems in areas suitable for onlot disposal considering: (Reference - 25 Pa. Code §71.21(a)(4)).

_____ NA a. Existing technology and sizing requirements of 25 Pa. Code Chapter 73. (Reference - 25 Pa. Code §73.31-§73.72).

_____ NA b. Use of expanded absorption areas or alternating absorption areas. (Reference - 25 Pa. Code §73.16).

_____ NA c. Use of water conservation devices. (Reference - 25 Pa. Code §71.73(b)(2)(iii)).

- _____ NA C. The use of small flow sewage treatment facilities or package treatment facilities to serve individual homes or clusters of homes with consideration of: (Reference - 25 Pa. Code §71.64(d)).
- _____ NA 1. Treatment and discharge requirements. (Reference - 25 Pa. Code §71.64(d)).
- _____ NA 2. Soil suitability. (Reference - 25 Pa. Code §71.64(c)(1)).
- _____ NA 3. Preliminary hydrogeologic evaluation. (Reference - 25 Pa. Code §71.64(c)(2)).
- _____ NA 4. Municipal, Local Agency or other controls over O & M requirements through a SMP. (Reference - 25 Pa. Code §71.64(d)). See Part "F" below.
- _____ NA D. The use of community land disposal alternatives including:
- _____ NA 1. Soil and site suitability. (Reference - 25 Pa. Code §71.21(a)(2)(ii)(C)).
- _____ NA 2. Preliminary hydrogeologic evaluation. (Reference - 25 Pa. Code §71.21(a)(2)(ii)(C)).
- _____ NA 3. Municipality, Local Agency or other controls over O & M requirements through a SMP. (Reference - 25 Pa. Code §71.21(a)(2)(ii)(C)). See Part "F" below.
- _____ NA 4. The rehabilitation or replacement of existing malfunctioning community land disposal systems. (See Part "V", B, 4, a, b, c above). See also Part "F" below.
- _____ NA E. The use of retaining tank alternatives on a temporary or permanent basis including: (Reference - 25 Pa. Code §71.21(a)(4)).
- _____ NA 1. Commercial, residential and industrial use. (Reference - 25 Pa. Code §71.63(e)).
- _____ NA 2. Designated conveyance facilities (pumper trucks). (Reference - 25 Pa. Code §71.63(b)(2)).
- _____ NA 3. Designated treatment facilities or disposal site. (Reference - 25 Pa. Code §71.63(b)(2)).
- _____ NA 4. Implementation of a retaining tank ordinance by the municipality. (Reference - 25 Pa. Code §71.63(c)(3)). See Part "F" below.
- _____ NA 5. Financial guarantees when retaining tanks are used as an interim sewage disposal measure. (Reference - 25 Pa. Code §71.63(c)(2)).
- _____ NA F. SMPs to assure the future O & M of existing and proposed sewage facilities through:
- _____ NA 1. Municipal ownership or control over the O & M of individual onlot sewage disposal systems, small flow treatment facilities, or other traditionally non-municipal treatment facilities. (Reference - 25 Pa. Code §71.21(a)(4)(iv)).
- _____ NA 2. Required inspection of sewage disposal systems on a schedule established by the municipality. (Reference - 25 Pa. Code §71.73(b)(1)).
- _____ NA 3. Required maintenance of sewage disposal systems including septic and aerobic treatment tanks and other system components on a schedule established by the municipality. (Reference - 25 Pa. Code §71.73(b)(2)).
- _____ NA 4. Repair, replacement or upgrading of malfunctioning onlot sewage systems. (Reference - 25 Pa. Code §71.21(a)(4)(iv) and §71.73(b)(5)) through:
- _____ NA a. Aggressive pro-active enforcement of ordinances that require O & M and prohibit malfunctioning systems. (Reference - 25 Pa. Code §71.73(b)(5)).
- _____ NA b. Public education programs to encourage proper O & M and repair of sewage disposal systems.
- _____ NA 5. Establishment of joint municipal SMPs. (Reference - 25 Pa. Code

- _____ §71.73(b)(8)).
- _____ NA 6. Requirements for bonding, escrow accounts, management agencies or associations to assure O & M for non-municipal facilities. (Reference - 25 Pa. Code §71.71).
- _____ NA G. Non-structural comprehensive planning alternatives that can be undertaken to assist in meeting existing and future sewage disposal needs including: (Reference - 25 Pa. Code §71.21(a)(4)).
- _____ NA 1. Modification of existing comprehensive plans involving:
- _____ NA a. Land use designations. (Reference - 25 Pa. Code §71.21(a)(4)).
- _____ NA b. Densities. (Reference - 25 Pa. Code §71.21(a)(4)).
- _____ NA c. Municipal ordinances and regulations. (Reference - 25 Pa. Code §71.21(a)(4)).
- _____ NA d. Improved enforcement. (Reference - 25 Pa. Code §71.21(a)(4)).
- _____ NA e. Protection of drinking water sources. (Reference - 25 Pa. Code §71.21(a)(4)).
- _____ NA 2. Consideration of a local comprehensive plan to assist in producing sound economic and consistent land development. (Reference - 25 Pa. Code §71.21(a)(4)).
- _____ NA 3. Alternatives for creating or changing municipal subdivision regulations to assure long-term use of on-site sewage disposal that consider lot sizes and protection of replacement areas. (Reference - 25 Pa. Code §71.21(a)(4)).
- _____ NA 4. Evaluation of existing local agency programs and the need for technical or administrative training. (Reference - 25 Pa. Code §71.21(a)(4)).
- _____ NA H. A no-action alternative which includes discussion of both short-term and long-term impacts on: (Reference - 25 Pa. Code §71.21(a)(4)).
- _____ NA 1. Water quality/public health. (Reference - 25 Pa. Code §71.21(a)(4)).
- _____ NA 2. Growth potential (residential, commercial, industrial). (Reference - 25 Pa. Code §71.21(a)(4)).
- _____ NA 3. Community economic conditions. (Reference - 25 Pa. Code §71.21(a)(4)).
- _____ NA 4. Recreational opportunities. (Reference - 25 Pa. Code §71.21(a)(4)).
- _____ NA 5. Drinking water sources. (Reference - 25 Pa. Code §71.21(a)(4)).
- _____ NA 6. Other environmental concerns. (Reference - 25 Pa. Code §71.21(a)(4)).

_____ Part 3 **VI. Evaluation of Alternatives**

A. Technically feasible alternatives identified in Section V of this checklist must be evaluated for consistency with respect to the following: (Reference - 25 Pa. Code §71.21(a)(5)(i)).

_____ Part 3 1. Applicable plans developed and approved under **Sections 4 and 5 of the Clean Streams Law or Section 208 of the Clean Water Act** (33 U.S.C.A. 1288). (Reference - 25 Pa. Code §71.21(a)(5)(i)(A)). Appendix B, Section II.A of the Planning Guide.

_____ Part 3 2. Municipal wasteload management **Corrective Action Plans or Annual Reports** developed under 25 Pa. Code Chapter 94. (Reference - 25 Pa. Code §71.21(a)(5)(i)(B)). The municipality's recent Wasteload Management (25 Pa. Code Chapter 94) Reports should be examined to determine if the proposed alternative is consistent with the recommendations and findings of the report. Appendix B, Section II.B of the Planning Guide.

_____ Part 3 3. Plans developed under **Title II of the Clean Water Act** (33 U.S.C.A.

1281-1299) or **Titles II and VI of the Water Quality Act of 1987** (33 U.S.C.A 1251-1376). (Reference - 25 Pa. Code §71.21(a)(5)(i)(C)). Appendix B, Section II.E of the Planning Guide.

- | | | |
|-------|---------------|---|
| _____ | <u>Part 3</u> | 4. Comprehensive plans developed under the Pennsylvania Municipalities Planning Code. (Reference - 25 Pa. Code §71.21(a)(5)(i)(D)). The municipality's comprehensive plan must be examined to assure that the proposed wastewater disposal alternative is consistent with land use and all other requirements stated in the comprehensive plan. Appendix B, Section II.D of the Planning Guide. |
| _____ | <u>Part 3</u> | 5. Antidegradation requirements as contained in 25 Pa. Code Chapters 93, 95 and 102 (relating to water quality standards, wastewater treatment requirements and erosion control) and the Clean Water Act. (Reference - 25 Pa. Code §71.21(a)(5)(i)(E)). Appendix B, Section II.F of the Planning Guide. |
| _____ | <u>Part 3</u> | 6. State Water Plans developed under the Water Resources Planning Act (42 U.S.C.A. 1962-1962 d-18). (Reference - 25 Pa. Code §71.21(a)(5)(i)(F)). Appendix B, Section II.C of the Planning Guide. |
| _____ | <u>Part 3</u> | 7. Pennsylvania Prime Agricultural Land Policy contained in Title 4 of the Pennsylvania Code, Chapter 7, Subchapter W. Provide narrative on local municipal policy and an overlay map on prime agricultural soils. (Reference - 25 Pa. Code §71.21(a)(5)(i)(G)). Appendix B, Section II.G of the Planning Guide. |
| _____ | <u>Part 3</u> | 8. County Stormwater Management Plans approved by DEP under the Storm Water Management Act (32 P.S. 680.1-680.17). (Reference - 25 Pa. Code §71.21(a)(5)(i)(H)). Conflicts created by the implementation of the proposed wastewater alternative and the existing recommendations for the management of stormwater in the county Stormwater Management Plan must be evaluated and mitigated. If no plan exists, no conflict exists. Appendix B, Section II.H of the Planning Guide. |
| _____ | <u>Part 3</u> | 9. Wetland Protection. Using wetland mapping developed under Checklist Section II.G, identify and discuss mitigative measures including the need to obtain permits for any encroachments on wetlands from the construction or operation of any proposed wastewater facilities. (Reference - 25 Pa. Code §71.21(a)(5)(i)(I)) Appendix B, Section II.I of the Planning Guide. |
| _____ | <u>Part 3</u> | 10. Protection of rare, endangered or threatened plant and animal species as identified by the Pennsylvania Natural Diversity Inventory (PNDI). (Reference - 25 Pa. Code §71.21(a)(5)(i)(J)). Provide DEP with a copy of the completed <i>PNDI Manual Project Submission Form</i> . Also provide a copy of the response letters from the 4 jurisdictional agencies regarding the findings of the PNDI search. Appendix B, Section II.J of the Planning Guide. |
| _____ | <u>Part 3</u> | 11. Historical and archaeological resource protection under P.C.S. Title 37, Section 507 relating to cooperation by public officials with the Pennsylvania Historical and Museum Commission (PHMC). (Reference - 25 Pa. Code §71.21(a)(5)(i)(K)). Provide DEP with a completed copy of a <i>Cultural Resource Notice</i> and a return receipt for its submission to PHMC. Provide a copy of the response letter or review stamp from the Bureau of Historic Preservation (BHP) indicating the project will have no effect on, or that there may be potential impacts on, known archaeological and historical sites and any avoidance and mitigation measures required. Appendix B, Section II.K of the Planning Guide. |

- _____ Part 3 B. Provide for the resolution of any inconsistencies in any of the points identified in Section VI.A. of this checklist by submitting a letter from the appropriate agency stating that the agency has received, reviewed and concurred with the resolution of identified inconsistencies. (Reference - 25 Pa. Code §71.21(a)(5)(ii). Appendix B of the Planning Guide.
- _____ Part 3 C. Evaluate alternatives identified in Section V of this checklist with respect to applicable water quality standards, effluent limitations or other technical, legislative or legal requirements. (Reference - 25 Pa. Code §71.21(a)(5)(iii)).
- _____ Part 3 D. Provide cost estimates using present worth analysis for construction, financing, ongoing administration, O & M and user fees for alternatives identified in Section V of this checklist. Estimates shall be limited to areas identified in the plan as needing improved sewage facilities within 5 years from the date of plan submission. (Reference - 25 Pa. Code §71.21(a)(5)(iv)).
- _____ Part 3 E. Provide an analysis of the funding methods available to finance the proposed alternatives evaluated in Section V of this checklist. Also provide documentation to demonstrate which alternative and financing scheme combination is the most cost-effective; and a contingency financial plan to be used if the preferred method of financing cannot be implemented. The funding analysis shall be limited to areas identified in the plan as needing improved sewage facilities within 5 years from the date of the plan submission. (Reference - 25 Pa. Code §71.21(a)(5)(v)).
- _____ Part 3 F. Analyze the need for immediate or phased implementation of each alternative proposed in Section V of this checklist including: (Reference - 25 Pa. Code §71.21(a)(5)(vi)).
 - _____ NA 1. A description of any activities necessary to abate critical public health hazards pending completion of sewage facilities or implementation of SMPs. (Reference - 25 Pa. Code §71.21(a)(5)(vi)(A)).
 - _____ NA 2. A description of the advantages, if any, in phasing construction of the facilities or implementation of a SMP justifying time schedules for each phase. (Reference - 25 Pa. Code §71.21(a)(5)(vi)(B)).
- _____ Part 3 G. Evaluate administrative organizations and legal authority necessary for plan implementation. (Reference - 25 Pa. Code §71.21(a)(5)(vi)(D)).
- _____ Part 3 **VII. Institutional Evaluation**
 - _____ NA A. Provide an analysis of all existing wastewater treatment authorities, their past actions and present performance including:
 - _____ NA 1. Financial and debt status. (Reference - 25 Pa. Code §71.61(d)(2)).
 - _____ NA 2. Available staff and administrative resources. (Reference - 25 Pa. Code §71.61(d)(2)).
 - _____ NA 3. Existing legal authority to:
 - _____ NA a. Implement wastewater planning recommendations. (Reference - 25 Pa. Code §71.61(d)(2)).
 - _____ NA b. Implement system-wide O & M activities. (Reference - 25 Pa. Code §71.61(d)(2)).
 - _____ NA c. Set user fees and take purchasing actions. (Reference - 25 Pa. Code §71.61(d)(2)).
 - _____ NA d. Take enforcement actions against ordinance violators. (Reference - 25 Pa. Code §71.61(d)(2)).
 - _____ NA e. Negotiate agreements with other parties. (Reference - 25 Pa. Code §71.61(d)(2)).

- _____ NA f. Raise capital for construction and O & M of facilities. (Reference - 25 Pa. Code §71.61(d)(2)).
- _____ Part 3 B. Provide an analysis and description of the various institutional alternatives necessary to implement the proposed technical alternatives including:
- _____ Part 3 1. Need for new municipal departments or municipal authorities. (Reference - 25 Pa. Code §71.61(d)(2)).
- _____ Part 3 2. Functions of existing and proposed organizations (sewer authorities, onlot maintenance agencies, etc.). (Reference - 25 Pa. Code §71.61(d)(2)).
- _____ Part 3 3. Cost of administration, implementability, and the capability of the authority/agency to react to future needs. (Reference - 25 Pa. Code §71.61(d)(2)).
- _____ Part 3 C. Describe all necessary administrative and legal activities to be completed and adopted to ensure the implementation of the recommended alternative including:
- _____ Part 3 1. Incorporation of authorities or agencies. (Reference - 25 Pa. Code §71.61(d)(2)).
- _____ Part 3 2. Development of all required ordinances, regulations, standards and inter-municipal agreements. (Reference - 25 Pa. Code §71.61(d)(2)).
- _____ Part 3 3. Description of activities to provide rights-of-way, easements and land transfers. (Reference - 25 Pa. Code §71.61(d)(2)).
- _____ Part 3 4. Adoption of other municipal sewage facilities plans. (Reference - 25 Pa. Code §71.61(d)(2)).
- _____ Part 3 5. Any other legal documents. (Reference - 25 Pa. Code §71.61(d)(2)).
- _____ Part 3 6. Dates or timeframes for items 1-5 above on the project's implementation schedule.
- _____ Part 3 D. Identify the proposed institutional alternative for implementing the chosen technical wastewater disposal alternative. Provide justification for choosing the specific institutional alternative considering administrative issues, organizational needs and enabling legal authority. (Reference - 25 Pa. Code §71.61(d)(2)).

- _____ Part 3 **VIII. Implementation Schedule and Justification for Selected Technical & Institutional Alternatives**
- _____ Part 3 A. Identify the technical wastewater disposal alternative which best meets the wastewater treatment needs of each study area of the municipality. Justify the choice by providing documentation which shows that it is the best alternative based on:
- _____ Part 3 1. Existing wastewater disposal needs. (Reference - 25 Pa. Code §71.21(a)(6)).
- _____ Part 3 2. Future wastewater disposal needs. (5 and 10 year growth areas). (Reference - 25 Pa. Code §71.21(a)(6)).
- _____ Part 3 3. O & M considerations. (Reference - 25 Pa. Code §71.21(a)(6)).
- _____ NA 4. Cost-effectiveness. (Reference - 25 Pa. Code §71.21(a)(6)).
- _____ Part 3 5. Available management and administrative systems. (Reference - 25 Pa. Code §71.21(a)(6)).
- _____ NA 6. Available financing methods. (Reference - 25 Pa. Code §71.21(a)(6)).
- _____ Part 3 7. Environmental soundness and compliance with natural resource planning and preservation programs. (Reference - 25 Pa. Code §71.21(a)(6)).

- _____ NA B. Designate and describe the capital financing plan chosen to implement the selected alternative(s). Designate and describe the chosen back-up financing plan. (Reference - 25 Pa. Code §71.21(a)(6))
- _____ Part 3 C. Designate and describe the implementation schedule for the recommended alternative, including justification for any proposed phasing of construction or implementation of a SMP. (Reference – 25 Pa. Code §71.31(d))

- _____ NA
 - _____ NA
- IX. Environmental Report (ER) generated from the UER Process**
- A. Complete an ER as required by the UER process and as described in the DEP Technical Guidance (381-5511-111). Include this document as “Appendix A” to the Act 537 Plan Update Revision. **Note: An ER is required only for Wastewater projects proposing funding through any of the funding sources identified in the UER.**

ADDITIONAL REQUIREMENTS FOR PENNVEST PROJECTS

Municipalities that propose to implement their official sewage facilities plan updates with PENNVEST funds must meet 6 additional requirements to be eligible for such funds. See *A Guide for Preparing Act 537 Update Revisions* (362-0300-003), Appendix N for greater detail or contact the DEP regional office serving your county listed in Appendix J of the same publication.

DEP Use Only	Indicate Page #(s) in Plan	Item Required
_____	<u>NA</u>	1. Environmental Impact Assessment. (Planning Phase) The UER replaces the Environmental Impact Assessment that was a previous requirement for PENNVEST projects.
_____	<u>NA</u>	2. Cost Effectiveness (Planning Phase) The cost-effectiveness analysis should be a present-worth (or equivalent uniform annual) cost evaluation of the principle alternatives using the interest rate that is published annually by the Water Resources Council. Normally, for PENNVEST projects the applicant should select the most cost-effective alternative based upon the above analysis. Once the alternative has been selected the user fee estimates should be developed based upon interest rates and loan terms of the selected funding method.
_____		3. Second Opinion Project Review. (Design Phase)
_____		4. Minority Business Enterprise/Women’s Business Enterprise (Construction Phase)
_____		5. Civil Rights. (Construction Phase)
_____		6. Initiation of Operation/Performance Certification. (Post-construction Phase)

I/A TECHNOLOGIES

PARTIAL LISTING OF INNOVATIVE AND ALTERNATIVE TECHNOLOGIES

TREATMENT TECHNOLOGIES

Aquaculture
Aquifer Recharge
Biological Aerated Filters
Constructed Wetlands
Direct Reuse (NON-POTABLE)
Horticulture
Overland Flow
Rapid Infiltration
Silviculture
Microscreens
Controlled Release Lagoons
Swirl Concentrator

SLUDGE TREATMENT TECHNOLOGIES

Aerated Static Pile Composting
Enclosed Mechanical Composting (In vessel)
Revegetation of Disturbed Land
Aerated Windrow Composting

ENERGY RECOVERY TECHNOLOGIES

Anaerobic Digestion with more than 90 percent
Methane Recovery
Cogeneration of Electricity
Self-Sustaining Incineration

INDIVIDUAL & SYSTEM-WIDE COLLECTION TECHNOLOGIES

Cluster Systems
Septage Treatment
Small Diameter Gravity Sewers
Step Pressure Sewers
Vacuum Sewers
Variable Grade Sewers
Septic Tank Effluent Pump with
Pressure Sewers

Part 2
Section 2
Plan Summary

PLAN SUMMARY

Turbotville Borough Minor Act 537 Update Special Study

A. Proposed Service Area, Municipal Facilities Being Acquired, and Major Problems

This Act 537 Plan Update Special Study was prepared pending the acquisition of Turbotville Borough wastewater system by the Pennsylvania-American Water Company (PAWC). As documented by this Act 537 Plan Update Special Study, the contemplated acquisition of the Turbotville Borough wastewater system by PAWC, and the subsequent operation of that system by PAWC, assures operation of the system and implementation of related Act 537 Plan provisions by a technically-competent and financially-sound entity, assuring that the Act 537 Plan objectives will continue to be met.

Figure 1 depicts the Act 537 planning area which is the same as the PAWC proposed certificated franchise territory. The wastewater service territory is located entirely within Turbotville Borough (Borough). Municipal facilities being acquired by PAWC include the gravity collection system, customer service laterals from the main to the limits of the rights-of-way or easement as applicable, and the wastewater treatment plant (WWTP).

Major problems evaluated in this Special Study are related to the performance and condition of the Turbotville WWTP. The WWTP is not designed or capable of meeting current effluent requirements for total phosphorous. The WWTP is not currently nor projected to be in organic or hydraulic overload conditions; however, high daily flow rates due to collection system infiltration and inflow (I&I) have contributed to exceedances in NPDES effluents. The WWTP influent pump station is not sized to handle high daily flow rates that occur as a result of I&I. Finally, various WWTP components are in poor condition.

B. Chosen Alternative

The chosen alternative for addressing WWTP deficiencies is "Alternative C" which consists of installing a new extended aeration activated sludge WWTP. The new WWTP would consist of precast concrete basins, and would include an equalization basin, new influent pumping station, and UV disinfection system. The alternative recommended in this Special Study represents a significant investment in the Turbotville WWTP with estimated total project cost of \$3.26 Million. The chosen alternative would continue to treat the wastewater using an extended air activated sludge process. When compared to the alternative recommended in the 2017 Special Study, the alternative recommended in this Special Study shares many of the same proposed upgrades to individual WWTP components, such as replacing the influent pump station, installing UV disinfection, and installing an emergency generator.

This Special Study addresses the institutional arrangements for ownership and operation of the Turbotville Borough wastewater system. The proposed asset acquisition does not require new departments or municipal authorities. PAWC will obtain the certificated franchise territory shown in Figure 1. Turbotville Borough wastewater customers will become direct customers of PAWC. PAWC will own and operate the wastewater collection system and WWTP. As owner and operator of the wastewater system, PAWC will be responsible for the operation, maintenance, repair, replacement, and monitoring of all elements of the wastewater system. Legal actions required to implement the sale of Turbotville Borough wastewater system to PAWC are

comparable to similar asset acquisitions completed by PAWC and will include items such as change in ownership of assets and transfer of permits, right-of-ways, easements, and property.

C. Estimated Cost of Implementing Acquisition

The purchase price for Turbotville Borough wastewater assets is \$365,000. This purchase price is exclusively for the acquisition of the wastewater assets currently in place and owned and operated by Turbotville Borough. The cost of implementing the acquisition has yet to be determined, but would include all legal and associated costs with the Pennsylvania Public Utilities Commission (PUC) filing, title work, and other transaction costs necessary to close the acquisition, which will occur after the PUC has issued its Order approving the application filing (docket A-2018-3004189).

After the acquisition, the Turbotville Borough wastewater system will require capital investment to provide safe, reliable, and adequate wastewater conveyance and treatment services for Borough residents. The chosen alternative for the WWTP has an estimated total project cost of \$3.26 Million. Collection system investment is not yet known and will be determined after the entire collection system is evaluated according to the practices outlined in the latest PUC-approved Wastewater Long Term Infrastructure Improvement Plan.

If Turbotville Borough maintains ownership of its wastewater system and moves forward with the alternative from the 2017 Special Study, monthly user rates are estimated to increase from the current rate of \$40 per month to \$64.45 to \$103.93 per month, depending on PENNVEST funding or grant availability (see Table 8 in the 2017 Special Study). The chosen alternative of this Act 537 Special Study, which is the sale of Turbotville Borough's wastewater assets to PAWC and the subsequent installation of a new extended aeration activated sludge WWTP (Alternative C), would result in a typical residential wastewater customer using 3,000 gallons per month paying \$51.14 per month, and a typical residential wastewater customer using 5,000 gallons per month paying \$79.08 per month.

D. Turbotville Borough and PAWC Commitments

As the purchasing entity, PAWC commitments include all tasks and responsibilities required to own, operate, maintain, and upgrade the Turbotville Borough wastewater system. This includes compliance with applicable environmental regulations, investment in and maintenance of infrastructure, investigation of and response to any reports of sewer overflows, completion of reporting requirements such as Chapter 94 Wasteload Management Reports, review and approval of planning modules for new connections with respect to the available collection, conveyance and treatment capacity.

E. Implementation Schedule

The implementation schedule for the proposed asset acquisition is provided in Part 2, Section 7 as well as Part 3, Section VIII(B).

Part 2
Section 3
Municipal Adoption

BOROUGH OF TURBOTVILLE
NORTHUMBERLAND COUNTY, PENNSYLVANIA

RESOLUTION NO. 4-19

RESOLUTION OF THE TURBOTVILLE BOROUGH COUNCIL,
NORTHUMBERLAND COUNTY, PENNSYLVANIA (hereinafter "the municipality").

WHEREAS, Section 5 of the Act of January 24, 1966, P.L. 1535, No. 537, known as the "Pennsylvania Sewage Facilities Act," as amended, and the Rules and Regulations of the Department of Environmental Protection (Department) adopted thereunder, known as Chapter 71 of Title 25 of the Pennsylvania Code, requires the municipality to adopt an Official Sewage Facilities Plan providing for sewage services adequate to prevent contamination of waters and/or environmental health hazards with sewage wastes, and to revise said plan whenever it is necessary to meet the sewage disposal needs of the municipality, and

WHEREAS, TURBOTVILLE BOROUGH has prepared an *Act 537 Special Study dated January 2019* which serves as a supplement to the Official Sewage Facilities Plan and provides for sewage facilities in a portion of Turbotville Borough, and

The alternative of choice to be implemented is installation of a new extended aeration activated sludge wastewater treatment plant. The contemplated acquisition of the Turbotville Borough wastewater system by Pennsylvania-American Water Company (PAWC, and the subsequent operation of that system by PAWC, assures operation of the system and implementation of related Act 537 Plan provisions by a technically-competent and financially-sound entity, assuring that the Act 537 Plan objectives will continue to be met. The key implementation schedule calls for project permitting and design to be completed by 2020 and for project construction completion by 2021/2022.

WHEREAS, Turbotville Borough finds that the *Act 537 Special Study* described above, conforms to applicable zoning, subdivision, other municipal ordinances and plans and to a comprehensive program of pollution control and water quality management.

NOW, THEREFORE, BE IT RESOLVED that the Council of the Borough of Turbotville hereby adopts and submits to the Pennsylvania Department of Environmental Protection for its approval as a revision to the "Official Plan" of the municipality, the above referenced *Act 537 Special Study dated January 2019*. The municipality hereby assures the Department that said plan will be implemented as required by law. (Section 5, Pennsylvania Sewage Facilities Act as amended).

Duly adopted April 29, 2019

Attest:

Secretary

Council President

Mayor

Part 2
Section 4
Planning Review Documentation

Turbotville Borough Planning Commission
267 Broadway Street, PO Box 264 Turbotville, PA 17772
Ph. 570-649-5476 Fax 570-649-6620
turbotville5476@windstream.net

March 8, 2019

Turbotville Borough
PO Box 264
Turbotville, PA 17772

Dear Turbotville Borough Council,

This letter is to indicate that the Turbotville Planning Commission has reviewed the borough's Act 537 Study and do not have any comments.

Sincerely,

A handwritten signature in blue ink that reads "Lawrence E. Bieber". The signature is written in a cursive style with a small circle above the 'E'.

Lawrence Bieber
Chairperson
Turbotville Planning Commission

**DEPARTMENT of
ECONOMIC DEVELOPMENT & PLANNING**

COMMISSIONERS

**Richard J. Shoch, Chairman
Samuel J. Schiccatano,
Kymberley L. Best**



County of Northumberland

Administration Center
399 Stadium Drive
Sunbury, PA 17801

**Donald E. Alexander
Director of Planning &
Economic Development**

570.988.4220

don.alexander@norrycopa.net

Dear Diane Miller,

This letter is to indicate that the Northumberland County Planning & Economic Development Department has reviewed Turbotville's Act 537 Study and does not have any comments.

If you have any questions, please contact our office at 570-988-4220.

Sincerely,

Justin Skavery
Northumberland County Planning & Economic Development

**SEWAGE FACILITIES PLANNING MODULE
 COMPONENT 4A - MUNICIPAL PLANNING AGENCY REVIEW**

Note to Project Sponsor: To expedite the review of your proposal, one copy of your completed planning module package and one copy of this *Planning Agency Review Component* should be sent to the local municipal planning agency for their comments.

SECTION A. PROJECT NAME (See Section A of instructions)

Project Name

Turbotville Boro Act 537 Special Study

SECTION B. REVIEW SCHEDULE (See Section B of instructions)

1. Date plan received by municipal planning agency 3-1-2019
2. Date review completed by agency 3-8-2019

SECTION C. AGENCY REVIEW (See Section C of instructions)

- | Yes | No | |
|-------------------------------------|-------------------------------------|---|
| <input checked="" type="checkbox"/> | <input type="checkbox"/> | 1. Is there a municipal comprehensive plan adopted under the Municipalities Planning Code (53 P.S. 10101, <i>et seq.</i>)? |
| <input checked="" type="checkbox"/> | <input type="checkbox"/> | 2. Is this proposal consistent with the comprehensive plan for land use?
If no, describe the inconsistencies _____ |
| <input checked="" type="checkbox"/> | <input type="checkbox"/> | 3. Is this proposal consistent with the use, development, and protection of water resources?
If no, describe the inconsistencies _____ |
| <input checked="" type="checkbox"/> | <input type="checkbox"/> | 4. Is this proposal consistent with municipal land use planning relative to Prime Agricultural Land Preservation? |
| <input type="checkbox"/> | <input checked="" type="checkbox"/> | 5. Does this project propose encroachments, obstructions, or dams that will affect wetlands?
If yes, describe impacts _____ |
| <input type="checkbox"/> | <input checked="" type="checkbox"/> | 6. Will any known historical or archaeological resources be impacted by this project?
If yes, describe impacts _____ |
| <input type="checkbox"/> | <input checked="" type="checkbox"/> | 7. Will any known endangered or threatened species of plant or animal be impacted by this project?
If yes, describe impacts _____ |
| <input checked="" type="checkbox"/> | <input type="checkbox"/> | 8. Is there a municipal zoning ordinance? |
| <input checked="" type="checkbox"/> | <input type="checkbox"/> | 9. Is this proposal consistent with the ordinance?
If no, describe the inconsistencies _____ |
| <input type="checkbox"/> | <input checked="" type="checkbox"/> | 10. Does the proposal require a change or variance to an existing comprehensive plan or zoning ordinance? |
| <input type="checkbox"/> | <input checked="" type="checkbox"/> | 11. Have all applicable zoning approvals been obtained? |
| <input checked="" type="checkbox"/> | <input type="checkbox"/> | 12. Is there a municipal subdivision and land development ordinance? |

SECTION C. AGENCY REVIEW (continued)

Yes	No	
<input checked="" type="checkbox"/>	<input type="checkbox"/>	13. Is this proposal consistent with the ordinance? If no, describe the inconsistencies _____
<input checked="" type="checkbox"/>	<input type="checkbox"/>	14. Is this plan consistent with the municipal Official Sewage Facilities Plan? If no, describe the inconsistencies _____
<input type="checkbox"/>	<input checked="" type="checkbox"/>	15. Are there any wastewater disposal needs in the area adjacent to this proposal that should be considered by the municipality? If yes, describe _____
<input type="checkbox"/>	<input checked="" type="checkbox"/>	16. Has a waiver of the sewage facilities planning requirements been requested for the residual tract of this subdivision?
<input type="checkbox"/>	<input type="checkbox"/>	If yes, is the proposed waiver consistent with applicable ordinances? If no, describe the inconsistencies <u>Proposed plan has no residual tracts = land not included</u>
17. Name, title and signature of planning agency staff member completing this section:		
Name: <u>Lawrence Breber</u>		
Title: <u>Chairperson Planning Commission Turbotville</u>		
Signature: <u>Lawrence E. Breber</u>		
Date: <u>3-8-19</u>		
Name of Municipal Planning Agency: <u>Turbotville Planning Commission</u>		
Address: <u>PO Box 264 Turbotville, PA 17772</u>		
Telephone Number: <u>570-649-5476</u>		

SECTION D. ADDITIONAL COMMENTS (See Section D of instructions)

This component does not limit municipal planning agencies from making additional comments concerning the relevancy of the proposed plan to other plans or ordinances. If additional comments are needed, attach additional sheets.

The planning agency must complete this component within 60 days.

This component and any additional comments are to be returned to the applicant.



DEP Code #: _____

**SEWAGE FACILITIES PLANNING MODULE
COMPONENT 4B - COUNTY PLANNING AGENCY REVIEW**

(or Planning Agency with Areawide Jurisdiction)

Note to Project Sponsor: To expedite the review of your proposal, one copy of your completed planning package and one copy of this *Planning Agency Review Component* should be sent to the county planning agency or planning agency with areawide jurisdiction for their comments.

SECTION A. PROJECT NAME (See Section A of instructions)

Project Name Turbotville Borough Act 537 Plan Update Special Study (Feb 2019)

SECTION B. REVIEW SCHEDULE (See Section B of instructions)

1. Date plan received by county planning agency March 4, 2019
2. Date plan received by planning agency with areawide jurisdiction 1
Agency name Northumberland County Planning Dept.
3. Date review completed by agency March 4, 2019

SECTION C. AGENCY REVIEW (See Section C of instructions)

- | Yes | No | |
|-------------------------------------|-------------------------------------|--|
| <input checked="" type="checkbox"/> | <input type="checkbox"/> | 1. Is there a county or areawide comprehensive plan adopted under the Municipalities Planning Code (53 P.S. 10101 <i>et seq.</i>)? |
| <input checked="" type="checkbox"/> | <input type="checkbox"/> | 2. Is this proposal consistent with the comprehensive plan for land use? |
| <input checked="" type="checkbox"/> | <input type="checkbox"/> | 3. Does this proposal meet the goals and objectives of the plan?
If no, describe goals and objectives that are not met _____ |
| <input checked="" type="checkbox"/> | <input type="checkbox"/> | 4. Is this proposal consistent with the use, development, and protection of water resources?
If no, describe inconsistency _____ |
| <input checked="" type="checkbox"/> | <input type="checkbox"/> | 5. Is this proposal consistent with the county or areawide comprehensive land use planning relative to Prime Agricultural Land Preservation?
If no, describe inconsistencies: _____ |
| <input type="checkbox"/> | <input checked="" type="checkbox"/> | 6. Does this project propose encroachments, obstructions, or dams that will affect wetlands?
If yes, describe impact _____ |
| <input type="checkbox"/> | <input checked="" type="checkbox"/> | 7. Will any known historical or archeological resources be impacted by this project?
If yes, describe impacts _____ |
| <input type="checkbox"/> | <input checked="" type="checkbox"/> | 8. Will any known endangered or threatened species of plant or animal be impacted by the development project?
If yes, describe impacts _____ |
| <input type="checkbox"/> | <input checked="" type="checkbox"/> | 9. Is there a county or areawide zoning ordinance? |
| <input type="checkbox"/> | <input type="checkbox"/> | 10. Does this proposal meet the zoning requirements of the ordinance?
If no, describe inconsistencies <u>N/A</u> |

SECTION C. AGENCY REVIEW (continued)

Yes No

- 11. Have all applicable zoning approvals been obtained?
- 12. Is there a county or areawide subdivision and land development ordinance?
- 13. Does this proposal meet the requirements of the ordinance?
If no, describe which requirements are not met _____
- 14. Is this proposal consistent with the municipal Official Sewage Facilities Plan?
If no, describe inconsistency N/A
- 15. Are there any wastewater disposal needs in the area adjacent to this proposal that should be considered by the municipality?
If yes, describe _____
- 16. Has a waiver of the sewage facilities planning requirements been requested for the residual tract of this subdivision?
If yes, is the proposed waiver consistent with applicable ordinances.
If no, describe the inconsistencies _____
- 17. Does the county have a stormwater management plan as required by the Stormwater Management Act?
If yes, will this project plan require the implementation of storm water management measures?

18. Name, Title and signature of person completing this section:

Name: Donald E. Alexander

Title: Director, Planning

Signature: [Handwritten Signature]

Date: 03.04.2019

Name of County or Areawide Planning Agency: Northumberland County

Address: 399 Stadium Drive, Sunbury, PA 17861

Telephone Number: 570.988.4343

SECTION D. ADDITIONAL COMMENTS (See Section D of instructions)

This component does not limit county planning agencies from making additional comments concerning the relevancy of the proposed plan to other plans or ordinances. If additional comments are needed, attach additional sheets.

The county planning agency must complete this component within 60 days.

This component and any additional comments are to be returned to the applicant.

Part 2
Section 5
Public Comment Documentation

STANDARD JOURNAL

21 ARCH STREET
MILTON, PA 17847

Proof of Publication

Commonwealth of Pennsylvania
County of Northumberland

§

Personally appeared before me, the undersigned as Notary Public in and for said County and State.

Joanne Delmonico

who being duly sworn according to the law, doth depose and say that she is the

Classified Advertising
Representative

for the Standard Journal, a newspaper of general circulation published at Milton, County of Northumberland, Commonwealth of Pennsylvania, which was established January 23, 1890, and that a notice, copy of which is hereto attached, was published in said Standard Journal on

.....3-7-19.....

that affiant is not interested in the subject matter of the attached notice of advertising, and avers that all of the allegations of the statement as to the time, place, and character of the publication are true.

Joanne Delmonico

Sworn and subscribed before me this
.....18th.....day of ...April, 2019..

Karen J. Hendricks

Notary Public
COMMONWEALTH OF PENNSYLVANIA
NOTARIAL SEAL
Karen J. Hendricks, Notary Public
Milton Boro, Northumberland County
My Commission Expires Jan. 17, 2021
MEMBER, PENNSYLVANIA ASSOCIATION OF NOTARIES

Support Your Local Businesses

ADOPTION ANTIQUES/COLLECTIBLES APARTMENTS FOR RENT ARTIST'S FOR SALE AUCTION NOTICE AUTOS FOR SALE
BOATS & ACCESSORIES BUSINESS CELEBRATIONS CHILDREN'S SERVICES COMMERCIAL REAL ESTATE DUES, FUNDRAISERS FOR SALE
ELECTRICAL SERVICES FOOD & BEVERAGE GENERAL SERVICES HOME SERVICES HOME IMPROVEMENTS HOME REPAIRS
HOTELS/MOTELS MOTORCYCLES/ATV'S/UTV'S PERSONAL SERVICES PERSONAL PROPERTY FOR SALE PETS
REAL ESTATE REAL ESTATE SERVICES REAL ESTATE SERVICES REAL ESTATE SERVICES REAL ESTATE SERVICES REAL ESTATE SERVICES
REAL ESTATE SERVICES REAL ESTATE SERVICES REAL ESTATE SERVICES REAL ESTATE SERVICES REAL ESTATE SERVICES REAL ESTATE SERVICES

The Standard-Journal Classifieds

In Print and Online at www.standard-journal.com

To Place An Ad Call **570-742-9077** Today!

Legal Notices

Public Notice
In accordance with the requirements of Title 25, Chapter 71 of the Pennsylvania Code, Turberville Borough is accepting written comments over the next 30 days on an Act 537 Sewage Facilities Plan Update Special Study (Plan) for the contemplated acquisition of the Turberville Borough wastewater assets by Pennsylvania-American Water Company (PAWC), Turberville Borough currently owns and operates the sewage facilities within the Borough. The Plan incorporates the contemplated acquisition of the Turberville Borough system by PAWC, and the subsequent operation of that system by PAWC. It assures operation of the system and implementation of related Act 537 Plan provisions by a technically-competent and financially-sound entity, assuring that the Act 537 Plan objectives will continue to be met.

The Plan evaluated three alternatives to improve the performance and condition of the Turberville wastewater treatment plant (WWTP). The selected alternative is the abandonment of the existing WWTP and replacement with a new plant utilizing an extended aeration activated sludge process for continued discharge to the Unnamed Tributary to Warrior Run.

Upon publication of this notice, a 30-day review and comment period is in effect. Copies of the Plan are available for review at the office of the Borough of Turberville, 267 Broadway Street, Turberville, PA 17772, during normal hours. Interested parties can review the Plan and direct written comments to the Borough Secretary at Turberville Borough, P.O. Box 264, Turberville, PA 17772 within the 30-day review and comment period.

Borough of Turberville PA

For Home Delivery Call 570-742-9671

Legal Notices

NOTICE
The Warrior Run School District is accepting sealed bids for the following:
Music and Industrial Arts Supplies/Lumber for the 2019/2020 school year. Deadline March 18, 2019 1:00pm.
Bid specifications/RFP can be obtained online at www.wrsd.org or are available at the Business Office, 4860 Susquehanna Trail, Turberville, PA 17772. All bids must be clearly marked BID. The Warrior Run School District reserves the right to accept or reject any or all bids.

PUBLIC NOTICE

Northumberland County, on behalf of Milton Borough, intends to submit a budget modification for its FFY 2017 Community Development Block Grant (CDBG) program to the Pennsylvania Department of Community and Economic Development (PA DCEd). The County will hold a public hearing to receive comments on the budget modification on March 14, 2019 at 11:30 AM in the Northumberland County Administration Center, 399 Stadium Drive, Sunbury. The modified budget is as follows:

FFY 2017 CDBG
ACTIVITY: Curbcuts 2017 Filbert Street Current Budget \$87,791.00; Modified Budget \$00.00
ACTIVITY: Brown Street Rec Improvements 2018 Current Budget - \$00.00; Modified Budget \$87,791.00

The County will accept written public comments on the budget modification until March 14, 2019 at 11:30 AM. The County will make every effort to make all programs and activities accessible to the learning, mobility, vision, hearing, and language-impaired persons. Therefore, if you are a person with a disability or limited English proficiency, and require an auxiliary aid, service, or accommodations to participate please contact Shannon Rudy at SEDA-COG, 201 Furnace Road, Lewisburg,

Legal Notices

PA 17837. (570) 524-4491, or 1-800-332-6701, to discuss how Northumberland County can best accommodate your needs. Translators will be available upon request.
Any complaints should be written and submitted to Linda Stierling, at SEDA-Council of Governments (SEDA-COG). Written responses will be addressed within fifteen (15) working days, when practicable.

Pets

Registered chocolate and black lab puppies \$450.00 each. (570)547-6343

Help Wanted

Part-time and full-time housekeeping positions available please apply at Quality Inn New Columbia.

Nutrition Aide 2 PT positions available. Watsonstown. Apply online at www.cslu.org/jobs. Apply by 3/25/19. EOE.

Misc. Notices

ADVERTISERS
The Standard Journal assumes responsibility for any wrong insertion. It is the responsibility of the advertiser to notify us if there are any changes to be made.
Standard Journal 570-742-9671 fax: 570-742-9876

Letter policy
The Standard Journal welcomes letters to the editor and encourages the use of this forum as a means of active community involvement.

Our goal is to run all signed letters to the editor in a timely manner with as little editing as possible. We ask that letters be typed, neatly printed, or emailed, and that writers be brief, making their points concisely. Only the name and hometown of letter writers will be published in the newspaper. However, submissions must include the author's name (typed or printed), signature (written submissions), ad-

Misc. Notices

dress and telephone numbers.
We reserve the right to reject any copy or letters, but will do so only on rare occasions, typically when what is written prompts legal or ethical concerns, or when the letter is unusually lengthy. In some cases, however, we will contact writers to suggest changes that could make their letters acceptable for print.

Your opinion counts! Please write to: Letters to the Editor, The Standard-Journal 21 Arch St., Milton, PA 17847 or email newsroom@standard-journal.com

The Standard-Journal guidelines for political news coverage, letters and political advertising News and editorial coverage

1. The newspaper does not endorse candidates for local, state or national office.
2. When a person announces his or her candidacy, the newspaper will run a news story and photo at no charge.
3. The newspaper will publish news stories about write-in campaigns, provided the information is given to the newspaper in a timely manner ahead of the election.
4. Election-related news coverage beyond or in exception to what is stated above will be at the discretion of the editor in the name of reader interest and information and will be done with fairness to all candidates.

Letters to the editor
1. The newspaper does not publish letters that endorse local political candidates based on their record, reputation and qualifications. (This constitutes paid political advertising.)
2. Election-related letters must deal with pertinent issues.
3. The newspaper strongly encourages writers to limit election-related letters to 250 words. A letter to the editor from a candidate explaining that candidate's platform will be accepted. Declared candidates for contested positions will be solicited by the editor to provide their platforms as well.
4. All letters to the editor of a political nature must be received at the news-

Misc. Notices

paper office at least 10 days before the election. (Two Saturdays prior to Election Day.)
5. The exception to the 10-day rule is a response to a previous letter of an attacking or derogatory nature. In the name of fairness, the newspaper will accept such a response after the deadline, provided it is written and delivered promptly to the editor's desk. (See No. 6). Responses may rebut charges, innuendos or misstatements of fact from the initial letter, but may not present new charges or level inflammatory counterattacks on the opposing political camp.
6. Under no circumstances will any election-related letter be published after the Friday immediately prior to Election Day.
7. In the case of questionable content (e.g. statements of fact that are suspect, assaults on a candidate's character or moral standards, etc.), the newspaper will follow its established letters policy to satisfy its ethical and legal concerns. Any suggested changes to letters will be cleared with their authors.
8. All letters must be signed and include an address and telephone number. (Phone numbers are for questions and verification purposes only and will not be published).

Political advertising
1. All political advertising is charged at the prevailing open rate.
2. All political advertising must be paid for in advance.
3. All political advertising must carry a line reading "Authorized By.... or Paid For By...." If authorized by the candidate, his authorized political committee or their agents, the ad must clearly state such. If not authorized the ad must clearly and specifically state the name of the person, committee or organization who placed or financed the ad. (Personal identification may be requested.) In the case of committees, groups and organizations, they must be established, registered and/or reasonably identifiable to the newspaper's readers. If not, the name of the treasurer or another officer may be required.
4. The phrase PAID PO-

Misc. Notices

LITICAL ADVERTISE- MENT, by itself is insufficient.
5. Guaranteed position is an additional 25 percent of the cost of the ad. Subject to availability.
6. No political ads of a derogatory or attacking nature will be published after Wednesday's edition, six days prior to Election Day. (NOTE: Production deadlines require that all ads be placed with our sales department no later than 5 p.m. two working days prior to publication... or 5 p.m. Monday for an ad to appear Wednesday. In the name of fairness and our responsibility to the local voting public, responses to derogatory ads will be allowed after the Wednesday cutoff, but such ads must be placed immediately to insure placement prior to Election Day. Responses may rebut charges, innuendos or misstatements of fact from the initial ad, but may not present new charges or level inflammatory counterattacks on the opposing political camp.
7. In the case of questionable content (e.g. statements of fact that are suspect, assaults on a candidate's character or moral standards, etc.), the newspaper reserves the right to verify such information before publication or to reject the material.

Reader Notice: This newspaper will never knowingly accept any advertisement that is illegal or considered fraudulent. If you have questions or doubts about any ads on these pages, we advise that before responding or sending money ahead of time, you check with the local Attorney General's Consumer Fraud Line and/or the Better Business Bureau. Also be advised that some phone numbers published in these ads may require an extra charge. In all cases of questionable value, such as promises or guaranteed income from work-at-home programs, money to loan, etc., if it sounds too good to be true-- it may in fact be exactly that. This newspaper cannot be held responsible for any negative consequences that occur as a result of you doing business with these advertisers. Thank you

Real Estate Review

Apartments for Rent

FOR RENT: Milton 1 bedroom, 2nd floor apt. H/W/S & garbage incl., W/D hookup. Off street parking \$675 per month. + Sec. dep. No pets. No smoking. Call: 570-428-5390.

Real Estate For Sale

2408 White Deer Pike. 2 BR home on 1/2 acre bordering State Game-lands. Central air, oil heat, gas hot water. Call Jill at 570-524-2120.

All real estate advertising in this publication is subject to the Federal Fair Housing ACT of 1968 which makes it illegal to advertise "any preference, limitation or discrimination based on race, color, religion, sex, handicap, familial status, or national origin, or an intention to make any such preference, limitation or discrimination." This publication will not knowingly accept any advertising for real estate which is in violation of the law. All properties advertised in this publication are available on an equal opportunity basis. To complain of discrimination call HUD toll-free at 1-800-669-9777. All properties subject to prior changes without notice. Neither the advertiser, or the Standard Journal are responsible for any typographical errors.

To place your ad in the Real Estate Review call 570-742-9077.

Advertising Invoice

Standard Journal

2

21 N. Arch Street
Milton, PA 17847

Phone: 570-742-9671
Fax: 570-742-9876
URL:

Diane Miller
Turbotville Borough
P.O. Box 264
2 Adam Street
TURBOTVILLE PA 17772

Cust #: 01100108
Phone: (570)649-5476
Date: 03/07/2019
Due Date: 03/27/2019
Invoice #: 050542

Salesperson: **Ad Taker:** jd

Ad#	Text	Start	Stop	Ins.	Amount	Prepaid	Due
00033672	Act 537 Sewage Facilities	03/07/2019	03/07/2019	1	63.26	0.00	63.26

Please return a copy with payment

Total Due 63.26

Part 2
Section 6
Comments and Responses

Turbotville Borough

267 Broadway Street, PO Box 264 Turbotville, PA 17772
Ph. 570-649-5476 Fax 570-649-6620
turbotville5476@windstream.net

April 29, 2019

To Whom it May Concern:

On behalf of the Borough of Turbotville, I certify that no comments were received from the public following the public notice of the Act 537 Special Study that was advertised on March 8, 2019 in the Standard Journal, a newspaper of general circulation.

Sincerely,



Diane Miller
Turbotville Borough

Part 2
Section 7
Implementation Schedule

Activity	Target Date
Submission of Draft Act 537 Plan Special Study to PaDEP	11/9/18
Meet with PaDEP	11/21/18
Update special study to PaDEP Guidance	11/21/18 to 1/15/19
Prepare draft resolutions and public notice	11/21/18 to 1/15/19
Submit special Study to Turbotville Borough	1/25/2019
Submit special study to Northumberland County Health Department and Planning Commission	1/25/2019
Attend and explain special study to Turbotville Borough Council meeting	February, 2019
Advertise public notice in newspaper	3/1/19
Turbotville Borough planning commission meeting	February - March, 2019
Turbotville Borough Resolution Adoption	March, 2019
Formal submission to PaDEP	April, 2019
PaDEP Approval of Act 537 Plan Special Study	June, 2019
WWTP Design / Permitting	Remainder of 2019 to 2020
Completion of Construction of Selected WWTP Alternative	2021 to 2022

**Turbotville Borough
Act 537 Plan Update Special Study**

Part 3 – General Plan Content

Table of Contents

Introduction 1

I. Previous Wastewater Planning 1

 A. Past Wastewater Planning Impact on Current Planning Effort..... 1

 1. Previous Act 537 Planning 1

 2. Planning that Has Not Been Carried out According to Approved Plan Implementation Schedule..... 2

 3. Anticipated or Planning by Sewer Authority or Approved Under Chapter 94 Corrective Action Plan..... 2

 4. Planning Modules for New Land Development, Planning “Exemptions” and Addenda .. 2

II. Physical and Demographic Analysis..... 2

 A. Planning Area and Wastewater Service Area 2

 B. Physical Characteristics 3

III. Existing Sewage Facilities in the Planning Area 3

 A. Identify, Map, and Describe Municipal Sewage Systems in the Planning Area 3

 1. Location, Size and Ownership of Treatment Facilities, Interceptors, Pumping Stations, and Force Mains 3

 2. Treatment Process Narrative and Schematic..... 3

 3. Description of Problems with Existing Facilities 19

 4. Scheduled Treatment Facility Upgrades 19

 5. Disposal Areas 19

IV. Future Growth and Land Development..... 19

V. Identify Alternatives to Provide New or Improved Wastewater Disposal Facilities 20

VI. Evaluation of Alternatives..... 23

 A. Evaluation of WWTP Alternative 25

 1. Clean Streams Law and Clean Water Act..... 26

 2. Municipal Wasteload Management Annual Chapter 94 Reports..... 26

 3. Title II of the Clean Water Act..... 26

 4. Comprehensive Plans 26

 5. Antidegradation Requirements Contained in Chapters 93, 95, and 102 26

 6. State Water Plans..... 27

 7. Pennsylvania Prime Agricultural Land Policy 27

 8. County Stormwater Management Plans 27

 9. Wetland Protection 27

10.	Protection of Rare, Endangered or Threatened Plant and Animal Species	28
11.	Historical and Archaeological Resource Protection	28
B.	Resolution of Inconsistencies.....	29
C.	Applicable Water Quality Standards Evaluation	29
D.	Cost Estimate	30
E.	Proposed Purchase Price and Costs of Implementing Proposed Acquisition	33
F.	Analyze the Need for Immediate or Phased Implementation of the Proposed Alternative 33	
G.	Evaluate Administrative Organizations and Legal Authority Necessary for Plan Implementation.....	34
VII.	Institutional Evaluation	35
A.	Analysis and Description of Institutional Alternatives Necessary to Implement Proposed Alternatives.....	35
1.	Need for New Municipal Departments or Municipal Authorities.....	35
2.	Functions of Existing and Proposed Organizations	36
3.	Cost of Administration and Capability of Authority/Agency to Reaction to Future Needs 36	
B.	Description of Administrative and Legal Activities.....	38
1.	Incorporation of Authorities or Agencies.....	38
2.	Ordinances, Regulations, Standards, Agreements, Inter-Municipal Agreements.....	38
3.	Transfer of Rights-of-Way, Easements, and Land Transfers	39
4.	Adoption of Other Municipal Sewage Facilities Plans	40
5.	Other Legal Documents.....	40
6.	Dates or Timeframes for Items 1 to 5 Above	40
C.	Justification for Choosing Specific Institutional Alternative.....	40
VIII.	Implementation Schedule and Justification for Selected Alternatives	44
A.	Identify Technical Wastewater Disposal Alternative	44
1.	Existing Wastewater Disposal Needs	45
2.	Future Wastewater Disposal Needs	45
3.	Operation and Maintenance Considerations	45
4.	Available Management and Administrative Systems.....	45
5.	Environmental Soundness and Compliance with Natural Resources Planning and Preservation Programs	45
B.	Designate and Describe Implementation Schedule	47

List of Tables

Table 1 - Current Turbotville WWTP NPDES Effluent Limitations (June 1, 2018 to expiration date)..... 4
Table 2 - List of Permit Violations since NPDES Permit Effective Date (Sept, 2015)..... 5
Table 3 - Comparison of WWTP Alternatives 21
Table 4 - Comparison of Alternative Ability to Meet Effluent Limitations 29
Table 5 - Preliminary Opinion of Alternative A Probable Construction and Total Project Cost... 31
Table 6 - Preliminary Opinion of Alternative B Probable Construction and Total Project Cost... 32
Table 7 - Preliminary Opinion of Alternative C Probable Construction and Total Project Cost... 32

List of Figures

Figure 1 Planning Area and Wastewater Service Area
Figure 2 Collection System and Facilities
Figure 3 WWTP Process
Figure 4 Lewis Township SR54 Area
Figure 5 Alternative C Potential Location of New WWTP
Figure 6 Alternative C Design Concept

List of Appendices

Appendix A – 2017 Special Study
Appendix B – NPDES Permit
Appendix C – Wasteload Management Report
Appendix D – Phosphorous Removal Pilot Study Documentation
Appendix E – MOU between PAWC and Lewis Township
Appendix F – Completed and Signed copy of the PNDI
Appendix G – Cultural Resources Notice and PHMC Review

Introduction

This Act 537 Plan Update Special Study is being prepared pending the acquisition of Turbotville Borough wastewater system by Pennsylvania-American Water Company (PAWC). As documented by this Act 537 Plan Update Special Study, the contemplated acquisition of the Turbotville Borough wastewater system by PAWC, and the subsequent operation of that system by PAWC, assures operation of the system and implementation of related Act 537 Plan provisions by a technically-competent and financially-sound entity, assuring that the Act 537 Plan objectives will continue to be met. The Act 537 planning area / proposed PAWC certificated franchise territory is shown in Figure 1. Figure 2 shows the location of existing Turbotville Borough wastewater facilities.

On June 29, 2018 Turbotville Borough executed an Asset Purchase Agreement (APA) with PAWC. The Pennsylvania Public Utilities Commission (PUC) application was filed August 20, 2018. Upon closing of the proposed transaction, PAWC would assume the operation and management of the existing wastewater collection and treatment facilities currently owned by Turbotville Borough. This Act 537 Plan Update Special Study (1) evaluates the administrative and financial capabilities of PAWC and PAWC's ability to successfully operate and maintain Turbotville Borough's sewage collection and treatment system, (2) sets forth the allocation of responsibilities and process for implementation of the Act 537 Plan's requirements, and (3) discusses "General Plan Content" items that are relevant to the scope and objective of this Act 537 Plan Update. This Special Study addresses the institutional arrangements for ownership and operation of the Turbotville Borough system, and this plan provides an alternatives analysis for the Turbotville wastewater treatment plant (WWTP).

I. Previous Wastewater Planning

A. Past Wastewater Planning Impact on Current Planning Effort

1. Previous Act 537 Planning

A 1984 report prepared by Buchart-Horn, Inc. titled "Preliminary Engineering Report and Updated Official Plan (Act 537) Sanitary Sewerage Facilities" serves as the most recent adopted plan, or "base plan" for Turbotville Borough. An April 2017 report prepared by Uni-Tec Consulting Engineers, Inc. titled "Act 537 Special Study Wastewater Treatment Plant" was approved by the Pennsylvania Department of Environmental Protection (PaDEP). The Water Quality Management Permit associated with the recommended alternative of the 2017 Special Study was submitted but later withdrawn at the request of Turbotville Borough. The 2017 Special Study is included in Appendix A.

Previous studies have evaluated sewer system regionalization. These include the March, 2009 "Northern Neighbors Act 537 Plan" prepared by HRG and the August, 2006 "Northern Northumberland County, Pennsylvania, Wastewater Regionalization Study" prepared for the Milton Regional Sewer Authority by the U.S. Army Corps of Engineers. A regionalization

alternative was evaluated in the 2017 Special Study, but regionalization was not the selected alternative. PAWC has no plans at this time for regionalized wastewater service, and plans to continue operating Turbotville as a standalone wastewater system after the asset acquisition.

2. Planning that Has Not Been Carried out According to Approved Plan Implementation Schedule

The chosen alternative in the 2017 Act 537 Special Study was to construct a new sequencing batch reactor (SBR) WWTP. A 10/10/2017 letter from PaDEP to Francis Betz of Turbotville Borough states: "As discussed during our meeting on September 11, 2017, Turbotville's Act 537 Plan requires construction of the referenced wastewater treatment facility as approved under the 2017 Special Study. Until an alternative Act 537 Plan is approved, this remains the required path forward."

The 2017 Act 537 Special Study selected alternative has not been carried out by Turbotville Borough. Presented in this Act 537 Special Study is an alternatives analysis that uses the latest information, including the phosphorous removal / precipitation pilot study. The recommended alternative in this Special Study is intended to replace previous planning (2017 Special Study) regarding the Turbotville WWTP and outlines a roadmap to compliance for PAWC as the new owner of the Turbotville WWTP.

3. Anticipated or Planning by Sewer Authority or Approved Under Chapter 94 Corrective Action Plan

No planning is anticipated related to an approved Chapter 94 Corrective Action Plan.

4. Planning Modules for New Land Development, Planning "Exemptions" and Addenda

Sewage Planning Exemption was received September 6, 2007 for Wellington Estates Subdivision, containing 12 lots to be serviced by the public sewer system in Turbotville Borough.

II. Physical and Demographic Analysis

A. Planning Area and Wastewater Service Area

The Turbotville Borough wastewater system currently serves 269 customer connections, comprised of 243 residential, 20 commercial, and 6 institutional customer connections (count as of 6/30/18). Of these, approximately 53 accounts are not connected to public water. All customers are located within Turbotville Borough, Northumberland County, Pennsylvania.

Figure 1 depicts the Act 537 planning area which is the same as the PAWC proposed certificated franchise territory. The wastewater service territory is located entirely within Turbotville Borough.

B. Physical Characteristics

Turbotville Borough is a small rural community surrounded by Lewis Township, located at the northern tip of Northumberland County. The Borough owns and operates a WWTP located in the northwest quadrant of Turbotville. WWTP effluent is discharged to an Unnamed Tributary to Warrior Run. Warrior Run discharges into the West Branch Susquehanna River.

The 1984 base plan, as well as the 2017 Act 537 Special Study (Appendix A) that was submitted and approved, contain more detailed background information regarding physical characteristics and related topics such as soils, geologic features, and topography.

III. Existing Sewage Facilities in the Planning Area

A. Identify, Map, and Describe Municipal Sewage Systems in the Planning Area

1. Location, Size and Ownership of Treatment Facilities, Interceptors, Pumping Stations, and Force Mains

The Turbotville Borough wastewater system, which is shown in Figure 2, provides wastewater collection and treatment services to 269 customer connections. The Turbotville wastewater system does not currently supply any customers through bulk service connections. There are no pumping stations in the collection system.

The collection system consists of approximately 3.97 miles of 6-inch and 8-inch sewers. Approximately two-thirds of the collection system was slip-lined in the 1990's; most of the remaining pipes are vitrified clay pipe. The entire collection system drains by gravity to the WWTP. A pumping station is located at the headworks of the WWTP. There are no combined sewers or permitted overflows.

2. Treatment Process Narrative and Schematic

The Turbotville WWTP schematic is shown in Figure 3. All wastewater generated in the Borough flows to the WWTP. Flow passes through a 300 gpm comminution chamber which includes a 45 degree, two-inch clearance manual by-pass bar screen. Wastewater then collects in the wet well of a 0.25 MGD duplex submersible pump station which discharges into the adjacent flow splitter box. Gate valves can be used to isolate a treatment train and divert all flow to a single treatment train. Normally, valves are fully open to split flow evenly between two treatment trains.

The primary effluent proceeds into two 50,000-gallon aeration tanks where biological treatment occurs. Sludge recirculated from the secondary settling basins is mixed with raw wastewater and air is introduced via non-clogging coarse bubble diffusers to provide treatment. Mixed liquor from the aeration tanks flows directly into two 16,700-gallon secondary settling basins where the mixed

liquor suspended solids from the aeration tanks is settled out. The settled sludge is either returned back to the head of the aeration tanks or wasted from the process.

Secondary settling basin effluent flows by gravity into two 2,100-gallon chlorine contact tanks and is disinfected with chlorine erosion tablets. Chlorine contact effluent flows through the 980-gallon final effluent flow metering chamber and is discharged to an unnamed tributary of Warrior Run.

Sludge wasted from the activated sludge process is pumped via two 3-inch air lift pumps located in the secondary settling basin to a 29,700 gallon aerobic digestion tank. Stabilization and thickening occurs in the aerobic digestion tank. The thickened stabilized sludge is pumped to the sludge drying beds where it is dewatered, removed and hauled to an approved landfill. During the winter months the drying beds are not used because of the freezing temperatures, and Turbotville uses contract haulers to haul liquid sludge to other WWTPs for further treatment and disposal.

The WWTP operates under NPDES permit PA0028100 which expires August 31, 2020. The NPDES Permit is included in Appendix B. Permitted capacity of the WWTP is 0.136 MGD. The NPDES permit includes two separate effluent limitation tables covering two time periods between the effective date and expiration date. On June 1, 2018, new effluent limitations went into effect for Total Phosphorous and Total Copper, and more stringent effluent limitations went into effect for Ammonia-Nitrogen. Current NPDES effluent limits are listed in Table 1. Each parameter is discussed below. Table 2 lists effluent violations since the NPDES permit effective date of September 1, 2005. Data was obtained from discharge monitoring reports (DMRs).

Table 1 - Current Turbotville WWTP NPDES Effluent Limitations (June 1, 2018 to expiration date)

Parameter	Mass Units (lbs/day)		Concentrations (mg/L)			
	Average Monthly	Weekly Average	Minimum	Average Monthly	Weekly Average	Instant. Maximum
Flow (MGD)	Report	Report Daily Max	-	-	-	-
pH	-	-	6.0	-	-	9.0
Dissolved Oxygen	-	-	Report	-	-	-
Total Residual Chlorine	-	-	-	0.45	-	1.48
CBOD5	13	20	-	12	18	24
BOD5 Raw Sewage Influent	Report	Report Daily Max	-	Report	-	-
Total Suspended Solids Raw Sewage Influent	Report	Report Daily Max	-	Report	-	-
Total Suspended Solids	34	34	-	30	30	30
Fecal Coliform (CFU/100 mL) May 1 – Sep 30	-	-	-	200 Geo Mean	-	1,000
Fecal Coliform (CFU/100 mL) Oct 1 – Apr 30	-	-	-	2,000 Geo Mean	-	10,000

Parameter	Mass Units (lbs/day)		Concentrations (mg/L)			
	Average Monthly	Weekly Average	Minimum	Average Monthly	Weekly Average	Instant. Maximum
Ammonia-Nitrogen May 1 – Oct 31	4.0	5.5	-	3.5	5.0	7.0
Ammonia-Nitrogen Nov 1 – Apr 30	11.5	17	-	10.5	15	21
Total Phosphorous	2.96	2.96	-	2.60	2.60	2.60
Total Copper (µg/L)	0.04	0.08 Daily Max	-	36.31 µg/L	72.62 µg/L Daily Max	90.77 µg/L
Total Lead	Report	Report Daily Max	-	Report	Report Daily Max	-

Table 2 - List of Permit Violations since NPDES Permit Effective Date (Sept, 2015)

Non-Compliance ID	Month	Parameter	Limit Type	Reported Value	Permit Limit	Unit	Cause listed in DMR
36730	Oct 2016	NH3-N	Weekly Average	9.6	9	lbs/day	
54629	Feb 2018	TSS	Weekly Average	90	34	lbs/day	Hydraulic flow exceeding plant or unit design
54631		TSS	Average Monthly	<33	30	mg/L	Hydraulic flow exceeding plant or unit design
54633		TSS	Weekly Average	108	30	mg/L	
54630		CBOD5	Weekly Average	21	20	lbs/day	Hydraulic flow exceeding plant or unit design
54532		CBOD5	Average Monthly	15	12	mg/L	
54634		CBOD5	Weekly Average	25	18	mg/L	
58397	May 2018	CBOD5	Weekly Average	29	20	lbs/day	Hydraulic flow exceeding plant or unit design
69872	July 2018	CBOD5	Weekly Average	22	20	lbs/day	Hydraulic flow exceeding plant or unit design
69873		Fecal Coliform	Instantaneous Maximum	>2,420	1,000		Insufficient / Overdose chemical feed
71605	August 2018	NH3-N	Average Monthly	5	4	lbs/day	Hydraulic flow exceeding plant or unit design
71606		NH3-N	Weekly Average	9	5.5	lbs/day	Hydraulic flow exceeding plant or unit design
71607		NH3-N	Average Monthly	4	3.5	mg/L	Hydraulic flow exceeding plant or unit design
71608		NH3-N	Weekly Average	6	5	mg/L	Hydraulic flow exceeding plant or unit design

Flow

Exhibit 1 shows average monthly and daily maximum flow measured at the Turbotville WWTP influent and reported monthly in the DMRs. Since the current NPDES permit effective date, average monthly flow into the WWTP has ranged from 0.029 MGD to 0.128 MGD with an average of 0.0574 MGD. Daily maximum flow up to six times the average monthly flow has been reported. According to the 2018 Chapter 94 Wasteload Management Report, the WWTP is not currently nor projected to be in hydraulic overload condition, using Chapter 94 methodology which considers if the monthly average exceeds the design hydraulic capacity of the WWTP three consecutive calendar months. However, infiltration and inflow (I&I) in the collection system has resulted in high daily maximum flows. High daily flows due to I&I was a contributing factor for most NPDES permit exceedances, which are described below and listed in Table 2. The Chapter 94 Wasteload Management Report is included in Appendix C.

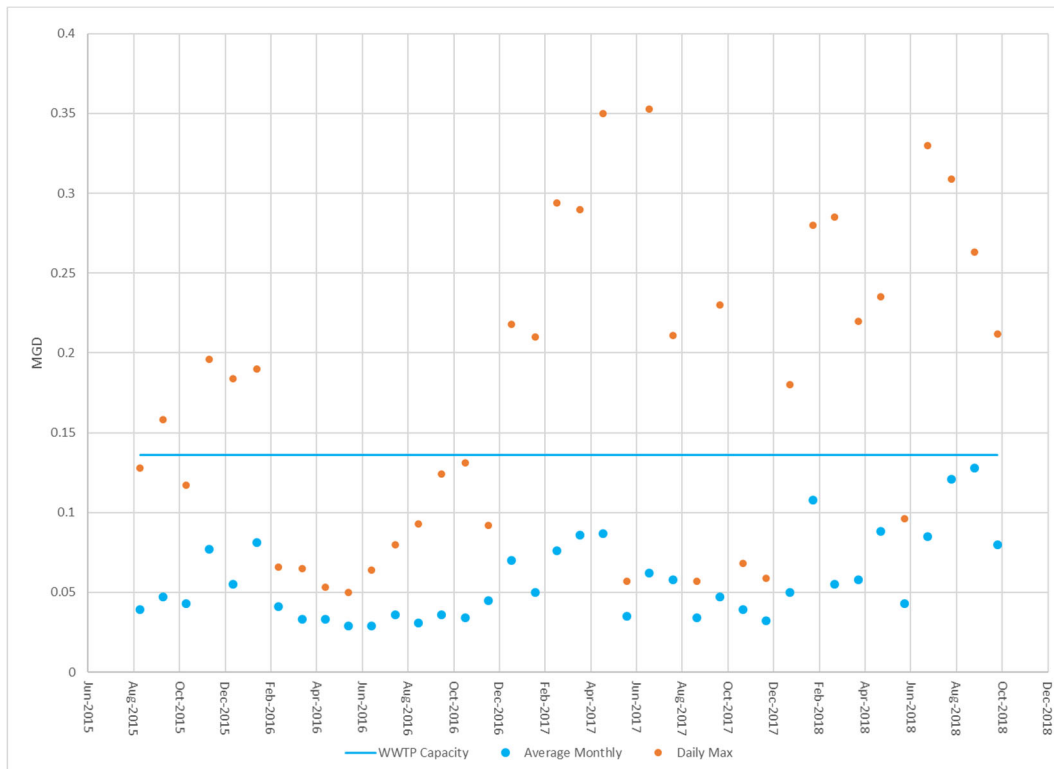

Exhibit 1 - Turbotville WWTP Influent Flow

pH

Effluent pH has been within NPDES permit limits as shown in Exhibit 2. Minimum pH has ranged from 6.6 to 7.2 with an average of 7.1. Maximum pH has ranged from 7.2 to 7.7 with an average of 7.4.

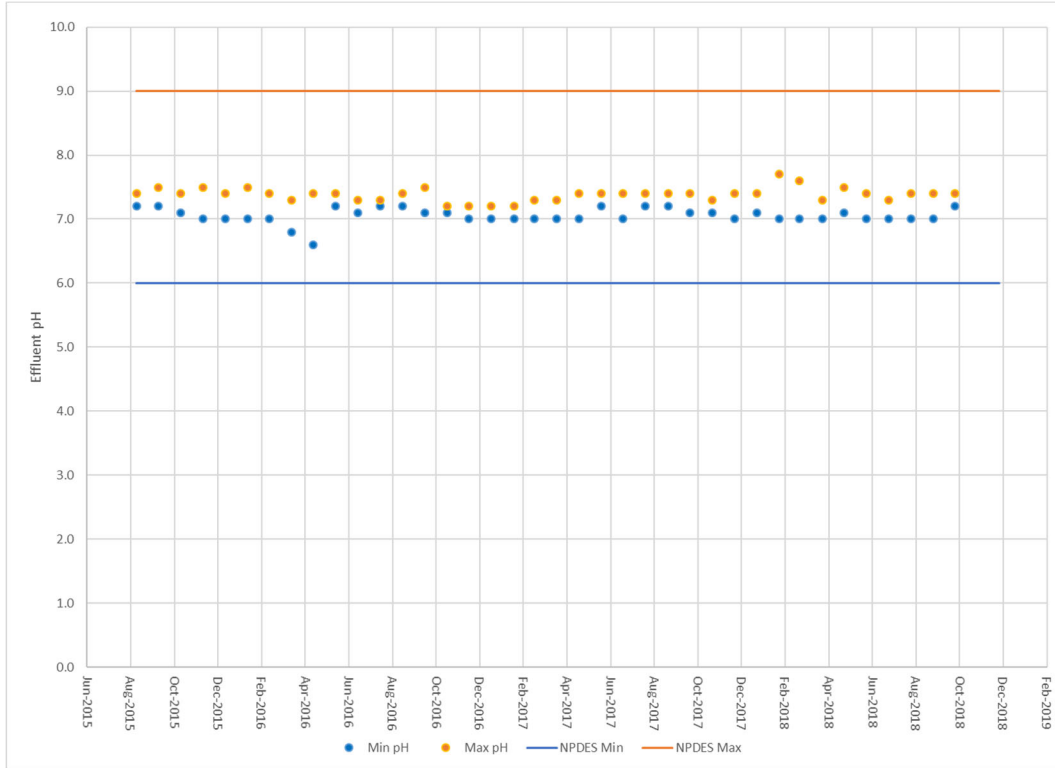

Exhibit 2 - Effluent pH

Total Residual Chlorine

Total residual chlorine concentrations have been below NPDES permit limits as shown in Exhibit 3. Average monthly effluent chlorine has ranged from 0.22 to 0.38 mg/L with an average of 0.29 mg/L. Instantaneous maximum effluent chlorine has ranged from 0.36 to 0.91 mg/L with an average of 0.68 mg/L.

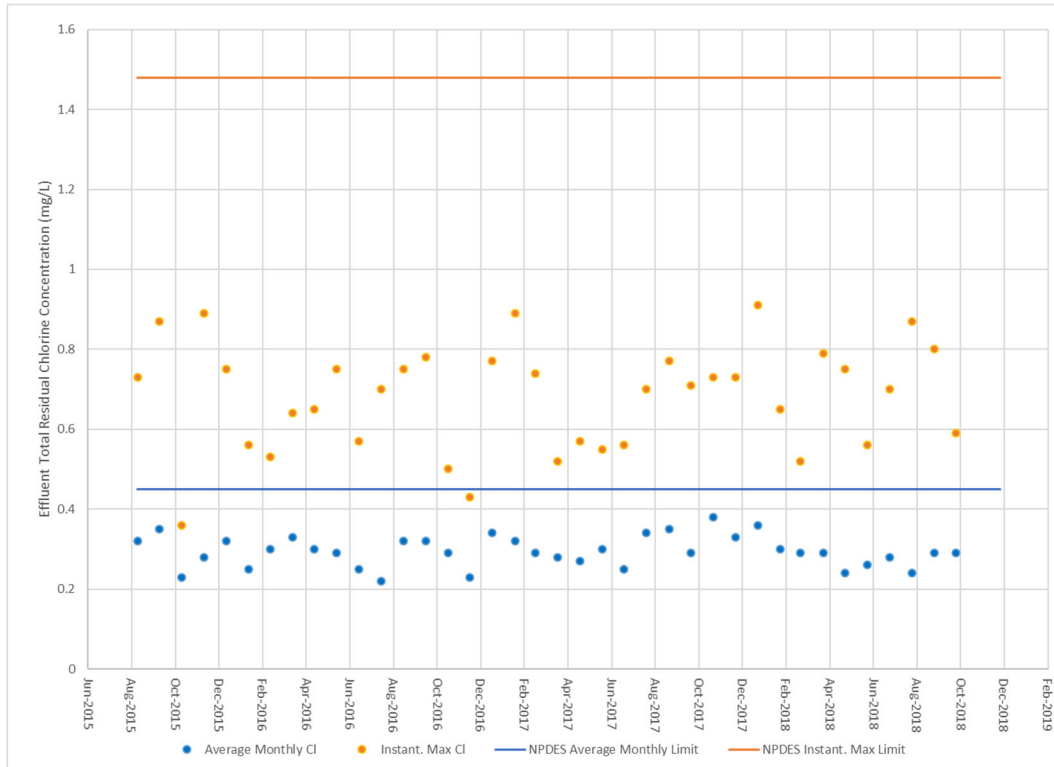

Exhibit 3 - Effluent Total Residual Chlorine

Carbonaceous Biochemical Oxygen Demand (CBOD5)

Effluent CBOD5 mass load and concentration are shown in Exhibit 4 and Exhibit 5, respectively. Average monthly mass load has ranged from 0.8 to 12 lbs/day with an average of 2.52 lbs/day. Weekly average mass load has ranged from 1 to 29 lbs/day with an average of 5.71 lbs/day. Average monthly effluent concentration has ranged from 3 to 15 mg/L with an average of 4.76 mg/L. Weekly average concentration has ranged from 3 to 25 mg/L with an average of 7 mg/L.

In February, 2018, the weekly average CBOD5 of 21 lbs/day exceeded the permit limit of 20 lbs/day; the average monthly concentration of 15 mg/L exceeded the permit limit of 12 mg/L; and the weekly average concentration of 25 mg/L exceeded the permit limit of 18 mg/L. Weekly average CBOD5 mass loadings of 29 lbs/day and 22 lbs/day in May and July, 2018, respectively, exceeded the permitted value of 20 lbs/day. The cause of non-compliance stated in the DMRs is "Hydraulic flow exceeding plant or unit design."

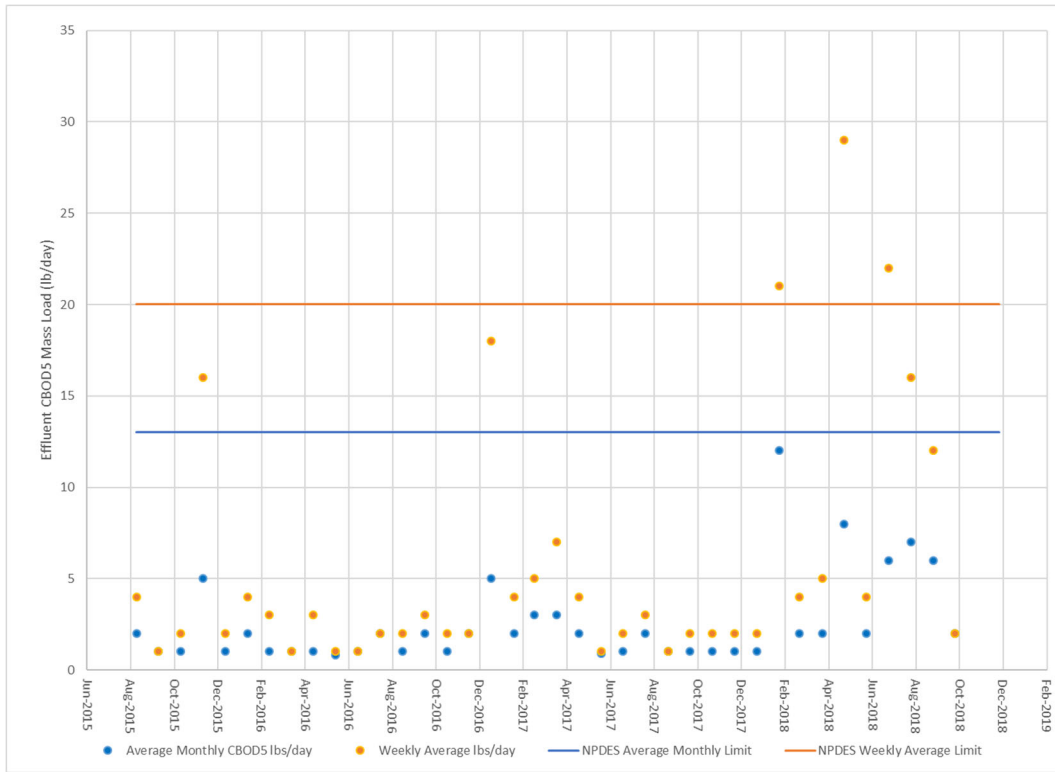

Exhibit 4 - Effluent CBOD5 Mass Load

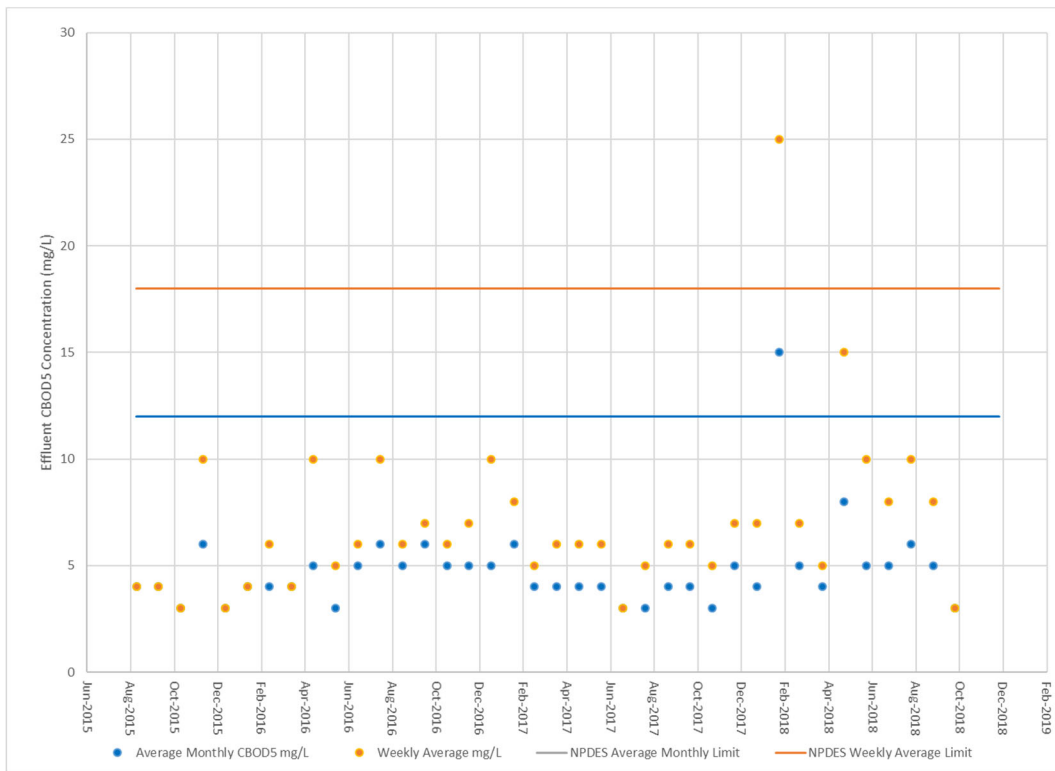

Exhibit 5 - Effluent CBOD5 Concentration

Total Suspended Solids (TSS)

Effluent TSS mass loading and concentration are shown in Exhibit 6 and Exhibit 7, respectively. Average monthly mass loading has ranged from 1 to 27 lbs/day with an average of 3.45 lbs/day. Weekly average mass loading has ranged from 1 to 90 lbs/day with an average of 8.13 lbs/day. Average monthly concentration ranged from 1 to 33 mg/L with an average of 4.92 mg/L. Weekly average concentration ranged from 5 to 108 mg/L with an average of 10.03 mg/L.

In February, 2018, the weekly average TSS of 90 lbs/day exceeded the permit limit of 34 lbs/day, the average monthly concentration of 33 mg/L exceeded the permit limit of 30 mg/L, and the weekly average concentration of 108 mg/L exceeded the permit limit of 30 mg/L. The February, 2008 DMR lists “Hydraulic flow exceeding plant or unit design” as the cause of non-compliance.

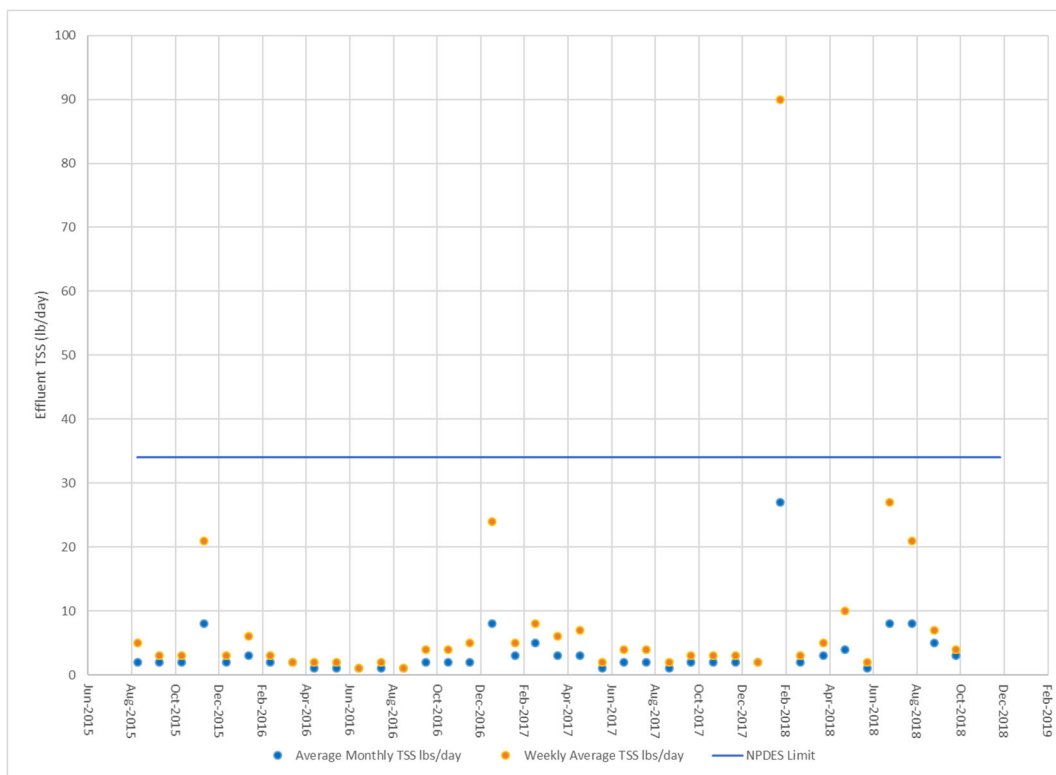

Exhibit 6 - Effluent TSS Mass Loading

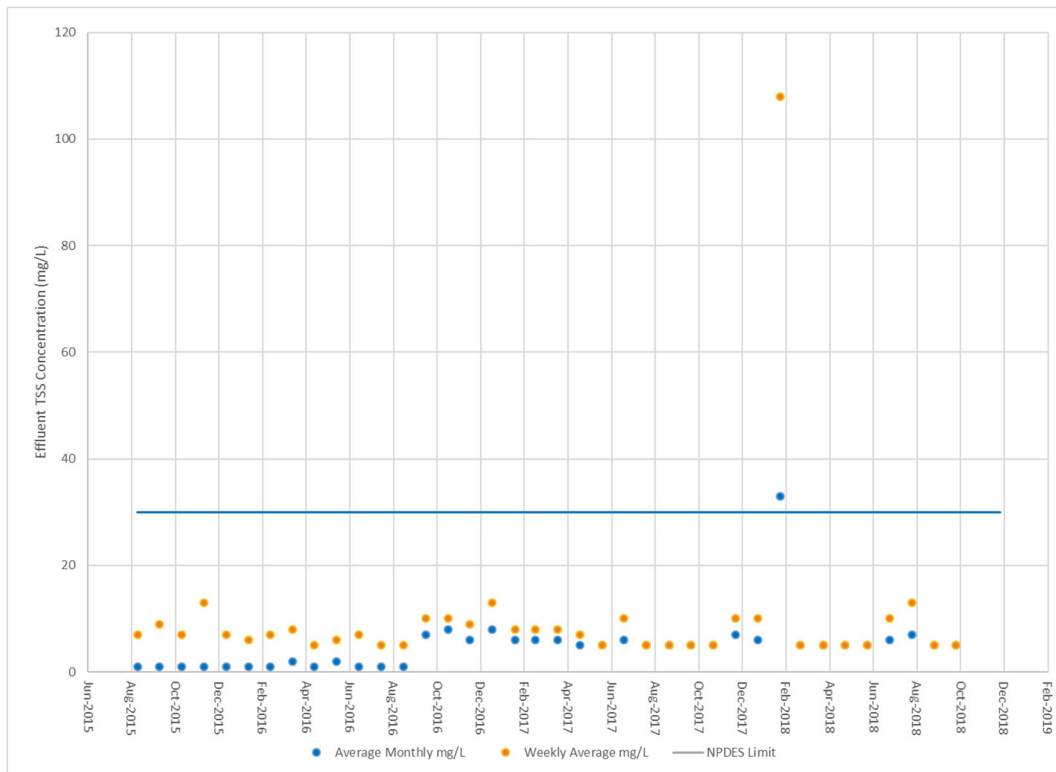

Exhibit 7 - Effluent TSS Concentration

Fecal Coliform

Average monthly and maximum instantaneous fecal coliform (CFU/100 mL) are shown in Exhibit 8 and Exhibit 9, respectively. Average monthly fecal coliform ranges from 1 to 110 CFU/100 mL with an average of 15.84 CFU/100 mL. Instantaneous maximum fecal coliform ranges from 2 to >2,420 CFU/100 mL with an average of 306 CFU/100 mL. In July, 2018, instantaneous maximum fecal coliform of >2420 exceeded the permit limit of 1,000. The cause of non-compliance is listed as “insufficient / overdose of chemical feed.”

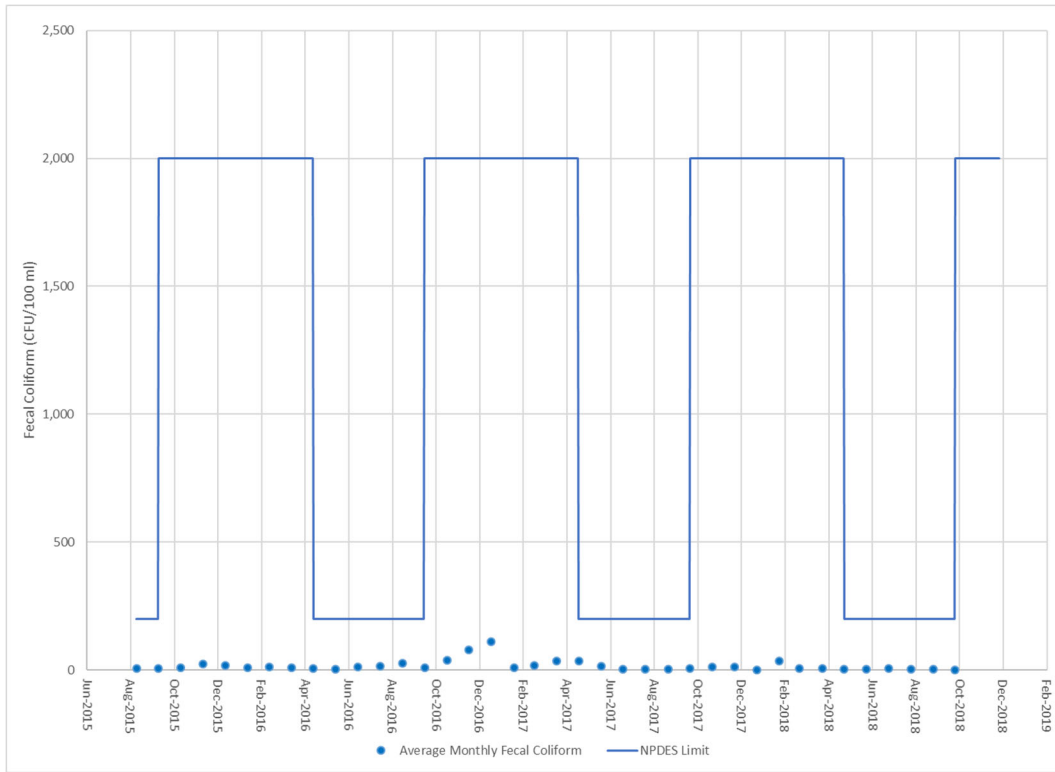

Exhibit 8 - Average Monthly Fecal Coliform

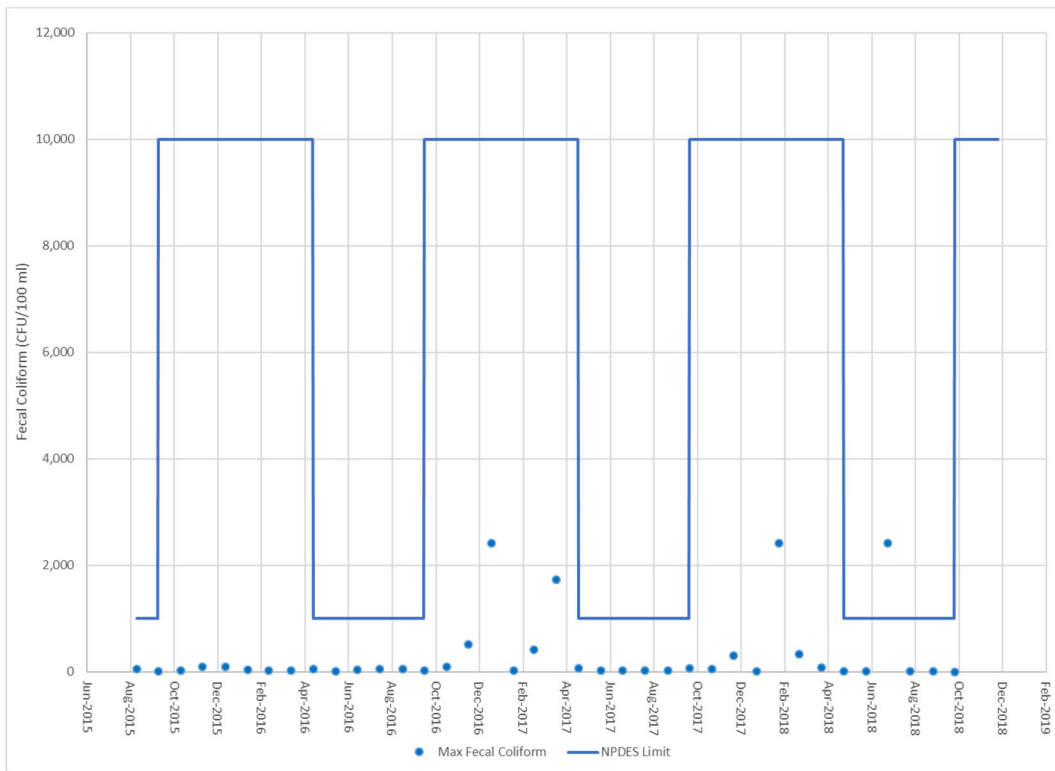

Exhibit 9 - Maximum Fecal Coliform

Ammonia-Nitrogen

Average monthly and average weekly ammonia-nitrogen effluent mass load are shown in Exhibit 10 and Exhibit 11, respectively. Lower limits went into effect on 6/1/18. Average monthly and average weekly ammonia-nitrogen concentrations are shown in Exhibit 12 and Exhibit 13, respectively. Average monthly mass load ranged from 0.1 to 5 lbs/day with an average of 0.76 lbs/day. Weekly average mass loading ranged from 0.2 to 9 lbs/day with an average of 1.6 lbs/day. Average monthly concentration ranged from 1 to 5 mg/L with an average of 1.47 mg/L. Weekly average concentration ranged from 1 to 15.1 mg/L with an average of 2.86 mg/L.

In August, 2018, average monthly ammonia-nitrogen load of 5 lbs/day exceeded the permit limit of 4.0 lbs/day; weekly average mass load of 9 lbs/day exceeded the permit limit of 5.5 lbs/day; average monthly concentration of 4 mg/L exceeded the permit limit of 3.5 mg/L; and average weekly concentration of 6 mg/L exceeded the permit limit of 5.0 mg/L. The cause of non-compliance listed in the DMR is “hydraulic flow exceeding plant or unit design.” Operator comment notes “due to the high flows we had the air turned off for too long. The plant has since comeback within limits.”

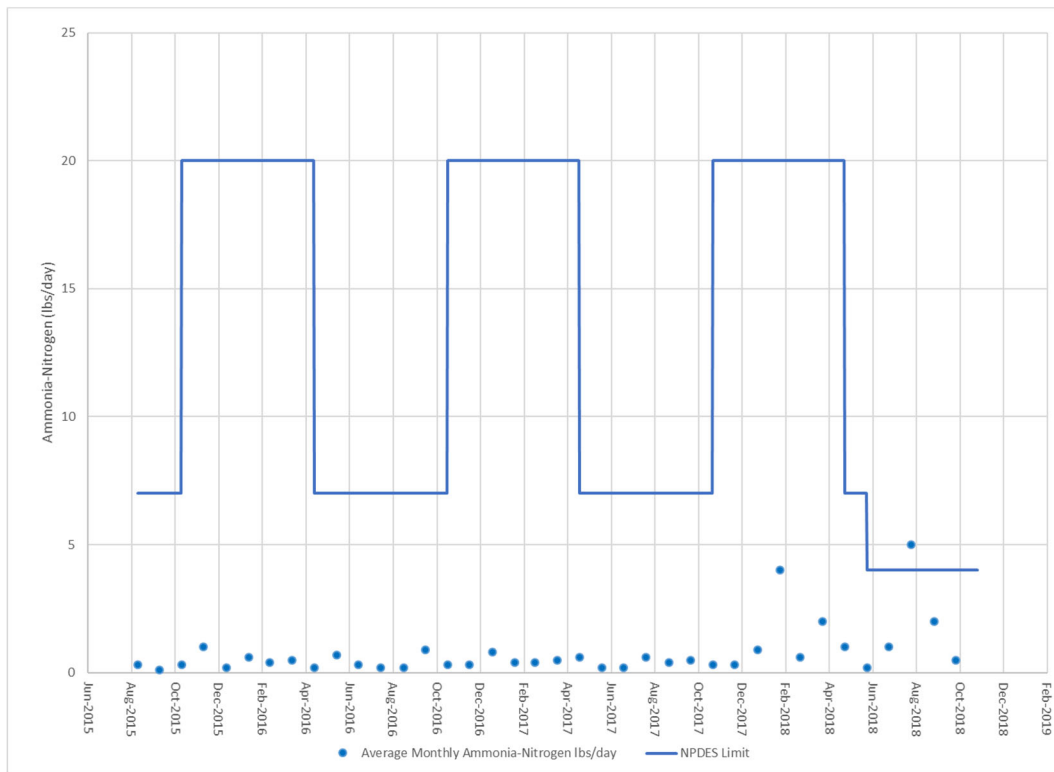

Exhibit 10 - Average Monthly Ammonia-Nitrogen Mass Load

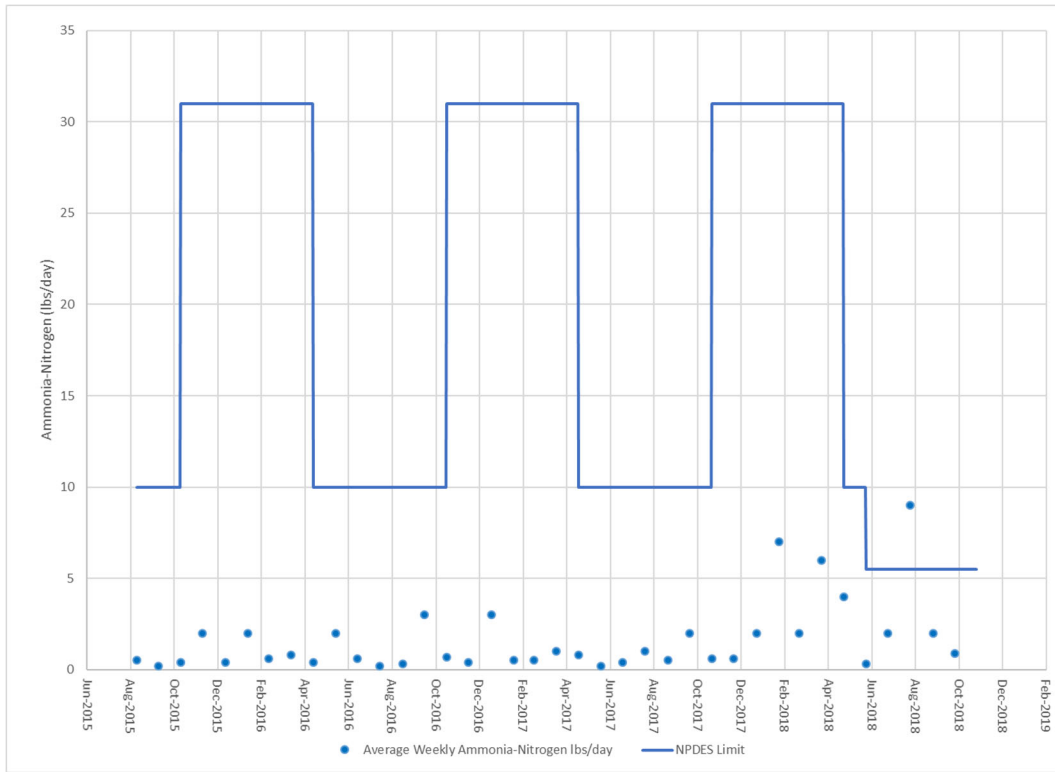

Exhibit 11 - Average Weekly Ammonia-Nitrogen Mass Load

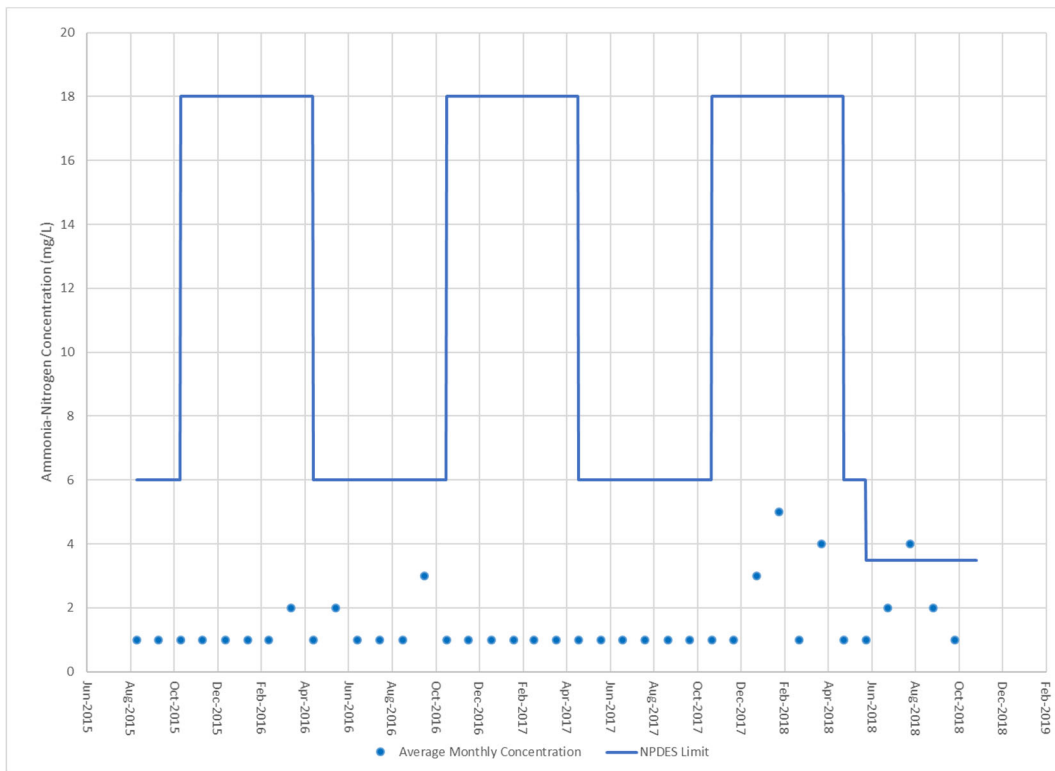

Exhibit 12 - Average Monthly Ammonia-Nitrogen Concentration

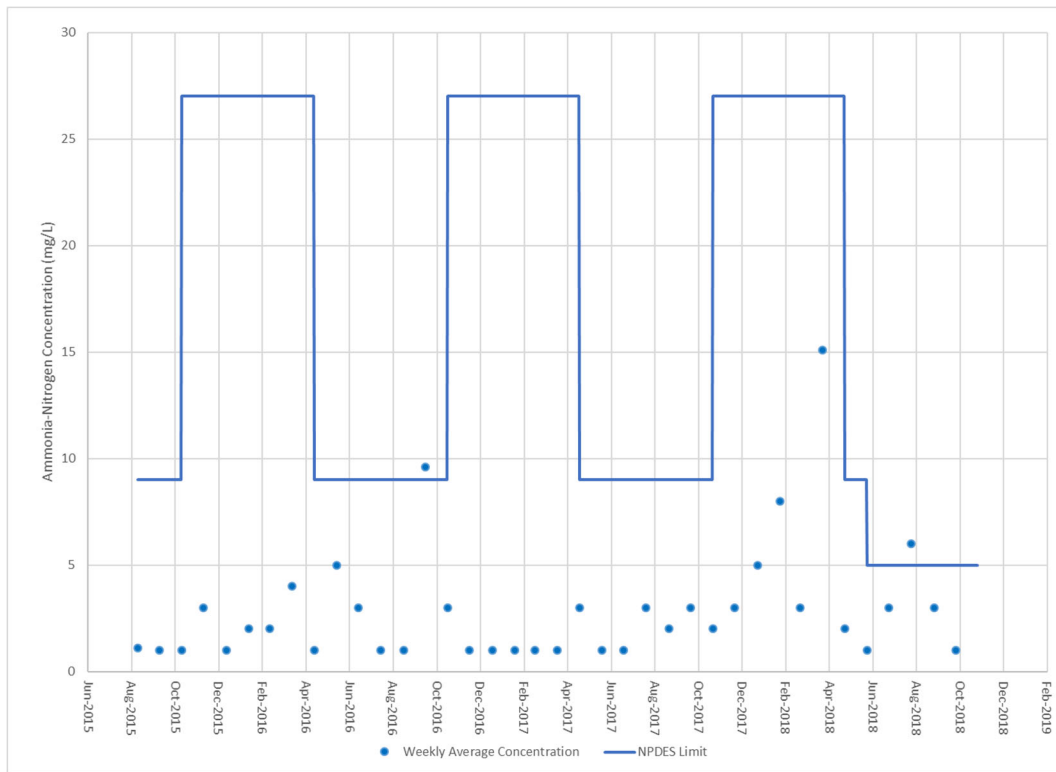

Exhibit 13 - Average Weekly Ammonia-Nitrogen Concentration

Total Phosphorous

Total phosphorous mass load and concentration are shown in Exhibit 14 and Exhibit 15, respectively. Average monthly load ranged from 0.04 to 1 lbs/day (0.04 to 0.5 lbs/day since 6/1/18) with an average of 0.74 lbs/day. Average weekly load ranged from 0.09 to 4 lbs/day (0.09 to 2 lbs/day since 6/1/18) with an average of 1.37 lbs/day. Average monthly concentration ranged from 0.14 to 3.65 mg/L (0.14 to 0.422 mg/L since 6/1/18) with an average of 2.05 mg/L. Average weekly concentration ranged from 0.25 to 5.48 mg/L (0.25 to 1.06 mg/L since 6/1/18) with an average of 2.87 mg/L. There have been no exceedances since effluent limitations went into effect on 6/1/2018, which is thought to be the result of liquid alum addition related to the phosphorous removal pilot study.

Per a 5/31/18 letter from PaDEP to Francis Betz of Turbotville Borough, Turbotville Borough was permitted to conduct a pilot test of a phosphorous removal / precipitation system. The pilot study authorization coincided with new effluent limits, which went into effect on 6/1/2018. A final report / memorandum on the pilot test's effectiveness was prepared by Turbotville Borough's Engineer Uni-Tec and sent to PaDEP on 11/27/18. Pilot study results indicated that liquid alum addition removed most of the phosphorous and the Turbotville WWTP met the new lower total phosphorous effluent limitations during the pilot study. An extension was requested due to data inconsistencies and to allow further data collection to better define dosage rates. A 12/3/18 letter from PaDEP to Turbotville Borough states "[t]he temporary authorization ended on October 31, 2018, and no further authorization to utilize this "pilot" process is granted." A Water Quality Management (WQM) Permit has been filed by the Borough to permit the use of the phosphorous

removal system. If this WQM is granted, the permit would be transferred to the new owner (PAWC) upon acquisition of the wastewater system. After the acquisition, PAWC intends to operate the phosphorous removal system until the new WWTP is constructed and placed in service. Pilot study information is included in Appendix D.

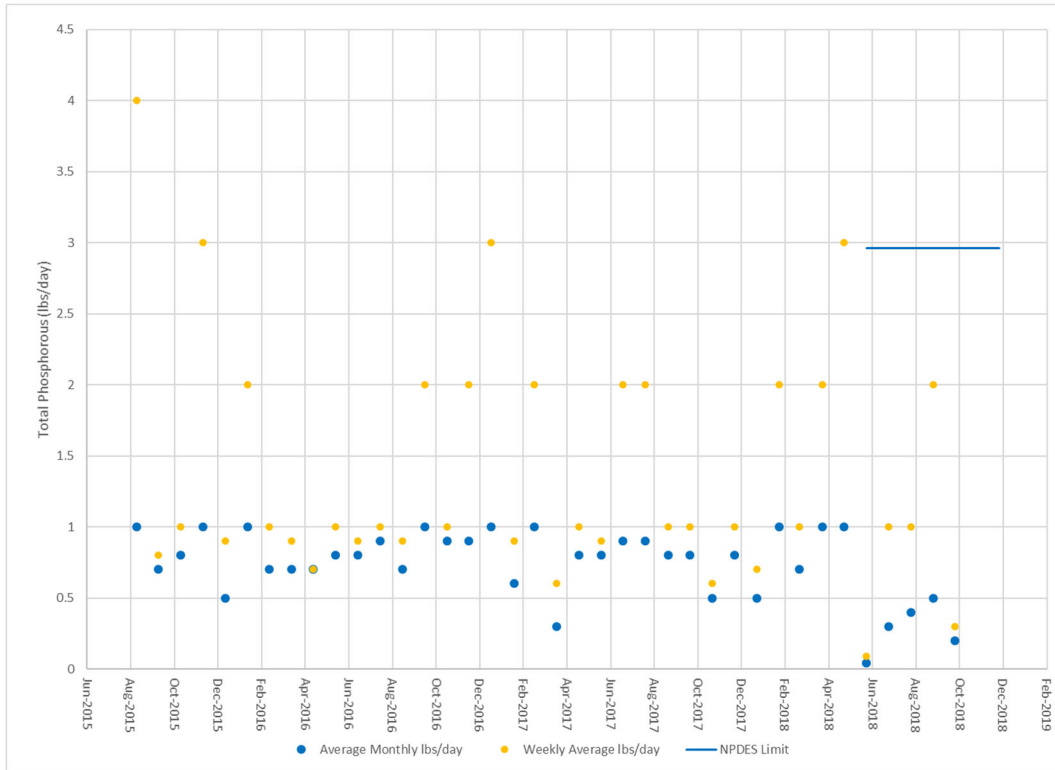

Exhibit 14 - Total Phosphorous Mass Load

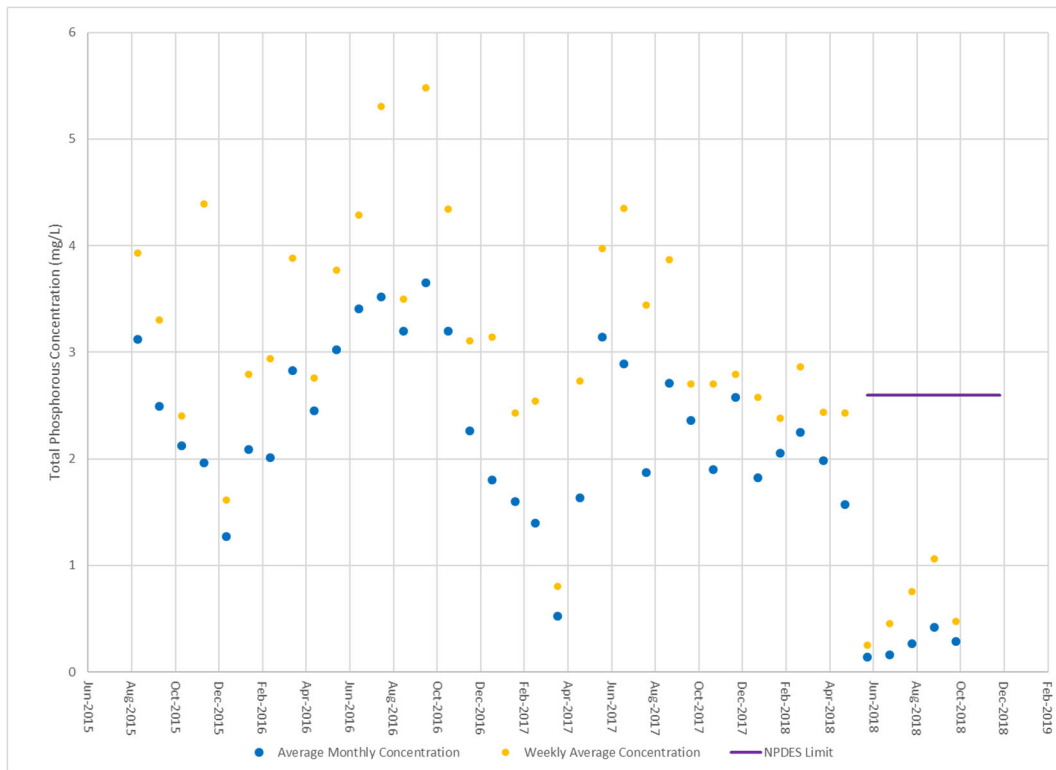

Exhibit 15 - Total Phosphorous Concentration

Total Copper

Total copper effluent mass load and concentration are shown in Exhibit 16 and Exhibit 17, respectively. New effluent limits went into effect on 6/1/18. Average monthly total copper mass load ranged from 0.0009 to 0.3 lbs/day with an average of 0.0129 lbs/day. Daily maximum copper mass load ranged from 0.0009 to 0.02 lbs/day with an average of 0.00523 lbs/day. Average monthly concentration ranged from 0.005 to 0.04 mg/L with an average of 0.0139 mg/L.

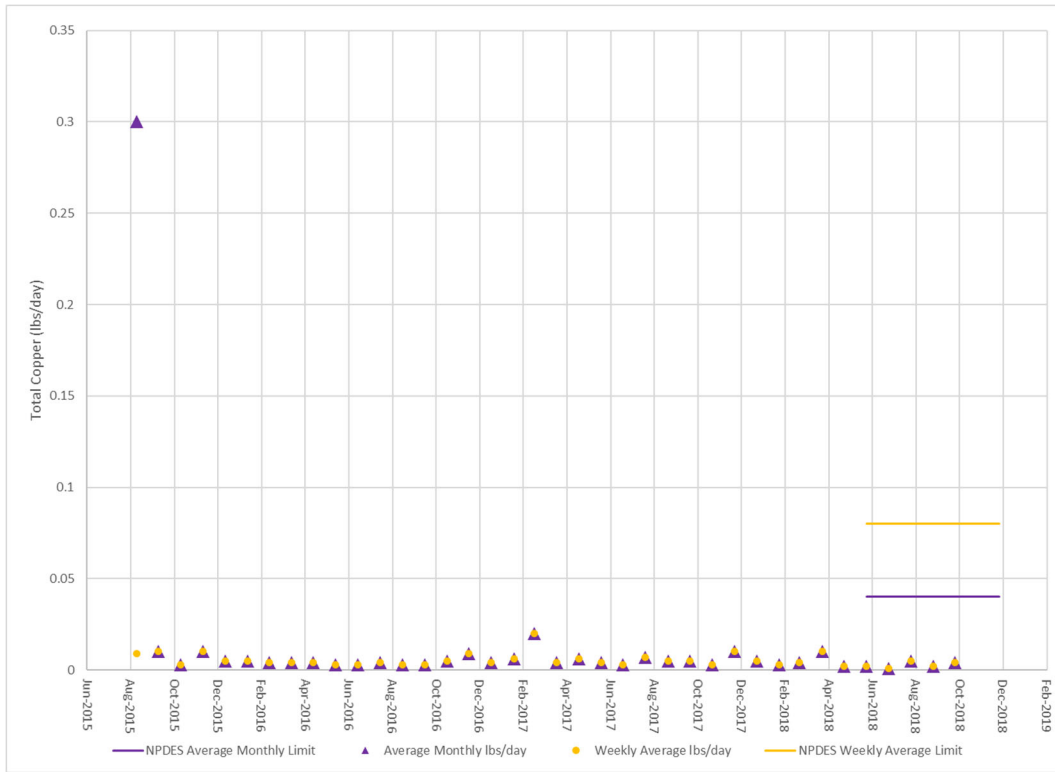

Exhibit 16 - Total Copper Effluent Mass Load

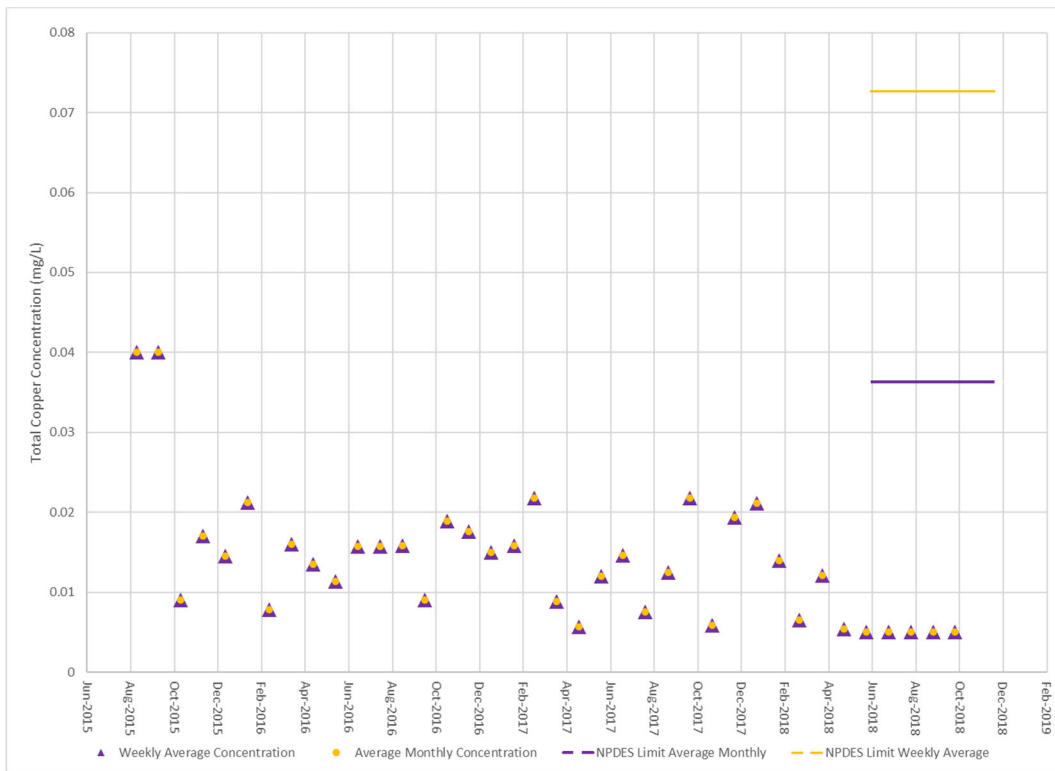

Exhibit 17 - Total Copper Effluent Concentration

3. Description of Problems with Existing Facilities

- The WWTP is not designed to meet current effluent requirements for total phosphorous concentration.
- The WWTP is not currently nor projected to be in hydraulic overload conditions; however, I&I in the collection system results in high daily flow rates which have contributed to exceedances in NPDES effluent limits for TSS, CBOD5, Ammonia-Nitrogen, and Fecal Coliform.
- The influent pump station capacity is insufficient for max daily flow rates due to I&I
- Various WWTP components are in poor condition. Examples include: steel tanks with visual rust spots consistent with age, metal grate coverings for steel tanks are deteriorated or missing and present a safety hazard, metal components and piping inside influent pump station show signs of rust and deterioration consistent with age.

4. Scheduled Treatment Facility Upgrades

See Sections V and VI below for identification of alternatives and analysis of alternatives.

5. Disposal Areas

The WWTP does not use any disposal for effluent other than the outfall into the Unnamed Tributary of Warrior Run.

IV. Future Growth and Land Development

Borough population increased from 691 to 705 between 2000 and 2010 and is projected to increase to 720 in 2020 and 735 in 2030 according to PaDEP's 2010 to 2040 Population Projection Report. In 2007, PaDEP granted the Borough an exemption for Wellington Estates, which is a 12-lot, single family, residential subdivision being served by public water and sewer. One lot has been developed in Wellington Estates. No additional subdivisions are anticipated at this time.

Turbotville Borough is projected to meet wastewater collection and treatment needs in the 5-year and 10-year planning horizons. The Turbotville WWTP has enough capacity to meet projected population increase of 30 residents. According to the 2018 Chapter 94 Wasteload Management Report, the Turbotville WWTP is not currently, nor projected to be hydraulically or organically overloaded in the next five years. Based on annual average monthly flows reported over the past five years in the 2018 Chapter 94 Wasteload Management Report, flow into the Turbotville WWTP is about 30 to 40 percent of the WWTP permitted capacity of 0.136 MGD.

Future Growth through Bulk Municipal Interconnection with Lewis Township

A possible bulk municipal interconnect has been identified with Lewis Township. The proposed interconnect has not been approved by PaDEP. Presented below is a discussion of previous planning and agreements regarding proposed Lewis Township interconnects.

Lewis Township shares a common border and surrounds Turbotville Borough. The Borough and Township entered into an Inter-Municipal Agreement in 2011. The Agreement allowed the Township to be a bulk customer for the SR54 corridor (referred to in prior studies as “Area B” and consisting of approximately 18 connections) and the Schell and Koch area (referred to in prior studies as “Area C” and consisting of approximately 32 connections). Both areas are within Lewis Township and Lewis Township is responsible for sewage facilities planning and, if necessary, providing sewer service to these areas. The SR54 area is outlined in Figure 4.

The Borough and Township entered into a Memorandum of Understanding (MOU) on 4/19/18 in which both parties agreed to terminate the 2011 Inter-Municipal Agreement. Lewis Township will serve the Schell and Koch Road area according to the MOU. In August 2018, Lewis Township adopted “Minor Act 537 Plan Update: Schell & Koch Road Special Study.” The recommended alternative is to construct a new sewer collection system to convey sewage of customers in the Schell & Koch study area to the existing Lewis Township WWTP.

PAWC and Lewis Township have negotiated an MOU regarding SR54 customers, which is included in Appendix E. This MOU is subject to PaDEP approval. The framework of the MOU is that Lewis Township would fund, engineer, and construct the proposed infrastructure required to connect SR54 customers to a new sewer collection system and convey the wastewater to a connection point located within Turbotville Borough as determined by PAWC. When Lewis Township proceeds with implementing wastewater service for the SR54 corridor, the bulk municipal interconnect will be metered (assuming a low pressure collection system is installed) and based on PAWC’s wastewater Tariff in effect at the time of implementation.

V. Identify Alternatives to Provide New or Improved Wastewater Disposal Facilities

Ownership Alternative

The Turbotville wastewater collection system and WWTP will require investment to continue to provide safe, reliable, and adequate wastewater conveyance and treatment services for Borough residents. Turbotville Borough has determined that the sale of its wastewater system is in the best long-term interest of its residents. The Borough has reached an agreement with PAWC to purchase the wastewater facilities (June 29, 2018 APA); all of which is pending approval with the PUC under Docket A-2018-3004189. Presently, all wastewater facilities are owned and maintained by the Borough.

Turbotville Borough is exiting the wastewater business primarily for long-term rate stability of its wastewater customers and to obtain the benefits and economies of scale that PAWC provides. In addition, the Borough is seeking to monetize its wastewater system. The Borough evaluated options for establishing the funding, but the options each created a burden on the rate payers.

The Borough determined the most feasible alternative was to sell the wastewater facilities to PAWC.

I&I is an issue that causes high daily flows into the WWTP. High flows due to I&I was a contributing factor for several NPDES permit violations, which are listed in Table 2. The sale of wastewater assets to PAWC presents a collection system alternative that would provide new and improved collection system inspection and accelerated rehabilitation / replacement. The selected alternative of the sale of wastewater assets to PAWC is evaluated in more detail in Section VI(A) below.

WWTP Alternatives

Three alternatives have been identified to address WWTP deficiencies described in Section III(3):

- A. Construct a new Sequencing Batch Reactor (SBR) WWTP
- B. Upgrade and replace components of existing extended aeration activated sludge WWTP
- C. Construct a new extended aeration activated Sludge WWTP

All three alternatives represent a significant investment in the Turbotville WWTP. The main difference is the treatment process, and whether to rehabilitate existing underground steel tanks or replace them with a new WWTP with concrete basins (see Table 3 – Comparison of WWTP Alternatives). The no-action and regionalization alternatives were analyzed in the 2017 Special Study, and will not be reconsidered in this Special Study. Alternative A was chosen in the 2017 Special Study and approved by PaDEP per a June 7, 2017 letter. Alternative A consists of the construction of two (2) SBR tanks for all biological treatment, an influent triplex pump station and grinder, chemical feed systems, a post-equalization basin, two (2) aerobic sludge digesters, an ultraviolet disinfection system, an emergency generator, and an alternate for sludge dewatering and disposal facilities. Alternative B is a variant of alternative A that keeps the existing activated sludge process in lieu of installing SBRs. Alternative C proposes to construct a new WWTP instead of rehabilitating the existing WWTP. Figure 5 shows a potential location of the new Alternative C WWTP within the fenced in area of the existing WWTP parcel; additional locations could be considered within the existing WWTP parcel, such as the open area on the east end of the parcel. Figure 6 shows the Alternative C design concept. Alternatives B and C were not evaluated in the 2017 Special Study.

Table 3 - Comparison of WWTP Alternatives

	Alternative A	Alternative B	Alternative C
Replace bar screen	✓	✓	✓
Replace influent pump station and valve vault	✓	✓	✓
Install new SBR WWTP including two SBR basins, post equalization basin, and two aerobic digesters	✓		
Demolition of abandoned concrete circular tank to accommodate	✓		

	Alternative A	Alternative B	Alternative C
construction of new tankage overtop circular tank			
Rehabilitate existing steel aeration and settling tanks and aerobic digestion tank (may include weir length modification for peak daily flow conditions)		✓	
Replace grates, aeration piping & diffusers, pumps & wastewater piping, related appurtenances		✓	
Install new extended aeration WWTP with concrete basins, including flow equalization basin			✓
New blowers, instrumentation, and controls	✓	✓	✓
Install permanent pump between digester and sludge drying beds	✓	✓	✓
UV Disinfection	✓	✓	✓
Phosphorous removal / alum precipitation system ^a	✓	✓	✓
Emergency generator	✓	✓	✓
Existing control building to remain	✓	✓	✓
Existing sludge drying beds to remain	✓	✓	✓

^a The 2017 Special Study SBR alternative specifies "chemical phosphorous removal"

Bar Screen and Influent Pump Station (Alternatives A, B &C)

The existing bar screen, pump station, and valve vault would be replaced. The submersible pump station would be designed to handle a variety of flow conditions under dry and wet weather conditions. Pump selection would account for one pump being out service for flow reliability.

Sequencing Batch Reactors (Alternative A only)

The sequencing batch reactor is a fill-and-draw activated sludge system for wastewater treatment. Two SBR tanks are alternated such that one is filling with raw wastewater from the headworks while the second one is decanting treated wastewater. A single basin achieves equalization, aeration, mixing, and clarification. The proposed SBR tank approach includes integral aerobic sludge digester tanks and a post equalization basin. Disadvantages include more sophisticated

operation and maintenance, and potential of discharging floating/settled sludge during draw cycle. Advantages are ability to shorten cycles to meet varying flow conditions; operational flexibility to meeting changing influent characteristics and/or effluent parameters. However, the operational flexibility generally requires a reduction in design flow and building the SBRs on the existing WWTP property would require demolition of abandoned concrete circular tank to accommodate new SBR tankage overtop of the circular tank. No geotechnical evaluation has been completed to determine foundation requirements for new concrete SBR tanks.

Rehabilitate Existing Steel Tanks (Alternative B only)

Existing treatment trains consisting of aeration tanks and secondary settling basins would be taken out of service for inspection to determine rehabilitation scope. Depending on the inspection, steel tank rehabilitation may include an engineered coating designed for a corrosive environment seen in a WWTP. In addition, rehabilitation would consist of removing and replacing grates, aerator diffusers, pumps, piping, and appurtenances. The WWTP would remain in service by carefully phasing rehabilitating one treatment train at a time, and hauling sludge offsite during inspection and rehabilitation of the single aerobic digestion tank.

Install New Extended Aeration Activated Sludge WWTP (Alternative C only)

The new WWTP would consist of a precast concrete system with modular multi-tank cells, as illustrated in Figure 6. Rectangular chambers composed of cast in place base, wall panels, and cap walkways provide more durable WWTP components compared to the currently installed steel tanks. Concrete cells would include an equalization tank, two aeration tanks, two clarifier tanks, two sludge holding tanks.

Ultraviolet (UV) Disinfection System (Alternatives A, B & C)

The 2017 Special Study states, "In consideration of the emphasis on safety issues, anti-degradation regulations to protect water resources, and the growing potential that chlorination facilities will be phased out by regulatory action, and alternate means of disinfection is being proposed as a component of the upgrade project. Accordingly, a UV system consisting of three parallel enclosed UV reactors, each with a treatment capacity of 0.136 MGD, will be installed in a dedicated building... Three identical units would provide redundancy for the average monthly flow while also providing up to 0.408 MGD of capacity for peak flow events." Alternative B would follow an arrangement similar to Alternative A with a new UV disinfection system and building. Alternative C would likely consist of a "package" wastewater treatment plant that would include UV disinfection.

VI. Evaluation of Alternatives

Evaluation of Sale of Wastewater Assets

PAWC has superior institutional and financial capabilities, and is well qualified to own, operate, improve and maintain the Turbotville Borough wastewater system in an efficient and effective manner.

Proper management of the sewer facilities is a key element in the long-term performance of the wastewater system. Management includes ownership, operation, maintenance, repairs, replacement, and planned growth of the facilities. The Borough selected PAWC because of its financial stability, and proven experience in the operation and maintenance of wastewater systems.

The transaction will result in public benefits of a substantial nature. Reasons outlined below establish PAWC's commitment and ability to address any currently unmet or future Turbotville Borough wastewater needs.

First, PAWC has extensive experience in the operation of wastewater collection and treatment systems. PAWC, as a large and long-established public utility, has the managerial, technical, and financial fitness to operate the Turbotville Borough wastewater system in a safe and efficient manner in compliance with the Pennsylvania Public Utility Code, the Pennsylvania Clean Streams Law, and all other applicable statutory and regulatory requirements.

Second, Turbotville Borough's current customers will benefit in several ways from becoming PAWC customers. PAWC is a large, financially-sound company that has the capacity to finance necessary capital additions and improvements that will benefit its customers. In addition, given its size, its access to capital, and its recognized strengths in system planning, capital budgeting, and construction management, PAWC is well-positioned to ensure that high quality wastewater service meeting all applicable state and federal regulatory requirements is provided to Turbotville Borough's customers. Additionally, PAWC is subject to the jurisdiction of the Commission and must comply with the Code. The Borough is not regulated by the Commission and does not need to comply with the Code. See Section VII(C) for additional information about PUC rate filings.

Third, Turbotville Borough's current customers will benefit from enhanced and proven customer service that PAWC provides. These customer service enhancements include, but are not limited to, additional bill payment options, extended customer service and call center hours, enhanced customer information and education programs, and access to PAWC's customer assistance program.

Finally, the transaction will benefit PAWC's existing customers and Turbotville Borough's current customers in the long-term by expanding PAWC's customer base. There will be no immediate rate impact on PAWC's existing customers, and it is expected that the transaction will help PAWC maintain reasonable rates for all its customers going forward. Moreover, by adding additional connections to the entire PAWC system, there are more customers to share future infrastructure investment cost, which promotes stable rates across all PAWC systems. Customers who benefit from near-term improvements will one day help pay for improvements on behalf of other customers in other parts of the PAWC system. Being able to spread the costs of investing in and maintaining public wastewater systems over a growing customer base, particularly in a time of increased environmental requirements, is essential to the continued success of wastewater systems and maintaining reasonable rates for customers. Indeed, the Pennsylvania General Assembly recognized, as a matter of public policy, the importance of consolidation and cost sharing in the passage of Act 11 of 2012.

The proposed sale and transfer of the Turbotville Borough wastewater system to PAWC serves the public interest for numerous reasons:

- PAWC is a technically-competent, economically-strong operator with substantial and deep experience in wastewater system operations.
- PAWC's larger base and breadth of operations allow for economies of scale across the spectrum of operations, including purchasing power for commodities, more efficient staffing and shared support, and application of the latest technological capabilities.
- By transferring the wastewater system to PAWC, the system and its customers will become part of an exponentially larger customer base, under regulatory arrangements (including Pennsylvania Act 11) that allow a spreading of system costs across that larger base, thereby reducing potential rate shock and burdens that are inherent in having a small system bear major capital and operating expenses.
- The transfer offers prospects for improved customer service and operations under PAWC ownership of the Turbotville Borough wastewater system.
- PAWC will have better and more varied access to capital to make required expenditures and improvements and comply with applicable legal requirements, such as collection system and pump station improvements.
- The transaction will bring additional expert oversight of the system from the Public Utility Commission and other agencies that routinely monitor utility operations and participate in utility proceedings.
- Some of the anticipated proceeds from the transaction are expected to be used to balance the Borough's annual budget, invest in infrastructure improvements, market the region to new businesses and residents, and improve services to existing businesses and residents.
- As a private entity, PAWC will be a taxpayer that will be paying additional property taxes that will increase revenues to the Borough.

PAWC would follow the processes defined in the Long Term Infrastructure Improvement Plan (LTIIP) for accelerated rehabilitation and replacement of aging wastewater collection systems. The 2014-2019 LTIIP was approved by the PUC in 2014. An updated LTIIP covering years 2019 to 2023 was submitted to the PUC on 11/8/2018 and is pending approval. Using a currently in progress state-wide gravity collection inspection program that will cover all PAWC wastewater systems over the next three years, PAWC plans to inspect the entire Turbotville collection system (including every manhole) using CCTV / multi-sensor robotic inspection. Inspection will involve collection of attribute data for accurate Geographic Information System (GIS) records. The robotic inspection captures GPS data, including the coordinates of every service lateral flowing into the gravity system, which will improve PAWC's ability to respond to PA one-call requests. Inspection results will be used to develop a prioritized list of replacement and rehabilitation projects to help reduce system wide I&I.

Evaluation of WWTP Alternatives

WWTP alternatives are evaluated below following the outline from the General Plan Content Checklist. This completes a consistency evaluation with respect to various environmental regulations and cost effectiveness.

A. Evaluation of WWTP Alternative

1. Clean Streams Law and Clean Water Act

Sections 4 and 5 of the Clean Streams Law require that consideration be given to: water quality management and pollution control in a watershed as a whole. Section 208 of the Clean Water Act calls for the development of plans for the identification of treatment works necessary to meet the anticipated municipal and industrial waste treatment needs. WWTP alternatives identified in this Act 537 Special Study are consistent with the Clean Streams Law and Clean Water Act because they address the ability of Turbotville WWTP to meet NPDES effluent limits.

2. Municipal Wasteload Management Annual Chapter 94 Reports

Data from the Turbotville's recent Chapter 94 Wasteload Management Report (Appendix C) indicate the WWTP is not currently nor projected to be in hydraulic or organic overload conditions. Alternatives A, B, or C would not alter the WWTP hydraulic capacity. Therefore, all three alternatives would be able to treat hydraulic and organic load projections and are consistent with the findings of the most recent Wasteload Management Report.

3. Title II of the Clean Water Act

Title II of the Clean Water Act requires the application of the best practicable waste treatment technology before discharging into receiving waters. WWTP alternatives identified in this study are consistent with this requirement: extended aeration activated sludge as well as sequencing batch reactors are commonplace best practical treatment technologies to meet the requirements of the NPDES permit limits.

4. Comprehensive Plans

All three WWTP alternatives are consistent with the Northumberland County Comprehensive Plan which was adopted by Turbotville Borough in June, 2005.

5. Antidegradation Requirements Contained in Chapters 93, 95, and 102

Proposed wastewater alternatives must be consistent with the water quality criteria of Chapter 93. Chapter 93 designates uses of the water of the Commonwealth which apply to any proposed receiving stream. They must be consistent with the wastewater treatment requirements of Chapter 95. All three WWTP alternatives are consistent with these requirements as the discharge will remain within permit limits.

The chosen alternative must also be consistent with the erosion and sedimentation control regulations contained in Chapter 102. If construction activity would impact an area greater than

5,000 sq. ft, a Soil Erosion and Sediment Control Plan would be prepared. If the area of disturbance is one acre or greater, an NPDES permit for stormwater discharges associated with construction activities would be required. Alternatives A and B, or C will likely not require an NPDES permit for stormwater discharges associated with construction activities because the WWTP area within perimeter fence is approximately 0.87 acres and no earth disturbance is anticipated outside of this area. Should the area of disturbance be greater than 1 acre, an NPDES permit application will be completed.

6. State Water Plans

The State water plan was developed as a comprehensive management tool to guide the conservation, development and administration of the Commonwealth's water and related land resources. The Turbotville wastewater system is located within the West Branch Susquehanna River Watershed Region. No new surface water discharges are proposed under this Special Study. All three alternatives are consistent with the State Water Plan.

7. Pennsylvania Prime Agricultural Land Policy

Pennsylvania's Prime Agricultural Land Policy orders and directs the prevention of the irreversible conversion of prime agricultural land to uses that result in its loss as an environmental or essential food production resource. The Natural Resource Conservation Service inventory must be used to assess where various classifications of land that fall within the Policy are located and where the Policy applies. The WWTP site has been disturbed previously for initial WWTP construction and subsequent upgrades. The alternatives presented in this Special Study will not result in the loss of prime agricultural land and are considered to be consistent with the Pennsylvania's Prime Agricultural Land Policy.

8. County Stormwater Management Plans

The Northumberland County Subdivision and Land Development Ordinance covers Turbotville Borough and addresses stormwater management for new development. The County does not have an approved Act 167 Stormwater Management Plan for the Warrior Run Watershed. Therefore, Alternatives A, B, and C are consistent with County Stormwater Management Plans.

9. Wetland Protection

Exhibit 18 illustrates wetland areas near the Turbotville WWTP, as published by the US Fish and Wildlife Service National Wetlands Inventory. Wetlands near the WWTP include the receiving stream Warrior Run, and the railroad swale located on the north side of the WWTP property. Alternatives A, B and C do not include construction within these defined wetland

areas; therefore, the alternatives in this Special Study are consistent with the regulatory requirement for wetland protection.

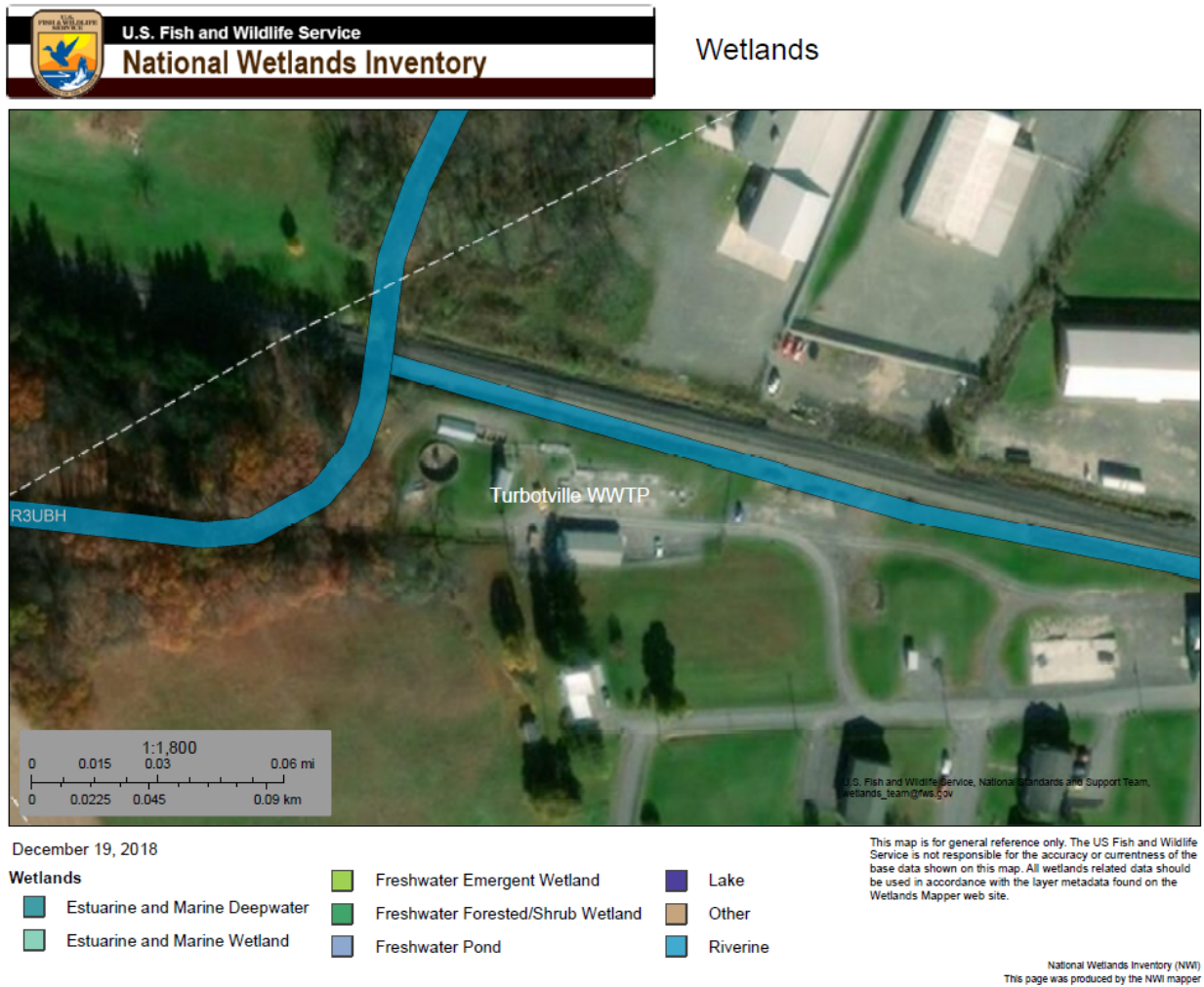

Exhibit 18 - Wetland Areas near the Turbotville WWTP

10. Protection of Rare, Endangered or Threatened Plant and Animal Species

A search of the Pennsylvania Natural Diversity Inventory (PNDI) electronic database was completed for the area around the Turbotville WWTP. The review indicates there are no known impacts to threatened and endangered species and/or special concern species within the project area. A copy of the completed and signed PNDI is included in Appendix F.

11. Historical and Archaeological Resource Protection

As part of the 2017 Special Study by Uni-Tec, a Cultural Resource Notice was submitted to the Pennsylvania Historical and Museum Commission (PHMC), Bureau of Historic Preservation for the WWTP area. A January 24, 2017 review letter was issued by PHMC indicating that the project on the WWTP site will have no effect on historic properties. This letter is still valid and is included in Appendix G.

B. Resolution of Inconsistencies

No inconsistencies were identified in the analysis above.

C. Applicable Water Quality Standards Evaluation

Alternatives A, B and C do not appear to conflict with applicable water quality standards, effluent limitations, or other technical, legislative or legal requirements. Each alternatives' ability to meet NPDES effluent limitations is shown in Table 4.

Table 4 - Comparison of Alternative Ability to Meet Effluent Limitations

Effluent Parameter	Alternative A	Alternative B	Alternative C
pH	The proposed SBR plant would be designed to meet minimum and maximum NPDES pH limits	Data show current WWTP pH is within range of NPDES permit limits. Proposed improvements are not anticipated to alter plant performance for pH	The proposed extended aeration activated sludge plant would be designed to meet minimum and maximum NPDES pH limits
Total Residual Chlorine	Each alternative includes an ultraviolet disinfection system which would replace chlorine tablet feed system. Chlorine tablet system could remain in service as a backup to UV		
CBOD5	The proposed SBR plant would be designed to meet NPDES CBOD5 limits	Rehabilitation of the existing WWTP activated sludge process tanks, overflow weirs, blowers, and diffused air system will be in accordance with the DEP Domestic Wastewater Facilities Manual to ensure adequate removal of CBOD5.	The proposed extended aeration activated sludge plant would be designed to meet NPDES CBOD5 limits

Effluent Parameter	Alternative A	Alternative B	Alternative C
Total Suspended Solids	The proposed SBR plant would be designed to meet NPDES TSS limits	Rehabilitation of the existing WWTP activated sludge process tanks, overflow weirs, blowers, and diffused air system will be in accordance with the PaDEP Domestic Wastewater Facilities Manual to ensure adequate removal of TSS.	The proposed extended aeration activated sludge plant would be designed to meet NPDES CBOD5 limits
Fecal Coliform	Each alternative includes an ultraviolet disinfection system which would be sized for maximum daily flow		
Ammonia-Nitrogen	The proposed SBR plant would be designed to meet NPDES Ammonia-Nitrogen limits	Rehabilitation of the existing WWTP activated sludge process tanks, overflow weirs, blowers, and diffused air system will be in accordance with the PaDEP Domestic Wastewater Facilities Manual to ensure adequate removal of Ammonia-Nitrogen.	The proposed extended aeration activated sludge plant would be designed to meet NPDES Ammonia-Nitrogen limits
Total Phosphorous	The proposed SBR plant would be designed to meet NPDES Total Phosphorous limits	Alternative B includes the permanent installation of a liquid alum phosphorous precipitation system	Alternative C includes the permanent installation of a liquid alum phosphorous precipitation system
Total Copper	The proposed SBR plant would be designed to meet NPDES Total Copper limits	The existing WWTP has met NPDES Total Copper limits.	The proposed extended aeration activated sludge plant would be designed to meet NPDES Total Copper limits

D. Cost Estimate

Preliminary opinion of probable construction and total project costs for each WWTP alternative are presented in Table 5 to Table 7 below. The EPA Wastewater Technology Fact Sheet Sequencing Batch Reactors (September, 1999) states: "Operation and maintenance (O&M)

costs associated with an SBR system may be similar to a conventional activated sludge system.” O&M costs include operator salary and training, maintenance supplies, laboratory testing, electricity, chemical dosing, sludge disposal / solids handling. It is assumed O&M costs will be similar and the lowest cost alternative is determined by total project cost of initial installation. Alternative A is the highest cost option with a preliminary opinion of probablye construction cost of \$3.47 Million and total project cost \$4.51 Million. Alternative B is the lower cost option with a preliminary opinion of probable construction cost of \$2.33 Million and total project cost of \$3.02 Million. Alternative C has similar costs compared to Alternative B, with preliminary opinion of probably construction cost of \$2.51 Million and total project cost of \$3.26 Million. Alternative C is the selected alternative because it is more cost effective compared to Alternative A, and, at a similar cost to Alternative C, will provide a long-term solution to address the WWTP condition.

Table 5 - Preliminary Opinion of Alternative A Probable Construction and Total Project Cost

Item	Description	Quantity	Units	Unit Price ^a	Total
1	General Requirements	1	LS	\$120,000	\$120,000
2	Demolition	1	LS	\$70,000	\$70,000
3	Erosion & Sediment Control	1	LS	\$10,000	\$10,000
4	Triplex Influent Pump Station	1	LS	\$200,000	\$200,000
5	SBR System, incl. Tank and Blowers	1	LS	\$1,575,000	\$1,575,000
6	SBR Control Building	1	LS	\$45,000	\$45,000
7	Mechanical Building	1	LS	\$125,000	\$125,000
8	Ultraviolet Disinfection Building	1	LS	\$65,000	\$65,000
9	UV Units (3 total)	1	LS	\$120,000	\$120,000
10	Sludge Drying Bed Renovations	1	LS	\$35,000	\$35,000
11	Site and Yard Piping	1	LS	\$110,000	\$110,000
12	Electrical incl. Emergency Generator	1	LS	\$300,000	\$300,000
Construction Subtotal					\$2,775,000
25% Contingency ^b					\$693,750
Total Construction Cost					\$3,468,750
Non-Construction Project Cost (30%)					\$1,040,625
Total Project Cost					\$4,509,375

^a Unit prices obtained from 2017 Special Study and rounded to nearest \$5,000

^b Contingency increased to 25% to reflect planning level cost estimate

Table 6 - Preliminary Opinion of Alternative B Probable Construction and Total Project Cost

Item	Description	Quantity	Units	Unit Price ^a	Total
1	General Requirements	1	LS	\$120,000	\$120,000
2	Demolition of Shed and Site Cleanup	1	LS	\$30,000	\$30,000
3	Erosion & Sediment Control	1	LS	\$10,000	\$10,000
4	Triplex Influent Pump Station	1	LS	\$200,000	\$200,000
5	Rehabilitation of Steel Tanks incl. steel grates, aerator diffusers	1	LS	\$750,000	\$750,000
6	New blowers and controls	1	LS	\$150,000	\$150,000
7	Phosphorous Removal System Permanent Installation	1	LS	\$10,000	\$10,000
8	Ultraviolet Disinfection Building	1	LS	\$65,000	\$65,000
9	UV Units (3 total)	1	LS	\$120,000	\$120,000
10	Sludge Drying Bed Renovations	1	LS	\$35,000	\$35,000
11	Site and Yard Piping	1	LS	\$70,000	\$70,000
12	Electrical incl. Emergency Generator	1	LS	\$300,000	\$300,000
Construction Subtotal					\$1,860,000
25% Contingency					\$465,000
Total Construction Cost					\$2,325,000
Non-Construction Project Cost (30%)					\$697,500
Total Project Cost					\$3,022,500

Table 7 - Preliminary Opinion of Alternative C Probable Construction and Total Project Cost

Item	Description	Quantity	Units	Unit Price ^a	Total
1	General Requirements	1	LS	\$120,000	\$120,000
2	Demolition of Shed and Site Cleanup	1	LS	\$30,000	\$30,000
3	Erosion & Sediment Control	1	LS	\$10,000	\$10,000
4	Triplex Influent Pump Station	1	LS	\$200,000	\$200,000
5	Extended Aeration Replacement WWTP with Concrete Basins, including Flow Equalization Basin, and UV Disinfection	1	LS	\$1,200,000	\$1,200,000
6	Phosphorous Removal System Permanent Installation	1	LS	\$10,000	\$10,000
7	Sludge Drying Bed Renovations	1	LS	\$35,000	\$35,000
8	Site and Yard Piping	1	LS	\$100,000	\$100,000
9	Electrical incl. Emergency Generator	1	LS	\$300,000	\$300,000
Construction Subtotal					\$2,005,000
25% Contingency					\$501,250
Total Construction Cost					\$2,506,250
Non-Construction Project Cost (30%)					\$751,875
Total Project Cost					\$3,258,125

E. Proposed Purchase Price and Costs of Implementing Proposed Acquisition

The purchase price for Turbotville Borough wastewater assets is \$365,000. This purchase price is exclusively for the acquisition of the wastewater assets currently in place and owned and operated by Turbotville Borough. The cost of implementing the acquisition has yet to be determined, but would include all legal and associated costs with the PUC filing, title work, and other transaction costs necessary to close the acquisition, which will occur after the PUC has issued its Order approving the application filing (Docket A-2018-3004189).

Estimated cost of operating the Turbotville wastewater system are shown in Section VII (A)(3) below.

After the acquisition, the Turbotville wastewater system will require capital investment to provide safe, reliable, and adequate wastewater conveyance and treatment services for Borough residents. The chosen alternative for the WWTP has an estimated total project cost of \$3.26 Million. Collection system investment is not yet known and will be determined after the entire collection system is evaluated according to the practices outlined in the latest PUC-approved Wastewater Long Term Infrastructure Improvement Plan.

If Turbotville Borough maintains ownership of its wastewater system and moves forward with the alternative from the 2017 Special Study to install a new SBR plant, monthly user rates are estimated to increase from the current rate of \$40 per month to \$64.45 to \$103.93 per month, depending on PENNVEST funding or grant availability (see Table 8 in the 2017 Special Study). The chosen alternative of this Act 537 Special Study is the sale of Turbotville Borough's wastewater assets to PAWC and the subsequent installation of a new extended aeration activated sludge WWTP (Alternative C) would result in Turbotville customers adopting Rate Zone 1 (Section 6.1(j) of the APA). Most customers will be billed based on water usage. According to the current Wastewater Tariff, monthly metered charges under wastewater Rate Zone 1 include a \$10 service charge, a charge of \$1.5132 per 100 gallons, and a negative surcharge of -7.68% which is a decrease that is the result of the Tax Cuts & Jobs Act. A typical residential customer using 3,000 gallons per month would pay \$51.14 per month¹. Wastewater customers who typically use 5,000 gallons per month would pay \$79.08 per month.

F. Analyze the Need for Immediate or Phased Implementation of the Proposed Alternative

All changes related to the proposed sale of the Turbotville Wastewater system to PAWC will be in effect on the date the asset acquisition closes. Design of the chosen WWTP alternative would begin upon PAWC ownership of the Turbotville wastewater system.

¹ $(10 + 3000 * 1.5132 / 100) * (1 - 7.68/100)$

G. Evaluate Administrative Organizations and Legal Authority Necessary for Plan Implementation

PAWC is a public utility regulated by the PUC. PAWC currently provides water and wastewater service to more than 400 communities in Pennsylvania. As a leading wastewater provider in Pennsylvania, PAWC brings industry leading expertise and has extensive technical experience in upgrading, operating and maintaining sewer facilities. PAWC is a recognized leader in providing communities in the Commonwealth with well-maintained and reliable water and wastewater service and has extensive local knowledge due to PAWC's decades of experience providing water service in Milton and surrounding areas.

PAWC has a strong and ongoing commitment to investing in and maintaining infrastructure, and an established track record of successfully managing large capital investment projects in order to continually provide reliable service to the communities it serves. PAWC has an ongoing program of capital investment focused on systematically replacing and adding new pipes, treatment and pumping facilities, and other water and wastewater infrastructure thereby minimizing customer disruption caused by infrastructure failure. PAWC has funded in excess of \$1 billion in capital construction over the past five years with expenditures expected to total \$275 million to \$300 million per year for the next five years. Capital planning is performed by in-house engineering and operations staff to establish capacity needs, regulatory impacts, service adequacy and reliability for PAWC's wastewater systems. Project costs, alternatives and risks are also determined. Comprehensive periodic oversight of water and wastewater assets gives PAWC a clear and objective view of needs and potential capital project solutions.

As found by the PUC in its determination concerning the recently completed transfer of the Scranton wastewater system to PAWC, "PAWC is better positioned to own and operate the combined wastewater system and to implement the necessary capital improvements to the system in conformance [with all applicable regulatory requirements]."² The PUC specifically noted that:

- PAWC is the Commonwealth's largest water and wastewater provider with total assets of \$4.6 billion and annual revenues of \$661 million in 2017, producing operating income of approximately \$346 million and net income of approximately \$161 million.
- PAWC has an established track record with extensive experience in delivering large, complex water and wastewater capital improvement projects.
- PAWC has funded in excess of \$1 billion in capital construction over the past five years.
- PAWC currently operates 18 WWTPs in Pennsylvania, including three biological nutrient removal treatment systems.
- As a subsidiary of American Water Works Company, PAWC has available to it the resources of American Water Works Service Company, Inc., including access to professionals with expertise in various specialized areas.

Because PAWC has access to the equity markets, in addition to its strong balance sheet and credit ratings, it is better positioned than Turbotville Borough to address the myriad of costs and obligations associated with present and future improvements and operation of the Turbotville Wastewater system. PAWC currently has a credit rating by Standard and Poors rating of A.

² PUC Docket No. A-2016-2537209, Opinion and Order (October 19, 2016) at 46.

PAWC has access to a \$400-million line of credit and has access to equity markets that are unavailable to Turbotville Borough. In general, PAWC has a more positive future financial outlook than Turbotville Borough.

In this regard, the contemplated transaction will provide a public benefit to Turbotville Borough system customers because they will join PAWC's large customer base. PAWC provides water service to approximately 658,000 customers and wastewater service to approximately 65,000 customers. The company is the water and/or wastewater provider for more than 400 communities across the Commonwealth, with a combined population of approximately 2.4 million people. Because of its size and expertise in wastewater management and the leveraging of economies of scale, PAWC will be able to improve efficiencies and lower the costs that would otherwise be incurred to operate the Turbotville Borough system and fund necessary improvements to the system. These efficiencies will help keep rates lower for the Turbotville Borough system customers than they would be if not allowed to become part of PAWC's customer base (see Section VI(E) above).

A key consideration, and benefit of the contemplated transaction, arises from the enactment and application of Pennsylvania's Act 11. Act 11 allows investor owned public utilities in setting rates to spread some or all system improvement costs across their broader customer base, rather than allocating all costs and establishing rates system-by-system. PAWC has been a leader in implementing Act 11, and moving toward spreading costs and blending rates across its water and wastewater customers within Pennsylvania as a whole. By spreading improvement costs across PAWC's combined customer base, the costs of improvements imposed on Turbotville Borough customers can be reduced in a manner to avoid what might otherwise be an unreasonable and burdensome rate impact.

VII. Institutional Evaluation

A. Analysis and Description of Institutional Alternatives Necessary to Implement Proposed Alternatives

1. Need for New Municipal Departments or Municipal Authorities

Following the asset acquisition, the Turbotville Borough wastewater system will be owned and operated by PAWC. Turbotville Wastewater Operations will become part of the existing PAWC organizational structure, and no new departments or authorities will be created as part of this asset acquisition.

Following closing of the proposed transaction, PAWC will operate and maintain the Turbotville Borough wastewater system utilizing a licensed operator supervised by existing staff in PAWC's Milton service district. No current Turbotville Borough employees will be a part of the asset acquisition.

Local staff will be managed through PAWC's operations team that reports to the Company's Vice President of Operations. Over time, as system needs and facilities, technologies, and other

circumstances evolve, PAWC will conduct ongoing reviews of staffing levels, personnel qualifications, and training requirements. The local PAWC Operations Office is located at:

Pennsylvania American Water Company
Milton District
105 Sodom Road
Milton, PA 17847-9762

System staff will receive additional support from the PAWC company-wide engineering, operations, human relations, legal and other service teams. Where necessary, operating staff will be supplemented with specialized services provided by both company-level and corporate parent and affiliate personnel, bringing specialized expertise and talents to bear to address particular issues and concerns.

2. Functions of Existing and Proposed Organizations

Upon the acquisition of the Turbotville Borough sewer system, PAWC will obtain the certificated franchise territory to match the existing Act 537 planning area as shown in Figure 1. The existing Turbotville Borough sewer customers will become direct customers of PAWC. As direct customers of PAWC, the wastewater tariff as approved by the PUC will define the rates, rules and regulations governing the furnishing of wastewater collection and disposal service. As a benefit for existing Turbotville residents that fall within the PAWC certificated franchise area that meet the criteria of a Bona Fide Service Applicant, no capacity reservation fee will be charged and PAWC would contribute to the amount allowable by the tariff a contribution in aid of construction for a necessary sewer extension.

After the asset acquisition is completed, PAWC will own and maintain one (1) WWTP, and all collection system sewers including customer service laterals from the sewer to the limits of the rights-of-way or easement as applicable. Laterals beyond that point on private property are the responsibility of the owner for proper operation and maintenance.

Individual grinder pumps are the responsibility of the owner for proper operation and maintenance. As required by PaDEP in the planning process for new developments with grinder pumps, the municipality or Turbotville Borough would have the ultimate responsibility for the individual grinder pump if it presents a public health issue.

PAWC would respond to and investigate any reports of sewer overflows. If the overflow is discovered within the PAWC owned and maintained collection system, PAWC will stabilize the situation, make corrective actions as necessary to eliminate the overflow, and notify PaDEP as required. Blocked laterals within the right-of-way shall also be corrected by PAWC. Blockage on the homeowner's side of the service are the responsibility of the home owner.

3. Cost of Administration and Capability of Authority/Agency to Reaction to Future Needs

Based on the audited 2017 Municipal Annual Audit and Financial Report, Statement of Revenues and Expenditures:

Turbotville Borough Revenues:

Taxes	\$ 147,712
Licenses & Permits	\$ 125
Fines and Forfeits	\$ 1,041
Interest, Rents, and Loyalties	\$ 1,445
Intergovernmental Revenues	\$ 160,373
Charges for Service	\$ 187,539
Unclassified Operating Revenues	\$ 3,025
Other Financing Sources	\$ 8,739
Total Revenues	\$ 509,999

Turbotville Borough Expenditures:

General Government	\$ 48,510
Public Safety	\$ 19,057
Public Works – Sanitation	\$ 175,117
Public Works – Highways & Streets	\$ 108,525
Public Works – Other Services	\$ 151,815
Culture and Recreation	\$ 3,412
Community Development	\$ 100
Employer Paid Benefits & Withholding Items	\$ 13,287
Insurance	\$ 7,408
Other Financing Uses	\$ 7,200
Total Expenditures	\$ 534,431

PAWC's audited income statement for the 12 months ended December 31, 2017; which was outlined in PAWC's Application filing with the PUC is as follows:

Operating Revenues	\$ 661,088,000
Operating Expenses:	
Operation and Maintenance	\$ 195,123,000
Depreciation and Amortization	\$ 114,843,000
General taxes and other	\$ 5,093,000
Total Operating Expenses	\$ 315,059,000
Operating Income	\$ 346,029,000
Other Income/(Expense):	
Interest & Other Expense, net	\$ (630,000)
Interest Expense, net	\$ (71,254,000)
Total Other Expenses	\$ (71,884,000)
Income Before Income Taxes	\$ 274,145,000
Provision for Income Taxes	\$ 113,441,000
Net income	\$ 160,704,000

PAWC anticipates that the operations expenses will be similar to that of Turbotville Borough during its first year of operation. Turbotville Borough will address its debt prior to closing. PAWC will not be assuming any of Turbotville Borough's debt.

B. Description of Administrative and Legal Activities

1. Incorporation of Authorities or Agencies

As owner and operator of the wastewater system, PAWC will be responsible for the operation, maintenance, repair, replacement, and monitoring of all elements of the wastewater system within the former Turbotville Borough direct service territory, from the laterals at the point of the road right-of-way through the collection system piping.

2. Ordinances, Regulations, Standards, Agreements, Inter-Municipal Agreements

The Asset Purchase Agreement between PAWC and Turbotville Borough states, "Prior to the execution of this Agreement, the Borough shall pass the necessary Resolution(s) adopting PAWC's Rate Zone 1 base wastewater rates, such that those rates would become effective at the time of Closing."

Turbotville Borough current rate, adopted on February 5th, 2018 (Ordinance 1-18), is \$522.00 per year or \$87.00 every two months regardless of the customer class, and exclude fees for tap in, connection & inspection, or capacity reservation. After the asset acquisition, PAWC will implement standard billing practice based on water usage per the latest Tariff. Current rates are the same for all customers and are not dependent on water usage. After the asset acquisition, sewer rates will be calculated based on water usage. Customers not connected to public water will be billed a flat rate per month, per EDU as specified in the Tariff.

Turbotville Borough has existing sewer ordinances that will remain in effect after the asset acquisition. Applicable ordinances include: 88-05 – Mandatory Connection, 88-06 – Rules and Regs, 97-05 – Construction Specs Addressing I&I.

Borough supervisors are committed to the enforcement of all ordinances, codes and policies of the Borough regarding planning, evaluation, design, construction, monitoring and maintenance of the wastewater facilities.

Turbotville Borough will maintain authority to enforce plumbing code and on-lot residential and commercial ordinances, in cooperation with PAWC, including grease trap, sump pump and lateral inspection.

Turbotville Borough is expected to update/amend, maintain and enforce ordinances (1) prohibiting or regulating the discharge into the sewage system of fats, oils, grease, acids and other prohibited substances consistent with the regulations governing the wastewater system (which are consolidated into the PAWC IPP Regulations required by PaDEP); and (2) prohibiting the

discharge into any sanitary sewer of surface or groundwater. PAWC will work with Turbotville Borough if the ordinances need updating.

Turbotville Borough will remain responsible for sewage facilities planning in accordance with Act 537. PAWC will be responsible for the ownership, operation, maintenance, upgrade, expansion, permitting and compliance.

PAWC will be responsible for preparing and submitting annual Chapter 94 Reports as well as other wastewater system permits and notifications, including industrial discharge permitting and sanitary sewer overflow notifications. PAWC will also be responsible for review and approval of planning modules for new connections with respect to the available collection, conveyance and treatment capacity. Related to Chapter 94 Reporting, PAWC will include information required under §94.12 for Turbotville Borough and, at a later time should bulk municipal connections be added to the Turbotville Borough system, include information required under §94.12(b) from Inter-Municipal Agreement Municipalities.

Complaints regarding the public sewer system will be directed to PAWC with the ability to contact the Borough if issues are not adequately handled to obtain assistance in resolving problems. Private sewer systems and on-lot systems will be the responsibility of the property owner.

After the asset acquisition, agreements and inter-municipal agreements can be negotiated by PAWC with other sewer authorities or municipalities. If new development or redevelopment is proposed, PAWC will cooperate with Turbotville Borough in the review and approval of sewage facility planning modules for such projects. PAWC will accept, convey and treat all domestic sewage flows from such development/redevelopment projects within the certificated franchise area and consistent with the Tariff. PAWC will accept, convey and treat new or increased industrial wastewaters of quantities and physical/chemical characteristics consistent with PAWC's IPP regulations, all applicable federal and state regulations and NPDES permit requirements, and the hydraulic and treatment capacity of the Turbotville WWTP.

Turbotville Borough shall be the responsible party for its municipal separate storm sewer system (MS4) unless the Borough has prior to the date of this plan sold said system in which case the buyer shall be the responsible party. If any existing combined sewer systems, which none are known of, are separated into separate sanitary only systems and MS4 stormwater systems, the facilities and assets relating to the MS4 systems will be conveyed to and become the responsibility of the involved municipality or responsible party.

3. Transfer of Rights-of-Way, Easements, and Land Transfers

Pursuant to the Asset Purchase Agreement, Turbotville Borough will convey to PAWC all of Turbotville Borough's rights to all real and personal property comprising the wastewater system, including all property owned in fee, all easements, and all rights-of-way for the wastewater system's collection, pumping, and discharge facilities. As a PUC-regulated public utility, PAWC has the right to obtain rights-of-way within municipal streets and highways for underground water and wastewater lines, and PAWC anticipates cooperating with the involved municipalities in the siting and installation of such facilities. Where the acquisition of easements or other rights to private property are necessary, PAWC endeavors to negotiate an amicable purchase of such

rights on mutually acceptable terms where feasible. Where necessary, as a PUC-regulated facility, PAWC may exercise the power of eminent domain to acquire easements or property under the provisions of the Eminent Domain Code.³

4. Adoption of Other Municipal Sewage Facilities Plans

Turbotville Borough would be responsible for any required adoption of other municipal sewage facilities plans that impact the sewage disposal needs of Turbotville Borough. PAWC, as owner and operator of the Turbotville Borough wastewater system, would provide stakeholder input and be involved in the planning process of other municipal sewage facility plans that may affect the Turbotville Borough wastewater system.

5. Other Legal Documents

Not Applicable

6. Dates or Timeframes for Items 1 to 5 Above

Items 1 to 5 above would be in effect at the date of the closing.

C. Justification for Choosing Specific Institutional Alternative

PAWC is the Commonwealth's largest investor-owned provider of water and wastewater services. As a leading wastewater provider in Pennsylvania, PAWC brings industry leading expertise and has extensive technical experience in upgrading, operating and maintaining sewer facilities. PAWC is a recognized leader in providing communities in the Commonwealth with well-maintained and reliable water and wastewater service and has extensive local knowledge due to our providing water and wastewater service to McEwensville Borough and decades of experience providing water service to other nearby areas in Northumberland County, including the Boroughs of Milton, Northumberland and Watsontown, and portions of the Townships of Delaware, East Chillesquaque, West Chillesquaque, Point, Turbot, and Upper Augusta.

PAWC currently operates 18 wastewater WWTPs that serve approximately 65,000 customers, including residential, commercial and industrial users in 12 counties across the Commonwealth. Treatment processes include state-of-the-art biological nutrient removal systems, sequential

³ 15 Pa.C.S. §1511(e) (grants "public utility corporations" the right to enter public road rights-of-ways to construct and maintain their facilities, without requiring exercise of condemnation authority or payment of consideration to the municipality); see also, 11 Pa.C.S. §12445 (use of Third Class City street right-of-way); 53 P.S. § 67322 (utility facilities in Second Class Township road right-of-way); 53 P.S. §57084 (utility facilities on First Class Township road right-of-way); 36 P.S. §670-411, 67 Pa. Code §459.3(a) (utility facilities in State highway right-of-way). 15 Pa. C.S. §1511; 26 Pa.C.S. §§ 101 et seq.

batch reactors, and oxidation ditches. Given PAWC's existing platform in relation to operation of water and wastewater systems in the region, PAWC is best positioned to provide wastewater service to Turbotville Borough on a cost-effective basis.

PAWC currently employs approximately 1,000 professionals with expertise in all areas of water and wastewater utility operations including engineering, regulatory compliance, water and WWTP operation and maintenance, distribution and collection system operation and maintenance, material management, risk management, human resources, legal, accounting, and customer service.

PAWC is a subsidiary of American Water Works Company, Inc. (American Water) which is the largest publicly traded water and wastewater utility in the United States and provides approximately 15 million people with drinking water, wastewater, and other water related services in over 30 states and 2 Canadian provinces through its regulated subsidiaries, market-based operations, and other services to public and private sector clients. American Water currently owns or operates approximately 200 wastewater operations through its subsidiaries in a number of states.

As a subsidiary of American Water, PAWC has available to it additional resources of highly trained professionals who have expertise in various specialized areas. American Water currently owns or operates approximately 200 wastewater operations through its subsidiaries in a number of states. A 50-person team of American Water corporate engineers has handled a wide variety of system evaluations, selecting treatment processes and establishing critical design criteria for water and wastewater treatment systems in order to improve operations and prioritize capital improvements. American Water's Technology & Innovation (T&I) group is staffed by more than 20 people including chemists, engineers, scientists and microbiologists. The mission of the I&ES Group is to provide value-added technical and environmental resources integral to achieving business objectives through water industry leadership, technical guidance, knowledge sharing, and innovative solutions. American Water's research team, established more than 30 years ago, has been awarded nearly 80 competitive research grants and granted five U.S. patents with several more pending.

The relationship with American Water provides PAWC a broad range of trained professionals with both engineering and operational experience, as well as deep financial resources, to address the environmental compliance challenges of the Turbotville Borough system. American Water's experience includes the full breadth of treatment processes, from facultative ponds to membrane biological reactors in every climate zone across the U.S. More advanced technologies allow a number of American Water's plants to utilize effluent for reuse applications, eliminating discharge to receiving streams. These diverse facilities have provided American Water operators and process experts with deep experience in the operation and maintenance of every possible type of wastewater treatment technology, as well as the experience available to support PAWC's operations staff and facilities. PAWC has specific experience in the types of treatment technologies employed in the Turbotville WWTP, involving numerous activated sludge process plants as well as an extended air activated sludge process in Fairview Township similar in nature to the Turbotville WWTP.

PAWC is well positioned to address the projected operating and capital expense requirements for the Turbotville Borough sewer system area. PAWC is the Commonwealth's largest water and wastewater provider, with total assets of \$4.6 billion and annual revenues of \$661 million for 2017. For 2017, PAWC had operating income of approximately \$346 million and net income of

approximately \$161 million. These operating results produced cash flows from operations of approximately \$337 million.

In addition to generating positive operating cash flows, PAWC may also obtain financing as follows:

Line of Credit - PAWC presently has liquidity through a \$400 million line of credit through American Water Capital Corp. (AWCC), a wholly owned subsidiary of American Water. PAWC's strong credit ratings allow PAWC to obtain additional capacity on this line of credit.

Long Term Debt Financing - PAWC carries a corporate credit rating of "A3" from Moody's Investors Services and an "A" rating from Standard and Poor's Rating Services. PAWC obtains long-term debt financing through AWCC at favorable interest rates and payment terms. When applicable, PAWC also uses low-cost financing through the Pennsylvania Infrastructure Investment Authority (PENNVEST) and the Pennsylvania Economic Development Financing Authority (PEDFA).

Equity Investments - PAWC may obtain additional equity investments through American Water based on its strong operating performance.

Additional information about reasons for public benefits provided by the proposed Turbotville wastewater system transfer to PAWC is provided in Section VI(A).

As a PUC-regulated public utility, the rates charged by PAWC for water and wastewater services are regulated by the PUC through a process which provides clear and robust opportunities for involvement and participation by affected communities and consumers.

The PUC is composed of five commissioners, appointed by the Governor with the advice and consent of the Pennsylvania Senate. The commissioners serve terms of five years. The PUC is an independent commission, meaning that it is not under the direction of the Governor or any other political entity. It is charged with making regulatory decisions, including decisions relating to rates, based on the evidence and applicable law.

In order to provide economical and efficient service to a community, the state grants to water and wastewater companies the right to provide service within a specified geographic area, subject to regulation by the PUC of both the quality and terms of service and the rates charged for those services. The ratemaking and approval process involves multiple steps, and is subject to articulated criteria for assuring fair and reasonable rates.

The Rate Filing: When a regulated utility such as PAWC seeks an increase or change in its base rates, it must file a request with the PUC that shows the proposed new rates and effective date, and must prove that the increase is needed. The utility also must notify customers at least 60 days in advance. The notice must include the amount of the proposed rate increase, the proposed effective date, and how much more the consumer can expect to pay.

PAWC seeks rate increases only when warranted. Because rate proceedings are time-consuming and complex, as a general matter, PAWC typically files rate proceedings on a 3 to 4 year cycle. As noted below, in these periodic rate proceedings, PAWC has been seeking to utilize the authorities provided under Pennsylvania's Act 11 to more broadly spread costs over its larger customer base in order to moderate cost increases and mitigate to the extent possible major

increases impacting localized systems, where major capital improvements are required to meet environmental or other regulatory mandates.

How the PUC Sets Rates: The PUC ratemaking process ensures the lowest reasonable rate for consumers while maintaining the financial stability of utilities. Under the Public Utility Code, a utility is entitled to recovery of its reasonably incurred expenses and a fair return on its investment. The PUC evaluates each utility's request for a rate increase based on those criteria.

In a rate proceeding, PAWC is required to provide detailed information concerning its historic and projected costs of operation (including predictive and preventive maintenance, repair and replacement) and its historic and projected program of capital improvements across all elements of its water and wastewater systems. Annualized costs are typically projected to a future "test" year, which is usually one year following the rate proceeding. The process of determining those costs, and allocating such costs among different classes of consumers (e.g., residential, commercial and industrial customers) involves a series of evaluations and cost-of-service studies. Only those costs determined to be "reasonable and prudent" may be recovered, and in rate proceedings, the PUC will examine whether costs claimed are appropriately justified and reasonable.

The PUC Review Process: The PUC rate review process is far more detailed and arduous than that followed by municipalities and municipal authorities.

By operation of law, the rate request is suspended for up to seven months if the PUC does not act before the proposed effective date for the rate increase for water and wastewater companies. The PUC uses that time to investigate and determine what, if any, of the requested increase is justified.

The PUC's Bureau of Investigation and Enforcement (I&E) and public advocates, including the state's Office of Consumer Advocate (OCA) and Office of Small Business Advocate (OSBA), intervene and participate in that process. I&E reviews the company's records and their request and presents its view on what is in the public interest. Individual consumers may become formal parties by filling out a formal complaint form. OCA and OSBA represent consumers and small businesses respectively, and likewise examine in detail the background and materials submitted by the utility. Prior to hearings on the proposed rates, I&E, OCA, OSBA and others submit information requests to the utility and obtain responses to better understand and investigate the facts behind the proposed rates.

When the PUC investigates a rate increase, it is assigned to an Administrative Law Judge (ALJ), who is an attorney with experience in administrative law. The ALJ presides at formal hearings, which are open to the public and conducted like a formal court proceeding. At the formal hearing, the utility, I&E, OCA, OSBA and other parties present their cases and are subject to cross-examination. Consumers may speak for themselves, or an attorney may represent individual consumers or groups of consumers. Consumers also can have their say informally by writing or calling the PUC or completing the objection/ comment form. Consumers also may testify at public input hearings.

By providing testimony, consumers place their views in the official record on the case. Public input hearings are conducted by the ALJ in the utility's service territory. Consumer testimony becomes part of the record on which the PUC will base its decision.

Following the conclusion of hearings before the ALJ, the entire record of testimony, documents and other evidence is compiled. Proposed findings of fact and briefs may be submitted by the formal parties. After weighing the evidence and hearing the arguments, the ALJ writes a recommended decision addressing each issue in the case within the limits set by law. The recommended decision may approve, disapprove or modify the original request.

The ALJ's report and recommended decision are presented to the PUC Commissioners. Parties to the rate case may file exceptions to the ALJ's report, and responses to objections presented by other parties.

Finally, the matter is brought before the PUC Commissioners for a vote and final decision. The Commissioners make the final decision, authorizing rates that: (1) permit revenues that allow the company to meet its reasonable expenses, pay interest on its debt and provide a fair return to stockholders so it will continue to attract investment; and (2) assign the proper rate for residential, commercial and industrial customers that reflects the cost of service. Together with the 60-day notice period, the PUC's administrative rate review and hearing process takes about nine months.

Decisions made by the PUC may be appealable. Aggrieved parties may seek review of the PUC's determinations through an appeal to the Commonwealth Court. The Commonwealth Court's decisions, in turn, may be subject to review by the Supreme Court of Pennsylvania if that court grants a petition to allow appeal.

Collection System Improvement Charge Process: The paragraphs above describe the process for a base rate proceeding, which sets the basic water and wastewater rates for PAWC's systems. In the period between periodic base rate cases, the Public Utility Code allows for wastewater companies to calculate and assess a Collection System Improvement Charge (CISC), which allows a limited surcharge on customer bills to accelerate the replacement of existing aging facilities that might otherwise be deferred until completion of a base rate case. Eligible projects involve principally replacement investments, not system expansions or extensions of facilities to serve new customers. System improvement charges are designed to provide ratepayers with improved service quality; greater rate stability; fewer sewer breaks; fewer service interruptions; and increased safety. The maximum amount of a CISC is a cumulative 5% above base rates. The CISC process involves an annual review by the PUC and reconciliation of recoverable costs and revenues associated with the charge, and an annual reconciliation hearing under Section 1307(e) of the Public Utility Code. The PUC conducts audits to assure that funds generated from a CISC surcharge are spent on CISC-eligible projects.

VIII. Implementation Schedule and Justification for Selected Alternatives

A. Identify Technical Wastewater Disposal Alternative

The selected alternative involves a sale of the Turbotville Borough wastewater system to PAWC, with PAWC becoming the owner and operator of all wastewater system assets within the direct service territory. Responsibilities for implementation of elements of the Act 537 Plan would be assigned as described above. Alternative C is the selected WWTP alternative.

Section 6.1(f) of the Asset Purchase Agreement between PAWC and Turbotville Borough states, "The approval of any revisions to the Act 537 Plan, as applicable, shall be obtained prior to Closing. PAWC shall be responsible for the preparation, cost and submission of any necessary

revisions to the Seller's Act 537 Plan, but the Seller is only responsible for adopting the amended Act 537 Plan and cooperating with PAWC with the DEP submission and approval process. Should the DEP impose or require any changes to the amended Act 537 Plan submitted by PAWC, or if DEP rejects any revisions to the Act 537 Plan proposed and submitted by PAWC, PAWC shall have the right, in its sole and absolute discretion, to terminate this Agreement."

The selected alternative is the best alternative based on the following considerations:

1. Existing Wastewater Disposal Needs

The selected alternative assures that existing wastewater needs will be managed by a well-experienced, technically-competent, economically-sound public utility company with deeper resources, broader experience, and stronger access to capital than Turbotville Borough. PAWC has a strong record of managing water and wastewater systems, for marshalling resources, planning and constructing capital projects, and managing systems on a sustainable basis using modern preventive and predictive maintenance methods and leading edge system management technologies. The depth of resources brought by PAWC and its parent and affiliated companies, which supplement a sound staffing plan for the local system, assure proper long-term capability of meeting existing wastewater needs.

2. Future Wastewater Disposal Needs

Likewise, the selected alternative provides a means of meeting future wastewater disposal needs. System acquisition by PAWC, which opens the door to broader access to capital together with the potential for spreading costs over a broader customer base via Act 11 promises improved capabilities to meet these current and future wastewater needs.

3. Operation and Maintenance Considerations

The selected alternative provides a foundation to sustain over the long-term and improve operational and maintenance practices. PAWC's sophisticated computerized preventive and predictive maintenance programs, coupled with the engineering and operational experience bench strength of PAWC engineering and operations management and staff, will bring more modern methods, practices and technologies to the Turbotville Borough wastewater system. PAWC's platform offer the capability of supporting the system with shared services and expert staff, providing more cost-effective and efficient staffing. PAWC's purchasing practices for key inputs, such as chemicals and commodities, offer the market volume purchasing and negotiating advantages.

4. Available Management and Administrative Systems

PAWC has been a leader in water and wastewater system sustainable management. Under the selected alternative, PAWC brings state-of-the-art predictive/preventive maintenance programs, system automation and monitoring systems, a well-experienced engineering and operations management team, and well-developed programs for capital investment and system improvement.

5. Environmental Soundness and Compliance with Natural Resources Planning and Preservation Programs

Under the selected alternative, the Turbotville wastewater system will be operated in a manner that best assures compliance with applicable environmental regulations, including the Pennsylvania Clean Streams Law and Clean Water Act. The basic wastewater system will remain as currently contemplated by the Act 537 Plan (and hence no significant changes are anticipated in relation to the system's consistency with natural resource planning or preservation programs). In short, PAWC is bringing to the Turbotville wastewater system the expertise and resources necessary to address any water quality and environmental problems.

B. Designate and Describe Implementation Schedule

Activity	Target Date
Submission of Draft Act 537 Plan Special Study to PaDEP	11/9/18
Meet with PaDEP	11/21/18
Update special study to PaDEP Guidance	11/21/18 to 1/15/19
Prepare draft resolutions and public notice	11/21/18 to 1/15/19
Submit special Study to Turbotville Borough	1/25/2019
Submit special study to Northumberland County Health Department and Planning Commission	1/25/2019
Attend and explain special study to Turbotville Borough Council meeting	February, 2019
Advertise public notice in newspaper	3/1/19
Turbotville Borough planning commission meeting	February - March, 2019
Turbotville Borough Resolution Adoption	March, 2019
Formal submission to PaDEP	April, 2019
PaDEP Approval of Act 537 Plan Special Study	June, 2019
WWTP Design / Permitting	Remainder of 2019 to 2020
Completion of Construction of Selected WWTP Alternative	2021 to 2022

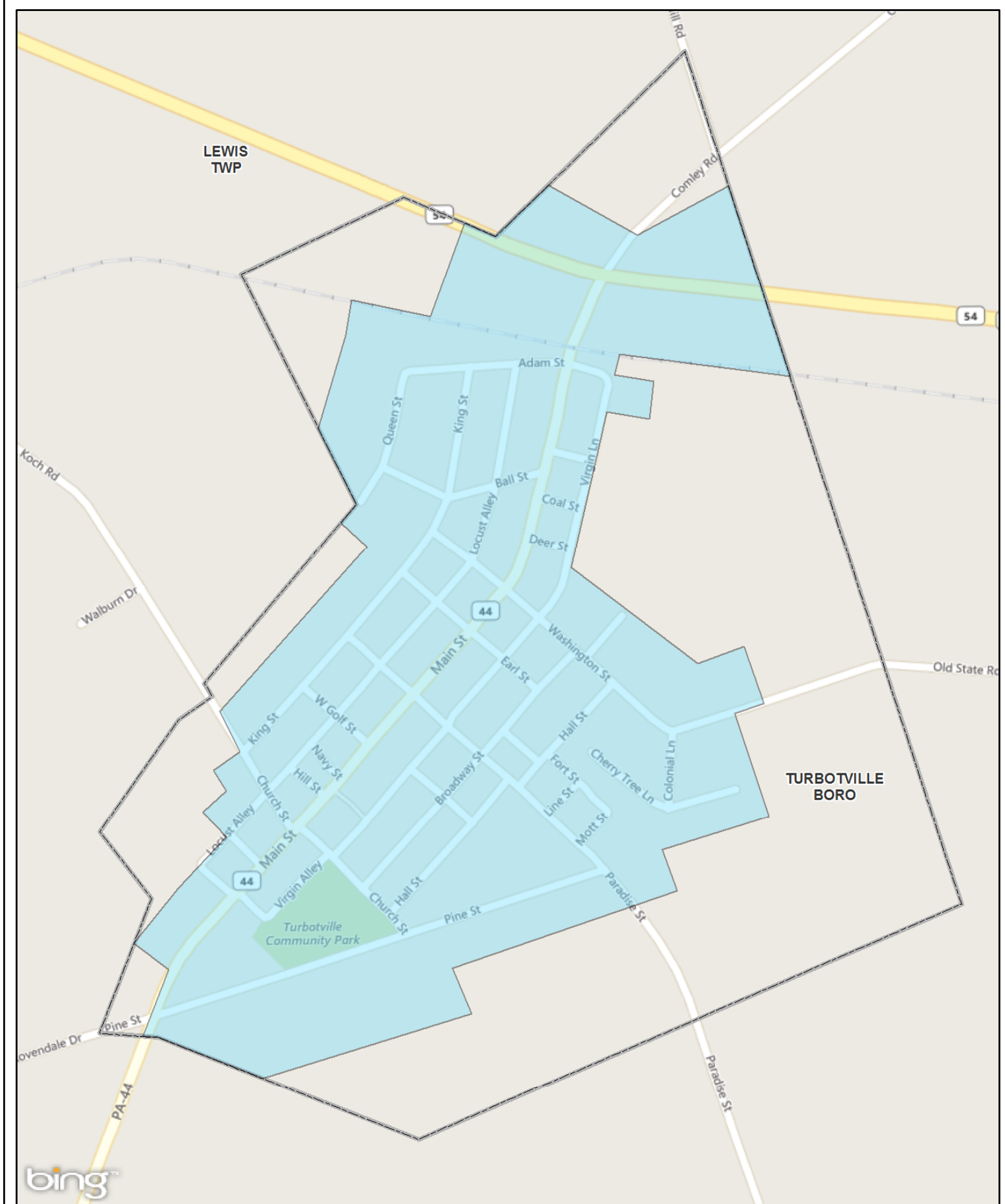

LEWIS
TWP

TURBOTVILLE
BORO

Turbotville
Community Park



Coordinate System: NAD 1983 StatePlane Pennsylvania South FIPS 3702 Feet Projection: Lambert Conformal Conic

Date: 11/28/2018



1 inch = 600 feet

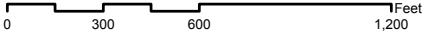

Legend

- Proposed PAWC Certified Franchise Territory & Act 537 Planning Area
- Municipality

TO BE USED FOR REFERENCE ONLY
 Although every effort has been made to ensure the accuracy of the information, errors and conditions originating from physical sources to develop the information may be reflected in the data supplied.

Document Path: \\amwater-net\gwg\userdata\PennsylvaniaAcquisition\Northumberland County\Turbotville\Act 537 Plan\Figure1_Act537_PlanningArea.mxd

**Figure 1 - Planning Area
Turbotville Wastewater System
Northumberland County, Pennsylvania**

Drawn By: cookmm Checked By: gladisb

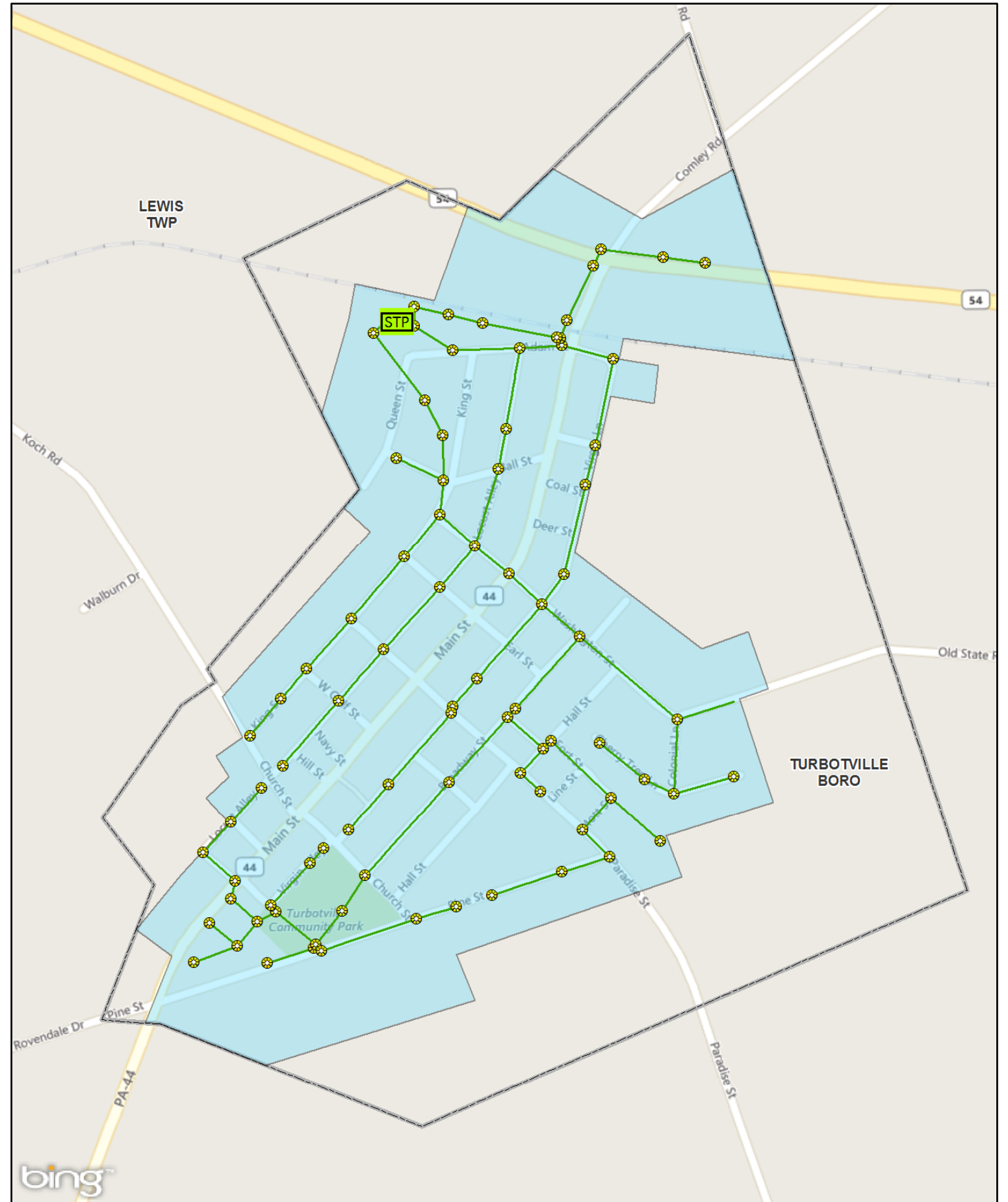

Coordinate System: NAD 1983 StatePlane Pennsylvania South FIPS 3702 Feet Projection: Lambert Conformal Conic

Date: 9/16/2018

Legend

- Manhole
- Treatment Plant
- Gravity Main
- Applied For Wastewater Service Territory
- Municipality

AMERICAN WATER

TO BE USED FOR REFERENCE ONLY
Although every effort has been made to ensure the accuracy of the information, errors and conditions originating from physical sources to develop the information may be reflected in the data supplied.

Document Path: \\hammer-net\proj\userdata\Pennsylvania\Acquisition\Northumberland County\Turbotville\A01-037 Plan\Collection_System_Padlock.mxd

1 inch = 600 feet

0 300 600 1,200 Feet

**Figure 2 - Collection System & Facilities
Turbotville Wastewater System
Northumberland County, Pennsylvania**

Drawn By: cookmm Checked By: gladisb

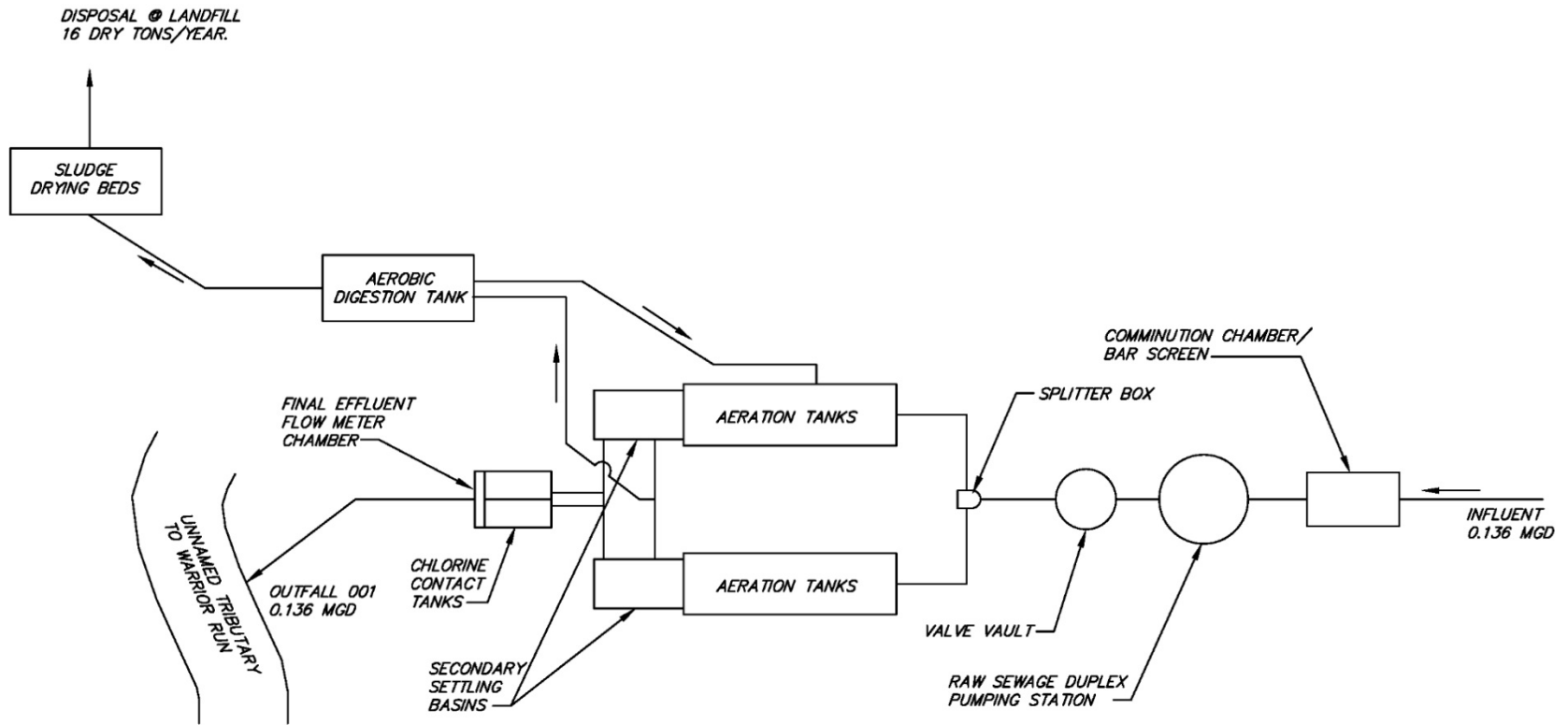
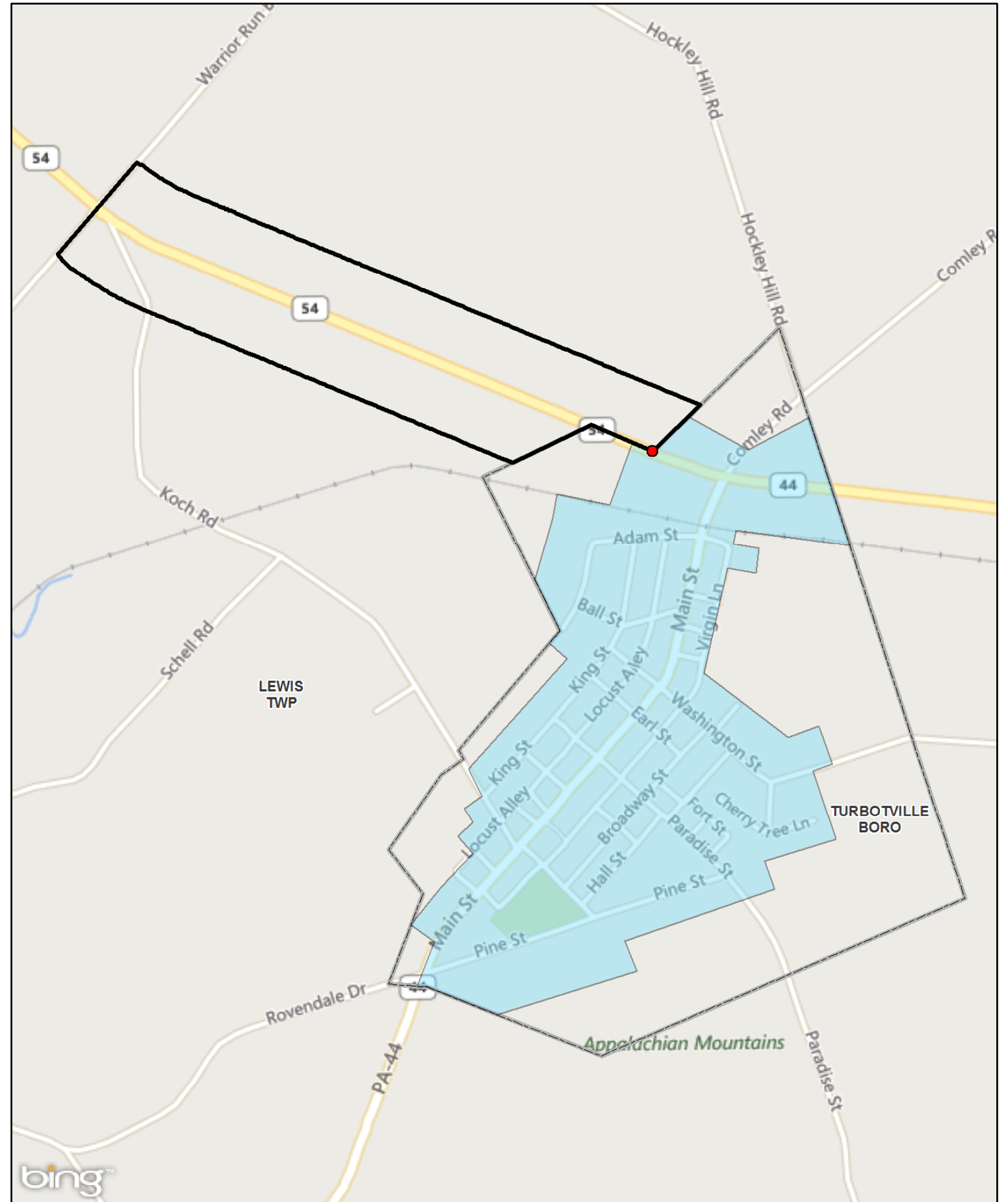

Figure 3 – Turbotville WWTP Schematic



Coordinate System: NAD 1983 StatePlane Pennsylvania South FIPS 3702 Feet Projection: Lambert Conformal Conic

Date: 11/8/2018

Legend

- Connection Point
- Approx. Location of Lewis Township SR 54 Customers (Area B)
- Applied for Wastewater Service Territory
- Municipality

1 inch = 900 feet

0 450 900 1,800 Feet

TO BE USED FOR REFERENCE ONLY
Although every effort has been made to ensure the accuracy of the information, errors and conditions originating from physical sources to develop the information may be reflected in the data supplied.

**Figure 4 - Lewis Township SR 54 Area
Turbotville Wastewater System
Northumberland County, Pennsylvania**

Figure 6 - Alternative C Design Concept

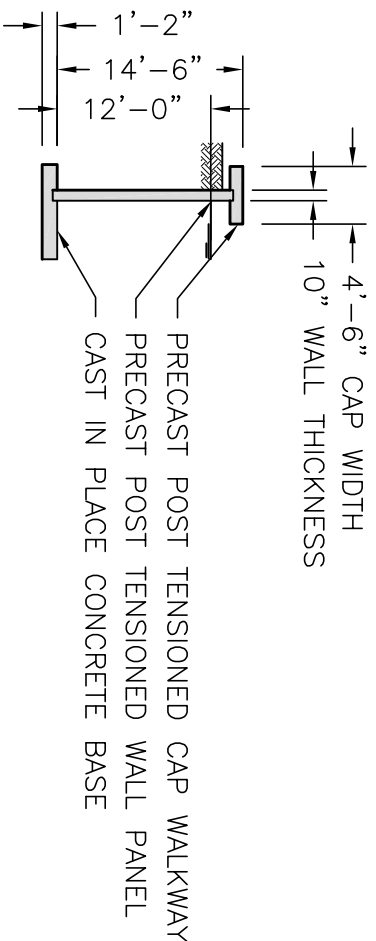
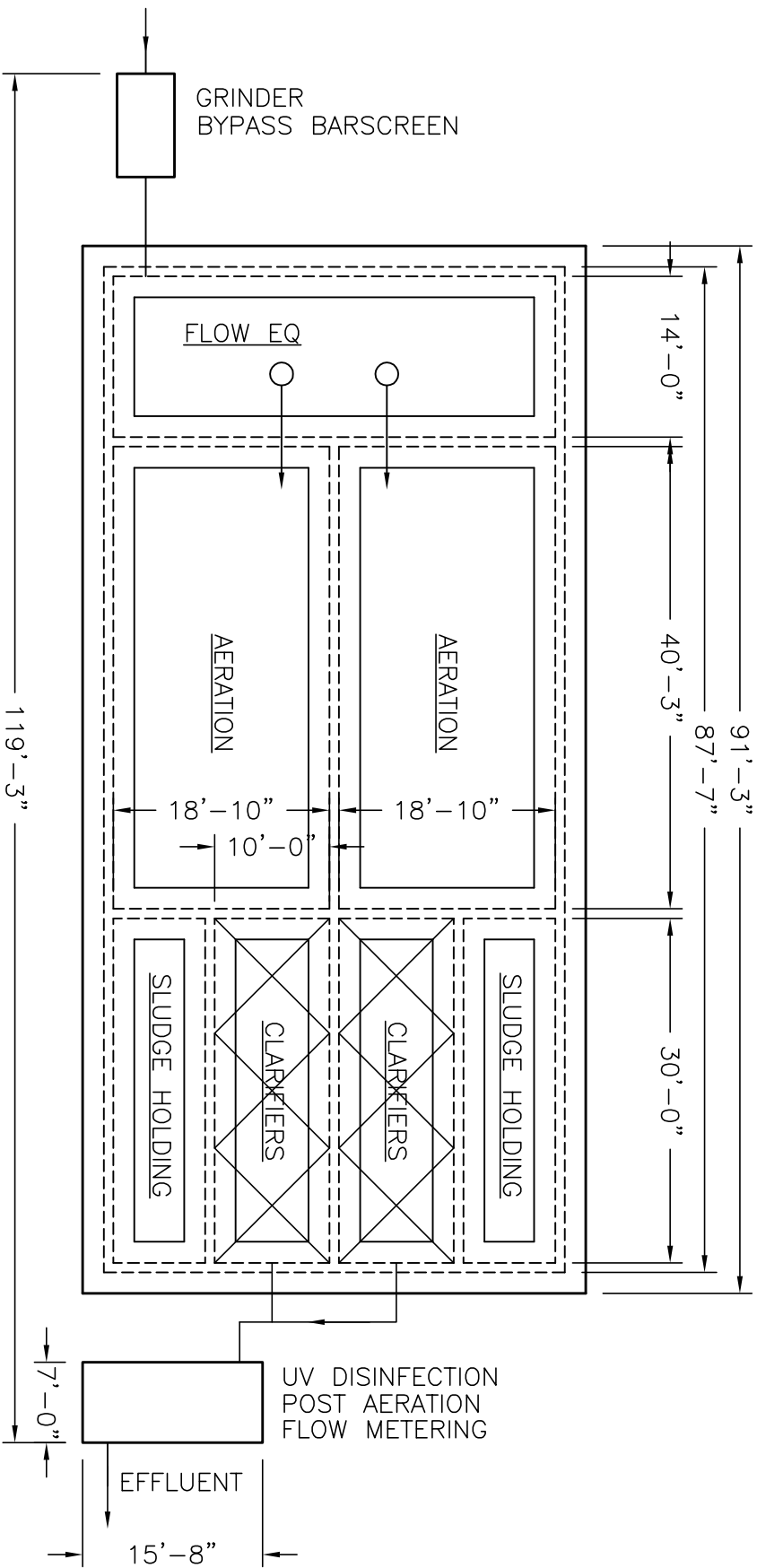

0.136 MGD WWTP PRELIMINARY LAYOUT

DRAWN BY: ADM		SCALE: NTS		DRAWING NO.: 0.136 MGD	
DATE: 1/10/19		REV:			

MACK INDUSTRIES, INC.
 201 COLUMBIA ROAD, VALLEY CITY, OHIO 44280
 (330) 483-3111

Appendix

Appendix

Appendix A

2017 Act 537 Special Study Wastewater Treatment Plant

Act 537 Special Study

Wastewater Treatment Plant

Borough of Turbotville

Northumberland County, Pennsylvania

April 2017

Prepared for:

**Borough of Turbotville
P.O. Box 264
Turbotville, PA 17772**

Prepared by:

**Uni-Tec Consulting Engineers, Inc.
2007 Cato Avenue
State College, PA 16801**

File No. 0047-043-001

TABLE OF CONTENTS

Plan Summary	1
Plan Content	4
I. Previous Wastewater Planning	5
A. Past Wastewater Planning Impact on Current Planning Effort.....	5
1. Previous Act 537 Plan	5
2. Unaddressed Planning in Approved Plan Implementation Schedule.....	6
3. Anticipated or Proposed Planning by Sewer Authority or Approved Under Chapter 94 Corrective Action Plan	6
4. Planning Modules for New Land Development, Planning “Exemptions,” and Addenda	6
II. Physical and Demographic Analysis of Planning Area	6
A. Planning Area and Wastewater Service Area.....	6
B. Physical Characteristics	6
C. Soils.....	6
D. Geologic Features.....	7
E. Topography	7
F. Potable Water Supplies	7
G. Wetlands	8
III. Existing Sewage Facilities in the Planning Area	8
A. Existing Community Sewerage Systems.....	8
1. Description of Treatment Facilities, Receiving Stream, and Effluent Discharge Requirements	8
2. Wastewater Treatment Process	10
3. Existing Sewage Facilities Needs	10
4. Scheduled WWTP Upgrades	11
5. Operation and Maintenance	11
IV. Future Growth and Land Development	11
A. Municipal and County Planning Documents	11
1. Zoning and Comprehensive Plan	11
2. Floodplain, Stormwater Management, and Special Protection Areas	11
B. Projected Growth for Current Service Area	12
1. Existing Developments/Subdivisions	12

2.	Land Use Designations	12
3.	Future Growth Areas and Population Projection	12
4.	Zoning, Subdivision Regulations, Comprehensive Plans, or Other Plans Related to Use and Protection of Land and Water Resources	13
5.	Sewage Planning Necessary to Provide Adequate Wastewater Treatment for Five and Ten Year Planning Horizons	13
V.	Alternatives to Provide New or Improved Wastewater Treatment Facilities.....	13
A.	Conventional Treatment and Discharge Alternatives	13
1.	Regional Treatment	13
2.	Service Area Expansion	14
3.	Continued Use of Existing Treatment Facilities	14
4.	Collection and Conveyance Repair or Replacement	16
5.	New Community Sewage Systems	16
6.	Innovative/Alternative Methods	17
B.	No-Action Alternative.....	17
1.	Water Quality and Public Health	17
2.	Growth Potential	17
3.	Community Economic Conditions	17
4.	Recreational Opportunities	18
5.	Drinking Water Sources	18
6.	Other Environmental Concerns	18
VI.	Evaluation of Alternatives	18
A.	Consistency Evaluation	19
1.	Clean Streams Law.....	19
2.	Municipal Wasteload Management Annual Reports	19
3.	Title II of the Clean Water Act	19
4.	Comprehensive Planning	20
5.	Antidegradation Requirements	20
6.	State Water Plans	20
7.	Pennsylvania Prime Agricultural Land Policy	21
8.	County Stormwater Management Plans	21
9.	Wetland Protection	21
10.	Protection of Rare, Endangered or Threatened Plant and Animal Species	22
11.	Historical and Archaeological Resource Protection	22

	B.	Resolution of Inconsistencies	22
	C.	Applicable Water Quality Standards Evaluation	22
	D.	Estimated Costs, Present Worth Analysis, and Other Factors	22
	1.	Construction and Project Costs	22
	2.	Operation and Maintenance Costs.....	25
	3.	Present Worth Analysis	25
	E.	Analysis of Funding Methods	25
	F.	Immediate and Phased Implementation Analysis	30
	G.	Administrative Organization Evaluation	30
VII.		Institutional Evaluation	30
	A.	Existing Wastewater Treatment Authority Analysis	30
	B.	Institutional Alternatives Needed to Implement Proposed Technical Alternative	30
	C.	Administrative and Legal Activities for Implementation of Recommended Technical Alternative	30
	D.	Institutional Alternative to Implement Recommended Technical Alternative	31
VIII.		Implementation Schedule and Justification for Selected Technical Alternative	31
	A.	Technical Alternative Justification	31
	1.	Existing Wastewater Disposal Needs	31
	2.	Future Wastewater Disposal Needs	31
	3.	Operation and Maintenance Considerations	31
	4.	Cost-Effectiveness	32
	5.	Available Management and Administrative Systems	32
	6.	Available Funding Methods	32
	7.	Environmental Soundness and Compliance	32
	B.	Financing Plan.....	32
	C.	Implementation Schedule	32
IX.		Environmental Report	A
	A.	Environmental Report (ER) via Uniform Environmental Review (UER) Process	A

LIST OF TABLES

1. NPDES Effluent Limitations (9/1/2015 – 5/31/2018)..... 9

2. NPDES Effluent Limitations (6/1/2018 – 8/31/2020)..... 9

3. Preliminary Opinion of Probable Construction and Project Costs (Alternative “A”) 23

4. Preliminary Opinion of Probable Construction and Project Costs (Alternative “B”) 24

5. Current and Projected Operation and Maintenance Costs 26

6. Methodology Summary – Economic Evaluation of Alternatives 27

7. Present Worth Analysis of Proposed Alternatives 28

8. Projected User Rates for Alternate B 29

9. Proposed Implementation Schedule..... 33

APPENDICES

A. Environmental Report Attached separately

B. Plan of Study 35

C. Act 537 Plan Content and Environmental Assessment Checklist..... 53

D. Planning Area 68

E. Existing Wastewater and Water Service Areas 69

F. Soil Survey 70

G. Wetlands Mapping 74

H. Existing Wastewater Treatment Facilities 79

I. Existing Plant Schematic..... 80

J. Turbotville Borough Zoning Map 81

K. FEMA Flood Map 82

L. Alternative A: Connection to Milton Regional Sewer Authority 84

M. Alternative B: SBR Phases of Operation 85

N. Alternative B: WWTP Upgrade Geometry Plan..... 86

O. Pennsylvania Natural Diversity Inventory Receipt 87

P. Cultural Resource Notice and PHMC Review 93

Q. Public Notice of Study Review and Comment Opportunity and Proof of Publication 101

R. Review Request Letters to Planning Entities and Proofs of Receipt 106

S. Comments Received on Special Study and Borough Responses 113

T. Turbotville Borough Resolution to Adopt Special Study..... 118

Plan Summary

Summary of Act 537 Special Study Borough of Turbotville, Northumberland County

A. Service Area and Major Problems

The planning area is the existing wastewater treatment plant (0.87 acre). Effectively, the planning area is restricted to the area involved with the wastewater treatment facilities as no activities are proposed within or beyond the current wastewater service area of Turbotville Borough.

The area served by the Turbotville Borough-owned sewer system is shown on the map provided in **Appendix E**. The sewer service area is located entirely within the Borough of Turbotville and only includes areas currently served by the Borough sewer system.

The existing wastewater treatment plant has neared the end of its useful life, and at times, has struggled to meet its permitted effluent limits. Since 2009, the Borough has been exploring options to rehabilitate or replace the Plant. Additionally, with the issuance of the renewed NPDES Permit in 2015, the Borough will be subject to more stringent effluent limitations (see **Table 2**) that the existing Plant is not capable of achieving for Ammonia, Total Phosphorus, and Total Copper.

B. Selected Alternative

To allow the Borough to meet its current and future NPDES permit limits, this Study has recommended Alternative B: Upgrade of the Existing WWTP.

No additional institutional arrangements will be needed to implement this Alternative as the WWTP is currently owned, operated, and maintained by the Borough.

C. Cost Estimate

The estimated Construction Cost of Alternative B: WWTP Upgrade is \$3,033,826.

The estimated Project Cost of Alternative B: WWTP Upgrade is \$3,943,974.

To finance the proposed project, the Borough will apply for a funding package from PENNVEST. Additionally, the Borough will seek sources of grant funds to help reduce any future loan principal amount.

D. Municipal Commitments

No municipal commitments are needed to implement the recommendations of this Study beyond adoption of this Special Study by the Borough of Turbotville. The Borough will take normal Council actions as it moves forward with the design, permitting, funding, and construction activities.

E. Implementation Schedule

To implement the recommendations of this Study, the following schedule is proposed:

Submit WQM Part II Permit Application	May 5, 2017 (estimate)
Apply for PENNVEST funding	August 2017 (TBD)
Advertise for Bids	December 2017
Open Bids/Award Contract	February 2018
Begin Construction	March 2018
Complete Construction	Winter 2018/2019

Plan Content

I. PREVIOUS WASTEWATER PLANNING

A. Past Wastewater Planning Impact on Current Planning Effort

1. Previous Act 537 Planning

Turbotville Borough

The most recent Act 537 Plan for the Borough of Turbotville was prepared in December 1984, by Buchart-Horn, Inc. Since then, Wellington Estates has been the only approved subdivision (2007). Having 12 lots, Wellington Estates is served by the existing wastewater treatment plant (WWTP). The WWTP was upgraded in 1989, expanding its capacity from 0.048 MGD to 0.100 MGD. The WWTP was again upgraded between 1990 and 2013, increasing its capacity from 0.100 MGD to 0.136 MGD.

Lewis Township

Lewis Township shares common borders with Turbotville Borough. In 2001 Lewis Township began the process of evaluating its Township wastewater needs. The Lewis Township wastewater planning activity was conducted in accordance with the Official Sewage Facilities Planning process commonly known as Act 537 planning.

The Lewis Township Act 537 plan was completed and approved in mid-2007. The plan included sending 15,000 gpd (0.015 mgd) of flow to the Turbotville wastewater treatment plant. The Lewis Township plan concluded that the Township would construct small diameter force main and individual grinder units along SR 0054 known in the plan as Area B. Lewis Township would also construct small diameter force main and individual grinder units along T660 Schell Road known in the plan as Area C. Areas B and C would be conveyed through the existing Turbotville collection system to the Turbotville wastewater treatment plant.

Lewis Township and Turbotville Borough entered into an Intermunicipal Agreement dated January 31, 2011 governing the details of the wastewater service to be provided by Turbotville Borough to Lewis Township. The agreement maintained the initially contemplated reserve hydraulic capacity of 15,000 gpd. In addition, the agreement established organic reserve capacities of 25.01 pounds per day of BOD₅ as well as 29.27 pounds per day of total suspended solids. These three loading limitations were agreed to be measured on a 24-hour basis and averaged over a calendar month.

As of the writing of this Turbotville Borough Act 537 Special Study, Lewis Township has not constructed the aforementioned sewer systems. Turbotville Borough will conduct its study analysis by continuing to honor its capacity obligations as required by its Intermunicipal Agreement with Lewis Township.

2. Unaddressed Planning in Approved Plan Implementation Schedule

There is no unaddressed planning at this time.

3. Anticipated or Proposed Planning by Sewer Authority or Approved Under Chapter 94 Corrective Action Plan
There is not any anticipated sewage planning by the Borough through an approved Chapter 94 Corrective Action Plan.
4. Planning Modules for New Land Development, Planning “Exceptions”, and Addenda Sewage Planning Exemption was received September 6, 2007 for Wellington Estates Subdivision, containing 12 lots to be serviced by the public sewer system in the Borough of Turbotville.

II. PHYSICAL AND DEMOGRAPHIC ANALYSIS

A. Planning Area and Wastewater Service Area

The planning area (**Appendix D**) is the existing wastewater treatment plant (0.87 acre). Effectively, the planning area is restricted to the area involved with the wastewater treatment facilities as no activities are proposed within or beyond the current wastewater service area of Turbotville Borough. In other words, this *Special Study* does not address any proposed modifications or extensions to the existing wastewater collection or conveyance systems. Nonetheless, factors from outside the planning area are addressed in regard to their related impact on the current treatment facility and proposed technical alternative.

The area served by the Turbotville Borough-owned sewer system is shown on the map provided in **Appendix E**. The sewer service area is located entirely within the Borough of Turbotville. In addition to the sewer service area, the existing public water service area, served by the Turbotville Municipal Authority is also depicted on this map. The Authority’s public water system serves two areas in Lewis Township: Schell Road and the Warrior Run school complex.

B. Physical Characteristics

The planning area is located at the northwest corner of Turbotville Borough and is bordered by an Unnamed Tributary to Warrior Run to the west, RJ Corman Railroad (Norfolk Southern) to the north, and Adam Street to the south. Warrior Run has a Chapter 93 stream classification of Warm Water Fishery, Migratory Fish (WWF, MF) and drains to the West Branch Susquehanna River in Northumberland County. The existing plant’s effluent flows into the unnamed tributary directly downstream of the plant. The surrounding area is mostly residential within the Borough and primarily farmlands and pastures outside of the Borough. Between the existing treatment plant fence and the railroad to the north is a small drainage ditch that flows into the unnamed tributary to Warrior Run.

C. Soils

The soils located within the planning area are soil types WbA (Watson Silt Loam) and WeC (Weikert Channery Silt Loam). The Watson Silt Loam covers 95 percent of the planning area according to the soil survey (**Appendix F**). WbA is considered a Prime

Agricultural Soil while WeC is not. Though Watson silt loam is considered a prime farmland soil, the planning area is not currently used for agricultural purposes. Neither soil type identified within the planning area is considered hydric. Although the soil survey lists these two soils within the planning area, it is possible that there are other soil classifications present. The existing site has previously been disturbed multiple times during the wastewater treatment plant's initial construction and subsequent renovations. It is assumed that fill and structural fill was brought in from outside of the area.

D. Geologic Features

Three major geologic formations exist within the planning area:

- Silurian era, Will Creek Formation – variegated gray, interbedded calcareous shale, siltstone, sandstone, and limestone and dolomite
- Devonian and Silurian era, Keyser and Tonoloway formations (undivided) – medium-gray fossiliferous limestone and medium-gray mud-cracked limestone containing some shale and sandstone interbeds
- Devonian era, Onondaga and Old Port formations (divided) – medium-gray calcareous shale, marine fossils, very coarse grained sandstone, siltstones, chert, shale and limestone.

In 1998, the DEP performed a study to find where the Nitrogen-Nitrate concentrations were in excess of 5.0 mg/l in the Lewis Township and Turbotville Borough area. Although some residences were found to exceed 5.0 mg/l, none were located in the current planning area or within Turbotville Borough.

E. Topography

The topography of the planning area is depicted on the map of the Planning Area (**Appendix D**). To the west, the Unnamed Tributary to Warrior Run Creek bounds the planning area. On the north side of the planning area a drainage ditch separates the fence and the railroad. The maximum relief across the planning area is approximately 8 feet, from elevation 536 at the southern boundary to 528 at the north-western boundary. The planning area is occupied by the existing wastewater treatment plant.

The planning area and Turbotville service area is served completely by a public sewer system. The planning area, as an existing wastewater treatment plant, was not evaluated for suitability for onlot sewage disposal systems.

F. Potable Water Supplies

The Turbotville Municipal Authority – Public Water System provides the planning area and the Borough of Turbotville with potable water. The water system is served by a spring source which is treated at the existing Water Treatment Plant. In addition to the Borough water service area identified in **Appendix E**, the water system serves a small area along Schell Road and the Warrior Run School complex. There are no wells located within the planning area, and the public water system is fully capable of providing

adequate water service to all customers throughout the planning area, as well as the sewer service area.

G. Wetlands

According to the U.S. Fish and Wildlife Service National Wetlands Inventory (**Appendix G**), there are no wetlands present in the planning area. Of the two non-hydric soils, WbA and WeC, located in the planning area (**Appendix F**, Soil Map mentioned above), each soil has a hydric component of 5% and 1%, respectively. No wetlands will be impacted within the Planning Area.

III. EXISTING SEWAGE FACILITIES AND NEEDS IN THE PLANNING AREA

A. Existing Community Sewerage Systems

Within the Planning Area, the only sewage system is the existing public wastewater collection and treatment system owned and operated by the Borough of Turbotville. The maps provided in **Appendices D and E** show the location of these facilities.

1. Description of Existing Sewage Facilities

The Borough of Turbotville's Wastewater Collection System consists of approximately 3.5 miles of 6- and 8-inch diameter sewer mains. In the 1990's two-thirds of the collection system was rehabilitated through slip-lining. The Borough also operates a grinder pump located on Washington Street that serves two connections.

All sewage flows by gravity to the existing wastewater treatment plant located in the Planning Area, at the northwest corner of the Borough. **Appendix H** depicts the existing Wastewater Treatment Plant. The wastewater treatment plant (NPDES Permit No. PA0028100) is permitted for a design flow rate of 0.136 MGD, and the design influent mass organic loading rate of 227 lbs/day BOD5. Treated effluent is discharged to Unnamed Tributary to Warrior Run, within the West Branch Susquehanna River drainage basin. The plant's current and projected effluent discharge requirements are shown in **Tables 1 and 2**. The most recent NPDES permit issued for the plant provide two separate Effluent Limitations: Permit issuance through May 31, 2018 (Table 1) and June 1, 2018 through August 31, 2020 (Table 2). The highlighted values will become more stringent after June 1, 2018.

**Table 1: NPDES Effluent Limitations
September 1, 2015 through May 31, 2018**

Parameter	Average Monthly (lbs/day)	Weekly Average (lbs/day)	Average Monthly (mg/L)	Weekly Average (mg/L)	Instant. Maximum (mg/L)
pH	--	--	--	--	6.0 min/9.0 max
Total Residual Chlorine	--	--	0.45	--	1.48
CBOD ₅	13	20	12	18	24
Total Suspended Solids	34	34	30	30	30
Fecal Coliform (CFU/100 mL) May 1 – Sep 30	--	--	200 Geo Mean	--	1,000
Fecal Coliform (CFU/100 mL) Oct 1 – Apr 30	--	--	2,000 Geo Mean	--	10,000
Ammonia-Nitrogen May 1 – Oct 31	7.0	10	6.0	9.0	12
Ammonia-Nitrogen Nov 1 – Apr 30	20	31	18	27	36
Total Phosphorus	Report	Report	Report	Report	--
Total Copper	Report	Report	Report	Report	--
Total Lead	Report	Report	Report	Report	--

**Table 2: NPDES Effluent Limitations
June 1, 2018 through August 31, 2020**

Parameter	Average Monthly (lbs/day)	Weekly Average (lbs/day)	Average Monthly (mg/L)	Weekly Average (mg/L)	Instant. Maximum (mg/L)
pH	--	--	--	--	6.0 min/9.0 max
Total Residual Chlorine	--	--	0.45	--	1.48
CBOD ₅	13	20	12	18	24
Total Suspended Solids	34	34	30	30	30
Fecal Coliform (CFU/100 mL) May 1 – Sep 30	--	--	200 Geo Mean	--	1,000
Fecal Coliform (CFU/100 mL) Oct 1 – Apr 30	--	--	2,000 Geo Mean	--	10,000
Ammonia-Nitrogen May 1 – Oct 31	4.0	5.5	3.5	5.0	7.0
Ammonia-Nitrogen Nov 1 – Apr 30	11.5	17	10.5	15	21
Total Phosphorus	2.96	2.96	2.60	2.60	2.60
Total Copper (µg/L)	0.04	0.08 Daily Max	36.31	72.62 Daily Max	90.77
Total Lead	Report	Report	Report	Report	--

2. Wastewater Treatment Process

The wastewater treatment plant is permitted for a discharge of 0.136 MGD under NPDES Permit PA0028100. **Appendix I** provides a schematic of the existing wastewater treatment process. All wastewater flows via a gravity collection system to a 0.250 MGD maceration chamber where it passes through a 0-300 gpm macerator. The chamber is also equipped with a manual by-pass bar screen. The wastewater then flows by gravity to a 0.250 MGD pumping station where it is pumped to two 50,000-gallon extended aeration tanks where biological treatment occurs. Sludge recirculated from the secondary settling basins is mixed with preliminary effluent and air is introduced via non-clogging coarse air diffusers to provide treatment. The biologically-activated effluent from the aeration tanks flows by gravity to two clarifiers. Secondary effluent from the clarifiers flows by gravity to two 2,100-gallon chlorine contact tanks for disinfection with chlorine tablets and is finally discharged to an unnamed tributary of Warrior Run (a tributary of the West Branch of the Susquehanna River). The Borough does not utilize any other disposal areas for effluent.

The sludge wasted from the activated sludge process is pumped via two 3" 0-105 gpm air lift pumps located in the secondary settling basin to a 29,700 gallon aerobic digestion tank. Stabilization and thickening occurs in the aerobic digestion tank. The thickened stabilized sludge is pumped to the sludge drying beds where it is dewatered, removed and hauled to an approved landfill at a rate of 16 dry tons per year at the Lycoming County landfill.

3. Existing Sewage Facilities Needs

The Borough of Turbotville is not currently in violation of its NPDES permit, Clean Streams Law permit, nor is there an existing or projected hydraulic or organic overload under 25 Pa. Code Chapter 94. The existing wastewater treatment plant, however, has neared the end of its useful life, and at times, has struggled to meet its permitted effluent limits. Since 2009, the Borough has been exploring options to rehabilitate or replace the Plant. Additionally, with the issuance of the renewed NPDES Permit in 2015, the Borough will be subject to more stringent effluent limitations (see **Table 2**) that the existing Plant is not capable of achieving for Ammonia, Total Phosphorus, and Total Copper. The Borough must take some form of action to meet its upcoming NPDES Permit effluent limitations.

The Plant, while not hydraulically overloaded, has received significant amounts of inflow and infiltration from the collection system. For the past 3 years, the Borough has worked to identify and eliminate sources of inflow and infiltration. Additionally, flows received at the plant have been monitored to determine average flow rates as well as peak wet weather flow rates. Though I&I are always a concern, the 2015 Chapter 94 Report for the Borough showed that the Plant received an annual average flow of 0.052 MGD and maximum 3-month average of 0.058 MGD during

2015 with a five-year average flow of 0.051 MGD, all significantly below the plant's capacity of 0.136 MGD.

4. Scheduled WWTP Upgrades

As of this Special Study, there are no scheduled or in-progress upgrades or expansions of the wastewater treatment facilities. Though as mentioned above, the Borough has been exploring options to upgrade or replace the existing wastewater treatment plant since 2009.

5. Operation and Maintenance

The Borough provides operation and maintenance of the sewage collection and treatment system. Two Borough employees are responsible for the day to day activities of the sewage collection system and treatment plant. The Borough has contracted with a part-time licensed operator to ensure the Treatment Plant is operated according its permit requirements. All operational decisions are made by the licensed operator.

IV. FUTURE GROWTH AND LAND DEVELOPMENT

A. Municipal and County Planning Documents

Zoning and Comprehensive Plan

In June of 2005, the Borough of Turbotville adopted the County of Northumberland's Comprehensive Plan. The County reviews all land development and subdivision plans submitted to the borough.

The Borough has adopted the Zoning Ordinance of 2014. The zoning map for Turbotville Borough is attached as **Appendix J**.

The Planning Area is located within the Residential Town (RT) zone. The Borough also includes Residential Urban (RU), Downtown Commercial (CD), Commercial Manufacturing (CM), and Highway Commercial (HC) zones. The Zoning Ordinance does not restrict minimum lot size based upon the presence of public sanitary sewer or water service within the RT zone. The existing land use of the Planning Area is a wastewater treatment facility, which is included in the Zoning Ordinance's definition of "Essential Service" and is an appropriate use within this zone. Proposed land use for this Planning Area will remain a wastewater treatment plant.

Floodplain, Stormwater Management, and Special Protection Areas

Floodplains

In reviewing flood mapping provided by the Federal Emergency Management Authority (FEMA) for the Borough of Turbotville, there is no defined 100-year floodplain identified within the Planning Area. A copy of the Flood Insurance Rate Map (FIRM) for this area is included in **Appendix K**.

In the absence of a defined floodway for a waterway, Federal and State regulations require a 50-foot wide area beyond the stream bank to be considered the floodway. This 50-foot wide floodway boundary for UNT to Warrior Run is shown on the maps

included in **Appendix D**. The treatment alternative selected for implementation in this Study will be constructed outside of the current 50-wide floodway in the Planning Area.

Stormwater Management (Watershed-specific) Areas

The jurisdiction of Northumberland County's Stormwater Management Plan covers the Borough of Turbotville as does the county's Land Development Regulations. The Stormwater Management Plan is a component of the land development regulations and will be required for any proposed upgrades.

Chapter 93 Special Protection Areas

The only waterway within the Planning Area is the Unnamed Tributary to Warrior Run. The stream has a Chapter 93 designated and existing use classification of Warm Water Fishery, Migratory Fish (WWF, MF) and drains to the West Branch Susquehanna River in Northumberland County. This area is not identified as a special protection area.

B. Projected Growth for Current Service Area

Existing Developments/Subdivisions

Wellington Estates Subdivision was submitted to the Turbotville Borough in 2007. It proposed a 12-lot, single family, residential subdivision with each lot being served by public sewer and water. In September 2007, the PA DEP granted the Borough a planning exemption for Wellington Estates. To date, one (1) lot has been developed. The Borough does not anticipate any additional subdivisions at this time.

Land Use Designations

The Planning Area is located within the Borough's Residential Town (RT) zone. The existing land use of the Planning Area is a wastewater treatment facility, which is included in the Zoning Ordinance's definition of "Essential Service" and is an appropriate use within this zone. Proposed land use for this Planning Area will remain a wastewater treatment plant. The wastewater treatment plant upgrade will comply with the requirements of the land development regulations that set by the Borough of Turbotville and Northumberland County, as this special study will describe.

Future Growth Areas and Population Projection

Between 2000 and 2010, the population of the Borough of Turbotville increased by 2.0%, from 691 to 705 people, according to the 2000 and 2010 United States Census (0.2% per year). The current number of Equivalent Dwelling Units for the Borough's sewer service area is 365.5 EDUs. Assuming a continued 2.0% growth rate since 2010 and over the next 20 years, the Borough's population is projected to be 744 people by 2037. A similar increase in the number of EDUs projects the sewer system will serve 382 EDUs by 2037. Additionally, future growth should account for the 15,000 GPD from Lewis Township, as previously discussed. As the existing wastewater treatment plant is currently at only 38% capacity, this projected growth will not overload the treatment plant. Assuming the current flow rate per EDU of 52,000 GPD/365.5 EDUs, or 142 GPD/EDU, the projected 2037 flow rate to the treatment plant is 54,350 GPD, plus 15,000 GPD from Lewis Township, for a total flow of 69,350 GPD, or 51% of the existing plant's 136,000 GPD capacity.

Zoning, Subdivision Regulations, Comprehensive Plans, or Other Plans Related to Use and Protection of Land and Water Resources

All applicable zoning, subdivision regulations, comprehensive plans, or other plans related to use and protection of land and water resources have heretofore been addressed in this study report. It is believed that the proposed activity will be fully compliant with all rules and regulations to which it is subject.

Sewage Planning Necessary to Provide Adequate Wastewater Treatment for Five and Ten Year Planning Horizons

In evaluating the proposed alternatives for upgrading the Turbotville wastewater treatment facility, the proposed planning period will be 20 years. This planning activity will take into account all factors (e.g., residential growth rate, commercial and industrial development potential, and future treatment requirements).

V. IDENTIFY ALTERNATIVES TO PROVIDE NEW OR IMPROVED WASTEWATER DISPOSAL FACILITIES

For the purposes of this Special Study, three alternatives have been evaluated to address the sewage facilities needs of the Planning Area and Turbotville Borough sewer service area:

1. Connection to Milton Regional Sewer Authority (Alternative A)
2. Replacement and Upgrade of the Existing Turbotville WWTP (Alternative B)
3. No Action

These three alternatives will be further explored throughout this Study.

A. Conventional Treatment and Discharge Alternatives

1. Regional Treatment

The Special Study has evaluated the alternative of regionalizing treatment with a nearby community. The closest community with sufficient wastewater treatment capabilities is the Milton Regional Sewer Authority, approximately 8.5 miles away from the Borough. This alternative would include the following components:

- The Borough would continue to collect raw sewage through the existing collection system.
- Sewage would flow by gravity to the site of the current Turbotville wastewater treatment plant.
- A new Raw Sewage Pump Station would be constructed at the site of the existing Turbotville wastewater treatment plant.
- Raw sewage would be pumped to the Milton Regional Sewer Authority facilities through 8.7 miles of force main. All force main would follow State or Local roads.
- All sewage collected from Turbotville Borough would be treated at the MRSA WWTP.
- The existing Turbotville WWTP would be decommissioned and demolished.

This proposed Alternative A is graphically depicted on the map in **Appendix L**. As will be demonstrated further in the Study, though technically feasible, conveying sewage to the MRSA is not the most cost-effective alternative.

2. Service Area Expansion

As discussed in Section I.A.1 of this Study, the Borough of Turbotville and Lewis Township have entered into an Intermunicipal Agreement dated January 31, 2011 to send 15,000 gallons per day of sewage from Lewis Township to the Turbotville WWTP. In addition, the agreement established organic reserve capacities of 25.01 pounds per day of BOD₅ as well as 29.27 pounds per day of total suspended solids. The Borough continues to honor this commitment to Lewis Township despite no construction of sewage facilities by the Township.

The remaining population outside the Borough's current service area is rural and scattered; the cost per EDU to expand the service area to these possible customers would be very high and there is not any political or regulatory desire to accomplish this expansion. Consequently, unless there is significant justification in the years ahead, the Turbotville service area will remain as currently defined.

3. Continued Use of Existing Facilities

The current wastewater treatment plant has exceeded its useful life in regard to both physical condition and treatment capabilities. One of the alternatives investigated in this study is a renovation of the existing WWTP involving facility replacements and additions. The status of the current treatment plant has been thoroughly investigated and was previously discussed in Sections III.A.1 and 3 of this Special Study. To provide long-term reliable treatment of the Borough's sewage and to meet the upcoming effluent limitations as defined in the current NPDES permit, the Borough has explored the alternative of upgrading the existing wastewater treatment plant (Alternative B). As the Borough is projected to meet its five-year projections for hydraulic and organic capacities per Chapter 94, this alternative does not propose an increase or reduction of the hydraulic or organic loading capacity.

In exploring treatment processes, the Borough is evaluating a Sequencing Batch Reactor (SBR) sized to remove organic matter, ammonia (via nitrification process), total nitrogen (via denitrification process), and total phosphorus (via chemical process). For this Study, the SBR has been designed around the Aqua-Aerobic Systems, Inc. system though the treatment process is available from several different manufacturers to allow for competitive pricing. **Appendix M** provides a summary of the SBR Phases of Operation.

Two SBR tanks would be constructed and all biological treatment necessary to meet current and upcoming effluent limits would be accomplished in these tanks. In addition, the project will include an influent grinding system, triplex raw sewage pumps, chemical feed systems, post-equalization, ultraviolet disinfection, aerobic sludge digesters, and an emergency generator. The proposed WWTP upgrade will also include an alternate for sludge dewatering and disposal facilities. **Appendix N** provides a Site Plan of the proposed WWTP upgrade.

The SBR process was selected over other treatment processes, such as separate aeration basins and settling tanks, due to space restrictions at the existing WWTP site. An advantage of SBR technology is its smaller footprint requirement. The dual SBR units can be constructed on available land at the site while the existing treatment facilities remain in service, a critical necessity. To construct a separate WWTP using separate aeration basins and clarifiers would require the purchase of adjacent land and expansion of the Borough's existing property. The Borough desires to keep all wastewater treatment confined to the existing fenced-in area on property currently owned by the Borough.

Key components of the **WWTP Upgrade Alternative** are identified as follows:

Influent Pump Station

The existing raw sewage pump station would be replaced with a new triplex pump station capable of handling design flows with one pump out of service. The usage of a triplex station provides the Borough with the flexibility of handling a wide range of dry and wet weather flows. The raw sewage wet well would include a sewage grinder or comminuter to protect the pumps and downstream equipment.

Sequencing Batch Reactor (SBR) Basins: The SBR treatment system will be provided as the treatment component for removal of organic (carbonaceous) matter, ammonia (via nitrification process), and total nitrogen (via denitrification process). This system represents a fill-and-draw, non-steady state, activated sludge (suspended growth) process in which a reactor basin is filled with wastewater during a discrete time period, and then operated in a batch mode. The SBR will accomplish influent and effluent flow equalization, mixing, aeration, and clarification in a timed sequence in a single reactor basin. By varying the operating strategy, alternating aerobic and anoxic conditions will be achieved to encourage the growth of desirable micro-organisms (**Appendix M**). The process is ideally suited when nitrification, denitrification, and biological or chemical phosphorous removal are required to achieve regulatory discharge requirements. Two SBR basins (0.147 MG each) would be constructed and all biological and chemical treatment necessary to meet current and anticipated standards would be accomplished in these tanks. Retrievable fine bubble diffusers and a floating mechanical mixer will be utilized in each basin to maintain desired dissolved oxygen levels and mixing. Automated controls will be utilized to regulate all operational parameters, including treatment cycle phases, aeration and mixing coordination, chemical feed rates for phosphorus removal and pH adjustment, and discharge flow rates from the associated post-equalization tank.

Aerobic Digesters

Waste activated sludge from the SBR process would be pumped to the adjacent parallel aerobic digesters. Digested sludge will be pumped to the existing Sludge Drying Beds, to remain in service, or to a future sludge dewatering process, such as a belt filter press prior to disposal off site.

Ultraviolet Disinfection System: In consideration of the emphasis on safety issues, anti-degradation regulations to protect water resources, and the growing potential

that chlorination facilities will be phased out by regulatory action, an alternate means of disinfection is being proposed as a component of the upgrade project. Accordingly, a UV system consisting of three parallel enclosed UV reactors, each with a treatment capacity of 0.136 MGD, will be installed in a dedicated building between the SBR tanks and the existing outfall. Three identical units would provide redundancy for the average monthly flow while also providing up to 0.408 MGD of capacity for peak flow events. Effluent from the SBR post-equalization tank would be directed, at a regulated flow rate, to the UV system for disinfection and then to the existing outfall to the Unnamed Tributary to Warrior Run. System controls will automatically regulate the number of UV reactors engaged and the UV intensity level of each unit in operation, based upon the monitored discharge rate from the SBR post-equalization tank and the respective performance status of the UV reactors.

4. Collection System Repair or Replacement

The Borough of Turbotville has continually addressed the inflow and infiltration within its collection and conveyance system. While I&I is recognized by the Borough as a problem requiring ongoing maintenance, the endeavors to date have been very effective and I&I is not considered a major issue. Nonetheless, the influence of the more persistent I&I must be taken into account in designing hydraulic components at the treatment plant.

For the past 3 years, the Borough has worked to identify and eliminate sources of inflow and infiltration. Additionally, flows received at the plant have been monitored to determine average flow rates as well as peak wet weather flow rates. The following work has been completed to date:

- September 2014 – Smoke testing of the Broadway Street drainage area to identify potential sources of I&I.
- 2015 and 2016 – Manhole rehabilitation – Identified manholes within the system as sources of inflow and infiltration. Borough began sealing the manhole connections.
- 2013 – 2016 – Monitoring of WWTP flows to determine peak flows (wet weather influenced) received at the WWTP
- 2016 – Flow monitoring of system flows utilizing temporary flow loggers. These devices are placed in the flow channel of a manhole to log the flow rates over time. The Borough can relocate the loggers as needed to isolate sections of sewer with higher wet weather influenced flows. These loggers have also provided data used to determine the peak flow rates that any WWTP upgrade will need to handle. Based on the metered flows, any WWTP project will need to handle flows that range from 30,000 to 300,000 gallons per day (GPD).
- Future – Virgin Alley Sewer Replacement – The last section terra-cotta sewer in the Borough will be replaced with PVC and various manholes will be sealed to prevent infiltration around liner installations.

5. New Community Sewage Systems

The Planning Area and the Borough's sewer service area are presently served by a public wastewater treatment collection and treatment system. There is not a need for a new or additional sewage system and/or treatment facility.

6. Innovative/Alternative Methods

The Planning Area and the Borough's sewer service area are presently served by a public wastewater treatment collection and treatment system. There are no areas requiring sewage service that would require innovative or alternative methods of collection and conveyance of sewage.

B. No-Action Alternative

The short-term and long-term impacts of no action or doing nothing to address the Planning Area's existing sewage needs are as follows:

1. Water Quality/Public Health

The anticipated short term impacts of a no-action alternative are as follows:

- NPDES Permit violations for effluent quality. Without an upgrade of the existing WWTP, the Borough would most likely not be able to meet upcoming effluent limitations for Ammonia Nitrogen and Total Phosphorus.
- Water quality in receiving stream (UNT to Warrior Run) would begin to deteriorate as treatment process failures become more prevalent due to equipment breakdowns. Because of the age and condition of the existing plant, problems could be abrupt and of a severity that permitted effluent limitations would be exceeded; the water quality of the receiving stream could thus be degraded and beneficial uses impacted.
- Public health concerns would be heightened as deteriorating water quality would increase the probability of waterborne diseases and discourage usage of receiving stream for water supply, agricultural, and recreational purposes.

In the long term, the noted short-term impacts would become more severe. Potential water quality degradation could reach a level where difficulty and longevity of stream recovery would be increased. Greater degradation would be coupled with a greater public health risk.

2. Growth Potential

While the existing WWTP is currently at 38% of its hydraulic capacity and 32% of its organic capacity, providing plenty of room for growth, the Borough may have to restrict growth and connections if it is in repeated violation of its NPDES permitted effluent limits. This potential connection prohibition would restrict growth of residential population as well as commercial interest in the Borough in both the short term and long term.

3. Community Economic Conditions

Similar to the restriction on residential growth potential described above, if the WWTP cannot meet its permitted effluent limits, a forthcoming connection prohibition would limit new businesses from coming to the service area and would limit existing businesses from expanding operations. Restrictions on both new and existing businesses would have a negative long-term impact on job creation in the Borough.

4. Recreational Opportunities

The WWTP's receiving stream, UNT to Warrior Run, and Warrior Run are both classified as a Warm Water Fishes (WWF) streams. Neither stream is stocked with trout or considered a Class A Wild Trout Stream. Beyond local fishing for warm water fish species, there is low recreational use of these streams before the confluence with the West Branch Susquehanna River. The West Branch Susquehanna River (approximately 6 miles downstream) provides many recreational opportunities for fishing and boating. The short and long-term impact of no action would be potential water quality degradation that could reach a level where fish species would be affected, thus reducing the recreational opportunities of the streams.

5. Drinking Water Sources

Any decrease in the water quality of UNT to Warrior Run and Warrior Run would have an obvious negative impact on the downstream use of this stream as a drinking water supply by current and future users. This influence would apply to both Warrior Run and the West Branch Susquehanna River. According to the Pennsylvania Department of Environmental Protection's eMapPa website, there are no permitted surface water withdrawals for drinking water on Warrior Run.

6. Other Environmental Concerns

The water quality of Warrior Run is important to the many agricultural operations along its banks. Farmers use water from this stream for irrigation, watering of livestock, and other agricultural applications. Dwindling water quality would result in these uses being encumbered by greater restrictions or excluded.

VI. EVALUATION OF ALTERNATIVES

Wastewater management alternatives developed as part of the Act 537 planning process must be evaluated in respect to the goals and objectives of the various planning, environmental, and natural resource laws and policies of the Commonwealth of Pennsylvania. Chapter 71.21(a)(5) of DEP's regulations requires that the Act 537 Plan address the consistency of each wastewater management alternative with eleven of the Commonwealth's goals and policies. If a recommended alternative is determined to conflict with or is inconsistent with one of the goals and objectives, the conflict and inconsistencies must be resolved before DEP will approve the alternative.

The following sections discuss the eleven categories under the consistency analysis. Consistency analyses were performed for only those components related to this Special Study. Based on the following, it appears that the selected approach (Alternative B: Upgrade of the Existing Turbotville WWTP) is consistent with the criteria. Three alternatives were identified in Section V of this Special Study:

1. Connection to Milton Regional Sewer Authority (Alternative A)
2. Replacement and Upgrade of the Existing Turbotville WWTP (Alternative B)
3. No Action

A. Consistency Evaluation

Alternatives A and B, identified above and in Section V of this Study, were evaluated for consistency with various environmental regulations and cost effectiveness. The scope of this *Act 537 Special Study* is confined to wastewater treatment alternatives to meet the Borough's current and future NPDES Permit effluent limitations. The required sewage treatment capacity of the service area will remain as currently regulated under existing NPDES and WQM permits.

1. Clean Streams Law

Sections 4 and 5 of the Clean Streams Law require that consideration be given to water quality management and pollution control in a watershed as a whole. Whereas, Section 208 of the Clean Water Act calls for the development of wastewater plans that identify the facilities necessary to meet anticipated wastewater treatment needs for the future. This *Special Study* is consistent with the Clean Streams Law since it addresses the ability of the Borough of Turbotville to reliably meet future effluent limitations. Alternative A (Connection to MRSA) would be consistent with the Clean Streams Law in that the existing Turbotville WWTP effluent outfall would be eliminated. Alternative B (Turbotville WWTP Upgrade) is consistent with the Clean Streams Law in that current and future NPDES permitted effluent limits would be met.

2. Municipal Wasteload Management Annual Reports (Chapter 94)

Projected hydraulic and organic capacity requirements presented in the Borough's most recent Chapter 94 report are consistent with the projections and basic design criteria presented in this Study. The Borough does not require revised hydraulic or organic capacity.

Alternative A: The Milton Regional Sewer Authority is currently operating at 33% of its 4.25 million gallons per day capacity (MGD) and can handle the both the Borough's 5-year hydraulic projection of 53,200 GPD and 20-year projection of 54,350 GPD.

Alternative B: The proposed WWTP Upgrade would not alter the plant's current hydraulic capacity of 0.136 MGD, which is sufficient for both the 5-year and 20-year flow projections.

Both Alternative A and B can adequately treat the Borough's projected hydraulic and organic loadings. Furthermore, the Borough is not under any DEP imposed Corrective Action Plan.

3. Title II of the Clean Water Act

Title II of the Clean Water Act requires the development and implementation of wastewater treatment management plans and practices which provide the application of the best practical waste treatment technology before discharging into

receiving waters. Both alternatives presented in this Study are consistent with this requirement as practical waste treatment technologies. Alternative B has been selected for implementation and the proposed discharge will be as currently permitted regarding location and quantity (i.e., the treatment capacity will remain as permitted).

4. Comprehensive Planning

Both treatment alternatives are consistent with the Northumberland County's Comprehensive Plan which was adopted by the Borough of Turbotville in June 2005.

5. Antidegradation Requirements

Chapters 93 and 95 under Pennsylvania's Clean Stream Law classifies all surface waters according to uses to be protected and establishes water quality criteria which need to be maintained in the surface waters. The selected approach (Alternative B) in this study is consistent with these requirements as surface water discharges will remain as currently permitted.

Chapter 102 requires a Soil Erosion and Sediment Pollution Control Plan to be prepared and followed for any construction activity impacting greater than 5,000 square feet. An NPDES Permit for Stormwater Discharges Associated with Construction Activities is required for any disturbance greater than one (1) acre. Both Alternatives A and B will require a Chapter 102 Soil Erosion and Sediment Pollution Control Plan to be developed. Alternative A (Connection to MRSA) has a projected earth disturbance of 5.5 acres and will require an NPDES Permit for Construction. Alternative B will not require an NPDES permit as the entire existing WWTP site is 0.87 acre and no earth disturbance is proposed outside of this site. Before construction begins for the selected alternative (Alternative B), an erosion and sedimentation control plan will be prepared and approved by the appropriate agency.

Chapter 105 requires a permit for any crossing of waters of the Commonwealth. The proposed alignment of Alternative A (Connection to MRSA) will cross at least five streams and one wetland (**Appendix G**), requiring a Chapter 105 Water Obstruction and Encroachment Permit. Alternative B (WWTP Upgrade) does not propose any stream or wetland crossings.

Alternative A (Connection to MRSA) will require significantly more Federal and State permits than the selected Alternative B (WWTP Upgrade).

6. State Water Plans

The Pennsylvania Water Resources Planning Act (Act 220 of 2002) requires water plans to be prepared for all major watersheds within Pennsylvania. The Turbotville wastewater system is located within the West Branch Susquehanna River Watershed Region. No new surface water discharges are proposed under this

Special Study; therefore, the selected approach (Alternative B) is consistent with the state water plan.

7. Pennsylvania Prime Agricultural Land Policy

The Prime Agricultural Land Policy was established to protect prime agricultural land from irreversible conversions to uses that result in the loss of the land as an environmental or essential food source resource. The selected wastewater treatment alternative will be located upon the current treatment plant site.

The majority of the construction included in Alternative A (Connection to MRSA) will take place along local and State Roads, through previously disturbed soils. As such, Alternative A will not impact or result in the loss of Prime Agricultural Land.

The soils located within the defined planning area are soil types WbA (Watson Silt Loam) and WeC (Weikert Channery Silt Loam). The Watson Silt Loam covers 95 percent of the planning area according to the soil survey (**Appendix F**). Watson Silt Loam is considered a prime farmland soil while the Weikert Channery Silt Loam is not. Though Watson silt loam is considered a prime farmland soil, the planning area is not currently used for agricultural purposes. Although the soil survey lists these two soils within the planning area, it is possible that there are other soil classifications present. The existing site, and location for Alternative B, has previously been disturbed multiple times during the wastewater treatment plant's initial construction and subsequent renovations. It is assumed that fill and structural fill was brought in from outside of the area. Alternative B is consistent with the PA Prime Agricultural Land Policy.

8. County Stormwater Management Plan

The Northumberland County Subdivision and Land Development Ordinance covers the Borough of Turbotville and addresses stormwater management for new development. Stormwater Management will be a component of the selected treatment alternative (Alternative B). The County does not have an approved Act 167 Stormwater Management Plan for the Warrior Run watershed, therefore no conflict exists for either Alternative A or B.

9. Wetland Protection

Alternative A (Connection to MRSA) would require construction of 8.7 miles of force main installation, including five stream crossings and one wetland crossing as shown in the U.S. Fish and Wildlife Service National Wetlands Inventory mapping provided in **Appendix G**. This wetland is identified as PFO1A, a Freshwater Forested/Shrub Wetland.

According to mapping provided (**Appendix G**), there are no wetlands present in the Study's defined planning area. Therefore, the selected alternative (Alternative B) is consistent with the regulatory requirement to avoid or mitigate loss of wetlands.

10. Protection of Rare, Endangered or Threatened Plant and Animal Species

A search of the Pennsylvania Natural Diversity Inventory (PNDI) electronic database was done for selected wastewater treatment alternative (Alternate B – WWTP Upgrade). The PNDI Project Environmental Review Receipt (**Appendix O**) indicates that there are no known impacts to threatened and endangered species and/or special concern species and resources in the area designated for implementing the selected wastewater treatment alternative.

11. Historical and Archaeological Resource Protection

A Cultural Resource Notice was submitted to the Pennsylvania Historical and Museum Commission, Bureau of Historic Preservation for the Planning Area and the selected treatment alternative (Alternate B – WWTP Upgrade). A January 24, 2017 review letter was issued by PHMC indicating that the project will have no effect on historic properties. A copy of the completed Cultural Resource Notice and response letter are included as **Appendix P**. The selected alternative is consistent with the protection of historical and archaeological resources.

B. Resolution of Inconsistencies

Based on the above analyses, it does not appear that there are any inconsistencies, during the planning phase, between the selected wastewater treatment alternative (Alternative B) and the policies of the Commonwealth of Pennsylvania.

C. Applicable Water Quality Standards Evaluation

The selected wastewater treatment alternative (Alternative B) does not appear to be in conflict with any applicable water quality standards, effluent limitations, or any other technical, legislative, or legal requirements set forth by local, county, state, or federal agencies.

Based on the analysis in Section VI.A above, it appears that Alternate A will require additional permitting for stream and wetland crossings that Alternate B will not require. Alternate A will also require an NPDES Permit for Stormwater Discharges Associated with Construction Activities and will require a Highway Occupancy Permit issued by the Pennsylvania Department of Transportation for construction of the 8.7 miles of force main along and across several State roads (SR 44, 1007, I-180, 405, and I-80). While the HOP does not address water quality standards, it could have an impact on drainage.

D. Estimated Costs, Present Worth Analysis, and Other Factors

1. Construction and Project Costs

The various components of Alternatives A and B, along with their associated preliminary probable costs are presented respectively in **Tables 3 and 4**.

Table 3
Preliminary Opinion of Probable Construction and Project Costs
Alternative A - Connection to Milton Regional Sewer Authority

Item No.	Description	Quantity	Units	Unit Price	Extended Total
1	General Requirements	1	LS	\$ 226,596.00	\$ 226,596.00
2	Demolition of WWTP	1	LS	\$ 100,000.00	\$ 100,000.00
3	Erosion & Sediment Control	1	LS	\$ 20,000.00	\$ 20,000.00
4	Triplex Influent Pump Station	1	LS	\$ 994,400.00	\$ 994,400.00
5	Electrical inc. Emergency Generator	1	LS	\$ 119,000.00	\$ 119,000.00
6	8-inch DIP Force Main	46,000	LF	\$ 125.00	\$ 5,750,000.00
7	Highway Boring	450	LF	\$ 290.00	\$ 130,500.00
8	Stream Crossing	5	EA	\$ 3,180.00	\$ 15,900.00
9	State Road Restoration	16,700	SY	\$ 200.00	\$ 3,340,000.00
10	State Shoulder Restoration	17,200	SY	\$ 50.00	\$ 860,000.00
CONSTRUCTION SUBTOTAL =					\$ 11,556,396.00
10% CONSTRUCTION CONTINGENCY =					\$ 1,155,639.60
TOTAL CONSTRUCTION COST =					\$ 12,712,035.60
NON-CONSTRUCTION PROJECT COSTS (30%) =					\$ 3,813,610.68
TOTAL PROJECT COST =					\$ 16,525,646.28

Table 4
Preliminary Opinion of Probable Construction and Project Costs
Alternative B - Wastewater Treatment Plant Upgrade

Item No.	Description	Quantity	Units	Unit Price	Extended Total
1	General Requirements	1	LS	\$ 117,262.93	\$ 117,262.93
2	Demolition	1	LS	\$ 68,308.50	\$ 68,308.50
3	Erosion & Sediment Control	1	LS	\$ 10,000.00	\$ 10,000.00
4	Triplex Influent Pump Station	1	LS	\$ 199,000.00	\$ 199,000.00
5	SBR System, inc. Tank and Blowers	1	LS	\$ 1,574,000.00	\$ 1,574,000.00
6	SBR Control System	1	LS	\$ 45,000.00	\$ 45,000.00
7	Mechanical Building	1	LS	\$ 124,500.00	\$ 124,500.00
8	Ultraviolet Disinfection Building	1	LS	\$ 64,500.00	\$ 64,500.00
9	UV Units (3 total)	1	LS	\$ 117,000.00	\$ 117,000.00
10	Sludge Drying Bed Renovations	1	LS	\$ 35,000.00	\$ 35,000.00
11	Site and Yard Piping	1	LS	\$ 107,950.00	\$ 107,950.00
12	Electrical inc. Emergency Generator	1	LS	\$ 295,502.57	\$ 295,502.57
CONSTRUCTION SUBTOTAL =					\$ 2,758,024.00
10% CONSTRUCTION CONTINGENCY =					\$ 275,802.40
TOTAL CONSTRUCTION COST =					\$ 3,033,826.40
NON-CONSTRUCTION PROJECT COSTS (30%) =					\$ 910,147.92
TOTAL PROJECT COST =					\$ 3,943,974.31

Total estimated construction costs are as follows: Alternative A (Connection to MRSA) = \$12,712,036 and Alternative B (WWTP Upgrade) = \$3,033,826. Projected costs are based upon current values and do not include price escalation factors; sources for these costs included: (1) estimates provided by respective equipment manufacturer's representatives, (2) actual values from recent projects for implementing similar construction features, and (3) cost estimating procedures. Also, in the same tables are the preliminary probable project costs for these alternatives: Alternative A = \$16,525,646 and Alternative B = \$3,943,974.

2. Operation and Maintenance Costs

Preliminary projections of the operation and maintenance (O & M) costs for alternatives are presented in **Table 5**. Total annual O & M costs for Alternatives A and B are \$70,000 and \$126,300, respectively. These values include all expenditures needed to operate and maintain the wastewater treatment facility or pump station, but do not include the costs of financing capital improvements.

3. Present Worth Analysis

A present worth analysis was employed to assess the economic impact of the projected capital and O & M costs for each of the alternatives. The basic concept of this analysis is that all cash flows are converted to a common point in time, the present. As such, time value of money is considered and all future cash flows are discounted back to the present. Comparison of the equivalent worth of competing alternatives allows for prioritization of alternatives based upon economics. The basic methodology used in this study is presented in **Table 6**. When applied to Alternatives A and B, respective present worth values were projected to be \$17,579,208 and \$5,844,900 (**Table 7**). Even though Alternative B has a higher annual O & M cost, the 20-year present worth of this Alternative is significantly less than abandoning the WWTP and connecting to the Milton Regional Sewer Authority. Based upon this economic evaluation, Alternative B (WWTP Upgrade) is favored over Alternative A (Connection to MRSA).

E. Analysis of Funding Methods

Preliminary user fee projections were performed for Alternate B (WWTP Upgrade) under six different funding scenarios (**Table 8**). In five of the scenarios, PENNVEST was used as the model source of project capital, based upon the anticipated availability of a suitable funding package and a favorable assessment for PENNVEST funding by DEP. Additionally, Scenario F projects the user fee using a private bank loan to finance the capital portion of the project. The only variable in each scenario was the breakdown of funding between grant and loan amounts and loan terms. Only one scenario, Scenario E, provided a grant for the project. As evaluated, the user rate ranges from \$64.45/month (\$1M grant) to \$103.93/month (non-PENNVEST loan). Because projected user fees are speculative, every effort will be made to solicit grant moneys from any available source so that long-term debt and associated user rates can be minimized and project implementation facilitated. For example, the Commonwealth Financing Authority (CFA) is an agency for potential grant funds through various programs that are periodically open for applications. Other sources of financing that could be evaluated

Table 5
Current and Projected Operation and Maintenance Costs

Item	Description	2016 Budget	Alternative A Connection to MRSA	Alternative B WWTP Upgrade
1	Administrative Costs	\$ 21,150.00	\$ 21,150.00	\$ 21,150.00
2	Regular Maintenance Salary	\$ 23,000.00	\$ 15,000.00	\$ 15,000.00
3	Operator Salary	\$ 6,200.00	\$ -	\$ 8,000.00
4	Licensed Operator Salary	\$ 6,000.00	\$ 3,000.00	\$ 6,000.00
5	NPDES Permit Fee	\$ 600.00	\$ -	\$ 500.00
6	Materials	\$ 2,000.00	\$ 1,000.00	\$ 2,000.00
7	Chlorine & Chemicals	\$ 2,000.00	\$ -	\$ 5,000.00
8	Sludge Analysis/NPDES	\$ 8,000.00	\$ -	\$ 8,000.00
9	Utilities	\$ 14,000.00	\$ 8,000.00	\$ 15,000.00
10	Sewer Line Maint/Repair	\$ 2,600.00	\$ 2,600.00	\$ 2,600.00
11	Manhole Repair/Replace	\$ 4,500.00	\$ 4,500.00	\$ 4,500.00
12	Sewer Plant Repairs	\$ 1,500.00	\$ -	\$ 1,500.00
13	Equipment Rental	\$ 200.00	\$ 200.00	\$ 200.00
14	Building Maintenance & Repairs	\$ 200.00	\$ 100.00	\$ 200.00
15	Dues	\$ 250.00	\$ 250.00	\$ 250.00
16	Vehicles	\$ 1,600.00	\$ 1,600.00	\$ 1,600.00
17	Equipment Fund Transfers	\$ 3,600.00	\$ 3,600.00	\$ 3,600.00
18	Equipment Transfer	\$ 3,000.00	\$ 3,000.00	\$ 3,000.00
19	Insurance Premium	\$ 11,000.00	\$ 6,000.00	\$ 20,000.00
20	Sludge Disposal	\$ 8,200.00	\$ -	\$ 8,200.00
Total Annual O&M Costs =				
		\$ 119,600.00	\$ 70,000.00	\$ 126,300.00

Table 6
 Methodology Summary¹
 Economic Evaluation of Alternatives
 (Using Present-Worth Determinations)

Present Worth Cost Factors (w/ General Definitions)

- **Capital Costs** - Includes costs of construction; land, relocation, and right-of-way and easement acquisition; design, field exploration, and construction engineering; administrative and legal services; operator training and other start up services; interest during construction; and other related activities.
- **Annual Costs** - Includes annual costs of operation, maintenance, and replacement procedures that are needed to ensure effective and reliable performance of facilities during their useful life.
- **Salvage Value** - Includes values of structures, equipment, and land at the end of the useful life of the facilities. Structures and equipment are depreciated on a straight-line basis, assuming a specific market or reuse value exists, and land is considered to have a post-project useful life value at least equal to its current market value.
- **Discount Rate** - The rate established by the Water Resource Council for evaluation of water resource projects; FY2017 rate is 2.875 percent.

Present Worth Calculations

Present worth calculations were performed in accordance with the following equation:

$$P = C + [A(PWF_u)] - S$$

where P is present worth
 C is capital cost
 A is annual cost

$$PWF_u \text{ is uniform series present worth factor}^2 = \left[\frac{(1 + d)^n - 1}{d} \right] \left[\frac{1}{(1 + d)^n} \right]$$

d is discount rate³
 n is useful life in years⁴
 S is salvage value⁵

¹Presentation adapted from information provided by Pennsylvania Department of Environmental Protection.

²Uniform series present worth factor is 15.05 for all alternatives.

³FY2017 discount rate is 2.875 percent.

⁴Useful life of 20 years assumed for all facilities in this particular evaluation.

⁵Salvage value is assumed to be 0 for all alternatives.

Table 7
Present Worth of Proposed Alternatives

	Alternative	
	A Connection to MRSA	B WWTP Upgrade
Capital Cost	\$ 16,525,646.28	\$ 3,943,974.31
Annual O&M Cost	\$ 70,000.00	\$ 126,300.00
Present Worth Factor ¹	15.05	15.05
Annual O&M Present Worth	\$ 1,053,561.44	\$ 1,900,925.85
Total Present Worth	\$ 17,579,207.72	\$ 5,844,900.16

¹ Present Worth Factor = $[(1 + d)^n - 1] / [d(1 + d)^n]$
Discount Rate, d = 0.02875
n (years) = 20

FY2017 discount rate by Water Resource Council: 2.875%
Salvage Value for both alternatives is assumed to be zero.

Table 8
Projected User Rates for Alternate B: WWTP Upgrade

	Current User Rate	Scenario A PENNVEST ¹ 1.557%, 20 yrs	Scenario B PENNVEST 1.557%, 30 yrs	Scenario C PENNVEST 1.00%, 20 yrs	Scenario D PENNVEST 1.00%, 30 yrs	Scenario E PENNVEST 1.00%, 30 yrs	Scenario F Private Bank 4.00%, 20 yrs
Project Cost		\$ 3,943,974.31	\$ 3,943,974.31	\$ 3,943,974.31	\$ 3,943,974.31	\$ 3,943,974.31	\$ 3,943,974.31
Grants		\$ -	\$ -	\$ -	\$ -	\$ 1,000,000.00	\$ -
Loan Amount		\$ 3,943,974.31	\$ 3,943,974.31	\$ 3,943,974.31	\$ 3,943,974.31	\$ 2,943,974.31	\$ 3,943,974.31
Annual Debt Service (New)		\$229,625.85	\$164,640.74	\$217,657.36	\$152,224.56	\$113,627.82	\$286,796.50
Annual Debt Service (Existing)	\$ 42,751.00	\$ 42,751.00	\$ 42,751.00	\$ 42,751.00	\$ 42,751.00	\$ 42,751.00	\$ 42,751.00
Annual O&M Costs	\$ 119,600.00	\$ 126,300.00	\$ 126,300.00	\$ 126,300.00	\$ 126,300.00	\$ 126,300.00	\$ 126,300.00
Total Annual Expenses	\$ 162,351.00	\$ 398,676.85	\$ 333,691.74	\$ 386,708.36	\$ 321,275.56	\$ 282,678.82	\$ 455,847.50
Annual User Rate²	\$ 480.00	\$ 1,090.77	\$ 912.97	\$ 1,058.03	\$ 879.00	\$ 773.40	\$ 1,247.19
Monthly User Rate	\$ 40.00	\$ 90.90	\$ 76.08	\$ 88.17	\$ 73.25	\$ 64.45	\$ 103.93

¹ PENNVEST interest rate for Northumberland County: Years 1 - 5 = 1.000%, Years 6 - 30 = 1.743%, Blended Rate = 1.557%

² User Rate based on 365.5 EDUs

include a low interest loan or bond from Pennsylvania Rural Water Association (PRWA) financial services.

F. Immediate and Phased Implementation Analysis

The selected alternative involves the construction of new treatment facilities. The majority of the new tanks and buildings can be constructed while the existing treatment plant remains in service. The only phasing will be the decommissioning and demolition of the existing plant after the new plant is operational. As the new effluent limitations must be met by mid-2018, implementation of the selected alternative will be immediate.

G. Administrative Organization Evaluation

The Borough of Turbotville has the existing administrative organizations and legal authority in place to implement the recommendations of this Special Study.

VII. INSTITUTIONAL EVALUATION

A. Existing Wastewater Treatment Authority Evaluation

The Borough of Turbotville is and will continue to be the owner and operator of the existing wastewater system, including collection, conveyance, and treatment facilities. Furthermore, Turbotville is the institution through which wastewater projects will be designed, financed, constructed, owned and operated. Turbotville has the resources, including staff, certified personnel, facilities ownership, and other essentials to remain as the legal entity to provide comprehensive wastewater services for its service area. The renovated facilities of the selected alternative will be constructed on property currently owned or acquired by Turbotville. In addition, Turbotville has the ability to incur debt for construction of facilities, as the purveyor of capital projects, and the authority to set user fees and negotiate suitable agreements with other parties. The status of the Borough's current debt has been included in the analysis of the projected user fees.

B. Institutional Alternatives Needed to Implement Recommended Technical Alternative

The Borough of Turbotville has in place the administrative, financial, and operational infrastructure to proceed with the implementation of the proposed technical alternative with a high degree of confidence in the desired outcome. The Borough has been operating a wastewater treatment facility for decades and there is no need to create a new municipal authority to handle the operations of the sewer system. The Borough's structure allows it to react to future sewage facility needs.

C. Administrative and Legal Activities for Implementation of Recommended Alternative

The Borough of Turbotville will implement the recommended technical alternative through normal Borough Council procedures. All matters of a legal nature will be

addressed by the Borough solicitor. There are not any anticipated activities that are outside of the legal authority and administrative capabilities of the Borough.

The recommended technical alternative will not require the creation of an authority. The alternative will not require the development of new ordinances, regulations, or intermunicipal agreements. The recommended technical alternative will not require the acquisition of land, rights-of-way, or easements.

The recommended technical alternative (Alternative B) will not require the adoption of other municipal sewage facilities plans other than the Borough's own Special Study.

D. Institutional Alternative to Implement Recommended Technical Alternative

The Borough of Turbotville will implement the recommended technical alternative as it has the administrative and legal authority to do so effectively.

VIII. IMPLEMENTATION SCHEDULE AND JUSTIFICATION FOR SELECTED TECHNICAL AND INSTITUTIONAL ALTERNATIVES

A. Technical Alternative Justification

The technical alternative selected by the Borough of Turbotville is Alternative B: WWTP Upgrade. The upgrade will be designed around the Sequencing Batch Reactor (SBR) treatment technology. The rationale for this decision is set forth in the topical presentations below.

1. Existing Wastewater Disposal Needs
Replacement/Upgrade of the existing wastewater treatment plant with SBR technology will allow the Borough to meet its current and upcoming NPDES permit effluent limitations without the need to acquire additional land. Other treatment technologies available (ie. separate aeration basins and clarifiers) require a much larger footprint than the Borough does not have available on its current property.
2. Future Wastewater Disposal Needs
Replacement/Upgrade of the existing wastewater treatment plant with SBR technology will allow the Borough to meet its upcoming (mid-2018) NPDES permit effluent limitations without the need to acquire additional land. Other treatment technologies available (ie. separate aeration basins and clarifiers) require a much larger footprint than the Borough does not have available on its current property. The WWTP Upgrade will allow for future growth within the Borough and surrounding Township if needed.
3. Operation and Maintenance Considerations
Operational aspects of the SBR treatment technology have been proven highly reliable in hundreds of facilities in the Pennsylvania area. Biological and chemical treatment needed for both organic and nutrient (nitrogen and phosphorus) removal are consolidated in a single treatment process that has been capable of achieving the effluents limitations anticipated for the Turbotville treatment facility.

Furthermore, the overall performance capability of the SBR alternative is enhanced by automated control features that are dependable and operator friendly. In regard to maintenance, the SBR alternative will reduce the number and complexity of mechanical components, which will optimize maintenance requirements.

4. Cost-Effectiveness

The WWTP Upgrade alternative (Alternative B) is the most cost-effective of the two alternatives evaluated. **Tables 7** and **8** show the present worth analysis and impact to user fees.

5. Available Management and Administrative Systems

The Borough of Turbotville has in place the management and administrative systems necessary for successful implementation and operation of a wastewater treatment plant.

6. Available Funding Methods

PENNVEST has been chosen as the preferred agency for the acquisition of primary funding for the implementation of the WWTP Upgrade alternative. Additional funding sources will be investigated for supplemental funding.

7. Environmental Soundness and Compliance

The WWTP Upgrade alternative, along with the other alternative considered, will be in compliance with all local, county, state, and federal requirements pertinent to this type of project. Many of these compliances have been addressed within the body of this report. Though all environmental concerns would be addressed during the design and construction of either alternative, Alternative B (WWTP Upgrade) has significantly less potential for environmental impacts due to Alternative A's increased earth disturbance and stream crossings.

B. Financing Plan

The financing plan favored by the Borough for implementation of the WWTP Upgrade alternative consists of interim financing through Turbotville National Bank and primary capital financing through PENNVEST. Back-up financing could be provided by a loan through Turbotville National Bank or Pennsylvania Rural Water Association (PRWA) financial services. The entity with the most favorable loan terms at the time of application would be utilized.

C. Implementation Schedule

The proposed schedule for implementation of the WWTP Upgrade alternative is presented in **Table 9**. Please note that proposed dates are contingent upon receiving the necessary permits and approvals as anticipated; therefore, the Borough may revise the schedule if there are any associated delays in permit acquisition.

Table 9
Proposed Implementation Schedule
Alternative B: WWTP Upgrade

Milestone	Date
Receive Act 537 Study approval from the DEP	May 1, 2017 (estimate)
Submit WQM Part II Permit Application	May 5, 2017 (estimate)
Obtain WQM Part II Permit	August 2017 (estimate)
Apply for PENNVEST funding	August 2017 (TBD)
Anticipated PENNVEST offer	October 2017 (TBD)
Advertise for Bids	December 2017
Open Bids/Award Contract	February 2018
Begin Construction	March 2018
New NPDES Effluent Limits	June 1, 2018
Complete Construction	Winter 2018/2019

IX. ENVIRONMENTAL REPORT GENERATED FROM THE UER PROCESS

- A. Uniform Environmental Review Report is presented as **Appendix A**, but as an accompanying, stand-alone document

Appendix A
Environmental Report
(Included as a separate document)

Appendix B

Plan of Study



pennsylvania

DEPARTMENT OF ENVIRONMENTAL
PROTECTION

January 6, 2017

Turbotville Borough Council
Attn: Brentha Snyder, Secretary
1st Street, P.O. Box 264
Turbotville, PA 17772

Received JAN 12 2017

Re: Approval Letter - Plan of Study and Task/Activity Report
Act 537 Planning
Borough of Turbotville, Northumberland County

Dear Supervisors:

The Department of Environmental Protection (DEP) has received a Plan of Study and Task/Activity Report for preparation of an Act 537 Special Study submitted by Uni-Tec Consulting Engineers, Inc., under a cover letter dated December 21, 2016.

The special study intends to look at upgrading or replacing the existing, aging, wastewater treatment plant in order to continue to meet its permitted effluent limits. The planning area for the study will be wholly within the fenced-in confines of the existing treatment plant.

We have approved your Plan of Study for an estimated total cost of \$14,750.00. The resulting Act 537 Update Revision must be consistent with Act 537, Chapter 71, Sections 71.21 and 71.31, of DEP's regulations, and with information contained in A Guide for Preparing Act 537 Update Revisions (January 2003). In accordance with your approved Task/Activity Report, your completed planning package will be submitted to DEP for review in April 2017.

In addition to the checked items, your completed planning package must include the following:

- Part 2 – Administrative Completeness Checklist
- Part 3, subsection IV - Future Growth and Land Development - B. 5.
- Part 3, subsection VI. - Evaluation of Alternatives - E. and G.

If you have any questions or concerns, please call Amy Gresh at 570.327.3668 or email amgresh@pa.gov.

Sincerely,

Amy Gresh
Sewage Planning Specialist
Clean Water Program

cc: Northumberland County Planning Commission
Michele Aukerman
Dennis Swartzlander
Amy Gresh
File



December 21, 2016
File No. 0047-043-000

Mr. Dennis Swartzlander
Pennsylvania Department of Environmental Protection
208 West Third Street, Suite 101
Williamsport, PA 17701-6448

RE: Act 537 Special Study – Task/Activity Report
Turbotville Borough Wastewater Treatment Plant
Turbotville Borough, Northumberland County

Dear Mr. Swartzlander:

On behalf of the Borough of Turbotville, please find enclosed the proposed Task/Activity Report (TAR) for the Borough's proposed Act 537 Special Study for the Wastewater Treatment Plant. For the TAR, the following items are enclosed:

- TAR Narrative of study area and the proposed sewage planning project
- Maps of the Planning Area
- Completed Task/Activity Report form
- Part 3 (General Plan Content Checklist) of the Act 537 Plan Content and Environmental Assessment Checklist identifying the major planning elements to be included in the Special Study.

Please review the enclosed information and let us and the Borough know if this approach will satisfy the Department's requirements for an Act 537 Special Study for a potential upgrade/replacement of the Borough's wastewater treatment plant.

Should you have any questions or need additional information, please do not hesitate to contact me at (814) 238-8223, ext. 360 or by email: maa@uni-tec.com.

Sincerely,
UNI-TEC CONSULTING ENGINEERS, INC.

A handwritten signature in blue ink that reads "Michele A. Aukerman".

Michele A. Aukerman, P.E.
Project Engineer

cc: Borough of Turbotville (w/encl)

Borough of Turbotville

Wastewater Treatment Plant Upgrade

Act 537 Special Study

Task/Activity Report

Background

The Borough of Turbotville (Northumberland County) owns and operates a 0.136 million gallon per day (MGD) wastewater treatment plant that serves the residential and commercial customers of the Borough. The existing WWTP, constructed in 1988, is an activated sludge plant with coarse bubble air and dual settling basins. The WWTP has neared the end of its useful life, and at times, has struggled to meet its permitted effluent limits. Since 2009, the Borough has been exploring options to rehabilitate or replace the WWTP. Additionally, with the issuance of the renewed NPDES Permit in 2015, the Borough will be subject to more stringent effluent limitations that the existing WWTP is not capable of achieving for Ammonia, Total Phosphorus, and Total Copper. The Borough is ready to undertake a plant upgrade/replacement project with an Act 537 Special Study as the first step.

Planning Area

The planning area for the Act 537 Special Study will be the existing wastewater treatment plant site. Any proposed upgrade or replacement project will remain within the existing fenced-in confines of the treatment plant. All items included in Part 3, II of the Act 537 Plan Content and Environmental Assessment Checklist will be identified for the Planning Area. The attached map depicts the proposed Planning Area as well as the municipal boundary for the Borough of Turbotville, for reference.

Act 537 Plan Content and Checklist

In addition to identifying the Planning Area and analyzing the area's physical characteristics and environmental features, the Special Study will compare two WWTP upgrade/replacement alternatives along with a "no-action" alternative. This evaluation of the alternatives will include a determination of the most cost-effective alternative to provide long-term sewage treatment for the Borough of Turbotville.

The attached Act 537 Plan Content and Checklist and Task/Activity Report identifies the major planning elements to be included in the Borough's Act 537 Study.

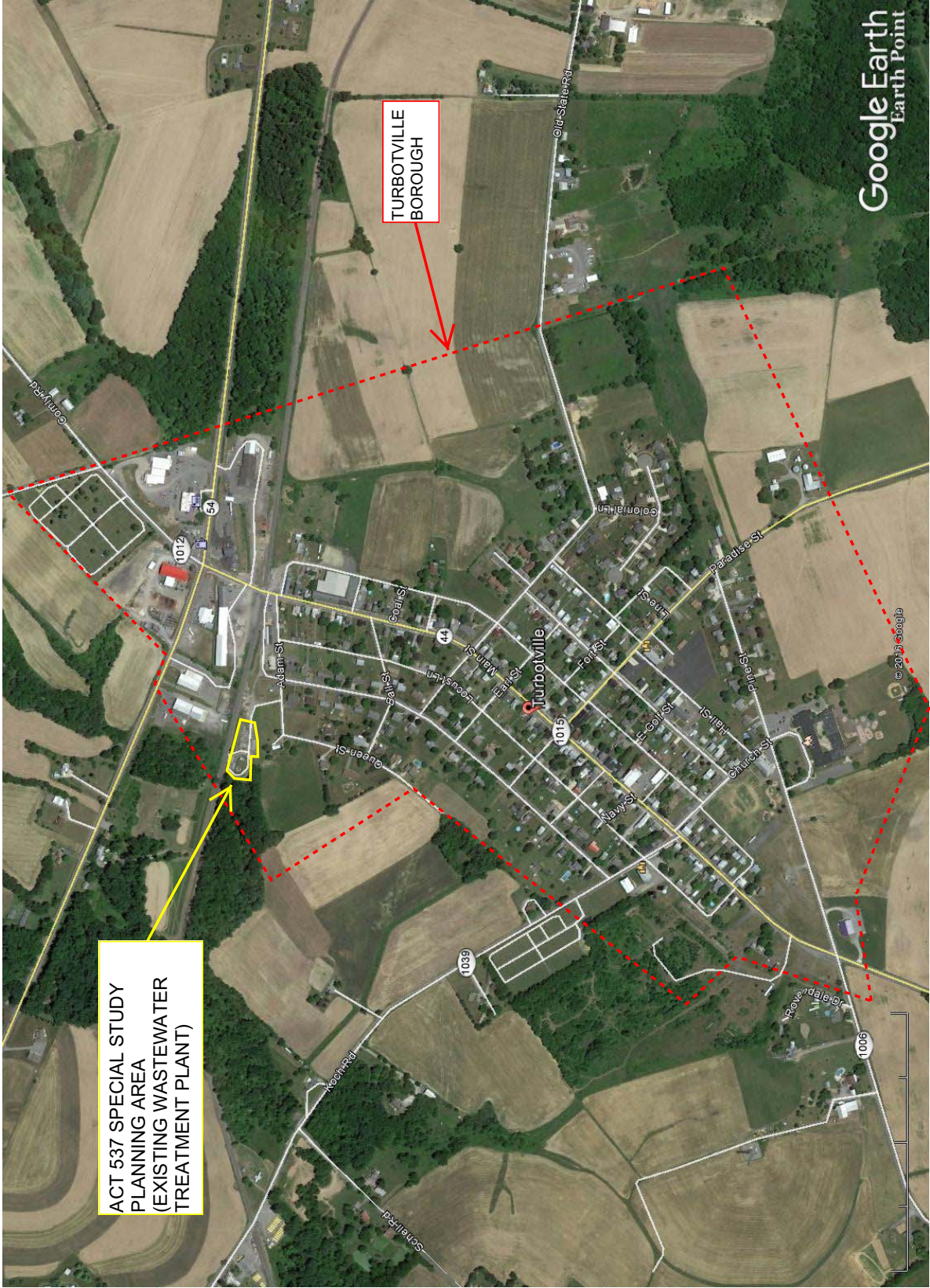

ACT 537 SPECIAL STUDY
 PLANNING AREA
 (EXISTING WASTEWATER
 TREATMENT PLANT)

TURBOTVILLE
 BOROUGH

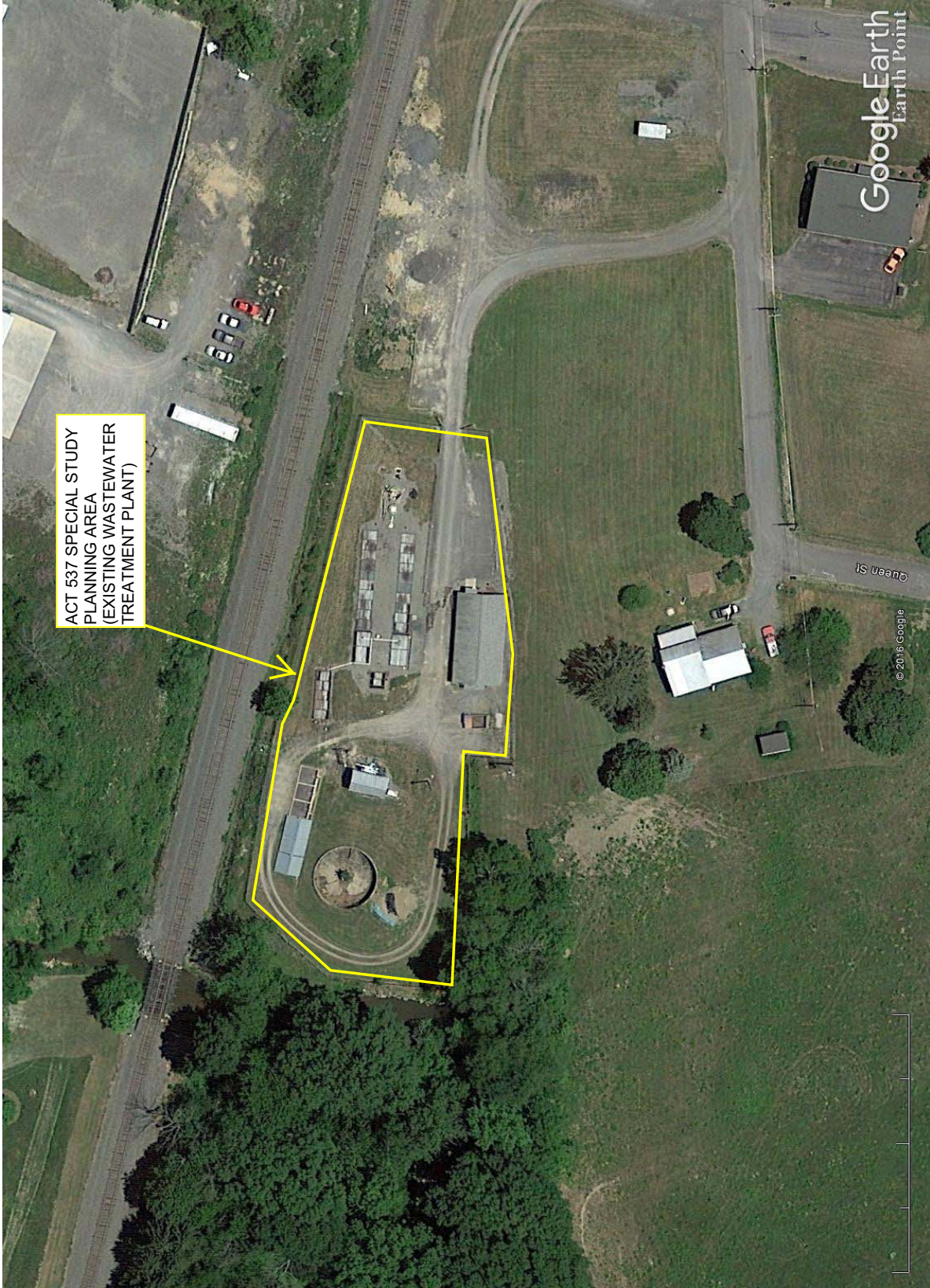

ACT 537 SPECIAL STUDY
PLANNING AREA
(EXISTING WASTEWATER
TREATMENT PLANT)

feet 600 200
meters

Google Earth

TASK/ACTIVITY REPORT

Turbotville Borough Municipality Northumberland County Wastewater Treatment Plant Proposed Planning Area (Attach Map) December 15, 2016 Date of Report

Date completed plan will be submitted to DEP April 7, 2017 Estimated Cost of Plan \$14,750.00 Sheet 1 of 2

Column Headings May Be Changed To Suit the Needs of the Planning Effort Use Additional Sheets if Necessary

TASK ACTIVITY NUMBER FROM APPENDIX I	PRINCIPAL \$135/HR		PROJECT ENG. \$125/HR		SR. ENG. N/A		ENGINEER \$80/HR		SR. CADD TECH \$90/HR		DRAFTSMAN \$80/HR		CLERICAL N/A		LEGAL N/A		SUB TOTAL
	HRS.	COST	HRS.	COST	HRS.	COST	HRS.	COST	HRS.	COST	HRS.	COST	HRS.	COST	HRS.	COST	
I A	3	\$405.00	8	\$1,000.00													\$1,405.00
II A - G			2	\$250.00			10	\$800.00	12	\$1,080.00							\$2,130.00
III A			4	\$500.00			10	\$800.00			8	\$640.00					\$1,940.00
IV A - B			2	\$250.00			10	\$800.00	10	\$900.00							\$1,950.00
V A	2	\$270.00															\$270.00
V H			2	\$250.00													\$250.00
VI A - D	3	\$405.00	32	\$4,000.00			5	\$400.00									\$4805.00
VII A - D			4	\$500.00													\$500.00

Michele A. Aukerman, P.E.
 Name of Person Completing Report

Michele A. Aukerman
 Signature

Project Engineer
 Title

Richard K. Miller
 Municipal Secretary Signature

TASK/ACTIVITY REPORT

Turbotville Borough Municipality Northumberland County Wastewater Treatment Plant Proposed Planning Area (Attach Map) December 15, 2016 Date of Report

Date completed plan will be submitted to DEP April 7, 2017 Estimated Cost of Plan \$14,750.00 Sheet 2 of 2
 Column Headings May Be Changed To Suit the Needs of the Planning Effort Use Additional Sheets if Necessary

TASK ACTIVITY NUMBER FROM APPENDIX I	PRINCIPAL		PROJECT ENG.		SR. ENG.		ENGINEER		SR. CADD TECH		DRAFTSMAN		CLERICAL		LEGAL		SUB TOTAL
	HRS.	COST	HRS.	COST	HRS.	COST	HRS.	COST	HRS.	COST	HRS.	COST	HRS.	COST	HRS.	COST	
VIII A - C			4	\$500.00	N/A												\$500.00
IX			8	\$1,000.00													\$1,000.00

Michele A. Aukerman, P.E. Name of Person Completing Report Project Engineer Title
Michelle A. Aukerman Signature Cherene K. Miller Municipal Secretary Signature

PART 3 GENERAL PLAN CONTENT CHECKLIST

DEP Use Only	Indicate Page #(s) in Plan	Item Required
_____	<u>X</u>	I. Previous Wastewater Planning
_____	<u>X</u>	A. Identify, describe and briefly analyze all past wastewater planning for its impact on the current planning effort:
_____	<u>X</u>	1. Previously undertaken under the Pennsylvania Sewage Facilities Act (Act). (Reference - Act 537, 35 P.S. §750.5(d)(1)).
_____	<u>X</u>	2. Has not been carried out according to an approved implementation schedule contained in the plans. (Reference - 25 Pa. Code §71.21(a)(5)(i)(A-D)). Section V.F of the Planning Guide.
_____	<u>X</u>	3. Is anticipated or planned by applicable sewer authorities or approved under a Chapter 94 Corrective Action Plan. (Reference - 25 Pa. Code §71.21(a)(5)(i)(A&B)). Section V.D. of the Planning Guide.
_____	<u>X</u>	4. Through planning modules for new land development, planning "exemptions" and addenda. (Reference - 25 Pa. Code §71.21(a)(5)(i)(A)).
_____	<u>X</u>	II. Physical and Demographic Analysis utilizing written description and mapping (All items listed below require maps, and all maps should show all current lots and structures and be of appropriate scale to clearly show significant information).
_____	<u>X</u>	A. Identification of planning area(s), municipal boundaries, Sewer Authority/Management Agency service area boundaries. (Reference - 25 Pa. Code §71.21(a)(1)(i)).
_____	<u>X</u>	B. Identification of physical characteristics (streams, lakes, impoundments, natural conveyance, channels, drainage basins in the planning area). (Reference - 25 Pa. Code §71.21(a)(1)(ii)).
_____	<u>X</u>	C. Soils - Analysis with description by soil type and soils mapping for areas not presently served by sanitary sewer service. Show areas suitable for in-ground onlot systems, elevated sand mounds, individual residential spray irrigation systems (IRSIS), and areas unsuitable for soil dependent systems. (Reference - 25 Pa. Code §71.21(a)(1)(iii)). Show Prime Agricultural Soils and any locally protected agricultural soils. (Reference - 25 Pa. Code §71.21(a)(1)(iii)).
_____	<u>X</u>	D. Geologic Features - (1) Identification through analysis, (2) mapping and (3) their relation to existing or potential nitrate-nitrogen pollution and drinking water sources. Include areas where existing nitrate-nitrogen levels are in excess of 5 mg/L. (Reference - 25 Pa. Code §71.21(a)(1)(iii)).
_____	<u>X</u>	E. Topography - Depict areas with slopes that are suitable for conventional systems; slopes that are suitable for elevated sand mounds and slopes that are unsuitable for onlot systems. (Reference - 25 Pa. Code §71.21(a)(1)(ii)).
_____	<u>X</u>	F. Potable Water Supplies - Identification through mapping, description and analysis. Include public water supply service areas and available public water supply capacity and aquifer yield for groundwater supplies. (Reference - 25 Pa. Code §71.21(a)(1)(vi)). Section V.C. of the Planning Guide.
_____	<u>X</u>	G. Wetlands-Identify wetlands as defined in 25 Pa. Code Chapter 105 by description, analysis and mapping. Include National Wetland Inventory mapping and potential wetland areas per the United States Department of Agricultural (USDA) Natural Resources Conservation Service (NRCS) mapped hydric soils. Proposed collection, conveyance and treatment facilities and lines must be located and labeled, along with the identified wetlands, on the map. (Reference - 25 Pa. Code §71.21(a)(1)(v)). Appendix B, Section II.I of the Planning Guide.

- | | | |
|-------|----------|--|
| <hr/> | <u>X</u> | III. Existing Sewage Facilities in the Planning Area - Identifying the Existing Needs |
| | | A. Identify, map and describe municipal and non-municipal, individual and community sewerage systems in the planning area including: |
| <hr/> | <u>X</u> | 1. Location, size and ownership of treatment facilities, main intercepting lines, pumping stations and force mains including their size, capacity, point of discharge. Also include the name of the receiving stream, drainage basin, and the facility's effluent discharge requirements. (Reference - 25 Pa. Code §71.21(a)(2)(i)(A)). |
| <hr/> | <u>X</u> | 2. A narrative and schematic diagram of the facility's basic treatment processes including the facility's National Pollutant Discharge Elimination System (NPDES) permitted capacity, and the Clean Streams Law permit number. (Reference - 25 Pa. Code §71.21(a)(2)(i)(A)). |
| <hr/> | <u>X</u> | 3. A description of problems with existing facilities (collection, conveyance and/or treatment), including existing or projected overload under 25 Pa. Code Chapter 94 (relating to municipal wasteload management) or violations of the NPDES permit, Clean Streams Law permit, or other permit, rule or regulation of DEP. (Reference - 25 Pa. Code §71.21(a)(2)(i)(B)). |
| <hr/> | <u>X</u> | 4. Details of scheduled or in-progress upgrading or expansion of treatment facilities and the anticipated completion date of the improvements. Discuss any remaining reserve capacity and the policy concerning the allocation of reserve capacity. Also discuss the compatibility of the rate of growth to existing and proposed wastewater treatment facilities. (Reference - 25 Pa. Code §71.21(a)(4)(i & ii)). |
| <hr/> | <u>X</u> | 5. A detailed description of the municipality's operation and maintenance (O & M) requirements for small flow treatment facility systems, including the status of past and present compliance with these requirements and any other requirements relating to sewage management programs (SMPs). (Reference - 25 Pa. Code §71.21(a)(2)(i)(C)). |
| <hr/> | <u>X</u> | 6. Disposal areas, if other than stream discharge, and any applicable groundwater limitations. (Reference - 25 Pa. Code §71.21(a)(4)(i & ii)). |
| <hr/> | <hr/> | B. Using DEP's publication titled <i>Act 537 Sewage Disposal Needs Identification</i> (3800-BK-DEP1949), identify, map and describe areas that utilize individual and community onlot sewage disposal and, unpermitted collection and disposal systems ("wildcat" sewers, borehole disposal, etc.) and retaining tank systems in the planning area including: |
| <hr/> | <hr/> | 1. The types of onlot systems in use. (Reference - 25 Pa. Code §71.21(a)(2)(ii)(A)). |
| <hr/> | <hr/> | 2. A sanitary survey complete with description, map and tabulation of documented and potential public health, pollution, and operational problems (including malfunctioning systems) with the systems, including violations of local ordinances, the Act, the Clean Stream Law or regulations promulgated thereunder. (Reference - 25 Pa. Code §71.21(a)(2)(ii)(B)). |
| <hr/> | <hr/> | 3. A comparison of the types of onlot sewage systems installed in an area with the types of systems which are appropriate for the area according to soil, geologic conditions, topographic limitations sewage flows, and 25 Pa. Code Chapter 73 (relating to standards for sewage disposal facilities). (Reference - 25 Pa. Code §71.21(a)(2)(ii)(C)). |
| <hr/> | <hr/> | 4. An individual water supply survey to identify possible contamination by malfunctioning onlot sewage disposal systems consistent with DEP's <i>Act 537 Sewage Disposal Needs Identification</i> publication. (Reference - 25 Pa. Code §71.21(a)(2)(ii)(B)). |

- | | | | |
|-------|----------|---|--|
| <hr/> | <hr/> | | 5. Detailed description of O & M requirements of the municipality for individual and small volume community onlot systems, including the status of past and present compliance with these requirements and any other requirements relating to SMPs. (Reference - 25 Pa. Code §71.21(a)(2)(i)(C)). |
| <hr/> | <hr/> | | C. Identify wastewater sludge and septage generation, transport and disposal methods. Include this information in the sewage facilities alternative analysis including: |
| <hr/> | <hr/> | 1. | Location of sources of wastewater sludge or septage (Septic tanks, holding tanks, wastewater treatment facilities). (Reference – 25 Pa. Code §71.71). |
| <hr/> | <hr/> | 2. | Quantities of the types of sludges or septage generated. (Reference - 25 Pa. Code §71.71). |
| <hr/> | <hr/> | 3. | Present disposal methods, locations, capacities and transportation methods. (Reference - 25 Pa. Code §71.71). |
| <hr/> | <u>X</u> | IV. Future Growth and Land Development | |
| <hr/> | | A. | Identify and briefly summarize all municipal and county planning documents adopted pursuant to the Pennsylvania Municipalities Planning Code (Act 247) including: |
| <hr/> | <u>X</u> | 1. | All land use plans and zoning maps that identify residential, commercial, industrial, agricultural, recreational and open space areas. (Reference - 25 Pa. Code §71.21(a)(3)(iv)). |
| <hr/> | <u>X</u> | 2. | Zoning or subdivision regulations that establish lot sizes predicated on sewage disposal methods. (Reference – 25 Pa. Code §71.21(a)(3)(iv)). |
| <hr/> | <u>X</u> | 3. | All limitations and plans related to floodplain and stormwater management and special protection (25 Pa. Code Chapter 93) areas. (Reference - 25 Pa. Code §71.21(a)(3)(iv)) Appendix B, Section II.F of the Planning Guide. |
| <hr/> | <u>X</u> | B. | Delineate and describe the following through map, text and analysis. |
| <hr/> | <u>X</u> | 1. | Areas with existing development or plotted subdivisions. Include the name, location, description, total number of equivalent dwelling units (EDUs) in development, total number of EDUs currently developed and total number of EDUs remaining to be developed (include time schedule for EDUs remaining to be developed). (Reference - 25 Pa. Code §71.21(a)(3)(i)). |
| <hr/> | <u>X</u> | 2. | Land use designations established under the Pennsylvania Municipalities Planning Code (35 P.S. 10101-11202), including residential, commercial and industrial areas. (Reference - 25 Pa. Code §71.21(a)(3)(ii)). Include a comparison of proposed land use as allowed by zoning and existing sewage facility planning. (Reference - 25 Pa. Code §71.21(a)(3)(iv)). |
| <hr/> | <u>X</u> | 3. | Future growth areas with population and EDU projections for these areas using historical, current and future population figures and projections of the municipality. Discuss and evaluate discrepancies between local, county, state and federal projections as they relate to sewage facilities. (Reference - 25 Pa. Code §71.21(a)(1)(iv) and (a)(3)(iii)). |
| <hr/> | <u>X</u> | 4. | Zoning, and/or subdivision regulations; local, county or regional comprehensive plans; and existing plans of any other agency relating to the development, use and protection of land and water resources with special attention to: (Reference - 25 Pa. Code §71.21(a)(3)(iv)).
--public ground/surface water supplies
--recreational water use areas
--groundwater recharge areas
--industrial water use
--wetlands |

5. Sewage planning necessary to provide adequate wastewater treatment for 5 and 10-year future planning periods based on projected growth of existing and proposed wastewater collection and treatment facilities. (Reference - 25 Pa. Code §71.21(a)(3)(v)).

V. Identify Alternatives to Provide New or Improved Wastewater Disposal Facilities

A. Conventional collection, conveyance, treatment and discharge alternatives including:

- 1. The potential for regional wastewater treatment. (Reference - 25 Pa. Code §71.21(a)(4)).
- 2. The potential for extension of existing municipal or non-municipal sewage facilities to areas in need of new or improved sewage facilities. (Reference - 25 Pa. Code §71.21(a)(4)(i)).
- 3. The potential for the continued use of existing municipal or non-municipal sewage facilities through one or more of the following: (Reference - 25 Pa. Code §71.21(a)(4)(ii)).
 - a. Repair. (Reference - 25 Pa. Code §71.21(a)(4)(ii)(A)).
 - b. Upgrading. (Reference - 25 Pa. Code §71.21(a)(4)(ii)(B)).
 - c. Reduction of hydraulic or organic loading to existing facilities. (Reference - 25 Pa. Code §71.71).
 - d. Improved O & M. (Reference - 25 Pa. Code §71.21(a)(4)(ii)(C)).
 - e. Other applicable actions that will resolve or abate the identified problems. (Reference - 25 Pa. Code §71.21(a)(4)(ii)(D)).
- 4. Repair or replacement of existing collection and conveyance system components. (Reference - 25 Pa. Code §71.21(a)(4)(ii)(A)).
- 5. The need for construction of new community sewage systems including sewer systems and/or treatment facilities. (Reference - 25 Pa. Code §71.21(a)(4)(iii)).
- 6. Use of innovative/alternative methods of collection/conveyance to serve needs areas using existing wastewater treatment facilities. (Reference - 25 Pa. Code §71.21(a)(4)(ii)(B)).

B. The use of individual sewage disposal systems including IRSIS systems based on:

- 1. Soil and slope suitability. (Reference - 25 Pa. Code §71.21(a)(2)(ii)(C)).
- 2. Preliminary hydrogeologic evaluation. (Reference - 25 Pa. Code §71.21(a)(2)(ii)(C)).
- 3. The establishment of a SMP. (Reference - 25 Pa. Code §71.21(a)(4)(iv)). See also Part "F" below.
- 4. The repair, replacement or upgrading of existing malfunctioning systems in areas suitable for onlot disposal considering: (Reference - 25 Pa. Code §71.21(a)(4)).
 - a. Existing technology and sizing requirements of 25 Pa. Code Chapter 73. (Reference - 25 Pa. Code §73.31-§73.72).
 - b. Use of expanded absorption areas or alternating absorption areas. (Reference - 25 Pa. Code §73.16).
 - c. Use of water conservation devices. (Reference - 25 Pa. Code §71.73(b)(2)(iii)).

§71.73(b)(8)).

- _____ 6. Requirements for bonding, escrow accounts, management agencies or associations to assure O & M for non-municipal facilities. (Reference - 25 Pa. Code §71.71).
- _____ G. Non-structural comprehensive planning alternatives that can be undertaken to assist in meeting existing and future sewage disposal needs including: (Reference - 25 Pa. Code §71.21(a)(4)).
 - _____ 1. Modification of existing comprehensive plans involving:
 - _____ a. Land use designations. (Reference - 25 Pa. Code §71.21(a)(4)).
 - _____ b. Densities. (Reference - 25 Pa. Code §71.21(a)(4)).
 - _____ c. Municipal ordinances and regulations. (Reference - 25 Pa. Code §71.21(a)(4)).
 - _____ d. Improved enforcement. (Reference - 25 Pa. Code §71.21(a)(4)).
 - _____ e. Protection of drinking water sources. (Reference - 25 Pa. Code §71.21(a)(4)).
 - _____ 2. Consideration of a local comprehensive plan to assist in producing sound economic and consistent land development. (Reference - 25 Pa. Code §71.21(a)(4)).
 - _____ 3. Alternatives for creating or changing municipal subdivision regulations to assure long-term use of on-site sewage disposal that consider lot sizes and protection of replacement areas. (Reference - 25 Pa. Code §71.21(a)(4)).
 - _____ 4. Evaluation of existing local agency programs and the need for technical or administrative training. (Reference - 25 Pa. Code §71.21(a)(4)).
 - _____ X H. A no-action alternative which includes discussion of both short-term and long-term impacts on: (Reference - 25 Pa. Code §71.21(a)(4)).
 - _____ X 1. Water quality/public health. (Reference - 25 Pa. Code §71.21(a)(4)).
 - _____ X 2. Growth potential (residential, commercial, industrial). (Reference - 25 Pa. Code §71.21(a)(4)).
 - _____ X 3. Community economic conditions. (Reference - 25 Pa. Code §71.21(a)(4)).
 - _____ X 4. Recreational opportunities. (Reference - 25 Pa. Code §71.21(a)(4)).
 - _____ X 5. Drinking water sources. (Reference - 25 Pa. Code §71.21(a)(4)).
 - _____ X 6. Other environmental concerns. (Reference - 25 Pa. Code §71.21(a)(4)).

VI. Evaluation of Alternatives

- _____ X A. Technically feasible alternatives identified in Section V of this checklist must be evaluated for consistency with respect to the following: (Reference - 25 Pa. Code §71.21(a)(5)(i)).
 - _____ X 1. Applicable plans developed and approved under **Sections 4 and 5 of the Clean Streams Law or Section 208 of the Clean Water Act** (33 U.S.C.A. 1288). (Reference - 25 Pa. Code §71.21(a)(5)(i)(A)). Appendix B, Section II.A of the Planning Guide.
 - _____ X 2. Municipal wasteload management **Corrective Action Plans or Annual Reports** developed under 25 Pa. Code Chapter 94. (Reference - 25 Pa. Code §71.21(a)(5)(i)(B)). The municipality's recent Wasteload Management (25 Pa. Code Chapter 94) Reports should be examined to determine if the proposed alternative is consistent with the recommendations and findings of the report. Appendix B, Section II.B of the Planning Guide.
 - _____ X 3. Plans developed under **Title II of the Clean Water Act** (33 U.S.C.A.

1281-1299) or **Titles II and VI of the Water Quality Act of 1987** (33 U.S.C.A 1251-1376). (Reference - 25 Pa. Code §71.21(a)(5)(i)(C)). Appendix B, Section II.E of the Planning Guide.

- | | | |
|-------|----------|---|
| _____ | <u>X</u> | 4. Comprehensive plans developed under the Pennsylvania Municipalities Planning Code. (Reference - 25 Pa. Code §71.21(a)(5)(i)(D)). The municipality's comprehensive plan must be examined to assure that the proposed wastewater disposal alternative is consistent with land use and all other requirements stated in the comprehensive plan. Appendix B, Section II.D of the Planning Guide. |
| _____ | <u>X</u> | 5. Antidegradation requirements as contained in 25 Pa. Code Chapters 93, 95 and 102 (relating to water quality standards, wastewater treatment requirements and erosion control) and the Clean Water Act. (Reference - 25 Pa. Code §71.21(a)(5)(i)(E). Appendix B, Section II.F of the Planning Guide. |
| _____ | <u>X</u> | 6. State Water Plans developed under the Water Resources Planning Act (42 U.S.C.A. 1962-1962 d-18). (Reference - 25 Pa. Code §71.21(a)(5)(i)(F)). Appendix B, Section II.C of the Planning Guide. |
| _____ | <u>X</u> | 7. Pennsylvania Prime Agricultural Land Policy contained in Title 4 of the Pennsylvania Code, Chapter 7, Subchapter W. Provide narrative on local municipal policy and an overlay map on prime agricultural soils. (Reference - 25 Pa. Code §71.21(a)(5)(i)(G)). Appendix B, Section II.G of the Planning Guide. |
| _____ | <u>X</u> | 8. County Stormwater Management Plans approved by DEP under the Storm Water Management Act (32 P.S. 680.1-680.17). (Reference - 25 Pa. Code §71.21(a)(5)(i)(H)). Conflicts created by the implementation of the proposed wastewater alternative and the existing recommendations for the management of stormwater in the county Stormwater Management Plan must be evaluated and mitigated. If no plan exists, no conflict exists. Appendix B, Section II.H of the Planning Guide. |
| _____ | <u>X</u> | 9. Wetland Protection. Using wetland mapping developed under Checklist Section II.G, identify and discuss mitigative measures including the need to obtain permits for any encroachments on wetlands from the construction or operation of any proposed wastewater facilities. (Reference - 25 Pa. Code §71.21(a)(5)(i)(I)) Appendix B, Section II.I of the Planning Guide. |
| _____ | <u>X</u> | 10. Protection of rare, endangered or threatened plant and animal species as identified by the Pennsylvania Natural Diversity Inventory (PNDI). (Reference - 25 Pa. Code §71.21(a)(5)(i)(J)). Provide DEP with a copy of the completed <i>PNDI Manual Project Submission Form</i> . Also provide a copy of the response letters from the 4 jurisdictional agencies regarding the findings of the PNDI search. Appendix B, Section II.J of the Planning Guide. |
| _____ | <u>X</u> | 11. Historical and archaeological resource protection under P.C.S. Title 37, Section 507 relating to cooperation by public officials with the Pennsylvania Historical and Museum Commission (PHMC). (Reference - 25 Pa. Code §71.21(a)(5)(i)(K)). Provide DEP with a completed copy of a <i>Cultural Resource Notice</i> and a return receipt for its submission to PHMC. Provide a copy of the response letter or review stamp from the Bureau of Historic Preservation (BHP) indicating the project will have no effect on, or that there may be potential impacts on, known archaeological and historical sites and any avoidance and mitigation measures required. Appendix B, Section II.K of the Planning Guide. |

- | | | |
|-----------------|-----------------|---|
| <u> </u> | <u>X</u> | B. Provide for the resolution of any inconsistencies in any of the points identified in Section VI.A. of this checklist by submitting a letter from the appropriate agency stating that the agency has received, reviewed and concurred with the resolution of identified inconsistencies. (Reference - 25 Pa. Code §71.21(a)(5)(ii). Appendix B of the Planning Guide. |
| <u> </u> | <u>X</u> | C. Evaluate alternatives identified in Section V of this checklist with respect to applicable water quality standards, effluent limitations or other technical, legislative or legal requirements. (Reference - 25 Pa. Code §71.21(a)(5)(iii)). |
| <u> </u> | <u>X</u> | D. Provide cost estimates using present worth analysis for construction, financing, ongoing administration, O & M and user fees for alternatives identified in Section V of this checklist. Estimates shall be limited to areas identified in the plan as needing improved sewage facilities within 5 years from the date of plan submission. (Reference - 25 Pa. Code §71.21(a)(5)(iv)). |
| <u> </u> | <u> </u> | E. Provide an analysis of the funding methods available to finance the proposed alternatives evaluated in Section V of this checklist. Also provide documentation to demonstrate which alternative and financing scheme combination is the most cost-effective; and a contingency financial plan to be used if the preferred method of financing cannot be implemented. The funding analysis shall be limited to areas identified in the plan as needing improved sewage facilities within 5 years from the date of the plan submission. (Reference - 25 Pa. Code §71.21(a)(5)(v)). |
| <u> </u> | <u> </u> | F. Analyze the need for immediate or phased implementation of each alternative proposed in Section V of this checklist including: (Reference - 25 Pa. Code §71.21(a)(5)(vi)). |
| <u> </u> | <u> </u> | 1. A description of any activities necessary to abate critical public health hazards pending completion of sewage facilities or implementation of SMPs. (Reference - 25 Pa. Code §71.21(a)(5)(vi)(A)). |
| <u> </u> | <u> </u> | 2. A description of the advantages, if any, in phasing construction of the facilities or implementation of a SMP justifying time schedules for each phase. (Reference - 25 Pa. Code §71.21(a)(5)(vi)(B)). |
| <u> </u> | <u> </u> | G. Evaluate administrative organizations and legal authority necessary for plan implementation. (Reference - 25 Pa. Code §71.21(a)(5)(vi)(D)). |
| <u> </u> | <u>X</u> | VII. Institutional Evaluation |
| <u> </u> | <u>X</u> | A. Provide an analysis of all existing wastewater treatment authorities, their past actions and present performance including: |
| <u> </u> | <u>X</u> | 1. Financial and debt status. (Reference - 25 Pa. Code §71.61(d)(2)). |
| <u> </u> | <u>X</u> | 2. Available staff and administrative resources. (Reference - 25 Pa. Code §71.61(d)(2)). |
| <u> </u> | <u>X</u> | 3. Existing legal authority to: |
| <u> </u> | <u>X</u> | a. Implement wastewater planning recommendations. (Reference - 25 Pa. Code §71.61(d)(2)). |
| <u> </u> | <u>X</u> | b. Implement system-wide O & M activities. (Reference - 25 Pa. Code §71.61(d)(2)). |
| <u> </u> | <u>X</u> | c. Set user fees and take purchasing actions. (Reference - 25 Pa. Code §71.61(d)(2)). |
| <u> </u> | <u>X</u> | d. Take enforcement actions against ordinance violators. (Reference - 25 Pa. Code §71.61(d)(2)). |
| <u> </u> | <u>X</u> | e. Negotiate agreements with other parties. (Reference - 25 Pa. Code §71.61(d)(2)). |

- _____ f. Raise capital for construction and O & M of facilities. (Reference - 25 Pa. Code §71.61(d)(2)).
- _____ B. Provide an analysis and description of the various institutional alternatives necessary to implement the proposed technical alternatives including:
 - _____ 1. Need for new municipal departments or municipal authorities. (Reference - 25 Pa. Code §71.61(d)(2)).
 - _____ 2. Functions of existing and proposed organizations (sewer authorities, onlot maintenance agencies, etc.). (Reference - 25 Pa. Code §71.61(d)(2)).
 - _____ 3. Cost of administration, implementability, and the capability of the authority/agency to react to future needs. (Reference - 25 Pa. Code §71.61(d)(2)).
- _____ C. Describe all necessary administrative and legal activities to be completed and adopted to ensure the implementation of the recommended alternative including:
 - _____ 1. Incorporation of authorities or agencies. (Reference - 25 Pa. Code §71.61(d)(2)).
 - _____ 2. Development of all required ordinances, regulations, standards and inter-municipal agreements. (Reference - 25 Pa. Code §71.61(d)(2)).
 - _____ 3. Description of activities to provide rights-of-way, easements and land transfers. (Reference - 25 Pa. Code §71.61(d)(2)).
 - _____ 4. Adoption of other municipal sewage facilities plans. (Reference - 25 Pa. Code §71.61(d)(2)).
 - _____ 5. Any other legal documents. (Reference - 25 Pa. Code §71.61(d)(2)).
 - _____ 6. Dates or timeframes for items 1-5 above on the project's implementation schedule.
- _____ D. Identify the proposed institutional alternative for implementing the chosen technical wastewater disposal alternative. Provide justification for choosing the specific institutional alternative considering administrative issues, organizational needs and enabling legal authority. (Reference - 25 Pa. Code §71.61(d)(2)).

VIII. Implementation Schedule and Justification for Selected Technical & Institutional Alternatives

- _____ A. Identify the technical wastewater disposal alternative which best meets the wastewater treatment needs of each study area of the municipality. Justify the choice by providing documentation which shows that it is the best alternative based on:
 - _____ 1. Existing wastewater disposal needs. (Reference - 25 Pa. Code §71.21(a)(6)).
 - _____ 2. Future wastewater disposal needs. (5 and 10 year growth areas). (Reference - 25 Pa. Code §71.21(a)(6)).
 - _____ 3. O & M considerations. (Reference - 25 Pa. Code §71.21(a)(6)).
 - _____ 4. Cost-effectiveness. (Reference - 25 Pa. Code §71.21(a)(6)).
 - _____ 5. Available management and administrative systems. (Reference - 25 Pa. Code §71.21(a)(6)).
 - _____ 6. Available financing methods. (Reference - 25 Pa. Code §71.21(a)(6)).
 - _____ 7. Environmental soundness and compliance with natural resource planning and preservation programs. (Reference - 25 Pa. Code §71.21(a)(6)).

- _____ X B. Designate and describe the capital financing plan chosen to implement the selected alternative(s). Designate and describe the chosen back-up financing plan. (Reference - 25 Pa. Code §71.21(a)(6))
- _____ X C. Designate and describe the implementation schedule for the recommended alternative, including justification for any proposed phasing of construction or implementation of a SMP. (Reference – 25 Pa. Code §71.31(d))

- _____ X **IX. Environmental Report (ER) generated from the UER Process**
- _____ X A. Complete an ER as required by the UER process and as described in the DEP Technical Guidance (381-5511-111). Include this document as “Appendix A” to the Act 537 Plan Update Revision. **Note: An ER is required only for Wastewater projects proposing funding through any of the funding sources identified in the UER.**

Appendix C
Act 537 Plan Content and Environmental
Assessment Checklist

ACT 537 PLAN CONTENT AND ENVIRONMENTAL ASSESSMENT CHECKLIST

PART 1 GENERAL INFORMATION

A. Project Information

1. Project Name Act 537 Special Study - Turbotville Wastewater Treatment Plant Alternatives

2. Brief Project Description The Special Study provides the most cost-effective solution to meet upcoming NPDES Permit Effluent Limitations that have minimal environmental and economic impact for the defined Planning Area, the existing Borough WWTP.

B. Client (Municipality) Information

Municipality Name	County	City	Boro	Twp
Turbotville	Northumberland	<input type="checkbox"/>	<input checked="" type="checkbox"/>	<input type="checkbox"/>
Municipality Contact Individual - Last Name	First Name	MI	Suffix	Title
Betz	F. Patrick			Council President
Additional Individual Last Name	First Name	MI	Suffix	Title
Miller	Diane			Secretary
Municipality Mailing Address Line 1		Mailing Address Line 2		
P.O. Box 264				
Address Last Line -- City		State	ZIP+4	
Turbotville		PA	17772	
Phone + Ext.	FAX (optional)	Email (optional)		
570-649-5476		turbotville5476@windstream.net		

C. Site Information

Site (or Project) Name	(Municipal Name) Act 537 Plan
Turbotville Wastewater Treatment Plant	
Site Location Line 1	Site Location Line 2
2 Adam Street	

D. Project Consultant Information

Last Name	First Name	MI	Suffix
Aukerman	Michele		A
Title	Consulting Firm Name		
Project Engineer	Uni-Tec Consulting Engineers, Inc.		
Mailing Address Line 1	Mailing Address Line 2		
2007 Cato Avenue			
Address Last Line -- City	State	ZIP+4	Country
State College	PA	16801	Centre
Email	Phone + Ext.	FAX	
maa@uni-tec.com	814-238-8223, ext 360	814-238-7808	

PART 2 ADMINISTRATIVE COMPLETENESS CHECKLIST

DEP Use Only	Indicate Page #(s) in Plan	In addition to the main body of the plan, the plan must include items one through eight listed below to be accepted for formal review by DEP. Incomplete plans may be denied unless the municipality is clearly requesting an advisory review.
_____	<u>i</u>	1. Table of Contents 2. Plan Summary
_____	<u>2</u>	A. Identify the proposed service areas and major problems evaluated in the plan. (Reference - 25 Pa. Code §71.21(a)(7)(i)).
_____	<u>2</u>	B. Identify the alternative(s) chosen to solve the problems and serve the areas of need identified in the plan. Also, include any institutional arrangements necessary to implement the chosen alternative(s). (Reference - 25 Pa. Code §71.21(a)(7)(ii)).
_____	<u>2</u>	C. Present the estimated cost of implementing the proposed alternative (including the user fees) and the proposed funding method to be used. (Reference - 25 Pa. Code §71.21(a)(7)(ii)).
_____	<u>2</u>	D. Identify the municipal commitments necessary to implement the Plan. (Reference - 25 Pa. Code §71.21(a)(7)(iii)).
_____	<u>3</u>	E. Provide a schedule of implementation for the project that identifies the major milestones with dates necessary to accomplish the project to the point of operational status. (Reference - 25 Pa. Code §71.21(a)(7)(iv)).
_____	_____	3. Municipal Adoption: <i>Original</i> , signed and sealed Resolution of Adoption by the municipality which contains, at a minimum, alternatives chosen and a commitment to implement the Plan in accordance with the implementation schedule. (Reference - 25 Pa. Code §71.31(f)) Section V.F. of the Planning Guide.
_____	_____	4. Planning Commission / County Health Department Comments: Evidence that the municipality has requested, reviewed and considered comments by appropriate official planning agencies of the municipality, planning agencies of the county, planning agencies with area wide jurisdiction (where applicable), and any existing county or joint county departments of health. (Reference - 25 Pa. Code §71.31(b)) Section V.E.1 of the Planning Guide.
_____	_____	5. Publication: Proof of Public Notice which documents the proposed plan adoption, plan summary, and the establishment and conduct of a 30-day comment period. (Reference - 25 Pa. Code §71.31(c)) Section V.E.2 of the Planning Guide.
_____	_____	6. Comments and Responses: Copies of <i>all</i> written comments received and municipal response to <i>each</i> comment in relation to the proposed plan. (Reference - 25 Pa. Code §71.31(c)) Section V.E.2 of the Planning Guide.
_____	<u>32</u>	7. Implementation Schedule: A complete project implementation schedule with milestone dates specific for each existing and future area of need. Other activities in the project implementation schedule should be indicated as occurring a finite number of days from a major milestone. (Reference - 25 Pa. Code §71.31(d)) Section V.F. of the Planning Guide. Include dates for the future initiation of feasibility evaluations in the project's implementation schedule for areas proposing completion of sewage facilities for planning periods in excess of five years. (Reference - 25 Pa. Code §71.21(c)).
_____	_____	8. Consistency Documentation: Documentation indicating that the appropriate agencies have received, reviewed and concurred with the method proposed to resolve identified inconsistencies within the proposed alternative and consistency requirements in 25 Pa. Code §71.21.(a)(5)(i-iii). (Reference - 25 Pa. Code §71.31(e)). Appendix B of the Planning Guide.

PART 3 GENERAL PLAN CONTENT CHECKLIST

DEP Use Only	Indicate Page #(s) in Plan	Item Required
_____	<u>5</u>	I. Previous Wastewater Planning
_____	<u>5</u>	A. Identify, describe and briefly analyze all past wastewater planning for its impact on the current planning effort:
_____	<u>5</u>	1. Previously undertaken under the Pennsylvania Sewage Facilities Act (Act). (Reference - Act 537, 35 P.S. §750.5(d)(1)).
_____	<u>6</u>	2. Has not been carried out according to an approved implementation schedule contained in the plans. (Reference - 25 Pa. Code §71.21(a)(5)(i)(A-D)). Section V.F of the Planning Guide.
_____	<u>6</u>	3. Is anticipated or planned by applicable sewer authorities or approved under a Chapter 94 Corrective Action Plan. (Reference - 25 Pa. Code §71.21(a)(5)(i)(A&B)). Section V.D. of the Planning Guide.
_____	<u>6</u>	4. Through planning modules for new land development, planning “exemptions” and addenda. (Reference - 25 Pa. Code §71.21(a)(5)(i)(A)).
_____	<u>6</u>	II. Physical and Demographic Analysis utilizing written description and mapping (All items listed below require maps, and all maps should show all current lots and structures and be of appropriate scale to clearly show significant information).
_____	<u>6</u>	A. Identification of planning area(s), municipal boundaries, Sewer Authority/Management Agency service area boundaries. (Reference – 25 Pa. Code §71.21(a)(1)(i)).
_____	<u>6</u>	B. Identification of physical characteristics (streams, lakes, impoundments, natural conveyance, channels, drainage basins in the planning area). (Reference - 25 Pa. Code §71.21(a)(1)(ii)).
_____	<u>6</u>	C. Soils - Analysis with description by soil type and soils mapping for areas not presently served by sanitary sewer service. Show areas suitable for in-ground onlot systems, elevated sand mounds, individual residential spray irrigation systems (IRSIS), and areas unsuitable for soil dependent systems. (Reference - 25 Pa. Code §71.21(a)(1)(iii)). Show Prime Agricultural Soils and any locally protected agricultural soils. (Reference - 25 Pa. Code §71.21(a)(1)(iii)).
_____	<u>7</u>	D. Geologic Features - (1) Identification through analysis, (2) mapping and (3) their relation to existing or potential nitrate-nitrogen pollution and drinking water sources. Include areas where existing nitrate-nitrogen levels are in excess of 5 mg/L. (Reference - 25 Pa. Code §71.21(a)(1)(iii)).
_____	<u>7</u>	E. Topography - Depict areas with slopes that are suitable for conventional systems; slopes that are suitable for elevated sand mounds and slopes that are unsuitable for onlot systems. (Reference - 25 Pa. Code §71.21(a)(1)(ii)).
_____	<u>7</u>	F. Potable Water Supplies - Identification through mapping, description and analysis. Include public water supply service areas and available public water supply capacity and aquifer yield for groundwater supplies. (Reference - 25 Pa. Code §71.21(a)(1)(vi)). Section V.C. of the Planning Guide.
_____	<u>8</u>	G. Wetlands-Identify wetlands as defined in 25 Pa. Code Chapter 105 by description, analysis and mapping. Include National Wetland Inventory mapping and potential wetland areas per the United States Department of Agricultural (USDA) Natural Resources Conservation Service (NRCS) mapped hydric soils. Proposed collection, conveyance and treatment facilities and lines must be located and labeled, along with the identified wetlands, on the map. (Reference - 25 Pa. Code §71.21(a)(1)(v)). Appendix B, Section II.I of the Planning Guide.

<u>8</u>		III.	Existing Sewage Facilities in the Planning Area - Identifying the Existing Needs
<u>8</u>		A.	Identify, map and describe municipal and non-municipal, individual and community sewerage systems in the planning area including:
<u>8</u>		1.	Location, size and ownership of treatment facilities, main intercepting lines, pumping stations and force mains including their size, capacity, point of discharge. Also include the name of the receiving stream, drainage basin, and the facility's effluent discharge requirements. (Reference - 25 Pa. Code §71.21(a)(2)(i)(A)).
<u>10</u>		2.	A narrative and schematic diagram of the facility's basic treatment processes including the facility's National Pollutant Discharge Elimination System (NPDES) permitted capacity, and the Clean Streams Law permit number. (Reference - 25 Pa. Code §71.21(a)(2)(i)(A)).
<u>10</u>		3.	A description of problems with existing facilities (collection, conveyance and/or treatment), including existing or projected overload under 25 Pa. Code Chapter 94 (relating to municipal wasteload management) or violations of the NPDES permit, Clean Streams Law permit, or other permit, rule or regulation of DEP. (Reference - 25 Pa. Code §71.21(a)(2)(i)(B)).
<u>11</u>		4.	Details of scheduled or in-progress upgrading or expansion of treatment facilities and the anticipated completion date of the improvements. Discuss any remaining reserve capacity and the policy concerning the allocation of reserve capacity. Also discuss the compatibility of the rate of growth to existing and proposed wastewater treatment facilities. (Reference - 25 Pa. Code §71.21(a)(4)(i & ii)).
<u>11</u>		5.	A detailed description of the municipality's operation and maintenance (O & M) requirements for small flow treatment facility systems, including the status of past and present compliance with these requirements and any other requirements relating to sewage management programs (SMPs). (Reference - 25 Pa. Code §71.21(a)(2)(i)(C)).
<u>10</u>		6.	Disposal areas, if other than stream discharge, and any applicable groundwater limitations. (Reference - 25 Pa. Code §71.21(a)(4)(i & ii)).
<u>N/A</u>		B.	Using DEP's publication titled <i>Act 537 Sewage Disposal Needs Identification</i> (3800-BK-DEP1949), identify, map and describe areas that utilize individual and community onlot sewage disposal and, unpermitted collection and disposal systems ("wildcat" sewers, borehole disposal, etc.) and retaining tank systems in the planning area including:
<u>_____</u>	<u>_____</u>	1.	The types of onlot systems in use. (Reference - 25 Pa. Code §71.21(a)(2)(ii)(A)).
<u>_____</u>	<u>_____</u>	2.	A sanitary survey complete with description, map and tabulation of documented and potential public health, pollution, and operational problems (including malfunctioning systems) with the systems, including violations of local ordinances, the Act, the Clean Stream Law or regulations promulgated thereunder. (Reference - 25 Pa. Code §71.21(a)(2)(ii)(B)).
<u>_____</u>	<u>_____</u>	3.	A comparison of the types of onlot sewage systems installed in an area with the types of systems which are appropriate for the area according to soil, geologic conditions, topographic limitations sewage flows, and 25 Pa. Code Chapter 73 (relating to standards for sewage disposal facilities). (Reference - 25 Pa. Code §71.21(a)(2)(ii)(C)).
<u>_____</u>	<u>_____</u>	4.	An individual water supply survey to identify possible contamination by malfunctioning onlot sewage disposal systems consistent with DEP's <i>Act 537 Sewage Disposal Needs Identification</i> publication. (Reference - 25 Pa. Code §71.21(a)(2)(ii)(B)).

		5. Detailed description of O & M requirements of the municipality for individual and small volume community onlot systems, including the status of past and present compliance with these requirements and any other requirements relating to SMPs. (Reference - 25 Pa. Code §71.21(a)(2)(i)(C)).
	<u>N/A</u>	C. Identify wastewater sludge and septage generation, transport and disposal methods. Include this information in the sewage facilities alternative analysis including:
		1. Location of sources of wastewater sludge or septage (Septic tanks, holding tanks, wastewater treatment facilities). (Reference – 25 Pa. Code §71.71).
		2. Quantities of the types of sludges or septage generated. (Reference - 25 Pa. Code §71.71).
		3. Present disposal methods, locations, capacities and transportation methods. (Reference - 25 Pa. Code §71.71).
	<u>11</u>	IV. Future Growth and Land Development
		A. Identify and briefly summarize all municipal and county planning documents adopted pursuant to the Pennsylvania Municipalities Planning Code (Act 247) including:
	<u>11</u>	1. All land use plans and zoning maps that identify residential, commercial, industrial, agricultural, recreational and open space areas. (Reference - 25 Pa. Code §71.21(a)(3)(iv)).
	<u>11</u>	2. Zoning or subdivision regulations that establish lot sizes predicated on sewage disposal methods. (Reference – 25 Pa. Code §71.21(a)(3)(iv)).
	<u>11</u>	3. All limitations and plans related to floodplain and stormwater management and special protection (25 Pa. Code Chapter 93) areas. (Reference - 25 Pa. Code §71.21(a)(3)(iv)) Appendix B, Section II.F of the Planning Guide.
	<u>12</u>	B. Delineate and describe the following through map, text and analysis.
	<u>12</u>	1. Areas with existing development or plotted subdivisions. Include the name, location, description, total number of equivalent dwelling units (EDUs) in development, total number of EDUs currently developed and total number of EDUs remaining to be developed (include time schedule for EDUs remaining to be developed). (Reference - 25 Pa. Code §71.21(a)(3)(i)).
	<u>12</u>	2. Land use designations established under the Pennsylvania Municipalities Planning Code (35 P.S. 10101-11202), including residential, commercial and industrial areas. (Reference - 25 Pa. Code §71.21(a)(3)(ii)). Include a comparison of proposed land use as allowed by zoning and existing sewage facility planning. (Reference - 25 Pa. Code §71.21(a)(3)(iv)).
	<u>12</u>	3. Future growth areas with population and EDU projections for these areas using historical, current and future population figures and projections of the municipality. Discuss and evaluate discrepancies between local, county, state and federal projections as they relate to sewage facilities. (Reference - 25 Pa. Code §71.21(a)(1)(iv) and (a)(3)(iii)).
	<u>13</u>	4. Zoning, and/or subdivision regulations; local, county or regional comprehensive plans; and existing plans of any other agency relating to the development, use and protection of land and water resources with special attention to: (Reference - 25 Pa. Code §71.21(a)(3)(iv)). --public ground/surface water supplies --recreational water use areas --groundwater recharge areas --industrial water use --wetlands

- | | | |
|---------------|---------------|---|
| <u> </u> | <u>13</u> | 5. Sewage planning necessary to provide adequate wastewater treatment for 5 and 10-year future planning periods based on projected growth of existing and proposed wastewater collection and treatment facilities. (Reference - 25 Pa. Code §71.21(a)(3)(v)). |
| <u> </u> | <u>13</u> | V. Identify Alternatives to Provide New or Improved Wastewater Disposal Facilities |
| <u> </u> | <u>13</u> | A. Conventional collection, conveyance, treatment and discharge alternatives including: |
| <u> </u> | <u>13</u> | 1. The potential for regional wastewater treatment. (Reference - 25 Pa. Code §71.21(a)(4)). |
| <u> </u> | <u>14</u> | 2. The potential for extension of existing municipal or non-municipal sewage facilities to areas in need of new or improved sewage facilities. (Reference - 25 Pa. Code §71.21(a)(4)(i)). |
| <u> </u> | <u>14</u> | 3. The potential for the continued use of existing municipal or non-municipal sewage facilities through one or more of the following: (Reference - 25 Pa. Code §71.21(a)(4)(ii)). |
| <u> </u> | <u>14</u> | a. Repair. (Reference - 25 Pa. Code §71.21(a)(4)(ii)(A)). |
| <u> </u> | <u>14</u> | b. Upgrading. (Reference - 25 Pa. Code §71.21(a)(4)(ii)(B)). |
| <u> </u> | <u>14</u> | c. Reduction of hydraulic or organic loading to existing facilities. (Reference - 25 Pa. Code §71.71). |
| <u> </u> | <u>14</u> | d. Improved O & M. (Reference - 25 Pa. Code §71.21(a)(4)(ii)(C)). |
| <u> </u> | <u>14</u> | e. Other applicable actions that will resolve or abate the identified problems. (Reference - 25 Pa. Code §71.21(a)(4)(ii)(D)). |
| <u> </u> | <u>16</u> | 4. Repair or replacement of existing collection and conveyance system components. (Reference - 25 Pa. Code §71.21(a)(4)(ii)(A)). |
| <u> </u> | <u>16</u> | 5. The need for construction of new community sewage systems including sewer systems and/or treatment facilities. (Reference - 25 Pa. Code §71.21(a)(4)(iii)). |
| <u> </u> | <u>17</u> | 6. Use of innovative/alternative methods of collection/conveyance to serve needs areas using existing wastewater treatment facilities. (Reference - 25 Pa. Code §71.21(a)(4)(ii)(B)). |
| <u> </u> | <u>N/A</u> | B. The use of individual sewage disposal systems including IRSIS systems based on: |
| <u> </u> | <u> </u> | 1. Soil and slope suitability. (Reference - 25 Pa. Code §71.21(a)(2)(ii)(C)). |
| <u> </u> | <u> </u> | 2. Preliminary hydrogeologic evaluation. (Reference - 25 Pa. Code §71.21(a)(2)(ii)(C)). |
| <u> </u> | <u> </u> | 3. The establishment of a SMP. (Reference - 25 Pa. Code §71.21(a)(4)(iv)). See also Part "F" below. |
| <u> </u> | <u> </u> | 4. The repair, replacement or upgrading of existing malfunctioning systems in areas suitable for onlot disposal considering: (Reference - 25 Pa. Code §71.21(a)(4)). |
| <u> </u> | <u> </u> | a. Existing technology and sizing requirements of 25 Pa. Code Chapter 73. (Reference - 25 Pa. Code §73.31-§73.72). |
| <u> </u> | <u> </u> | b. Use of expanded absorption areas or alternating absorption areas. (Reference - 25 Pa. Code §73.16). |
| <u> </u> | <u> </u> | c. Use of water conservation devices. (Reference - 25 Pa. Code §71.73(b)(2)(iii)). |

- | | | | |
|---------------|---------------|------------|---|
| <u> </u> | <u> </u> | <u>N/A</u> | C. The use of small flow sewage treatment facilities or package treatment facilities to serve individual homes or clusters of homes with consideration of: (Reference - 25 Pa. Code §71.64(d)). |
| <u> </u> | <u> </u> | | 1. Treatment and discharge requirements. (Reference - 25 Pa. Code §71.64(d)). |
| <u> </u> | <u> </u> | | 2. Soil suitability. (Reference - 25 Pa. Code §71.64(c)(1)). |
| <u> </u> | <u> </u> | | 3. Preliminary hydrogeologic evaluation. (Reference - 25 Pa. Code §71.64(c)(2)). |
| <u> </u> | <u> </u> | | 4. Municipal, Local Agency or other controls over O & M requirements through a SMP. (Reference - 25 Pa. Code §71.64(d)). See Part "F" below. |
| <u> </u> | <u> </u> | <u>N/A</u> | D. The use of community land disposal alternatives including: |
| <u> </u> | <u> </u> | | 1. Soil and site suitability. (Reference - 25 Pa. Code §71.21(a)(2)(ii)(C)). |
| <u> </u> | <u> </u> | | 2. Preliminary hydrogeologic evaluation. (Reference - 25 Pa. Code §71.21(a)(2)(ii)(C)). |
| <u> </u> | <u> </u> | | 3. Municipality, Local Agency or other controls over O & M requirements through a SMP. (Reference - 25 Pa. Code §71.21(a)(2)(ii)(C)). See Part "F" below. |
| <u> </u> | <u> </u> | | 4. The rehabilitation or replacement of existing malfunctioning community land disposal systems. (See Part "V", B, 4, a, b, c above). See also Part "F" below. |
| <u> </u> | <u> </u> | <u>N/A</u> | E. The use of retaining tank alternatives on a temporary or permanent basis including: (Reference - 25 Pa. Code §71.21(a)(4)). |
| <u> </u> | <u> </u> | | 1. Commercial, residential and industrial use. (Reference - 25 Pa. Code §71.63(e)). |
| <u> </u> | <u> </u> | | 2. Designated conveyance facilities (pumper trucks). (Reference - 25 Pa. Code §71.63(b)(2)). |
| <u> </u> | <u> </u> | | 3. Designated treatment facilities or disposal site. (Reference - 25 Pa. Code §71.63(b)(2)). |
| <u> </u> | <u> </u> | | 4. Implementation of a retaining tank ordinance by the municipality. (Reference - 25 Pa. Code §71.63(c)(3)). See Part "F" below. |
| <u> </u> | <u> </u> | | 5. Financial guarantees when retaining tanks are used as an interim sewage disposal measure. (Reference - 25 Pa. Code §71.63(c)(2)). |
| <u> </u> | <u> </u> | <u>N/A</u> | F. SMPs to assure the future O & M of existing and proposed sewage facilities through: |
| <u> </u> | <u> </u> | | 1. Municipal ownership or control over the O & M of individual onlot sewage disposal systems, small flow treatment facilities, or other traditionally non-municipal treatment facilities. (Reference - 25 Pa. Code §71.21(a)(4)(iv)). |
| <u> </u> | <u> </u> | | 2. Required inspection of sewage disposal systems on a schedule established by the municipality. (Reference - 25 Pa. Code §71.73(b)(1)). |
| <u> </u> | <u> </u> | | 3. Required maintenance of sewage disposal systems including septic and aerobic treatment tanks and other system components on a schedule established by the municipality. (Reference - 25 Pa. Code §71.73(b)(2)). |
| <u> </u> | <u> </u> | | 4. Repair, replacement or upgrading of malfunctioning onlot sewage systems. (Reference - 25 Pa. Code §71.21(a)(4)(iv) and §71.73(b)(5)) through: |
| <u> </u> | <u> </u> | | a. Aggressive pro-active enforcement of ordinances that require O & M and prohibit malfunctioning systems. (Reference - 25 Pa. Code §71.73(b)(5)). |
| <u> </u> | <u> </u> | | b. Public education programs to encourage proper O & M and repair of sewage disposal systems. |
| <u> </u> | <u> </u> | | 5. Establishment of joint municipal SMPs. (Reference - 25 Pa. Code |

- _____ §71.73(b)(8)).
- _____ 6. Requirements for bonding, escrow accounts, management agencies or associations to assure O & M for non-municipal facilities. (Reference - 25 Pa. Code §71.71).
- _____ N/A G. Non-structural comprehensive planning alternatives that can be undertaken to assist in meeting existing and future sewage disposal needs including: (Reference - 25 Pa. Code §71.21(a)(4)).
- _____ 1. Modification of existing comprehensive plans involving:
- _____ a. Land use designations. (Reference - 25 Pa. Code §71.21(a)(4)).
- _____ b. Densities. (Reference - 25 Pa. Code §71.21(a)(4)).
- _____ c. Municipal ordinances and regulations. (Reference - 25 Pa. Code §71.21(a)(4)).
- _____ d. Improved enforcement. (Reference - 25 Pa. Code §71.21(a)(4)).
- _____ e. Protection of drinking water sources. (Reference - 25 Pa. Code §71.21(a)(4)).
- _____ 2. Consideration of a local comprehensive plan to assist in producing sound economic and consistent land development. (Reference - 25 Pa. Code §71.21(a)(4)).
- _____ 3. Alternatives for creating or changing municipal subdivision regulations to assure long-term use of on-site sewage disposal that consider lot sizes and protection of replacement areas. (Reference - 25 Pa. Code §71.21(a)(4)).
- _____ 4. Evaluation of existing local agency programs and the need for technical or administrative training. (Reference - 25 Pa. Code §71.21(a)(4)).
- _____ 17 H. A no-action alternative which includes discussion of both short-term and long-term impacts on: (Reference - 25 Pa. Code §71.21(a)(4)).
- _____ 17 1. Water quality/public health. (Reference - 25 Pa. Code §71.21(a)(4)).
- _____ 17 2. Growth potential (residential, commercial, industrial). (Reference - 25 Pa. Code §71.21(a)(4)).
- _____ 17 3. Community economic conditions. (Reference - 25 Pa. Code §71.21(a)(4)).
- _____ 18 4. Recreational opportunities. (Reference - 25 Pa. Code §71.21(a)(4)).
- _____ 18 5. Drinking water sources. (Reference - 25 Pa. Code §71.21(a)(4)).
- _____ 18 6. Other environmental concerns. (Reference - 25 Pa. Code §71.21(a)(4)).
- _____ 18 **VI. Evaluation of Alternatives**
- _____ A. Technically feasible alternatives identified in Section V of this checklist must be evaluated for consistency with respect to the following: (Reference - 25 Pa. Code §71.21(a)(5)(i)).
- _____ 19 1. Applicable plans developed and approved under **Sections 4 and 5 of the Clean Streams Law or Section 208 of the Clean Water Act** (33 U.S.C.A. 1288). (Reference - 25 Pa. Code §71.21(a)(5)(i)(A)). Appendix B, Section II.A of the Planning Guide.
- _____ 19 2. Municipal wasteload management **Corrective Action Plans or Annual Reports** developed under 25 Pa. Code Chapter 94. (Reference - 25 Pa. Code §71.21(a)(5)(i)(B)). The municipality's recent Wasteload Management (25 Pa. Code Chapter 94) Reports should be examined to determine if the proposed alternative is consistent with the recommendations and findings of the report. Appendix B, Section II.B of the Planning Guide.
- _____ 19 3. Plans developed under **Title II of the Clean Water Act** (33 U.S.C.A.

1281-1299) or **Titles II and VI of the Water Quality Act of 1987** (33 U.S.C.A 1251-1376). (Reference - 25 Pa. Code §71.21(a)(5)(i)(C)). Appendix B, Section II.E of the Planning Guide.

- _____ 20 4. **Comprehensive plans** developed under the Pennsylvania Municipalities Planning Code. (Reference - 25 Pa. Code §71.21(a)(5)(i)(D)). The municipality's comprehensive plan must be examined to assure that the proposed wastewater disposal alternative is consistent with land use and all other requirements stated in the comprehensive plan. Appendix B, Section II.D of the Planning Guide.
- _____ 20 5. **Antidegradation requirements** as contained in 25 Pa. Code Chapters 93, 95 and 102 (relating to water quality standards, wastewater treatment requirements and erosion control) and the Clean Water Act. (Reference - 25 Pa. Code §71.21(a)(5)(i)(E)). Appendix B, Section II.F of the Planning Guide.
- _____ 20 6. **State Water Plans** developed under the Water Resources Planning Act (42 U.S.C.A. 1962-1962 d-18). (Reference - 25 Pa. Code §71.21(a)(5)(i)(F)). Appendix B, Section II.C of the Planning Guide.
- _____ 21 7. **Pennsylvania Prime Agricultural Land Policy** contained in Title 4 of the Pennsylvania Code, Chapter 7, Subchapter W. Provide narrative on local municipal policy and an overlay map on prime agricultural soils. (Reference - 25 Pa. Code §71.21(a)(5)(i)(G)). Appendix B, Section II.G of the Planning Guide.
- _____ 21 8. **County Stormwater Management Plans** approved by DEP under the Storm Water Management Act (32 P.S. 680.1-680.17). (Reference - 25 Pa. Code §71.21(a)(5)(i)(H)). Conflicts created by the implementation of the proposed wastewater alternative and the existing recommendations for the management of stormwater in the county Stormwater Management Plan must be evaluated and mitigated. If no plan exists, no conflict exists. Appendix B, Section II.H of the Planning Guide.
- _____ 21 9. **Wetland Protection.** Using wetland mapping developed under Checklist Section II.G, identify and discuss mitigative measures including the need to obtain permits for any encroachments on wetlands from the construction or operation of any proposed wastewater facilities. (Reference - 25 Pa. Code §71.21(a)(5)(i)(I)) Appendix B, Section II.I of the Planning Guide.
- _____ 22 10. **Protection of rare, endangered or threatened plant and animal species** as identified by the Pennsylvania Natural Diversity Inventory (PNDI). (Reference - 25 Pa. Code §71.21(a)(5)(i)(J)). Provide DEP with a copy of the completed *PNDI Manual Project Submission Form*. Also provide a copy of the response letters from the 4 jurisdictional agencies regarding the findings of the PNDI search. Appendix B, Section II.J of the Planning Guide.
- _____ 22 11. **Historical and archaeological resource protection** under P.C.S. Title 37, Section 507 relating to cooperation by public officials with the Pennsylvania Historical and Museum Commission (PHMC). (Reference - 25 Pa. Code §71.21(a)(5)(i)(K)). Provide DEP with a completed copy of a *Cultural Resource Notice* and a return receipt for its submission to PHMC. Provide a copy of the response letter or review stamp from the Bureau of Historic Preservation (BHP) indicating the project will have no effect on, or that there may be potential impacts on, known archaeological and historical sites and any avoidance and mitigation measures required. Appendix B, Section II.K of the Planning Guide.

- _____ 22 B. Provide for the resolution of any inconsistencies in any of the points identified in Section VI.A. of this checklist by submitting a letter from the appropriate agency stating that the agency has received, reviewed and concurred with the resolution of identified inconsistencies. (Reference - 25 Pa. Code §71.21(a)(5)(ii). Appendix B of the Planning Guide.
- _____ 22 C. Evaluate alternatives identified in Section V of this checklist with respect to applicable water quality standards, effluent limitations or other technical, legislative or legal requirements. (Reference - 25 Pa. Code §71.21(a)(5)(iii)).
- _____ 22-25 D. Provide cost estimates using present worth analysis for construction, financing, ongoing administration, O & M and user fees for alternatives identified in Section V of this checklist. Estimates shall be limited to areas identified in the plan as needing improved sewage facilities within 5 years from the date of plan submission. (Reference - 25 Pa. Code §71.21(a)(5)(iv)).
- _____ 25-29 E. Provide an analysis of the funding methods available to finance the proposed alternatives evaluated in Section V of this checklist. Also provide documentation to demonstrate which alternative and financing scheme combination is the most cost-effective; and a contingency financial plan to be used if the preferred method of financing cannot be implemented. The funding analysis shall be limited to areas identified in the plan as needing improved sewage facilities within 5 years from the date of the plan submission. (Reference - 25 Pa. Code §71.21(a)(5)(v)).
- _____ 30 F. Analyze the need for immediate or phased implementation of each alternative proposed in Section V of this checklist including: (Reference - 25 Pa. Code §71.21(a)(5)(vi)).
- _____ 30 1. A description of any activities necessary to abate critical public health hazards pending completion of sewage facilities or implementation of SMPs. (Reference - 25 Pa. Code §71.21(a)(5)(vi)(A)).
- _____ 30 2. A description of the advantages, if any, in phasing construction of the facilities or implementation of a SMP justifying time schedules for each phase. (Reference - 25 Pa. Code §71.21(a)(5)(vi)(B)).
- _____ 30 G. Evaluate administrative organizations and legal authority necessary for plan implementation. (Reference - 25 Pa. Code §71.21(a)(5)(vi)(D)).
- _____ 30 **VII. Institutional Evaluation**
- _____ 30 A. Provide an analysis of all existing wastewater treatment authorities, their past actions and present performance including:
- _____ 30 1. Financial and debt status. (Reference - 25 Pa. Code §71.61(d)(2)).
- _____ 30 2. Available staff and administrative resources. (Reference - 25 Pa. Code §71.61(d)(2))
- _____ 30 3. Existing legal authority to:
- _____ 30 a. Implement wastewater planning recommendations. (Reference - 25 Pa. Code §71.61(d)(2)).
- _____ 30 b. Implement system-wide O & M activities. (Reference - 25 Pa. Code §71.61(d)(2)).
- _____ 30 c. Set user fees and take purchasing actions. (Reference - 25 Pa. Code §71.61(d)(2)).
- _____ 30 d. Take enforcement actions against ordinance violators. (Reference - 25 Pa. Code §71.61(d)(2)).
- _____ 30 e. Negotiate agreements with other parties. (Reference - 25 Pa. Code §71.61(d)(2)).

_____	<u>30</u>	f. Raise capital for construction and O & M of facilities. (Reference - 25 Pa. Code §71.61(d)(2)).
_____	<u>30</u>	B. Provide an analysis and description of the various institutional alternatives necessary to implement the proposed technical alternatives including:
_____	<u>30</u>	1. Need for new municipal departments or municipal authorities. (Reference - 25 Pa. Code §71.61(d)(2)).
_____	<u>30</u>	2. Functions of existing and proposed organizations (sewer authorities, onlot maintenance agencies, etc.). (Reference - 25 Pa. Code §71.61(d)(2)).
_____	<u>30</u>	3. Cost of administration, implementability, and the capability of the authority/agency to react to future needs. (Reference - 25 Pa. Code §71.61(d)(2)).
_____	<u>30</u>	C. Describe all necessary administrative and legal activities to be completed and adopted to ensure the implementation of the recommended alternative including:
_____	<u>31</u>	1. Incorporation of authorities or agencies. (Reference - 25 Pa. Code §71.61(d)(2)).
_____	<u>31</u>	2. Development of all required ordinances, regulations, standards and inter-municipal agreements. (Reference - 25 Pa. Code §71.61(d)(2)).
_____	<u>31</u>	3. Description of activities to provide rights-of-way, easements and land transfers. (Reference - 25 Pa. Code §71.61(d)(2)).
_____	<u>31</u>	4. Adoption of other municipal sewage facilities plans. (Reference - 25 Pa. Code §71.61(d)(2)).
_____	<u>31</u>	5. Any other legal documents. (Reference - 25 Pa. Code §71.61(d)(2)).
_____	<u>N/A</u>	6. Dates or timeframes for items 1-5 above on the project's implementation schedule.
_____	<u>31</u>	D. Identify the proposed institutional alternative for implementing the chosen technical wastewater disposal alternative. Provide justification for choosing the specific institutional alternative considering administrative issues, organizational needs and enabling legal authority. (Reference - 25 Pa. Code §71.61(d)(2)).
_____	<u>31</u>	VIII. Implementation Schedule and Justification for Selected Technical & Institutional Alternatives
_____		A. Identify the technical wastewater disposal alternative which best meets the wastewater treatment needs of each study area of the municipality. Justify the choice by providing documentation which shows that it is the best alternative based on:
_____	<u>31</u>	1. Existing wastewater disposal needs. (Reference - 25 Pa. Code §71.21(a)(6)).
_____	<u>31</u>	2. Future wastewater disposal needs. (5 and 10 year growth areas). (Reference - 25 Pa. Code §71.21(a)(6)).
_____	<u>31</u>	3. O & M considerations. (Reference - 25 Pa. Code §71.21(a)(6)).
_____	<u>32</u>	4. Cost-effectiveness. (Reference - 25 Pa. Code §71.21(a)(6)).
_____	<u>32</u>	5. Available management and administrative systems. (Reference - 25 Pa. Code §71.21(a)(6)).
_____	<u>32</u>	6. Available financing methods. (Reference - 25 Pa. Code §71.21(a)(6)).
_____	<u>32</u>	7. Environmental soundness and compliance with natural resource planning and preservation programs. (Reference - 25 Pa. Code §71.21(a)(6)).

- _____ 32 B. Designate and describe the capital financing plan chosen to implement the selected alternative(s). Designate and describe the chosen back-up financing plan. (Reference - 25 Pa. Code §71.21(a)(6))
- _____ 32 C. Designate and describe the implementation schedule for the recommended alternative, including justification for any proposed phasing of construction or implementation of a SMP. (Reference – 25 Pa. Code §71.31(d))
- _____ 33 **IX. Environmental Report (ER) generated from the UER Process**
- _____ 34 A. Complete an ER as required by the UER process and as described in the DEP Technical Guidance (381-5511-111). Include this document as “Appendix A” to the Act 537 Plan Update Revision. **Note: An ER is required only for Wastewater projects proposing funding through any of the funding sources identified in the UER.**

ADDITIONAL REQUIREMENTS FOR PENNVEST PROJECTS

Municipalities that propose to implement their official sewage facilities plan updates with PENNVEST funds must meet 6 additional requirements to be eligible for such funds. See *A Guide for Preparing Act 537 Update Revisions* (362-0300-003), Appendix N for greater detail or contact the DEP regional office serving your county listed in Appendix J of the same publication.

DEP Use Only	Indicate Page #(s) in Plan	Item Required
_____	34 - <u>separate document</u>	1. Environmental Impact Assessment. (Planning Phase) The UER replaces the Environmental Impact Assessment that was a previous requirement for PENNVEST projects.
_____	<u>22-29</u>	2. Cost Effectiveness (Planning Phase) The cost-effectiveness analysis should be a present-worth (or equivalent uniform annual) cost evaluation of the principle alternatives using the interest rate that is published annually by the Water Resources Council. Normally, for PENNVEST projects the applicant should select the most cost-effective alternative based upon the above analysis. Once the alternative has been selected the user fee estimates should be developed based upon interest rates and loan terms of the selected funding method.
_____		3. Second Opinion Project Review. (Design Phase)
_____		4. Minority Business Enterprise/Women's Business Enterprise (Construction Phase)
_____		5. Civil Rights. (Construction Phase)
_____		6. Initiation of Operation/Performance Certification. (Post-construction Phase)

I/A TECHNOLOGIES

PARTIAL LISTING OF INNOVATIVE AND ALTERNATIVE TECHNOLOGIES

TREATMENT TECHNOLOGIES

Aquaculture
Aquifer Recharge
Biological Aerated Filters
Constructed Wetlands
Direct Reuse (NON-POTABLE)
Horticulture
Overland Flow
Rapid Infiltration
Silviculture
Microscreens
Controlled Release Lagoons
Swirl Concentrator

SLUDGE TREATMENT TECHNOLOGIES

Aerated Static Pile Composting
Enclosed Mechanical Composting (In vessel)
Revegetation of Disturbed Land
Aerated Windrow Composting

ENERGY RECOVERY TECHNOLOGIES

Anaerobic Digestion with more than 90 percent
Methane Recovery
Cogeneration of Electricity
Self-Sustaining Incineration

INDIVIDUAL & SYSTEM-WIDE COLLECTION TECHNOLOGIES

Cluster Systems
Septage Treatment
Small Diameter Gravity Sewers
Step Pressure Sewers
Vacuum Sewers
Variable Grade Sewers
Septic Tank Effluent Pump with
Pressure Sewers

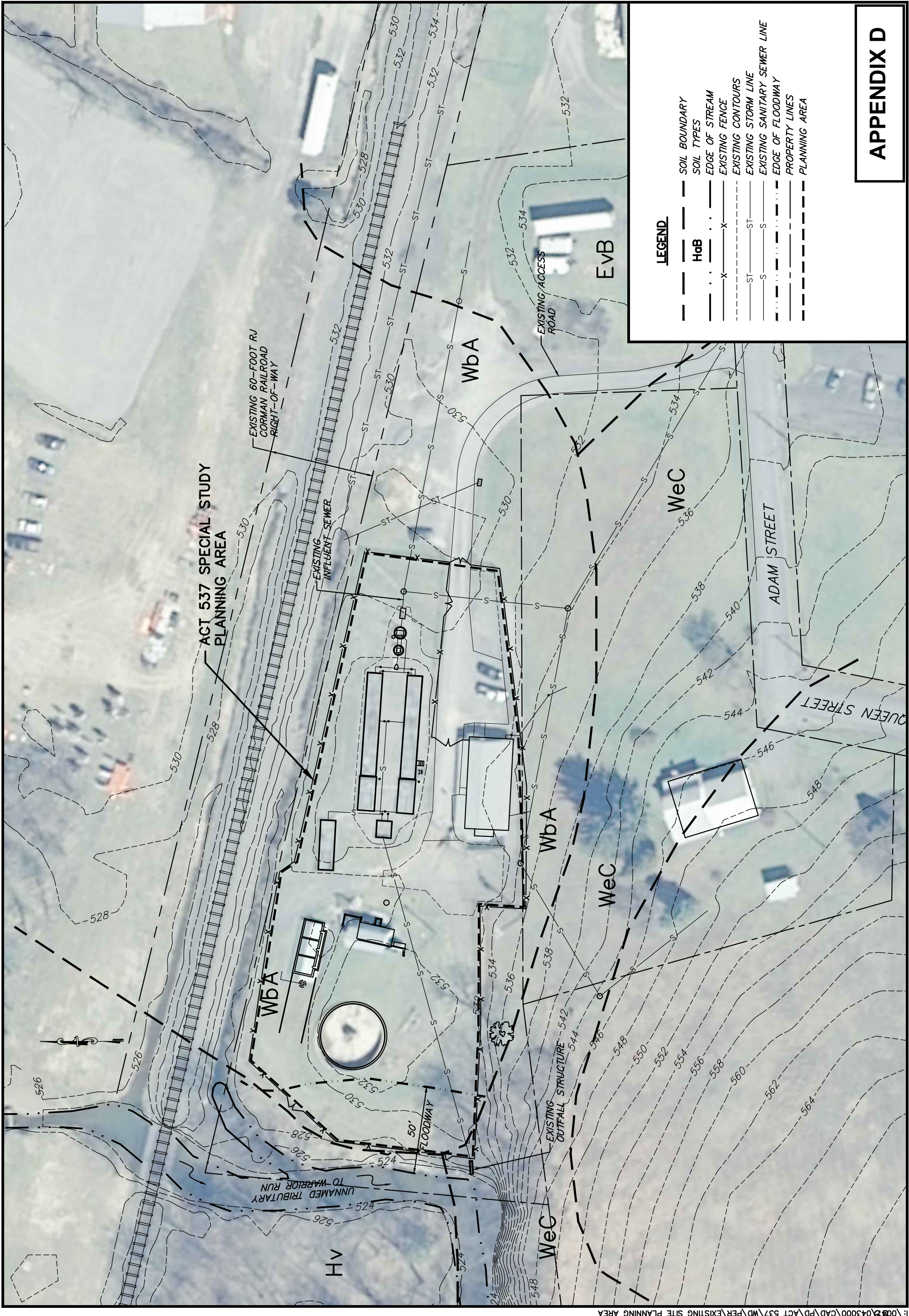

LEGEND

- SOIL BOUNDARY
- SOIL TYPES
- EDGE OF STREAM
- EXISTING FENCE
- EXISTING CONTOURS
- EXISTING STORM LINE
- EXISTING SANITARY SEWER LINE
- EDGE OF FLOODWAY
- PROPERTY LINES
- PLANNING AREA

APPENDIX D

APPENDIX E



BOROUGH OF TURBOTVILLE
NORTHUMBERLAND COUNTY
PENNSYLVANIA
WASTEWATER TREATMENT PLANT
SEWER AND WATER SERVICE AREA

SCALE
1" = 600'
PROJECT NO.
0047043101
SHEET NO.
1

UNITEC
Consulting Engineers Inc.
2007 Calo Avenue
State College, PA 16801
(814) 238-8223 www.unitec.com

DESIGNED BY: XXX
CHECKED BY: XXX
DRAWN BY: JDE
DATE: 02-20-17

REV. DESCRIPTION
DATE
VERIFY SCALES
IF NOT ONE HALF INCH
ON THIS SHEET, ADJUST
SCALE ACCORDINGLY.
BAR IS ONE HALF INCH
ON ORIGINAL DRAWING.
1/2"

Appendix F

Soil Survey

Soil Map—Northumberland County, Pennsylvania

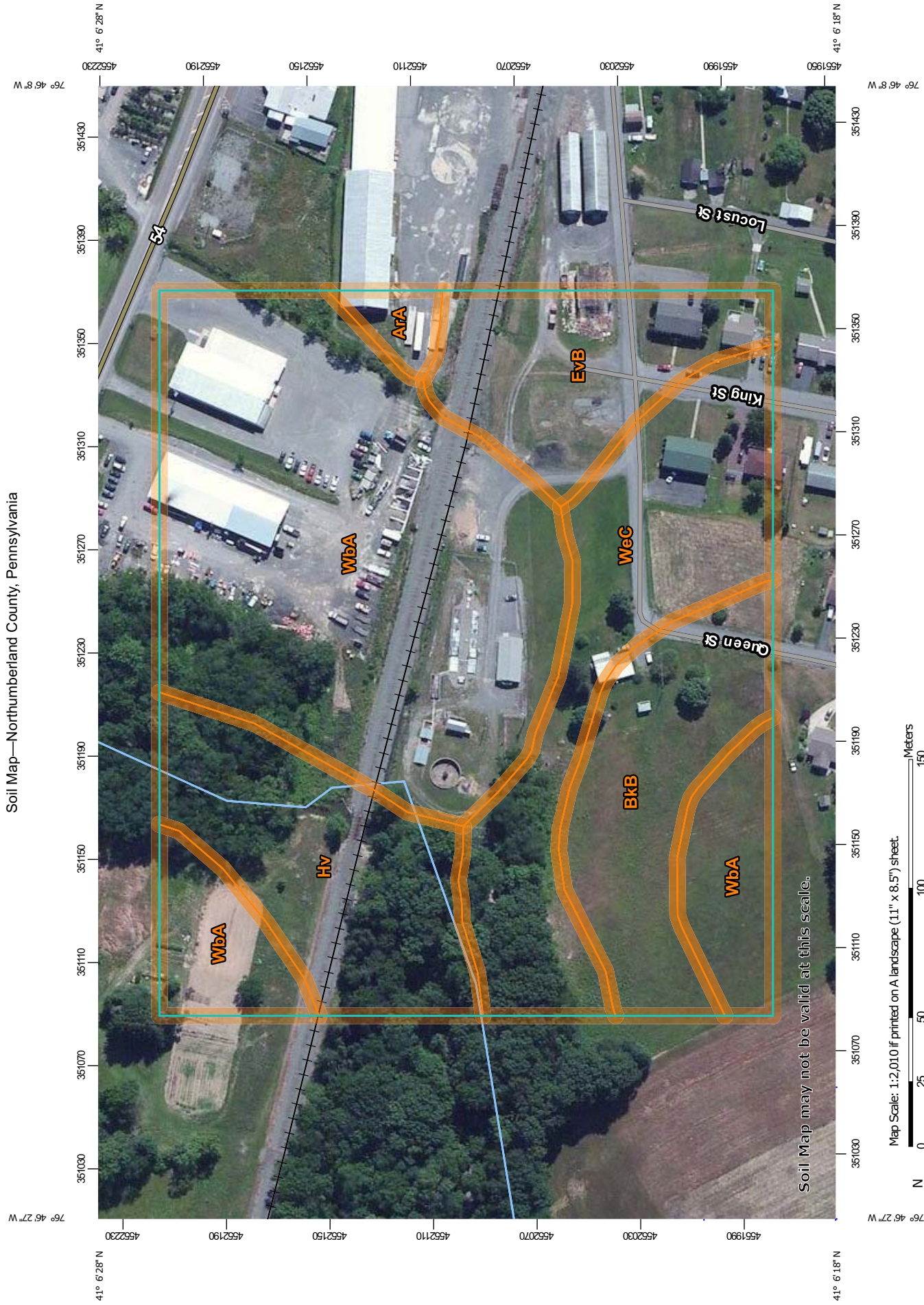





































Soil Map may not be valid at this scale.

Map Scale: 1:2,010 if printed on A landscape (11" x 8.5") sheet.

Map projection: Web Mercator Corner coordinates: WGS84 Edge tics: UTM Zone 18N WGS84

MAP LEGEND

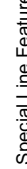
-  Area of Interest (AOI)
-  Area of Interest (AOI)
- Soils**
-  Soil Map Unit Polygons
-  Soil Map Unit Lines
-  Soil Map Unit Points
- Special Point Features**
-  Blowout
-  Borrow Pit
-  Clay Spot
-  Closed Depression
-  Gravel Pit
-  Gravelly Spot
-  Landfill
-  Lava Flow
-  Marsh or swamp
-  Mine or Quarry
-  Miscellaneous Water
-  Perennial Water
-  Rock Outcrop
-  Saline Spot
-  Sandy Spot
-  Severely Eroded Spot
-  Sinkhole
-  Slide or Slip
-  Sodic Spot
-  Spoil Area
-  Stony Spot
-  Very Stony Spot
-  Wet Spot
-  Other
-  Special Line Features
- Water Features**
-  Streams and Canals
- Transportation**
-  Rails
-  Interstate Highways
-  US Routes
-  Major Roads
-  Local Roads
- Background**
-  Aerial Photography

MAP INFORMATION

The soil surveys that comprise your AOI were mapped at 1:20,000.

Warning: Soil Map may not be valid at this scale.

Enlargement of maps beyond the scale of mapping can cause misunderstanding of the detail of mapping and accuracy of soil line placement. The maps do not show the small areas of contrasting soils that could have been shown at a more detailed scale.

Please rely on the bar scale on each map sheet for map measurements.

Source of Map: Natural Resources Conservation Service
 Web Soil Survey URL:
 Coordinate System: Web Mercator (EPSG:3857)

Maps from the Web Soil Survey are based on the Web Mercator projection, which preserves direction and shape but distorts distance and area. A projection that preserves area, such as the Albers equal-area conic projection, should be used if more accurate calculations of distance or area are required.

This product is generated from the USDA-NRCS certified data as of the version date(s) listed below.

Soil Survey Area: Northumberland County, Pennsylvania
 Survey Area Data: Version 9, Sep 19, 2016

Soil map units are labeled (as space allows) for map scales 1:50,000 or larger.

Date(s) aerial images were photographed: Apr 14, 2011—Sep 18, 2011

The orthophoto or other base map on which the soil lines were compiled and digitized probably differs from the background imagery displayed on these maps. As a result, some minor shifting of map unit boundaries may be evident.

Map Unit Legend

Northumberland County, Pennsylvania (PA097)			
Map Unit Symbol	Map Unit Name	Acres in AOI	Percent of AOI
ArA	Alvira silt loam, 0 to 3 percent slopes	0.2	1.4%
BkB	Berks channery silt loam, 3 to 8 percent slopes	1.9	11.8%
EvB	Evendale cherty silt loam, 3 to 8 percent slopes	1.7	10.2%
Hv	Holly silt loam	2.2	13.6%
WbA	Watson silt loam, 0 to 3 percent slopes	7.6	45.8%
WeC	Weikert channery silt loam, 8 to 15 percent slopes	2.9	17.4%
Totals for Area of Interest		16.5	100.0%

Appendix G

Wetlands Mapping



U.S. Fish and Wildlife Service

National Wetlands Inventory

PLANNING AREA WETLAND MAPPING



January 11, 2017

-  Estuarine and Marine Deepwater
-  Estuarine and Marine Wetland
-  Freshwater Emergent Wetland
-  Freshwater Forested/Shrub Wetland
-  Freshwater Pond
-  Lake
-  Other
-  Riverine



U.S. Fish and Wildlife Service

National Wetlands Inventory

Alternate A - Connection to MRSA



Esri, HERE, DeLorme, MapmyIndia, © OpenStreetMap contributors, and the GIS user community

This map is for general reference only. The US Fish and Wildlife Service is not responsible for the accuracy or currentness of the base data shown on this map. All wetlands related data should be used in accordance with the layer metadata found on the Wetlands Mapper web site.

February 22, 2017

- Estuarine and Marine Deepwater
- Estuarine and Marine Wetland
- Freshwater Emergent Wetland
- Freshwater Forested/Shrub Wetland
- Freshwater Pond
- Lake
- Other
- Riverine



U.S. Fish and Wildlife Service

National Wetlands Inventory

Alternate A - Wetland Crossing

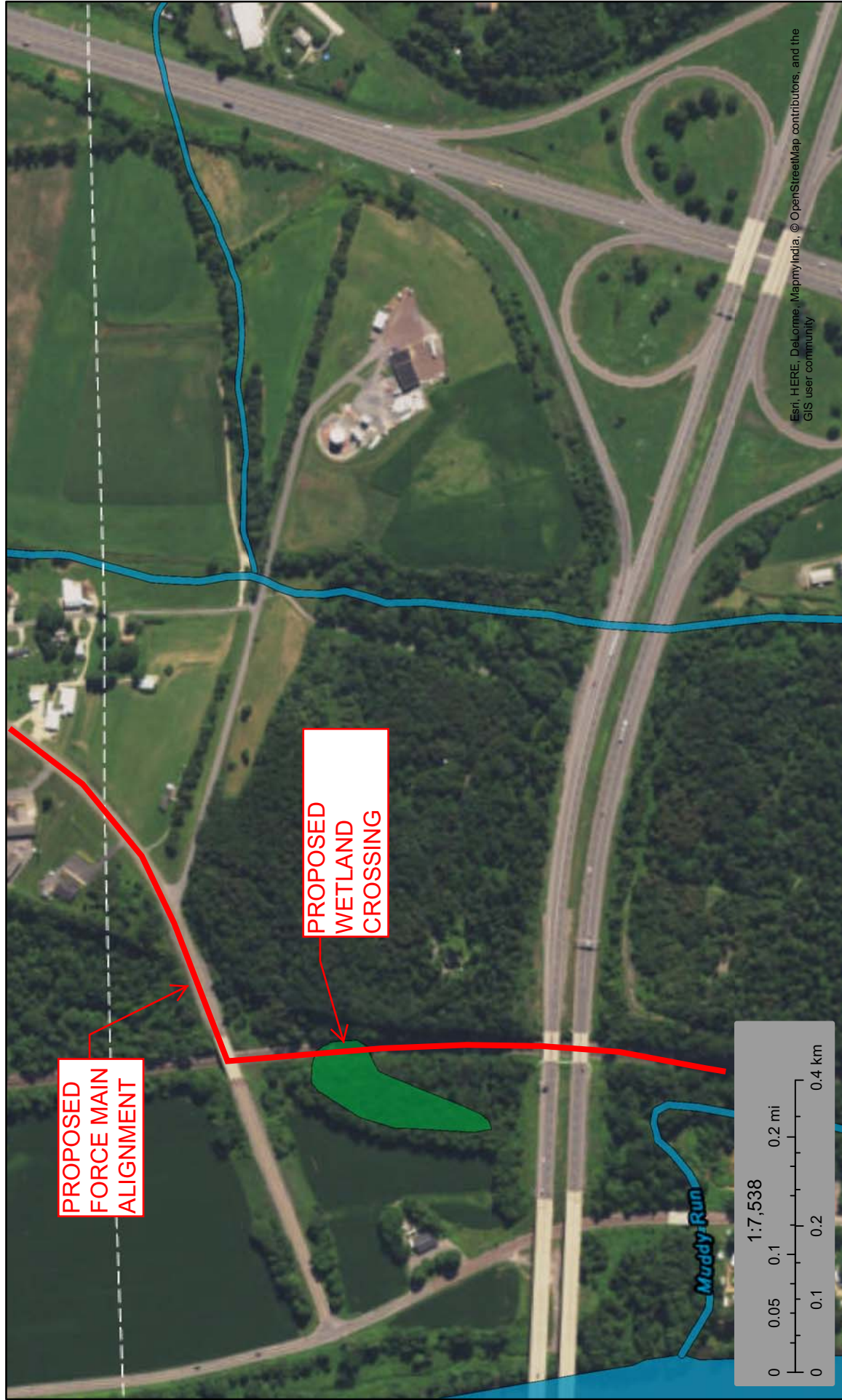

Esri, HERE, DeLorme, MapmyIndia, © OpenStreetMap contributors, and the GIS user community

This map is for general reference only. The US Fish and Wildlife Service is not responsible for the accuracy or currentness of the base data shown on this map. All wetlands related data should be used in accordance with the layer metadata found on the Wetlands Mapper web site.

February 22, 2017

- Estuarine and Marine Deepwater
- Estuarine and Marine Wetland
- Freshwater Emergent Wetland
- Freshwater Forested/Shrub Wetland
- Freshwater Pond
- Lake
- Other
- Riverine



U.S. Fish and Wildlife Service

National Wetlands Inventory

Alternate B - WWTP Upgrade

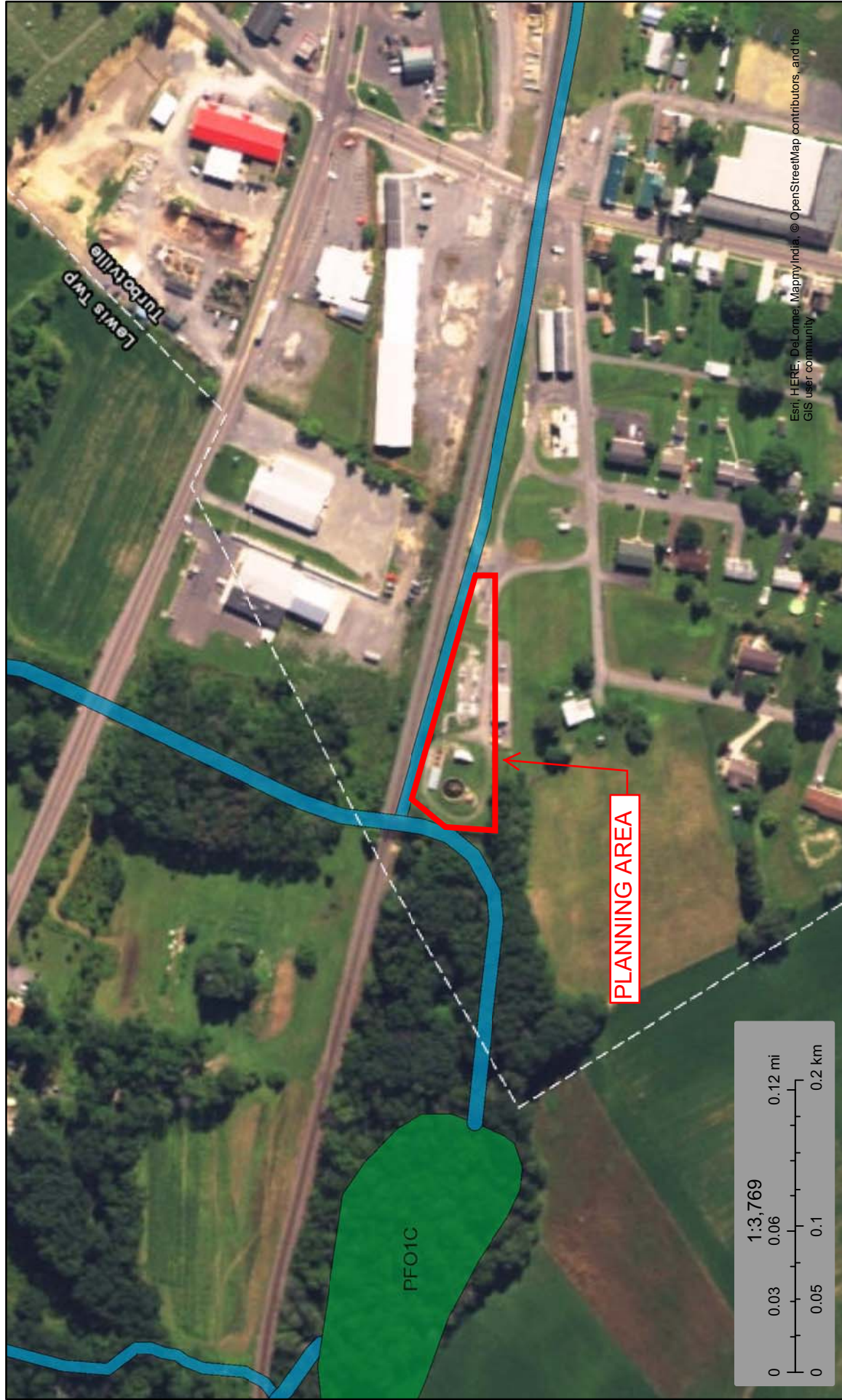

Esri, HERE, DeLorme, MapmyIndia, © OpenStreetMap contributors, and the GIS user community

This map is for general reference only. The US Fish and Wildlife Service is not responsible for the accuracy or currentness of the base data shown on this map. All wetlands related data should be used in accordance with the layer metadata found on the Wetlands Mapper web site.

February 22, 2017

- Estuarine and Marine Deepwater
- Estuarine and Marine Wetland
- Freshwater Emergent Wetland
- Freshwater Forested/Shrub Wetland
- Freshwater Pond
- Lake
- Other
- Riverine



LEGEND

- EDGE OF STREAM
- X-X- EXISTING FENCE
- - - EXISTING CONTOURS
- D-D- EXISTING DRAIN LINE
- ST-ST- EXISTING STORM LINE
- S-S- EXISTING SANITARY SEWER LINE
- UE-UE- EXISTING UNDER GROUND ELEC
- E-E- EXISTING ELECTRIC LINE

APPENDIX H

APPENDIX I

VERIFIED SCALES BAR IS ONE HALF INCH ON ORIGINAL DRAWING. IF NOT ONE HALF INCH ON THIS SHEET, ADJUST SCALE ACCORDINGLY.	DATE .	DESIGNED BY: XXX CHECKED BY: XXX DRAWN BY: JDE 02-24-17	 Consulting Engineers Inc. 2007 Cato Avenue State College, PA 16801 (814) 238-8223 www.uni-tec.com	ENGINEER'S SEAL	BOROUGH OF TURBOTVILLE NORTHUMBERLAND COUNTY PENNSYLVANIA EXISTING WASTEWATER TREATMENT PLANT SCHEMATIC DIAGRAM	SCALE: NONE PROJECT NO: 0047043101 SHEET NO: 1
	REV. DESCRIPTION .	UNITS:	UNITS:	UNITS:	UNITS:	UNITS:

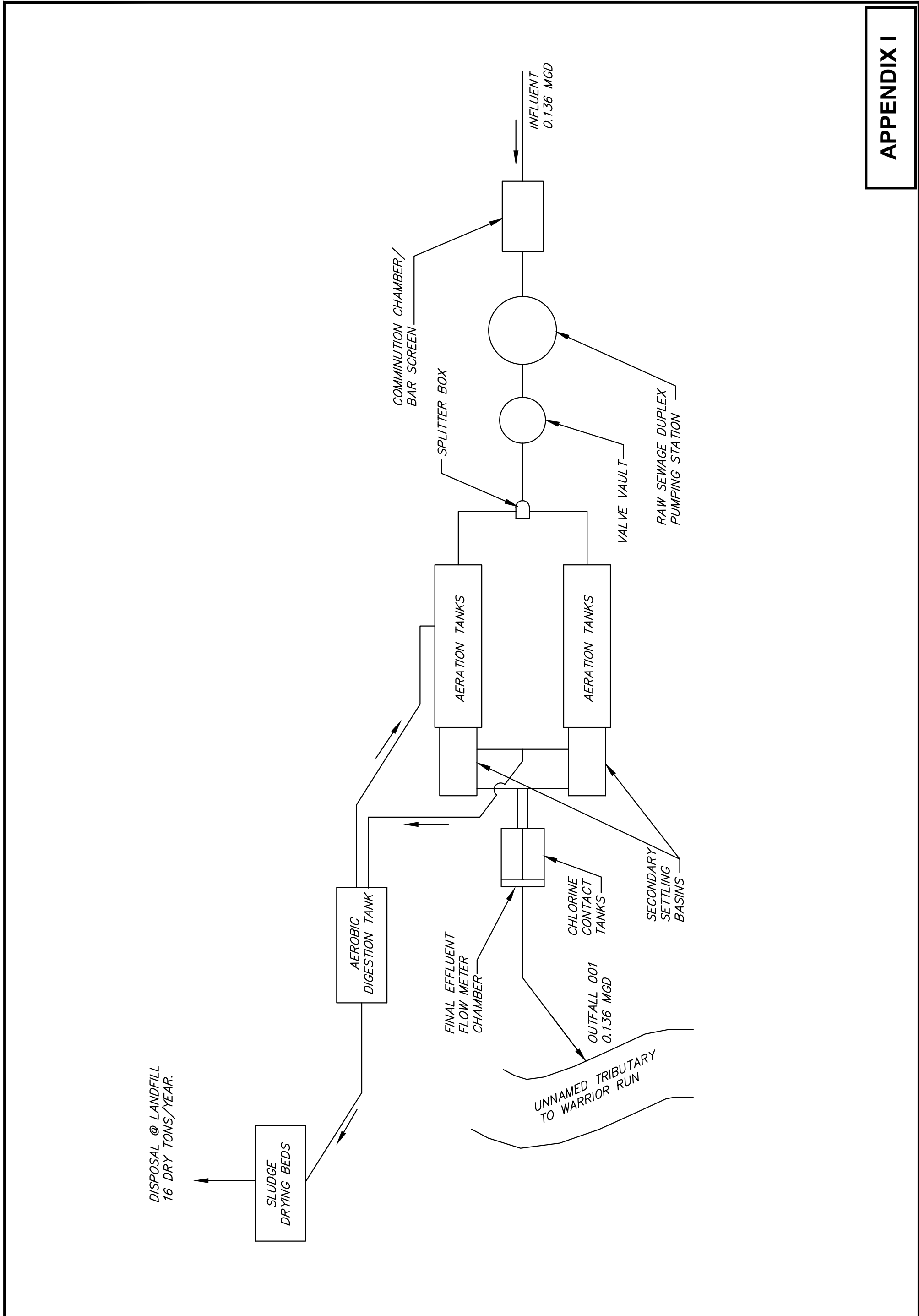

APPENDIX J - ZONING MAP

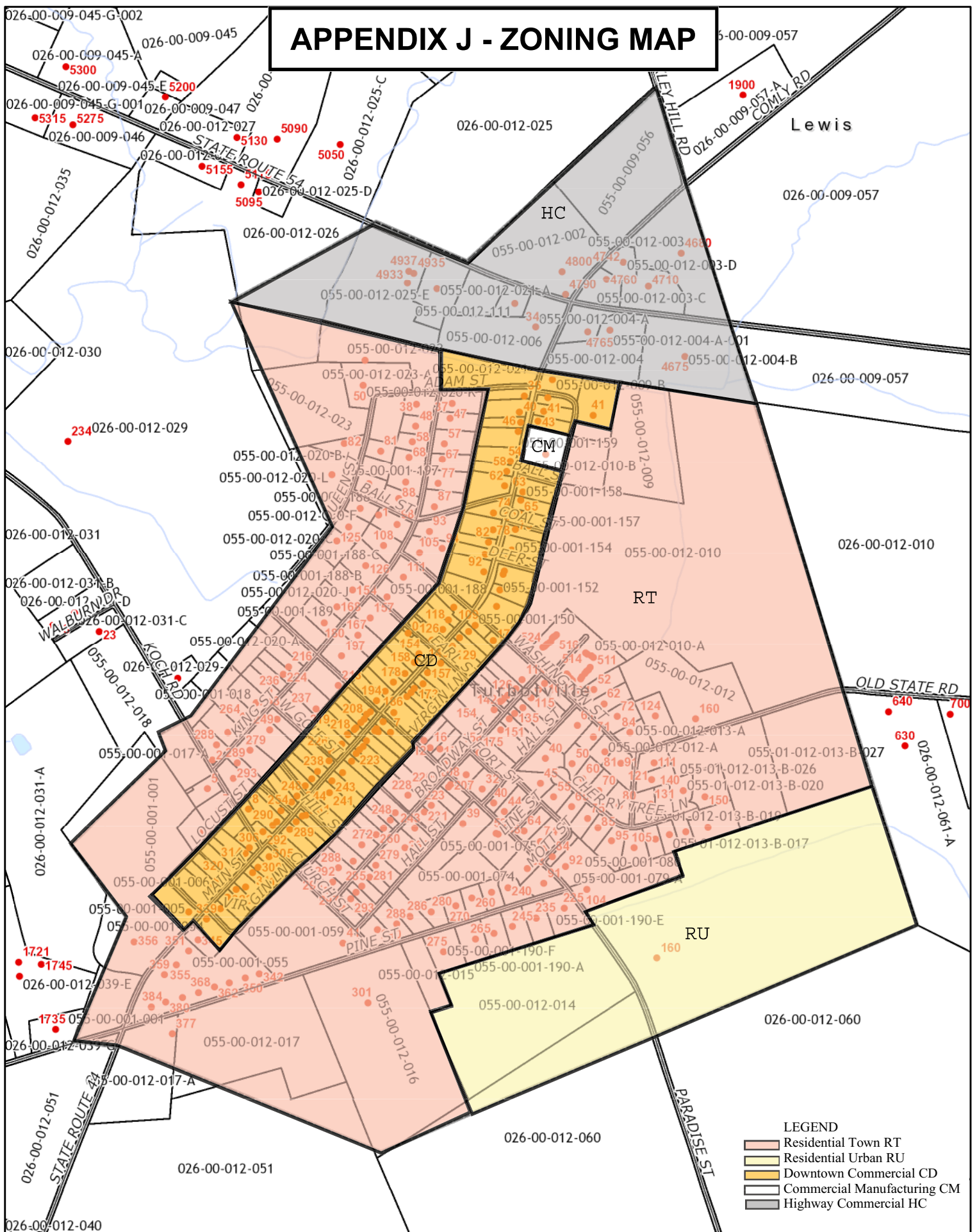

- LEGEND**
- Residential Town RT
 - Residential Urban RU
 - Downtown Commercial CD
 - Commercial Manufacturing CM
 - Highway Commercial HC

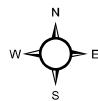

APPENDIX K

if flood insurance is available in this community, contact the National Flood Insurance Program at (800) 638-6620.



MAP SCALE 1" = 1000'



NATIONAL FLOOD INSURANCE PROGRAM

<p>PANEL 0110D</p>	<p>FIRM FLOOD INSURANCE RATE MAP NORTHUMBERLAND COUNTY, PENNSYLVANIA (ALL JURISDICTIONS)</p> <p>PANEL 110 OF 525 (SEE MAP INDEX FOR FIRM PANEL LAYOUT)</p> <table border="1" style="width: 100%; border-collapse: collapse; font-size: small;"> <thead> <tr> <th>CONTAINS:</th> <th>COMMUNITY:</th> <th>NUMBER:</th> <th>PANEL:</th> <th>SUFFIX:</th> </tr> </thead> <tbody> <tr> <td>LEWIS TOWNSHIP OF DELAWARE, TOWNSHIP OF TURBOTVILLE, BOROUGH OF</td> <td></td> <td>421840</td> <td>0110</td> <td>D</td> </tr> <tr> <td></td> <td></td> <td>421010</td> <td>0110</td> <td>D</td> </tr> <tr> <td></td> <td></td> <td>422701</td> <td>0110</td> <td>D</td> </tr> </tbody> </table>	CONTAINS:	COMMUNITY:	NUMBER:	PANEL:	SUFFIX:	LEWIS TOWNSHIP OF DELAWARE, TOWNSHIP OF TURBOTVILLE, BOROUGH OF		421840	0110	D			421010	0110	D			422701	0110	D
CONTAINS:	COMMUNITY:	NUMBER:	PANEL:	SUFFIX:																	
LEWIS TOWNSHIP OF DELAWARE, TOWNSHIP OF TURBOTVILLE, BOROUGH OF		421840	0110	D																	
		421010	0110	D																	
		422701	0110	D																	

Notice to User: The Map Number shown below should be used in order to obtain an insurance policy. The information above should be used on insurance applications for the subject community.



MAP NUMBER
42097C0110D

EFFECTIVE DATE:
JULY 16, 2008

Federal Emergency Management Agency



This is an official copy of a portion of the above referenced flood map. It was extracted using F-MIT On-Line. This map does not reflect changes or amendments which may have been made subsequent to the date on the title block. For the latest product information about National Flood Insurance Program flood maps, check the FEMA Flood Map Store at www.msc.fema.gov

Northumberland County Hazard Mitigation Plan



Turbotville Borough Flood Vulnerability

LEGEND

- Addressable Structure in SFHA
- ⚓ Church
- 🚒 Fire Department
- 🏛️ Municipal Building
- 🎓 School
- 🛣️ Interstate
- 🛣️ US Highway
- 🛣️ State Highway
- 🛣️ Local Road
- 🚂 Railroad
- 🌊 Stream / River
- 🏘️ Municipality
- 🗺️ County

Special Flood Hazard Area (SFHA)

- 🌊 Approximate 1% Annual-Chance-Flood
- 🟡 Detailed 1% Annual-Chance-Flood

Source: ESRI; Northumberland County GIS Dept., 2011.
Flood data obtained from FEMA's DFIRM database.
Effective DFIRM Date: 7/16/2008

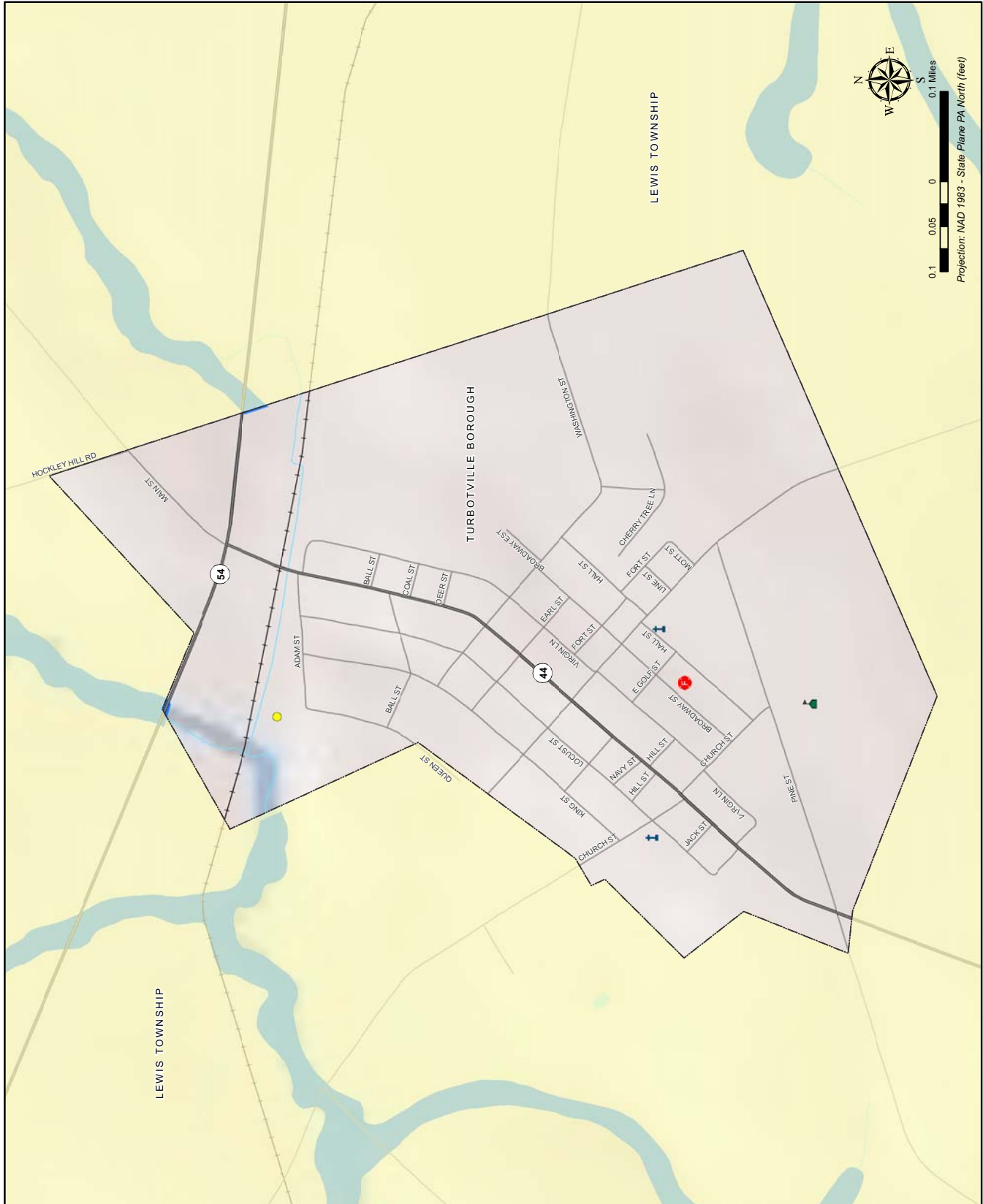
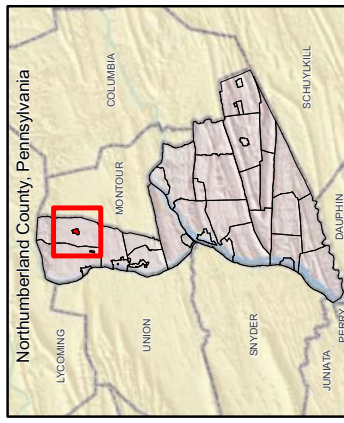

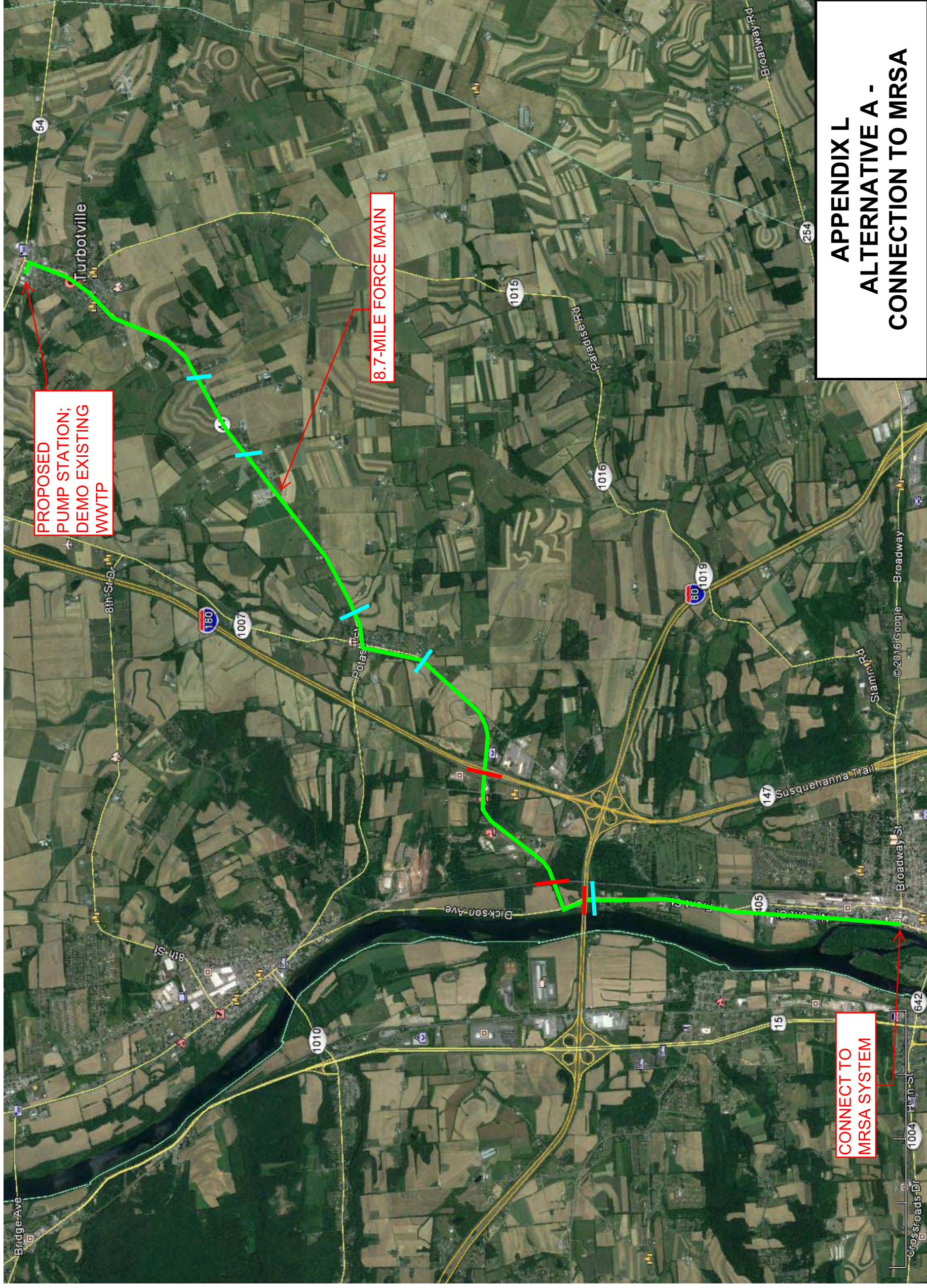

Highway or
RR Crossing

Stream
Crossing

PROPOSED
PUMP STATION;
DEMO EXISTING
WWTP

8.7-MILE FORCE MAIN

CONNECT TO
MRSA SYSTEM

**APPENDIX L
ALTERNATIVE A -
CONNECTION TO MRSA**



Phases of Operation

The AquaSBR sequencing batch reactor system features time-managed operation and control of aerobic, anoxic and anaerobic processes within each reactor including equalization and clarification. The AquaSBR system utilizes five basic phases of operation to meet advanced wastewater treatment objectives. The duration of any particular phase may be based upon specific waste characteristics and/or effluent objectives.

Figure 2
Phases of Operation for SBR w/ BNR Capability
Process Technology by Aqua-Aerobic Systems, Inc.

① Mix-Fill



- Influent flow enters the reactor
- Mixing is initiated with the AquadD Mixer to achieve complete mix of the reactor contents in the absence of aeration
- Anoxic conditions are created which facilitate removal of any residual nitrite/nitrate (NO_x) via the process of denitrification
- In systems requiring phosphorus removal, the Mix-Fill phase is extended to create anaerobic conditions where phosphorus accumulating organisms (PAO) release phosphorus then ready for subsequent luxury uptake during aeration times
- Anoxic conditions assist in the control of some types of filamentous organisms

② React-Fill



- Influent flow continues under mixed and aerated conditions
- Intermittent aeration may promote aerobic or anoxic conditions
- Biological/chemical oxygen demand (BOD/COD) and ammonia nitrogen (NH_3) are reduced under aerated conditions
- Luxury uptake of phosphorus is produced under aerated conditions
- NO_x is reduced under anoxic conditions
- Separation of aeration and mixing allows the aeration source to be turned down during low flow conditions to conserve energy while the system's flexibility allows nitrification/denitrification to be easily managed

③ React



- Influent flow is terminated creating true batch conditions
- Mixing and aeration continue in the absence of influent flow
- Biological/chemical oxygen demand (BOD/COD) and ammonia nitrogen (NH_3) reduction continue under aerated conditions
- Oxygen can be delivered on a "as needed" basis via dissolved oxygen probes while maintaining completely mixed conditions
- Provides final treatment prior to settling to meet targeted effluent objectives

④ Settle



- Influent flow does not enter the reactor
- Mixing and aeration are terminated
- Ideal solids/liquid separation is achieved due to perfectly quiescent conditions
- Adjustable time values allow settling time to match prevailing process conditions

⑤ Decant/Sludge Waste



- Influent flow does not enter the reactor
- Mixing and aeration remain off
- Decantable volume is removed by subsurface withdrawal
- Floating decanter follows the liquid level, maximizing distance between the withdrawal point and the sludge blanket
- Small amount of sludge is wasted near the end of each cycle

APPENDIX N

SCALE
1" = 50'
PROJECT NO.
0047043101
SHEET NO.
1

BOROUGH OF TURBOTVILLE
NORTHUMBERLAND COUNTY
PENNSYLVANIA
WASTEWATER TREATMENT PLANT
PROPOSED SITE PLAN

ENGINEERS SEAL



2007 Calo Avenue
State College, PA 16801
(814) 238-8223 www.uni-tec.com
DESIGNED BY: XXX
CHECKED BY: XXX
DRAWN BY: JDE
DATE: 02-20-17

REV. DESCRIPTION

DATE

VERIFY SCALES
IF NOT ONE HALF INCH
ON THIS SHEET, ADJUST
SCALE ACCORDINGLY.
BAR IS ONE HALF INCH
ON ORIGINAL DRAWING.
1/2"

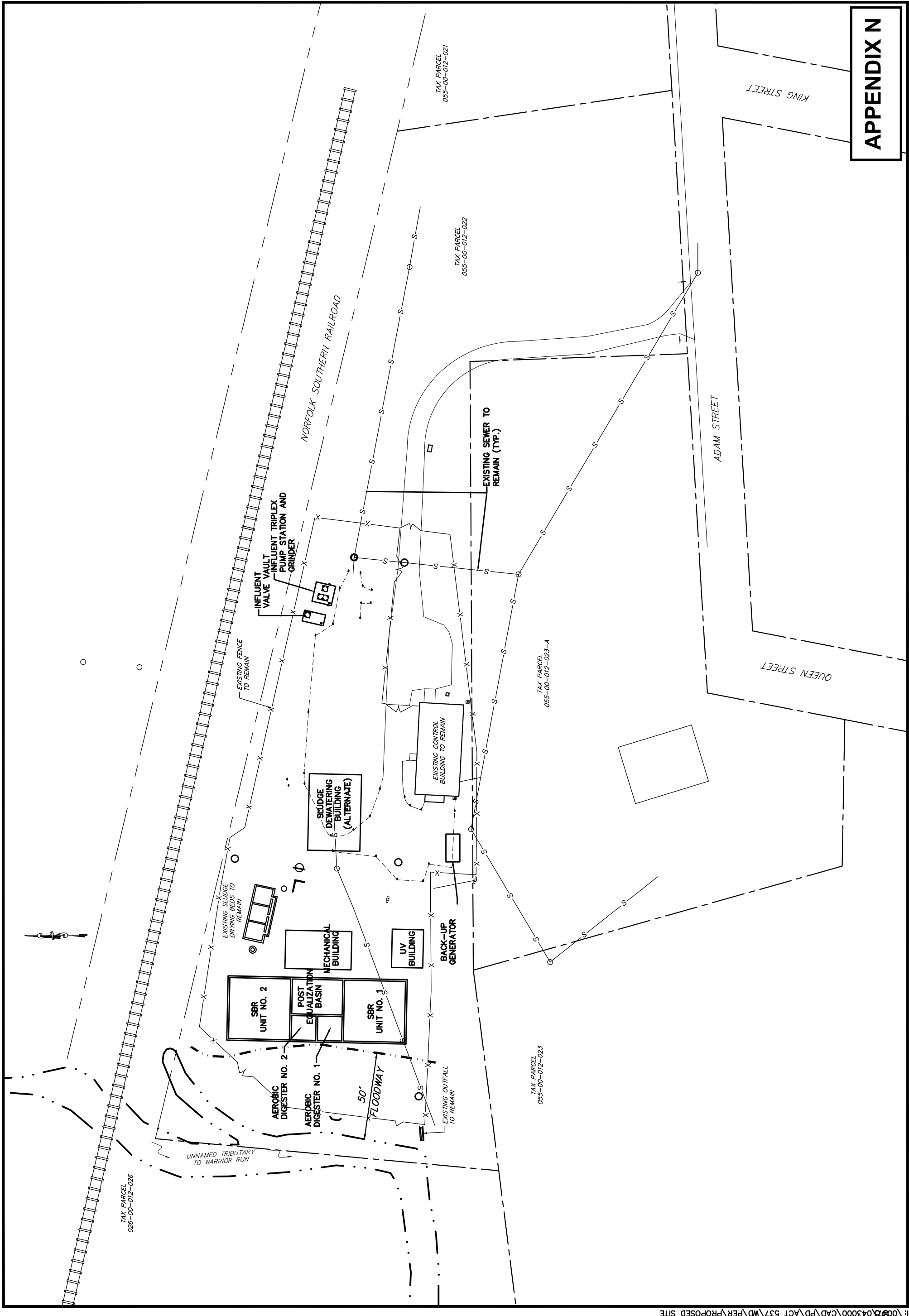

Appendix O
Pennsylvania Natural Diversity Inventory
(PNDI) Receipt

1. PROJECT INFORMATION

Project Name: **Act 537 Special Study Wastewater Treatment Plant Upgrade**

Date of Review: **1/11/2017 10:46:58 AM**

Project Category: **Waste Transfer, Treatment, and Disposal, Liquid waste/Effluent, Sewage module/Act 537 plan**

Project Area: **0.90 acres**

County(s): **Northumberland**

Township/Municipality(s): **TURBOTVILLE**

ZIP Code: **17772**

Quadrangle Name(s): **MILTON**

Watersheds HUC 8: **Lower West Branch Susquehanna**

Watersheds HUC 12: **Warrior Run**

Decimal Degrees: **41.106490, -76.771729**

Degrees Minutes Seconds: **41° 6' 23.3626" N, 76° 46' 18.2242" W**

2. SEARCH RESULTS

Agency	Results	Response
PA Game Commission	No Known Impact	No Further Review Required
PA Department of Conservation and Natural Resources	No Known Impact	No Further Review Required
PA Fish and Boat Commission	No Known Impact	No Further Review Required
U.S. Fish and Wildlife Service	No Known Impact	No Further Review Required

As summarized above, Pennsylvania Natural Diversity Inventory (PNDI) records indicate no known impacts to threatened and endangered species and/or special concern species and resources within the project area. Therefore, based on the information you provided, no further coordination is required with the jurisdictional agencies. This response does not reflect potential agency concerns regarding impacts to other ecological resources, such as wetlands.

Act 537 Special Study Wastewater Treatment Plant Upgrade



- Project Boundary
- Buffered Project Boundary

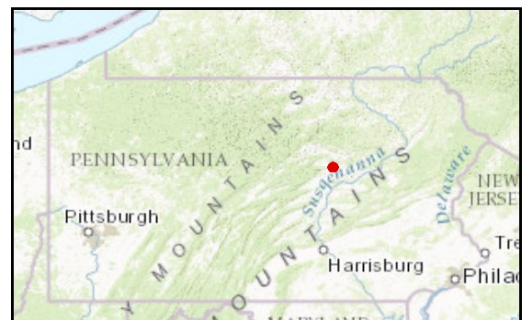

Service Layer Credits: Sources: Esri, HERE, DeLorme, Intermap, increment P Corp., GEBCO, USGS, FAO, NPS, NRCAN, GeoBase, IGN, Kadaster NL, Ordnance Survey, Esri Japan, METI, Esri China (Hong Kong), swisstopo, MapmyIndia, © OpenStreetMap contributors, and the GIS User Community
Esri, HERE, DeLorme, MapmyIndia, © OpenStreetMap contributors, and the GIS user

Act 537 Special Study Wastewater Treatment Plant Upgrade

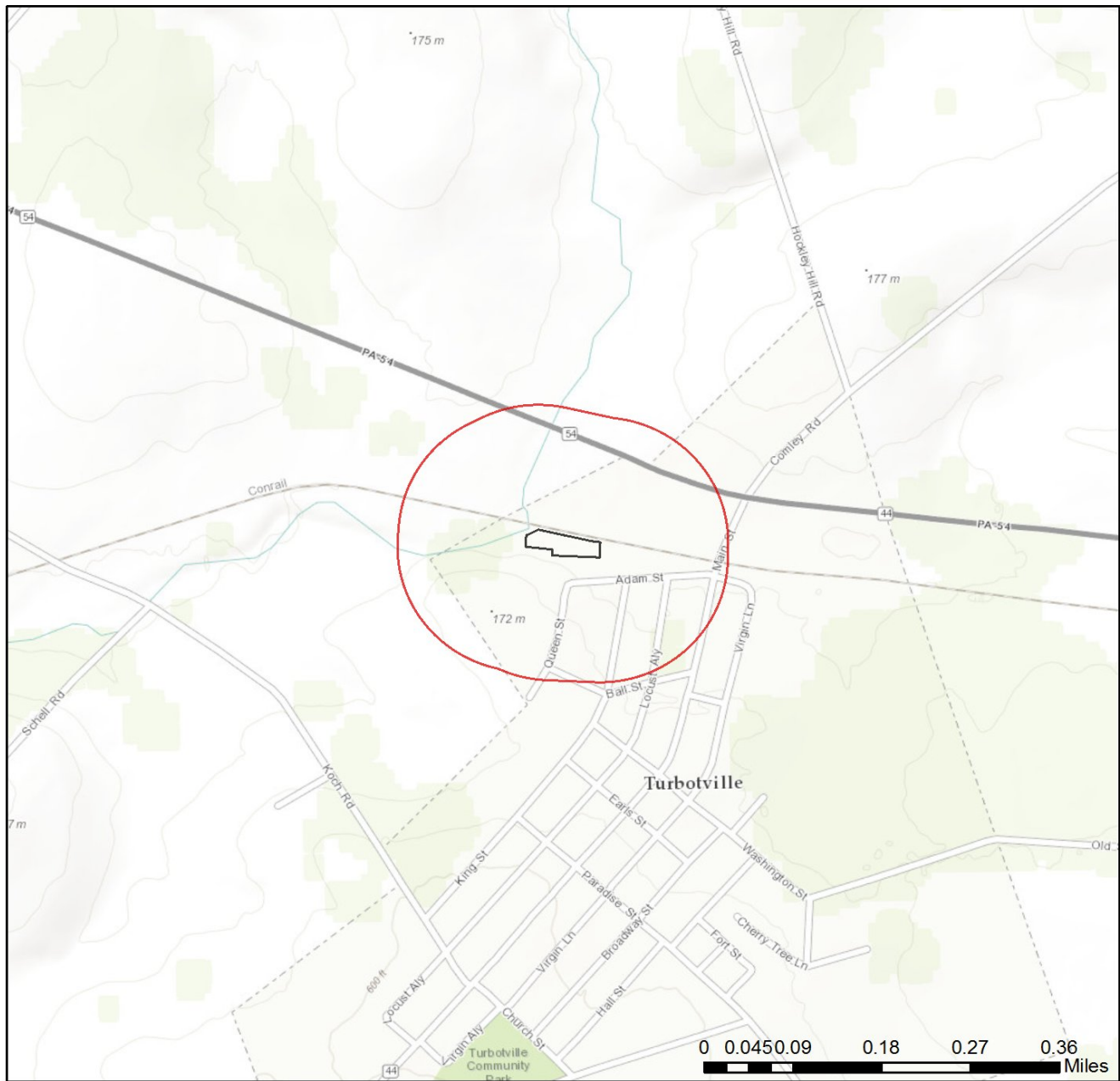

- Project Boundary
- Buffered Project Boundary

Service Layer Credits: Sources: Esri, HERE, DeLorme, Intermap, increment P Corp., GEBCO, USGS, FAO, NPS, NRCAN, GeoBase, IGN, Kadaster NL, Ordnance Survey, Esri Japan, METI, Esri China (Hong Kong), swisstopo, MapmyIndia, © OpenStreetMap contributors, and the GIS User Community



3. AGENCY COMMENTS

Regardless of whether a DEP permit is necessary for this proposed project, any potential impacts to threatened and endangered species and/or special concern species and resources must be resolved with the appropriate jurisdictional agency. In some cases, a permit or authorization from the jurisdictional agency may be needed if adverse impacts to these species and habitats cannot be avoided.

These agency determinations and responses are **valid for two years** (from the date of the review), and are based on the project information that was provided, including the exact project location; the project type, description, and features; and any responses to questions that were generated during this search. If any of the following change: 1) project location, 2) project size or configuration, 3) project type, or 4) responses to the questions that were asked during the online review, the results of this review are not valid, and the review must be searched again via the PNDI Environmental Review Tool and resubmitted to the jurisdictional agencies. The PNDI tool is a primary screening tool, and a desktop review may reveal more or fewer impacts than what is listed on this PNDI receipt. The jurisdictional agencies **strongly advise against** conducting surveys for the species listed on the receipt prior to consultation with the agencies.

PA Game Commission

RESPONSE:

No Impact is anticipated to threatened and endangered species and/or special concern species and resources.

PA Department of Conservation and Natural Resources

RESPONSE:

No Impact is anticipated to threatened and endangered species and/or special concern species and resources.

PA Fish and Boat Commission

RESPONSE:

No Impact is anticipated to threatened and endangered species and/or special concern species and resources.

U.S. Fish and Wildlife Service

RESPONSE:

No impacts to **federally** listed or proposed species are anticipated. Therefore, no further consultation/coordination under the Endangered Species Act (87 Stat. 884, as amended; 16 U.S.C. 1531 et seq. is required. Because no take of federally listed species is anticipated, none is authorized. This response does not reflect potential Fish and Wildlife Service concerns under the Fish and Wildlife Coordination Act or other authorities.

4. DEP INFORMATION

The Pa Department of Environmental Protection (DEP) requires that a signed copy of this receipt, along with any required documentation from jurisdictional agencies concerning resolution of potential impacts, be submitted with applications for permits requiring PNDI review. Two review options are available to permit applicants for handling PNDI coordination in conjunction with DEP's permit review process involving either T&E Species or species of special concern. Under sequential review, the permit applicant performs a PNDI screening and completes all coordination with the appropriate jurisdictional agencies prior to submitting the permit application. The applicant will include with its application, both a PNDI receipt and/or a clearance letter from the jurisdictional agency if the PNDI Receipt shows a Potential Impact to a species or the applicant chooses to obtain letters directly from the jurisdictional agencies. Under concurrent review, DEP, where feasible, will allow technical review of the permit to occur concurrently with the T&E species consultation with the jurisdictional agency. The applicant must still supply a copy of the PNDI Receipt with its permit application. The PNDI Receipt should also be submitted to the appropriate agency according to directions on the PNDI Receipt. The applicant and the jurisdictional agency will work together to resolve the potential impact(s). See the DEP PNDI policy at <https://conservationexplorer.dcnr.pa.gov/content/resources>.

5. ADDITIONAL INFORMATION

The PNDI environmental review website is a preliminary screening tool. There are often delays in updating species status classifications. Because the proposed status represents the best available information regarding the conservation status of the species, state jurisdictional agency staff give the proposed statuses at least the same consideration as the current legal status. If surveys or further information reveal that a threatened and endangered and/or special concern species and resources exist in your project area, contact the appropriate jurisdictional agency/agencies immediately to identify and resolve any impacts.

For a list of species known to occur in the county where your project is located, please see the species lists by county found on the PA Natural Heritage Program (PNHP) home page (www.naturalheritage.state.pa.us). Also note that the PNDI Environmental Review Tool only contains information about species occurrences that have actually been reported to the PNHP.

6. AGENCY CONTACT INFORMATION

PA Department of Conservation and Natural Resources

Bureau of Forestry, Ecological Services Section
400 Market Street, PO Box 8552
Harrisburg, PA 17105-8552
Email: RA-HeritageReview@pa.gov
Fax: (717) 772-0271

PA Fish and Boat Commission

Division of Environmental Services
450 Robinson Lane, Bellefonte, PA 16823
Email: RA-FBPACENOTIFY@pa.gov

U.S. Fish and Wildlife Service

Pennsylvania Field Office
Endangered Species Section
110 Radnor Rd; Suite 101
State College, PA 16801
NO Faxes Please

PA Game Commission

Bureau of Wildlife Habitat Management
Division of Environmental Planning and Habitat Protection
2001 Elmerton Avenue, Harrisburg, PA 17110-9797
Email: RA-PGC_PNDI@pa.gov
NO Faxes Please

7. PROJECT CONTACT INFORMATION

Name: Garrett A. Stoy
Company/Business Name: Uni-Tec Consulting Engineers, Inc.
Address: 2007 Cato Avenue
City, State, Zip: State College, PA, 16801
Phone: (814) 238-8223 ext. 341 Fax: (814) 838-7808
Email: gas@uni-tec.com

8. CERTIFICATION

I certify that ALL of the project information contained in this receipt (including project location, project size/configuration, project type, answers to questions) is true, accurate and complete. In addition, if the project type, location, size or configuration changes, or if the answers to any questions that were asked during this online review change, I agree to re-do the online environmental review.

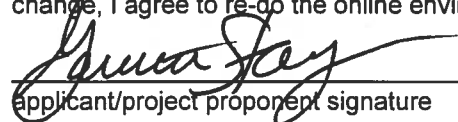
applicant/project proponent signature

01/11/2017

date

Appendix P
Cultural Resource Notice and PHMC Review



January 11, 2017
File No. 0047-043-000
Certified Mail No. 7015 1660 0000 9116 5187

Pennsylvania Historical and Museum Commission
Bureau of Historic Preservation
400 North Street, Second Floor
Harrisburg, PA 17120-0093

RE: Cultural Resource Notice
Act 537 Special Study
The Borough of Turbotville PA

Dear Pennsylvania Historical and Museum Commission:

The Borough of Turbotville is conducting an Act 537 Special Study. The study is to supplement the existing Act 537 in order to construct a new wastewater treatment plant, so that it will meet new effluent standards. The existing plant can be identified on the site plan attached to the file. On the site plan, the boundary of the project is outlined in red which encloses an area of 0.892 acres that will be utilized during the proposed project. The outline represents an existing fence that encloses the existing treatment plant. The proposed wastewater treatment plant will be constructed inside the red boundary on previously disturbed land. The confines of the fence limit the size and location of the project to within the outlined area.

The existing wastewater treatment plant consists of buildings located in the project area that were constructed in 1988. All of the buildings except for the Control Building will be demolished in order to make room for the new water treatment plant.

The remaining items have been attached per request of Section H. of the Cultural Resource Notice:

1. Cultural Resource Notice
2. 7.5' U.S.G.S. map indicating the defined boundary of the proposed activity
3. Return Receipt
4. Demolition Site Plan
5. Proposed Site Plan

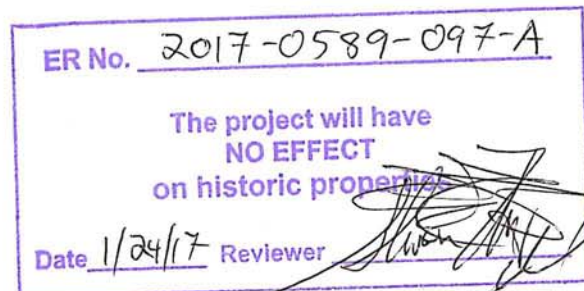

Should you have any questions or require additional information, please do not hesitate to contact me via email: gas@uni-tec.com or phone: (814) 238-8223 ext. 341

Sincerely,
UNI-TEC CONSULTING ENGINEERS, INC.



Garrett A. Stoy
Project Engineer

GAS/gas

Email cc: Michele A. Aukerman, P.E. Uni-Tec Consulting Engineers, Inc.



CULTURAL RESOURCE NOTICE

DEP USE ONLY
Date Received

Read the instructions before completing this form.

SECTION A. APPLICANT IDENTIFIER	
Applicant Name	<u>The Borough of Turbotville</u>
Street Address	<u>2 Adam Street</u>
City	<u>Turbotville</u> State <u>Pennsylvania</u> Zip <u>17772</u>
Telephone Number	<u>(570) 649-5476</u>
Project Title	<u>Act 537 Special Study - Wastewater Treatment Plant Upgrade</u>
SECTION B. LOCATION OF PROJECT	
Municipality	<u>The Borough of Turbotville</u> County Name <u>Northumberland</u> DEP County Code <u>49</u>
SECTION C. PERMITS OR APPROVALS	
Name of Specific DEP Permit or Approval Requested:	**Water Quality Management Part II Anticipated
Anticipated federal permits:	
<input type="checkbox"/> Surface Mining	<input type="checkbox"/> 404 Water Quality Permit
<input type="checkbox"/> Army Corps of Engineers	<input type="checkbox"/> Federal Energy Regulatory Commission
<input type="checkbox"/> 401 Water Quality Certification	<input type="checkbox"/> Other: _____
SECTION D. GOVERNMENT FUNDING SOURCES N/A	
<input type="checkbox"/> State: (Name) _____	<input type="checkbox"/> Local: (Name) _____
<input type="checkbox"/> Federal: (Name) _____	<input type="checkbox"/> Other: (Name) _____
SECTION E. RESPONSIBLE DEP REGIONAL, CENTRAL, DISTRICT MINING or OIL & GAS MGMT OFFICE	
DEP Regional Office Responsible for Review of Permit Application	<input type="checkbox"/> Central Office (Harrisburg)
<input type="checkbox"/> Southeast Regional Office (Norristown)	<input type="checkbox"/> Northeast Regional Office (Wilkes-Barre)
<input type="checkbox"/> Southcentral Regional Office (Harrisburg)	<input checked="" type="checkbox"/> Northcentral Regional Office (Williamsport)
<input type="checkbox"/> Southwest Regional Office (Pittsburgh)	<input type="checkbox"/> Northwest Regional Office (Meadville)
<input type="checkbox"/> District Mining Office: _____	<input type="checkbox"/> Oil & Gas Office: _____
SECTION F. RESPONSIBLE COUNTY CONSERVATION DISTRICT, if applicable.	
County Conservation District	Telephone Number, if known
<u>Northumberland County Conservation District</u>	<u>(570) 495-4665</u>
SECTION G. CONSULTANT	
Consultant, if applicable	<u>Garrett A. Stoy</u>
Street Address	<u>2007 Cato Avenue</u>
City	<u>State College</u> State <u>Pennsylvania</u> Zip <u>16801</u>
Telephone Number	<u>(814) 238-8223 ext. 341</u>

SECTION H. PROJECT BOUNDARIES AND DESCRIPTION

REQUIRED

Indicate the total acres in the property under review. Of this acreage, indicate the total acres of earth disturbance for the proposed activity. -Acreage stated in Cover Letter

Attach a 7.5' U.S.G.S. Map indicating the defined boundary of the proposed activity. -Attached

Attach photographs of any building over 50 years old. Indicate what is to be done to all buildings in the project area. -Not Applicable

Attach a narrative description of the proposed activity. -Stated in Cover Letter

Attach the return receipt of delivery of this notice to the Pennsylvania Historical and Museum Commission. -Return Receipt Attached

REQUESTED

Attach photographs of any building over 40 years old. - Not Applicable

Attach site map, if available. -Site Map Attached

SECTION I. SIGNATURE BLOCK

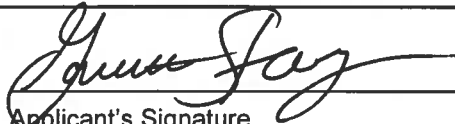
Applicant's Signature

01/11/2017
Date of Submission of Notice to PHMC

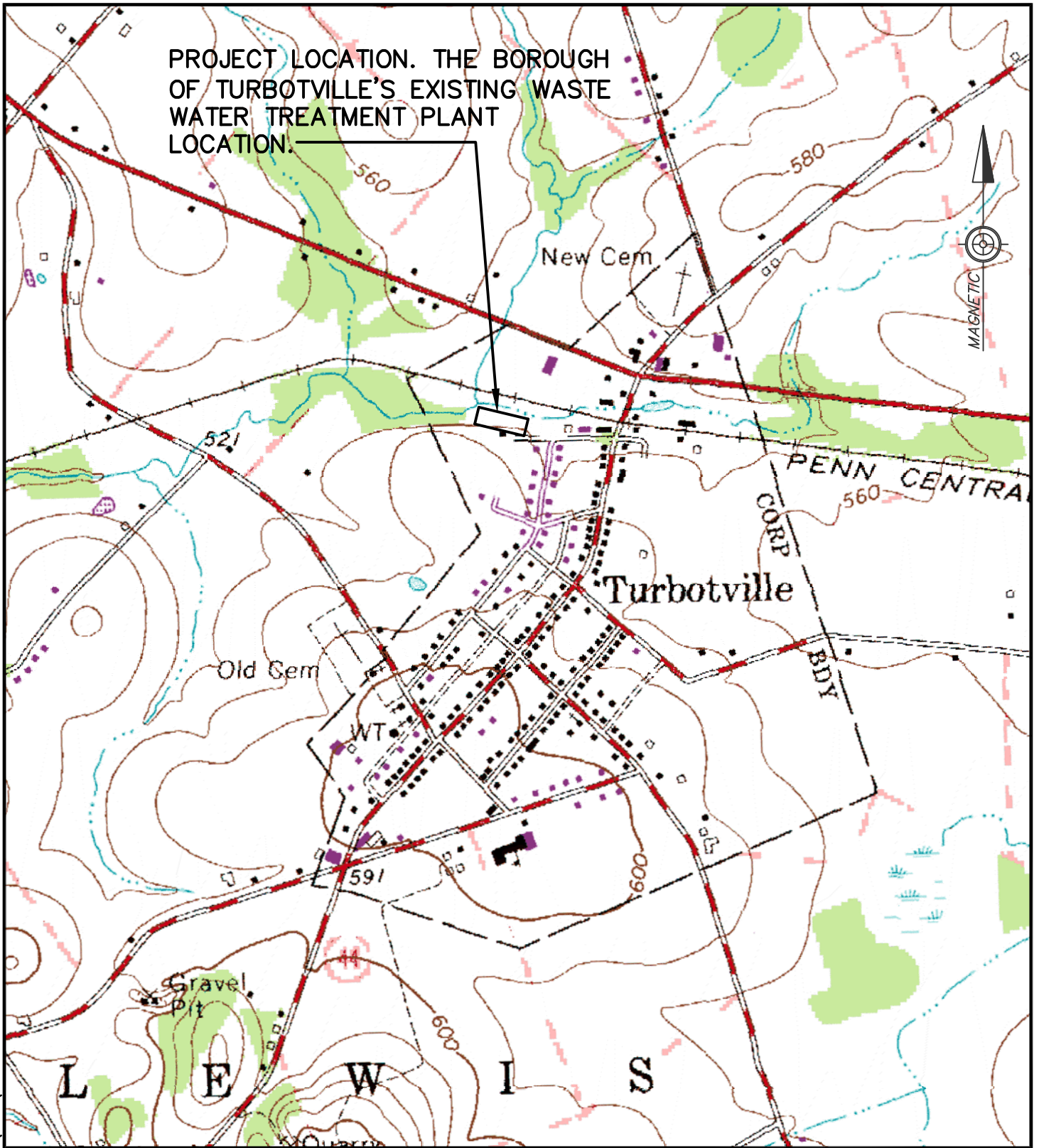

i:\0047\043000\CAD\SUP\LOC\LOC MAP1

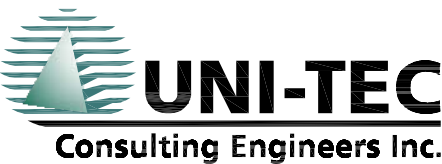

2007 Cato Avenue
 State College, PA 16801
 (814) 238-8223 www.uni-tec.com

WASTEWATER TREATMENT PLANT

BOROUGH OF TURBOTVILLE
 NORTHUMBERLAND COUNTY
 PENNSYLVANIA

LOCATION MAP
 JANUARY 2017

MILTON QUAD

SCALE

1"=1000'

PROJECT NO.

0047043101

SHEET NO.

1

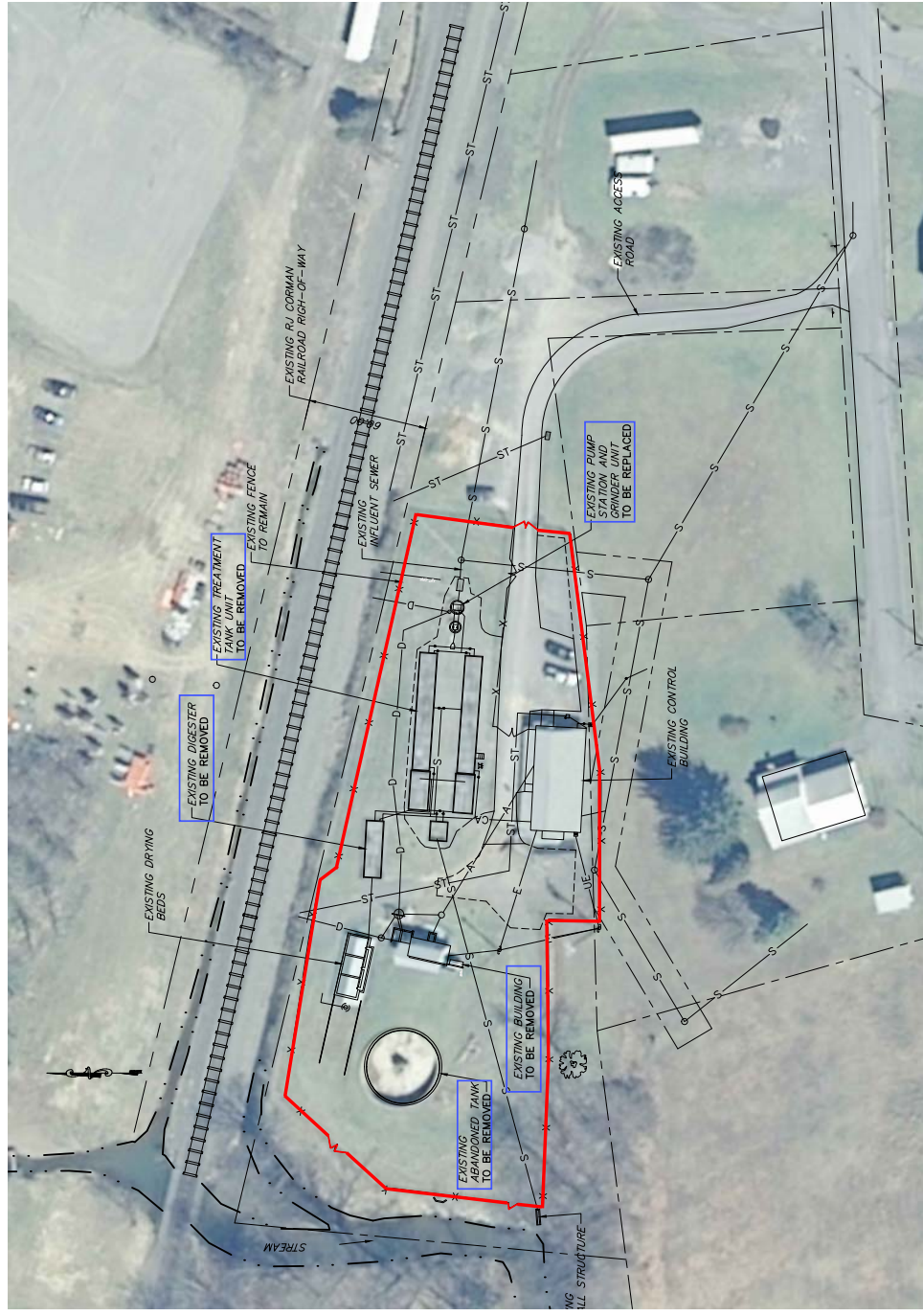

DEMOLITION SITE PLAN
 SCALE: 1"=30'

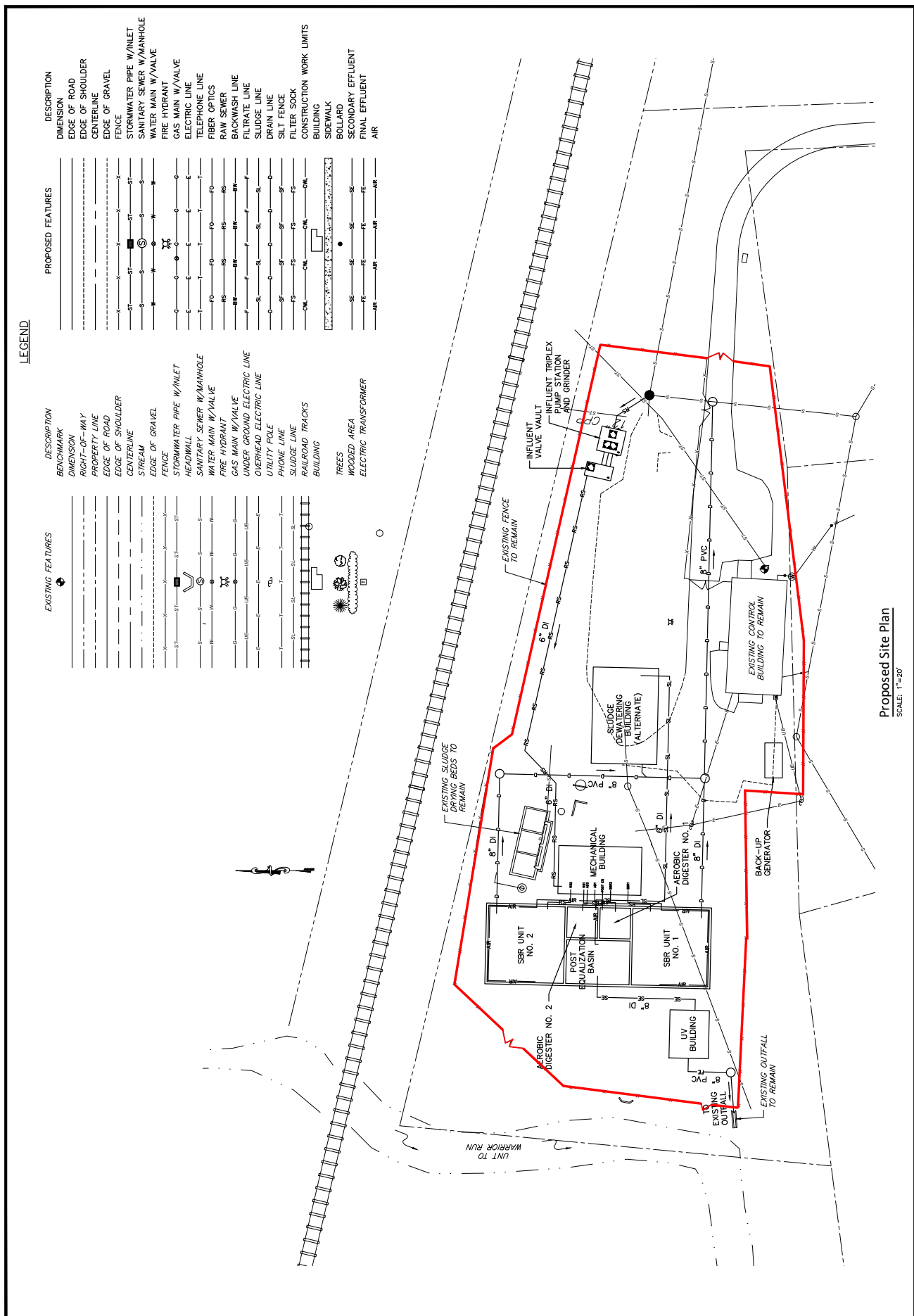

LEGEND

EXISTING FEATURES	DESCRIPTION
--- (dashed line)	BENCHMARK
--- (solid line)	DIMENSION
--- (dashed line)	RIGHT-OF-WAY
--- (dashed line)	PROPERTY LINE
--- (dashed line)	EDGE OF ROAD
--- (dashed line)	EDGE OF SHOULDER
--- (dashed line)	CENTERLINE
--- (dashed line)	STREAM
--- (dashed line)	EDGE OF GRAVEL
--- (dashed line)	FENCE
--- (dashed line)	STORMWATER PIPE W/INLET
--- (dashed line)	HEADWALL
--- (dashed line)	SANITARY SEWER W/MANHOLE
--- (dashed line)	WATER MAIN W/VALVE
--- (dashed line)	FIRE HYDRANT
--- (dashed line)	GAS MAIN W/VALVE
--- (dashed line)	UNDER GROUND ELECTRIC LINE
--- (dashed line)	UTILITY POLE
--- (dashed line)	PHONE LINE
--- (dashed line)	SLUDGE LINE
--- (dashed line)	RAILROAD TRACKS
--- (dashed line)	BUILDING
--- (dashed line)	TREES
--- (dashed line)	WOODED AREA
--- (dashed line)	ELECTRIC TRANSFORMER

PROPOSED FEATURES	DESCRIPTION
--- (dashed line)	DIMENSION
--- (dashed line)	EDGE OF ROAD
--- (dashed line)	EDGE OF SHOULDER
--- (dashed line)	CENTERLINE
--- (dashed line)	EDGE OF GRAVEL
--- (dashed line)	FENCE
--- (dashed line)	STORMWATER PIPE W/INLET
--- (dashed line)	SANITARY SEWER W/MANHOLE
--- (dashed line)	WATER MAIN W/VALVE
--- (dashed line)	FIRE HYDRANT
--- (dashed line)	GAS MAIN W/VALVE
--- (dashed line)	ELECTRIC LINE
--- (dashed line)	TELEPHONE LINE
--- (dashed line)	FIBER OPTICS
--- (dashed line)	RAW SEWER
--- (dashed line)	BACKWASH LINE
--- (dashed line)	FILTRATE LINE
--- (dashed line)	SLUDGE LINE
--- (dashed line)	DRAIN LINE
--- (dashed line)	SILT FENCE
--- (dashed line)	FILTER SOCK
--- (dashed line)	CONSTRUCTION WORK LIMITS
--- (dashed line)	BUILDING
--- (dashed line)	SIDEWALK
--- (dashed line)	BOLLARD
--- (dashed line)	SECONDARY EFFLUENT
--- (dashed line)	FINAL EFFLUENT
--- (dashed line)	AIR

Proposed Site Plan
 SCALE: 1"=20'

Appendix Q

**Public Notice of Study Review and Comment
Opportunity and Proof of Publication**

LEGAL NOTICE

PUBLIC NOTICE is hereby given that the Borough of Turbotville has conducted an *Act 537 Special Study* in accordance with the applicable provisions of the Pennsylvania Sewage Facilities Act of 1966, P.L. 1535, No. 537, as amended and supplemented, generally referred to as "Act 537", and codified in Chapter 71 (Administration of Sewage Facilities Planning Program) of Title 25 (Environmental Protection) adopted August 2, 1971, Sections 71.21 and 71.31, as amended. Pennsylvania municipalities are required to adopt an Official Sewage Facilities Plan (Act 537 Plan) that provides for sewage disposal services adequate to prevent contamination of waters and/or environmental health hazards and to revise said plan whenever it is necessary to meet the sewage disposal needs of the respective municipality.

The purpose of this *Special Study* is to supplement the existing Act 537 Plan of the Borough in order to identify the most cost-effective method to satisfy the upcoming treatment requirements of the Borough's existing sewage service area for the next 20-year planning period. In general, two treatment alternatives were selected for evaluation: (1) abandonment of the Borough's existing wastewater treatment plant and proposed conveyance of sewage to Milton Regional Sewer Authority for treatment, and (2) replacement of the Borough's existing plant with a new plant utilizing a sequencing batch reactor (SBR) system. As no wastewater activities are proposed within or beyond the current wastewater service area of Turbotville Borough, the scope for this *Special Study* was selected based upon the premise that the planning area is the existing wastewater treatment plant. Factors from outside the study area are addressed in regard to their related impact on the current treatment facility and proposed alternative.

Upon review of all factors, the Borough selected the alternative to replace its wastewater treatment plant with SBR technology. The preliminary opinion of potential user rates indicates that monthly rates for this alternative could range, based upon the amount of grant money in the funding received and terms of any loan, between \$64.45 and \$90.90 for each equivalent dwelling unit (EDU). Key implementation activities and associated schedule are included in the *Act 537 Special Study*. The Study determined that no discharge is proposed to a body of water designated as high quality or exceptional value.

Upon publication of this notice, a ***30-day review and comment period*** is in effect. Copies of the *Act 537 Special Study* are available for review at the office of the Borough of Turbotville, 267 Broadway Street, Turbotville, PA 17772, during normal hours. Interested parties can review the document and direct written comments to the Borough Secretary at Turbotville Borough, P.O. Box 264, Turbotville, PA 17772 within the ***30-day review and comment period***.

Borough of Turbotville

Advertising Receipt

Standard Journal

21 N. Arch Street
Milton, PA 17847

Phone: 570-742-9671

Fax: 570-742-9876

Turbotville Borough
Diane Miller
P.O. Box 264
2 Adam Street
TURBOTVILLE, PA 17772

Acct #: 01100108
Ad #: 00030896
Phone: (570)649-5476
Date: 03/02/2017
Ad taker: jd **Salesperson:**

Sort Line: Act 537 Special Study

Classification: 001

Description	Start	Stop	Ins.	Cost/Day	Total
01 Standard Journal	03/03/2017	03/03/2017	1	96.20	96.20
inte Internet charge					2.00
NOTE Notary Charge					5.00

Ad Text:

LEGAL NOTICE

Payment Reference:

PUBLIC NOTICE is hereby given that the Borough of Turbotville has conducted an Act 537 Special Study in accordance with the applicable provisions of the Pennsylvania Sewage Facilities Act of 1966, P.L. 1535, No. 537, as amended and supplemented, generally referred to as "Act 537", and codified in Chapter 71 (Administration of Sewage Facilities Planning Program) of Title 25 (Environmental Protection) adopted August 2, 1971, Sections 71.21 and 71.31, as amended. Pennsylvania municipalities are required to adopt an Official Sewage Facilities Plan (Act 537 Plan) that provides for sewage disposal services adequate to prevent contamination of waters and/or environmental health hazards and to revise said plan

Total: 103.20
Tax: 0.00
Net: 103.20
Prepaid: 0.00
Total Due 103.20

STANDARD JOURNAL

21 ARCH STREET
MILTON, PA 17847

Proof of Publication

Commonwealth of Pennsylvania
County of Northumberland

§

Personally appeared before me, the undersigned as Notary Public in and for said County and State.

Joanne Delmonico

who being duly sworn according to the law, doth depose and say that she is the

**Classified Advertising
Representative**

for the Standard Journal, a newspaper of general circulation published at Milton, County of Northumberland, Commonwealth of Pennsylvania, which was established January 23, 1890, and that a notice, copy of which is hereto attached, was published in said Standard Journal on

.....3/3/17.....
that affiant is not interested in the subject matter of the attached notice of advertising, and avers that all of the allegations of the statement as to the time, place, and character of the publication are true.

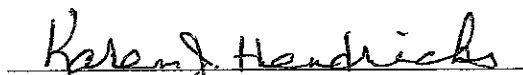

Sworn and subscribed before me this
..28th.....day of ..March, 2017...

Notary Public

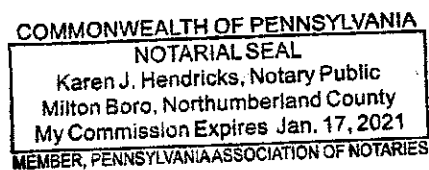



STANDARD JOURNAL

CLASSIFIEDS

LEGAL NOTICE

Sealed proposals will be received by the Township of Delaware, Northumberland County, 1960 Eighth Street Drive, PO Box 203 Watsonstown, PA 17777 until 2:00 P.M. prevailing time on April 4, 2017 for the following:

1.	5,000 tons	2RC	Aggregate delivered
2.	500 tons	1B	Aggregate delivered
3.	500 tons	1B washed	Aggregate delivered
4.	2,500	2B	Aggregate delivered
5.	10,000 tons	2A	Aggregate delivered
6.	1,000 tons	2	Aggregate delivered
7.	1,000 tons	AS4	Aggregate delivered
8.	500 tons	Gabion	Aggregate delivered
9.	500 tons	Rip Rap	Aggregate delivered
10.	250' tons	3	Aggregate delivered
11.	250 tons	4	Aggregate delivered
12.	150 tons	Cracker Dust	Delivered
13.	250 tons	AS4 Sandstone	Delivered
14.	250 tons	2 Sandstone	Delivered
15.	250 tons	2B Sandstone	Delivered
16.	250 tons	7 Sandstone	Delivered
17.	10,000 gallons	LS Diesel Fuel	Delivered
18.	10,000 gallons	Heating Oil; 1/2 heating, 1/2 kerosene	Off road diesel

All work and material must meet PA Department of Transportation specifications Form 408 dated 1983 and its supplements. Proposals must be upon the forms furnished by the Municipality. The bid must be accompanied by a certified check or bid bond in the amount of 10% of the bid, made payable to the Municipality. The Municipality reserves the right to reject any or all proposals.

**2016 AUDITOR'S REPORT
LEWIS TWP. - UNION COUNTY**

General Fund

Revenues			
Township Account Balance as of Jan 1, 2016	\$630,531		
Taxes	\$174,471		
Fines and Forfeits	\$1,654		
Interest Earnings	\$1,515		
Intergovernmental Revenues	\$60,641		
Public Safety	\$9,516		
Refunds	\$2,214		
Total Revenues & Balance	\$880,542	\$880,542	

Expenditures			
General Government	\$29,438		
Fire	\$24,966		
Ambulance	\$3,000		
Planning & Zoning	\$4,652		
Trash disposal	\$7,058		
Highways and Streets	\$100,882		
Insurance Premiums	\$10,884		
Employer Paid Benefits	\$13,322		
Unclassified Operating expenses	\$180		
Total Expenditures	\$194,382	\$194,382	

General Fund Balance 12/31/2016 **\$6,86,160**

State Fund Account

Revenues			
State Fund Account Balance as of Jan 1, 2016	\$4,753		
Motor Vehicle Fuel Tax	\$65,905		
Interest Earnings	\$81		
Total Revenues & Balance	\$70,739	\$70,739	

Expenditures			
Road and Bridge Maintenance	\$64,801		
Total Expenditures	\$64,801	\$64,801	

State Fund Balance **\$5,938**

Township Auditors: Joanne Boyer, Richard Troutman, Karen Troutman

Legal Notices

ESTATE NOTICE

Notice is hereby given that Letters of Testamentary on the Estate of JOHN M. VOUGHT, JR., a/k/a JOHN MARX VOUGHT, JR., late of 305 Tressler Blvd, Lewisburg, Union County, East Buffalo Township, Pennsylvania 17837, deceased, have been granted to the undersigned. All persons indebted to said estate are requested to make payment and those having claims against the same to present them for settlement to:

Joseph M. Vought
20853 Cherokee Terrace
Sterling, VA 20165

PETER L. MATSON, J.D.
Peter L. Matson, P.C.
222 Market Street
Lewisburg, PA 17837
(570) 523-3285

NOTICE

Notice is hereby given that Lewisburg Area School District is requesting proposals for Contracted School Bus Transportation. Proposals are due Friday March 31, 2017 at 3:00pm. Please visit www.lasd.us for RFP information.

LEGAL NOTICE

PUBLIC NOTICE is hereby given that the Borough of Turbotville has conducted an Act 537 Special Study in accordance with the applicable provisions of the Pennsylvania Sewage Facilities Act of 1966, P.L. 1535, No. 537, as amended and supplemented, generally referred to as "Act 537", and codified in Chapter 71 (Administration of Sewage Facilities Planning Program) of Title 25 (Environmental Protection) adopted August 2, 1971, Sections 71.21 and 71.31, as amended. Pennsylvania municipalities are required to adopt an Official Sewage Facilities Plan (Act 537 Plan) that provides for sewage disposal services adequate to prevent contamination of waters and/or environmental health hazards and to revise said plan whenever it is necessary to meet the

Legal Notices

sewage disposal needs of the respective municipality.

The purpose of this Special Study is to supplement the existing Act 537 Plan of the Borough in order to identify the most cost-effective method to satisfy the upcoming treatment requirements of the Borough's existing sewage service area for the next 20-year planning period. In general, two treatment alternatives were selected for evaluation: (1) abandonment of the Borough's existing wastewater treatment plant and proposed conveyance of sewage to Milton Regional Sewer Authority for treatment, and (2) replacement of the Borough's existing plant with a new plant utilizing a sequencing batch reactor (SBR) system. As no wastewater activities are proposed within or beyond the current wastewater service area of Turbotville Borough, the scope for this Special Study was selected based upon the premise that the planning area is the existing wastewater treatment plant. Factors from outside the study area are addressed in regard to their related impact on the current treatment facility and proposed alternative.

Upon review of all factors, the Borough selected the alternative to replace its wastewater treatment plant with SBR technology. The preliminary opinion of potential user rates indicates that monthly rates for this alternative could range, based upon the amount of grant money in the funding received and terms of any loan, between \$64.45 and \$90.90 for each equivalent dwelling unit (EDU). Key implementation activities and associated schedule are included in the Act 537 Special Study. The Study determined that no discharge is proposed to a body of water designated as high quality or exceptional value.

Upon publication of this notice, a 30-day review and comment period is in effect. Copies of the Act 537 Special Study are available for review at the office of the Borough

Legal Notices

of Turbotville, 267 Broadway Street, Turbotville, PA 17772, during normal hours. Interested parties can review the document and direct written comments to the Borough Secretary at Turbotville Borough, P.O. Box 284, Turbotville, PA 17772 within the 30-day review and comment period.

Borough of Turbotville

Lost and Found

FOUND DOG

This little dog was found on 2/24 in a rural area of Montandon. Owner should call Haven to Home at 570-894-5067 and be able to provide identifying information.



Adoption

Adopt:

A loving married couple long to adopt infant. Will provide a loving home, sensitivity and endless love. Expenses paid. Please call Diane & George 888-250-3557

Help Wanted

CAREGIVERS

Keystone Care First Home Health Care Agency is looking for caregivers in the Sunbury/Norry area, 2nd & 3rd shifts area, Millinburg area 3rd shift. SIGN ON BONUS call 570-784-2005.

Caretaker's Position available at Union County facility
Experience with general repairs, plumbing, small engine, equipment operation and repairs. Also, required are computer and good people skills. Qualified persons send resume to: Caretakers Position, P. O. Box 131, Williamsport, PA 17703, by March 10, 2017.
Driver wanted for small Turbotville business. Livestock, 4 nights a week & general hauling. CDL Class A. Must be 23 and have 2 years current exp. 570-850-7247

TRUCK DRIVER

Must have CDL Class A with Hazmat
3 Years Clean Driving Record
and 2 Years Experience

**Hauling Liquid Asphalt
Seasonal (Construction Work)**

Apply at H.L. Klose & Sons
265 Mulberry St., Millifinburg, PA 17844
No Phone Calls Please

Appendix R
Review Request Letters to Planning Agencies
and Proofs of Receipt



March 1, 2017
File No. 0047-043-001
Certified Mail 7016 3010 0001 1696 9169

Turbotville Borough Planning Commission
P.O. Box 264
Turbotville, PA 17772

RE: Act 537 Special Study
Borough of Turbotville

Dear Planning Commission Members:

On behalf of the Borough of Turbotville, please find enclosed one (1) copy of the Draft Act 537 Special Study for Turbotville Borough to address future sewage facilities needs at the existing Wastewater Treatment Plant and determine the most cost-effective alternative that is consistent with Local, State, and Federal regulations.

In the Special Study, the Borough has selected the alternative to upgrade its existing Wastewater Treatment Plant.

The Special Study will be publically advertised and available for review and comment during a 30-day public comment period. The Borough welcomes any comments you may have on the Study's proposed impact on zoning, land use, or other concerns. We respectfully request any written comments on the Study be forwarded to the Borough at P.O. Box 264, Turbotville, PA 17772 by **Friday, March 31st**. If you have no comments on the Study, we would appreciate a simple letter stating that fact also be sent to the Borough by this date. Any comments received will be included in the final version of the Special Study prior to submission to the PA Department of Environmental Protection.

Should you have any questions or need additional information, please do not hesitate to contact me at (814) 238-8223, ext. 360 or by email: maa@uni-tec.com.

Sincerely,
UNI-TEC CONSULTING ENGINEERS, INC.

A handwritten signature in blue ink that reads "Michele A. Aukerman".

Michele A. Aukerman, P.E.
Project Engineer

Enclosure

MAA

SENDER: COMPLETE THIS SECTION

- Complete items 1, 2, and 3.
- Print your name and address on the reverse so that we can return the card to you.
- Attach this card to the back of the mailpiece, or on the front if space permits.

1 Article Addressed to:

**Turbotville Borough Planning Commission
 P.O. Box 264
 Turbotville, PA 17772**



9590 9402 2490 6306 5492 51

2 Article Number (Transfer from service label)

7016 3010 0001 1696 9169

COMPLETE THIS SECTION ON DELIVERY

A. Signature
Chiane Miller Agent Addressee

B. Received by (Printed Name) *Diane Miller* C. Date of Delivery *3-3-17*

D. Is delivery address different from item 1? Yes No
 If delivery address below: Yes No

- Adult Signature
- Adult Signature Restricted Delivery
- Certified Mail®
- Certified Mail Restricted Delivery
- Collect on Delivery
- Collect on Delivery Restricted Delivery
- Insured Mail (over \$500)
- Priority Mail Express®
- Registered Mail™
- Registered Mail Restricted Delivery
- Return Receipt for Merchandise
- Signature Confirmation™
- Signature Confirmation Restricted Delivery

Domestic Return Receipt



March 1, 2017
File No. 0047-043-001
Certified Mail 7016 3010 0001 1696 9152

Northumberland County Planning Commission
339 Stadium Drive
Sunbury, PA 17801

RE: Act 537 Special Study
Borough of Turbotville

Dear Planning Commission Members:

On behalf of the Borough of Turbotville, please find enclosed one (1) copy of the Draft Act 537 Special Study for Turbotville Borough to address future sewage facilities needs at the existing Wastewater Treatment Plant and determine the most cost-effective alternative that is consistent with Local, State, and Federal regulations.

In the Special Study, the Borough has selected the alternative to upgrade its existing Wastewater Treatment Plant.

The Special Study will be publically advertised and available for review and comment during a 30-day public comment period. The Borough welcomes any comments you may have on the Study's proposed impact on zoning, land use, or other concerns. We respectfully request any written comments on the Study be forwarded to the Borough at P.O. Box 264, Turbotville, PA 17772 by **Friday, March 31st**. If you have no comments on the Study, we would appreciate a simple letter stating that fact also be sent to the Borough by this date. Any comments received will be included in the final version of the Special Study prior to submission to the PA Department of Environmental Protection.

Should you have any questions or need additional information, please do not hesitate to contact me at (814) 238-8223, ext. 360 or by email: maa@uni-tec.com.

Sincerely,
UNI-TEC CONSULTING ENGINEERS, INC.

A handwritten signature in blue ink that reads "Michele A. Aukerman".

Michele A. Aukerman, P.E.
Project Engineer

Enclosure

MAR

SENDER: COMPLETE THIS SECTION

- Complete items 1, 2, and 3.
- Print your name and address on the reverse so that we can return the card to you.
- Attach this card to the back of the mailpiece, or on the front if space permits.

COMPLETE THIS SECTION ON DELIVERY

A. Signature

Ronald Stolt

- Agent
- Addressee

B. Received by (Printed Name)

RONALD STOLT

C. Date of Delivery

3-3-17

- Address different from item 1? Yes
- delivery address below: No

Northumberland County Planning Commission
 339 Stadium Dr.
 Sunbury, PA 17801



9590 9402 2490 6306 5492 68

7016 3010 0001 1696 9152

- Adult Signature
- Adult Signature Restricted Delivery
- Certified Mail®
- Certified Mail Restricted Delivery
- Collect on Delivery
- Collect on Delivery Restricted Delivery
- Mail
- Mail Restricted Delivery
- Priority Mail Express®
- Registered Mail™
- Registered Mail Restricted Delivery
- Return Receipt for Merchandise
- Signature Confirmation™
- Signature Confirmation Restricted Delivery

PS Form 3811, July 2015 PSN 7530-02-000-9053

Domestic Return Receipt



March 1, 2017
File No. 0047-043-001
Certified Mail 7016 3010 0001 1696 9145

Northumberland County Agricultural Land Preservation Board
c/o Northumberland County Conservation District
441 Plum Creek Road
Sunbury, PA 17801

RE: Act 537 Special Study
Borough of Turbotville

Dear Board Members:

On behalf of the Borough of Turbotville, please find enclosed one (1) copy of the Draft Act 537 Special Study for Turbotville Borough to address future sewage facilities needs at the existing Wastewater Treatment Plant and determine the most cost-effective alternative that is consistent with Local, State, and Federal regulations.

In the Special Study, the Borough has selected the alternative to upgrade its existing Wastewater Treatment Plant.

The Special Study will be publically advertised and available for review and comment during a 30-day public comment period. The Borough welcomes any comments you may have on the Study's proposed impact on zoning, land use, or other concerns. We respectfully request any written comments on the Study be forwarded to the Borough at P.O. Box 264, Turbotville, PA 17772 by **Friday, March 31st**. If you have no comments on the Study, we would appreciate a simple letter stating that fact also be sent to the Borough by this date. Any comments received will be included in the final version of the Special Study prior to submission to the PA Department of Environmental Protection.

Should you have any questions or need additional information, please do not hesitate to contact me at (814) 238-8223, ext. 360 or by email: maa@uni-tec.com.

Sincerely,
UNI-TEC CONSULTING ENGINEERS, INC.

A handwritten signature in blue ink that reads "Michele A. Aukerman".

Michele A. Aukerman, P.E.
Project Engineer

Enclosure

MAR

SENDER: COMPLETE THIS SECTION

- Complete items 1, 2, and 3.
- Print your name and address on the reverse so that we can return the card to you.
- Attach this card to the back of the mailpiece, or on the front if space permits.

COMPLETE THIS SECTION ON DELIVERY

A. Signature
 x *[Handwritten Signature]* Agent
 Addressee

B. Received by (Printed Name)
 C. Date of Delivery
 3-3-17

Delivery address different from item 1? Yes
 delivery address below: No

Northumberland Co Agricultural Land Preservation Board
 C/O Northumberland County Conservation District
 441 Plum Creek Road
 Sunbury, PA 17801



9590 9402 2490 6306 5492 75

Article Number (Transfer from service label)

7016 3010 0001 1696 9145

- Adult Signature
- Adult Signature Restricted Delivery
- Certified Mail®
- Certified Mail Restricted Delivery
- Collect on Delivery
- Collect on Delivery Restricted Delivery
- Registered Mail™
- Registered Mail Restricted Delivery
- Return Receipt for Merchandise
- Signature Confirmation™
- Signature Confirmation Restricted Delivery
- Priority Mail Express®

Appendix S
Comments Received on Special Study and
Borough Responses

Turbotville Borough

267 Broadway Street, PO Box 264 Turbotville, PA 17772

Ph. 570-649-5476 Fax 570-649-6620

turbotville5476@windstream.net

April 3, 2017

To Whom it May Concern:

On behalf of the Borough of Turbotville, I certify that no comments were received from the public following the public notice of the Act 537 Special Study that was advertised on March 3, 2017 in the Standard Journal, a newspaper of general circulation.

Sincerely,



Diane Miller

Turbotville Borough

Turbotville Borough Planning Commission
PO Box 264
Turbotville, PA 17772

March 27, 2017

Turbotville Borough
P.O. Box 264
Turbotville, PA 17772

Re : Act 537 Special Study

Dear Borough Council:

The Turbotville Borough Planning Commission received a draft copy of the Borough's Act 537 Special Study on March 3, 2017.

The Planning Commission has no comments on the Special Study and the Study's recommendation, Upgrade of the Existing Wastewater Treatment Plant, is consistent with the Municipal Zoning Ordinance of 2014 for the Borough of Turbotville.

If you have any additional questions, please do not hesitate to contact us.

Sincerely,

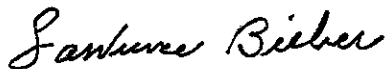

Lawrence Bieber
Planning Commission
Chairperson

PLANNING DEPARTMENT

COMMISSIONERS

Richard J. Shoch, Chairman
Samuel J. Schiccatano
Kymberley L. Best



Donald E. Alexander
Director of Planning and
Economic Development
Voice: 570-988-4220
Fax: 570-988-4436

EMAIL: don.alexander@norrycopa.net

MAILING ADDRESS

Administration Center
399 Stadium Drive, Suite 207
Sunbury, PA 17801

COUNTY LAND USE LETTER

Received APR 03 2017

DATE: March 28, 2017
TO: Michele A. Aukerman, UNI-TEC
FROM: Northumberland County Planning Agency
SUBJECT: Borough of Turbotville, Act 537 Special Study

The County of Northumberland states that it:

X has adopted a county or multi-county comprehensive plan. If yes, please provide date of adoption: April 2005

has not adopted a county or multi-county comprehensive plan.

The above referenced project:

X is consistent with the adopted county or multi-county comprehensive plan.

is not consistent with the adopted county or multi-county comprehensive plan.

Additional comments (attach additional sheets if necessary):

Submitted by:

Name: Donald E. Alexander
Title: Director of Planning and Economic Development
Address: 399 Stadium Drive
Sunbury, PA 17801
(570)988-4343

Signature:
Date:

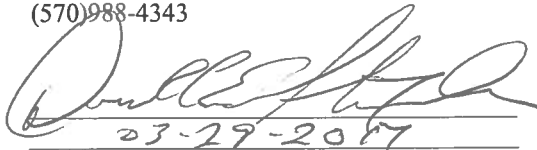
03-29-2017

AGRICULTURAL LAND PRESERVATION BOARD

COMMISSIONERS
Richard J. Shoch, Chairman
Samuel J. Schiccatano
Kymberley L. Best



William Geise, Chairperson
Rich Daniels, Vice-Chairperson
Judy Becker, Administrator

Northumberland County Conservation District
441 Plum Creek Road
Sunbury, PA 17801
Phone: 570-495-4665 ext. 305

In Cooperation With

Natural Resources Conservation Service
441 Plum Creek Road
Sunbury, PA 17801
Phone: 570-286-7114 ext. 3

March 31, 2017

Turbotville Borough
PO Box 264
Turbotville, PA 17772

RE: Act 537 Special Study
Borough of Turbotville

Dear Turbotville Borough Council:

Please be advised that the Northumberland County Agricultural Land Preservation Board has reviewed your municipal wastewater project as requested.

We understand that your project will not adversely affect existing agricultural land uses within the project service area. Therefore, I see no conflicts between the Turbotville Borough Act 537 Special Study and the Agricultural Land Preservation Program in relation with the Farmland Protection Policy Act of 1981.

If you have any further questions regarding this project and the Agricultural Land Preservation Program, please feel free to contact me at (570) 495-4665 extension 305. Thank you for taking the time to inform me of this matter.

Sincerely,

Judy Becker
Administrator
Northumberland County
Agricultural Land Preservation Program

Appendix T
Turbotville Borough Resolution to Adopt
Special Study

BOROUGH OF TURBOTVILLE
NORTHUMBERLAND COUNTY, PENNSYLVANIA

RESOLUTION NO. 4-17

RESOLUTION OF THE TURBOTVILLE BOROUGH COUNCIL,
NORTHUMBERLAND COUNTY, PENNSYLVANIA (hereinafter "the municipality").

WHEREAS, Section 5 of the Act of January 24, 1966, P.L. 1535, No. 537, known as the "Pennsylvania Sewage Facilities Act," as amended, and the Rules and Regulations of the Department of Environmental Protection (Department) adopted thereunder, Chapter 71 of Title 25 of the Pennsylvania Code, requires the municipality to adopt an Official Sewage Facilities Plan providing for sewage services adequate to prevent contamination of waters and/or environmental health hazards with sewage wastes, and to revise said plan whenever it is necessary to meet the sewage disposal needs of the municipality, and

WHEREAS, TURBOTVILLE BOROUGH has prepared an *Act 537 Special Study* which serves as a supplement to the Official Sewage Facilities Plan and provides for sewage facilities in a portion of Turbotville Borough, and

The alternative of choice to be implemented is a wastewater treatment plant upgrade incorporating a sequencing batch reactor system and associated process components. The key implementation schedule calls for project permitting and funding applications to be completed by August 2017 and for project construction completion by winter 2018/2019. The detailed schedule of key implementation activities is included in the *Act 537 Special Study*.

WHEREAS, Turbotville Borough finds that the *Act 537 Special Study* described above, conforms to applicable zoning, subdivision, other municipal ordinances and plans and to a comprehensive program of pollution control and water quality management.

NOW, THEREFORE, BE IT RESOLVED that the Council of the Borough of Turbotville hereby adopt and submit to the Pennsylvania Department of Environmental Protection for its approval as a revision to the "Official Plan" of the municipality, the above referenced *Act 537 Special Study*. The municipality hereby assures the Department that said plan will be implemented as required by law. (Section 5, Pennsylvania Sewage Facilities Act as amended).

Duly adopted April 3, 2017

Attest:

Secretary

Council President



Mayor

Appendix B
Turbotville WWTP NPDES Permit



**AUTHORIZATION TO DISCHARGE UNDER THE
NATIONAL POLLUTANT DISCHARGE ELIMINATION SYSTEM
DISCHARGE REQUIREMENTS FOR PUBLICLY OWNED
TREATMENT WORKS (POTWs)**

NPDES PERMIT NO: PA0028100

In compliance with the provisions of the Clean Water Act, 33 U.S.C. Section 1251 *et seq.* ("the Act") and Pennsylvania's Clean Streams Law, as amended, 35 P.S. Section 691.1 *et seq.*,

**Turbotville Borough
2 Adam Street PO Box 264
Turbotville, PA 17772-9069**

is authorized to discharge from a facility known as **Turbotville Borough Wastewater Treatment Plant**, located in **Turbotville Borough, Northumberland County**, to **Unnamed Tributary to Warrior Run** in Watershed(s) **10-D** in accordance with effluent limitations, monitoring requirements and other conditions set forth in Parts A, B and C hereof.

THIS PERMIT SHALL BECOME EFFECTIVE ON SEPTEMBER 1, 2015

THIS PERMIT SHALL EXPIRE AT MIDNIGHT ON AUGUST 31, 2020

The authority granted by this permit is subject to the following further qualifications:

1. If there is a conflict between the application, its supporting documents and/or amendments and the terms and conditions of this permit, the terms and conditions shall apply.
2. Failure to comply with the terms, conditions or effluent limitations of this permit is grounds for enforcement action; for permit termination, revocation and reissuance, or modification; or for denial of a permit renewal application. (40 CFR 122.41(a))
3. A complete application for renewal of this permit, or notice of intent to cease discharging by the expiration date, must be submitted to DEP at least 180 days prior to the above expiration date (unless permission has been granted by DEP for submission at a later date), using the appropriate NPDES permit application form. (40 CFR 122.41(b), 122.21(d))

In the event that a timely and complete application for renewal has been submitted and DEP is unable, through no fault of the permittee, to reissue the permit before the above expiration date, the terms and conditions of this permit, including submission of the Discharge Monitoring Reports (DMRs), will be automatically continued and will remain fully effective and enforceable against the discharger until DEP takes final action on the pending permit application. (25 Pa. Code §§ 92a.7(b), (c))

4. This NPDES permit does not constitute authorization to construct or make modifications to wastewater treatment facilities necessary to meet the terms and conditions of this permit.

DATE PERMIT ISSUED AUGUST 17, 2015

ISSUED BY /s/

**Thomas M. Randis
Clean Water Program Manager
Northcentral Regional Office**

PART A - EFFLUENT LIMITATIONS, MONITORING, RECORDKEEPING AND REPORTING REQUIREMENTS

I. A. For Outfall 001, Latitude 41° 6' 23.10", Longitude 76° 46' 21.30", River Mile Index 1.33, Stream Code 19158

Receiving Waters: Unnamed Tributary to Warrior Run

Type of Effluent: Sewage

1. The permittee is authorized to discharge during the period from Permit Effective Date through May 31, 2018.
2. Based on the anticipated wastewater characteristics and flows described in the permit application and its supporting documents and/or amendments, the following effluent limitations and monitoring requirements apply (see also Additional Requirements and Footnotes).

Parameter	Effluent Limitations						Monitoring Requirements	
	Mass Units (lbs/day) ⁽¹⁾		Concentrations (mg/L)				Minimum ⁽²⁾ Measurement Frequency	Required Sample Type
	Average Monthly	Weekly Average	Minimum	Average Monthly	Weekly Average	Instant. Maximum		
Flow (MGD)	Report	Report Daily Max	XXX	XXX	XXX	XXX	Continuous	Metered
pH (S.U.)	XXX	XXX	6.0	XXX	XXX	9.0	1/day	Grab
Dissolved Oxygen	XXX	XXX	Report	XXX	XXX	XXX	1/day	Grab
Total Residual Chlorine	XXX	XXX	XXX	0.45	XXX	1.48	1/day	Grab
CBOD5	13	20	XXX	12	18	24	1/week	8-Hr Composite
BOD5 Raw Sewage Influent	Report	Report Daily Max	XXX	Report	XXX	XXX	1/week	8-Hr Composite
Total Suspended Solids	34	34	XXX	30	30	30	1/week	8-Hr Composite
Total Suspended Solids Raw Sewage Influent	Report	Report Daily Max	XXX	Report	XXX	XXX	1/week	8-Hr Composite
Fecal Coliform (CFU/100 ml) May 1 - Sep 30	XXX	XXX	XXX	200 Geo Mean	XXX	1,000	1/week	Grab

Outfall 001, Continued (from Permit Effective Date through May 31, 2018)

Parameter	Effluent Limitations						Monitoring Requirements	
	Mass Units (lbs/day) ⁽¹⁾		Concentrations (mg/L)				Minimum ⁽²⁾ Measurement Frequency	Required Sample Type
	Average Monthly	Weekly Average	Minimum	Average Monthly	Weekly Average	Instant. Maximum		
Fecal Coliform (CFU/100 ml) Oct 1 - Apr 30	XXX	XXX	XXX	2,000 Geo Mean	XXX	10,000	1/week	Grab
Ammonia-Nitrogen May 1 - Oct 31	7.0	10	XXX	6.0	9.0	12	1/week	8-Hr Composite
Ammonia-Nitrogen Nov 1 - Apr 30	20	31	XXX	18	27	36	1/week	8-Hr Composite
Total Phosphorus	Report	Report	XXX	Report	Report	XXX	1/week	8-Hr Composite
Total Copper	Report	Report Daily Max	XXX	Report	Report Daily Max	XXX	1/month	8-Hr Composite
Total Lead	Report	Report Daily Max	XXX	Report	Report Daily Max	XXX	1/month	8-Hr Composite

Samples taken in compliance with the monitoring requirements specified above shall be taken at the following location(s):

at Outfall 001

PART A - EFFLUENT LIMITATIONS, MONITORING, RECORDKEEPING AND REPORTING REQUIREMENTS

I. B. For Outfall 001, Latitude 41° 6' 23.10", Longitude 76° 46' 21.30", River Mile Index 1.33, Stream Code 19158

Receiving Waters: Unnamed Tributary to Warrior Run

Type of Effluent: Sewage

1. The permittee is authorized to discharge during the period from June 1, 2018 through Permit Expiration Date.
2. Based on the anticipated wastewater characteristics and flows described in the permit application and its supporting documents and/or amendments, the following effluent limitations and monitoring requirements apply (see also Additional Requirements and Footnotes).

Parameter	Effluent Limitations						Monitoring Requirements	
	Mass Units (lbs/day) ⁽¹⁾		Concentrations (mg/L)				Minimum ⁽²⁾ Measurement Frequency	Required Sample Type
	Average Monthly	Weekly Average	Minimum	Average Monthly	Weekly Average	Instant. Maximum		
Flow (MGD)	Report	Report Daily Max	XXX	XXX	XXX	XXX	Continuous	Metered
pH (S.U.)	XXX	XXX	6.0	XXX	XXX	9.0	1/day	Grab
Dissolved Oxygen	XXX	XXX	Report	XXX	XXX	XXX	1/day	Grab
Total Residual Chlorine	XXX	XXX	XXX	0.45	XXX	1.48	1/day	Grab
CBOD5	13	20	XXX	12	18	24	1/week	8-Hr Composite
BOD5 Raw Sewage Influent	Report	Report Daily Max	XXX	Report	XXX	XXX	1/week	8-Hr Composite
Total Suspended Solids Raw Sewage Influent	Report	Report Daily Max	XXX	Report	XXX	XXX	1/week	8-Hr Composite
Total Suspended Solids	34	34	XXX	30	30	30	1/week	8-Hr Composite
Fecal Coliform (CFU/100 ml) May 1 - Sep 30	XXX	XXX	XXX	200 Geo Mean	XXX	1,000	1/week	Grab

Outfall 001, Continued (from June 1, 2018 through Permit Expiration Date)

Parameter	Effluent Limitations						Monitoring Requirements	
	Mass Units (lbs/day) ⁽¹⁾		Concentrations (mg/L)				Minimum ⁽²⁾ Measurement Frequency	Required Sample Type
	Average Monthly	Weekly Average	Minimum	Average Monthly	Weekly Average	Instant. Maximum		
Fecal Coliform (CFU/100 ml) Oct 1 - Apr 30	XXX	XXX	XXX	2,000 Geo Mean	XXX	10,000	1/week	Grab
Ammonia-Nitrogen May 1 - Oct 31	4.0	5.5	XXX	3.5	5.0	7.0	1/week	8-Hr Composite
Ammonia-Nitrogen Nov 1 - Apr 30	11.5	17	XXX	10.5	15	21	1/week	8-Hr Composite
Total Phosphorus	2.96	2.96	XXX	2.60	2.60	2.60	1/week	8-Hr Composite
Total Copper (µg/L)	0.04	0.08 Daily Max	XXX	36.31	72.62 Daily Max	90.77	1/month	8-Hr Composite
Total Lead	Report	Report Daily Max	XXX	Report	Report Daily Max	XXX	1/month	8-Hr Composite

Samples taken in compliance with the monitoring requirements specified above shall be taken at the following location(s):

at Outfall 001

**PART A - EFFLUENT LIMITATIONS, MONITORING, RECORDKEEPING AND REPORTING REQUIREMENTS
(Continued)**

Additional Requirements

1. The permittee may not discharge:
 - a. Floating solids, scum, sheen or substances that result in observed deposits in the receiving water. (25 Pa Code § 92a.41(c))
 - b. Oil and grease in amounts that cause a film or sheen upon or discoloration of the waters of this Commonwealth or adjoining shoreline, or that exceed 15 mg/l as a daily average or 30 mg/l at any time (or lesser amounts if specified in this permit). (25 Pa. Code § 92a.47(a)(7), § 95.2(2))
 - c. Substances in concentration or amounts sufficient to be inimical or harmful to the water uses to be protected or to human, animal, plant or aquatic life. (25 Pa Code § 93.6(a))
 - d. Foam or substances that produce an observed change in the color, taste, odor or turbidity of the receiving water, unless those conditions are otherwise controlled through effluent limitations or other requirements in this permit. (25 Pa Code § 92a.41(c))
2. The monthly average percent removal of BOD₅ or CBOD₅ and TSS must be at least 85% for POTW facilities on a concentration basis except where 25 Pa. Code 92a.47(g) and (h) are applicable to facilities with combined sewer overflows (CSOs) or as otherwise specified in this permit. (25 Pa. Code § 92a.47(a)(3))
3. If the permit requires the reporting of average weekly statistical results, the maximum weekly average concentration and maximum weekly average mass loading shall be reported, regardless of whether the results are obtained for the same or different weeks.
4. The permittee shall monitor the sewage effluent discharge(s) for the effluent parameters identified in the Part A limitations table(s) during all bypass events at the facility, using the sample types that are specified in the limitations table(s). Where the required sample type is "composite", the permittee must commence sample collection within one hour of the start of the bypass, wherever possible. The results shall be reported on the Daily Effluent Monitoring supplemental form (3800-FM-BPNPSM0435) and be incorporated into the calculations used to report self-monitoring data on Discharge Monitoring Reports (DMRs).

Footnotes

- (1) When sampling to determine compliance with mass effluent limitations, the discharge flow at the time of sampling must be measured and recorded.
- (2) This is the minimum number of sampling events required. Permittees are encouraged, and it may be advantageous in demonstrating compliance, to perform more than the minimum number of sampling events.

Supplemental Information

- (1) The hydraulic design capacity of 0.16 million gallons per day for the treatment facility is used to prepare the annual Municipal Wasteload Management Report to help determine whether a "hydraulic overload" situation exists, as defined in Title 25 Pa. Code Chapter 94.
- (2) The effluent limitations for Outfall 001 were determined using an effluent discharge rate of 0.136 MGD.
- (3) The organic design capacity of 227 lbs BOD₅ per day for the treatment facility is used to prepare the annual Municipal Wasteload Management Report to determine whether an "organic overload" condition exists, as defined in 25 Pa. Code Chapter 94.
- (4) Total Nitrogen is the sum of Total Kjeldahl-N (TKN) plus Nitrite-Nitrate as N (NO₂+NO₃-N), where TKN and NO₂+NO₃-N are measured in the same sample.

II. DEFINITIONS

At Outfall (XXX) means a sampling location in outfall line XXX below the last point at which wastes are added to outfall line (XXX), or where otherwise specified.

Average refers to the use of an arithmetic mean, unless otherwise specified in this permit. (40 CFR 122.41(l)(4)(iii))

Best Management Practices (BMPs) means schedules of activities, prohibitions of practices, maintenance procedures and other management practices to prevent or reduce the pollutant loading to surface waters of the Commonwealth. The term also includes treatment requirements, operating procedures and practices to control plant site runoff, spillage or leaks, sludge or waste disposal, or drainage from raw material storage. The term includes activities, facilities, measures, planning or procedures used to minimize accelerated erosion and sedimentation and manage stormwater to protect, maintain, reclaim, and restore the quality of waters and the existing and designated uses of waters within this Commonwealth before, during and after earth disturbance activities. (25 Pa. Code § 92a.2)

Bypass means the intentional diversion of waste streams from any portion of a treatment facility. (40 CFR 122.41(m)(1)(i))

Calendar Week is defined as the seven consecutive days from Sunday through Saturday, unless the permittee has been given permission by DEP to provide weekly data as Monday through Friday based on showing excellent performance of the facility and a history of compliance. In cases when the week falls in two separate months, the month with the most days in that week shall be the month for reporting.

Clean Water Act means the Federal Water Pollution Control Act, as amended (33 U.S.C.A. §§ 1251 to 1387).

Composite Sample (for all except GC/MS volatile organic analysis) means a combination of individual samples (at least eight for a 24-hour period or four for an 8-hour period) of at least 100 milliliters (mL) each obtained at spaced time intervals during the compositing period. The composite must be flow-proportional; either the volume of each individual sample is proportional to discharge flow rates, or the sampling interval is proportional to the flow rates over the time period used to produce the composite. (EPA Form 2C)

Composite Sample (for GC/MS volatile organic analysis) consists of at least four aliquots or grab samples collected during the sampling event (not necessarily flow proportioned). The samples must be combined in the laboratory immediately before analysis and then one analysis is performed. (EPA Form 2C)

Daily Average Temperature means the average of all temperature measurements made, or the mean value plot of the record of a continuous automated temperature recording instrument, either during a calendar day or during the operating day if flows are of a shorter duration.

Daily Discharge means the discharge of a pollutant measured during a calendar day or any 24-hour period that reasonably represents the calendar day for purposes of sampling. For pollutants with limitations expressed in units of mass, the "daily discharge" is calculated as the total mass of the pollutant discharged over the day. For pollutants with limitations expressed in other units of measurement, the "daily discharge" is calculated as the average measurement of the pollutant over the day. (25 Pa. Code § 92a.2, 40 CFR 122.2)

Daily Maximum Discharge Limitation means the highest allowable "daily discharge."

Discharge Monitoring Report (DMR) means the DEP or EPA supplied form(s) for the reporting of self-monitoring results by the permittee. (25 Pa. Code § 92a.2, 40 CFR 122.2)

Estimated Flow means any method of liquid volume measurement based on a technical evaluation of the sources contributing to the discharge including, but not limited to, pump capabilities, water meters and batch discharge volumes.

Geometric Mean means the average of a set of n sample results given by the nth root of their product.

Grab Sample means an individual sample of at least 100 mL collected at a randomly selected time over a period not to exceed 15 minutes. (EPA Form 2C)

Hauled-In Wastes means any waste that is introduced into a treatment facility through any method other than a direct connection to the sewage collection system. The term includes wastes transported to and disposed of within the treatment facility or other entry points within the collection system.

Hazardous Substance means any substance designated under 40 CFR Part 116 pursuant to Section 311 of the Clean Water Act. (40 CFR 122.2)

Immersion Stabilization (i-s) means a calibrated device is immersed in the wastewater until the reading is stabilized.

Indirect Discharger means a non-domestic discharger introducing pollutants to a Publicly Owned Treatment Works (POTW) or other treatment works. (25 Pa. Code § 92a.2, 40 CFR 122.2)

Industrial User means a source of Indirect Discharge. (40 CFR 403.3)

Instantaneous Maximum Effluent Limitation means the highest allowable discharge of a concentration or mass of a substance at any one time as measured by a grab sample. (25 Pa. Code § 92a.2)

Measured Flow means any method of liquid volume measurement, the accuracy of which has been previously demonstrated in engineering practice, or for which a relationship to absolute volume has been obtained.

Monthly Average Discharge Limitation means the highest allowable average of "daily discharges" over a calendar month, calculated as the sum of all "daily discharges" measured during a calendar month divided by the number of "daily discharges" measured during that month. (25 Pa. Code § 92a.2)

Municipality means a city, town, borough, county, township, school district, institution, authority or other public body created by or pursuant to State law and having jurisdiction over disposal of sewage, industrial wastes, or other wastes. (25 Pa. Code § 92a.2)

Municipal Waste means garbage, refuse, industrial lunchroom or office waste and other material, including solid, liquid, semisolid or contained gaseous material resulting from operation of residential, municipal, commercial or institutional establishments and from community activities; and sludge not meeting the definition of residual or hazardous waste under this section from a municipal, commercial or institutional water supply treatment plant, waste water treatment plant or air pollution control facility. (25 Pa. Code § 271.1)

Publicly Owned Treatment Works (POTW) means a treatment works as defined by §212 of the Clean Water Act, owned by a state or municipality. The term includes any devices and systems used in the storage, treatment, recycling and reclamation of municipal sewage or industrial wastes of a liquid nature. The term also includes sewers, pipes or other conveyances if they convey wastewater to a POTW providing treatment. The term also means the municipality as defined in section 502(4) of the Clean Water Act, which has jurisdiction over the indirect discharges to and the discharges from such a treatment works. (25 Pa Code § 92a.2, 40 CFR 122.2)

Residual Waste means garbage, refuse, other discarded material or other waste, including solid, liquid, semisolid or contained gaseous materials resulting from industrial, mining and agricultural operations and sludge from an industrial, mining or agricultural water supply treatment facility, wastewater treatment facility or air pollution control facility, if it is not hazardous. The term does not include coal refuse as defined in the Coal Refuse Disposal Control Act. The term does not include treatment sludges from coal mine drainage treatment plants, disposal of which is being carried on under and in compliance with a valid permit issued under the Clean Streams Law. (25 Pa Code § 287.1)

Severe Property Damage means substantial physical damage to property, damage to the treatment facilities that causes them to become inoperable, or substantial and permanent loss of natural resources that can reasonably be expected to occur in the absence of a bypass. Severe property damage does not mean economic loss caused by delays in production. (40 CFR 122.41(m)(1)(ii))

Stormwater means the runoff from precipitation, snow melt runoff, and surface runoff and drainage. (25 Pa. Code § 92a.2)

Stormwater Associated With Industrial Activity means the discharge from any conveyance that is used for collecting and conveying stormwater and that is directly related to manufacturing, processing or raw materials storage areas at an industrial plant, and as defined at 40 CFR §122.26(b)(14)(i) – (ix) and (xi) and 25 Pa. Code § 92a.2.

Toxic Pollutant means those pollutants, or combinations of pollutants, including disease-causing agents, which after discharge and upon exposure, ingestion, inhalation or assimilation into any organism, either directly from the environment or indirectly by ingestion through food chains may, on the basis of information available to DEP cause death, disease, behavioral abnormalities, cancer, genetic mutations, physiological malfunctions, including malfunctions in reproduction, or physical deformations in these organisms or their offspring. (25 Pa. Code § 92a.2)

Weekly Average Discharge Limitation means the highest allowable average of "daily discharges" over a calendar week, calculated as the sum of all "daily discharges" measured during a calendar week divided by the number of "daily discharges" measured during that week.

III. SELF-MONITORING, REPORTING AND RECORDKEEPING

A. Representative Sampling

1. Samples and measurements taken for the purpose of monitoring shall be representative of the monitored activity (40 CFR 122.41(j)(1)). Representative sampling includes the collection of samples, where possible, during periods of adverse weather, changes in treatment plant performance and changes in treatment plant loading. If possible, effluent samples must be collected where the effluent is well mixed near the center of the discharge conveyance and at the approximate mid-depth point, where the turbulence is at a maximum and the settlement of solids is minimized. (40 CFR 122.48, 25 Pa. Code § 92a.61)

2. Records Retention (40 CFR 122.41(j)(2))

Except for records of monitoring information required by this permit related to the permittee's sludge use and disposal activities which shall be retained for a period of at least 5 years, all records of monitoring activities and results (including all original strip chart recordings for continuous monitoring instrumentation and calibration and maintenance records), copies of all reports required by this permit, and records of all data used to complete the application for this permit shall be retained by the permittee for 3 years from the date of the sample measurement, report or application, unless a longer retention period is required by the permit. The 3-year period shall be extended as requested by DEP or the EPA Regional Administrator.

3. Recording of Results (40 CFR 122.41(j)(3))

For each measurement or sample taken pursuant to the requirements of this permit, the permittee shall record the following information:

- a. The exact place, date and time of sampling or measurements.
- b. The person(s) who performed the sampling or measurements.
- c. The date(s) the analyses were performed.
- d. The person(s) who performed the analyses.
- e. The analytical techniques or methods used; and the associated detection level.
- f. The results of such analyses.

4. Test Procedures

- a. Facilities that test or analyze environmental samples used to demonstrate compliance with this permit shall be in compliance with laboratory accreditation requirements of Act 90 of 2002 (27 Pa. C.S. §§ 4101-4113) and 25 Pa. Code Chapter 252, relating to environmental laboratory accreditation.

- b. Test procedures (methods) for the analysis of pollutants or pollutant parameters shall be those approved under 40 CFR Part 136 or required under 40 CFR Chapter I, Subchapters N or O, unless the method is specified in this permit or has been otherwise approved in writing by DEP. (40 CFR 122.41(j)(4), 122.44(i)(1)(iv))

- c. Test procedures (methods) for the analysis of pollutants or pollutant parameters shall be sufficiently sensitive. A method is sufficiently sensitive when 1) the method minimum level is at or below the level of the effluent limit established in the permit for the measured pollutant or pollutant parameter; or 2) the method has the lowest minimum level of the analytical methods approved under 40 CFR Part 136 or required under 40 CFR Chapter I, Subchapters N or O, for the measured pollutant or pollutant parameter; or 3) the method is specified in this permit or has been otherwise approved in writing by DEP for the measured pollutant or pollutant parameter. Permittees have the option of providing matrix or sample-specific minimum levels rather than the published levels. (40 CFR 122.44(i)(1)(iv))

5. Quality/Assurance/Control

In an effort to assure accurate self-monitoring analyses results:

- a. The permittee, or its designated laboratory, shall participate in the periodic scheduled quality assurance inspections conducted by DEP and EPA. (40 CFR 122.41(e), 122.41(i)(3))
- b. The permittee, or its designated laboratory, shall develop and implement a program to assure the quality and accurateness of the analyses performed to satisfy the requirements of this permit, in accordance with 40 CFR Part 136. (40 CFR 122.41(j)(4))

B. Reporting of Monitoring Results

1. The permittee shall effectively monitor the operation and efficiency of all wastewater treatment and control facilities, and the quantity and quality of the discharge(s) as specified in this permit. (40 CFR 122.41(e), 122.44(i)(1))
2. Discharge Monitoring Reports (DMRs) must be completed in accordance with DEP's published DMR Instructions (3800-FM-BPNPSM0463). DMRs are based on calendar reporting periods unless Part C of this permit requires otherwise. DMR(s) must be received by the agency(ies) specified in paragraph 3 below in accordance with the following schedule:
 - Monthly DMRs must be received within 28 days following the end of each calendar month.
 - Quarterly DMRs must be received within 28 days following the end of each calendar quarter, i.e., January 28, April 28, July 28, and October 28.
 - Semiannual DMRs must be received within 28 days following the end of each calendar semiannual period, i.e., January 28 and July 28.
 - Annual DMRs must be received by January 28, unless Part C of this permit requires otherwise.
3. The permittee shall complete all Supplemental Reporting forms (Supplemental DMRs) provided by DEP in this permit (or an approved equivalent), and submit the signed, completed forms as an attachment to the DMR(s). If the permittee elects to use DEP's electronic DMR (eDMR) system, one electronic submission may be made for DMRs and Supplemental DMRs. If paper forms are used, the completed forms shall be mailed to:

Department of Environmental Protection
Clean Water Program
208 West Third Street, Suite 101
Williamsport, PA 17701-6448
4. If the permittee elects to begin using DEP's eDMR system to submit DMRs required by the permit, the permittee shall, to assure continuity of business operations, continue using the eDMR system to submit all DMRs and Supplemental Reports required by the permit, unless the following steps are completed to discontinue use of eDMR:
 - a. The permittee shall submit written notification to the regional office that issued the permit that it intends to discontinue use of eDMR. The notification shall be signed by a principal executive officer or authorized agent of the permittee.
 - b. The permittee shall continue using eDMR until the permittee receives written notification from DEP's Central Office that the facility has been removed from the eDMR system, and electronic report submissions are no longer expected.
5. The completed DMR Form shall be signed and certified by either of the following applicable persons, as defined in 25 Pa. Code § 92a.22:

- For a corporation - by a principal executive officer of at least the level of vice president, or an authorized representative, if the representative is responsible for the overall operation of the facility from which the discharge described in the NPDES form originates.
- For a partnership or sole proprietorship - by a general partner or the proprietor, respectively.
- For a municipality, state, federal or other public agency - by a principal executive officer or ranking elected official.

If signed by a person other than the above, written notification of delegation of DMR signatory authority must be submitted to DEP in advance of or along with the relevant DMR form. (40 CFR 122.22(b))

6. If the permittee monitors any pollutant at monitoring points as designated by this permit, using analytical methods described in Part A III.A.4. herein, more frequently than the permit requires, the results of this monitoring shall be incorporated, as appropriate, into the calculations used to report self-monitoring data on the DMR. (40 CFR 122.41(l)(4)(ii))

C. Reporting and Notification Requirements

1. Planned Changes to Physical Facilities – The permittee shall give notice to DEP as soon as possible but no later than 30 days prior to planned physical alterations or additions to the permitted facility. A permit under 25 Pa. Code Chapter 91 may be required for these situations prior to implementing the planned changes. A permit application, or other written submission to DEP, can be used to satisfy the notification requirements of this section.

Notice is required when:

- a. The alteration or addition to a permitted facility may meet one of the criteria for determining whether a facility is a new source in 40 CFR 122.29(b). (40 CFR 122.41(l)(1)(i))
 - b. The alteration or addition could significantly change the nature or increase the quantity of pollutants discharged. This notification applies to pollutants which are not subject to effluent limitations in this permit. (40 CFR 122.41(l)(1)(ii))
 - c. The alteration or addition results in a significant change in the permittee's sludge use or disposal practices, and such alteration, addition, or change may justify the application of permit conditions that are different from or absent in the existing permit, including notification of additional use or disposal sites not reported during the permit application process or not reported pursuant to an approved land application plan. (40 CFR 122.41(l)(1)(iii))
 - d. The planned change may result in noncompliance with permit requirements. (40 CFR 122.41(l)(2))
2. Planned Changes to Waste Stream – Under the authority of 25 Pa. Code § 92a.24(a) and 40 CFR 122.42(b), the permittee shall provide notice to DEP and EPA as soon as possible but no later than 45 days prior to any planned changes in the volume or pollutant concentration of its influent waste stream as a result of indirect discharges or hauled-in wastes, as specified in paragraphs 2.a. and 2.b., below. Notice shall be provided on the "Planned Changes to Waste Stream" Supplemental Report (3800-FM-BPNPSM0482), available on DEP's website. The permittee shall provide information on the quality and quantity of waste introduced into the POTW, and any anticipated impact of the change on the quantity or quality of effluent to be discharged from the POTW (40 CFR 122.42(b)(3)). The Report shall be sent via Certified Mail or other means to confirm DEP's receipt of the notification. DEP will determine if the submission of a new application and receipt of a new or amended permit is required.
 - a. Introduction of New Pollutants (25 Pa. Code § 92a.24(a), 40 CFR 122.42(b)(1))

New pollutants are defined as parameters that meet one or more of the following criteria:

- (i) Any pollutants that were not detected in the facilities' influent waste stream as reported in the permit application; and have not been approved to be included in the permittee's influent waste stream by DEP in writing.

- (ii) Any new introduction of pollutants into the POTW from an indirect discharger which would be subject to Sections 301 or 306 of the Clean Water Act if it were directly discharging those pollutants (40 CFR 122.42(b)(1)).

The permittee shall provide notification of the introduction of new pollutants in accordance with paragraph 2 above. The permittee may not authorize the introduction of new pollutants until the permittee receives DEP's written approval.

- b. Increased Loading of Approved Pollutants (25 Pa. Code § 92a.24(a), 40 CFR 122.42(b)(2))

Approved pollutants are defined as parameters that meet one or more of the following criteria:

- (i) Were detected in the facilities' influent waste stream as reported in the permittee's permit application; or have been previously approved to be included in the permittee's influent waste stream by DEP in writing.
- (ii) Have an effluent limitation or monitoring requirement in this permit.

The permittee shall provide notification of the introduction of increased influent loading (lbs/day) of approved pollutants in accordance with paragraph 2 above when (1) the cumulative increase in influent loading (lbs/day) exceeds 20% of the maximum loading reported in the permit application, or a loading previously approved by DEP and/or EPA, or (2) may cause an exceedance in the effluent of Effluent Limitation Guidelines (ELGs) or limitations in Part A of this permit, or (3) may cause interference or pass through at the POTW, or (4) may cause exceedances of the applicable water quality standards in the receiving stream. Unless specified otherwise in this permit, if DEP does not respond to the notification within 30 days of its receipt, the permittee may proceed with the increase in loading. The acceptance of increased loading of approved pollutants may not result in an exceedance of ELGs or effluent limitations, may not result in a hydraulic or organic overload condition as defined in 25 Pa. Code § 94.1, and may not cause exceedances of the applicable water quality standards in the receiving stream.

3. Reporting Requirements for Hauled-In Wastes

a. Receipt of Residual Waste

- (i) The permittee shall document the receipt of all hauled-in residual wastes (including but not limited to wastewater from oil and gas wells, food processing waste, and landfill leachate), as defined at 25 Pa. Code § 287.1, that are received for processing at the treatment facility. The permittee shall report hauled-in residual wastes on a monthly basis to DEP on the "Hauled In Residual Wastes" Supplemental Report (3800-FM-BPNPSM0450) as an attachment to the DMR. If no residual wastes were received during a month, submission of the Supplemental Report is not required.

The following information is required by the Supplemental Report. The information used to develop the Report shall be retained by the permittee for five years from the date of receipt and must be made available to DEP or EPA upon request.

- (1) The dates that residual wastes were received.
- (2) The volume (gallons) of wastes received.
- (3) The license plate number of the vehicle transporting the waste to the treatment facility.
- (4) The permit number(s) of the well(s) where residual wastes were generated, if applicable.
- (5) The name and address of the generator of the residual wastes.

- (6) The type of wastewater.

The transporter of residual waste must maintain these and other records as part of the daily operational record (25 Pa. Code § 299.219). If the transporter is unable to provide this information or the permittee has not otherwise received the information from the generator, the residual wastes shall not be accepted by the permittee until such time as the permittee receives such information from the transporter or generator.

- (ii) The following conditions apply to the characterization of residual wastes received by the permittee:
- (1) If the generator is required to complete a chemical analysis of residual wastes in accordance with 25 Pa. Code § 287.51, the permittee must receive and maintain on file a chemical analysis of the residual wastes it receives. The chemical analysis must conform to the Bureau of Waste Management's Form 26R except as noted in paragraph (2), below. Each load of residual waste received must be covered by a chemical analysis if the generator is required to complete it.
 - (2) For wastewater generated from hydraulic fracturing operations ("frac wastewater") within the first 30 production days of a well site, the chemical analysis may be a general frac wastewater characterization approved by DEP. Thereafter, the chemical analysis must be waste-specific and be reported on the Form 26R.

b. Receipt of Municipal Waste

- (i) The permittee shall document the receipt of all hauled-in municipal wastes (including but not limited to septage and liquid sewage sludge), as defined at 25 Pa. Code § 271.1, that are received for processing at the treatment facility. The permittee shall report hauled-in municipal wastes on a monthly basis to DEP on the "Hauled In Municipal Wastes" Supplemental Report (3800-FM-BPNPSM0437) as an attachment to the DMR. If no municipal wastes were received during a month, submission of the Supplemental Report is not required.

The following information is required by the Supplemental Report:

- (1) The dates that municipal wastes were received.
 - (2) The volume (gallons) of wastes received.
 - (3) The BOD₅ concentration (mg/l) and load (lbs) for the wastes received.
 - (4) The location(s) where wastes were disposed of within the treatment facility.
- (ii) Sampling and analysis of hauled-in municipal wastes must be completed to characterize the organic strength of the wastes, unless composite sampling of influent wastewater is performed at a location downstream of the point of entry for the wastes. The influent BOD₅ characterization for the treatment facility, as reported in the annual Municipal Wasteload Management Report per 25 Pa. Code Chapter 94, must be representative of the hauled-in municipal wastes received.

4. Unanticipated Noncompliance or Potential Pollution Reporting

- a. Immediate Reporting - The permittee shall immediately report any incident causing or threatening pollution in accordance with the requirements of 25 Pa. Code §§ 91.33 and 92a.41(b).
- (i) If, because of an accident, other activity or incident a toxic substance or another substance which would endanger users downstream from the discharge, or would otherwise result in pollution or create a danger of pollution or would damage property, the permittee shall immediately notify DEP by telephone of the location and nature of the danger. Oral notification to the Department is required as soon as possible, but no later than 4 hours after the permittee becomes aware of the incident causing or threatening pollution.
 - (ii) If reasonably possible to do so, the permittee shall immediately notify downstream users of the waters of the Commonwealth to which the substance was discharged. Such notice shall include the location and nature of the danger.
 - (iii) The permittee shall immediately take or cause to be taken steps necessary to prevent injury to property and downstream users of the waters from pollution or a danger of pollution and, in addition, within 15 days from the incident, shall remove the residual substances contained thereon or therein from the ground and from the affected waters of this Commonwealth to the extent required by applicable law.
- b. The permittee shall report any noncompliance which may endanger health or the environment in accordance with the requirements of 40 CFR 122.41(l)(6). These requirements include the following obligations:
- (i) 24 Hour Reporting - The permittee shall orally report any noncompliance with this permit which may endanger health or the environment within 24 hours from the time the permittee becomes aware of the circumstances. The following shall be included as information which must be reported within 24 hours under this paragraph (40 CFR 122.41(l)(6)(ii)):
 - (1) Any unanticipated bypass which exceeds any effluent limitation in the permit;
 - (2) Any upset which exceeds any effluent limitation in the permit; and
 - (3) Violation of the maximum daily discharge limitation for any of the pollutants listed in the permit as being subject to the 24-hour reporting requirement.
 - (ii) Written Report - A written submission shall also be provided within 5 days of the time the permittee becomes aware of any noncompliance which may endanger health or the environment. The written submission shall contain a description of the noncompliance and its cause; the period of noncompliance, including exact dates and times, and if the noncompliance has not been corrected, the anticipated time it is expected to continue; and steps taken or planned to reduce, eliminate, and prevent reoccurrence of the noncompliance.
 - (iii) Waiver of Written Report - DEP may waive the written report on a case-by-case basis if the associated oral report has been received within 24 hours from the time the permittee becomes aware of the circumstances which may endanger health or the environment. Unless such a waiver is expressly granted by DEP, the permittee shall submit a written report in accordance with this paragraph. (40 CFR 122.41(l)(6)(iii))

5. Other Noncompliance

The permittee shall report all instances of noncompliance not reported under paragraph C.4 of this section or specific requirements of compliance schedules, at the time DMRs are submitted, on the Non-Compliance Reporting Form (3800-FM-BPNPSM0440). The reports shall contain the information listed in paragraph C.4.b.(ii) of this section. (40 CFR 122.41(l)(7))

PART B

I. MANAGEMENT REQUIREMENTS

A. Compliance

1. The permittee shall comply with all conditions of this permit. If a compliance schedule has been established in this permit, the permittee shall achieve compliance with the terms and conditions of this permit within the time frames specified in this permit. (40 CFR 122.41(a)(1))
2. The permittee shall submit reports of compliance or noncompliance, or progress reports as applicable, for any interim and final requirements contained in this permit. Such reports shall be submitted no later than 14 days following the applicable schedule date or compliance deadline. (25 Pa. Code § 92a.51(c), 40 CFR 122.47(a)(4))

B. Permit Modification, Termination, or Revocation and Reissuance

1. This permit may be modified, terminated, or revoked and reissued during its term in accordance with 25 Pa. Code § 92a.72 and 40 CFR 122.41(f).
2. The filing of a request by the permittee for a permit modification, revocation and reissuance, or termination, or a notification of planned changes or anticipated noncompliance, does not stay any permit condition. (40 CFR 122.41(f))
3. In the absence of DEP action to modify or revoke and reissue this permit, the permittee shall comply with effluent standards or prohibitions established under Section 307(a) of the Clean Water Act for toxic pollutants within the time specified in the regulations that establish those standards or prohibitions. (40 CFR 122.41(a)(1))

C. Duty to Provide Information

1. The permittee shall furnish to DEP, within a reasonable time, any information which DEP may request to determine whether cause exists for modifying, revoking and reissuing, or terminating this permit, or to determine compliance with this permit. (40 CFR 122.41(h))
2. The permittee shall furnish to DEP, upon request, copies of records required to be kept by this permit. (40 CFR 122.41(h))
3. Other Information - Where the permittee becomes aware that it failed to submit any relevant facts in a permit application, or submitted incorrect information in a permit application or in any report to DEP, it shall promptly submit the correct and complete facts or information. (40 CFR 122.41(l)(8))
4. The permittee shall provide the following information in the annual Municipal Wasteload Management Report, required under the provisions of Title 25 Pa. Code Chapter 94:
 - a. The requirements identified in 25 Pa. Code § 94.12.
 - b. The identity of any indirect discharger(s) served by the POTW which are subject to pretreatment standards adopted under Section 307(b) of the Clean Water Act; the POTW shall also specify the total volume of discharge and estimated concentration of each pollutant discharged into the POTW by the indirect discharger.
 - c. A "Solids Management Inventory" if specified in Part C of this permit.
 - d. The total volume of hauled-in residual and municipal wastes received during the year, by source.
 - e. The Annual Report requirements for permittees required to implement an industrial pretreatment program listed in Part C, as applicable.

D. General Pretreatment Requirements

1. Any POTW (or combination of POTWs operated by the same authority) with a total design flow greater than 5 million gallons per day (MGD) and receiving from industrial users pollutants which pass through or interfere with the operation of the POTW or are otherwise subject to Pretreatment Standards will be required to establish a POTW Pretreatment Program unless specifically exempted by the Approval Authority. A POTW with a design flow of 5 MGD or less may be required to develop a POTW Pretreatment Program if the Approval Authority finds that the nature or volume of the industrial influent, treatment process upsets, violations of effluent limitations, contamination of sludge, or other circumstances warrant in order to prevent interference or pass through. (40 CFR 403.8)
2. Each POTW with an approved Pretreatment Program pursuant to 40 CFR 403.8 shall develop and enforce specific limits to implement the prohibitions listed in 40 CFR 403.5(a)(1) and (b), and shall continue to develop these limits as necessary and effectively enforce such limits. This condition applies, for example, when there are planned changes to the waste stream as identified in Part A III.C.2. If the permittee is required to develop or continue implementation of a Pretreatment Program, detailed requirements will be contained in Part C of this permit.
3. For all POTWs, where pollutants contributed by indirect dischargers result in interference or pass through, and a violation is likely to recur, the permittee shall develop and enforce specific limits for indirect dischargers and other users, as appropriate, that together with appropriate facility or operational changes, are necessary to ensure renewed or continued compliance with this permit or sludge use or disposal practices. Where POTWs do not have an approved Pretreatment Program, the permittee shall submit a copy of such limits to DEP when developed. (25 Pa. Code § 92a.47(d))

E. Proper Operation and Maintenance

1. The permittee shall employ operators certified in compliance with the Water and Wastewater Systems Operators Certification Act (63 P.S. §§ 1001-1015.1).
2. The permittee shall at all times properly operate and maintain all facilities and systems of treatment and control (and related appurtenances) which are installed or used by the permittee to achieve compliance with the terms and conditions of this permit. Proper operation and maintenance includes, but is not limited to, adequate laboratory controls including appropriate quality assurance procedures. This provision also includes the operation of backup or auxiliary facilities or similar systems that are installed by the permittee, only when necessary to achieve compliance with the terms and conditions of this permit. (40 CFR 122.41(e))

F. Duty to Mitigate

The permittee shall take all reasonable steps to minimize or prevent any discharge, sludge use or disposal in violation of this permit that has a reasonable likelihood of adversely affecting human health or the environment. (40 CFR 122.41(d))

G. Bypassing

1. Bypassing Not Exceeding Permit Limitations - The permittee may allow a bypass to occur which does not cause effluent limitations to be exceeded, but only if it also is for essential maintenance to assure efficient operation. These bypasses are not subject to the provisions in paragraphs two, three and four of this section. (40 CFR 122.41(m)(2))
2. Other Bypassing - In all other situations, bypassing is prohibited and DEP may take enforcement action against the permittee for bypass unless:
 - a. A bypass is unavoidable to prevent loss of life, personal injury or "severe property damage." (40 CFR 122.41(m)(4)(i)(A))

- b. There are no feasible alternatives to the bypass, such as the use of auxiliary treatment facilities, retention of untreated wastes, or maintenance during normal periods of equipment downtime. This condition is not satisfied if adequate backup equipment should have been installed in the exercise of reasonable engineering judgment to prevent a bypass which occurred during normal periods of equipment downtime or preventive maintenance. (40 CFR 122.41(m)(4)(i)(B))
 - c. The permittee submitted the necessary notice required in paragraph G.4 below. (40 CFR 122.41(m)(4)(i)(C))
3. DEP may approve an anticipated bypass, after considering its adverse effects, if DEP determines that it will meet the conditions listed in paragraph G.2 above. (40 CFR 122.41(m)(4)(ii))
 4. Notice
 - a. Anticipated Bypass – If the permittee knows in advance of the need for a bypass, it shall submit prior notice, if possible, at least 10 days before the bypass. (40 CFR 122.41(m)(3)(i))
 - b. Unanticipated Bypass – The permittee shall submit oral notice of any other unanticipated bypass within 24 hours, regardless of whether the bypass may endanger health or the environment or whether the bypass exceeds effluent limitations. The notice shall be in accordance with Part A III.C.4.b.

H. Sanitary Sewer Overflows (SSOs)

An SSO is an overflow of wastewater, or other untreated discharge from a separate sanitary sewer system (which is not a combined sewer system), which results from a flow in excess of the carrying capacity of the system or from some other cause prior to reaching the headworks of the sewage treatment facility. SSOs are not authorized under this permit. The permittee shall immediately report any SSO to DEP in accordance with Part A III.C.4 of this permit.

II. PENALTIES AND LIABILITY

A. Violations of Permit Conditions

Any person violating Sections 301, 302, 306, 307, 308, 318 or 405 of the Clean Water Act or any permit condition or limitation implementing such sections in a permit issued under Section 402 of the Act is subject to civil, administrative and/or criminal penalties as set forth in 40 CFR 122.41(a)(2).

Any person or municipality, who violates any provision of this permit; any rule, regulation or order of DEP; or any condition or limitation of any permit issued pursuant to the Clean Streams Law, is subject to criminal and/or civil penalties as set forth in Sections 602, 603 and 605 of the Clean Streams Law.

B. Falsifying Information

Any person who does any of the following:

- Falsifies, tampers with, or knowingly renders inaccurate any monitoring device or method required to be maintained under this permit, or
- Knowingly makes any false statement, representation, or certification in any record or other document submitted or required to be maintained under this permit (including monitoring reports or reports of compliance or noncompliance)

Shall, upon conviction, be punished by a fine and/or imprisonment as set forth in 18 Pa.C.S.A § 4904 and 40 CFR 122.41(j)(5) and (k)(2).

C. Liability

Nothing in this permit shall be construed to relieve the permittee from civil or criminal penalties for noncompliance pursuant to Section 309 of the Clean Water Act or Sections 602, 603 or 605 of the Clean Streams Law.

Nothing in this permit shall be construed to preclude the institution of any legal action or to relieve the permittee from any responsibilities, liabilities or penalties to which the permittee is or may be subject to under the Clean Water Act and the Clean Streams Law.

D. Need to Halt or Reduce Activity Not a Defense

It shall not be a defense for the permittee in an enforcement action that it would have been necessary to halt or reduce the permitted activity in order to maintain compliance with the conditions of this permit. (40 CFR 122.41(c))

III. OTHER RESPONSIBILITIES

A. Right of Entry

Pursuant to Sections 5(b) and 305 of Pennsylvania's Clean Streams Law, and Title 25 Pa. Code Chapter 92a and 40 CFR 122.41(i), the permittee shall allow authorized representatives of DEP and EPA, upon the presentation of credentials and other documents as may be required by law:

1. To enter upon the permittee's premises where a regulated facility or activity is located or conducted, or where records must be kept under the conditions of this permit; (40 CFR 122.41(i)(1))
2. To have access to and copy, at reasonable times, any records that must be kept under the conditions of this permit; (40 CFR 122.41(i)(2))
3. To inspect at reasonable times any facilities, equipment (including monitoring and control equipment), practices or operations regulated or required under this permit; and (40 CFR 122.41(i)(3))
4. To sample or monitor at reasonable times, for the purposes of assuring permit compliance or as otherwise authorized by the Clean Water Act or the Clean Streams Law, any substances or parameters at any location. (40 CFR 122.41(i)(4))

B. Transfer of Permits

1. Transfers by modification. Except as provided in paragraph 2 of this section, a permit may be transferred by the permittee to a new owner or operator only if this permit has been modified or revoked and reissued, or a minor modification made to identify the new permittee and incorporate such other requirements as may be necessary under the Clean Water Act. (40 CFR 122.61(a))
2. Automatic transfers. As an alternative to transfers under paragraph 1 of this section, any NPDES permit may be automatically transferred to a new permittee if:
 - a. The current permittee notifies DEP at least 30 days in advance of the proposed transfer date in paragraph 2.b. of this section; (40 CFR 122.61(b)(1))
 - b. The notice includes the appropriate DEP transfer form signed by the existing and new permittees containing a specific date for transfer of permit responsibility, coverage and liability between them; and (40 CFR 122.61(b)(2))
 - c. DEP does not notify the existing permittee and the proposed new permittee of its intent to modify or revoke and reissue this permit, the transfer is effective on the date specified in the agreement mentioned in paragraph 2.b. of this section. (40 CFR 122.61(b)(3))
 - d. The new permittee is in compliance with existing DEP issued permits, regulations, orders and schedules of compliance, or has demonstrated that any noncompliance with the existing permits

has been resolved by an appropriate compliance action or by the terms and conditions of the permit (including compliance schedules set forth in the permit), consistent with 25 Pa. Code § 92a.51 (relating to schedules of compliance) and other appropriate Department regulations. (25 Pa. Code § 92a.71)

3. In the event DEP does not approve transfer of this permit, the new owner or operator must submit a new permit application.

C. Property Rights

The issuance of this permit does not convey any property rights of any sort, or any exclusive privilege. (40 CFR 122.41(g))

D. Duty to Reapply

If the permittee wishes to continue an activity regulated by this permit after the expiration date of this permit, the permittee must apply for a new permit. (40 CFR 122.41(b))

E. Other Laws

The issuance of this permit does not authorize any injury to persons or property or invasion of other private rights, or any infringement of state or local law or regulations.

IV. ANNUAL FEE

Permittees shall pay an annual fee in accordance with 25 Pa. Code § 92a.62. Annual fee amounts are specified in the following schedule and are due on each anniversary of the effective date of the most recent new or reissued permit. All flows identified in the schedule are annual average design flows. (25 Pa. Code § 92a.62)

Small Flow Treatment Facility (SRSTP and SFTF)	\$0
Minor Sewage Facility < 0.05 MGD (million gallons per day)	\$250
Minor Sewage Facility ≥ 0.05 and < 1 MGD	\$500
Minor Sewage Facility with CSO (Combined Sewer Overflow)	\$750
Major Sewage Facility ≥ 1 and < 5 MGD	\$1,250
Major Sewage Facility ≥ 5 MGD	\$2,500
Major Sewage Facility with CSO	\$5,000

As of the effective date of this permit, the facility covered by the permit is classified in the following fee category: **Minor Sewage Facility ≥0.05 and <1 MGD.**

Invoices for annual fees will be mailed to permittees approximately three months prior to the due date. In the event that an invoice is not received, the permittee is nonetheless responsible for payment. Throughout a five year permit term, permittees will pay four annual fees followed by a permit renewal application fee in the last year of permit coverage. Permittees may contact the DEP at 717-787-6744 with questions related to annual fees. The fees identified above are subject to change in accordance with 25 Pa. Code § 92a.62(e).

Payment for annual fees shall be remitted to DEP at the address below by the anniversary date. Checks should be made payable to the Commonwealth of Pennsylvania.

PA Department of Environmental Protection
Bureau of Point and Non-Point Source Management
Re: Chapter 92a Annual Fee
P.O. Box 8466
Harrisburg, PA 17105-8466

PART C

I. OTHER REQUIREMENTS

- A. No storm water from pavements, area ways, roofs, foundation drains or other sources shall be directly admitted to the sanitary sewers associated with the herein approved discharge.
- B. The approval herein given is specifically made contingent upon the permittee acquiring all necessary property rights by easement or otherwise, providing for the satisfactory construction, operation, maintenance or replacement of all sewers or sewerage structures associated with the herein approved discharge in, along, or across private property, with full rights of ingress, egress and regress.
- C. Collected screenings, slurries, sludges, and other solids shall be handled and disposed of in compliance with 25 Pa. Code, Chapters 271, 273, 275, 283, and 285 (related to permits and requirements for landfilling, land application, incineration, and storage of sewage sludge), Federal Regulation 40 CFR 257, Pennsylvania Clean Streams Law, Pennsylvania Solid Waste Management Act of 1980, and the Federal Clean Water Act and its amendments. The permittee is responsible to obtain or assure that contracted agents have all necessary permits and approvals for the handling, storage, transport, and disposal of solid waste materials generated as a result of wastewater treatment.
- D. The permittee shall optimize chlorine dosages used for disinfection or other purposes to minimize the concentration of Total Residual Chlorine (TRC) in the effluent, meet applicable effluent limitations, and reduce the possibility of adversely affecting the receiving waters. Optimization efforts may include an evaluation of wastewater characteristics, mixing characteristics, and contact times, adjustments to process controls, and maintenance of the disinfection facilities. If DEP determines that effluent TRC is causing adverse water quality impacts, DEP may reopen this permit to apply new or more stringent effluent limitations and/or require implementation of control measures or operational practices to eliminate such impacts.

Where the permittee does not use chlorine for primary or backup disinfection, but proposes the use of chlorine for cleaning or other purposes, the permittee shall notify DEP prior to initiating use of chlorine and monitor TRC concentrations in the effluent on each day in which chlorine is used. The results shall be submitted as an attachment to the DMR.

II. SOLIDS MANAGEMENT

- A. The permittee shall manage and properly dispose of sewage sludge and/or biosolids, produced by the system, by balancing the amount of solids maintained within the treatment system. The permittee shall develop a scheduled sludge wasting rate that maintains an appropriate mass balance for the specific treatment process type and system loadings and maintains compliance with permit effluent conditions. Holding excess sludge within clarifiers or in the disinfection process is not acceptable. The permittee shall compute and set the wasting rate and time so as to maintain an appropriate balance of sludge in the system. Seasonal variations shall be considered in developing sludge wasting rates.
- B. The permittee shall submit the Supplemental Reports entitled, "Supplemental Report – Sewage Sludge/Biosolids Production and Disposal" (Form No. 3800-FM-BPNPSM0438) and "Supplemental Report – Influent & Process Control" (Form No. 3800-FM-BPNPSM0436), as attachments to the DMR on a monthly basis. When applicable, the permittee shall submit the Supplemental Reports entitled, "Supplemental Report – Hauled In Municipal Wastes" (Form No. 3800-FM-BPNPSM0437) and "Supplemental Report – Hauled In Residual Wastes" (Form No. 3800-FM-BPNPSM0450), as attachments to the DMR.
- C. By March 31 of each year, the permittee shall submit a "Sewage Sludge Management Inventory" that summarizes the amount of sewage sludge and/or biosolids produced and wasted during the calendar year from the system. The "Sewage Sludge Management Inventory" may be submitted with the Municipal Wasteload Management Report required by Chapter 94. This summary shall include the expected sewage sludge production (estimated using the methodology described in the U.S. EPA handbook, "Improving POTW Performance Using the Composite Correction Approach" (EPA-625/6-84-008)), compared with the

actual amount disposed during the year. Sludge quantities shall be expressed as dry weight in addition to gallons or other appropriate units.

III. SCHEDULE OF COMPLIANCE

A. The permittee shall achieve compliance with final effluent limitations or terminate this discharge in accordance with the following schedule:

- | | |
|---|------------------------|
| 1. Final design completion | <u>October 1, 2016</u> |
| 2. Obtain all necessary permits | <u>June 1, 2017</u> |
| 3. Complete construction and compliance with effluent limitations | <u>June 1, 2018</u> |

B. No later than 14 calendar days following a date identified in the above schedule of compliance, the permittee shall submit to DEP a written notice of compliance or non-compliance with the specific schedule requirement. Each notice of non-compliance shall include the following information:

1. A short description of the non-compliance.
2. A description of any actions taken or proposed by the permittee to comply with the elapsed schedule requirement.
3. A description of any factors which tend to explain or mitigate the non-compliance.
4. An estimate of the date that compliance with the elapsed schedule requirement will be achieved and an assessment of the probability that the next scheduled requirement will be met on time.

Appendix C
Wasteload Management Report

Sanitary Sewage System
Annual
Wasteload Management Report
For The 2017 Operating Year

Prepared for:

The Borough of Turbotville
PO Box 264
Turbotville, PA 17772

March 5, 2018

Prepared by:

Bruce Foreman

Bruce Foreman

Table of Contents

Introduction	1
Wastewater Treatment Facilities.....	2
Treatment Summary	2
Treatment Requirements.....	2
Flow Pattern.....	2,3
Solids Handling.....	3
Infiltration/Inflow Remediation.....	4
Anticipated I/I Maintenance,Repair,Relocation/ Modifications.....	4
Industrial Waste Report.....	5
Sewer Use Ordinance.....	5
Sewer Extensions.....	6
Major Equipment.....	6
Monitoring.....	6
Routine Maintenance.....	6
Combined Sewer Regulators And Overflows.....	7
Condition of the System.....	7
Hydraulic Loading Information.....	7
Organic Loading Information.....	8
Hydraulic and Organic Loading Data Spreadsheet and Graphs	
Borough Official Acknowledgement and Approval	
Meter Calibration Certification	
Exhibits	

Introduction

This Municipal Wasteload Management Report gives an analysis of the organic and hydraulic loading of the Turbotville Wastewater Treatment System during the past five years and provides a projection for the coming five years. The provisions of the Municipal Wasteload Management Report are to manage discharges into a municipal sewage facility, such that the Borough is able to (1) effectively manage extensions and connections to the sewer system and (2) prevent the occurrence of an overloaded sewage facility. The report has been prepared to meet the requirements of Chapter 94, paragraph 25, of the regulations of the Pennsylvania Department of Environmental Protection.

The information presented herein has been developed from data furnished by the borough, its employees, and from on-site inspections.

For reference, the following should be noted:

Owner: The Borough of Turbotville

Address: P.O. Box 264
Turbotville, PA 17772

Operator: Bruce W. Foreman
Cert. #S7422

Telephone: (570)649-5476

NPDES Permit #: PA 00281000

Receiving Stream: Unnamed Tributary to Warrior Run

WASTEWATER TREATMENT FACILITIES

The Borough of Turbotville is a small rural community surrounded by Lewis Township, located at the northern tip of Northumberland County. The Borough owns and operates a wastewater treatment plant located in the northwest quadrant of Turbotville (Latitude 41° 06'08", Longitude 76° 46'32"). The description of the existing Turbotville Wastewater Treatment Plant is as follows:

1. Treatment Summary

The treatment plant employs a biological treatment process to attain treatment goals. The plant is designed for an average hydraulic capacity of 0.136 MGD and an organic capacity of BOD5 loading of 226.8 pounds per day. The raw sewage is comminuted, then pumped to the activated sludge process, settled, disinfected, and discharged into an unnamed tributary of Warrior Run (a tributary of the west branch of the Susquehanna River). The sludge from the secondary settling basin is pumped to an aerobic digester for stabilization. Final deposition of sludge is accomplished utilizing dewatering (via drying beds) and land filling.

2. Treatment Requirements

The Borough of Turbotville Wastewater Treatment Plant operates under the regulation and approval of the Pennsylvania Department of Environmental Protection (Pa DEP) and the United States Environmental Protection Agency (USEPA). USEPA regulatory requirements are presented through the National Pollutant Discharge Elimination System (NPDES) Permit No. PA0028100.

* Flow	0.136MGD
* C-BOD5	20.0 lb/day
* TSS	34.0 lb/day
* PH	6.0 - 9.0 S.U.
* Fecal Coliform	
- (5/1 - 9/30)	200 MPN/100ml
- (10/1 - 4/30)	2,000 MPN/100ml
* Ammonia (N)	
- (6/1 - 10/31)	5.5 lb/day
- (11/1 - 5/31)	17.0 lb/day
* Chlorine	.45 Avg. and 1.48 Max
* Lead	Reporting
* Copper	Reporting
* Total Phosphorus	Reporting
* Raw Influent	Report Avg. lbs BOD and TSS

3. Flow Pattern

The following paragraphs provide a brief description of the major process units employed at the plant.

The plant receives sewage from the Turbotville Borough and includes all residential, commercial, and industrial sewage generated within Borough limits. All wastewater generated in the Borough flows to a 0.250 MGD mazoration chamber where it passes through a 0-300 gpm mazorator.

The mazoration chamber is equipped with a 450, two-inch clearance manual bypass bar screen. The wastewater then flows by gravity to an on-site 0.250 MGD two-way adjustable flow splitter box. The splitter box is capable of delivering 0 to 100% flow to either secondary treatment unit trains or a combination thereof.

The preliminary effluent proceeds into two 50,000-gallon aeration tanks where biological treatment occurs. Sludge recirculated from the secondary settling basins is mixed with preliminary effluent and air is introduced via non-clogging coarse air diffusers to provide treatment. The biologically-activated effluent from the aeration tanks flow by gravity into two 16,700-gallon secondary settling basins where the biomass generated in the aeration tanks is settled out. The settled sludge is either returned back to the head of the aeration tanks or wasted from the process. The secondary settling basin effluent flows by gravity into two 2,100-gallon chlorine contact tanks and is disinfected. The chlorine contact effluent flows through the 980-gallon final effluent flow metering chamber and is discharged to an unnamed tributary of Warrior Run (a tributary of the west branch of the Susquehanna River).

4. Solids Handling

The sludge wasted from the activated sludge process is pumped via two 3" 0-105 gpm air lift pumps located in the secondary settling basin to a 29,700 gallon aerobic digestion tank. Stabilization and thickening occurs in the aerobic digestion tank. The thickened stabilized sludge is pumped to the sludge drying beds where it is dewatered, removed and hauled to an approved landfill. During the winter months the drying beds are not used, because of the freezing temperatures. We utilize contract haulers to haul liquid sludge to other wastewater treatment plants for further treatment and disposal.

INFILTRATION / INFLOW REMEDIATION

As a routine maintenance practice the Borough has continued to identify and eliminate I/I to the sewer system through regular inspection, smoke testing, video inspection, and repair to the system. The following is a list of what was done in the year 2017:

1. We capped off a six inch line no longer used.
2. We capped off a four inch lateral no longer in use.
3. We fixed two laterals that were leaking.
4. Chip Adams camera 2192 feet of sewer line in the boro.

ANTICIPATED I/I MAINTENANCE, REPAIR, RELOCATION/MODIFICATIONS

During 2018, the Borough plans to continue working on inflow/infiltration problem within the collection system, by performing investigations to locate problems and making appropriate corrective actions. The following will serve as the Borough's schedule of anticipated O&M, major repairs and upgrades listed below:

1. Structural remediation activities to be done in 2018:

- a. The Turbotville Borough is in the beginning stages of upgrading the wastewater treatment plant.
2. Collection and conveyance system
 - a. Will continue televising the main lines for I/I problem areas. As problems are found, they will be addressed accordingly.
3. Institutional remediation activities to be done in 2018:
 - a. Continue to review sewer use ordinances and amend as needed.
 - b. Continue to work with the residents to repair sanitary service laterals found to be defective through the following procedure:

The Borough will send a certified letter to the resident describing the problem, defining the amount of time to correct the problem (i.e., 60 days from receipt of certified letter) and enforcement actions to be taken if compliance is not achieved.

INDUSTRIAL WASTE REPORT

The Borough of Turbotville has sewer use ordinances in place to regulate the discharge of sanitary and industrial wastewater into its sewer system. In 1994, the Borough developed Water and Wastewater Design Standards. The ordinances and design standards were reviewed in 1995 and were promulgated in 1996. There are no "Major Contributing Industries" as defined by the National Pollutant Discharge Elimination System (NPDES). The Borough Authority has not entered into any formal agreements with or issued permits to any industrial discharges

SEWER USE ORDINANCE

Providing for the creation and operation of a municipal sewer system for the Borough of Turbotville, Northumberland County, prescribing the regulations for connections thereto and the use thereof; prohibiting surface drains and drainage of sewage and waste waters; prohibiting erection and construction and maintenance of cesspools, privies, septic tanks and similar facilities for disposal of waste and sewage and requiring abandonment and discontinuance of such facilities now in use; prescribing penalties for violation

SEWER EXTENSIONS

Turbotville Borough had no new connections in 2017. Two accounts were deleted but could be reconnected in the future.

MAJOR EQUIPMENT

Turbotville Borough owns two trucks and a skid steer. All other needed maintenance equipment can be rented or contracted as the need arises

MONITORING

Routine monitoring of operation is in compliance with requirements of the NPDES Permit. Flow is continuously recorded. BOD5, C-BOD5, Total suspended solids, Fecal coliform, Ammonia, Total Phosphorus, Total Lead and Total Copper are analyzed weekly by collecting an 8 hr. grab composite. Seewald Testing does the testing for us. Total chlorine and pH are measured daily by the operators.

ROUTINE MAINTENANCE

The operator performs routine maintenance of the wastewater treatment facilities on a regular scheduled basis. Major repairs are performed only as needed. Such work is done on a contract basis with local contractors or by the Borough's personnel.

Maintenance done in 2017:

1. LTS Plumbing brought jet truck and unclogged return line in tank#1 and replaced the cap.
2. We cleaned out the chlorine tank when needed.
3. We cleaned and replaced air diffusers on the aeration tank.
4. Joe's welding replaced one air valve in each aeration tank and also fixed air leaks.
5. Dan Byler Construction put a new roof over the drying beds.
6. Shively's Electric did yearly maintenance inspection on the electrical boxes.
7. Shively's Electric came and fixed electrical problems in July.
8. Routine maintenance was done to the blowers.

COMBINED SEWER REGULATORS AND OVERFLOWS

The sewer system does not contain any combined sewers or overflows.

CONDITION OF THE SYSTEM

The system is in fair condition. We are currently in the process of selling the sewer plant to American Water. So the upgrade planned is on hold until decisions are made.

HYDRAULIC LOADING PROJECTIONS

The 5-year average flows is followed by the following information:

**PADEP Chapter 94 Spread:
Sewage Treatment P1**

Reporting Year:

Facility Name:

Permit No.:

Persons/EDU:

Existing Hydraulic Design Capacity: MGD
 Upgrade Planned in Next 5 Years?
 Future Hydraulic Design Capacity: MGD

Existing Organic Design Capacity: lbs BOD5/day
 Upgrade Planned in Next 5 Years?
 Future Organic Design Capacity: lbs BOD5/day

Monthly Average Flows for Past Five Years (MGD)

Month	2013	2014	2015	2016	2017
January	0.055	0.043	0.033	0.055	0.103
February	0.047	0.035	0.03	0.081	0.048
March	0.045	0.055	0.064	0.041	0.09
April	0.052	0.067	0.079	0.033	0.067
May	0.039	0.056	0.031	0.033	0.07
June	0.03	0.029	0.053	0.029	0.03
July	0.036	0.032	0.08	0.0298	0.048
August	0.025	0.04	0.042	0.036	0.059
September	0.025	0.026	0.039	0.031	0.036
October	0.028	0.032	0.047	0.036	0.046
November	0.033	0.027	0.043	0.034	0.034
December	0.061	0.059	0.077	0.045	0.037

Monthly Average BOD5 Loads for Past Five Years (lbs/day)

Month	2013	2014	2015	2016	2017
January	47	65	39	96	77
February	57	48	47	238	81
March	62	80	80	95	64
April	46	56	78	62	87
May	37	99	56	75	73
June	37	38	67	79	72
July	35	69	57	72	86
August	48	64	53	77	118
September	67	48	76	72	69
October	36	54	85	48	76
November	35	41	110	59	73
December	39	70	116	69	98

Annual Avg 0.04
 Max 3-Mo Avg 0.049
 Max : Avg Ratio 1.23
 Existing EDUs 365.0
 Flow/EDU (GPD) 109.6
 Flow/Capita (GPD) 31.3
 Exist. Overload? NO

Annual Avg 46
 Max Mo Avg 67
 Max : Avg Ratio 1.47
 Existing EDUs 365
 Load/EDU 0.125
 Load/Capita 0.036
 Exist. Overload? NO

Projected Flows for Next Five Years (MGD)

	2018	2019	2020	2021	2022
New EDUs	6.0	2.0	2.0	2.0	2.0
New EDU Flow	0.0008	0.0003	0.0003	0.0003	0.0003
Proj. Annual Avg	0.0469	0.0472	0.0475	0.0478	0.0481
Proj. Max 3-Mo Avg	0.0651	0.0655	0.0659	0.0663	0.0667
Proj. Overload?	NO	NO	NO	NO	NO

Projected BOD5 Loads for Next Five Years (lbs/day)

	2018	2019	2020	2021	2022
New EDUs	6	2	2	2	2
New EDU Load	1.141	0.380	0.380	0.380	0.380
Proj. Annual Avg	70	71	71	72	72
Proj. Max-Avg	125	126	127	127	128
Proj. Overload?	NO	NO	NO	NO	NO

Show Precipitation Data on Hydraulic Graph?

Total Monthly Precipitation for Past Five Years (Inches)

Month	2013	2014	2015	2016	2017
January	1.4	1.9	0.4	6.4	6.4
February	1.2	1.3	0.5	7.6	6.9
March	1.5	2.8	1.6	1.7	6.8
April	3.8	4.7	4.1	3.3	4.8
May	3.7	4.6	1.8	2.1	6.4
June	4.1	3.5	8.4	3.1	1.8
July	6.7	5.3	6.6	3.3	10.7
August	2.4	5.3	3.7	3.5	5.4
September	1.7	1.7	4.2	3.3	2.0
October	3.4	3.9	4.0	2.4	5.6
November	3.7	2.2	2.8	2.3	2.1
December	2.1	4.4	4.9	1.5	4.7

5-Year Measured and Projected Hydraulic Loads Turbotville Wastewater Plant, PA0028100

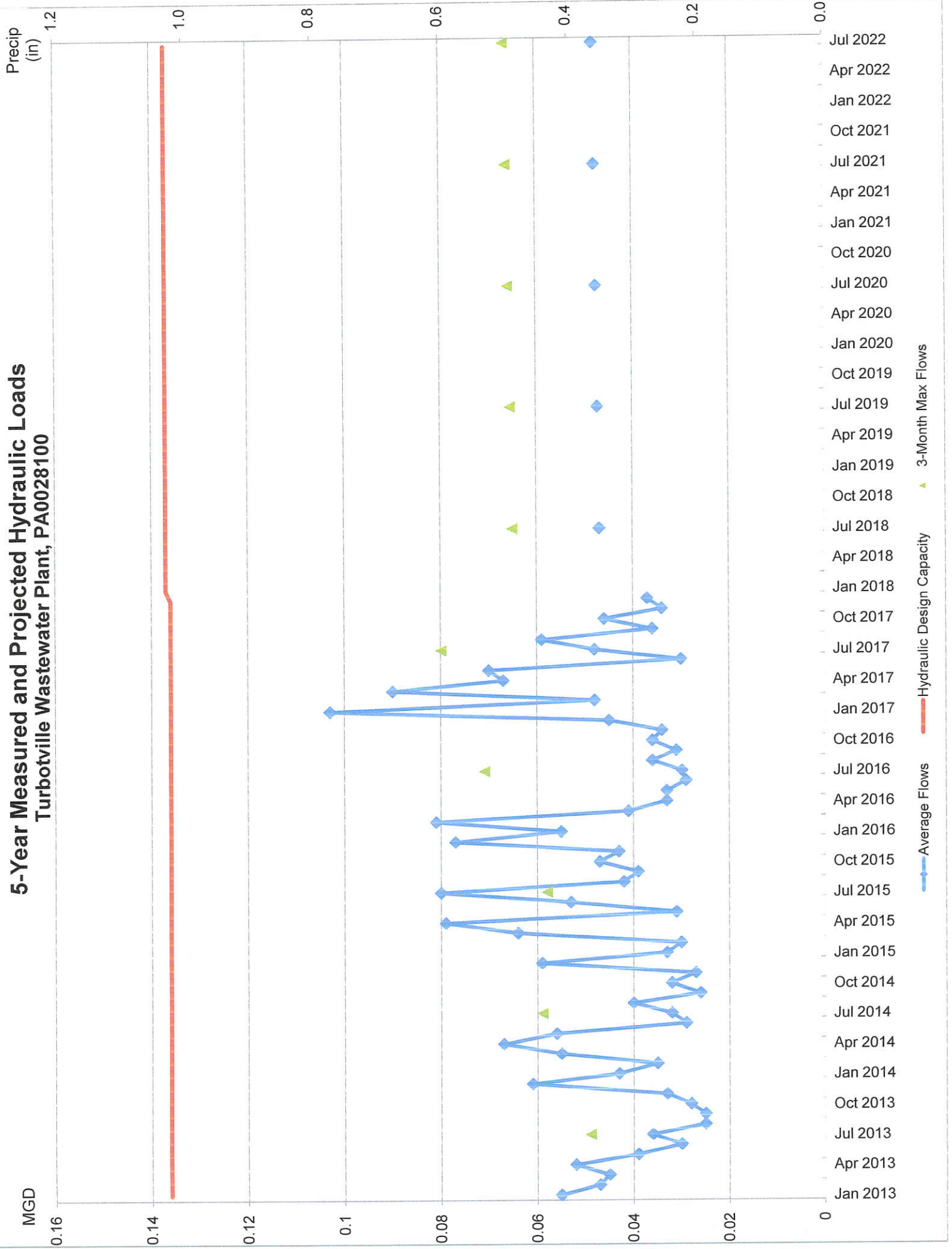

There is a subdivision which has one connection so far. The aforementioned subdivisions will add 12 new EDUs to the Turbotville Sanitary Sewer System. No additional housing units were built in 2017. Six EDU's are planned for the first year in the projection year for new homes being built. There was two accounts deleted in 2017.

The five year projections are based on two connections per year for the next five years and Active EDU's 362.5

2010 Census Population	705
2010 Census Households	306
Population per EDU	2.48
Gallons per Capita	68
Gallons per EDU	143
Connections 2017	0
2018-2022	2

ORGANIC LOADING PROJECTIONS

Projections are based on 6 connections the first year and two connections the next four years. The projected organic loadings were based on the 5-year average BOD loadings and by the following information:

2010 Estimated Population	705
2010 Households	306
EDU's	365.5
LB/DAY BOD's per EDU	0.2
Connections 2018-2022	2

Hydraulic and organic loading for the past 5 years and projection loadings are shown on the spreadsheet on the following page with graphs.

BOROUGH OFFICIALS ACKNOWLEDGEMENT

5-Year Measured and Projected Organic Loads Turbotville Wastewater Plant, PA0028100

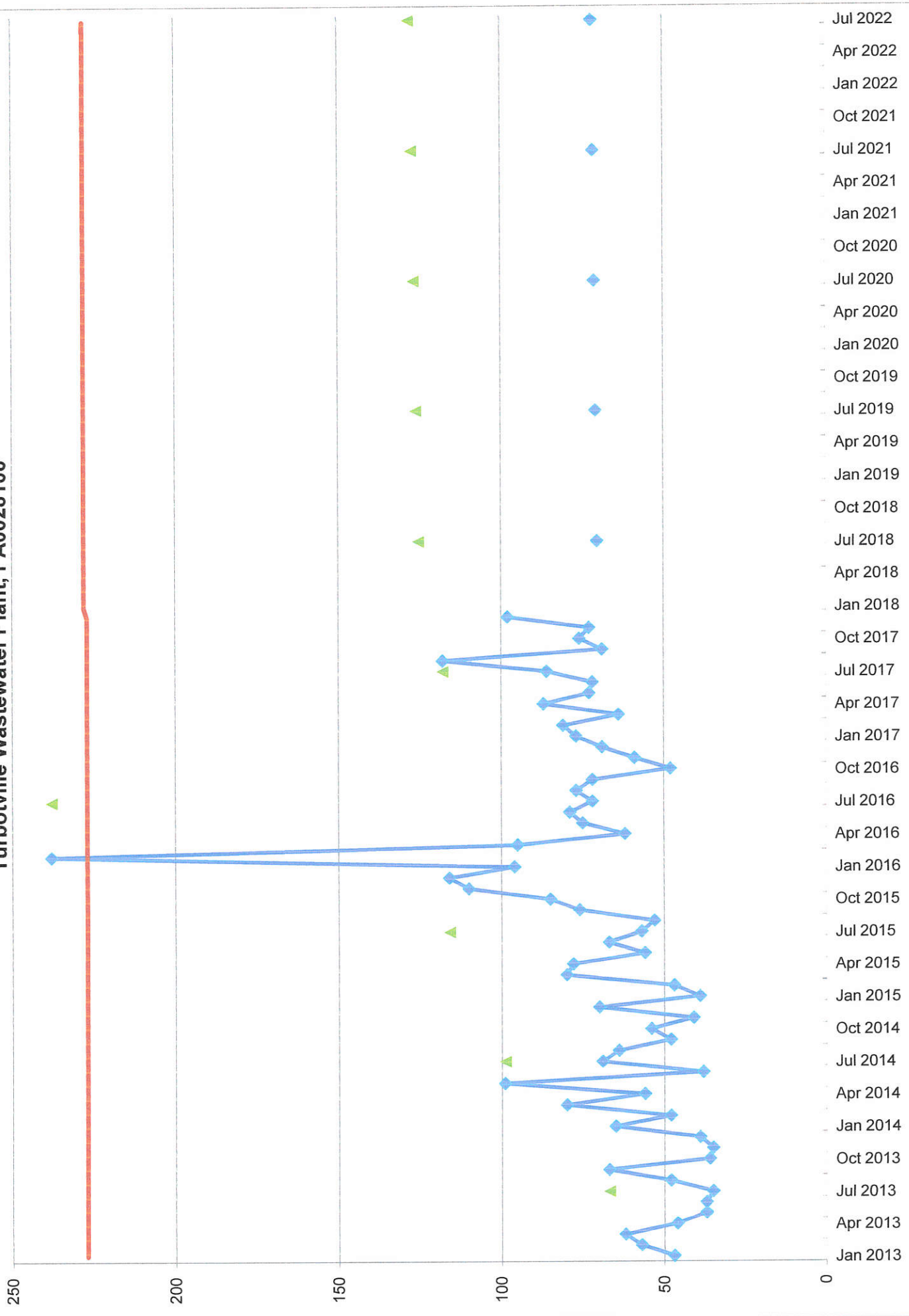

AND APPROVAL

The Borough of Turbotville is committed to provide adequate sewage treatment services to the community. The objectives of this report are to manage, identify, and address system needs now and in the future. This report has been reviewed and is hereby approved for submission to the Pennsylvania Department of Environmental Protection by

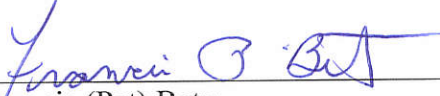

Francis (Pat) Betz

Borough Council President



Nathan Yoder

Borough Council Vice President

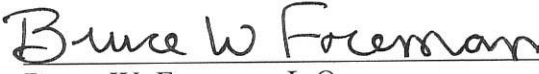

Bruce W. Foreman, L.O.
Certified Operator

EXHIBITS

1. Copy of manhole inventory/inspection list (attached)
2. Copy of Wellington Estates Lot Plan
3. Copy of the flow meter calibration

Manhole No.	Location	Pre-cast or Brick	Comments
-------------	----------	-------------------	----------

Manhole No.	Location	Pre-cast or Brick	Comments
1	At plant by comminutor	Pre-Cast	4' 6" deep
2	Lot by Lola Pursel	Pre-Cast	5' 6" deep
3	Behind Sewer operations bldg.	Pre-Cast	4' 10" deep
4	Behind Lola Pursel's	Brick	4' 5" deep (sealed w/mL72 and flex-seal 2003)
5	Coopers lot below Carl Heiss	Brick	119" deep
6	On lot of 78 King St.	Brick	141" deep
7	Second St.	Pre-Cast	146" deep
8	Second St. by Reedy's	Pre-Cast	92" deep
9	King St.	Pre-Cast	10' 6" deep
10	King St.	Brick	11' 2" deep
11	King St. @Paradise	Brick	10' deep
12	King St.	Brick	9' 8" deep
13	King St.	Brick	9' 2" deep
14	King St.	Brick	8' 6" deep
15	Wash. St. +Locast Alley	Pre-Cast	10' 6" deep 8" inlet
16	Behind Atttel	Pre-Cast	7' 11" deep
17	Jim Chamberlin	Pre-Cast	51" deep
18	Behind Zenith Rovenolts	Pre-Cast	7' 6" deep
19	Locust Alley by Terry's Garage	Pre-Cast	7' 3" deep
20	Main St. + Washington St.	Pre-Cast	13' 5" deep
21	Washington St. + Virgin	Pre-Cast	7' 5" deep Elevated bypass to #110
22	Virgin Alley Behind Dale Mastelers	Pre-Cast	5' 7" deep installed 2000
23	Behind Roy Russel	Pre-Cast	111.5" deep installed 2000
24	Paradise St.	Pre-Cast	9' deep installed 2001
25	Paradise St.	Pre-Cast	9' deep
26	Behind Cooper's Hardware	Pre-Cast	4' deep installed 2000
27	Sheer Image	Pre-Cast	3' deep
28	Broadway + Washington St.	Pre-Cast	6' 8" deep
29	Broadway	Pre-Cast	7' 3" deep installed 1998
30	Broadway	Pre-Cast	6' 7.5" deep installed 1998
31	Broadway	Pre-Cast	8' 9.5" deep installed 1998
32	Broadway	Pre-Cast	8' 5" deep installed 1998
33	Park by Fountain	Pre-Cast	21' 6" deep Brick chimney
34	Ballfield	Pre-Cast	17' 3" Brick riser
35	Cornor of Tennis Court	Pre-Cast	9' deep
35-1	Wellington Estates	Pre-Cast	10' Deep
35-2	Wellington Estates	Pre-Cast	6' Deep
36	Pine St. by Tennis Court	Pre-Cast	6' 11" deep
37	Pine + Church St.	Pre-Cast	5' 7" deep Sealed 2002
38	Pine St. by Applemans	Pre-Cast	5' deep brick chimney
39	Stamms lot by Shell's	Brick	11 ft. deep Wet
40	Virgin Alley by Shell's	Pre-Cast	5' Deep installed 2000
41	Virgin Alley by Mensch	Pre-Cast	5' 8" deep installed 2000
42	Virgin Alley by Hotel	Pre-Cast	5' 4" Deep
43	Stamms lot by Shell's	Pre-Cast	7' 6" deep Wet
43-1	Wellington Estates	Pre-Cast	5' Deep
43-2	Wellington Estates	Pre-Cast	6' Deep
44	Stamm's lot by Shell's	Pre-Cast	11 ft. deep 2002

Manhole No.	Location	Pre-cast or Brick	Comments
45	Route 44 by Shell's	Brick	4' deep (sealed w/mL72 2002)
46	Locust Alley by Shellenberger	Pre-Cast	3' deep installed 2000
47	Locust Alley by Starr	Pre-Cast	5' deep installed 2000
48	Locust Alley by Church Lot	Pre-Cast	4' 10" deep
49	Alley Behind Allison	Pre-Cast	12' 4" deep Drop inlet from #50 installed 2000
50	Paradise St.at Zion Church	Brick	5' 6" deep (sealed w/ mL72 and flex-seal 2003)
51	Paradise St. @ Bower Apts.	Pre-Cast	5' 8" deep
52	Alley behind Allison's	Pre-Cast	10' deep installed 2000
53	Alley behind Cinthia Shaffer	Pre-Cast	11' 6" deep Elevated inlet from #55
54	Behind Denny Engle	Pre-Cast	2' deep
55	Paradise St.	Brick	7 1/2 ft deep (sealed w/ mL72 2002)
56	Pine St. & Paradise St.	Pre-Cast	3' deep
57	Pine St. by Kline's	Pre-Cast	6' 6" deep
58	Pine St. by Appleman's	Pre-Cast	4' 10" Deep brick riser
59	Washington St by Bill Brooks	Pre-Cast	6' 8" deep
60	Washington St. & Colonial Lane	Pre-Cast	5' 9" deep
61	Colonial Lane & Wash. Place	Pre-Cast	13' 2" deep
62	West Wash. Place	Pre-Cast	11' 6" deep
63	West Wash. Place	Pre-Cast	11' 11" deep
64	East Wash. Place	Pre-Cast	11' 8" deep
65	East Wash. Place	Pre-Cast	4' 8" deep
101	First Street	Pre-Cast	6 ft. deep 2001
102	First Street and Locust Alley	Brick	4 feet deep (sealed w/mL72 and flex-seal 2003)
10	Locust Alley behind Gary Enterline	Pre-Cast	5' 2" deep installed 2000
104	Locust Alley by Bob Crawford	Pre-Cast	7' 2" deep installed 2000
105	Washington St. & Locust Alley	Pre-Cast	7' 10" deep
106	First St. by Donna Keefer	Pre-Cast	47" deep
107	By Grooms in Virgin Alley	Brick	5' 6" deep
108	Virgin Alley behind Bob Aderhold	Brick	6' 5" deep
109	Virgin Alley behind Clyde Williams	Brick	9' 2" deep
110	Virgin Alley behind Marve Smith	Brick	8' 6" deep
201	Our property by stone pile	Pre-Cast	58" deep
202	Clark's lot	Pre-Cast	4 ft. deep (WET)
203	Clark's lot by Railroad	Pre-Cast	6 1/2 ft. deep
204	See notes on attached map	Pre-Cast	6' 10" deep
205	Rte. 44 by Clarks	Pre-Cast	81 1/2" deep
206	Rte. 44 by V.F.W.	Pre-Cast	5' 4" deep
207	At intersection of Rts. 54 & 44	Pre-Cast	5' 6" deep
208	Front of Bank	Brick	4' deep (sealed w/mL72 and flex-seal 2003)
209	FoodRite	Pre-Cast	5' deep



LRM, Inc

Instrumentation & Disinfection Systems

Calibration Date
1/18/2017

User

Turbotville WWTP
P.O. Box 264
Turbotville PA 17772

Job Site

Turbotville WWTP
2 Adam Street
Turbotville PA 17772

Attn

Instrument Model No.

Instrument S/N

Endress & Hauser FMU90

EA0097150E6

Instrument Loop

Input Type

Plant Effluent

Ultrasonic

Primary Signal Producer

Calibrated Range

45 deg Triangular Weir

0-800 GPM

Instrument Settings

Found

Changed To

Zero	Span
3.64 ft	2.40

Zero	Span
N/A	N/A

Calibration Data

Input %	Input Value	Output Value	% Error After Calibration
0 %	0.00 GPM	4.000 mADC	0.00%
50 %	400.00 GPM	12.000 mADC	0.00%
100 %	800.00 GPM	20.000 mADC	0.00%

Equipment Used Isco Standards Book Stick Rule

Adjustments / Actions Taken: New Flow Curve

Comments:

Service Representative

Date 1/25/2017

Michael Sollazzo

215 N. Main Street - Souderton, Pa 18964 - 215-721-4840 - Fax 215-721-4923

Appendix D
Phosphorous Removal Pilot Study Documentation



November 27, 2018
Project No. 0047-058-000

Mr. Thomas Randis
PA Department of Environmental Protection
208 West Third Street
Suite 101
Williamsport, PA 17701

RE: Phosphorus Removal Pilot Study Final Report
NPDES Permit No. PA0028100
The Borough of Turbotville
Northumberland County

Dear Mr. Randis:

Please find the final report to the Turbotville's Wastewater Treatment Plant Phosphorus Removal Pilot Study attached to this letter. Should you have any questions or comments, please feel free to contact me via email: gas@uni-tec.com or phone: 814-238-8223 x341.

Sincerely,
UNI-TEC CONSULTING ENGINEERS, INC.

A handwritten signature in black ink that reads "Garrett A. Stoy". The signature is written in a cursive, flowing style.

Garrett A. Stoy, EIT
Project Manager

Enclosure

GAS/gas

Email cc: Turbotville Borough, (w/encl.)
Derek Garner, PADEP, (w/encl.)
Daniel Thetford, PADEP, (w/encl.)
Edward Hulstein, PE, PAWC, (w/encl.)

**Final Report
Phosphorus Removal Pilot Test**

Turbotville Borough Wastewater Treatment Plant

NPDES Permit No. PA0028100

**The Borough of Turbotville
Northumberland County, PA**

November 27, 2018

Prepared For:

**The Borough of Turbotville
PO Box 264, 2 Adams Street,
Turbotville, PA 17772-0264**

Prepared By:

**Uni-Tec Consulting Engineers, Inc.
2007 Cato Avenue
State College, PA 16801-2765
(814) 238-8223**

UTCE File No.: 0047-058-000



Table of Contents

I.	Introduction.....	1
II.	Existing Treatment Process	2
III.	Pilot Study Modifications.....	4
IV.	Pilot Study Results	4
V.	Conclusion	5
VI.	Schedule of Permanent Installation	5
VII.	Appendices	6
	A. Pilot Study Memo.....	7
	B. Pilot Study Drawing Sheets	16
	C. Dosage Rate Data	19
	D. Dosage Rate Graph	21

Borough of Turbotville Wastewater Treatment Plant Phosphorus Removal Pilot Study

I. Introduction

The Borough of Turbotville was faced with more stringent effluent limitations with the renewal of their NPDES Permit in 2015 that took effect June 1, 2018. The main concern was that the plant could not meet the limitations of Phosphorus levels in the wastewater treatment plant's effluent. It was decided that a pilot study to determine if the addition of liquid alum could decrease the effluent concentration of Phosphorus. The following report explains the findings of the study.

II. Existing Treatment Process

All sewage flows by gravity to the existing wastewater treatment plant (WWTP) located at the northwest corner of the Borough. The WWTP (NPDES Permit No. PA0028100) is permitted for a design flow rate of 0.136 MGD, and the design influent mass organic loading rate of 227 lbs/day BOD5. Treated effluent is discharged to the Unnamed Tributary to Warrior Run, within the West Branch Susquehanna River drainage basin. The WWTP's past and current effluent discharge requirements are shown in **Tables 1** and **2** on the following page. The most recent NPDES permit issued for the WWTP provides two separate Effluent Limitations: Permit issuance through May 31, 2018 (Table 1) and June 1, 2018 through August 31, 2020 (Table 2). Additionally, with the issuance of the renewed NPDES Permit in 2015, the Borough is subject to more stringent effluent limitations (see **Table 2**), and the existing WWTP is not capable of achieving the Total Phosphorus limitation.

**Table 1: NPDES Effluent Limitations
September 1, 2015 through May 31, 2018**

Parameter	Average Monthly (lbs/day)	Weekly Average (lbs/day)	Average Monthly (mg/L)	Weekly Average (mg/L)	Instant. Maximum (mg/L)
pH	--	--	--	--	6.0 min/9.0 max
Total Residual Chlorine	--	--	0.45	--	1.48
CBOD ₅	13	20	12	18	24
Total Suspended Solids	34	34	30	30	30
Fecal Coliform (CFU/100 mL) May 1 – Sep 30	--	--	200 Geo Mean	--	1,000
Fecal Coliform (CFU/100 mL) Oct 1 – Apr 30	--	--	2,000 Geo Mean	--	10,000
Ammonia-Nitrogen May 1 – Oct 31	7.0	10	6.0	9.0	12
Ammonia-Nitrogen Nov 1 – Apr 30	20	31	18	27	36
Total Phosphorus	Report	Report	Report	Report	--
Total Copper	Report	Report	Report	Report	--
Total Lead	Report	Report	Report	Report	--

**Table 2: NPDES Effluent Limitations
June 1, 2018 through August 31, 2020**

Parameter	Average Monthly (lbs/day)	Weekly Average (lbs/day)	Average Monthly (mg/L)	Weekly Average (mg/L)	Instant. Maximum (mg/L)
pH	--	--	--	--	6.0 min/9.0 max
Total Residual Chlorine	--	--	0.45	--	1.48
CBOD ₅	13	20	12	18	24
Total Suspended Solids	34	34	30	30	30
Fecal Coliform (CFU/100 mL) May 1 – Sep 30	--	--	200 Geo Mean	--	1,000
Fecal Coliform (CFU/100 mL) Oct 1 – Apr 30	--	--	2,000 Geo Mean	--	10,000
Ammonia-Nitrogen May 1 – Oct 31	4.0	5.5	3.5	5.0	7.0
Ammonia-Nitrogen Nov 1 – Apr 30	11.5	17	10.5	15	21
Total Phosphorus	2.96	2.96	2.60	2.60	2.60
Total Copper (µg/L)	0.04	0.08 Daily Max	36.31	72.62 Daily Max	90.77
Total Lead	Report	Report	Report	Report	--

III. Pilot Study Modifications

The pilot study was proposed to lower the levels of Phosphorus in the WWTP's effluent. Turbotville's WWTP has an average influent concentration of soluble phosphorus of 8 MG/L, and the new effluent limitation is 2.6 mg/L of total phosphorus. The hydraulic design of the treatment facility is 0.136 MGD, and the recent annual average monthly flow rate is 0.06 MGD. The Pilot Study Memo to the DEP can be found in **Appendix A**.

Phosphorus is removed primarily by the continuous addition of liquid alum to the splitter box, as seen in the attached drawings, **Appendix B**. The injection piping was buried 4 feet below grade from the garage with the chemical storage to the primary injection point. The piping was heat wrapped when above grade and when it was buried less than 4 feet below grade. The initial idea was to install a secondary application points at the Extended Aeration Tanks (Activated Sludge) once a minimal dosage rate was studied to prove effective at eliminating the Phosphorus concentration in the WWTP's effluent at the primary application point. However, the optimal dosage rate to minimize chemical usage while meeting the Phosphorus effluent limitation was never determined due to irregular high system flows resulting from the excessive amount of precipitation this year.

The initial calculations indicated that the dosage rate for alum per the WWTP's influent characteristics is 0.78 gallons per hour. The rate was used to select a chemical feed pump with dosing rates between 0 and 2.5 gph. The pump has a turndown ratio for specific manual field adjustments. The chemical feed pump is located near the chemical storage in the garage next to the Operations Building.

IV. Pilot Study Results

The results of the Pilot Study including the dosage rate per day and effluent test results can be found in **Appendix C** of the report. Based on the dosage rate mentioned above 0.78 gph, the staff at the Turbotville WWTP started the study with the equivalent rate of 49 mL/min. After comfortable test results were received, the staff was directed to lower the rate as seen in the table in **Appendix C**. The same table also shows the proposed dosage rate, measured dosage rate, and average for each day. A graph comparing the average weekly dosage rate to the Phosphorus concentration is included in **Appendix D**. At the conclusion of the study, it was found that 20 mg/L of liquid alum would effectively remove the Phosphorus concentration below the NPDES limit.

The data gathered from the study does not support a defined dosage rate that optimizes chemical usage while eliminating sufficient amounts of Phosphorus to meet the NPDES effluent limitations. What the data does tell us, during the study, is that we are dosing enough liquid alum in the WWTP influent to remove enough Phosphorus to meet the limit. As seen in the graph and chart, the results of the study do not reflect a confident linear relationship with the data we have. This is mostly due to the influent fluctuations to the plant, resulting from the increased amount of

precipitation during the study. The study is pending a request to the DEP for an extension to the study.

V. Conclusion

Before the study began, the Phosphorus concentration in the WWTP's effluent exceeded the new NPDES limits effective June 1, 2018. The week of the more stringent limits, liquid alum was injected into the WWTP's influent at the head of the plant. After the week 1 test results arrived, the Borough of Turbotville saw effluent Phosphorus concentrations that indicated the liquid alum removed most of the Phosphorus. The Turbotville Wastewater Treatment plant has met the new NPDES permit Phosphorus effluent limits during the study. However, the study itself is difficult to draw a confident optimal dosage rate due to the inconsistencies of the data mentioned above. Therefore, an extension to the study to gather further data in order to confirm a dosage rate that will optimize chemical usage while meeting the NPDES Phosphorus effluent requirements has been requested to the DEP. The verdict of the request has not been decided at the time of this writing.

VI. Schedule of Permanent Installation

Please find the projected schedule outlined below once a verdict has been reached on the pilot study extension:

- Approximately 90 days to apply for the Water Quality Management Permit Part 2 permit and design the permanent Phosphorus removal system for Turbotville's Wastewater Treatment Plant.
- Approximately 60 days to install the permitted Phosphorus removal system.

The existing pilot study feed system shall be maintained during the design/permitting/construction of permanent installation. We shall continue to collect data in order to optimize the dosage rate.

Appendices

Appendix A – Pilot Study Memo

May 31, 2018

Francis Betz
Turbotville Borough
PO Box 264
2 Adam Street
Turbotville, PA 17772-0264

Re: Phosphorus Removal Pilot Testing
Turbotville Borough Wastewater Treatment Plant
NPDES Permit No. PA0028100
Turbotville Borough, Northumberland County

Dear Mr. Betz:

The Department of Environmental Protection (DEP) is in receipt of the May 25, 2018 request from Uni-Tec Consulting Engineers, Inc. (UTCE) to conduct pilot testing of a phosphorus removal/precipitation system. The phosphorus removal system is inconsistent with the Act 537 Sewage Plan for the Borough and therefore is authorized on an interim basis only, pending receipt and approval of either revised sewage planning or necessary permitting to fulfill the sewage plan in its present scope. The pilot test is granted effective June 1, 2018, under the following conditions:

1. This conditional authorization does not release the permittee from requirements held under the NPDES permit, Clean Streams Law or other applicable regulation regarding effluent quality.
2. All effluent limits shall remain in effect during the pilot study.
3. The facility's operator-of-record shall be responsible for any determinations to end the pilot study and revert to the existing, pre-pilot infrastructure should adverse conditions be observed.
4. All infrastructure changes, additions or deletions shall be performed under the supervision of licensed Professional Engineer Dennis Lingenfelter, PE025694E.
5. The permittee shall produce a summary memorandum or report every sixty (60) days identifying the following:
 - a. Summary of weekly alum used per injection point
 - b. Summary of resultant phosphorus concentration
 - c. Anticipated effectiveness of the pilot study if implemented on a permanent basis
6. The temporary installation, if converted to a permanent installation, may require WQM permitting.

7. This pilot study authorization shall conclude on or before October 31, 2018 without further written authorization from the Clean Water Program.
 - a. Any request for extension shall incorporate supplementary information regarding the required planning modification and / or implementation.
8. A final report / memorandum on the pilot effectiveness shall be provided to the Department within 180 days of this authorization.
 - a. If appropriate, the final report / memorandum shall include a schedule of necessary permanent installation construction and permitting.

Should the Borough of Turbotville transfer ownership and / or operational responsibility to a third party, the third party shall provide appropriate contact information for the operator and licensed engineer of record. The Borough of Turbotville shall submit an interim report regarding precipitate effectiveness prior to transfer. The third party receiving responsibility shall conclude the pilot effort and provide a summary report.

Please note that you are responsible for securing all other required permits, approvals and/or registrations associated with the project, if applicable, under Chapters 102 (erosion and sedimentation control), 105 (stream obstructions and encroachments) and 106 (floodplains) of DEP's regulations. Construction may not proceed until all other required permits have been obtained.

This letter does not waive, either expressly or by implication, the power or authority of the Commonwealth of Pennsylvania to prosecute for any and all violations of law arising prior to or after the issuance of this approval or the conditions upon which the approval is based. This letter shall not be construed so as to waive or impair any rights of the Department of Environmental Protection.

If you have any questions concerning this letter, please contact me at 570-321-6560 or jnorthridg@pa.gov.

Sincerely,



Jere Northridge, P.E.
Permits Chief
Clean Water Program

cc: NCRO-CW-Operations
Derek Garner, PADEP
Dennis Lingenfelter, UTCE
Garrett Stoy, UTCE
Scott Armbrust, PAWC

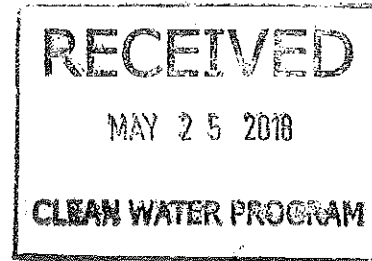

May 25, 2018
Project No. 0047-058-000

Mr. Jere Northridge, P.E. (via email)
PA DEP Clean Water
208 West 3rd St., Suite 101
Williamsport, PA 17701

RE: Pilot Study Memo
Phosphorus Removal
Borough of Turbotville
Northumberland County

Dear Mr. Northridge:

This memo has been prepared for the Borough of Turbotville Waste Water Treatment Plant's (WTP) pilot study. The pilot study is to lower the levels of Phosphorus in the WWTP's effluent. Turbotville's WWTP has an average influent concentration of soluble phosphorus of 8 MG/L, and the associated pending effluent limitation is 2.0 MG/L. The hydraulic design of the treatment facility is 0.136 MGD, and the recent annual average monthly flow rate is 0.06 MGD.

The Phosphorus will be removed primarily by the continuous addition of liquid alum to the Extended Aeration (Activated Sludge) basins in between the pump station and the splitter box, as seen in the attached drawings. The injection piping will run from the garage with the chemical storage to both the primary and secondary injection points. The piping shall be manifolded together with shut-off valves on the primary and secondary piping. Ball valves on the secondary piping will help throttle the flow to an equal rate in each aeration tank before the clarifiers.

Calculations (attached) indicate that the dosage rate for alum per the WWTP's influent characteristics is 0.78 gallons per hour. This rate is used to select a chemical feed pump with dosing rates between 0 and 2.5 gph. The pump will have a turndown ratio of 200:1 for specific manual field adjustments. A standby metering pump shall be provided in the case that the primary pump fails or needs maintenance. The chemical feed pump is located next to the operations building which houses the control panel for the pump station. An automatic start stop switch shall be wired to the metering pump and the booster pump's control panel. Once the booster pump station turns on and off, so will the metering pumps.

Mr. Jere Northridge, P.E. (via email)

2

May 25, 2018

PA DEP Clean Water

Project No. 0047-058-000

Should you have any questions or require additional information, please do not hesitate to contact me at (814) 238-8223 ext: 341 or email: gas@uni-tec.com.

Sincerely,
UNI-TEC CONSULTING ENGINEERS, INC.



Garrett A. Stoy, E.I.T.
Project Manager

Enclosure

Email cc: Robert Lynn, Turbotville (w/encl)
Diane Miller, Turbotville (w/encl)
Scott Armburst, PAWC (w/encl)
Keith Gabage, PAWC (w/encl)
Christopher Graf, PAWC (w/encl)

Turbotville Wastewater Treatment Plant

Phosphorus Removal (by Chemical Precipitation) Process Design

A. Operational Conditions

1. Average influent concentration of soluble phosphorus is anticipated to be 8 MG/L and the associated pending effluent limitation is 2.0 MG/L. Insignificant removal of soluble phosphorus by biological processes was assumed in performing the calculations set forth herein.
2. Hydraulic design of the treatment facility is 0.136 MGD and the recent annual average monthly flow rate is 0.06 MGD.
3. Phosphorus removal will be primarily by the continuous addition of liquid alum to the Extended Aeration (Activated Sludge) basins via the raw sewage pump station. If needed, provisions will be made to add liquid soda ash for pH adjustment.
4. Alum in the liquid form is approximately 48 percent aluminum sulfate and is represented by the following formula: $Al_2(SO_4)_3 \cdot 14 H_2O$. The aluminum ion (Al^{3+}) comprises approximately 9.1 percent of the compound by weight and the density of liquid alum is about 11.1 pounds per gallon.
5. Required weight ratio of aluminum ion (Al^{3+}) to soluble phosphorus (P) is assumed to be 3:1, because of the level of phosphorus removal required. This ratio will be adjusted based upon actual field performance values.

B. Estimated Chemical Usage (Based Upon Annual Average Monthly Flow Rate)

Estimated dosage of $Al_2(SO_4)_3 \cdot 14 H_2O$:

$$(3 \text{ MG/L } Al^{3+}/1 \text{ MG/L P}) \times (1/0.091) \times 6 \text{ MG/L} = 198 \text{ MG/L}$$

Estimated dosage of liquid alum:

$$198 \text{ MG/L} \times 1/0.48 = 413 \text{ MG/L}$$

Average daily usage of liquid alum:

$$413 \text{ MG/L} \times 0.06 \text{ MGD} \times 8.34 = 207 \text{ LBS/DAY}$$

$$207 \text{ LBS/DAY} \times 1 \text{ GAL}/11.1 \text{ LBS} = 18.7 \text{ GPD or } 0.78 \text{ GPH}$$

C. Estimated Theoretical Maximum Loss of Alkalinity

Theoretical required weight ratio of aluminum ion (Al^{3+}) to soluble phosphorus (P) is 0.87:1; the Al^{3+} dosage is herein assumed to be involved in reactions that reduce the alkalinity (HCO_3^-) of the wastewater by 5.5 MG/L (as $CaCO_3$) for each MG/L of Al^{3+} added.

Theoretical Al^{3+} dosage:

$$0.87 \text{ MG/L } Al^{3+}/1 \text{ MG/L P} \times 6 \text{ MG/L P} = 5.2 \text{ MG/L } Al^{3+}$$

Theoretical excess Al^{3+} dosage that could react to reduce alkalinity:

$$15.6 \text{ MG/L } Al^{3+} - 5.2 \text{ MG/L } Al^{3+} = 10.4 \text{ MG/L } Al^{3+}$$

Theoretical maximum loss of alkalinity:

$$10.4 \text{ MG/L } Al^{3+} \times 5.5 \text{ MG/L Alkalinity Loss (as } CaCO_3)/1 \text{ MG/L } Al^{3+} = 57.2 \text{ MG/L } CaCO_3$$

D. Estimated Chemical Sludge Quantity

Given:

Alum Dosage = 198 MG/L as $\text{Al}_2(\text{SO}_4)_3 \cdot 14 \text{H}_2\text{O}$

Theoretical Alum Dosage = 66 MG/L as $\text{Al}_2(\text{SO}_4)_3 \cdot 14 \text{H}_2\text{O}$

The following represents simplified reactions of alum with alkalinity and phosphate in water:

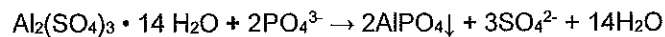

Using the above equations, it can be estimated that each MG/L of alum added precipitates 0.41 MG/L of AlPO_4 ; each MG/L of alum added above that necessary to precipitate the phosphorus present results in the generation of 0.26 MG/L of $\text{Al}(\text{OH})_3$.

Estimated Quantity of AlPO_4 :

$$66 \text{ MG/L Alum} \times 0.41 \text{ MG/L AlPO}_4 / 1 \text{ MG/L Alum} = 27.1 \text{ MG/L AlPO}_4$$

$$27.1 \text{ MG/L AlPO}_4 \times 0.06 \text{ MGD} \times 8.34 = 13.6 \text{ LB/DAY AlPO}_4$$

Estimated Quantity of $\text{Al}(\text{OH})_3$:

$$198 \text{ MG/L Alum} - 66 \text{ MG/L Alum} = 132 \text{ MG/L Alum (Excess)}$$

$$132 \text{ MG/L Alum} \times 0.26 \text{ MG/L Al}(\text{OH})_3 / 1 \text{ MG/L Alum} = 34.3 \text{ MG/L Al}(\text{OH})_3$$

$$34.3 \text{ MG/L Al}(\text{OH})_3 \times 0.06 \text{ MGD} \times 8.34 = 17.2 \text{ LBS/DAY Al}(\text{OH})_3$$

Total Estimated Chemical Sludge Quantity:

$$13.6 \text{ LB/DAY AlPO}_4 + 17.2 \text{ LBS/DAY Al}(\text{OH})_3 = 30.8 \text{ LB/DAY}$$

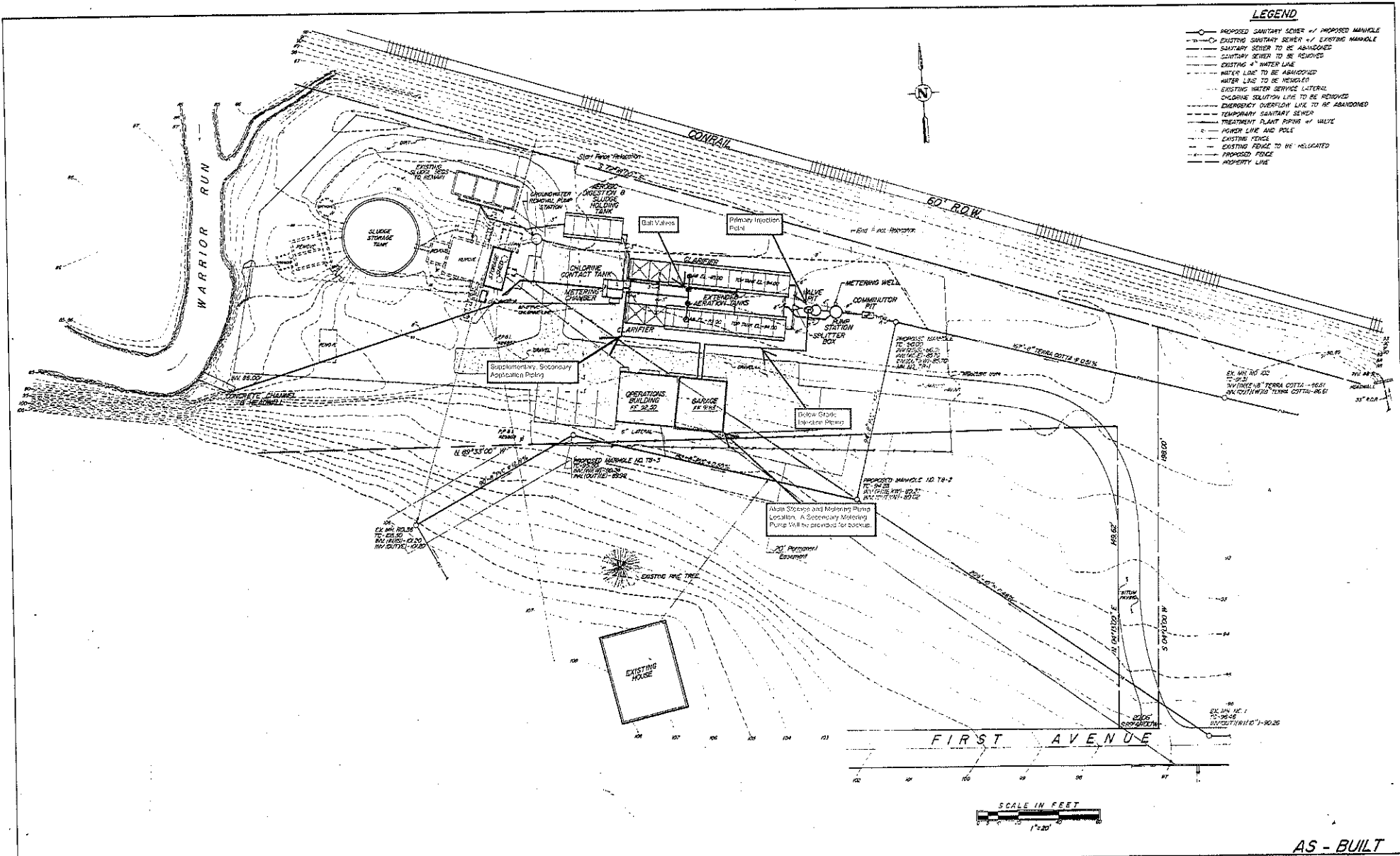

- LEGEND**
- PROPOSED SANITARY SEWER + / PROPOSED MANHOLE
 - EXISTING SANITARY SEWER + / EXISTING MANHOLE
 - SANITARY SEWER TO BE ABANDONED
 - SANITARY SEWER TO BE REMOVED
 - EXISTING WATER LINE
 - EXISTING WATER SERVICE LATERAL
 - WATER LINE TO BE ABANDONED
 - WATER LINE TO BE REMOVED
 - EXISTING WATER SERVICE LATERAL
 - CHLORINE SOLUTION LINE TO BE REMOVED
 - EMERGENCY OVERFLOW LINE TO BE ABANDONED
 - TEMPORARY SANITARY SEWER
 - TREATMENT PLANT PUMP + VALVE
 - POWER LINE AND POLE
 - EXISTING FENCE
 - EXISTING FENCE TO BE RELOCATED
 - PROPOSED FENCE
 - PROPERTY LINE

REV.	DATE	DESCRIPTION	BY	DISC. NO.
2	8-12-88	REV OPERATIONS BLDG	CLW	
1	7-22-88	ADDED METERS CHAMBER	CLW	

DESIGNED BY	CLW/CLW	DATE	2-88
CHECKED BY	CLW	DATE	2-88
DRAWN BY	CLW	DATE	2-88
CHECKED BY	CLW	DATE	2-88
SURVEYED BY	TJK	DATE	11-27-87
BOOK NO.	151	PAGE	1-17
BY	SP		

UNI-TEC, INC.
 CONSULTING ENGINEERS
 2041 CATO AVENUE
 SUITE 201
 STATE COLLEGE, PENNSYLVANIA 16801

SEWAGE TREATMENT PLANT EXPANSION
 TURBOTVILLE BOROUGH
 NORTHUMBERLAND COUNTY, PENNSYLVANIA
 CONTRACT 88-1

GENERAL PLAN

SCALE	1" = 20'
DRAWING NO.	E87170-1B.3
SHEET NO.	4 of 4

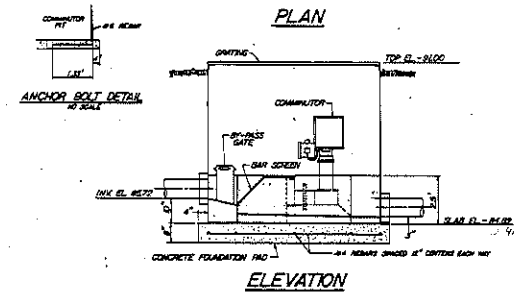
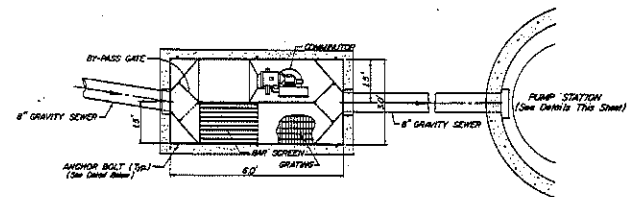
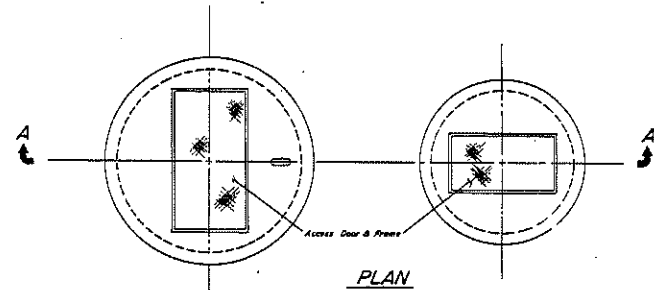
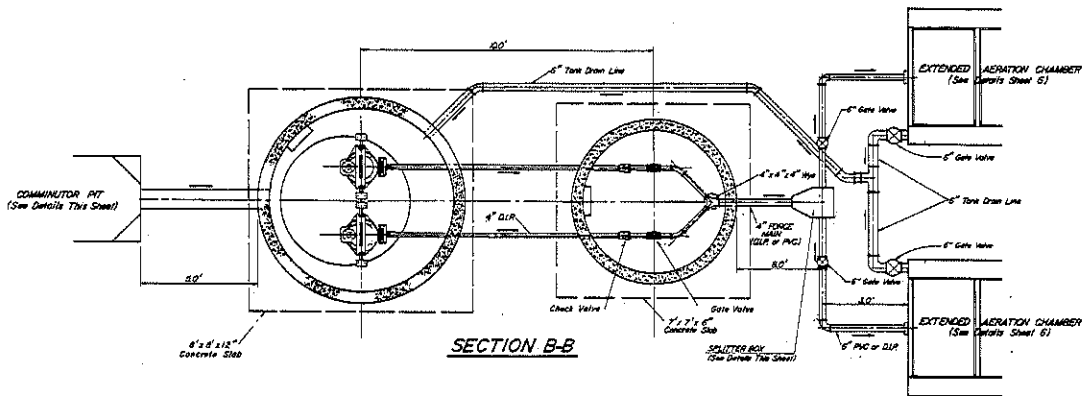

COMMINUTOR PIT DETAILS

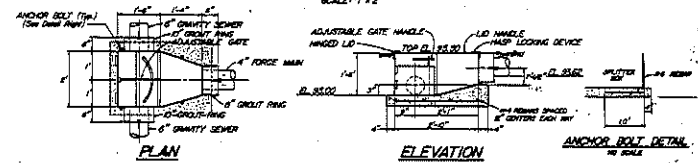

SPLITTER BOX DETAILS

AS - BUILT

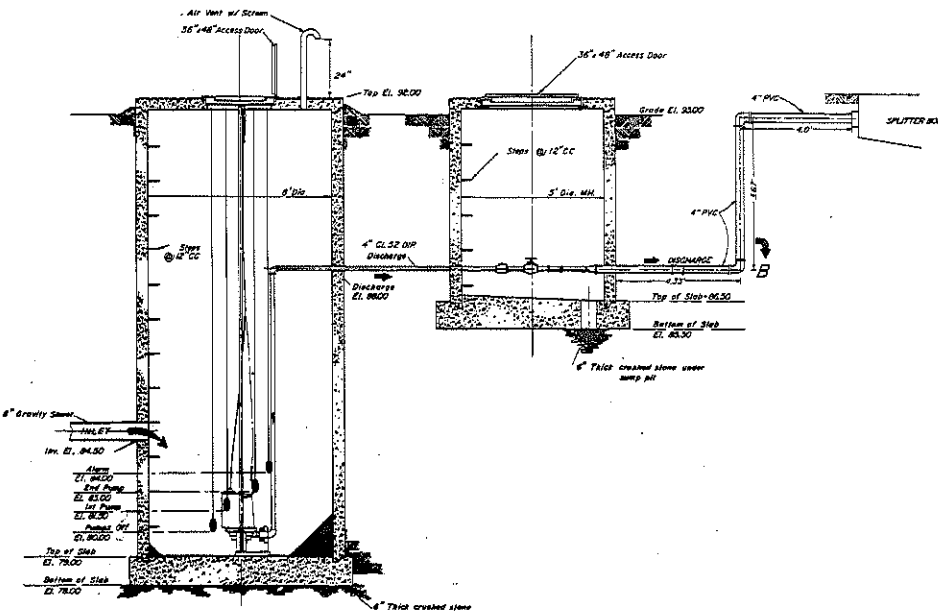

SECTION A-A
PUMP STATION DETAILS
NOT TO SCALE

REV.	DATE	DESCRIPTION	BY

DESIGNED BY	CVB, GWH	DATE	1-88
CHECKED BY	CVB	DATE	2-88
DRAWN BY	GWH	DATE	1-88
CHECKED BY	CVB	DATE	2-88
SURVEYED BY	JHC	DATE	11-27-87
BOOK NO.	151	PAGE	1-17

UNI-TEC, INC.
CONSULTING ENGINEERS
2041 CATO AVENUE
SUITE 201
STATE COLLEGE, PENNSYLVANIA 16801

SEWAGE TREATMENT PLANT EXPANSION
TURBOTVILLE BOROUGH
NORTHUMBERLAND COUNTY, PENNSYLVANIA
CONTRACT - 88-1

PUMP STATION DETAILS
COMMINUTOR PIT DETAILS
SPLITTER BOX DETAILS

SCALE
AS SHOWN
JOB NO.
E8770-LB.3
SHEET NO.
7 of 7

0470133000

Appendix B – Pilot Study Drawing Sheets

LEGEND

- PROPOSED SANITARY SEWER w/ PROPOSED MANHOLE
- EXISTING SANITARY SEWER w/ EXISTING MANHOLE
- - - - SANITARY SEWER TO BE ABANDONED
- - - - SANITARY SEWER TO BE ABANDONED
- - - - EXISTING 4" WATER LINE
- - - - WATER LINE TO BE ABANDONED
- - - - WATER LINE TO BE ABANDONED
- - - - EXISTING WATER SERVICE LATERAL
- - - - CHLORINE SOLUTION LINE TO BE REMOVED
- - - - EMERGENCY OVERFLOW LINE TO BE ABANDONED
- - - - TEMPORARY SANITARY SEWER
- - - - TREATMENT PLANT PIPING w/ VALVE
- - - - POWER LINE AND POLE
- - - - EXISTING FENCE
- - - - EXISTING FENCE TO BE RELOCATED
- - - - PROPOSED FENCE
- - - - PROPERTY LINE

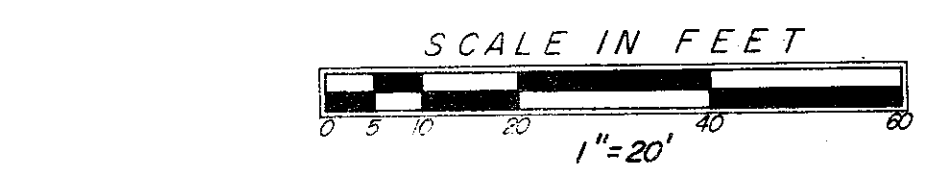
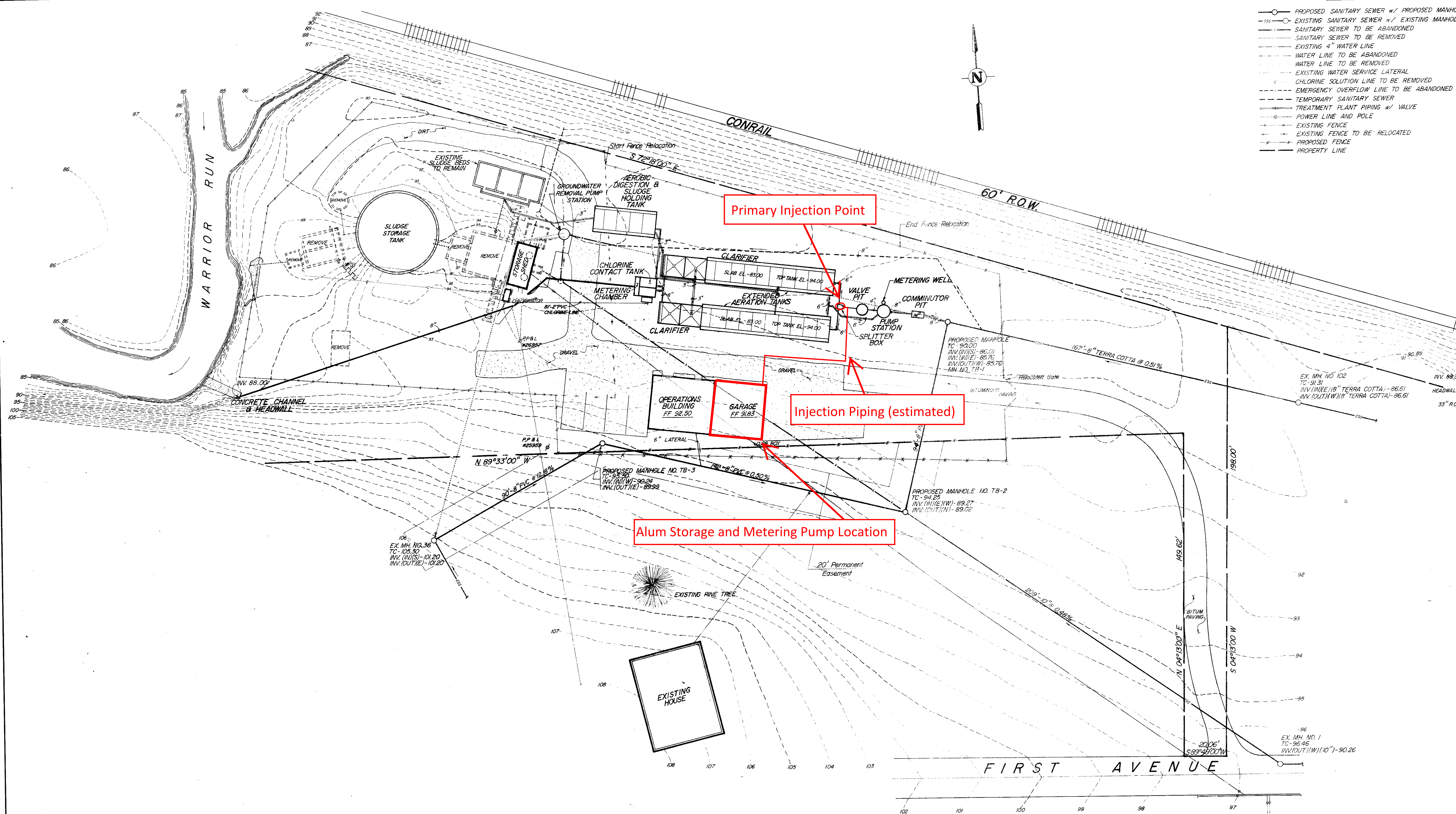

REV.	DATE	DESCRIPTION	BY
2	8-12-88	REV. OPERATIONS BLDG.	CJW
1	7-22-88	ADDED METERING CHAMBER	CJW

DESIGNED BY	CVB/CJW	DATE	2-88
CHECKED BY	CVB	DATE	2-88
DRAWN BY	CJW	DATE	2-88
CHECKED BY	CVB	DATE	2-88
SURVEYED BY	THG	DATE	11-27-87
BOOK NO.	151	PAGE	1-17
DISC. NO.	58		

UNI-TEC, INC.
 CONSULTING ENGINEERS
 2041 CATO AVENUE
 SUITE 201
 STATE COLLEGE, PENNSYLVANIA 16801

SEWAGE TREATMENT PLANT EXPANSION
 TURBOTVILLE BOROUGH
 NORTHUMBERLAND COUNTY, PENNSYLVANIA
 CONTRACT 88-1

AS - BUILT

SCALE
 1" = 20'

DRAWING NO.
 E87170-1.B.3

SHEET NO.
 4 OF 4

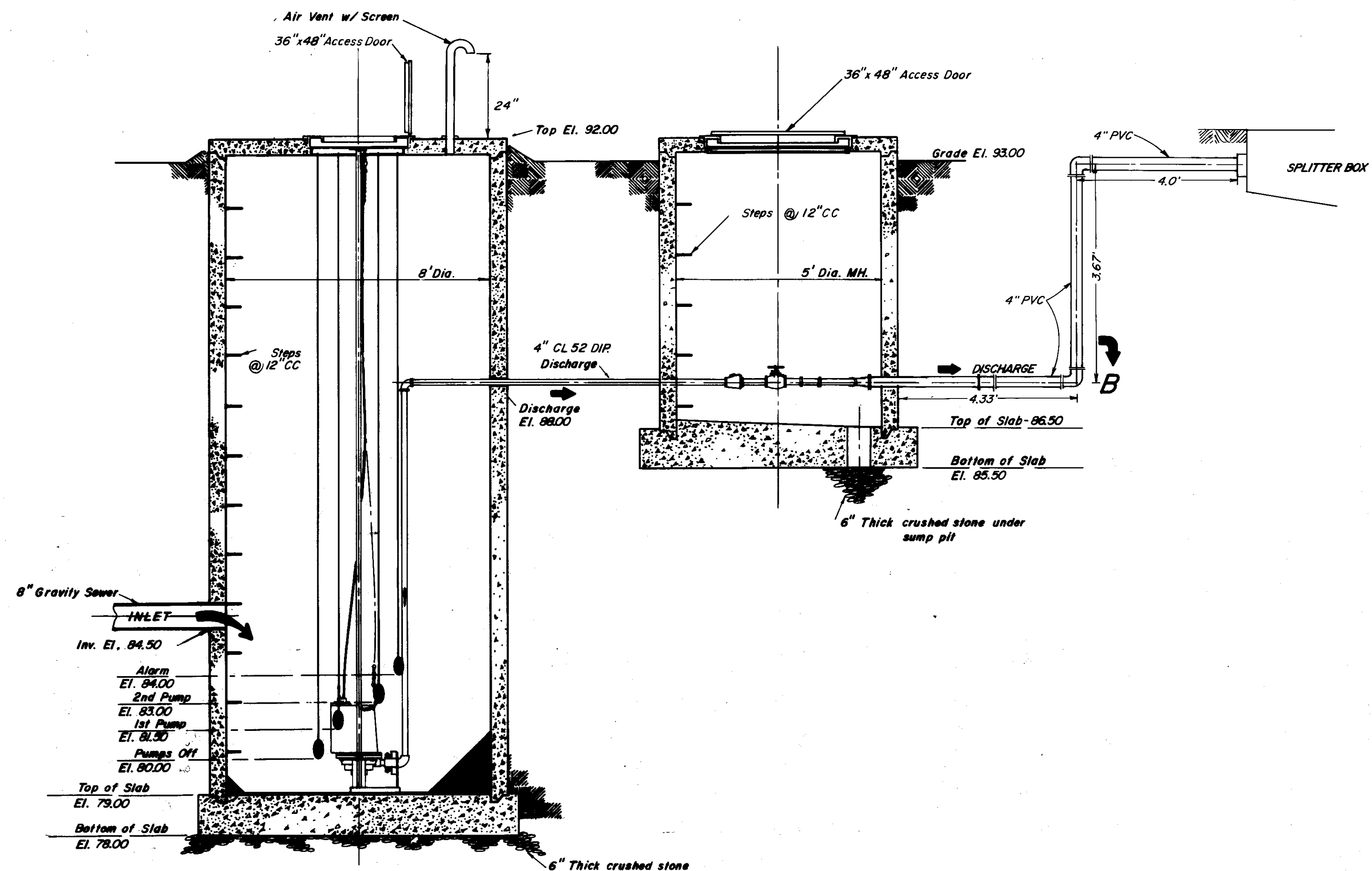
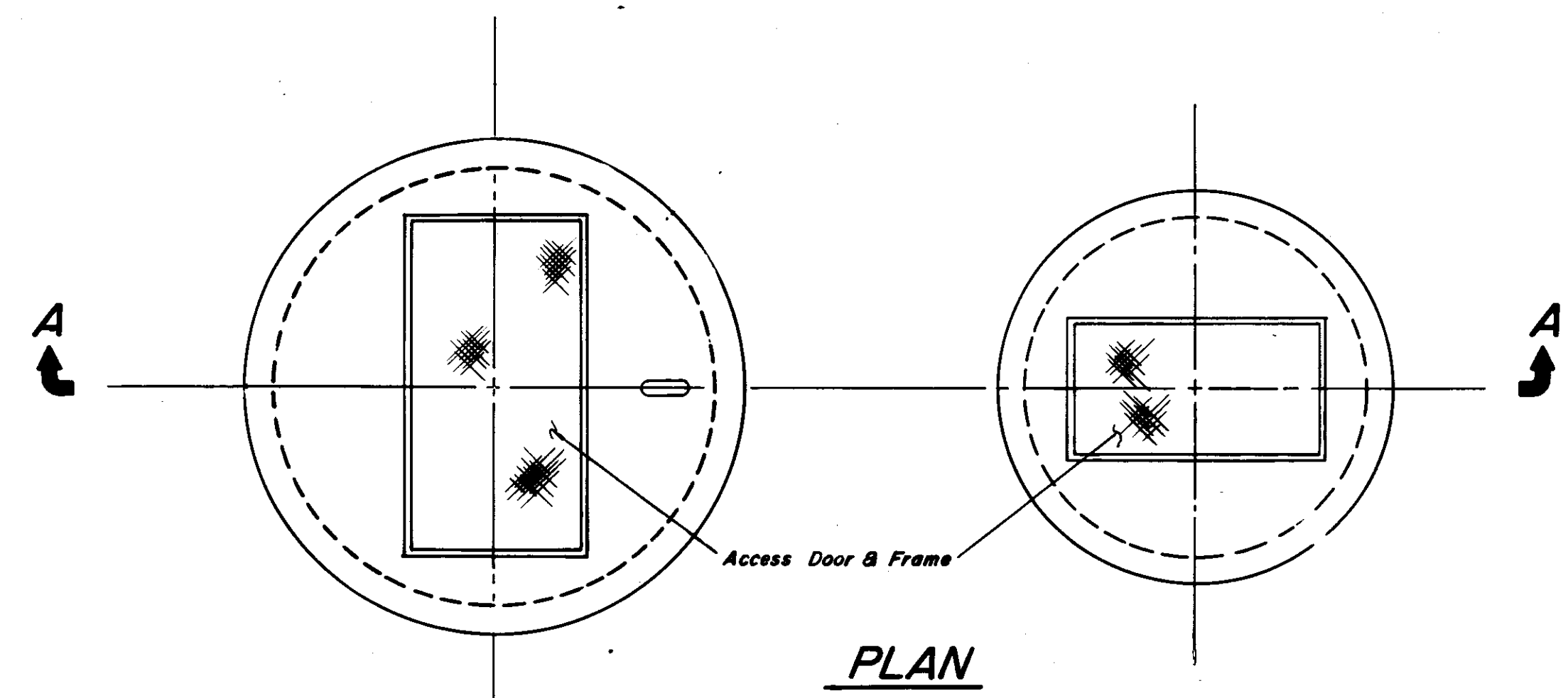
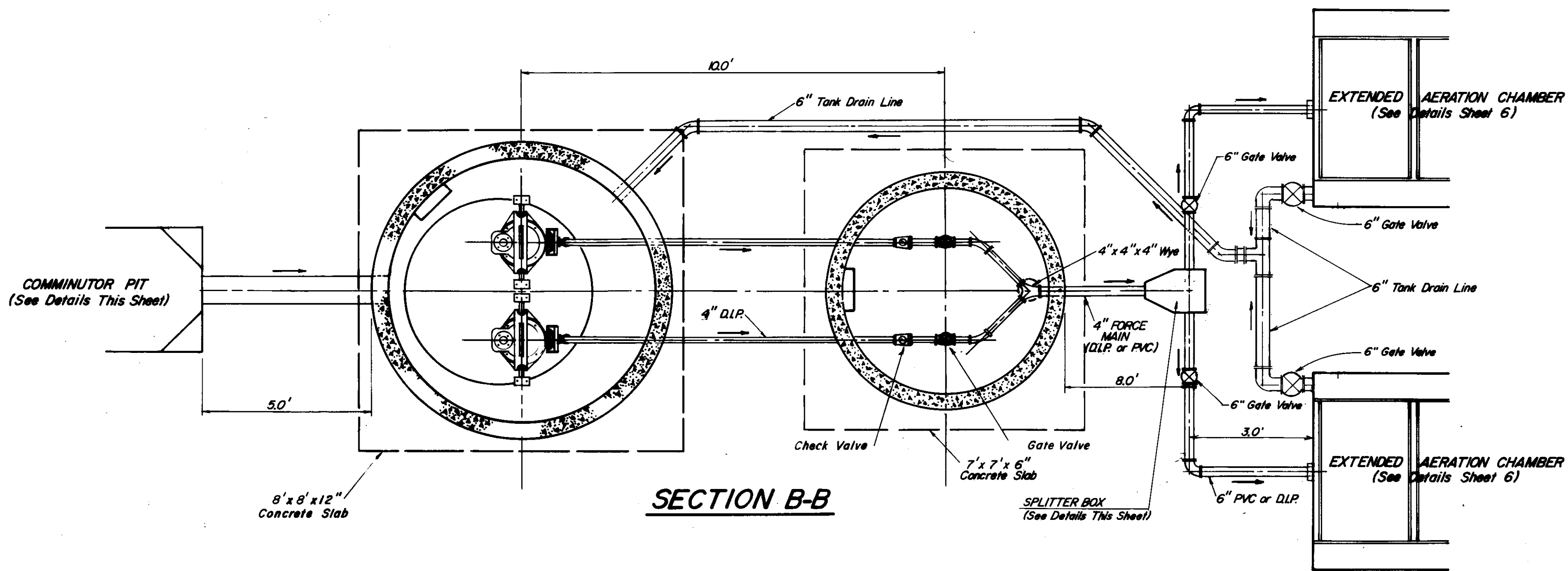

SECTION A-A
PUMP STATION DETAILS
NOT TO SCALE

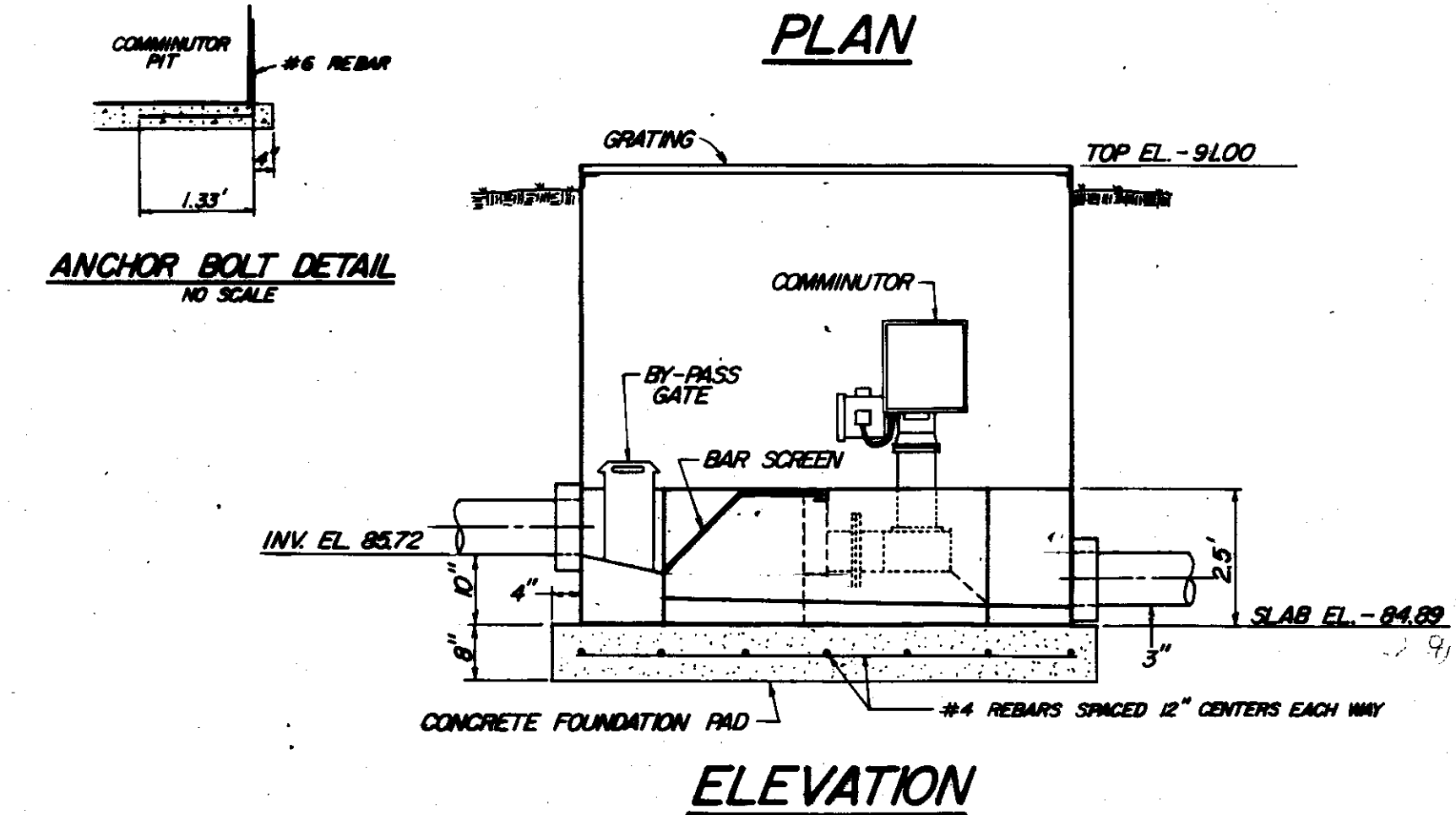
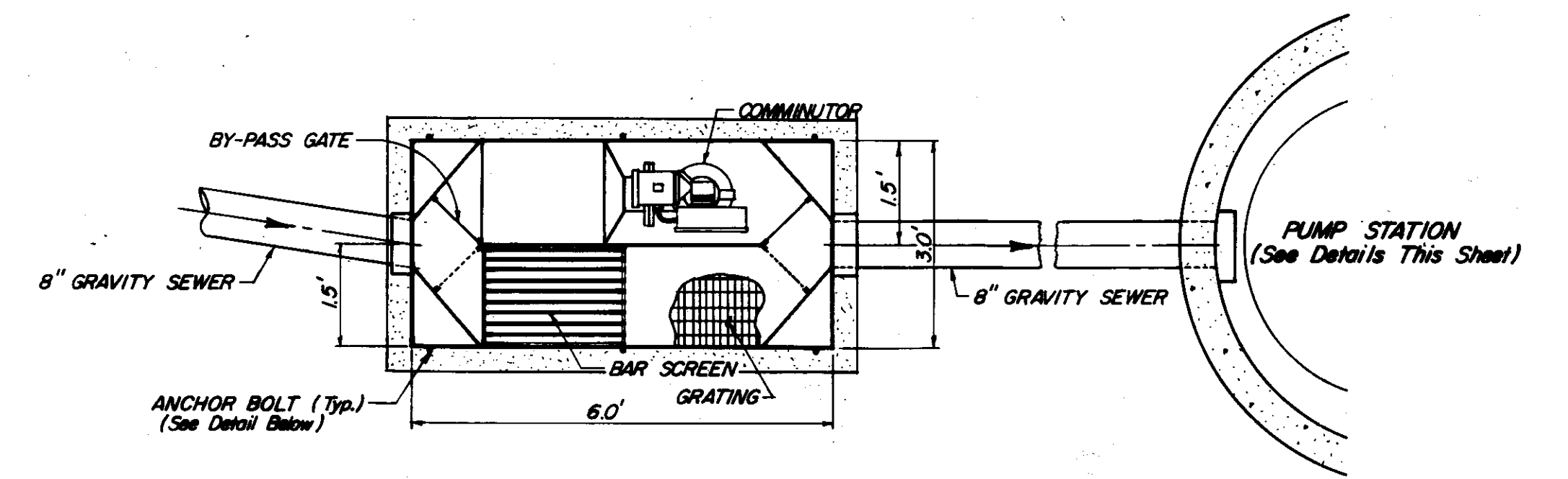

COMMINUTOR PIT DETAILS
SCALE: 1"=2'

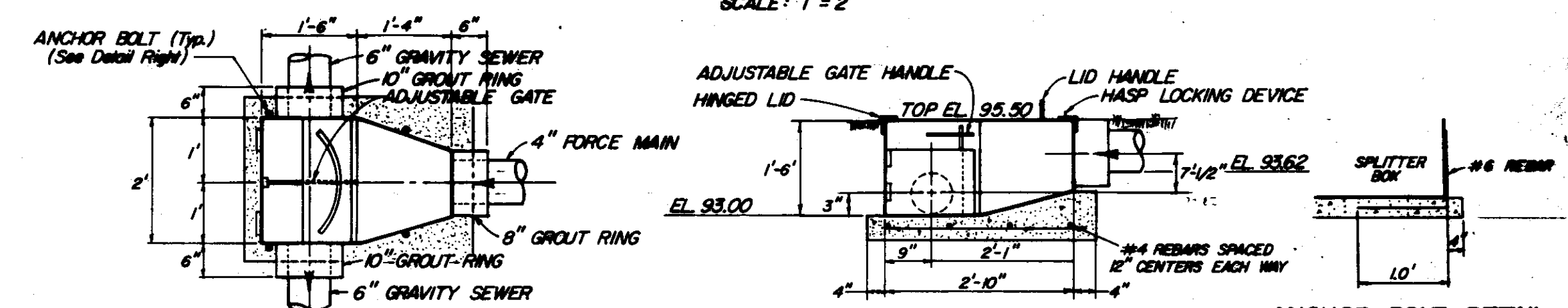

SPLITTER BOX DETAILS
NOT TO SCALE

REV.	DATE	DESCRIPTION	BY

DESIGNED BY	CVB, CJW	DATE	1-88
CHECKED BY	CVB	DATE	2-88
DRAWN BY	CJW	DATE	1-88
CHECKED BY	CVB	DATE	2-88
SURVEYED BY	THG	DATE	11-27-87
BOOK NO.	151	PAGE	1-17

UNI-TEC, INC.
CONSULTING ENGINEERS
2041 CATO AVENUE
SUITE 201
STATE COLLEGE, PENNSYLVANIA 16801

SEWAGE TREATMENT PLANT EXPANSION
TURBOTVILLE BOROUGH
NORTHUMBERLAND COUNTY, PENNSYLVANIA
CONTRACT 88-1

PUMP STATION DETAILS
COMMINUTOR PIT DETAILS
SPLITTER BOX DETAILS

SCALE	AS SHOWN
JOB NO.	EB770-1.B.3
SHEET NO.	7
OF	7

Appendix C – Dosage Rate Data

Weekly Analysis Results
Turbotville WWTP Phosphorus Removal Pilot Study

NPDES Phosphorus Effluent Limit (mg/L) = 2.6

Week of	Effluent Phosphorus Concentration (mg/L)	Was the effluent requirement met?	Average Dosage Rate for the Week (mL/min)
6/7/2018	0.154	YES	45
6/13/2018	0.250	YES	46
6/20/2018	0.050	YES	45
6/27/2018	0.105	YES	42
7/3/2018	0.057	YES	37
7/11/2018	0.165	YES	38
7/18/2018	0.050	YES	37
7/26/2018	0.455	YES	35
8/1/2018	0.063	YES	34
8/8/2018	0.154	YES	34
8/16/2018	0.757	YES	34
8/22/2018	0.050	YES	29
8/29/2018	0.105	YES	29
9/5/2018	0.270	YES	27
9/12/2018	0.290	YES	24
9/20/2018	0.068	YES	23
9/27/2018	1.060	YES	19
10/4/2018	0.472	YES	19
10/10/2018	0.214	YES	19
10/17/2018	0.239	YES	19
10/24/2018	0.239	YES	19

Appendix D – Dosage Rate Graph

Turbotville WWTP Pilot Study Results

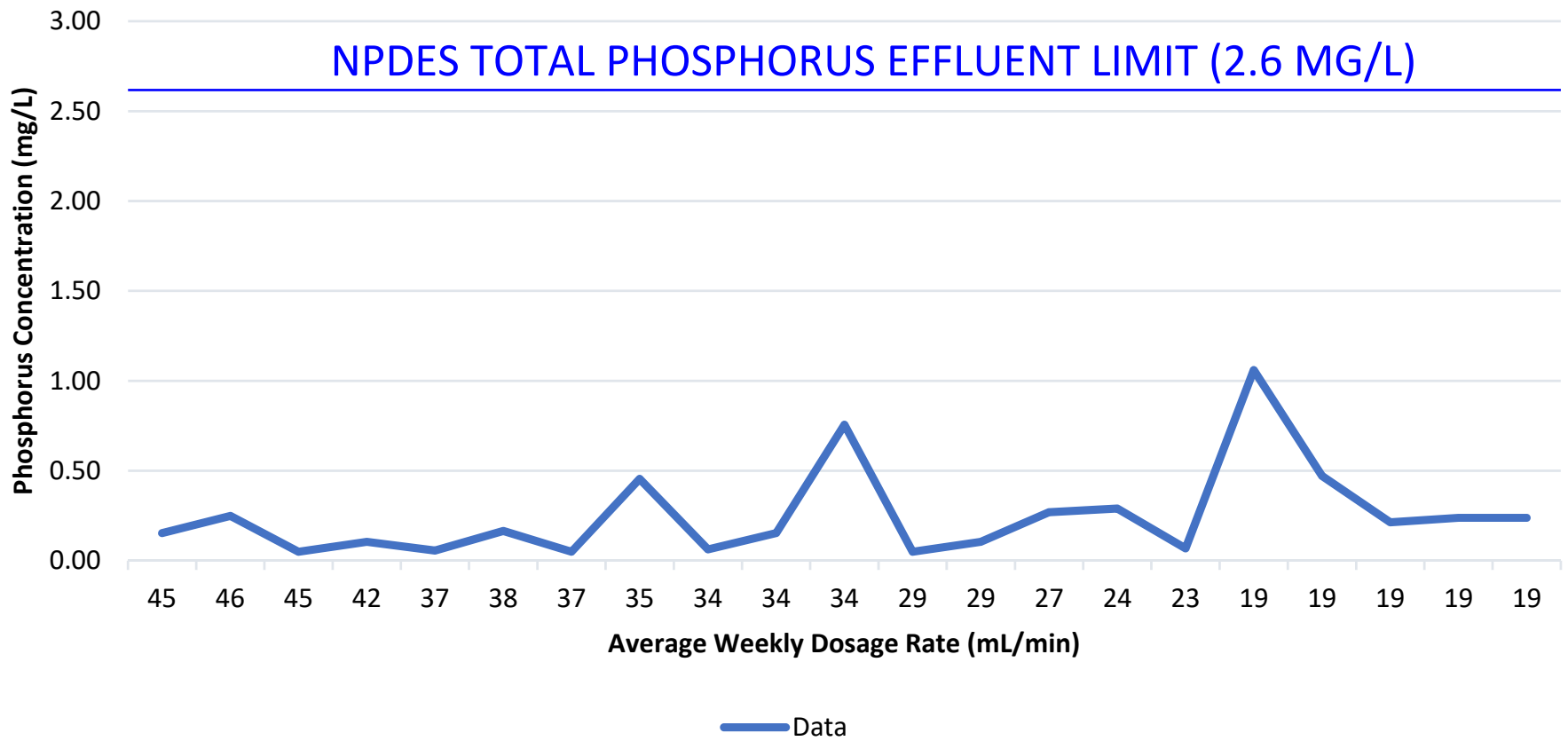

December 3, 2018

CERTIFIED MAIL NO. 7015 1730 0000 7751 5201

Francis Betz
Turbotville Borough
PO Box 264
2 Adam Street
Turbotville, PA 17772-0264

Re: Phosphorus Removal Pilot Study
Turbotville Borough Wastewater Treatment Plant
NPDES Permit No. PA0028100 A-1
Turbotville Borough, Northumberland County

Dear Mr. Betz:

On November 29, 2018, the Department received the Final Report for the Phosphorus Removal Pilot Study prepared by Uni-Tec Consulting Engineers, Inc. As you are aware, the Phosphorus Removal pilot study was temporarily authorized, with caveats, by the Department on May 31, 2018. The temporary authorization ended on October 31, 2018, and no further authorization to utilize this “pilot” process is granted.

Within the final report, Part VI. Schedule of Permanent Installation, your consultant states that the system “shall be maintained during the design/permitting/construction of permanent installation.” As noted above, Turbotville Borough has no authorization to continue this “pilot” study and does so at your own liability.

Part VI. Schedule of Permanent Installation, further states that a Water Quality Management Permit application will be submitted in approximately 90 days. As you are aware, Turbotville Borough, through the Act 537 planning process, has approved the construction of a new Wastewater Treatment Plant and the current “pilot” study treatment has not been approved through that process which includes alternative analysis and public participation provisions. The Department cannot issue a permit for this process without the Act 537 plan being approved for this form of treatment. If Turbotville Borough believes that this treatment process should be utilized, a revision to the Act 537 plan is necessary first.

Additionally, your NPDES Permit No. PA0028100 contains the following compliance schedule:

I. SCHEDULE OF COMPLIANCE

A. The permittee shall achieve compliance with final effluent limitations or terminate this discharge in accordance with the following schedule:

1. Final design completion

October 1, 2016

- | | |
|---|---------------------|
| 2. Obtain all necessary permits | <u>June 1, 2017</u> |
| 3. Complete construction and compliance with effluent limitations | <u>June 1, 2018</u> |

As you are aware, Turbotville is in noncompliance with this schedule. As you are also aware, Uni-Tec Consulting Engineers submitted a request to withdraw the WQM application and subsequently submitted a schedule to provide a path forward to rectify this continuing noncompliance on October 31, 2017. On November 17, 2017, the Department accepted this schedule as meeting the noncompliance notification requirement contained in NPDES Permit PA0028100. See attached. This letter stated the Department's concerns and provided guidance.

In summation, Turbotville Borough continues to be in noncompliance with their NPDES permit and their Act 537 plan.

Please be advised that continued noncompliance will lead to increased civil penalty liability under The Clean Streams Law. Escalated enforcement actions may be pursued by the Department if you fail to remedy the above-mentioned violation.

This notice of violation is neither an order nor any other final action of the Department of Environmental Protection. It neither imposes nor waives any enforcement action available to the Department under any of its statutes. If the Department determines that an enforcement action is appropriate, you will be notified of the action.

If you have any questions, you may contact me at 570.327.0530 or by email at trandis@pa.gov.

Sincerely,



Thomas M. Randis
Environmental Program Manager
Clean Water Program

Enclosures

cc: Daniel Thetford
Anne Hughes
Amy Gresh
Uni-Tec Consulting Engineers, Inc.
Operations Section
File



pennsylvania
DEPARTMENT OF ENVIRONMENTAL
PROTECTION

November 17, 2017

Turbotville Borough Council
Attn: Brentha Snyder, Secretary
1st Street, P.O. Box 264
Turbotville, PA 17772

Re: NPDES Permit No. PA0028100 Compliance Status Update
Turbotville Borough Wastewater Treatment Plant
Turbotville Borough, Northumberland County

Dear Council Members:

The Department of Environmental Protection (DEP) has reviewed the October 31, 2017 compliance status update contained in correspondence submitted by Uni-tec Consulting Engineers on your behalf. In general, the Department considers this correspondence to meet the noncompliance notification requirements of the Part C. III. B. condition contained in your NPDES Permit No. PA0028100.

As you are aware, Turbotville Borough's approved Act 537 plan requires the existing Turbotville Borough sewage treatment plant to be upgraded to include two (2) Sequencing Batch Reactor (SBR) tanks for all biological treatment, an influent triplex pump station and grinder, chemical feed systems, a post-equalization basin, two (2) aerobic sludge digesters, an ultraviolet disinfection system, an emergency generator, and an alternate system for sludge dewatering and disposal facilities. This Act 537 plan is still valid.

Additionally, Turbotville Borough submitted and subsequently withdrew a WQM application for this project to meet the schedule contained in the Act 537 plan as well as meet the Part C. III. A. schedule of compliance.

At this time, the Department considers the October 31, 2017 correspondence to be an appropriate substitute for the compliance schedule contained in Part C. III. A; however, the correspondence does not meet the approved Act 537 plan. It should be noted that there is significant concern by the Department that the schedule is not achievable once WQM permitting and revised Act 537 timeframes are accounted for in the schedule.

As a reminder, the NPDES revised effluent limits will go into effect June 1, 2018 and cannot be revised to a later date.

In an effort to move forward with the stated goals of Turbotville Borough in regards to NPDES compliance, ownership of the sewage collection and treatment facility as well as the revision of the Act 537 plan, the Department advises the following occur: Provide bi-monthly (60 day) updates to the Department concerning the sale of the system, the schedule to revise the Act 537 plan, a description of the operational process that will be used to meet the Ammonia and Copper limits and the schedule to submit a WQM for the treatment of Phosphorus.

Notes to consider, the Department cannot issue a WQM permit if it does not meet the approved Act 537 plan but can review them concurrently. It is important the Act 537 plan be revised in an expeditious manner. As the effluent limit compliance dates cannot be changed and it is unlikely that Act 537 planning will be completed before that date, I recommend that your consulting engineer explore other temporary options at the facility that may be approvable on an equally temporary basis.

If you have any questions or concerns, please contact me directly at trandis@pa.gov or 570.327.0530.

Sincerely,



Thomas M. Randis
Environmental Program Manager
Clean Water Program

cc: Anne Hughes
Daniel Thetford
Jere Northridge, PE
Michael Jordan
Amy Gresh
Michele Aukerman, PE, Uni-tec
File

Appendix E

Memorandum of Understanding between Lewis Township and Pennsylvania-American Water Company

MEMORANDUM OF UNDERSTANDING

THIS MEMORANDUM OF UNDERSTANDING ("MOU"), executed this 6th day of February, 2019, by and between the Township of Lewis, Northumberland County, Pennsylvania, with a current address of P.O. Box 143, Watsonstown, Pennsylvania (hereinafter "**Lewis Township**") and Pennsylvania - American Water Company, with a corporate address of 800 W. Hershey Park Drive Hershey, Pennsylvania 17033 (the "**PAWC**").

WITNESSETH:

WHEREAS, Lewis Township and the Borough of Turbotville, Northumberland County, Pennsylvania, having a current address of P. O. Box 246, Turbotville, Pennsylvania (hereinafter "**Turbotville**"), previously entered into an "Inter-Municipal Wastewater Agreement" dated January 31, 2011, whereby, among other things, Lewis Township agreed to purchase reserved capacity for the SR 54 Corridor (as depicted in the attached **Exhibit 1**, the "**SR 54 Corridor**") and Schell & Koch Road area ("**Schell & Koch**"). The Inter-Municipal Wastewater Agreement is hereinafter referred to as the "**Wastewater Agreement**";

WHEREAS, since the execution of the Wastewater Agreement, the installation of facilities within either SR 54 Corridor or Schell & Koch has never materialized, and on March 31, 2017, Turbotville issued an advertisement for the sale of their wastewater treatment plant and collection system located exclusively within Turbotville's municipal boundaries ("**System Assets**");

WHEREAS, PAWC and Turbotville subsequently negotiated and entered into an Asset Purchase Agreement ("**APA**") on June 29, 2018; which PAWC has filed with its Application with the Pennsylvania Public Utility Commission ("**PUC**") on August 20, 2018 (Docket A-2018-3004189), and as of the date of this MOU the PUC has yet to issue its Order approving PAWC's Application, which is required for the transaction between PAWC and Turbotville to close;

WHEREAS; the APA provides that, among other things, PAWC will purchase the System Assets and that the Wastewater Agreement be terminated;

WHEREAS, concurrently with the negotiations of the APA, Lewis Township determined that it would be in the best interest of Lewis Township if Schell & Koch was serviced by Lewis Township's wastewater treatment plant and the SR 54 Corridor was serviced by the Turbotville plant, and Lewis Township has since filed with the Pennsylvania Department of Environmental Protection ("**DEP**") its amended 537 Plan reflecting this change;

WHEREAS, Lewis Township also, concurrently with PAWC's negotiations of the APA with Turbotville, entered into a "Memorandum of Understanding" with Turbotville on April 19, 2018, whereby Lewis Township and Turbotville agreed that it was in the best interest of Lewis Township if Schell & Koch was serviced by Lewis Township's wastewater treatment plant (the "**Turbotville MOU**"); and

WHEREAS, the Turbotville MOU stated among other things that, subject to DEP approval, (1) Lewis Township would prepare a 537 Plan Amendment to indicate that the Schell & Koch sewage would be treated by Lewis Township's wastewater treatment plant, but that the planning for the SR 54 Corridor would not change; (2) Turbotville shall adopt the 537 Plan Amendment, thereby modifying its own 537 Plan eliminating Schell & Koch; (3) Turbotville will work diligently with Lewis Township and PAWC to obtain a commitment by PAWC to provide bulk wastewater treatment service to Lewis Township for the SR 54 Corridor in the future, in accordance with current 537 planning and (4) that future bulk wastewater treatment service to the SR 54 Corridor shall be negotiated between Lewis Township and PAWC and based upon the published PAWC Tariff(s) in effect at the time of negotiation;

WHEREAS, the Turbotville MOU further states that Lewis Township will not agree to terminate the Wastewater Agreement until all of the terms and conditions of the Turbotville MOU have been satisfied; and

WHEREAS, the parties to this MOU desire to set forth the understanding of the parties relating to PAWC providing bulk wastewater treatment service to the SR 54 Corridor as depicted in **Exhibit 1** attached hereto in the future based upon its then published Tariff(s) in effect at the time of negotiation of the bulk wastewater treatment agreement.

NOW, THEREFORE, in consideration of the covenants contained herein and intending to be legally bound, the parties hereto agree as follows:

1. The recitals above are herein fully incorporated into this MOU.
2. It is agreed by the parties that Lewis Township is solely responsible for providing service to its residents within Area B of **Exhibit 1** attached hereto; and that if requested by Lewis Township, the parties will enter into negotiations for a bulk wastewater service agreement whereby Lewis Township will pay a capacity reservation fee if required by PAWC's Tariff and the sewage from the SR 54 Corridor - which is anticipated to include typical residential strength flow from 17 single family residential homes - will flow to through the System Assets for treatment at the Turbotville wastewater treatment plant as a component included in the System Assets.
3. Subject to DEP's approval, Lewis Township's responsibility for providing wastewater collection service to its residents within Area B of **Exhibit 1** shall include i) engineering and design of the system to be approved by PAWC (main and laterals from the main to each property abutting Rte 54) from Warrior Run Road to and including the connection to an adequately sized wastewater collection main within the System Assets; ii) engineering and design of an appropriately sized meter pit located along Rte 54 where PAWC's PUC Certificated Service Area intersects with Rte 54 (see red-dot on **Exhibit 1**); iii) providing all the necessary funding for items "i" and "ii" and dedicating those facilities installed within PAWC's PUC Certificated Service Area (excluding the meter pit) to PAWC; and (iv) any other requirements reasonably determined by PAWC to be necessary.
4. The parties further agree that within thirty (30) days of Lewis Township providing written notice to PAWC of its intent under Sections 2 and 3 above, the parties shall negotiate in good faith a bulk wastewater treatment service agreement subject to PAWC's published Tariff(s) in effect at that time. Lewis Township shall pay any capacity reservation fee if required by PAWC's Tariff. PAWC shall furnish, at its sole cost, the appropriate meter within the meter pit noted in Section 3 above.
5. The parties further acknowledge and agree that any service provided in accordance with the bulk wastewater treatment service agreement shall be subject to any changes, amendments or revisions to the Act 537 Plans of both Lewis Township and Turbotville Borough, which such changes, amendments or revisions they may seek in their sole discretion, and that the wastewater treatment service agreement must be approved by the PUC and the Act 537 Plans must be approved by the DEP.
6. This MOU may be executed by facsimile, electronically or by exchange of documents in PDF format, and in several counterparts, each of which will be deemed an original instrument and all of which together shall constitute a single agreement.

IN WITNESS WHEREOF, the parties hereunto set their hands and seals on this 6th day of February, 2019.

ATTEST:

LEWIS TOWNSHIP
Northumberland County, Pennsylvania

By: 

By: 

ATTEST:

**PENNSYLVANIA - AMERICAN WATER
COMPANY**

By: 

By: 
Its: President 2/21/19

EXHIBIT 1
SR 54 CORRIDOR

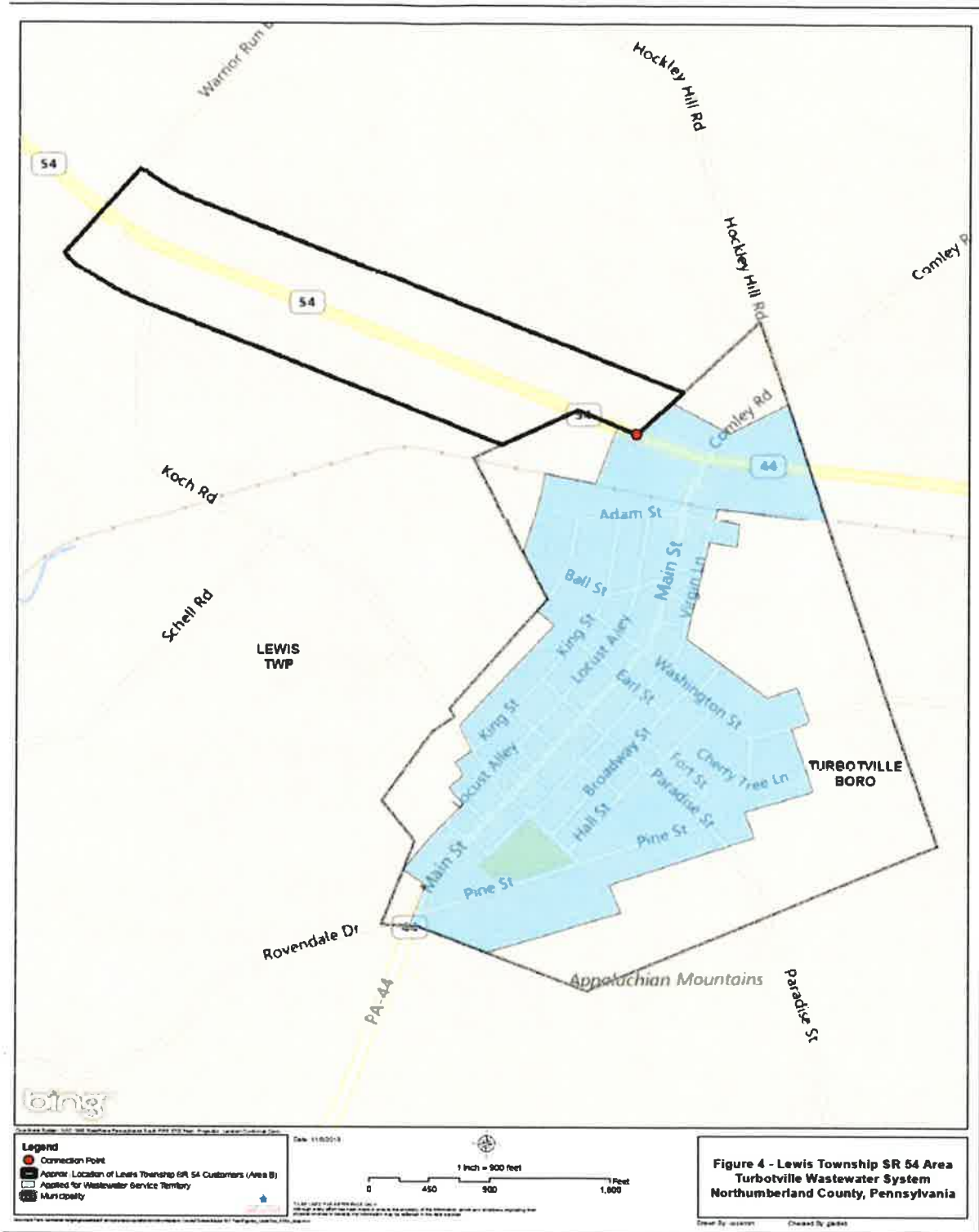

Appendix F
Completed and Signed Pennsylvania Natural Diversity
Inventory Receipt

1. PROJECT INFORMATION

Project Name: **Act537 plan Turbotville WWTP upgrade**

Date of Review: **12/20/2018 04:31:47 PM**

Project Category: **Waste Transfer, Treatment, and Disposal, Liquid waste/Effluent, Sewage module/Act 537 plan**

Project Area: **0.84 acres**

County(s): **Northumberland**

Township/Municipality(s): **TURBOTVILLE**

ZIP Code: **17772**

Quadrangle Name(s): **MILTON**

Watersheds HUC 8: **Lower West Branch Susquehanna**

Watersheds HUC 12: **Warrior Run**

Decimal Degrees: **41.106496, -76.771931**

Degrees Minutes Seconds: **41° 6' 23.3855" N, 76° 46' 18.9522" W**

2. SEARCH RESULTS

Agency	Results	Response
PA Game Commission	No Known Impact	No Further Review Required
PA Department of Conservation and Natural Resources	No Known Impact	No Further Review Required
PA Fish and Boat Commission	No Known Impact	No Further Review Required
U.S. Fish and Wildlife Service	No Known Impact	No Further Review Required

As summarized above, Pennsylvania Natural Diversity Inventory (PNDI) records indicate no known impacts to threatened and endangered species and/or special concern species and resources within the project area. Therefore, based on the information you provided, no further coordination is required with the jurisdictional agencies. This response does not reflect potential agency concerns regarding impacts to other ecological resources, such as wetlands.

Act537 plan Turbotville WWTP upgrade



- Project Boundary
- Buffered Project Boundary

Service Layer Credits: Sources: Esri, HERE, DeLorme, Intermap, increment P Corp., GEBCO, USGS, FAO, NPS, NRCAN, GeoBase, IGN, Kadaster NL, Ordnance Survey, Esri Japan, METI, Esri China (Hong Kong), swisstopo, MapmyIndia, © OpenStreetMap contributors, and the GIS User Community
Esri, HERE, Garmin, © OpenStreetMap contributors, and the GIS user community

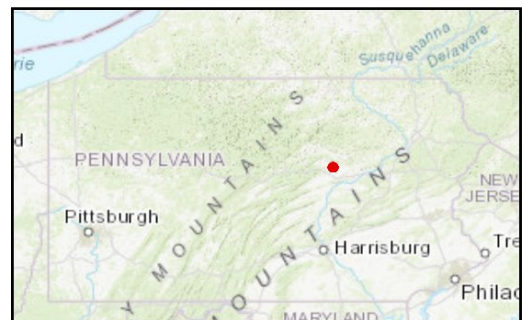

Act537 plan Turbotville WWTP upgrade

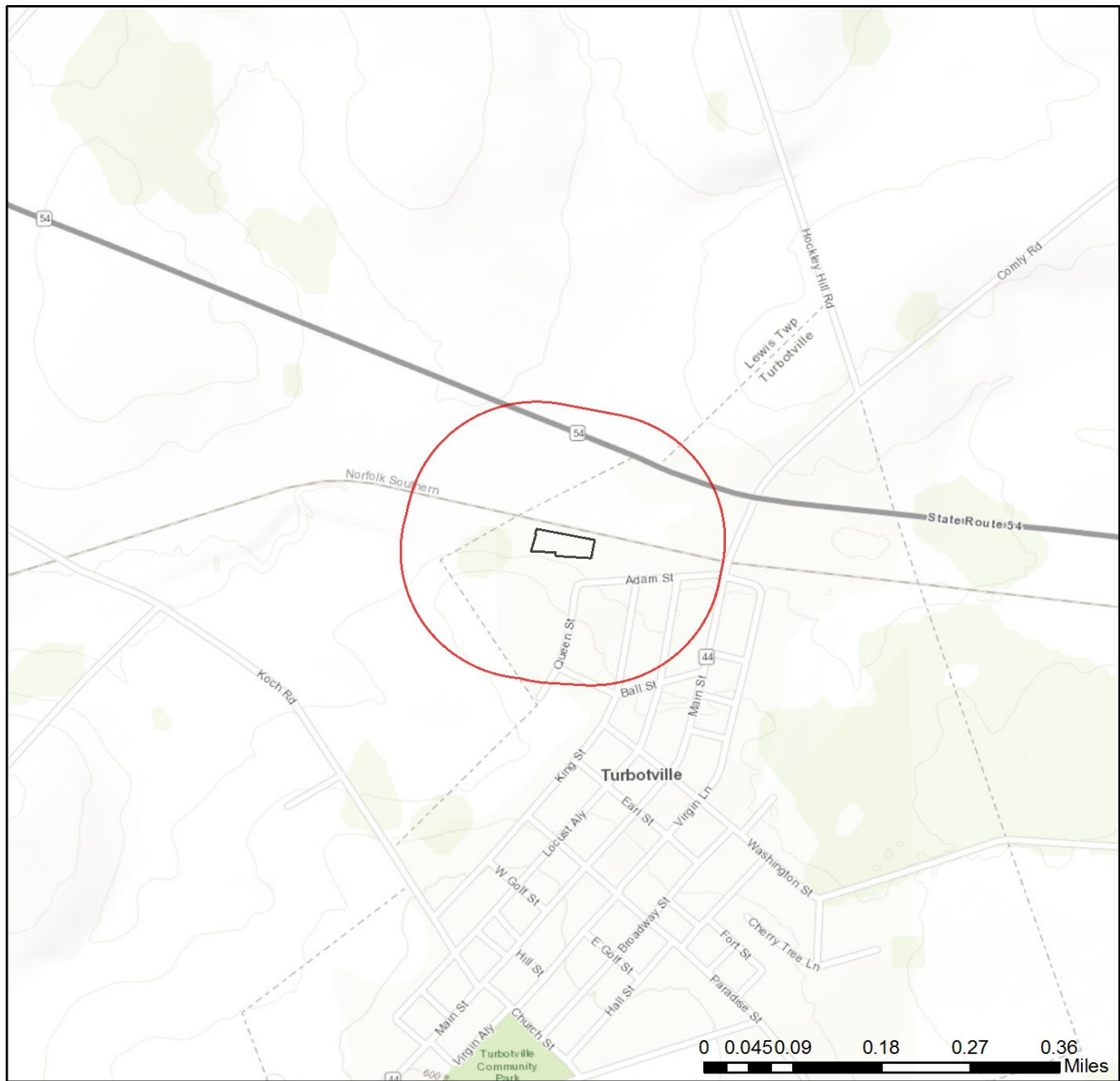

- Project Boundary
- Buffered Project Boundary

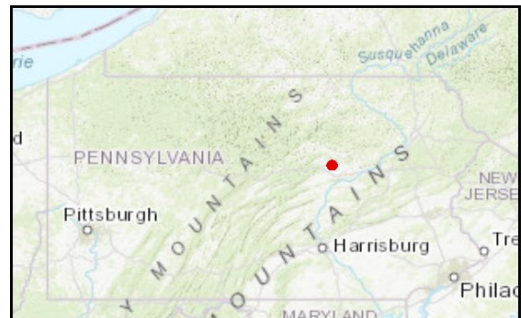

Service Layer Credits: Sources: Esri, HERE, DeLorme, Intermap, increment P Corp., GEBCO, USGS, FAO, NPS, NRCAN, GeoBase, IGN, Kadaster NL, Ordnance Survey, Esri Japan, METI, Esri China (Hong Kong), swisstopo, MapmyIndia, © OpenStreetMap contributors, and the GIS User Community
 Sources: Esri, HERE, Garmin, Intermap, increment P Corp., GEBCO, USGS, FAO, NPS,

3. AGENCY COMMENTS

Regardless of whether a DEP permit is necessary for this proposed project, any potential impacts to threatened and endangered species and/or special concern species and resources must be resolved with the appropriate jurisdictional agency. In some cases, a permit or authorization from the jurisdictional agency may be needed if adverse impacts to these species and habitats cannot be avoided.

These agency determinations and responses are **valid for two years** (from the date of the review), and are based on the project information that was provided, including the exact project location; the project type, description, and features; and any responses to questions that were generated during this search. If any of the following change: 1) project location, 2) project size or configuration, 3) project type, or 4) responses to the questions that were asked during the online review, the results of this review are not valid, and the review must be searched again via the PNDI Environmental Review Tool and resubmitted to the jurisdictional agencies. The PNDI tool is a primary screening tool, and a desktop review may reveal more or fewer impacts than what is listed on this PNDI receipt. The jurisdictional agencies **strongly advise against** conducting surveys for the species listed on the receipt prior to consultation with the agencies.

PA Game Commission

RESPONSE:

No Impact is anticipated to threatened and endangered species and/or special concern species and resources.

PA Department of Conservation and Natural Resources

RESPONSE:

No Impact is anticipated to threatened and endangered species and/or special concern species and resources.

PA Fish and Boat Commission

RESPONSE:

No Impact is anticipated to threatened and endangered species and/or special concern species and resources.

U.S. Fish and Wildlife Service

RESPONSE:

No impacts to **federally** listed or proposed species are anticipated. Therefore, no further consultation/coordination under the Endangered Species Act (87 Stat. 884, as amended; 16 U.S.C. 1531 et seq. is required. Because no take of federally listed species is anticipated, none is authorized. This response does not reflect potential Fish and Wildlife Service concerns under the Fish and Wildlife Coordination Act or other authorities.

4. DEP INFORMATION

The Pa Department of Environmental Protection (DEP) requires that a signed copy of this receipt, along with any required documentation from jurisdictional agencies concerning resolution of potential impacts, be submitted with applications for permits requiring PNDI review. Two review options are available to permit applicants for handling PNDI coordination in conjunction with DEP's permit review process involving either T&E Species or species of special concern. Under sequential review, the permit applicant performs a PNDI screening and completes all coordination with the appropriate jurisdictional agencies prior to submitting the permit application. The applicant will include with its application, both a PNDI receipt and/or a clearance letter from the jurisdictional agency if the PNDI Receipt shows a Potential Impact to a species or the applicant chooses to obtain letters directly from the jurisdictional agencies. Under concurrent review, DEP, where feasible, will allow technical review of the permit to occur concurrently with the T&E species consultation with the jurisdictional agency. The applicant must still supply a copy of the PNDI Receipt with its permit application. The PNDI Receipt should also be submitted to the appropriate agency according to directions on the PNDI Receipt. The applicant and the jurisdictional agency will work together to resolve the potential impact(s). See the DEP PNDI policy at <https://conservationexplorer.dcnr.pa.gov/content/resources>.

5. ADDITIONAL INFORMATION

The PNDI environmental review website is a preliminary screening tool. There are often delays in updating species status classifications. Because the proposed status represents the best available information regarding the conservation status of the species, state jurisdictional agency staff give the proposed statuses at least the same consideration as the current legal status. If surveys or further information reveal that a threatened and endangered and/or special concern species and resources exist in your project area, contact the appropriate jurisdictional agency/agencies immediately to identify and resolve any impacts.

For a list of species known to occur in the county where your project is located, please see the species lists by county found on the PA Natural Heritage Program (PNHP) home page (www.naturalheritage.state.pa.us). Also note that the PNDI Environmental Review Tool only contains information about species occurrences that have actually been reported to the PNHP.

6. AGENCY CONTACT INFORMATION

PA Department of Conservation and Natural Resources

Bureau of Forestry, Ecological Services Section
400 Market Street, PO Box 8552
Harrisburg, PA 17105-8552
Email: RA-HeritageReview@pa.gov

U.S. Fish and Wildlife Service

Pennsylvania Field Office
Endangered Species Section
110 Radnor Rd; Suite 101
State College, PA 16801
NO Faxes Please

PA Fish and Boat Commission

Division of Environmental Services
595 E. Rolling Ridge Dr., Bellefonte, PA 16823
Email: RA-FBPACENOTIFY@pa.gov

PA Game Commission

Bureau of Wildlife Habitat Management
Division of Environmental Planning and Habitat Protection
2001 Elmerton Avenue, Harrisburg, PA 17110-9797
Email: RA-PGC_PNDI@pa.gov
NO Faxes Please

7. PROJECT CONTACT INFORMATION

Name: Ewoud Hulstein
Company/Business Name: Pennsylvania-American Water Company
Address: 852 Wesley Drive
City, State, Zip: Mechanicsburg, PA 17055
Phone: (717) 790-3045 Fax: ()
Email: ewoud.hulstein@amwater.com

8. CERTIFICATION

I certify that ALL of the project information contained in this receipt (including project location, project size/configuration, project type, answers to questions) is true, accurate and complete. In addition, if the project type, location, size or configuration changes, or if the answers to any questions that were asked during this online review change, I agree to re-do the online environmental review.

applicant/project proponent signature

12/20/2018
date

Appendix G
Cultural Resources Notice and PHMC Review

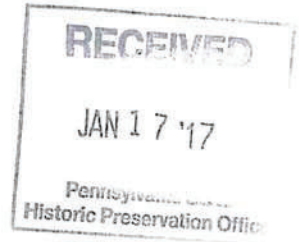

January 11, 2017
File No. 0047-043-000
Certified Mail No. 7015 1660 0000 9116 5187

Pennsylvania Historical and Museum Commission
Bureau of Historic Preservation
400 North Street, Second Floor
Harrisburg, PA 17120-0093

RE: Cultural Resource Notice
Act 537 Special Study
The Borough of Turbotville PA

Dear Pennsylvania Historical and Museum Commission:

The Borough of Turbotville is conducting an Act 537 Special Study. The study is to supplement the existing Act 537 in order to construct a new wastewater treatment plant, so that it will meet new effluent standards. The existing plant can be identified on the site plan attached to the file. On the site plan, the boundary of the project is outlined in red which encloses an area of 0.892 acres that will be utilized during the proposed project. The outline represents an existing fence that encloses the existing treatment plant. The proposed wastewater treatment plant will be constructed inside the red boundary on previously disturbed land. The confines of the fence limit the size and location of the project to within the outlined area.

The existing wastewater treatment plant consists of buildings located in the project area that were constructed in 1988. All of the buildings except for the Control Building will be demolished in order to make room for the new water treatment plant.

The remaining items have been attached per request of Section H. of the Cultural Resource Notice:

1. Cultural Resource Notice
2. 7.5' U.S.G.S. map indicating the defined boundary of the proposed activity
3. Return Receipt
4. Demolition Site Plan
5. Proposed Site Plan

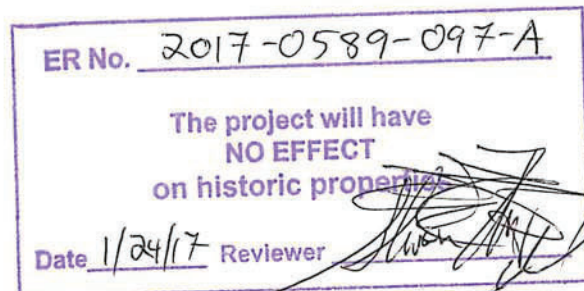

Should you have any questions or require additional information, please do not hesitate to contact me via email: gas@uni-tec.com or phone: (814) 238-8223 ext. 341

Sincerely,
UNI-TEC CONSULTING ENGINEERS, INC.

A handwritten signature in black ink, appearing to read "Garrett Stoy". The signature is fluid and cursive, with the first and last names being the most prominent.

Garrett A. Stoy
Project Engineer

GAS/gas

Email cc: Michele A. Aukerman, P.E. Uni-Tec Consulting Engineers, Inc.



CULTURAL RESOURCE NOTICE

DEP USE ONLY
Date Received

Read the instructions before completing this form.

SECTION A. APPLICANT IDENTIFIER	
Applicant Name	<u>The Borough of Turbotville</u>
Street Address	<u>2 Adam Street</u>
City	<u>Turbotville</u> State <u>Pennsylvania</u> Zip <u>17772</u>
Telephone Number	<u>(570) 649-5476</u>
Project Title	<u>Act 537 Special Study - Wastewater Treatment Plant Upgrade</u>
SECTION B. LOCATION OF PROJECT	
Municipality	<u>The Borough of Turbotville</u> County Name <u>Northumberland</u> DEP County Code <u>49</u>
SECTION C. PERMITS OR APPROVALS	
Name of Specific DEP Permit or Approval Requested:	**Water Quality Management Part II Anticipated
Anticipated federal permits:	
<input type="checkbox"/> Surface Mining	<input type="checkbox"/> 404 Water Quality Permit
<input type="checkbox"/> Army Corps of Engineers	<input type="checkbox"/> Federal Energy Regulatory Commission
<input type="checkbox"/> 401 Water Quality Certification	<input type="checkbox"/> Other: _____
SECTION D. GOVERNMENT FUNDING SOURCES N/A	
<input type="checkbox"/> State: (Name) _____	<input type="checkbox"/> Local: (Name) _____
<input type="checkbox"/> Federal: (Name) _____	<input type="checkbox"/> Other: (Name) _____
SECTION E. RESPONSIBLE DEP REGIONAL, CENTRAL, DISTRICT MINING or OIL & GAS MGMT OFFICE	
DEP Regional Office Responsible for Review of Permit Application	<input type="checkbox"/> Central Office (Harrisburg)
<input type="checkbox"/> Southeast Regional Office (Norristown)	<input type="checkbox"/> Northeast Regional Office (Wilkes-Barre)
<input type="checkbox"/> Southcentral Regional Office (Harrisburg)	<input checked="" type="checkbox"/> Northcentral Regional Office (Williamsport)
<input type="checkbox"/> Southwest Regional Office (Pittsburgh)	<input type="checkbox"/> Northwest Regional Office (Meadville)
<input type="checkbox"/> District Mining Office: _____	<input type="checkbox"/> Oil & Gas Office: _____
SECTION F. RESPONSIBLE COUNTY CONSERVATION DISTRICT, if applicable.	
County Conservation District	Telephone Number, if known
<u>Northumberland County Conservation District</u>	<u>(570) 495-4665</u>
SECTION G. CONSULTANT	
Consultant, if applicable	<u>Garrett A. Stoy</u>
Street Address	<u>2007 Cato Avenue</u>
City	<u>State College</u> State <u>Pennsylvania</u> Zip <u>16801</u>
Telephone Number	<u>(814) 238-8223 ext. 341</u>

SECTION H. PROJECT BOUNDARIES AND DESCRIPTION

REQUIRED

Indicate the total acres in the property under review. Of this acreage, indicate the total acres of earth disturbance for the proposed activity. -Acreage stated in Cover Letter

Attach a 7.5' U.S.G.S. Map indicating the defined boundary of the proposed activity. -Attached

Attach photographs of any building over 50 years old. Indicate what is to be done to all buildings in the project area. -Not Applicable

Attach a narrative description of the proposed activity. -Stated in Cover Letter

Attach the return receipt of delivery of this notice to the Pennsylvania Historical and Museum Commission. -Return Receipt Attached

REQUESTED

Attach photographs of any building over 40 years old. - Not Applicable

Attach site map, if available. -Site Map Attached

SECTION I. SIGNATURE BLOCK



Applicant's Signature

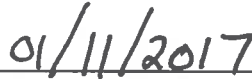

Date of Submission of Notice to PHMC

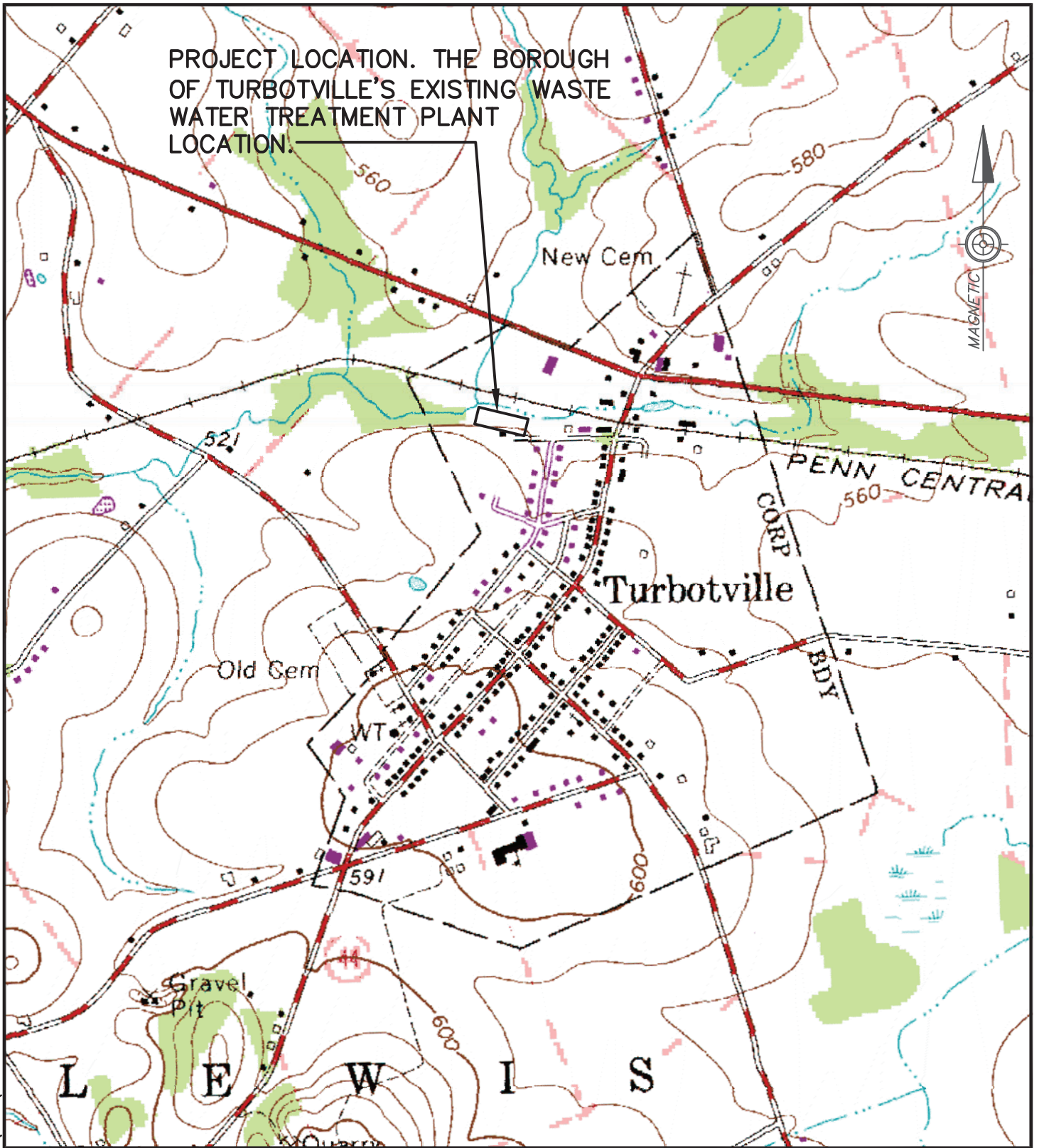

i:\0047\043000\CAD\SUP\LOC\LOC MAP1



2007 Cato Avenue
 State College, PA 16801
 (814) 238-8223 www.uni-tec.com

WASTEWATER TREATMENT PLANT

BOROUGH OF TURBOTVILLE
 NORTHUMBERLAND COUNTY
 PENNSYLVANIA
 LOCATION MAP
 JANUARY 2017

MILTON QUAD

SCALE

1"=1000'

PROJECT NO.

0047043101

SHEET NO.

1



DEMOLITION SITE PLAN
 SCALE: 1"=30'

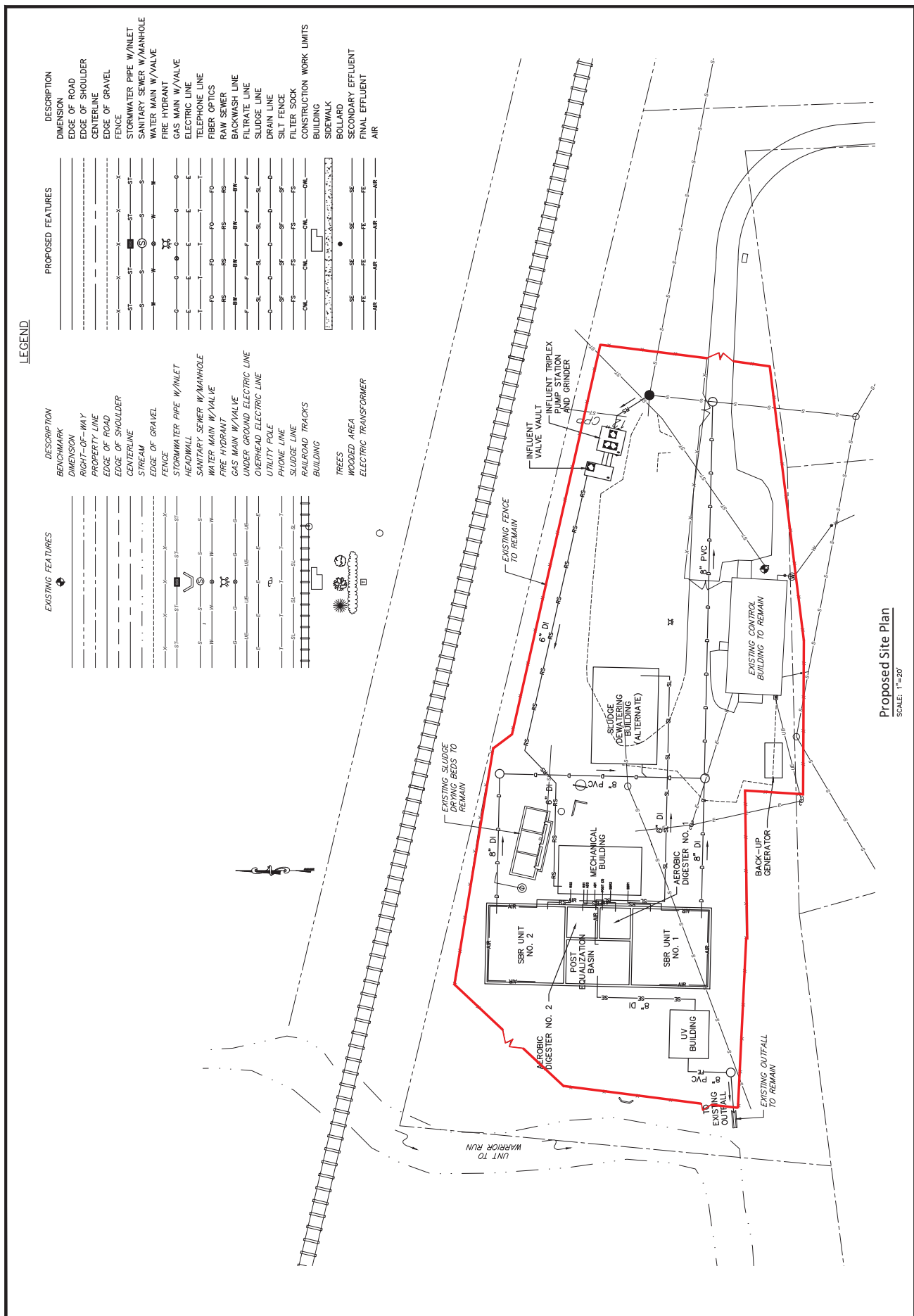

LEGEND

EXISTING FEATURES	DESCRIPTION
--- (dashed line)	BENCHMARK
--- (dotted line)	DIMENSION
--- (long dashed line)	RIGHT-OF-WAY
--- (short dashed line)	PROPERTY LINE
--- (dash-dot line)	EDGE OF ROAD
--- (dotted line)	EDGE OF SHOULDER
--- (dotted line)	CENTERLINE
--- (dotted line)	STREAM
--- (dotted line)	EDGE OF GRAVEL
--- (dotted line)	FENCE
--- (dotted line)	STORMWATER PIPE W/INLET
--- (dotted line)	HEADWALL
--- (dotted line)	SANITARY SEWER W/MANHOLE
--- (dotted line)	WATER MAIN W/VALVE
--- (dotted line)	FIRE HYDRANT
--- (dotted line)	GAS MAIN W/VALVE
--- (dotted line)	UNDER GROUND ELECTRIC LINE
--- (dotted line)	OVERHEAD ELECTRIC LINE
--- (dotted line)	UTILITY POLE
--- (dotted line)	PHONE LINE
--- (dotted line)	SLUDGE LINE
--- (dotted line)	RAILROAD TRACKS
--- (dotted line)	BUILDING
--- (dotted line)	TREES
--- (dotted line)	WOODED AREA
--- (dotted line)	ELECTRIC TRANSFORMER

PROPOSED FEATURES	DESCRIPTION
--- (dashed line)	DIMENSION
--- (dotted line)	EDGE OF ROAD
--- (dotted line)	EDGE OF SHOULDER
--- (dotted line)	CENTERLINE
--- (dotted line)	EDGE OF GRAVEL
--- (dotted line)	FENCE
--- (dotted line)	STORMWATER PIPE W/INLET
--- (dotted line)	SANITARY SEWER W/MANHOLE
--- (dotted line)	WATER MAIN W/VALVE
--- (dotted line)	FIRE HYDRANT
--- (dotted line)	GAS MAIN W/VALVE
--- (dotted line)	ELECTRIC LINE
--- (dotted line)	TELEPHONE LINE
--- (dotted line)	FIBER OPTICS
--- (dotted line)	RAW SEWER
--- (dotted line)	BACKWASH LINE
--- (dotted line)	FILTRATE LINE
--- (dotted line)	SLUDGE LINE
--- (dotted line)	DRAIN LINE
--- (dotted line)	SILT FENCE
--- (dotted line)	FILTER SOCK
--- (dotted line)	CONSTRUCTION WORK LIMITS
--- (dotted line)	BUILDING
--- (dotted line)	SIDEWALK
--- (dotted line)	BOLLARD
--- (dotted line)	SECONDARY EFFLUENT
--- (dotted line)	FINAL EFFLUENT
--- (dotted line)	AIR

Proposed Site Plan
 SCALE: 1"=20'