



DIAMONDBACK

RECEIVED

2019 OCT 21 AM 9:47

PA PUC  
SECRETARY'S BUREAU

October 18, 2019

Rosemary Chiavetta, Secretary  
Pennsylvania Public Utility Commission  
PO Box 3265  
Harrisburg, PA 17105-3265

In re: **A-2019-3011410**, application of the Commonwealth of Pennsylvania, Department of Transportation, for approval to alter twelve (12) public at-grade crossings by the installation of new active traffic control devices and three high-type concrete crossing surfaces where various local roadways cross the twelve (12) tracks of SEDA-COG Joint Rail Authority, operated on by Lycoming Valley Railroad in various municipalities in Lycoming County; **all in accordance with the Federal Grade Crossing Program**; and the allocation of costs incident thereto.

<u>Highway</u>	<u>DOT No.</u>	<u>Municipality</u>
1. SR 147 (King St)	264 183A	Northumberland
2. Orange Street	264 182T	Northumberland
3. Railroad Street	264 155W	Danville
4. Wall Street	264 153H	Danville
5. Central Road	265 992N	Bloomsburg
6. Industrial Park Dr.	908 921W	Bloomsburg
7. S. Eaton Street	266 013M	Berwick
8. SR 54	591 840N	Locust Gap

Dear Rosemary Chiavetta:

A copy of the circuit plans for has been served upon the parties in the Certificate of Service.

Diamondback Signal is sending this on behalf of the North Shore Railroad.

Sincerely,

Kevin Lamb  
Vice President Engineering

Enclosures

SOUTH

NORTH

RECEIVED  
2019 OCT 21 AM 9:49  
PA PUC  
SECRETARY'S BUREAU



START 440'  
30 SECS. @ 10 MPH

START 440'  
30 SECS. @ 10 MPH

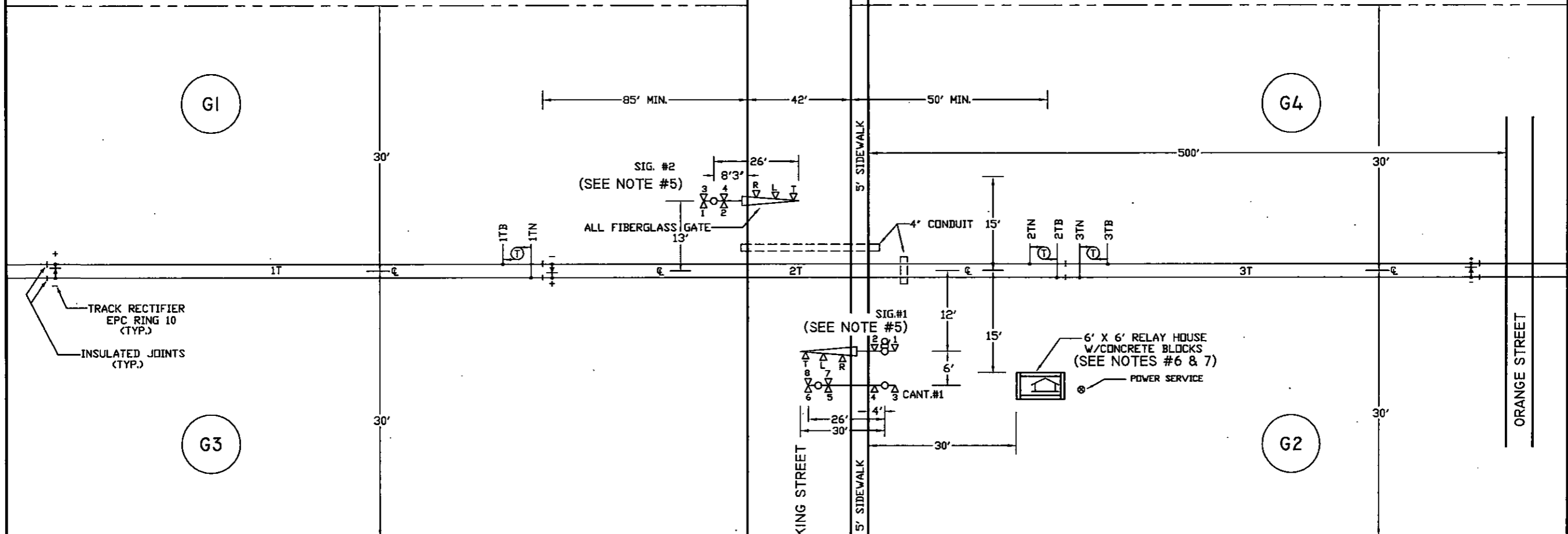

**NOTES:**

1. MATERIAL & INSTALLATION TO BE IN ACCORDANCE WITH MUTCD, STATE AND RAILROAD STANDARDS.
2. ALL DIMENSIONS ARE APPROXIMATE AND MAY VARY DUE TO ACTUAL FIELD CONDITIONS.
3. EQUIPMENT TO BE PLACED TO ALLOW FOR FUTURE GATES.
4. (T) DENOTES TWIST PAIR.
5. REUSE EXISTING CANTILEVER FOUNDATIONS AND INSTALL AN ADAPTER PLATE FOR THE GATES.
6. SET THE HOUSE 2' ABOVE TOP OF RAIL DUE TO FLOODING IN AREA.
7. SET CONCRETE BLOCKS AROUND RELAY HOUSE AND CONCRETE STEPS DUE TO FLOODING IN AREA.

**CABLE RUN TABULATION**

- HOUSE TO SIGNAL #1
- HOUSE TO SIGNAL #2
- HOUSE TO POWER SERVICE
- HOUSE TO 1TN & 1TB
- HOUSE TO 2TN & 2TB
- HOUSE TO 3TN & 3TB
- 5/C #6 UG CABLE
- 7/C #14 UG CABLE
- 5/C #6 UG CABLE
- 7/C #14 UG CABLE
- 3/C #9 UG CABLE
- #6 TW. PAIR UG CABLE
- #6 TW. PAIR UG CABLE
- #6 TW. PAIR UG CABLE

<b>DIAMONDBACK SIGNAL</b>  (410) 795-9601 5965 EXCHANGE DRIVE SUITE 'D' SYKESVILLE, MD 21784	NORTH SHORE RAILROAD RAILROAD CROSSING WARNING DEVICES		
	SCALE: NONE	APPROVED BY:	DRAWN BY: DBS
	DATE: 9/20/2019		REVISED:
	KING STREET - DOT # 264 183A - M.P. 213.18 NORTHUMBERLAND, NORTHUMBERLAND COUNTY, PA		
TRACK & CABLE PLAN		DRAWING NUMBER 23.18	

PA PUC  
SECRETARY'S BUREAU

2019 OCT 21 AM 9:47

RECEIVED

RECEIVED  
 2019 OCT 21 AM 9:48  
 PA PUC  
 SECRETARY'S BUREAU

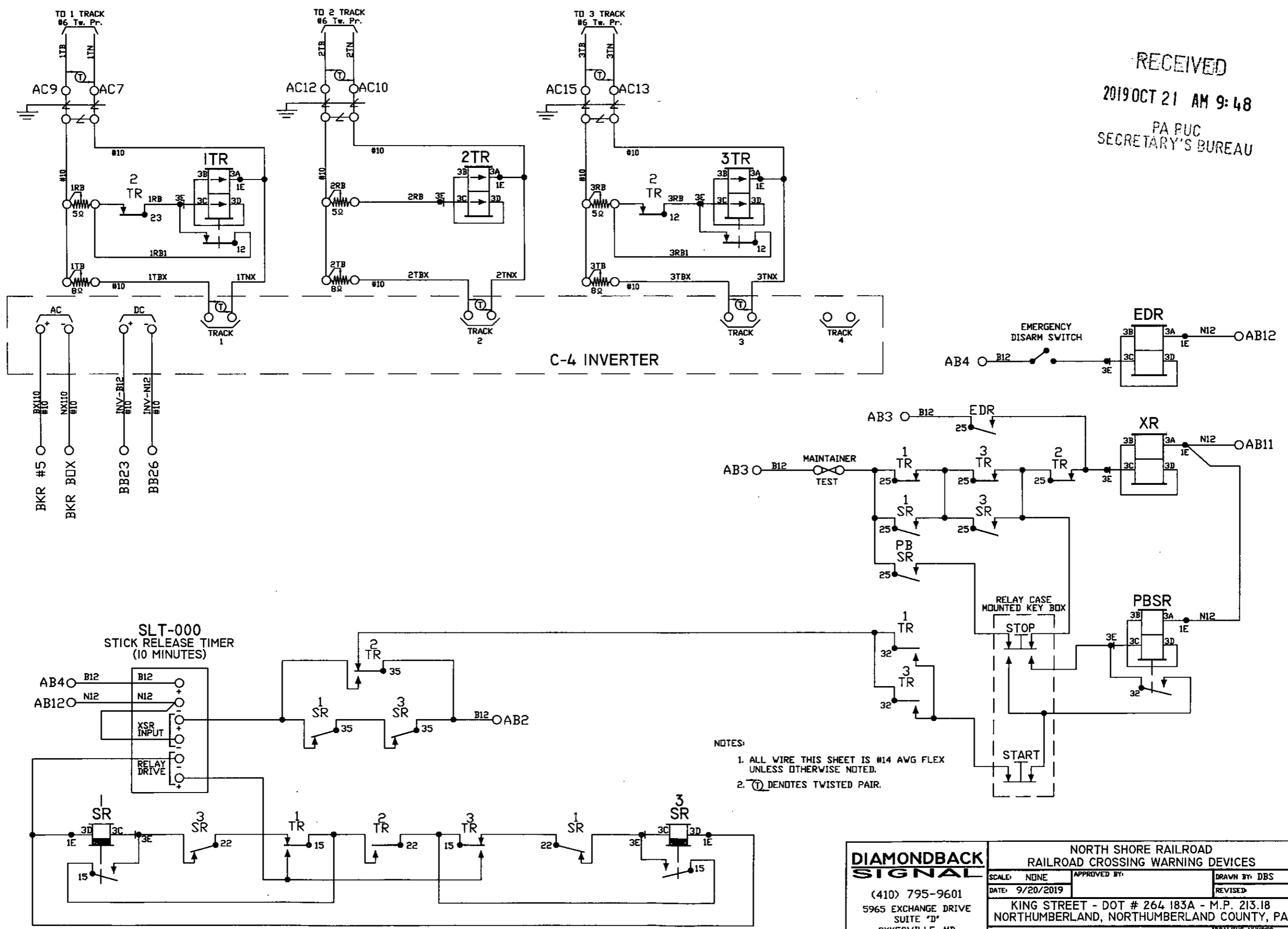

- NOTES:
1. ALL WIRE THIS SHEET IS #14 AWG FLEX UNLESS OTHERWISE NOTED.
  2. (T) DENOTES TWISTED PAIR.

**DIAMONDBACK SIGNAL**  
 (410) 795-9601  
 5965 EXCHANGE DRIVE  
 SUITE "D"  
 SYKESVILLE, MD  
 21784

NORTH SHORE RAILROAD RAILROAD CROSSING WARNING DEVICES		
SCALE: NONE	APPROVED BY:	DRAWN BY: DBS
DATE: 9/20/2019		REVISED:
KING STREET - DOT # 264 183A - M.P. 213.18 NORTHUMBERLAND, NORTHUMBERLAND COUNTY, PA		
CIRCUIT PLAN "A"		DRAWING NUMBER 23.18

RECEIVED  
 2019 OCT 21 AM 9:48  
 PA PUC  
 SECRETARY'S BUREAU

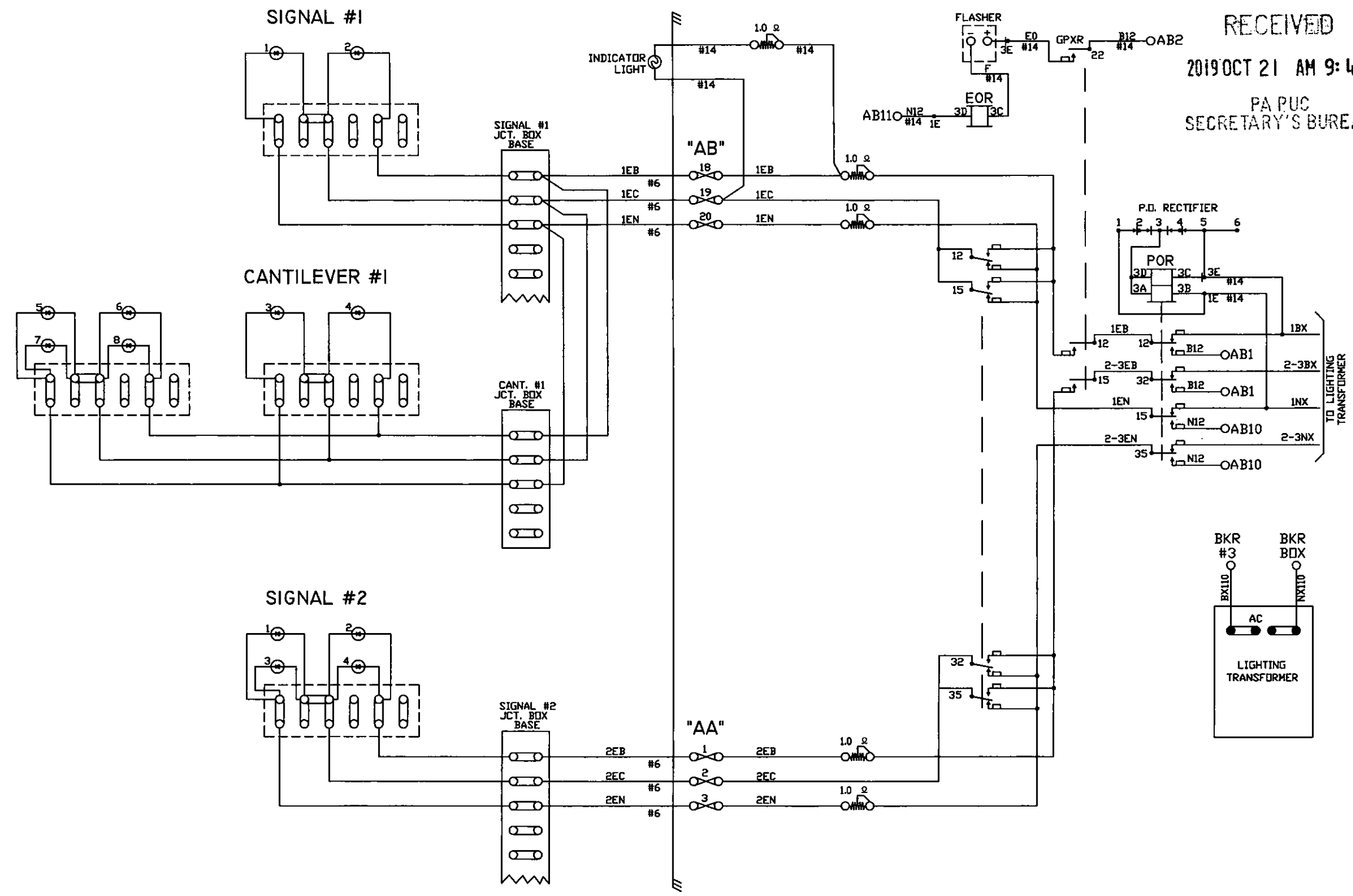

NOTE:  
 ALL WIRE THIS SHEET IS #10 AWG. FLEX  
 UNLESS OTHERWISE NOTED.

<b>DIAMONDBACK SIGNAL</b> (410) 795-9601 5965 EXCHANGE DRIVE SUITE "D" SYKESVILLE, MD 21784	NORTH SHORE RAILROAD RAILROAD CROSSING WARNING DEVICES	
	SCALE: NONE DATE: 9/20/2019	APPROVED BY: DRAWN BY: DBS REVISED:
	KING STREET - DOT # 264 183A - M.P. 213.18 NORTHUMBERLAND, NORTHUMBERLAND COUNTY, PA	
	CIRCUIT PLAN "B"	DRAWING NUMBER 23.18

RECEIVED

2019 OCT 21 AM 9:48

PA PUC SECRETARY'S BUREAU

CONTACT	CLOSED	FUNCTION	TENSION
1B	75-90°	POWER DOWN	18-22 OZ.
1F	0-70°	SNUB DOWN	18-22 OZ.
2	0-86°	POWER UP	18-28 OZ.
3	0-10°	GATE DOWN	16-24 OZ.
4	82-90°	GATE CLEAR	16-24 OZ.
5	10-90°	BELL	16-24 OZ.
6	SPARE	SPARE	16-24 OZ.
7	0-10°	SNUB	16-24 OZ.

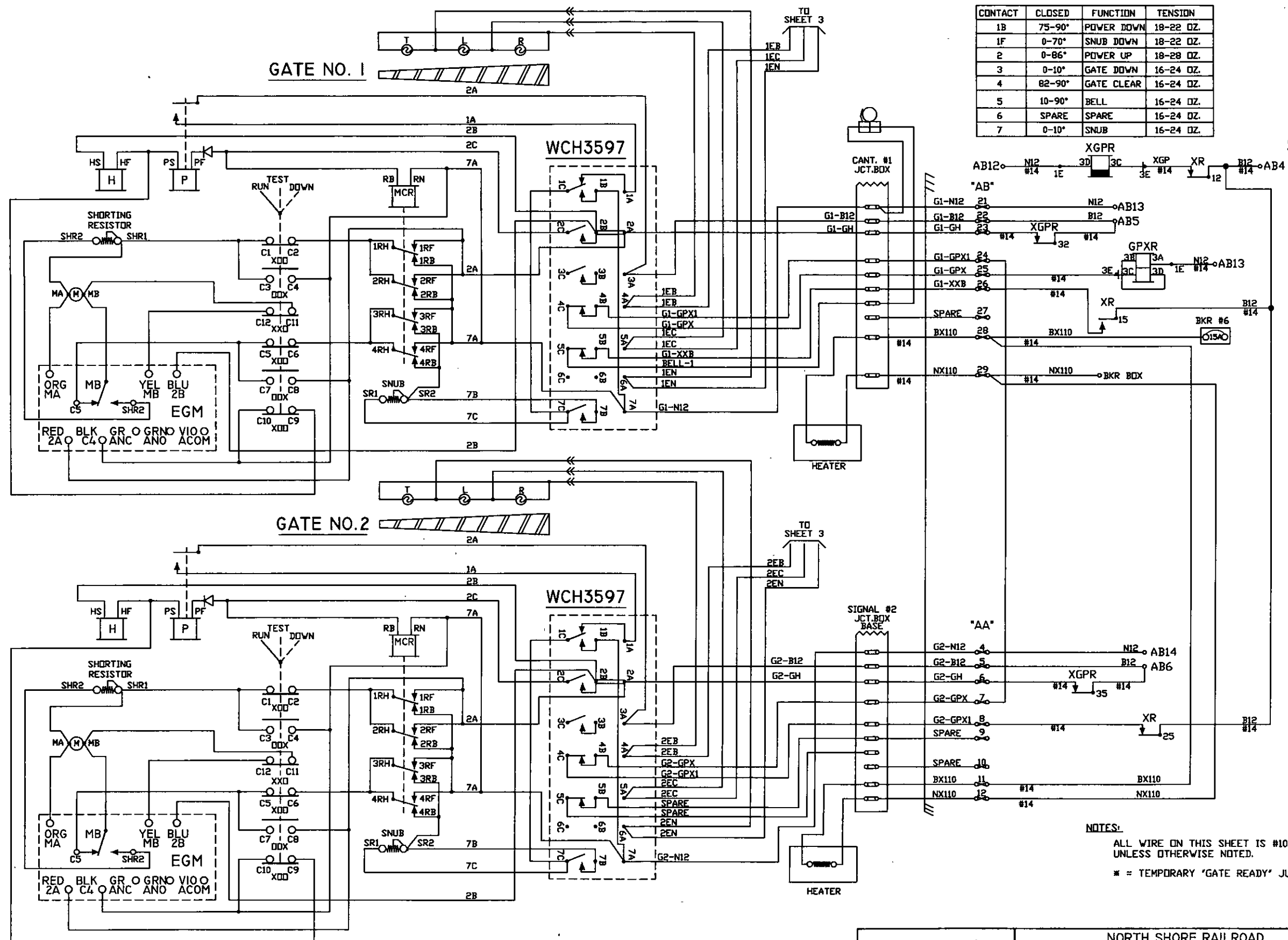

NOTES:  
 ALL WIRE ON THIS SHEET IS #10AWG UNLESS OTHERWISE NOTED.  
 \* = TEMPORARY 'GATE READY' JUMPER.

**DIAMONDBACK SIGNAL**  
 (410) 795-9601  
 5965 EXCHANGE DRIVE  
 SUITE 'D'  
 SYKESVILLE, MD 21784

NORTH SHORE RAILROAD RAILROAD CROSSING WARNING DEVICES		
SCALE: NONE	APPROVED BY:	DRAWN BY: DBS
DATE: 9/20/2019		REVISED:
KING STREET - DOT # 264 183A - M.P. 213.18 NORTHUMBERLAND, NORTHUMBERLAND COUNTY, PA		
CIRCUIT PLAN 'C'		DRAWING NUMBER 23.18

RECEIVED

2019 OCT 21 AM 9:48

PA PUC SECRETARY'S BUREAU

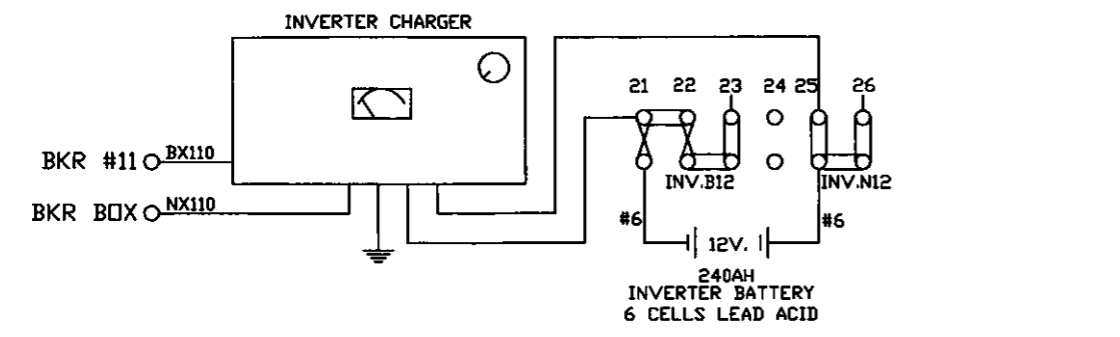

"BB"

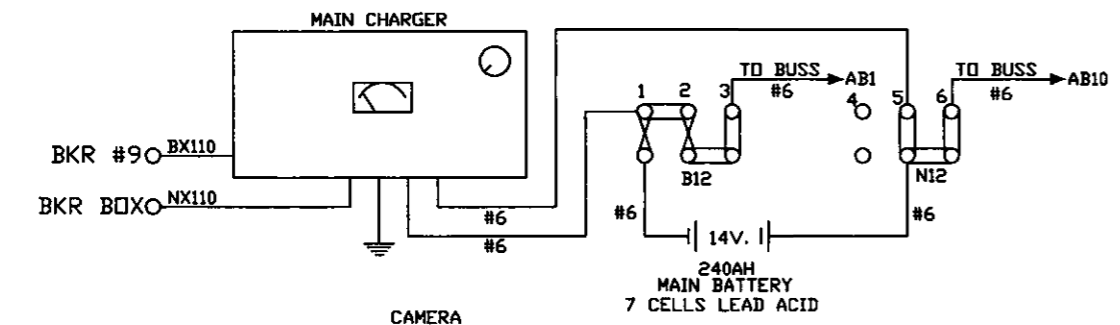
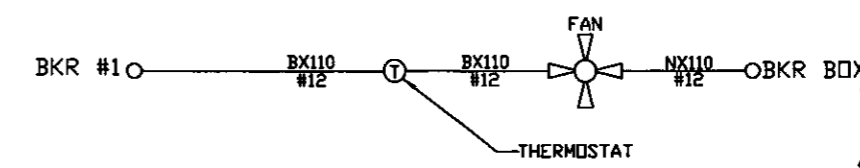

"BB"

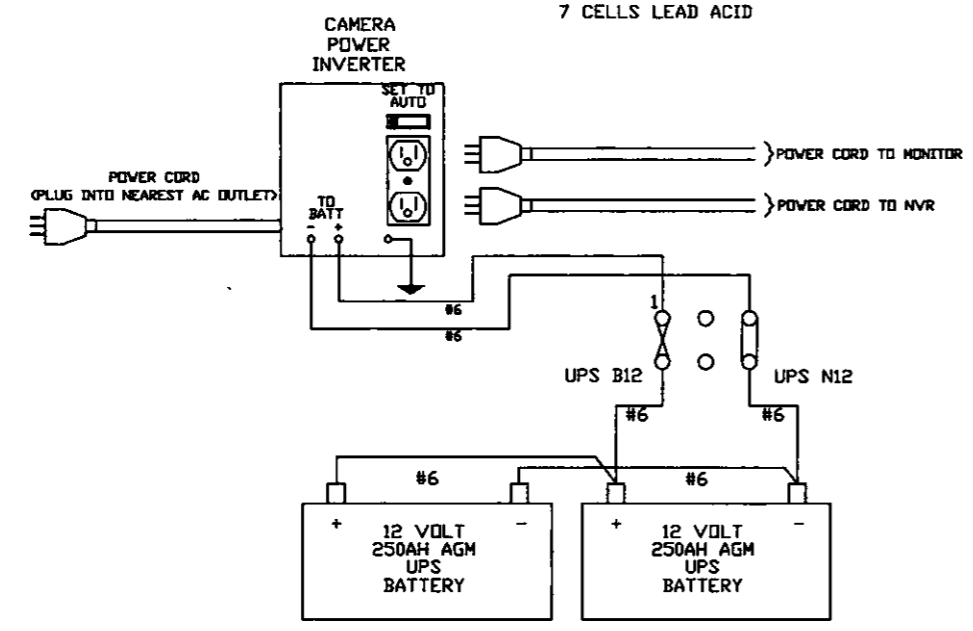
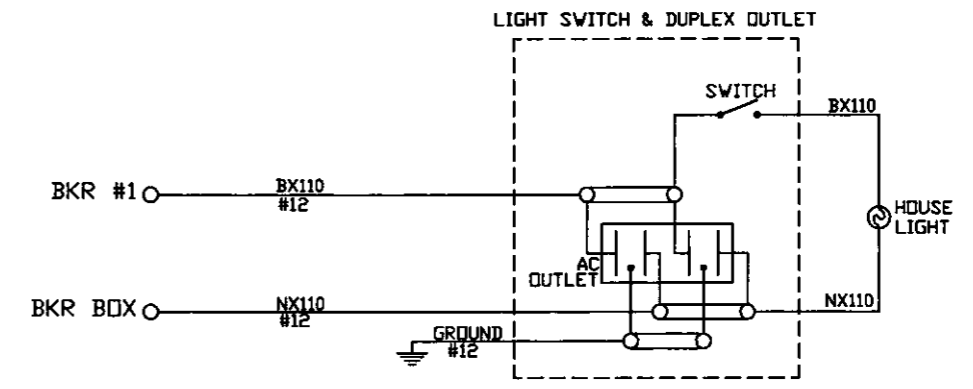

"CB"

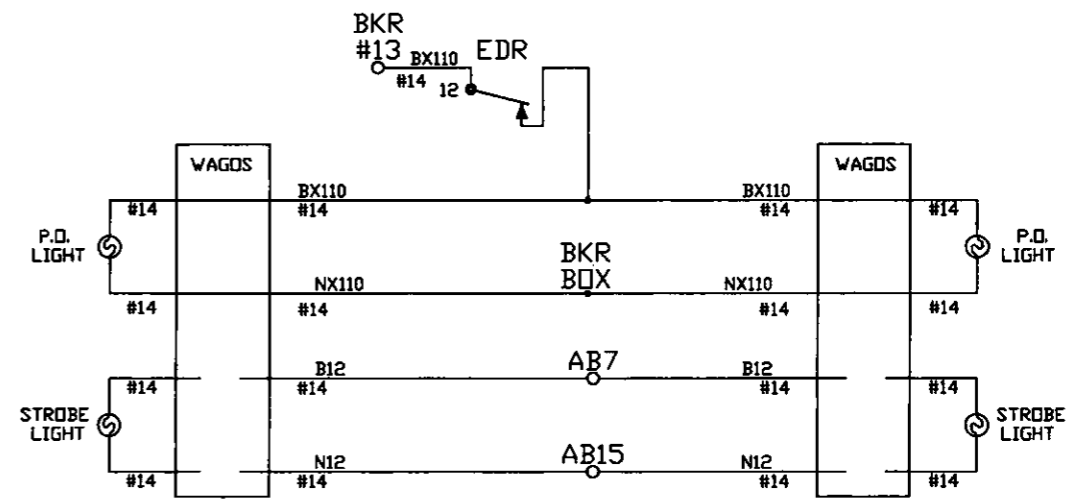

NOTE:  
ALL WIRE THIS SHEET IS #10 AWG FLEX  
UNLESS OTHERWISE NOTED.

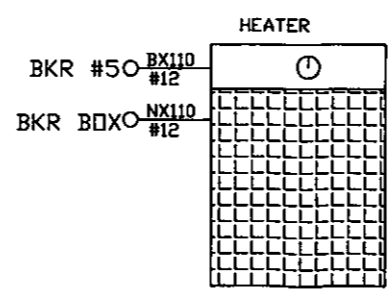
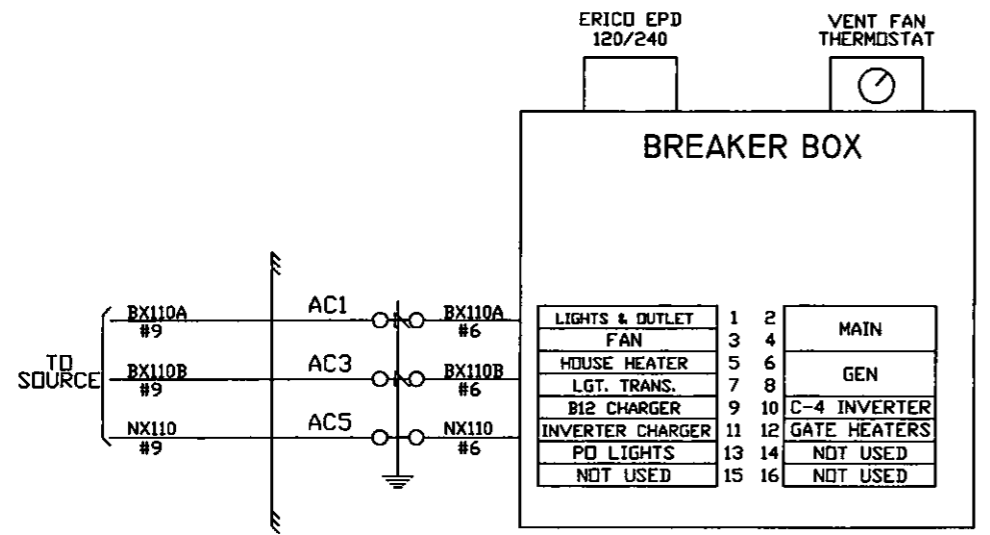

**DIAMONDBACK SIGNAL**  
(410) 795-9601  
5965 EXCHANGE DRIVE  
SUITE "D"  
SYKESVILLE, MD  
21784

NORTH SHORE RAILROAD  
RAILROAD CROSSING WARNING DEVICES  
SCALE: NONE  
DATE: 9/20/2019  
APPROVED BY:  
DRAWN BY: DBS  
REVISED:  
KING STREET - DOT # 264 183A - M.P. 213.18  
NORTHUMBERLAND, NORTHUMBERLAND COUNTY, PA  
CIRCUIT PLAN "D"  
DRAWING NUMBER  
23.18



I hereby certify that I have this day served a true copy of the foregoing document upon the participants, listed below, in accordance with the requirements of § 5.14, by first class mail, postage prepaid:

Mr. Mark Chappell, P.E., Chief  
PA Department of Transportation  
Bureau of Design  
Utilities and Right-of-Way Section  
P.O. Box 3362  
Harrisburg, Pennsylvania 17105-3362

Ms. Gina D'Alfonso, Assistant Counsel  
PA Department of Transportation  
Office of Chief Counsel  
P.O. Box 3265  
Harrisburg, Pennsylvania 17105-3265

Mr. Steve Betts  
PA Department of Transportation  
Engineering District 3-0 Utilities  
715 Jordan Avenue  
Montoursville, PA 17754

Mr. Ron Hull, PE  
Pennsylvania Public Utility Commission  
PO Box 3265  
Harrisburg, PA 17105-3265

Mr. George Fury, Property Manager  
SEDA COG Joint Rail Authority  
201 Furnace Road  
Lewisburg, PA 17837

Mr. Tom Avery, Director of Operations  
North Shore Railroad Company  
356 Priestly Avenue  
Northumberland, PA 17857

Maryrose B. McCarthy, Chief Clerk  
Northumberland County Commissioners  
399 South Fifth Street  
Sunbury, PA 17801

Holly Brandon, Chief Clerk  
Montour County Commissioners  
29 Mill Street  
Danville, PA 17821

David Withey, Chief Clerk  
Columbia County Commissioners  
11 West Main Street  
Bloomsburg, PA 17815

Shannon Berkey, Borough Manager  
Danville Borough  
239 Mill Street  
Danville, PA 17821

Casandra Mowery, Treasurer  
Berwick Borough  
344 Market Street  
Berwick, PA 18603

Janice Bowman, Secretary  
Northumberland Borough  
175 Orange Street  
Northumberland, PA 17857

Lauren Martz, Town Administrator  
Town of Bloomsburg  
301 East Second Street  
Bloomsburg, PA 17815

Brittany Stasik, Secretary  
Scott Township Supervisors  
350 Tenny Street  
Bloomsburg, PA 17815

Dale Sneiderman, Secretary  
South Centre Township Supervisors  
6260 4<sup>th</sup> Street  
Bloomsburg, PA 17815

Lisa Fiamoncini, Clerk  
Mount Carmel Township Supervisors  
300 Laurel Street  
Mount Carmel, PA 17851

Donald Phillips, Engineer  
Service Electric Cable TV, Inc.  
3662 Point Township Drive  
Northumberland, PA 17857

Andrew Minnich, Staff Engineer  
UGI Penn Natural Gas, Inc.  
1 PEI Center  
Wilkes Barre, PA 18711

Robert Jaworski, Engineer  
Verizon of Pennsylvania  
11 Ridge Road  
Bloomsburg, PA 17815

Gloria Bobersky, Manager  
Berwick Area Joint Sewer Authority  
1108 Freas Avenue  
Berwick, PA 18603

Jeremy Dietrick, Manager  
Northumberland Sewer Authority  
100 Water Street  
Northumberland, PA 17857

Randy Wilkin, Engineer  
Pennsylvania American Water Co.  
306 West Front Street  
Berwick, PA 18603

Charlotte Krupa, PennDOT Liasion  
PPL Electric Utilities Corporation  
Two North Ninth Street  
GENN 3  
Allentown, PA 18101

Tate Hunsinger, Engineer  
Suez Water PA  
90 Irondale Road  
Bloomsburg, PA 17815

John Klinger, Engineer  
AQUA Pennsylvania Incorporated  
204 East Sunbury Street  
Shamokin, PA 17872

We respectfully request the approval of these plans. Should you have any questions or concerns, please contact me.

Dated this 18<sup>th</sup> day of October 2019.



Kevin Lamb  
(410) 795-9601

PRESS FIRMLY TO SEAL

PRESS FIRMLY TO SEAL

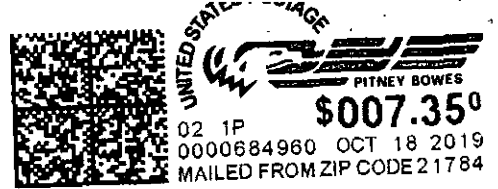

# PRIORITY<sup>®</sup> MAIL

- Date of delivery specified\*
- USPS TRACKING™ included to many major international destinations.
- Limited international insurance.
- Pick up available.\*
- Order supplies online.\*
- When used internationally, a customs declaration label may be required.

\* Domestic only



PS00001000014

EP14F Oct 2018  
OD: 12 1/2 x 9 1/2



**DIAMONDBACK SIGNAL**  
5965 Exchange Drive  
Suite D  
Sykesville, MD 21784

Rosemary Chiavetta, Secretary  
Pennsylvania Public Utility Commission  
PO Box 3265  
Harrisburg, PA 17105-3265

To see  
Package Pickup,  
scan the QR code.



USPS.COM/PICKUP