



**Emily M. Farah**  
Counsel, Regulatory

411 Seventh Avenue  
Mail drop 15-7  
Pittsburgh, PA 15219

Tel: 412-393-6431  
efarah@duqlight.com

August 24, 2021

**VIA ELECTRONIC FILING**

Rosemary Chiavetta, Secretary  
Pennsylvania Public Utility Commission  
Commonwealth Keystone Building, 2<sup>nd</sup> Floor  
400 North Street  
Harrisburg, PA 17120

**Re: Municipal Contract –Right of Way Agreement between Duquesne Light Company  
and the Housing Authority of The County of Beaver  
Docket No. U-2021-\_\_\_\_\_**

Dear Secretary Chiavetta:

Enclosed for review and approval in accordance with 66 Pa.C.S. § 507 and 52 Pa. Code § 3.101, is a Right of Way Agreement dated August 5, 2021 between Duquesne Light Company (“Duquesne Light” or the “Company”) and the Housing Authority of The County of Beaver (“Housing Authority”). The Housing Authority granted to Duquesne Light a Right of Way on its property situated on Deer Lane in Rochester Borough, Beaver County, which provides the right to install, use, own, operate, maintain, repair, renew and remove an electrical line.

Should you have any questions regarding the enclosed right of way, please contact Dan Antosik at 412-393-8628.

Respectfully Submitted,

A handwritten signature in blue ink, appearing to read "Emily M. Farah".

Emily M. Farah  
Attorney ID#322559

Enclosure

ANCCORP. 2/01  
848897

DUQUESNE LIGHT CO. COPY

### RIGHT OF WAY AGREEMENT

The undersigned Grantor, **THE HOUSING AUTHORITY OF THE COUNTY OF BEAVER**, for good and valuable consideration, the receipt of which is hereby acknowledged **does** hereby grant unto Duquesne Light Company, its successors and assigns, for providing, transmitting and/or distributing electric and/or communications services current for any and all purposes, the right, privilege and authority to install, use, own, operate, maintain, repair, renew and finally remove **one (1)** anchor attached to pole #3860, together with the guy wires and other apparatus thereto belonging, upon, over, under, along and across Grantors land, fronting on **Deer Lane**, situate in **Rochester Borough, Beaver County**, Pennsylvania, and shown on Duquesne Light Company Drawing No. **848897**, a copy of which has been attached to and made part hereof. Duquesne Light Company shall also have the following rights: to trim or remove any trees or shrubbery which, at any time or times, may interfere or threaten to interfere with the erection, installation, use, operation, maintenance, repair, renewal or removal of the electric line; to enter upon the land at any time for such purposes; to permit others to attach guys and related apparatus; and to sell, assign, lease or otherwise transfer any or all rights hereunder.

Utility shall file a copy of this Agreement with the Pennsylvania Public Utility Commission as required by Title 66, Section 507 of the Public Utility Code, and this Agreement shall become effective in accordance therewith.

Intending to be legally bound the Grantor **has** executed this agreement this 5<sup>th</sup> day of August, 2021.

GRANTOR:

**HOUSING AUTHORITY OF BEAVER  
COUNTY**

ATTEST/WITNESS:

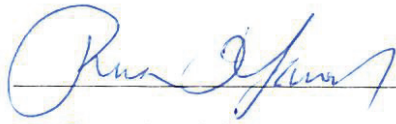

By:   
Name: BRIAN L. YAWORSKY  
Title: EXECUTIVE DIRECTOR

THIRD PARTY TRANSFERS  
 NJUNS TK #4148398

1. COMCAST
2. VERIZON

MAP: C3-1  
 CKT: D23780-1 (VALLEY)  
 D23783-1 (VALLEY)  
 22813 (VALLEY-WESTINGHOUSE)



①

DL#3860  
 VZ#159-4

- 18M DOWN GUY  
 - SHLX (6' LD)

PARCEL: 460010117000  
 OWNER: HOUSING AUTHORITY  
 OF BEAVER COUNTY

ALL WORK SHALL CONFORM THE  
 REQUIREMENTS OF DUQUESNE LIGHT  
 COMPANY (DLC) CONSTRUCTION  
 STANDARDS AND THE NATIONAL  
 ELECTRIC SAFETY CODE (NEC), 2017  
 EDITION

CONSTRUCTION STANDARDS SHOWN ON  
 THE DRAWINGS ARE FOR REFERENCE  
 ONLY

CONTRACTOR SHALL VERIFY ALL  
 DIMENSION AND CONDITIONS AT THE JOB  
 SITE PRIOR TO BEGINNING WORK AND  
 SHALL REPORT ANY DISCREPANCIES TO  
 THE ENGINEER

THIS DRAWING ADDRESSES OVERHEAD  
 CONSTRUCTION CLEARANCES AND POLE  
 LOADING ONLY. ELECTRICAL DESIGN,  
 INCLUDING BUT NOT LIMITED TO  
 CONDUCTOR SIZING, TRANSFORMER  
 LOADING, AND OVERALL SUITABILITY AND  
 PERFORMANCE OF THE ELECTRICAL  
 SYSTEM IS THE RESPONSIBILITY OF THE  
 OWNER.

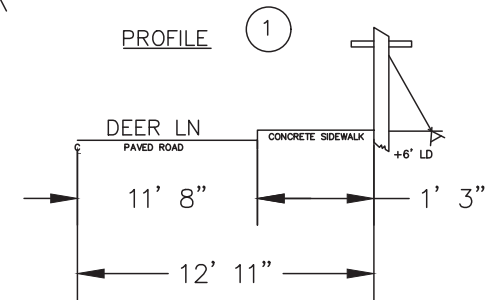
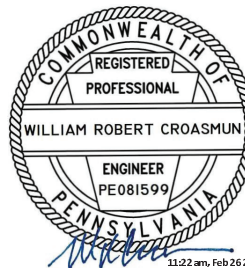

20210571293



**DUQUESNE LIGHT CO.**

DISTRIBUTION ENGINEERING

THIRD PARTY ATTACHMENT REQUEST  
 138 DEER LANE, ROCHESTER, PA 15074  
 ROCHESTER BOROUGH

AS-ISSUED_CHK'D	AS-MARKED_CHK'D	SCALE	DATE COMPL'D	DRAWN BY	ENGR_CHK'D	DATE	DLC MAINTENANCE ON DL#3860 FOR THIRD PARTY ATTACHER		
DATE		NTS	2/26/2021	DAVEY R. GILMOUR Resource Group	FINAL APP.	DATE	FPN	PR. NO.	MAXIMO WO. NO.
							20-0169	4161	848897

REV.0