

**BEFORE THE
PENNSYLVANIA PUBLIC UTILITY
COMMISSION**

Application of Peoples Natural Gas Company :
LLC for approval of the alteration of railroad :
crossing 145570P by the installation of gas : Docket No. A-2022-_____
pipeline where Thomas Eighty Four Rd., S.R. :
1055 crosses at grade the tracks of the :
Allegheny Valley Railroad Company, located in :
the Township of North Strabane in :
Washington County, Pennsylvania :

**APPLICATION OF PEOPLES NATURAL GAS COMPANY LLC FOR
APPROVAL OF ALTERATION OF RAILROAD CROSSING**

To Pennsylvania Public Utility Commission:

1. The name and address of applicant is:

Peoples Natural Gas Company LLC
375 North Shore Drive, Suite 600
Pittsburgh, PA 15212

2. The name and address of applicant's attorney:

Meagan Moore
Peoples Natural Gas Company LLC
375 North Shore Drive, Suite 400
Pittsburgh, PA 15212

3. Peoples Natural Gas Company LLC ("Peoples") is a public utility certificated by the Pennsylvania Public Utility Commission ("Commission") that provides natural gas service to approximately 635,000 customers in all or a portion of the following Pennsylvania counties: Allegheny, Armstrong, Beaver, Blair, Butler, Cambria, Clarion, Fayette, Greene, Indiana, Lawrence, Mercer, Somerset, Venango, Washington, and Westmoreland. Peoples is replacing its Goodwin Tombaugh distribution pipeline system. As part of that system replacement, Peoples proposes to install a four inch MDPE natural gas pipeline inserted into an eight inch steel casing pipeline where Thomas Eighty Four Rd, S.R. 1055 crosses at grade the tracks of Allegheny Valley Railroad, DOT No. 145570P.

4. Attached as Exhibit 1 are drawings showing the location of the proposed four inch MDPE line inserted into an eight inch steel casing line, a section view of the crossing and details of the casing pipe that will be installed.
5. Copies of this application will be served to all interested parties. These include:
 - Allegheny Valley Railroad (Carload Express)
 - Pennsylvania Department of Transportation
 - Washington County Planning Commission
 - North Strabane Township
 - PA American Water
 - First Energy
 - Comcast Cable
6. The estimated cost of installing the facilities is \$25,000. The gas facilities will be installed, maintained and inspected by Peoples who is the sole funding source for the replacement project.
7. The alteration is necessary to replace aging bare steel pipeline.

Wherefore, Peoples Natural Gas Company LLC respectfully requests that the Commission approve this application.

PEOPLES NATURAL GAS COMPANY LLC



Meagan Moore
Counsel for Peoples Natural Gas Company LLC

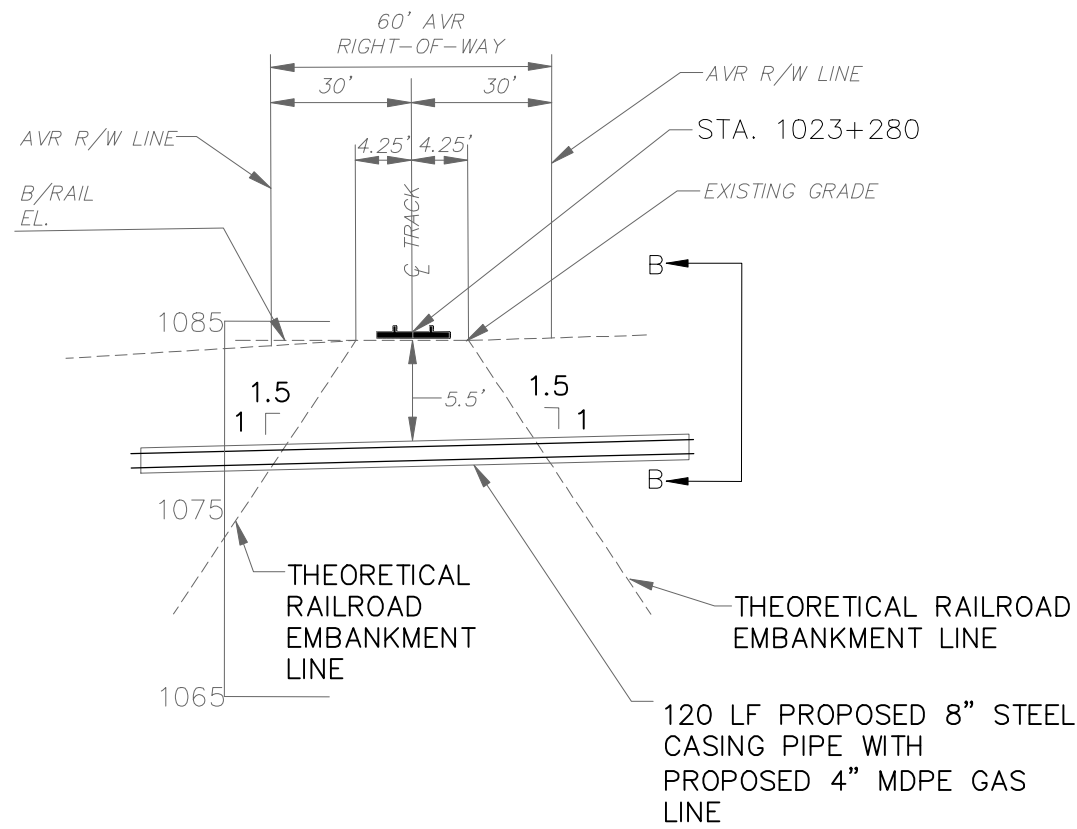

PROFILE VIEW A-A

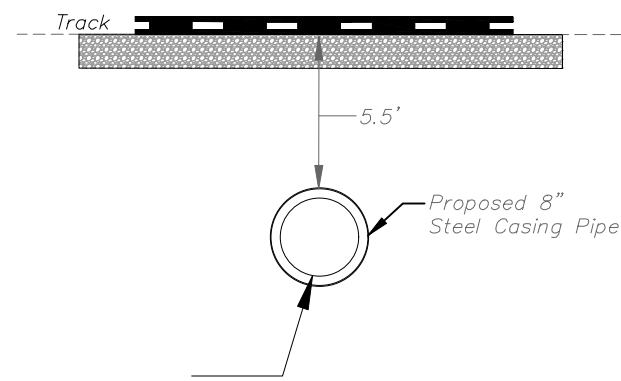

PROPOSED 4" MDPE PIPE INSERTED IN 8" POWER CRETE STEEL GAS LINE

CROSS SECTION VIEW B-B

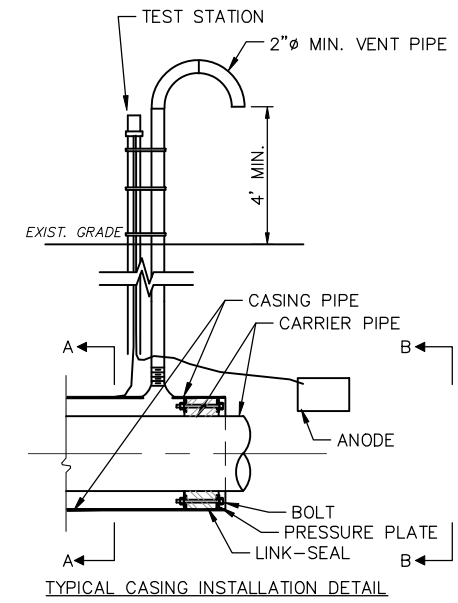

TYPICAL CASING INSTALLATION DETAIL

NOTE:

1. LINK SEAL TO BE LOCATED AT BOTH ENDS OF THE CASING PIPE.
2. VENT PIPES SHALL BE LOCATED ON THE BOTH ENDS OF CASING PIPE.
3. VENT PIPES SHALL BE AT LEAST 4 FT. VERTICALLY, FROM AERIAL ELECTRIC WIRES OR GREAT IS REQUIRED BY NATIONAL ELECTRICAL SAFETY CODE (ANSI C2)

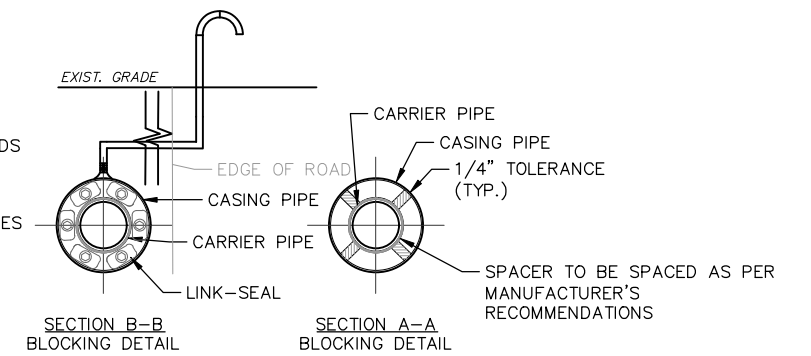

SECTION B-B BLOCKING DETAIL

SECTION A-A BLOCKING DETAIL

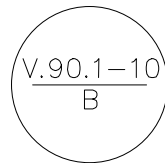

GENERAL NOTES

1. REFER TO BORING INTERIM GUIDELINES AND ENGINEERING SPECIFICATIONS IN THE APPLICATION PACKAGE FOR ADDITIONAL INFORMATION AND GUIDANCE.
2. LOCATE ALLEGHENY VALLEY RAILROAD'S SIGNAL FACILITIES AND/OR WARNING DEVICES AT PROPOSED FACILITY CROSSING LOCATION, I.E. CANTILEVERS, FLASHERS, GATES AND SHOW CLEARANCES.
3. CASING PIPE MUST BE SEALED TO PREVENT ENTRANCE OF FOREIGN MATERIALS
4. IF APPLICABLE, HDPE DR 11 OR BETTER MUST BE USED.
5. YOUR DRAWING MUST SHOW ALL SETS OF TRACTS PRESENT AT THE PROPOSED UTILITY CROSSING LOCATION.
6. CARLOAD EXPRESS BORE PLAN TEMPLATE AND FRACTION MITIGATION PLAN TO BE SUBMITTED TO CARLOAD EXPRESS FOR REVIEW AND APPROVAL PRIOR CONSTRUCTION.

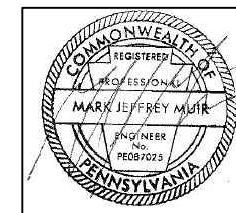

PRELIMINARY

TEST FOR (SIZE)* STL/PLA	XX/XX/XXXX
DESIGN PRESSURE	60 PSIG
MAOP	60 PSIG
TEST PRESSURE MIN.	HRS @ PSIG
TEST PRESSURE MAX.	PSIG
ACTUAL TEST PRES.	HRS @ PSIG
OPERATING PRESSURE	PSIG
MIN.	PSIG
MAX.	PSIG
CLASS LOCATION	3
DESIGN FACTOR	FACTOR
STEEL PIPE PO #	PO#
PRESSURE TEST	YES / NO
TEST MEDIUM	AIR

REVISION	DRAWING HISTORY	BY & DATE
0	DRAWING DESCRIPTION	XXX: XX/XX/XXXX
A,B,C	DESIGN	XXX: XX/XX/XXXX
1,2,3	AS-BUILT DESIGN	XXX: XX/XX/XXXX

PEOPLES MAKING YOUR LIFE BETTER
 WORK ORDER NUMBER:
 23GTREN-PHASE 4 AREA 4A
 THOMAS EIGHTY FOUR RD (S.R.1055), EIGHTY FOUR, PA
 NORTH STRABANE TWP, WASHINGTON, PA
 DESIGNED BY: EADS DATE: XX/XX/XXXX SCALE: AS NOTED
 DRAWN BY: R. HEGEDUS CHK BY: D. WALKER SHEET: 02 OF 02
 DATE DRAWN: 10/03/2022 DATE APPR: XX/XX/XXXX CO WITH: YES/NO/NA

VERIFICATION

I, Kenneth Cole, hereby state that the facts above set forth are true and correct to the best of my knowledge, information and belief and that I expect to be able to prove the same at a hearing held in this matter. I understand that the statements herein are made subject to the penalties of 18 Pa. C.S. § 4904 (relating to unsworn falsification to authorities).

Date: 11/15/2022

K. Cole
(Signature)

CERTIFICATE OF SERVICE

I hereby certify that I have this day served a true copy of the foregoing document upon the participants, listed below, in accordance with the requirements of § 1.54 (*relating to service by participant*).

Allegheny Valley Railroad (Carload Express)
519 Cedar Way, Bldg 1, Suite 100, Oakmont, PA 15139

Pennsylvania Department of Transportation (ROW & Utility Division), Bureau of Design – PennDOT, P.O. Box 3362, Harrisburg, PA 17105-3362

Pennsylvania Department of Transportation – Office of Chief Counsel
PennDOT, P.O. Box 8212, Harrisburg, PA 14105-8212

Pennsylvania Department of Transportation – District 12
825 N. Gallatin Ave Ext, Uniontown, PA 15401-2105

Washington County Planning Commission
95 West Beau Street, Washington, PA 15301

North Strabane Township
1929 Route 519, Canonsburg, PA 15317

Pennsylvania American Water
500 Noblestown Road, Carnegie, PA 15106

First Energy
365 Washington Road, Washington, PA 15301

Comcast Cable
15 Summit Park Drive, Pittsburgh, PA 15275

Dated this 15th day of November, 2022



(Signature)