



COMMONWEALTH OF PENNSYLVANIA
PENNSYLVANIA PUBLIC UTILITY COMMISSION
COMMONWEALTH KEYSTONE BUILDING
400 NORTH STREET, HARRISBURG, PA 17120

BUREAU OF
INVESTIGATION
&
ENFORCEMENT

December 19, 2022

Via Electronic Filing

Rosemary Chiavetta, Secretary
Pennsylvania Public Utility Commission
Commonwealth Keystone Building
400 North Street
Harrisburg, PA 17120

Re: Application of the Department of Transportation of the Commonwealth of Pennsylvania for approval to alter the crossings where State Route 3104 crosses, above grade, the tracks of CSX Transportation Inc. (DOT 584 825 U), Norfolk Southern Railway Company (DOT 507 455 K), and the Pittsburgh and Ohio Central Railroad Company (DOT Unknown) in the City of Pittsburgh, Stowe Township and McKees Rocks Borough, Allegheny County.
Docket No. A-2020-3020667

I&E Prehearing Conference Memorandum

Dear Secretary Chiavetta:

Enclosed for electronic filing is the Bureau of Investigation and Enforcement's ("I&E") **Prehearing Conference Memorandum** in the above-referenced matter.

Copies have been served on the parties of record in accordance with the Certificate of Service. If you have any questions, please contact the undersigned.

Sincerely,

Kayla L. Rost
Prosecutor
Bureau of Investigation and Enforcement
PA Attorney ID No. 322768
(717) 787-1888
karost@pa.gov

KLR/ac
Enclosures

cc: Per Certificate of Service
Nicholas Miskanic, Legal Assistant (*via email* - nmiskanic@pa.gov)
Daniel Helfrich, P.E. (*via email* - dhelfrich@pa.gov)

**BEFORE THE
PENNSYLVANIA PUBLIC UTILITY COMMISSION**

Application of the Department of :
Transportation of the Commonwealth of :
Pennsylvania for approval to alter the :
crossings where State Route 3104 :
crosses, above grade, the tracks of CSX :
Transportation Inc. (DOT 584 825 U), : Docket No. A-2020-3020667
Norfolk Southern Railway Company :
(DOT 507 455 K), and the Pittsburgh and :
Ohio Central Railroad Company (DOT :
Unknown) in the City of Pittsburgh, :
Stowe Township and McKees Rocks :
Borough, Allegheny County. :

**PREHEARING CONFERENCE MEMORANDUM
OF THE
BUREAU OF INVESTIGATION AND ENFORCEMENT**

TO ADMINISTRATIVE LAW JUDGE CONRAD A. JOHNSON:

The Pennsylvania Public Utility Commission’s (“Commission”) Bureau of Investigation and Enforcement (“I&E”) files this Prehearing Conference Memorandum in accordance with Administrative Law Judge (“ALJ”) Conrad A. Johnson’s Prehearing Conference Order for Telephonic Hearing on Remand dated November 3, 2022.

I. HISTORY OF THE PROCEEDING

Pursuant to Section 1.33 of the Commission’s regulations, 52 Pa. Code § 1.33, I&E incorporates the procedural history as set forth in the Opinion and Order dated October 27, 2022, pages 2-4. In the October 27, 2022 Opinion and Order, the Commission granted the Pennsylvania Department of Transportation’s (“PennDOT”)

Petition for Reconsideration/Clarification and remanded the matter to the Office of Administrative Law Judge for a decision on who shall be responsible for the future maintenance and expenses related to the traffic signals and signage on the McKees Rocks bridge where State Route 3104 crosses the tracks of CSX Transportation, Inc. (“CSXT”) (DOT No. 584 825 U), Norfolk Southern Railway Company (“NS” or “Norfolk Southern”) (DOT No. 507 455 K), and the Pittsburgh & Ohio Central Railroad Company (“POHC”) (DOT unknown).

On November 3, 2022, Administrative Law Judge (“ALJ”) Conrad A. Johnson issued a Prehearing Conference Order for Telephonic Hearing on Remand, scheduling a telephonic prehearing conference for December 22, 2022. Additionally, ALJ Johnson instructed the parties to file prehearing memorandum before 4:00 p.m. on December 19, 2022.

II. I&E PREHEARING CONFERENCE MEMORANDUM

A. Service

All service on, and communication to, I&E in this proceeding should be addressed to:

By Mail: Kayla L. Rost
Pennsylvania Public Utility Commission
Bureau of Investigation and Enforcement
Commonwealth Keystone Building
400 North Street
Harrisburg, PA 17120

By Telephone: (717) 787-1888

By E-mail: karost@pa.gov

B. Statement Regarding Settlement

I&E is open and willing to discuss settlement of this matter. Currently, I&E is not aware of any settlement discussions at this time.

C. Plan and Schedule of Discovery

I&E proposes that discovery be conducted consistent with the Commission's regulation at 52 Pa. Code §§ 5.321, *et seq.*

D. Discovery Orders

I&E does not propose any modifications to the Commission's regulations pertaining to discovery at 52 Pa. Code §§ 5.321, *et seq.*

E. Proposed Litigation Schedule

I&E provided a proposed litigation schedule to counsel for PennDOT, Norfolk Southern, CSXT, and McKees Rocks Borough. Counsel for PennDOT and McKees Rocks Borough responded with no objection to I&E's proposed schedule. Accordingly, I&E proposes the following litigation schedule:

Written direct testimony:	March 1, 2023
Written rebuttal testimony:	April 3, 2023
Witness schedule:	3 business days before the hearing
Hearing:	Week of May 8, 2023 - The parties agree that only one day will be needed for the evidentiary hearing.

Briefing schedule to be established at the hearing.

F. Names and Addresses of Witness(es) to be Presented

Daniel R. Helfrich, P.E.
Pennsylvania Public Utility Commission
Bureau of Technical Utility Services
Transportation Division- Rail Section
400 North Street
Harrisburg, PA 17120
(717)787-5189
dhelfrich@pa.gov

I&E reserves the right to modify the identified witness and/or present additional witnesses as it deems necessary based on the issues identified by the parties.

1. Issue to be Addressed

Issue: Which party or parties shall be assigned future maintenance and costs associated with the traffic signals and signage on the bridge.

I&E's Position: As shown in I&E Exhibit A, attached hereto, the Commission's jurisdiction as established in the March 10, 2021 Secretarial Letter does not extend to the traffic signals where the McKees Rocks Bridge intersects with Island Avenue or State Route 65. Accordingly, I&E and Rail Safety hold the position that PennDOT should be assigned the maintenance and costs associated with the signage on the bridge.

2. Statement of Evidence to be Presented

Mr. Helfrich will testify to all matters pertaining to the public safety, present conditions, existing maintenance, and future maintenance at the subject bridge crossing. Mr. Helfrich may testify to additional matters based upon the issues identified by the parties.

Respectfully submitted,



Kayla L. Rost
Prosecutor
PA Attorney ID No. 322768

Pennsylvania Public Utility Commission
Bureau of Investigation and Enforcement
Commonwealth Keystone Building
400 North Street
Harrisburg, PA 17120
Phone: (717) 787-1888
Email: karost@pa.gov

Dated: December 19, 2022

I&E
Exhibit A

GENERAL NOTES:

1. PROVIDE MATERIALS AND PERFORM WORK IN ACCORDANCE WITH SPECIFICATIONS PUBLICATION 408/2016 LATEST EDITION, AASHTO/AWS BRIDGE WELDING CODE D1.5/D1.5M - 2008 AND CONTRACT SPECIAL PROVISIONS.
2. DESIGN SPECIFICATIONS:
ALLOWABLE STRESS DESIGN - 2002 AASHTO STANDARD SPECIFICATIONS FOR HIGHWAY BRIDGES, SEVENTEENTH EDITION, INCLUDING INTERIM REVISIONS AND AS SUPPLEMENTED BY DESIGN MANUAL, PART 4, 1996 FOR ANALYSIS OF EXISTING MEMBERS AND MEMBER REPAIRS.
3. DESIGN LIVE LOADS:
H20, HS20, ML80 AND TK527
4. A TEMPORARY CLEARANCE ENVELOPE IS TO BE MAINTAINED OVER THE CSX RAILROAD TRACKS DURING CONSTRUCTION. THE ENVELOPE IS TO PROVIDE A MINIMUM VERTICAL CLEARANCE OVER THE TRACKS OF 23'-0" MEASURED WITHIN 6'-0" FROM THE CENTERLINE OF ALL THE TRACKS.

SCOPE OF WORK:

- PIER 1 - REPLACE TORN TOOTH EXPANSION DAM DRAINAGE TROUGH.
- REPLACE APPROACH SLABS AT NEAR AND FAR ABUTMENTS
- REPAIR FACE OF BRIDGE DECK CONCRETE BARRIERS
- INSTALL NEW SIDEWALK PROTECTIVE FENCE TO THE UPSTREAM AND DOWNSTREAM PORTIONS OF THE SIDEWALK OVER THE RAILROAD

LEGEND:

- F - FIXED PIN BEARING
- E - EXPANSION ROCKER BEARING
- EXP. - EXPANSION
- STA. - STATION
- ➔ - TRAFFIC DIRECTION
- * - MEASURED ALONG THE CONSTR. C
- U. S. - UPSTREAM
- D. S. - DOWNSTREAM

Mark	Description	By	Chk'd.	Recm'd.	Date
REVISIONS					

BMS NO. 02-3104-0010-0320; BRKEY 1868
COMMONWEALTH OF PENNSYLVANIA
 DEPARTMENT OF TRANSPORTATION
ALLEGHENY COUNTY
 S.R. 3104 SECTION A03
 SEGMENT 0010 OFFSET 0320
 S.R. 3104 STA. 5+86
MCKEES ROCKS BRIDGE REHABILITATION
 OVER CSX TRANSPORTATION
TS&L GENERAL PLAN & ELEVATION

RECOMMENDED _____ SHEET 1 OF 1

S-39125

STA. 2+00, PUC
JURISDICTIONAL
LIMIT IN 3/10/2021
SECRETARIAL
LETTER

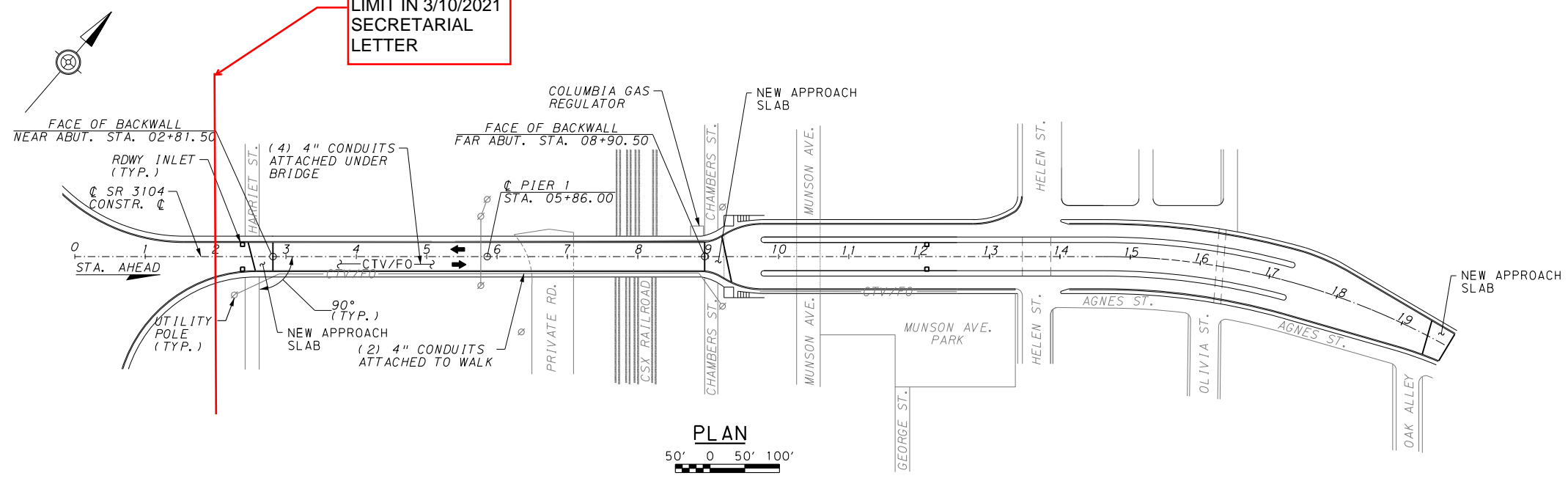

PLAN
50' 0 50' 100'

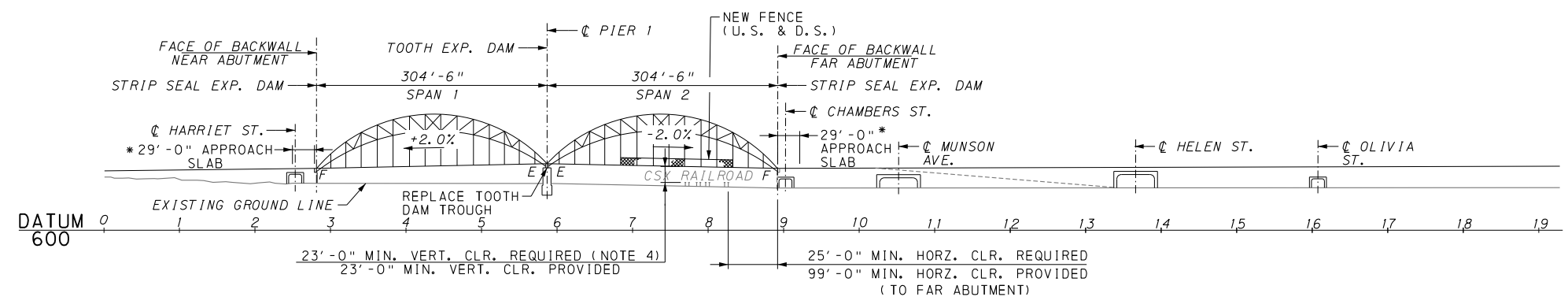

ELEVATION
50' 0 50' 100'

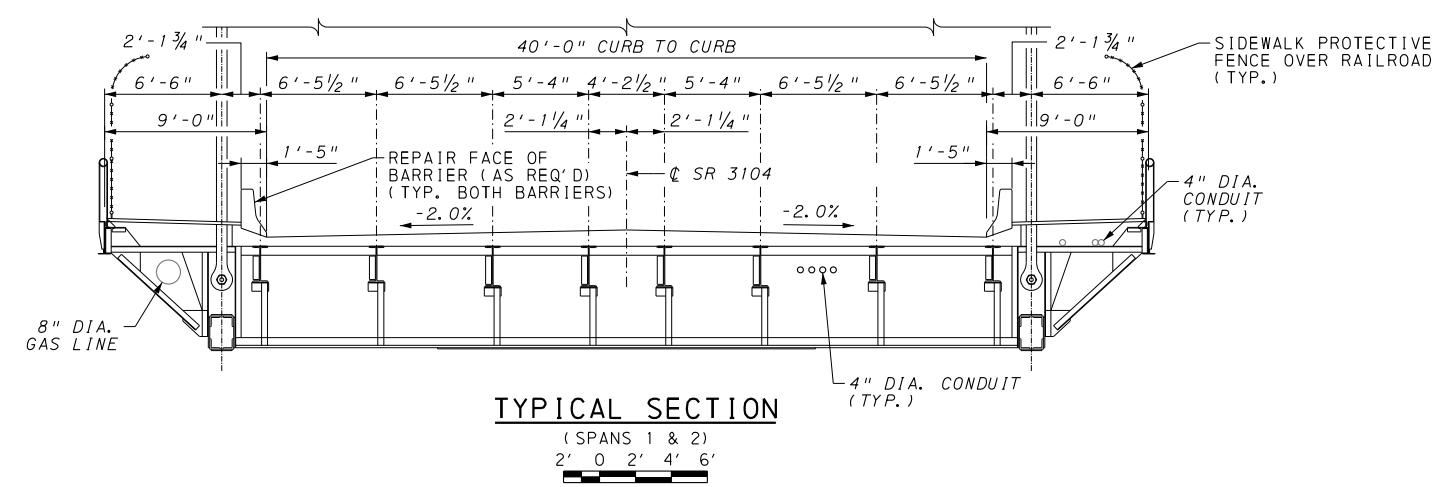

TYPICAL SECTION
(SPANS 1 & 2)
2' 0 2' 4' 6'

\\gfdp10101\cadd\060361 - PDT D11 E03394\WO-1\NE - Prj Wk\g. CADD\TSL\SH101_03_TSL01.dgn 6/16/2020 9:52:47 AM

GENERAL NOTES:

- PROVIDE MATERIALS AND PERFORM WORK IN ACCORDANCE WITH SPECIFICATIONS PUBLICATION 408/2016 LATEST EDITION, AASHTO/AWS BRIDGE WELDING CODE D1.5/D1.5M - 2008 AND CONTRACT SPECIAL PROVISIONS.
- DESIGN SPECIFICATIONS:
 - ALLOWABLE STRESS DESIGN - 2002 AASHTO STANDARD SPECIFICATIONS FOR HIGHWAY BRIDGES, SEVENTEENTH EDITION, INCLUDING INTERIM REVISIONS AND AS SUPPLEMENTED BY DESIGN MANUAL, PART 4, 1996 FOR ANALYSIS OF EXISTING MEMBERS AND MEMBER REPAIRS.
 - LOAD AND RESISTANCE FACTOR DESIGN - AASHTO LRFD 7TH EDITION, 2014 AND AS SUPPLEMENTED BY DESIGN MANUAL, PART 4, 2015 FOR NEW SIDEWALK ELEMENTS.
- DESIGN LIVE LOADS:
 - H20, HS20, ML80 AND TK527
 - SIDEWALK - 90 PSF
- DEAD LOADS:
 - UTILITY LOADS (SIDEWALK):
 - 16" DIAMETER GAS LINE - 85 PLF
 - TWO 2 1/2" DIAMETER CONDUITS - 12 PLF
- RAILROAD:
 - NO EQUIPMENT WILL BE PERMITTED TO BE STORED ON NS PROPERTY WITHOUT PERMISSION FROM THE NS RAILROAD ENGINEER IN ACCORDANCE WITH SECTION E.5.K.1 OF THE NS PUBLIC PROJECTS MANUAL.

SCOPE OF WORK:

- REMOVE AND DISPOSE OF EXISTING NETTING UNDER EACH SIDEWALK
- SIDEWALKS - REPLACE SIDEWALKS WITH CONCRETE FILLED STEEL GRID DECKING AND REPAIR SUPPORTING ELEMENTS AS REQUIRED IN SPANS 1 THRU 10 AND SPANS 12 THRU 9
- REPLACE THE CONCRETE BARRIER ON THE DOWNSTREAM SIDE OF THE BRIDGE IN SPANS 2 THRU 9
- REPLACE OVERHANG DECK CONCRETE WITH TYPE 2 CONCRETE REPAIRS ALONG BOTH THE UPSTREAM AND DOWNSTREAM SIDEWALKS (EXCEPT WHERE THE BARRIER IS BEING REPLACED AND IN SPAN 12)
- PIER 8 - REPLACE NEOPRENE STRIP SEAL GLAND
- FAR ABUTMENT - REPLACE NEOPRENE STRIP SEAL DAM
- FAR ABUTMENT - REPLACE THE TOP OF THE BACKWALL AND PERFORM CONCRETE REPAIRS TO THE REMAINING BACKWALL
- PEDESTRIAN RAIL - REPAIR RIGHT HORIZONTAL RAIL ELEMENTS AT PANEL POINT 17, SPAN 11.
- GUSSET PLATE - REPAIR TWO UPPER CHORD GUSSET PLATES BY ADDING SUPPLEMENTAL PLATES AND STIFFEN THE PLATE EDGES OF SEVENTEEN (17) ADDITIONAL PLATES
- FULL PAINT SIDEWALK SUPPORT ELEMENTS AND TOP CHORD/GUSSETS ADJACENT TO THE SIDEWALK IN SPANS 1 THROUGH 10 AND 12 THROUGH 15.
- FULL PAINT THE PEDESTRIAN RAILING IN ALL SPANS ALONG BOTH SIDEWALKS
- REPLACE THE APPROACH SLABS AT NEAR AND FAR ABUTMENTS
- PERFORM DECK SPALL REPAIRS AT ONE LOCATION IN BOTH SPANS 11 AND 13
- REPAIR FACE OF BRIDGE DECK CONCRETE BARRIERS
- INSTALL NEW SIDEWALK PROTECTIVE FENCE TO THE UPSTREAM AND DOWNSTREAM SIDEWALKS IN PORTIONS OF SPANS 10 AND 14 OVER THE RAILROAD

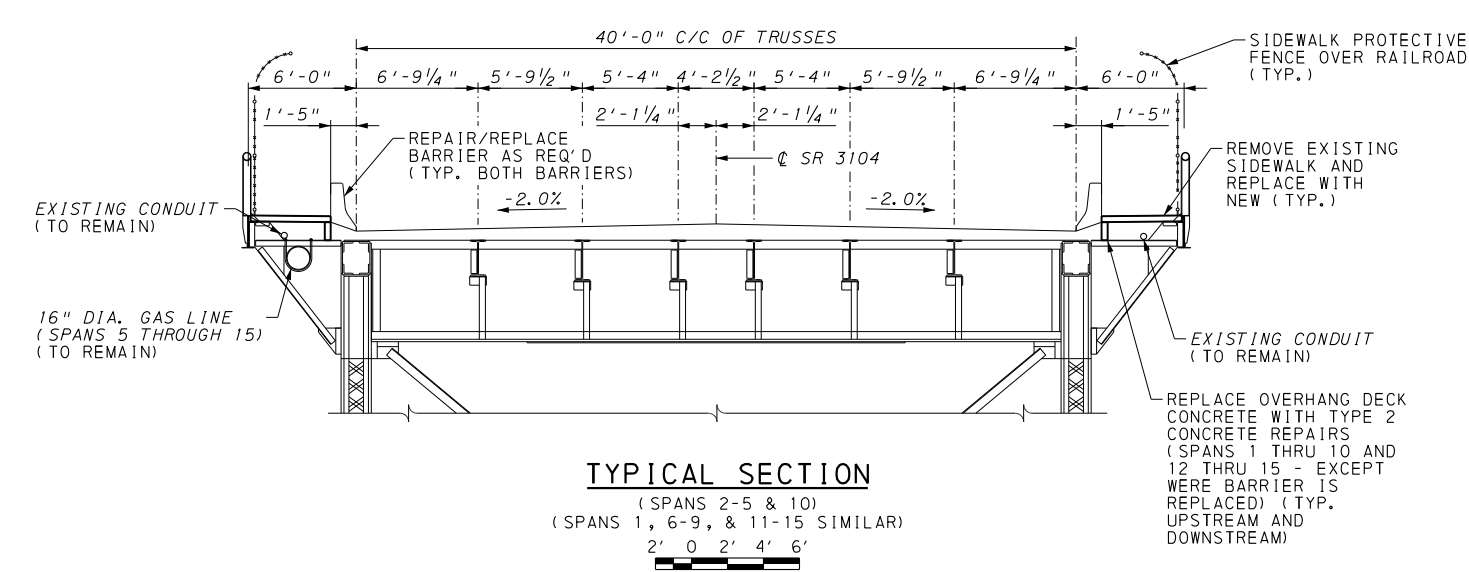
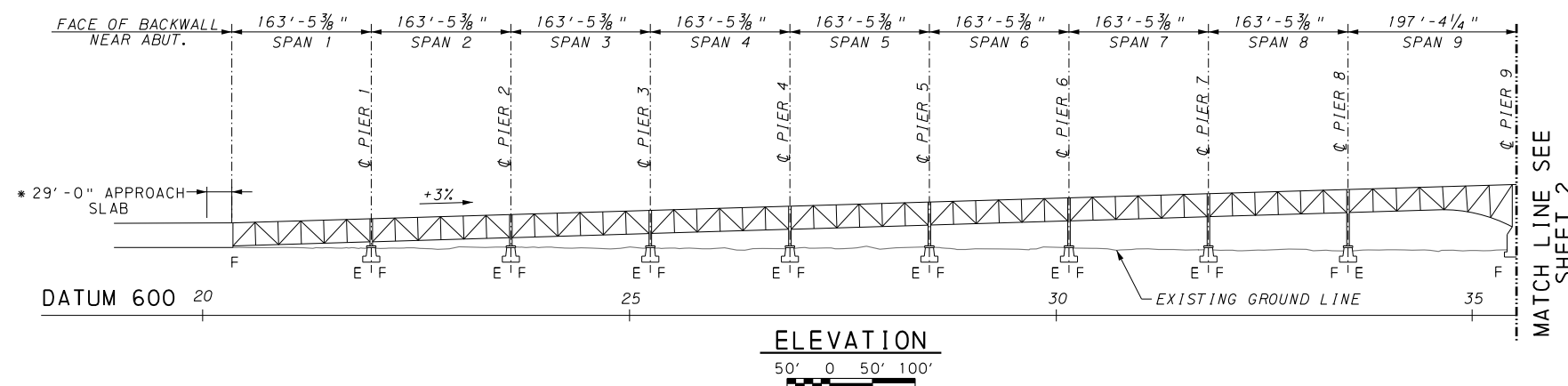
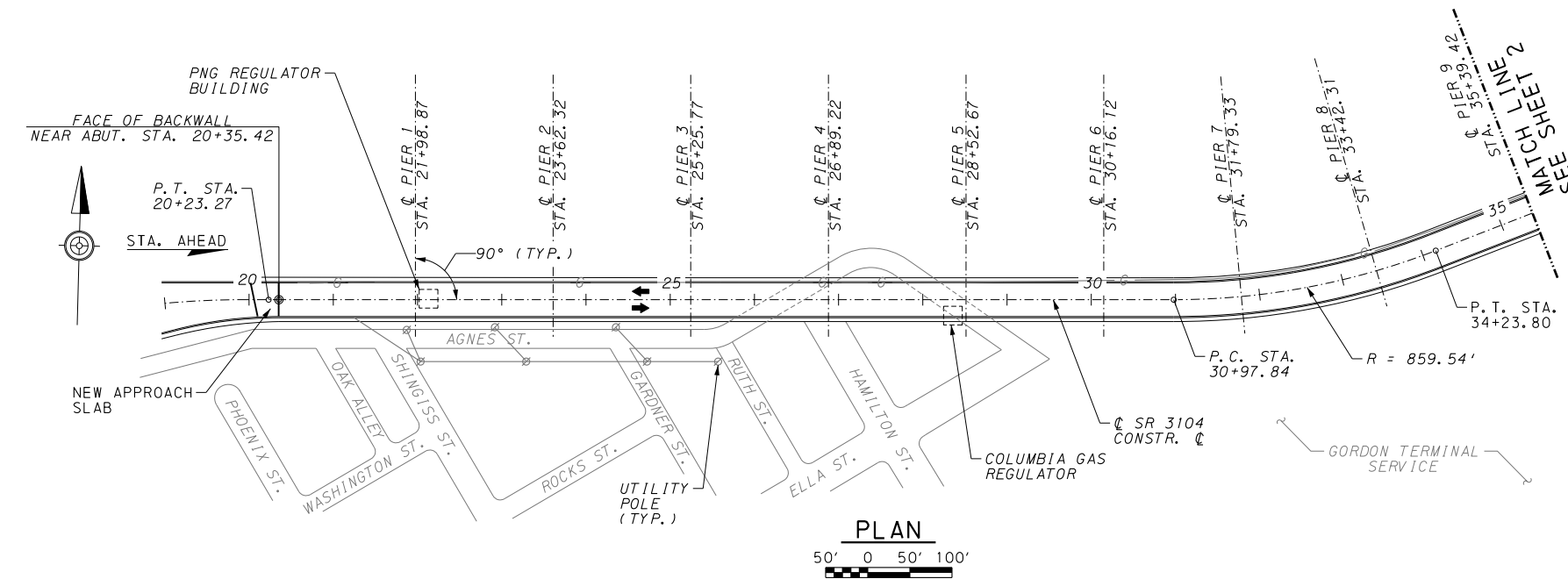

LEGEND:

- F - FIXED PIN BEARING
- EXP. - EXPANSION ROCKER BEARING
- STA. - STATION
- ➔ - TRAFFIC DIRECTION
- PNG - PEOPLES NATURAL GAS
- * - MEASURED ALONG CONSTR. C.
- U.S. - UPSTREAM
- D.S. - DOWNSTREAM

Mark	Description	By	Chk'd.	Recm'd.	Date
REVISIONS					

BMS NO. 02-3104-0030-0000; BRKEY 1876

COMMONWEALTH OF PENNSYLVANIA
DEPARTMENT OF TRANSPORTATION

ALLEGHENY COUNTY
S.R. 3104 SECTION A03
SEGMENT 0030 OFFSET 0000
S.R. 3104 STA. 38+75
MCKEES ROCKS BRIDGE REHABILITATION
OVER OHIO RIVER & NORFOLK SOUTHERN RAILROAD

TS&L GENERAL PLAN & ELEVATION-1

RECOMMENDED _____	SHEET 1 OF 8
S-39126	

\\gfd101\is\CADD\060361 - PDT D11 E03394\WO-1\E. Prj Wrk\g. CADD\TSL\SH101_TSL02.dgn
 6/4/2020 9:41:37 AM

STA. 58+00, PUC
JURISDICTIONAL
LIMIT IN 3/10/2021
SECRETARIAL
LETTER

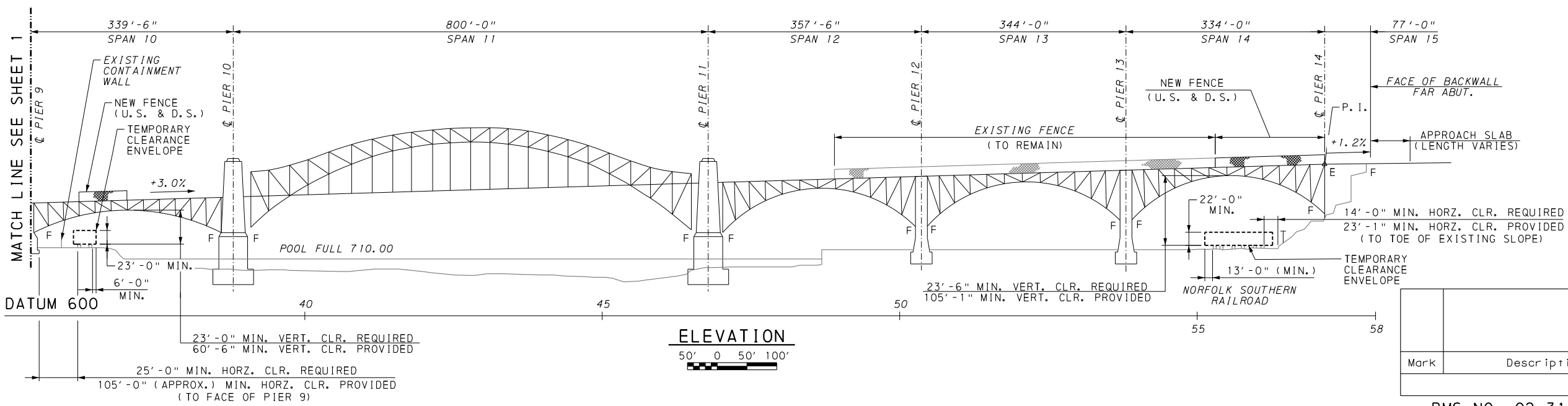
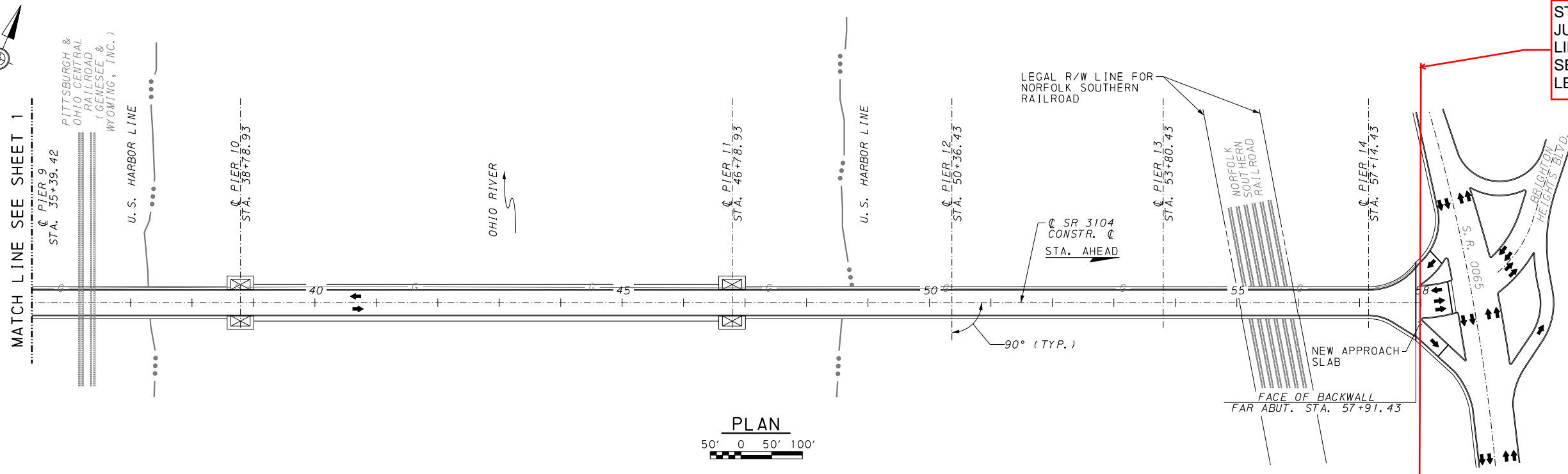

Mark	Description	By	Chk'd.	Recm'd.	Date
REVISIONS					

BMS NO. 02-3104-0030-0000; BRKEY 1876

COMMONWEALTH OF PENNSYLVANIA
DEPARTMENT OF TRANSPORTATION

ALLEGHENY COUNTY
S.R. 3104 SECTION A03
SEGMENT 0030 OFFSET 0000
S.R. 3104 STA. 38+75

MCKEES ROCKS BRIDGE REHABILITATION
OVER OHIO RIVER & NORFOLK SOUTHERN RAILROAD

TS&L GENERAL PLAN & ELEVATION-2

RECOMMENDED _____

SHEET 2 OF 8

S-39126

NOTES:
1. SEE SHEET 1 FOR ADDITIONAL NOTES AND LEGEND.

\\gfp10101\cadd\060361 - PDT D11 E03394\MO.I\E. Prj Wrk\G. CADD\TSL\SH202_TSL03.dgn
 6/16/2020 8:40:51 AM

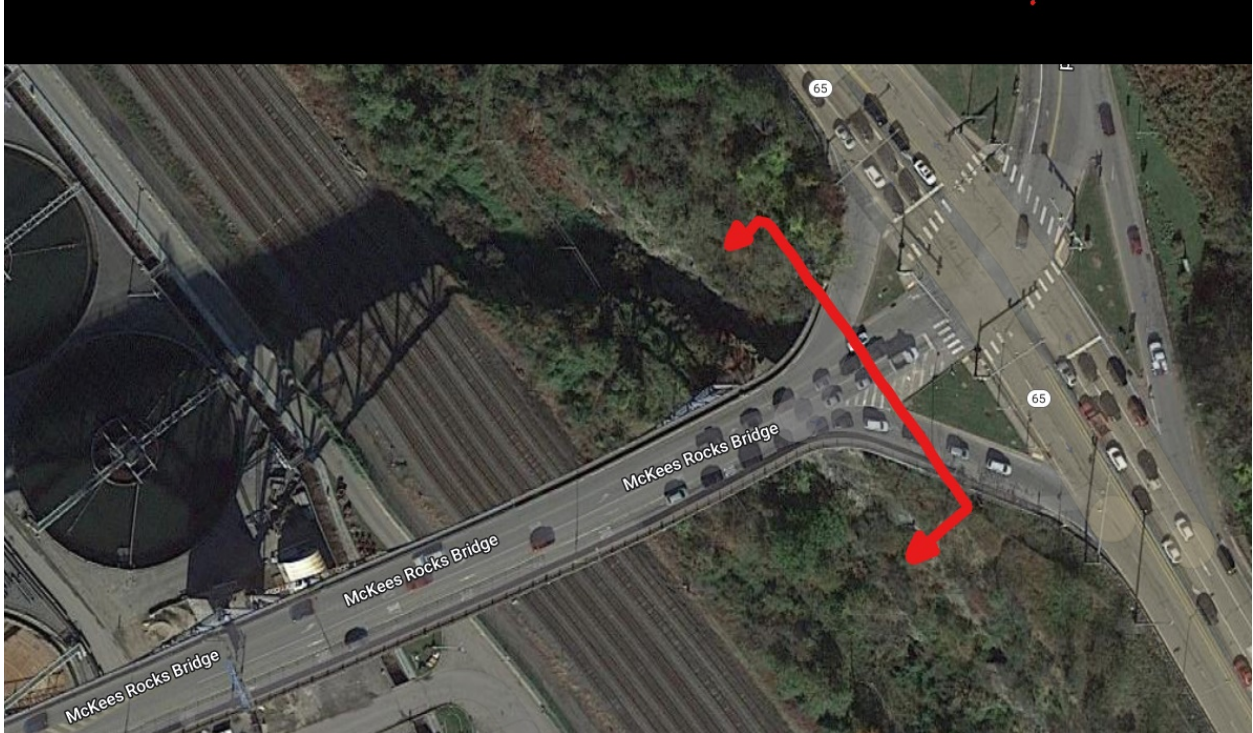

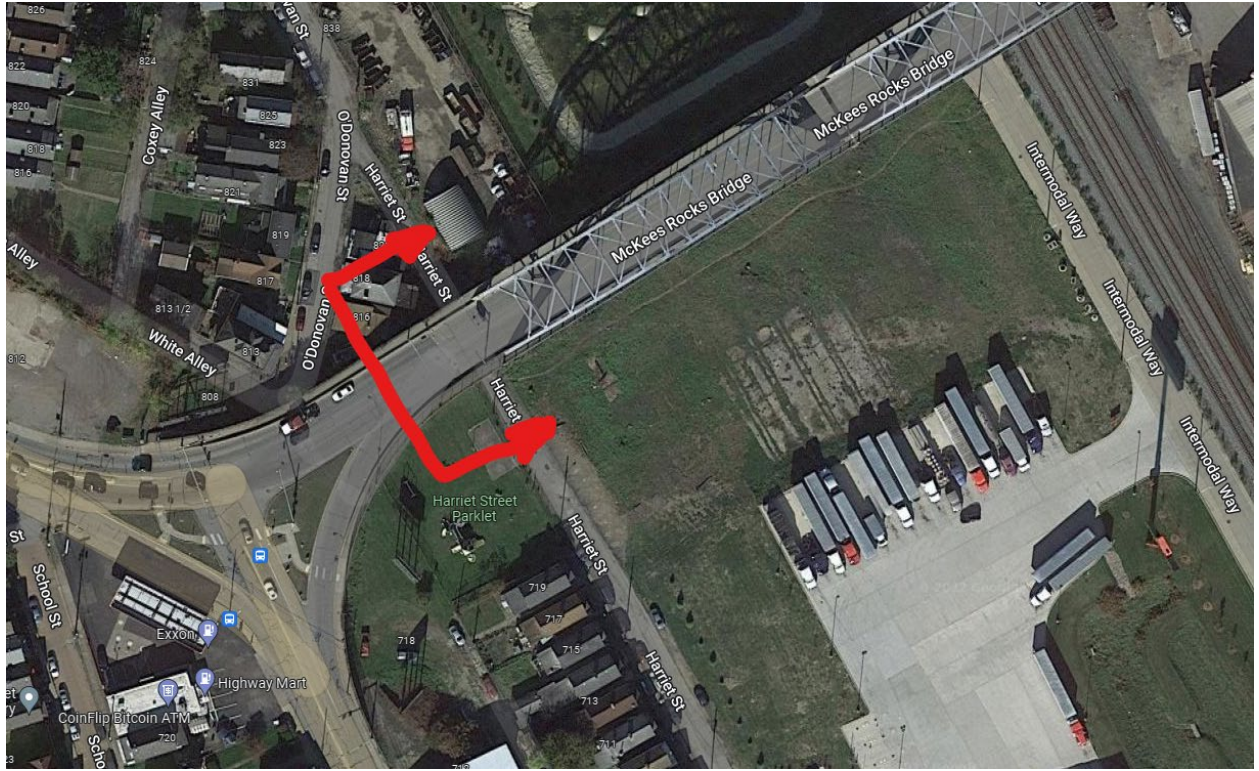

**BEFORE THE
PENNSYLVANIA PUBLIC UTILITY COMMISSION**

Application of the Department of :
Transportation of the Commonwealth of :
Pennsylvania for approval to alter the :
crossings where State Route 3104 :
crosses, above grade, the tracks of CSX :
Transportation Inc. (DOT 584 825 U), : Docket No. A-2020-3020667
Norfolk Southern Railway Company :
(DOT 507 455 K), and the Pittsburgh and :
Ohio Central Railroad Company (DOT :
Unknown) in the City of Pittsburgh, :
Stowe Township and McKees Rocks :
Borough, Allegheny County. :

CERTIFICATE OF SERVICE

I hereby certify that I have this day served a true copy of the foregoing **Prehearing Conference Memorandum** dated December 19, 2022, upon the parties listed below, in accordance with the requirements of 52 Pa. Code § 1.54 (relating to service by a party).

Service by Electronic Mail Only

Honorable Conrad A. Johnson
Administrative Law Judge
Pennsylvania Public Utility Commission
Piatt Place, Suite 220
301 Fifth Avenue
Pittsburgh, PA 15222
cojohnson@pa.gov

Benjamin C. Dunlap Jr., Esquire
Nauman Smith Shissler & Hall
200 North Third Street, 18th Floor
Harrisburg, PA 17101
bdunlapjr@nssh.com
*Counsel for Norfolk Southern Railway
Company and CSX Transportation Inc.*

Eric W. White, Esquire
Pennsylvania Department of
Transportation
Office of Chief Counsel
P.O. Box 8212
Harrisburg, PA 17105-8212
ewwhite@pa.gov

Megan M. Turnbull, Esquire
Danielle Guarascio, Esquire
Weiss Burkardt Kramer LLC
445 For Pitt Blvd., Suite 503
Pittsburgh, PA 15219
mturnbull@wbklegal.com
dguarascio@wbklegal.com
Counsel for McKees Rocks Borough

Chris Hornstein
Dept. Public Works, City of Pittsburgh
Room 301
City County Building
414 Grant Street, 3rd Fl.
Pittsburgh, PA 15219
Chris.Hornstein@pittsburghpa.gov

Roberta Farls
Dwight Boddorf
Stowe Township
555 Broadway Avenue
McKees Rocks, PA 15136
Secretary@stowetwp.net

Jared Rishel
G&W Northeast West Roads
201 N Penn Street
Punxsutawney, PA 15767
jrishel@gwrr.com

Rich Fitzgerald
Allegheny County Executive
101 County Courthouse
436 Grant Street
Pittsburgh, PA 15219
executive@alleghenycounty.us

Frank Halas
Windstream
1003 Treasure Lake
Dubois, PA 15801
Frank.Halas@windstream.com

Joseph Williams
Owner/Operator J. M. Williams
1921 Farr St.
Scranton, PA 18504
J.m.williamsllc@gmail.com

Ruth A. Pompey
McKees Rocks Borough
340 Bell Avenue
McKees Rocks, PA 15136
manager@mckeesrockspa.us

Michael W. Denny
Design Manager
Peoples
375 North Shore Drive
Pittsburgh, PA 15212
michael.denny@peoples-gas.com

Debbie Delia
Verizon Pennsylvania LLC
15 East Montgomery Avenue, 2nd Floor
Pittsburgh, PA 15212
deborah.d.delia@verizon.com

Kyle Tessmer
Duquesne Light Company
2825 New Beaver Avenue, Building 6
Pittsburgh, PA 15233
ktessmer@duqlight.com

Ford McLean
AT&T Local Network Services
3487 Beck Road
Butler, PA 16002
fmclean@att.com

Arletta Scott Williams
Allegheny County Sanitary Authority
(ALCOSAN)
3300 Preble Avenue
Pittsburgh, PA 15233-1092
leah.berfiled@alcosan.org

Dominic Tarella
Columbia Gas of PA, Inc.
4000 Energy Drive
Bridgeville PA 15017
dtarella@nisource.com

Rick Moslen
Comcast Central Office
1530 Chartiers Ave.
Pittsburgh, PA. 15204
Richard_Moslen@cable.comcast.com

George Koleck
The Municipal Authority of
Borough of West View – Water
2428 Rochester Road
Pittsburgh, PA 15143
gkoleck@wvauthority.com

Stephen L. Putt
Level 3 Communications
200 Technology Drive
Pittsburgh, PA 15219
Stephen.Putt@centurylink.com

Brad LeViere
Century Link (United Telephone)
160 Unionville Road
Butler, PA 16001
Bradley.n.leviere@centurylink.com

Amanda Peterson
Shell Appalachia / Shell Oil Co.
2100 Georgetown Drive
Sewickley, PA 15143
appalachia@shell.com

Robert A. Weimar
Pittsburgh Water & Sewer Authority
(PWSA)
Penn Liberty Plaza 1
1200 Penn Avenue
Pittsburgh, PA 15222
rweimar@pgh2o.com



Kayla L. Rost
Prosecutor
Bureau of Investigation and Enforcement
PA Attorney ID No. 322768
(717) 787-1888
karost@pa.gov