



Verizon Pennsylvania LLC
Right of Way Department

Cell 724-636-9515
Phone 724-652-6375
Kathleen.Meeks@verizon.com

Kathleen Meeks
40 S Mercer St
New Castle, PA 16101

September 22, 2023

Ms. Rosemary Chiavetta, Secretary
PA Public Utility Commission
P O. Box 3265
Harrisburg, PA 17105-3265

RE:DOT #145585E

City of Washington, Washington County

Dear Ms. Chiavetta:

Enclosed is an application to the PUC for Verizon Pennsylvania LLC to place a fiber optic cable crossing in the City of Washington, County of Washington and must cross the CSX Railroad, in the public right of way of Dunn Avenue, Crossing #145585E.

All parties have been notified.

Sincerely

A handwritten signature in black ink that reads "Kathleen Meeks".

Kathleen Meeks
Engineer III-Specialist

**BEFORE
PENNSYLVANIA PUBLIC UTILITY COMMISSION**

In re: Application of Verizon Pennsylvania LLC for approval to place an aerial fiber optic cable located in the City of Washington, Washington County. To complete this work, we must cross CSX Railroad in the public right of way of Dunn Avenue, Crossing #145585E

Application
Docket No.

To Pennsylvania Public Utility Commission:

1. The name and address of applicant are
Verizon Pennsylvania LLC
Attn: Kathleen Meeks
40 S. Mercer St.
New Castle, PA 16101

-
2. The name and address of applicant's attorney are

Susan D. Paiva
Assistant General Counsel
900 Race Street
6th Floor
Philadelphia, PA 19107

3. Verizon Pennsylvania LLC requests permission to place an aerial fiber optic cable in the City of Washington, Washington County. **Projected Start Date for this project is November 1, 2023.**

4. The proposed construction will involve a placement of an aerial fiber optic cable attached to existing Verizon poles (Exhibit A)

5. The municipalities and property owners concerned in, or affected by, the crossing alterations are in Exhibit "B".

6. The motoring public and railroad traffic will not be impacted. Verizon Pennsylvania LLC will use normal construction procedures. Normal procedures will be followed including the use of *flagmen to maintain normal flow of traffic.*

7. The estimated cost of this construction project is \$1900.00 Completion Date April 15, 2023.

8. The construction is necessary or proper for the following reasons: For Verizon to expand service availability to customers.

Wherefore, applicant prays your Honorable Commission to approve the application:

Kathleen Meeks

1.36. Verification.

(a) Applications, petitions, formal complaints, motions and answers thereto containing an averment of fact not appearing of record in the action or containing a denial of fact shall be personally verified by a party thereto or by an authorized officer of the party if a corporation or association. Verification means a signed written statement of fact supported by oath or affirmation or made subject to the penalties of 18 Pa. C.S. §4904 (relating to unsworn falsification to authorities). If verification is required, notarization is not necessary.

(b) The Verification form should comply substantially with the following:

VERIFICATION

I, Kathleen Meeks, hereby state that the facts above set forth are true and correct (or are true and correct to the best of my knowledge, information and belief) and that I expect to be able to prove the same at a hearing held in this matter. I understand that the statements herein are made subject to the penalties of 18 Pa. C.S. § 4904 (relating to unsworn falsification to authorities).

Date: 09/22/23 Kathleen Meeks
(Signature)

CERTIFICATE OF SERVICE

I hereby certify that I have this day served a true copy of the foregoing document upon the participants, listed below, in accordance with the requirements of § 1.54

Daniel D. Leonard, P.E. | Grade Crossing Engineer
PA Department of Transportation | Bureau of Project Delivery
Highway Delivery Division | Utilities and Right-of-Way Section
400 North Street, 7th Floor | Harrisburg, PA 17120
danleonard@pa.gov

Karen Cummings
Senior Assistant Counsel
Governors Office of General Counsel
Department of Transportation
Office of Chief Counsel/Real Property Division
P.O. Box 8212, Harrisburg, PA 17105-8212
kcummings@pa.gov

Pennsylvania Department of Transportation District 12
825 N. Gallatin Ave
Uniontown, PA 15401

Washington City Hall
55 W Maiden St
Washington, PA 15301

West Penn Power
800 Cabin Hill Dr
Greensburg, PA 15601

CSX Transportation
500 Water St, 15th Floor
Jacksonville, FL 32202

Matt Anderson
Vice President and Chief Engineer
Carload Express, Inc./Allegheny Valley Railroad Company
519 Cedar Way
Bldg 1, Suite 100
Oakmont, PA 15139

Dated this 22nd day of September, 2023



(Signature)

Exhibit B

Daniel D. Leonard, P.E. | Grade Crossing Engineer
PA Department of Transportation | Bureau of Project Delivery
Highway Delivery Division | Utilities and Right-of-Way Section
400 North Street, 7th Floor | Harrisburg, PA 17120
danleonard@pa.gov

Karen Cummings
Senior Assistant Counsel
Governors Office of General Counsel
Department of Transportation
Office of Chief Counsel/Real Property Division
P.O. Box 8212, Harrisburg, PA 17105-8212
kcummings@pa.gov

Pennsylvania Department of Transportation District 10-0
Charles P. Keilman, IV, P.E.
2550 Oakland Ave, PO Box 429
Indiana, PA 15701-0429
chakeilman@pa.gov

Pennsylvania Department of Transportation District 12
825 N. Gallatin Ave
Uniontown, PA 15401

Washington City Hall
55 W Maiden St
Washington, PA 15301

West Penn Power
800 Cabin Hill Dr
Greensburg, PA 15601

CSX Transportation
500 Water St, 15th Floor
Jacksonville, FL 32202
Matt Anderson
Vice President and Chief Engineer
Carload Express, Inc./Allegheny Valley Railroad Company
519 Cedar Way
Bldg 1, Suite 100
Oakmont, PA 15139

Dated this 22th day of September, 2023



(Signature)

METHOD: AERIAL CROSSING
 MUNICIPALITY: WASHINGTON CITY
 COUNTY: WASHINGTON
 CROSSING NUMBER: 145585E
 MILEPOST: 0034.08
 RRSUBDIV: W&P
 LAT: 40.163608
 LONG: -80.223713

**FLAGGING
 REQUIRED**

**CSX TRANSPORTATION PERMIT
 PERMIT SKETCH
 1A5DP7C**

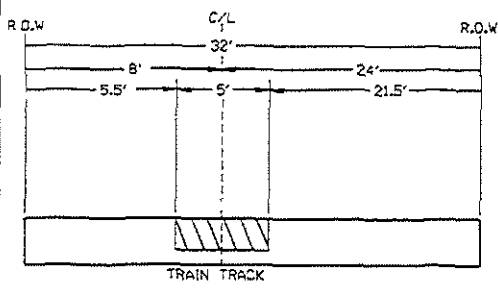
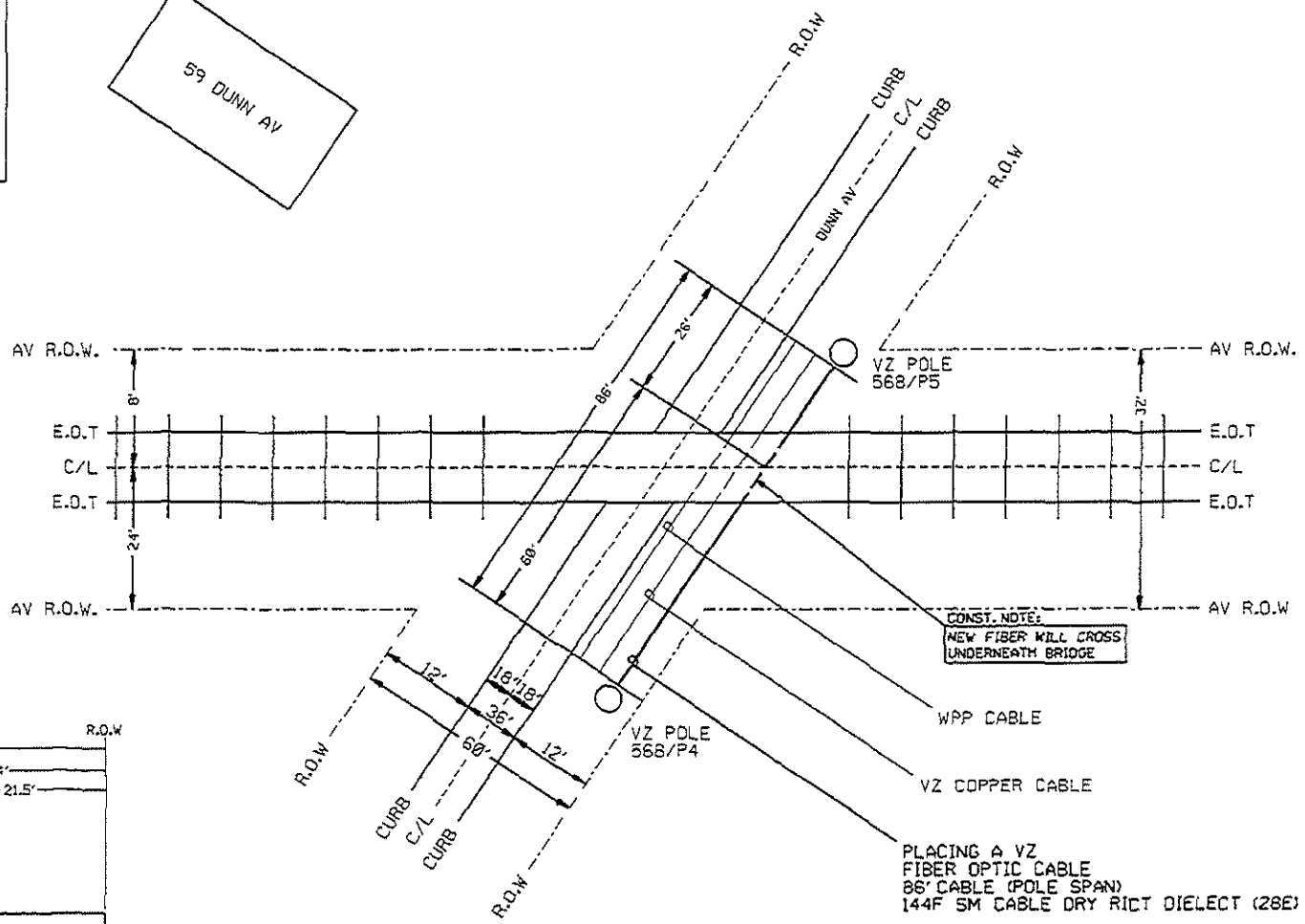
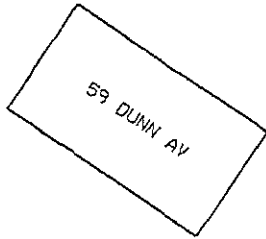

PLACING A VZ
 FIBER OPTIC CABLE
 86' CABLE (POLE SPAN)
 144F SM CABLE DRY RICT DIELECT (28E)

PRINT 1 OF 2
 NOT TO SCALE

CSX TRANSPORTATION PERMIT
PERMIT SKETCH
1A5DP7C

VZ POLE
568/P4

VZ POLE
568/P5

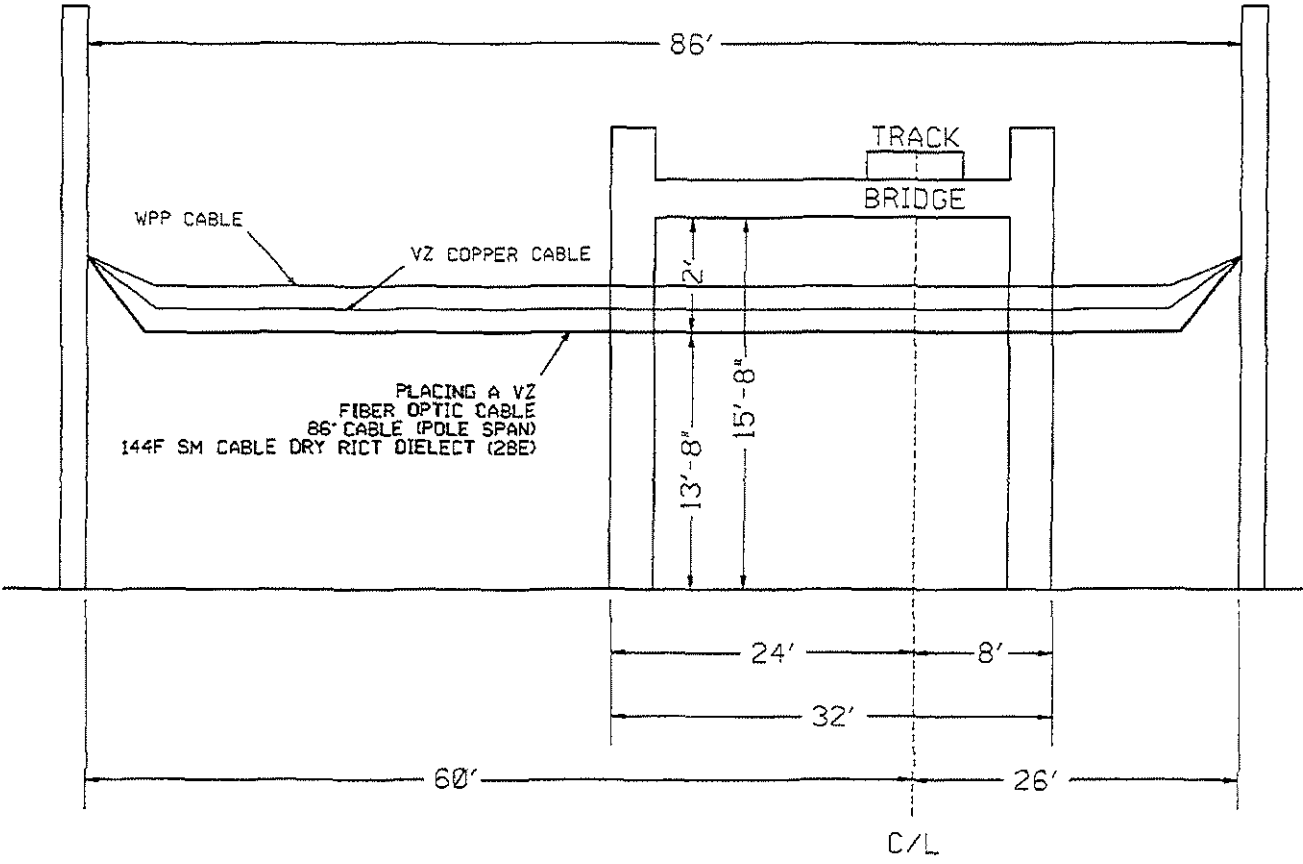

PRINT 2 OF 2
NOT TO SCALE