

---

Devin Ryan

dryan@postschell.com  
717-612-6052 Direct  
717-731-1985 Direct Fax  
File #: 201030

October 27, 2023

***VIA ELECTRONIC FILING***

Rosemary Chiavetta, Secretary  
Pennsylvania Public Utility Commission  
Commonwealth Keystone Building  
400 North Street, 2nd Floor North  
P.O. Box 3265  
Harrisburg, PA 17105-3265

**Re: IN THE MATTER OF THE APPLICATION OF THE YORK WATER  
COMPANY, Under Section 1102(a)(3) of the Public Utility Code, for approval of the  
right of THE YORK WATER COMPANY to acquire the water distribution assets  
of Longstown Mobile Estates in Windsor Township, York County, Pennsylvania  
Docket No. A-2023-3041860**

---

Dear Secretary Chiavetta:

Attached are the responses of The York Water Company to the Data Requests of the Bureau of  
Technical Utility Services, Set I in the above-referenced proceeding.

Respectfully submitted,



Devin Ryan

DR/dmc

cc: Paul Zander (via email [pzander@pa.gov](mailto:pzander@pa.gov); w/att.)

## TUS Data Request Set 1

Application of The York Water Company for approval of the right to acquire certain water system assets from Longstown Mobile Estates in Windsor Township, York County  
Docket No. A-2023-3041860

A-1 The Application did not provide detailed information for the Longstown Mobile Home Park (Longstown MHP) water system assets to be acquired by York Water (the Longstown Water System), and for the proposed water facilities to be constructed or installed by York Water to serve Longstown Water System customers (the Proposed Facilities), including anticipated water meters, meter pits, and meter reading facilities. Please provide the following information for the Longstown Water System and Proposed Facilities:

- a. Provide a map of suitable scale that depicts the location or route of the Longstown Water System and the Proposed Facilities from the point of connection to York Water's existing water facilities. The map needs to identify all pipe sizes and material types of York Water's existing and proposed water mains;
- b. Provide a breakdown of anticipated pipe sizes, material types, and lengths for Proposed Facilities mains and service lines, respectively, and descriptions and quantities for related assets (e.g., meters and meter pits, etc.); and
- c. Provide a breakdown of the cost of construction, by major plant account, of the Proposed Facilities.

### RESPONDENT:

Andrew Prosser, Senior Engineer Manager  
The York Water Company

### RESPONSE:

- a. See **Attachment A-1-1** for details about the Longstown Water System's existing facilities. York Water's existing facilities connect to the Longstown Water System as follows: Grantley Road WTP to the Penn Oakes/Haines Acres Booster Station to the Longstown Water System. York Water owns and maintains a 16-inch water distribution main along East Prospect Road, off of which there is a 4-inch tap and 3-inch service line that currently connect and provide service to the Longstown Water System. None of these existing facilities requires alternation for this acquisition.

In addition, York Water will install meters and meter pits after the acquisition. The exact locations of the meters and meter pits has yet to be determined. There are no other "Proposed Facilities" because the Longstown Water System is already connected to York Water's water distribution system and receives service from York Water as a bulk service customer.

- b. See answer to subpart (a), *supra*, and **Attachment A-1-1**. York Water will install

88 5/8-inch meters and approximately 88 meter pits after the acquisition.

c. See answer subpart (a) in Discovery A-14, *infra*.

# **Attachment A-1-1**

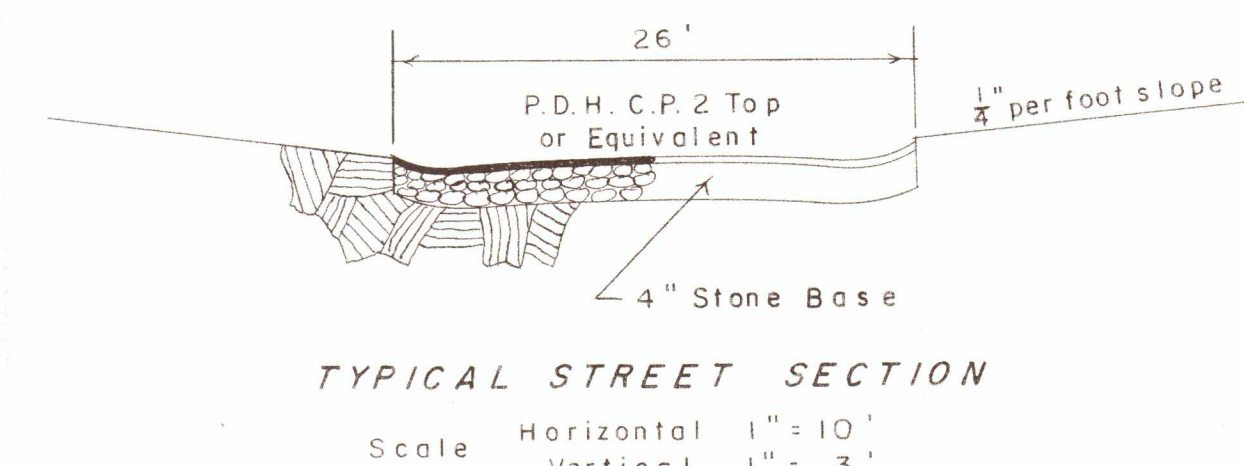
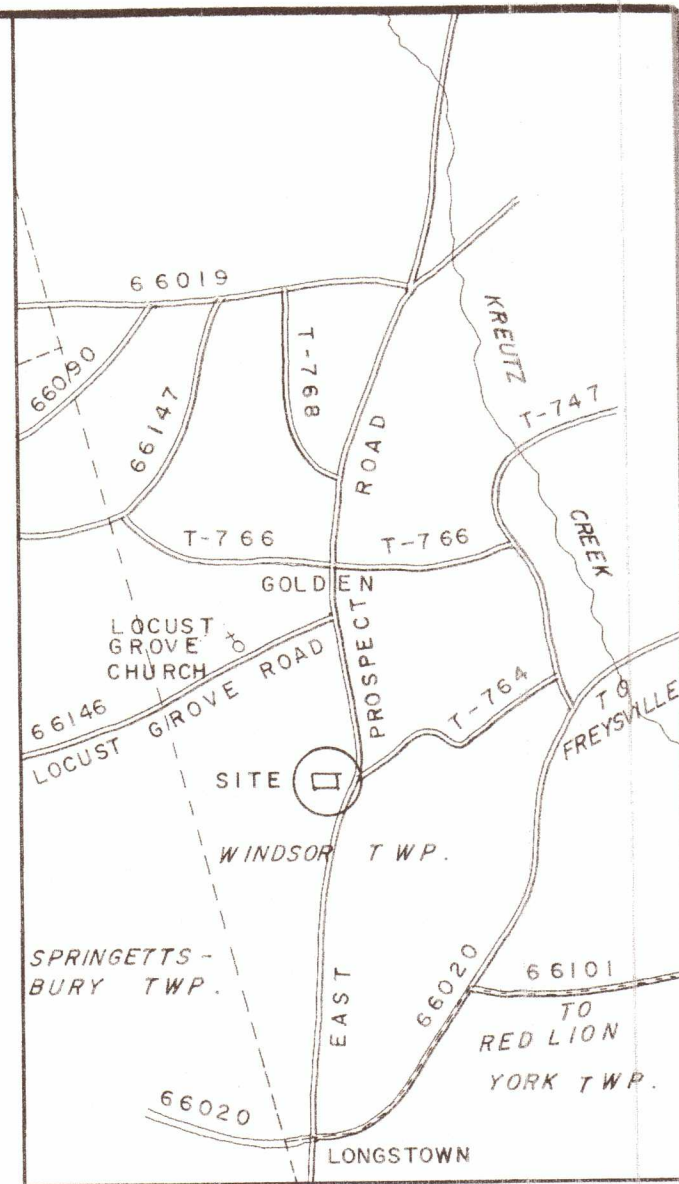
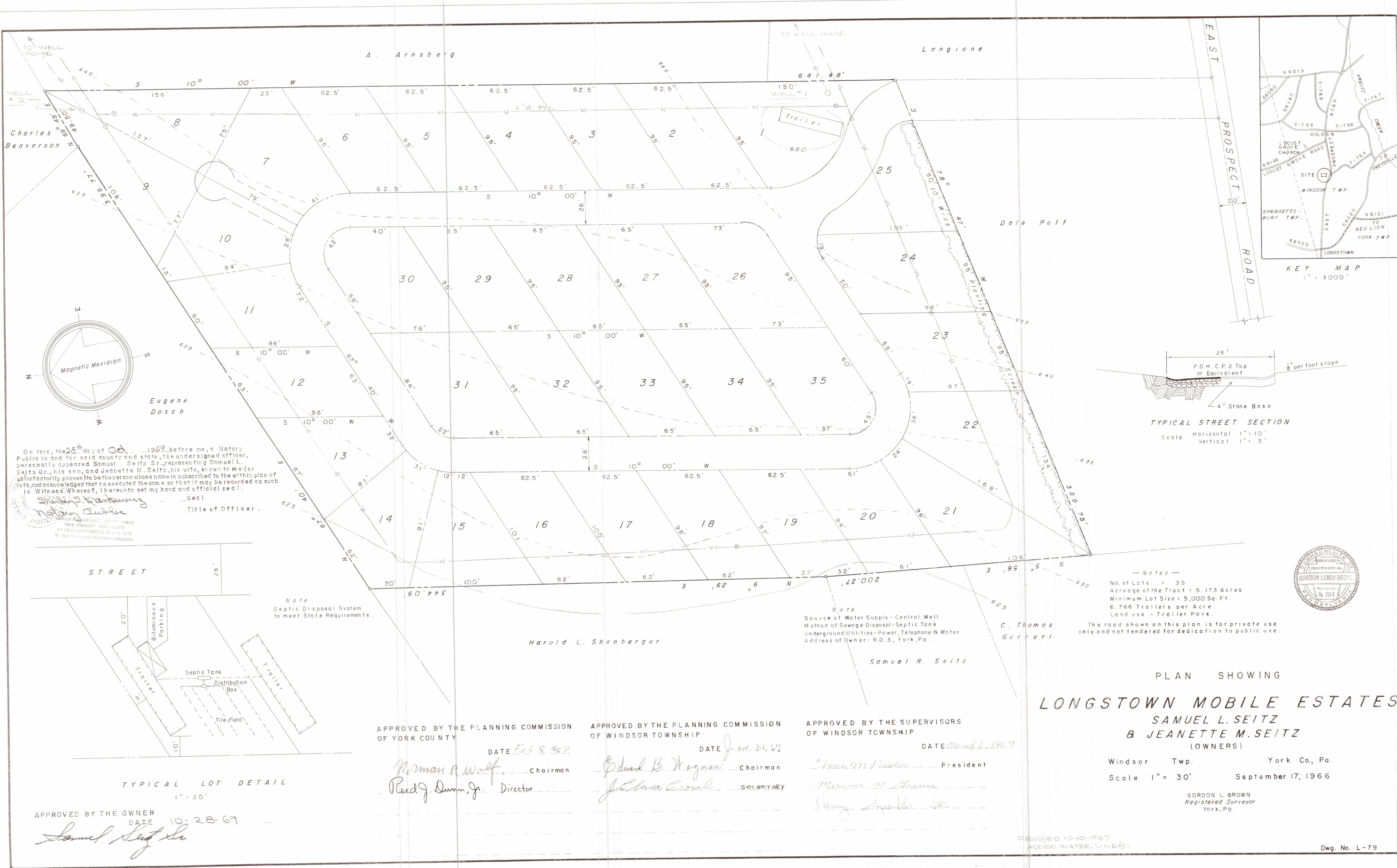

On this, the 28<sup>th</sup> day of Oct. 1967, before me, a Notary Public in and for said county and state, the undersigned officer, personally appeared Samuel L. Seitz Sr., representing Samuel L. Seitz Jr., his son, and Jeanette M. Seitz, his wife, known to me (or satisfactorily proven) to be the person whose name is subscribed to the within plan of lots, and acknowledged that he executed the same so that it may be recorded as such. In Witness Whereof, I hereunto set my hand and official seal.

*Samuel L. Seitz Sr.*  
Notary Public  
Seal  
Title of Officer.

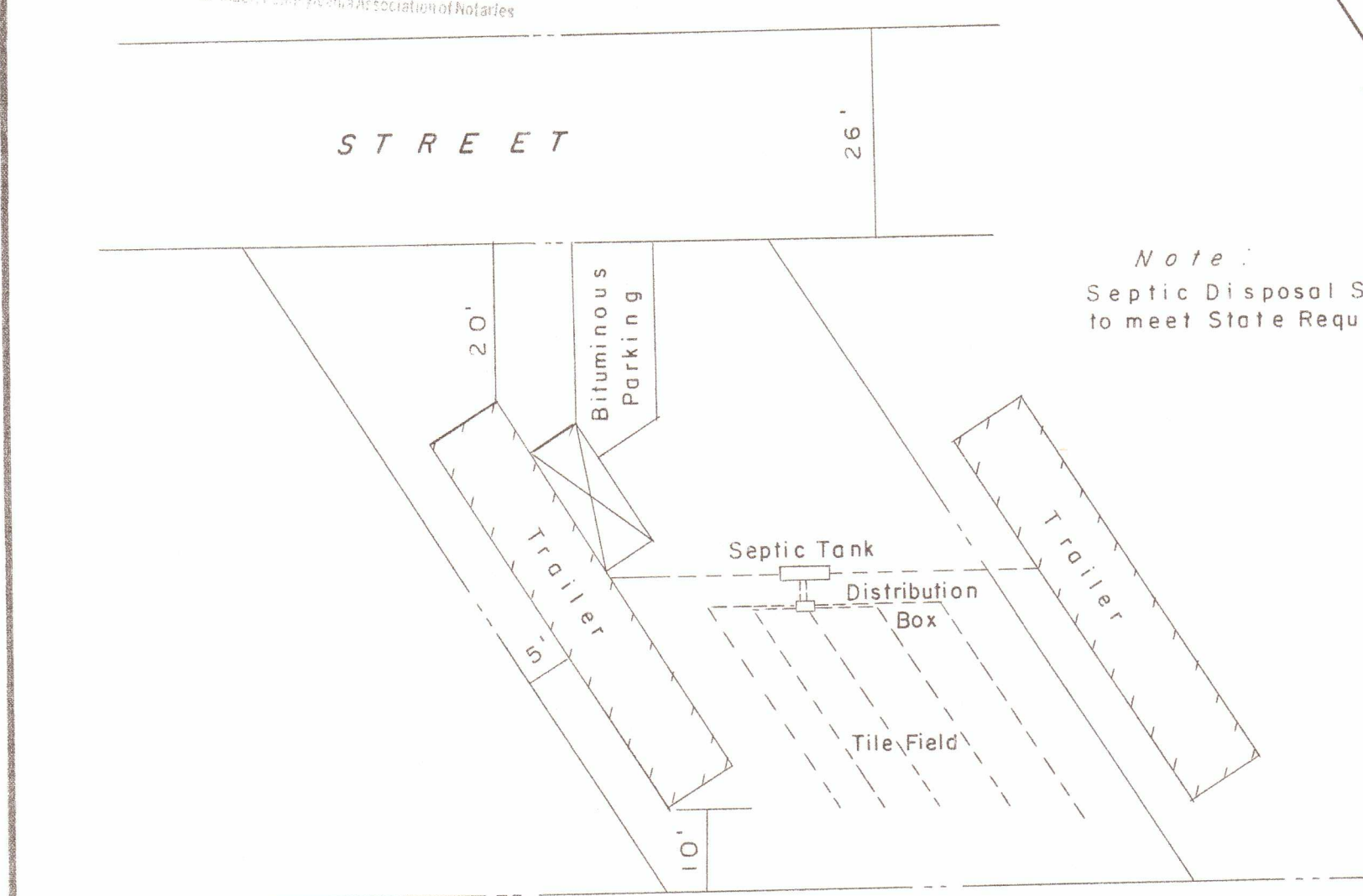

Note: Septic Disposal System to meet State Requirements.

Note: Source of Water Supply - Central Well Method of Sewage Disposal - Septic Tank Underground Utilities - Power, Telephone & Water Address of Owner - R.D. 3, York, Pa.

Notes -  
No. of Lots : 35  
Acreage of the Tract : 5.173 Acres  
Minimum Lot Size : 5,000 Sq. Ft.  
6.766 Trailers per Acre.  
Land use : Trailer Park.  
The road shown on this plan is for private use only and not tendered for dedication to public use.

APPROVED BY THE PLANNING COMMISSION OF YORK COUNTY

DATE Feb 8, 1967

*Norman A. Wolf* Chairman  
*Reed J. Dumm, Jr.* Director

APPROVED BY THE PLANNING COMMISSION OF WINDSOR TOWNSHIP

DATE Jan. 31, 1967

*Edmund B. Wagoner* Chairman  
*J. Elmer Crowl* SECRETARY

APPROVED BY THE SUPERVISORS OF WINDSOR TOWNSHIP.

DATE March 6, 1967

*Edmund A. Seitz* President  
*Merwin M. Strama*  
*Henry J. Spentzell, Sec.*

APPROVED BY THE OWNER  
DATE 10-28-67

*Samuel Seitz Sr.*

PLAN SHOWING  
**LONGSTOWN MOBILE ESTATES**  
SAMUEL L. SEITZ  
& JEANETTE M. SEITZ  
(OWNERS)

Windsor Twp. York Co., Pa.  
Scale 1" = 30' September 17, 1966

GORDON L. BROWN  
Registered Surveyor  
York, Pa.

REVISED 10-10-1967  
ADDED WATER LINES.

Dwg. No. L-79



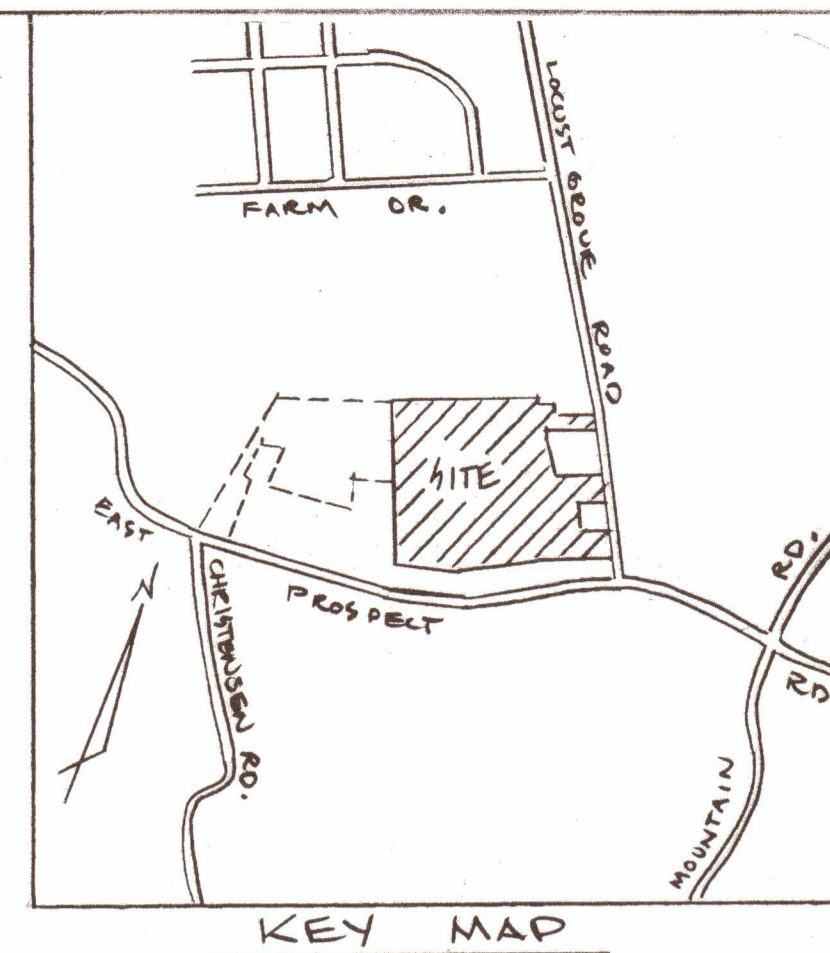
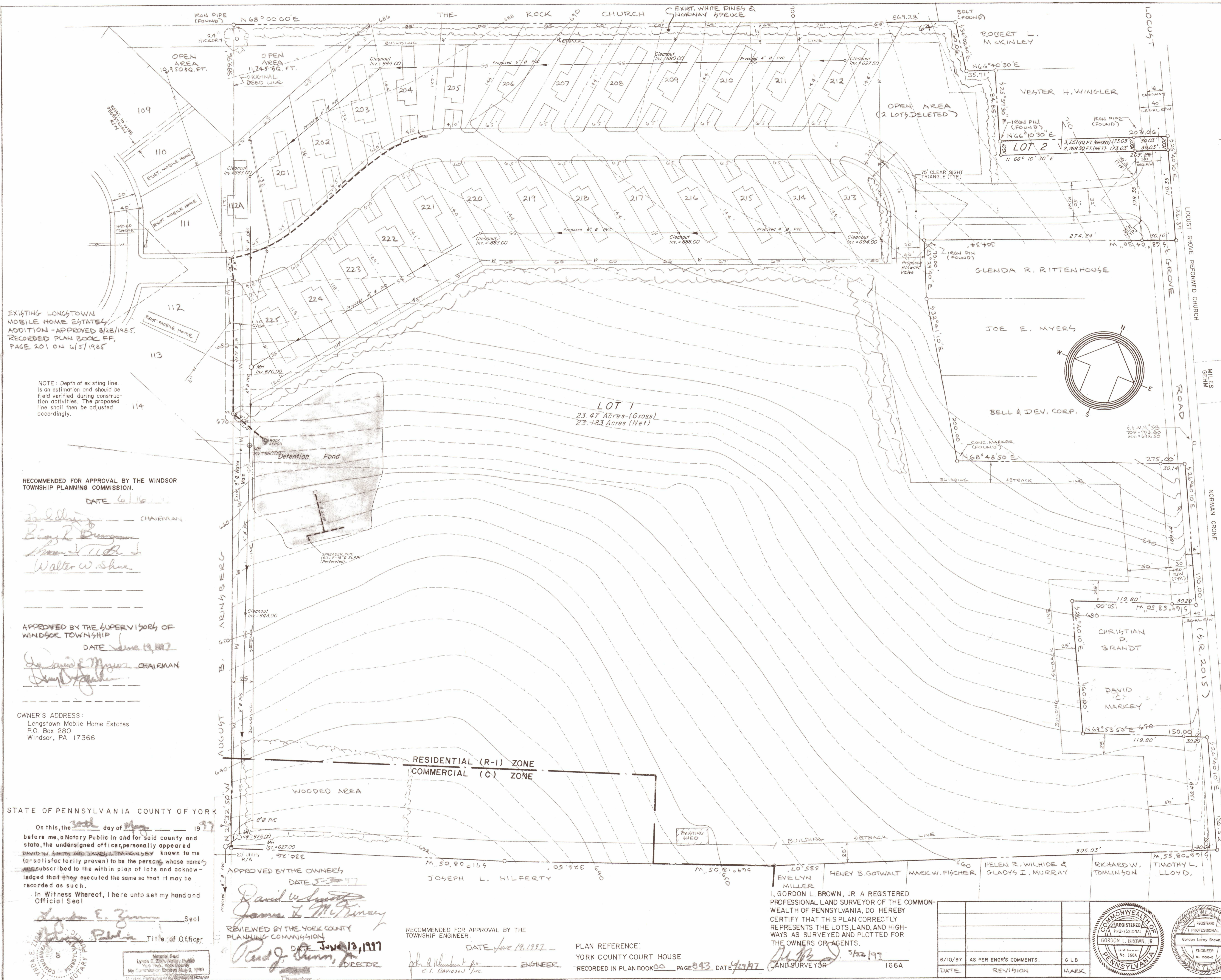

KEY MAP  
 200 400 1000 3000  
 0 400 800 1200 1600  
 SCALE IN FEET 1" = 1000'

EXISTING LONGSTOWN MOBILE HOME ESTATES ADDITION - APPROVED 3/28/1985, RECORDED PLAN BOOK FF, PAGE 201 ON 6/5/1985

NOTE: Depth of existing line is an estimation and should be field verified during construction activities. The proposed line shall then be adjusted accordingly.

RECOMMENDED FOR APPROVAL BY THE WINDSOR TOWNSHIP PLANNING COMMISSION.

DATE 6/16/97  
 Chairman  
 Brian R. Brennan  
 Walter W. Shea

APPROVED BY THE SUPERVISORS OF WINDSOR TOWNSHIP

DATE June 19, 1997  
 Chairman  
 David J. Myers

OWNER'S ADDRESS:  
 Longstown Mobile Home Estates  
 P.O. Box 280  
 Windsor, PA 17366

STATE OF PENNSYLVANIA COUNTY OF YORK

On this, the 30th day of May 1997, before me, a Notary Public in and for said county and state, the undersigned officer, personally appeared DAVID W. SMITH AND JAMES L. MCKINLEY known to me (or satisfactorily proven) to be the persons whose names subscribed to the within plan of lots and acknowledged that they executed the same so that it may be recorded as such.

In Witness Whereof, I here unto set my hand and Official Seal  
 Linda E. Zimm Seal  
 Title of Officer

APPROVED BY THE OWNERS  
 DATE 5-30-97  
 JOSEPH L. HILFERTY  
 HELEN R. WILCHIE & GLADYS I. MURRAY  
 RICHARD W. TOMLINSON  
 TIMOTHY L. LLOYD.

REVIEWED BY THE YORK COUNTY PLANNING COMMISSION  
 DATE June 12, 1997  
 Director

RECOMMENDED FOR APPROVAL BY THE TOWNSHIP ENGINEER.  
 DATE June 19, 1997  
 Engineer

PLAN REFERENCE:  
 YORK COUNTY COURT HOUSE  
 RECORDED IN PLAN BOOK 00 PAGE 843 DATE 4/29/97

I, GORDON L. BROWN, JR. A REGISTERED PROFESSIONAL LAND SURVEYOR OF THE COMMONWEALTH OF PENNSYLVANIA, DO HEREBY CERTIFY THAT THIS PLAN CORRECTLY REPRESENTS THE LOTS, LAND, AND HIGHWAYS AS SURVEYED AND PLOTTED FOR THE OWNERS OR AGENTS.  
 DATE 5/22/97  
 LAND SURVEYOR 166A

DATE	REVISION	MARK
6/10/97	AS PER ENGR'S COMMENTS	GLB

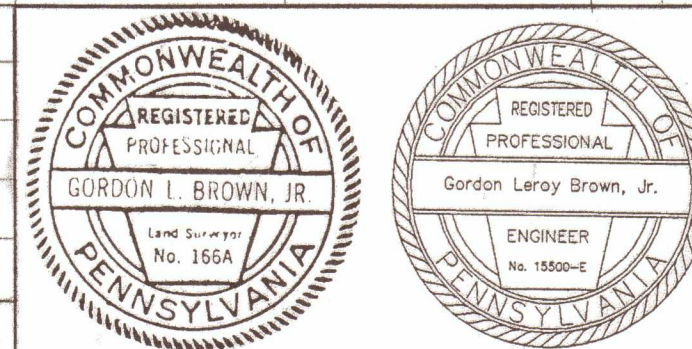

- NOTES & SITE DATA:
- Total Area: 23.54 acres
  - Total No. of Lots: 2
  - Zone: Residential (R-1)
  - Proposed Use: Mobile Home Park Addition
  - Minimum Lot Width: 16' (@ Bldg. line)
  - Minimum Building Setbacks:  
 50' from Locust Grove right-of-way  
 25' from property line  
 15' from interior streets  
 30' from other mobile homes and service buildings
  - Tax Map: J-J, Parcel 163
  - Deed of Record: 96L-1106
  - Minimum Lot Area: 3251 Sq Ft. (Gross)
  - Iron pins shall be placed at all lot corners upon final plan approval.
  - Lot 2 is to be joined with property belonging to Vester H. Wingler as shown hereon and shall not be separated therefrom without the approval of Windsor Township.
  - Previous plan of Longstown Mobile Home Park was approved on 6/26/95 and recorded on 7/6/95. Plan Book NN, Page 649.

I VESTER H. WINGLER HEREBY AGREE TO ACQUIRE LOT 2 AS SHOWN HEREON  
 DATE 6-11-97  
 Vester H. Wingler

GRAPHIC SCALE IN FEET  
 0 20 40 60 80 100 120 140 160 180 200

LONGSTOWN MOBILE HOME ESTATES - 2ND ADDITION  
 DAVID W. SMITH & JAMES L. MCKINLEY  
 WINDSOR TWP.  
 FINAL SUBDIVISION PLAN  
 (LOTS 1 & 2)

DATE: 5/22/97  
 SCALE: 1" = 50'-0"  
 DRAWN BY: MEL  
 CHECKED BY:  
 SHEET NO. 1 OF 1  
 OF 1  
 L-205B-2

GIBB  
 GORDON L. BROWN & ASSOC., INC.  
 2238 S. Queen St. York, PA 17402  
 (717) 741-4821 FAX 741-1418

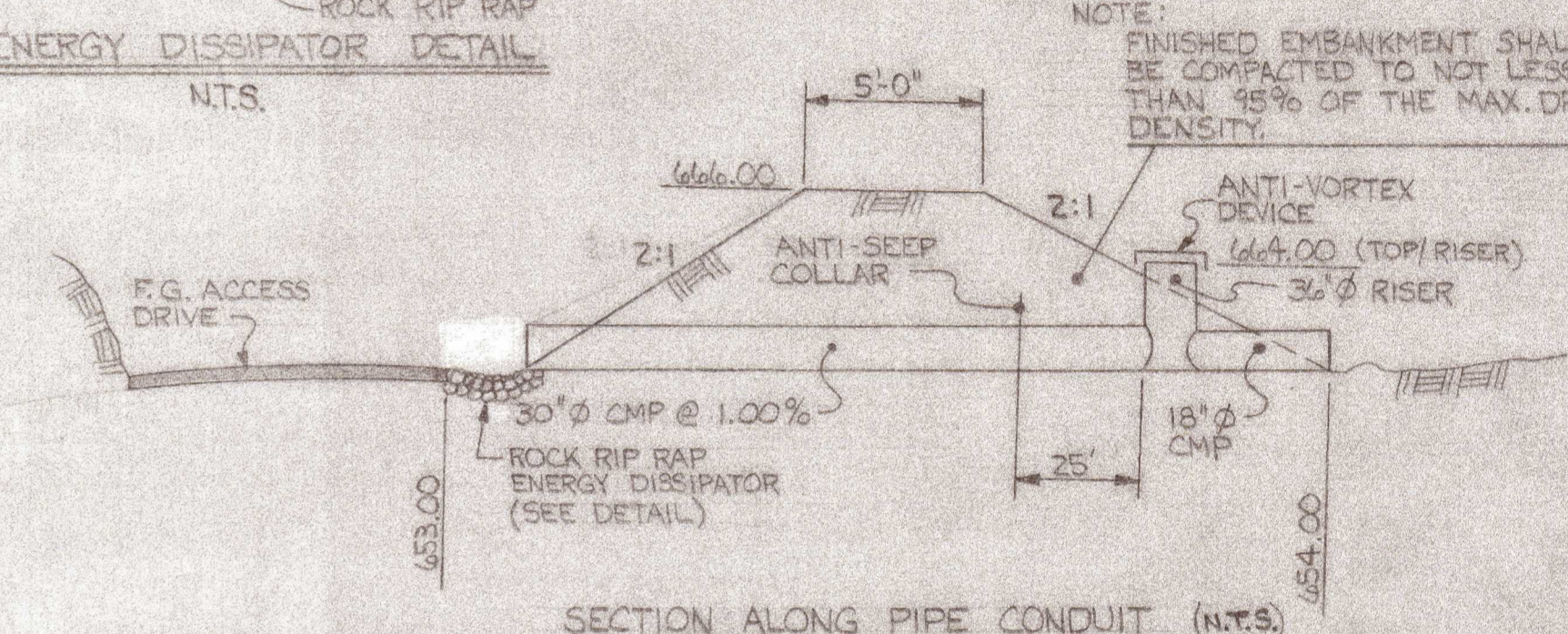
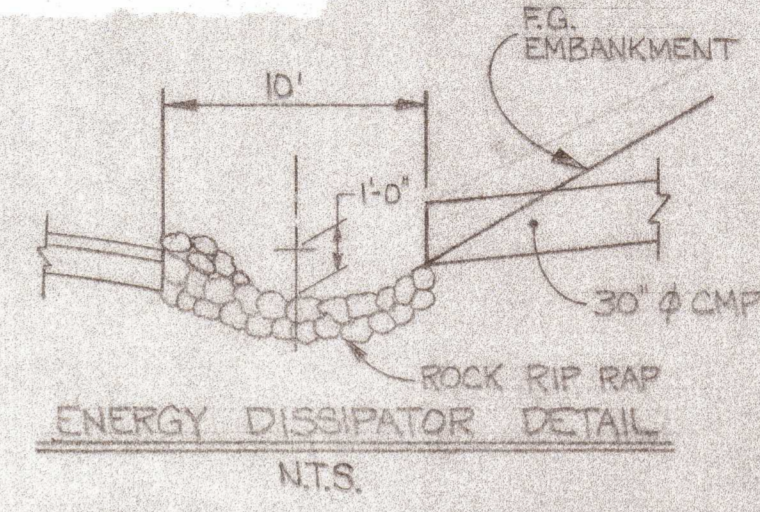
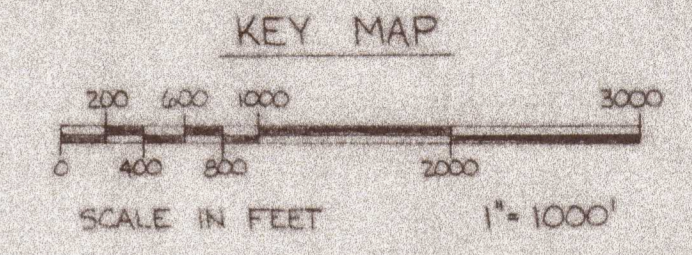
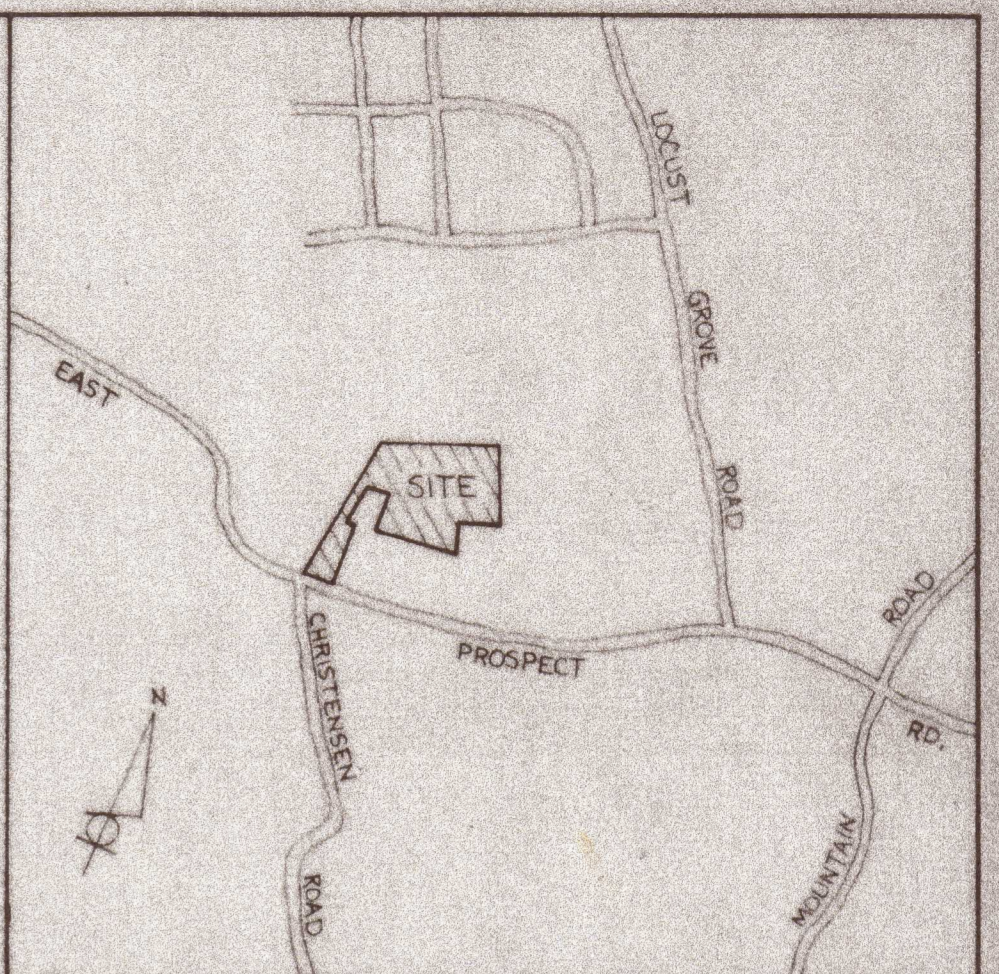
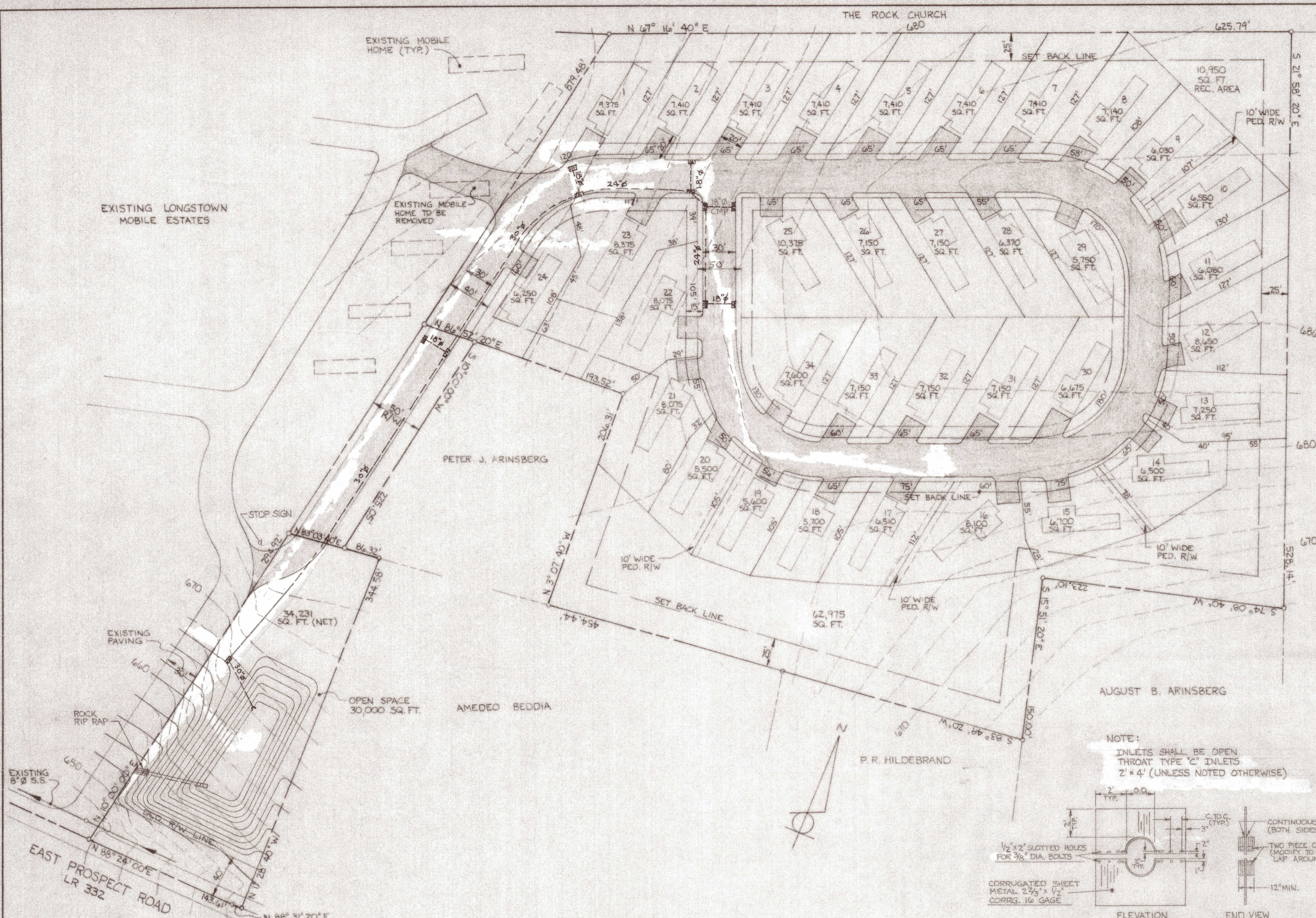

EMBANKMENT MATERIAL INCLUDING CORE  
 GRADATION - THE GRADATION OF THE EMBANKMENT MATERIAL SHALL BE IMPERVIOUS SILTY CLAY MATERIAL COMPACTED IN 6 INCH LAYERS AND SHALL CONFORM THE FOLLOWING GRADATION:  
 IMPERVIOUS - 20% FINER THAN 0.05 MM  
 STABILITY - 30% LARGER THAN 0.02 MM

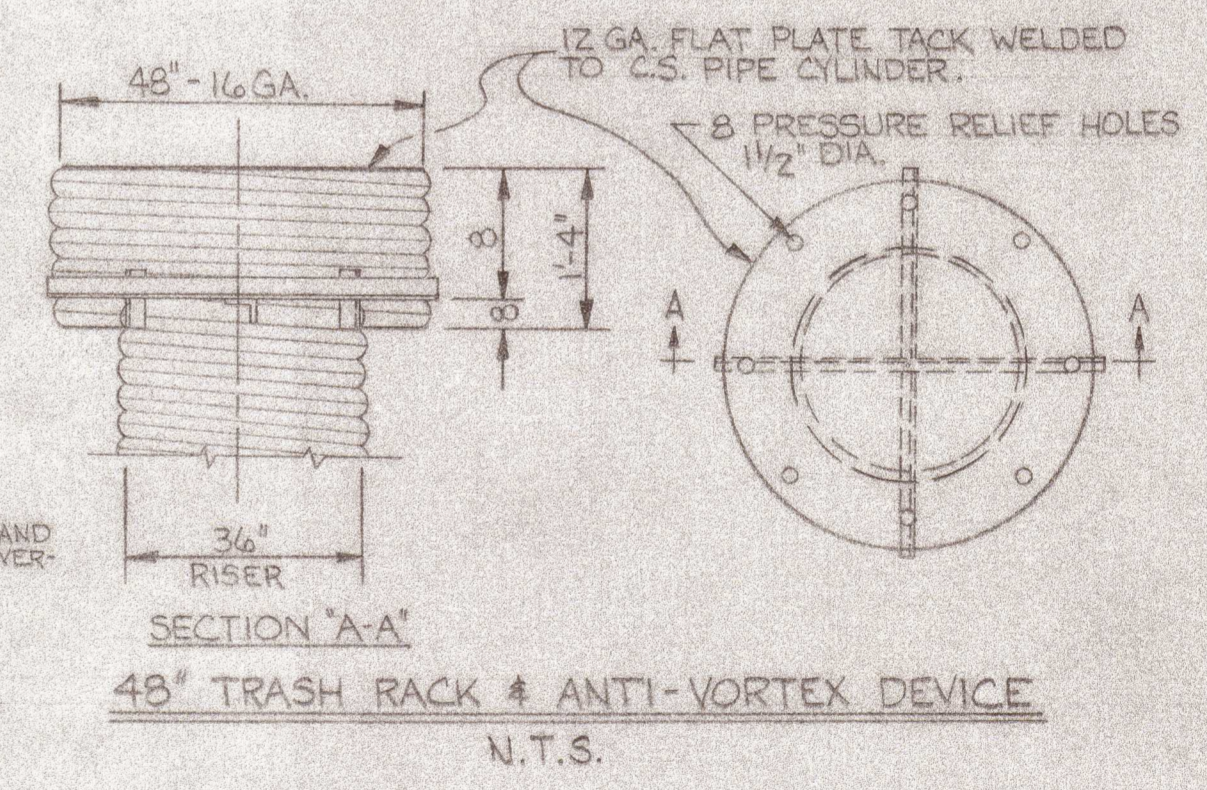
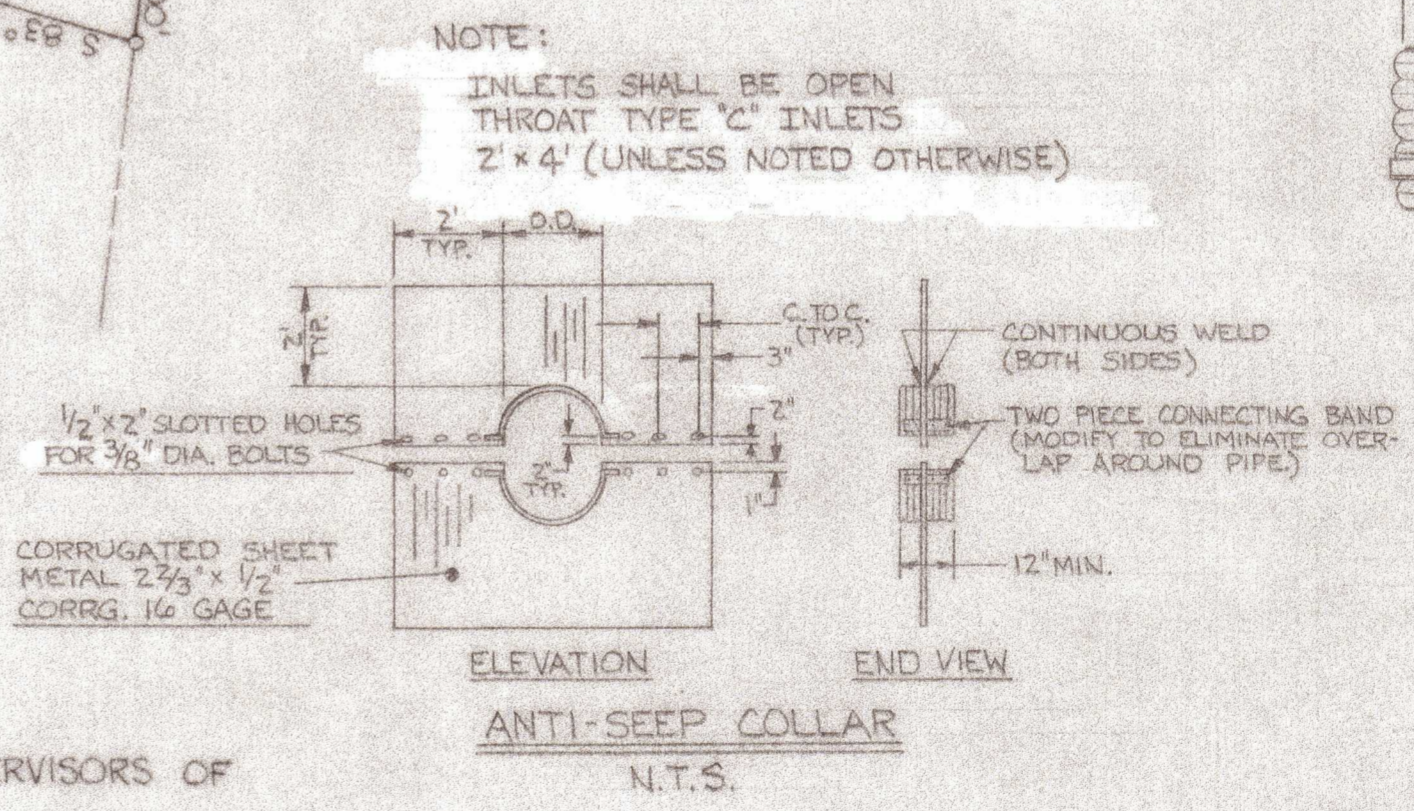

NOTE:  
 INLETS SHALL BE OPEN THROAT TYPE 'C' INLETS 2' x 4' (UNLESS NOTED OTHERWISE)

STATE OF PENNSYLVANIA COUNTY OF YORK

On this, the \_\_\_\_\_ day of \_\_\_\_\_ 19\_\_\_\_  
 before me, a Notary Public in and for said county and state, the undersigned officer, personally appeared \_\_\_\_\_  
 (or satisfactorily proven) to be the person whose name subscribed to the within plan of lots and acknowledged that he executed the same so that it may be recorded as such.  
 In Witness Whereof, I here unto set my hand and Official Seal \_\_\_\_\_  
 \_\_\_\_\_ Seal  
 \_\_\_\_\_ Title of Officer

APPROVED BY THE OWNERS  
 DATE \_\_\_\_\_  
 OWNERS ADDRESS:  
 DAVID W. SMITH  
 BRADLEY AVE.  
 DALLASTOWN, PA.

APPROVED BY THE PLANNING COMMISSION OF WINDSOR TWP.  
 DATE \_\_\_\_\_  
 \_\_\_\_\_ CHAIRMAN

APPROVED BY THE SUPERVISORS OF WINDSOR TWP.  
 DATE \_\_\_\_\_  
 \_\_\_\_\_ CHAIRMAN  
 \_\_\_\_\_ ENGINEER

I, GORDON L. BROWN, JR. A REGISTERED PROFESSIONAL LAND SURVEYOR OF THE COMMONWEALTH OF PENNSYLVANIA, DO HEREBY CERTIFY THAT THIS PLAN CORRECTLY REPRESENTS THE LOTS, LAND, AND HIGHWAYS AS SURVEYED AND PLOTTED FOR THE OWNERS OR AGENTS.

LAND SURVEYOR 166A  
 PLAN REFERENCE:  
 YORK COUNTY COURT HOUSE  
 RECORDED IN PLAN BOOK \_\_\_\_\_ PAGE \_\_\_\_\_ DATE \_\_\_\_\_

LONGSTOWN MOBILE ESTATES-ADDITION		
DAVID W. SMITH & JAMES L. MCKINSEY		
WINDSOR TWP. YORK CO. PA.		
STORM WATER MANAGEMENT PLAN		
DATE	REVISION	MARK
2-9-85		
SCALE:	1" = 50'-0"	
DRAWN BY:	MAF	
CHECKED BY:	GLB, JR.	
GORDON L. BROWN & ASSOCIATES, INC. ENGINEERS & SURVEYORS 2258 S. QUEEN ST. YORK, PA. 17402		SHEET NO. 4 OF 6 Dwg. No. L-205B





TUS Data Request Set 1

Application of The York Water Company for approval of the right to acquire certain water system assets from Longstown Mobile Estates in Windsor Township, York County  
Docket No. A-2023-3041860

A-2 Please explain how customers served by the Longstown Water System receive wastewater service and identify the entity(s) that provide wastewater service to these customers.

**RESPONDENT:**

Andrew Prosser, Senior Engineer Manager  
The York Water Company

**RESPONSE:**

The customers of Longstown MHP receive wastewater service from Windsor Township. The owners of the community receive a single bill from Windsor Township (similar to water at this time), and the owners pay the single sewer bill as a bulk customer of Windsor Township.

TUS Data Request Set 1

Application of The York Water Company for approval of the right to acquire certain water system assets from Longstown Mobile Estates in Windsor Township, York County  
Docket No. A-2023-3041860

- A-3 The Application's Page 4 specified that the Longstown Water System is owned and operated by Longstown Mobile Estates. However, Pennsylvania Department of State public records at <https://file.dos.pa.gov/search/business> appear to indicate that Longstown Mobile Estates is a fictitious name that is registered to an apparent individual named David Smith. Please identify the legal entity (i.e., the name of the individual, partnership, corporation, etc.) that owns and operates the Longstown Water System and that is selling the Longstown Water System to York Water and indicate their business or office address.

**RESPONDENT:**

Andrew Prosser, Senior Engineer Manager  
The York Water Company

**RESPONSE:**

David Smith was the owner of Longstown Mobile Estates. Mr. Smith is deceased. There is now a Residuary Trust, the David W. Smith Residuary Trust, that is 50% General Partner in the entity; Kelly Jo McKinsey is the other 50% General Partner.

TUS Data Request Set 1

Application of The York Water Company for approval of the right to acquire certain water system assets from Longstown Mobile Estates in Windsor Township, York County  
Docket No. A-2023-3041860

A-4 Please identify the water treatment plant (WTP) that will supply water to the Longstown Water System (e.g., York Water's Grantley Road WTP, etc.).

**RESPONDENT:**

Andrew Prosser, Senior Engineer Manager  
The York Water Company

**RESPONSE:**

York Water's Grantley Road WTP has been serving and will continue to serve the Longstown Water System customers.

TUS Data Request Set 1

Application of The York Water Company for approval of the right to acquire certain water system assets from Longstown Mobile Estates in Windsor Township, York County  
Docket No. A-2023-3041860

A-5 Please specify the permitted peak day capacity of the WTP that will supply water to the Longstown Water System.

**RESPONDENT:**

Andrew Prosser, Senior Engineer Manager  
The York Water Company

**RESPONSE:**

The peak day capacity of the Grantley Road WTP is 39 MGD. York Water notes that the Grantley Road WTP already provides service to the Longstown Water System, and the proposed acquisition should not affect the available capacity of the Grantley Road WTP.

TUS Data Request Set 1

Application of The York Water Company for approval of the right to acquire certain water system assets from Longstown Mobile Estates in Windsor Township, York County  
Docket No. A-2023-3041860

A-6 Please quantify York Water WTP's peak and average daily production for the 2022 calendar year.

**RESPONDENT:**

Andrew Prosser, Senior Engineer Manager  
The York Water Company

**RESPONSE:**

The Grantley Road WTP peak production was 25.2 MGD, and its average production was 21.5 MGD in 2022. These production numbers reflect and include 2022 service to the Longstown MHP. This acquisition should not result in an increase to the average production nor the peak production at Grantley Road WTP.

TUS Data Request Set 1

Application of The York Water Company for approval of the right to acquire certain water system assets from Longstown Mobile Estates in Windsor Township, York County  
Docket No. A-2023-3041860

A-7 Please provide the average monthly water usage for Longstown Water System customers for the 2022 calendar year.

**RESPONDENT:**

Andrew Prosser, Senior Engineer Manager  
The York Water Company

**RESPONSE:**

The Longstown Water System's average monthly water usage in 2022 was 403,475 gallons per month.

TUS Data Request Set 1

Application of The York Water Company for approval of the right to acquire certain water system assets from Longstown Mobile Estates in Windsor Township, York County  
Docket No. A-2023-3041860

A-8 Please quantify the number of customer connections, by customer class, currently connected to the Longstown Water System.

**RESPONDENT:**

Andrew Prosser, Senior Engineer Manager  
The York Water Company

**RESPONSE:**

According to the Seller, there are 88 individual residential customers connected to the Longstown Water System and no other classes of customers connected to the Longstown Water System.

TUS Data Request Set 1

Application of The York Water Company for approval of the right to acquire certain water system assets from Longstown Mobile Estates in Windsor Township, York County  
Docket No. A-2023-3041860

A-9 Please quantify an estimate of the number of connections, by customer class, anticipated to connect to the Longstown Water System within the next five years.

**RESPONDENT:**

Andrew Prosser, Senior Engineer Manager  
The York Water Company

**RESPONSE:**

No additional connections are anticipated within the next five years.

TUS Data Request Set 1

Application of The York Water Company for approval of the right to acquire certain water system assets from Longstown Mobile Estates in Windsor Township, York County  
Docket No. A-2023-3041860

A-10 Please quantify the number of lots included in the Longstown MHP.

**RESPONDENT:**

Andrew Prosser, Senior Engineer Manager  
The York Water Company

**RESPONSE:**

88 lots.

TUS Data Request Set 1

Application of The York Water Company for approval of the right to acquire certain water system assets from Longstown Mobile Estates in Windsor Township, York County  
Docket No. A-2023-3041860

A-11 Please confirm that, upon closing of the transaction and completion of the Proposed Facilities, York Water will be able to provide adequate water supply, treatment, storage, and distribution capacity to meet present and future customer needs.

**RESPONDENT:**

Andrew Prosser, Senior Engineer Manager  
The York Water Company

**RESPONSE:**

Confirmed. York Water already provides bulk water service to the Longstown Water System and will continue to have adequate water supply, treatment, storage, and distribution capacity to meet present and future customer needs.

TUS Data Request Set 1

Application of The York Water Company for approval of the right to acquire certain water system assets from Longstown Mobile Estates in Windsor Township, York County  
Docket No. A-2023-3041860

A-12 Please confirm that York Water and the Longstown MHP are not affiliated and that all negotiations were conducted at arm's length.

**RESPONDENT:**

Andrew Prosser, Senior Engineer Manager  
The York Water Company

**RESPONSE:**

York Water and the Longstown MHP are not affiliated, and all negotiations were conducted at arm's length.

TUS Data Request Set 1

Application of The York Water Company for approval of the right to acquire certain water system assets from Longstown Mobile Estates in Windsor Township, York County  
Docket No. A-2023-3041860

A-13 Please provide York Water’s tentative journal entries, by major plant account, for booking the purchase of Longstown’s assets in accordance with the National Association of Regulatory Utility Commissioners Uniform System of Accounts applicable to York Water. These journal entries should be similar in form to the tentative journal entries provided on Page 10 of York Water’s Application at Docket Nos. A-2023-3038862 and A-2023-3038864 under “Record Purchase of System”.

**RESPONDENT:**

Matthew Poff, Chief Financial Officer  
The York Water Company

**RESPONSE:**

1. Record Purchase of System

Account No.	Account Description	Debit	Credit
105	Construction Work in Process	\$12,001	
131	Cash		\$12,001

2. Close Project to Utility Plant

Account No.	Account Description	Debit	Credit
101	Utility Plant in Service	\$30,945	
108	Accumulated Depreciation		\$18,566
114	Utility Plant Acquisition Adj.		\$378
105	Construction Work in Process (Purchase price + other acquisition costs)		\$12,001

TUS Data Request Set 1

Application of The York Water Company for approval of the right to acquire certain water system assets from Longstown Mobile Estates in Windsor Township, York County  
Docket No. A-2023-3041860

A-14 Please provide an estimate of York Water's cost to acquire the Longstown Water System, including incidental expenses properly includible in utility plant.

**RESPONDENT:**

Andrew Prosser, Senior Engineer Manager  
The York Water Company

**RESPONSE:**

Costs to acquire the Longstown Water System include purchase price and the costs to install residential meters. Such costs are:

- Purchase price = \$1
- 88 x 5/8" meters for each residential unit (\$80/meter) = \$7,040
- 88 x meter pits (\$200/pit) = \$17,600

Both the meter costs and the meter pit costs would be recorded to plant account 10133440 in York Water's Annual Report to the Pennsylvania Public Utility Commission.

TUS Data Request Set 1

Application of The York Water Company for approval of the right to acquire certain water system assets from Longstown Mobile Estates in Windsor Township, York County  
Docket No. A-2023-3041860

A-15 Please identify the anticipated closing time frame for the proposed transaction after Commission approval of the Application.

**RESPONDENT:**

Andrew Prosser, Senior Engineer Manager  
The York Water Company

**RESPONSE:**

This transaction could close within 30 days of Commission approval. York Water would install meters and meter pits within 18 months after closing.

TUS Data Request Set 1

Application of The York Water Company for approval of the right to acquire certain water system assets from Longstown Mobile Estates in Windsor Township, York County  
Docket No. A-2023-3041860

A-16 Please confirm whether York Water’s effective water tariff requires York Water to exclude customers served by the Longstown Water System and Longstown Water System investments, expenses, and revenues from York Water’s distribution system improvement charge (DSIC) until York Water receives Commission approval of a new or modified long-term infrastructure improvement plan that incorporates DSIC eligible property information for the Longstown Water System.

**RESPONDENT:**

Andrew Prosser, Senior Engineer Manager  
The York Water Company

**RESPONSE:**

York Water’s effective tariff does not “exclude customers served by the Longstown Water System and Longstown Water System investments, expenses, and revenues from York Water’s distribution system improvement charge until York Water receives Commission approval of a new or modified long-term infrastructure improvement plan that incorporates DSIC eligible property information for the Longstown Water System.”

However, if the pending Application is approved, York Water’s compliance tariff filing will include language excluding the Longstown Water System customers and the Longstown System water distribution system investments, expenses, and revenues from York Water’s DSIC until York Water receives Commission approval of a new or modified LTIIP that incorporates DSIC eligible property information for the Longstown Water System. York Water notes that this exclusion would be limited to the customers and water distribution system investments, expenses, and revenues specific to the Longstown Water System, *i.e.*, beyond the point of interconnection through which Longstown Water System currently receives bulk water service from York Water.

TUS Data Request Set 1

Application of The York Water Company for approval of the right to acquire certain water system assets from Longstown Mobile Estates in Windsor Township, York County  
Docket No. A-2023-3041860

A-17 Please clarify whether any permits, easements, or rights-of-way are required to construct, operate, and maintain the Proposed Facilities. If so, identify the necessary permits, easements, and rights of way, their estimated costs, and the entity responsible for obtaining each applicable permit, easement, or right-of-way.

**RESPONDENT:**

Andrew Prosser, Senior Engineer Manager  
The York Water Company

**RESPONSE:**

No new permits, easements, or rights-of-way are required for York Water to provide service to the Longstown Water System customers.

## TUS Data Request Set 1

Application of The York Water Company for approval of the right to acquire certain water system assets from Longstown Mobile Estates in Windsor Township, York County  
Docket No. A-2023-3041860

A-18 Please explain how Application approval would benefit York Water's existing customers.

### **RESPONDENT:**

Andrew Prosser, Senior Engineer Manager  
The York Water Company

### **RESPONSE:**

Approval of the proposed Application will benefit the Company's existing water customers because by expanding the Company's customer base, York Water's fixed water costs will be spread over a greater number of customers. Furthermore, the revenues received from these new customers can help pay for system improvements elsewhere on the Company's system. York Water also maintains that the Commission should take other considerations into account when determining whether the Application is necessary and proper for the service, accommodation, convenience, and safety of the public, including how:

- (a) York Water currently provides water service in Windsor Township and, therefore, is familiar with and operates in this community;
- (b) York Water already provides bulk water service to these customers through a single point of connection with Longstown Mobile Estates, and the acquisition of the distribution system provides efficiencies of scale and a seamless single utility provider service to the customers;
- (c) York Water and Longstown Mobile Estates have an executed contract for the purchase of the Longstown Mobile Estates water distribution system and the transfer of specified assets to York Water;
- (d) No other public utility is authorized to provide water distribution service to Longstown Mobile Estates as it is within York Water's certificated territory;
- (e) York Water's existing facilities are already connected and are already providing the required supply of water to these dwellings; and
- (f) York Water has access to adequate reserves of water within the York County area and has the ability to comply with the requirements of both the United States and Pennsylvania Safe Drinking Water Acts, the public health protections and benefits of which are thereby assured to the distribution system customers.
- (g) The Commission encourages utilities, such as York Water, to acquire small water systems, such as the Longstown Water System. *See* 52 Pa. Code § 69.721.

TUS Data Request Set 1

Application of The York Water Company for approval of the right to acquire certain water system assets from Longstown Mobile Estates in Windsor Township, York County  
Docket No. A-2023-3041860

A-19 Please state whether Windsor Township has a mandatory connection ordinance for water service.

**RESPONDENT:**

Andrew Prosser, Senior Engineer Manager  
The York Water Company

**RESPONSE:**

This request is irrelevant to the instant Application because York Water is already certificated to serve Windsor Township. The Application does not involve expanding the Company's certificated service territory to include a new area, where customers in that area could be forced to connect to York Water's distribution system if there were a mandatory connection ordinance in place. Moreover, York Water's water distribution main serving the Longstown Water System is already in place, and Longstown MHP is built out.

## VERIFICATION

I, Andrew Prosser, Senior Engineer Manager of The York Water Company, hereby state that the facts above set forth are true and correct to the best of my knowledge, information and belief and that I expect to be able to prove the same at a hearing held in this matter. I understand that the statements herein are made subject to the penalties of 18 Pa. C.S. § 4904 (relating to unsworn falsification to authorities).

Date: October 27, 2023

DocuSigned by:  
*Andrew Prosser*  
671F0440C021440...  
Andrew Prosser

## VERIFICATION

I, Matthew E. Poff, Chief Financial Officer of The York Water Company, hereby state that the facts above set forth are true and correct to the best of my knowledge, information and belief and that I expect to be able to prove the same at a hearing held in this matter. I understand that the statements herein are made subject to the penalties of 18 Pa. C.S. § 4904 (relating to unsworn falsification to authorities).

Date: October 27, 2023

DocuSigned by:  
*Matthew Poff*  
BEF075C937D84DF...  
Matthew E. Poff