

**Michael J. Shafer**  
Senior Counsel

**PPL**  
Two North Ninth Street  
Allentown, PA 18101-1179  
Tel. 610.774.2599 Fax 610.774.4102  
MJShafer@pplweb.com



**E-File**

February 20, 2024

Rosemary Chiavetta, Secretary  
Pennsylvania Public Utility Commission  
Commonwealth Keystone Building  
400 North Street, 2<sup>nd</sup> Floor North  
Harrisburg, PA 17120-3265

**Re: PPL Electric Utilities Corporation, License Agreement  
SEDA-COG Joint Rail Authority, City of Sunbury,  
Northumberland County, Pennsylvania**

---

Dear Secretary Chiavetta:

Enclosed for filing on behalf of PPL Electric Utilities Corporation ("PPL Electric") is a License Agreement between PPL Electric and the SEDA-COG Joint Rail Authority, City of Sunbury, Northumberland County, Pennsylvania.

This agreement is being filed pursuant to 66 Pa. C.S.A. § 507.

Pursuant to 52 Pa. Code § 1.11, the enclosed document is to be deemed filed on February 20, 2024, which is the date it was filed electronically using the Commission's E-filing system.

If you have any questions, please do not hesitate to contact me.

Respectfully submitted,

A handwritten signature in blue ink, appearing to read "Michael J. Shafer", is written over a light blue horizontal line.

Michael J. Shafer

Enclosure

SEDA-COG JRA License #08-166.0

**SEDA-COG JOINT RAIL AUTHORITY**

**LICENSE AGREEMENT**

THIS LICENSE AGREEMENT (the “License Agreement”) is made as of the 13<sup>th</sup> day of December, 2023 (the “Effective Date”), by and between **SEDA-COG JOINT RAIL AUTHORITY**, a Pennsylvania municipal authority with its principal office address at 201 Furnace Road, Lewisburg, Pennsylvania 17837 (the “Authority”)

-AND-

**PPL ELECTRIC UTILITIES CORPORATION**, a Pennsylvania corporation with its principal place of business at 2 N. Ninth Street (GENN4), Allentown, PA 18101-1179 (the “Licensee”)

**BACKGROUND**

A. The Authority owns certain real property and railroad lines located in the City of Sunbury, Northumberland County, Pennsylvania (the “Property”).

B. The Authority has agreed to grant a license to Licensee (the “License”) over the Property for the purpose of accessing an existing Authority right-of-way for the replacement, maintenance and repair of aerial cables (the “Facilities”), within the portion of the Property more specifically described and depicted on Exhibit “A” attached hereto and made a part hereof (the “Licensed Use”).

C. The Authority and Licensee desire by this License Agreement to provide for the License described above.

**NOW THEREFORE**, in consideration of the foregoing background recitals, and intending to be legally bound, the parties agree as follows:

1. **Recitals.** The above recitals are incorporated into and made a part of this Agreement.

2. **Grant of License.** The Authority does hereby grant to Licensee, its successors and assigns, to the extent the title of the Authority so permits, the License for the space and dimensions required for use and occupation by Licensee for the Licensed Use. The location of the Facilities shall be exclusively within the license area (the “License Area”) described on Exhibit “A” attached hereto. Unless approved in writing by the Authority, Licensee’s use of the Property under this License Agreement shall be for no purposes other than the Licensed Use. If the Property is used by Licensee for any purpose other than the Licensed Use, the License shall be automatically terminated, and all of the right, title and interest of Licensee (and Licensee’s successors or assigns) in and to the Property shall become null and void, and the Property shall absolutely revert to and revest in the Authority as fully and completely as if this instrument had

## SEDA-COG JRA License #08-166.0

not been executed. The grant of the License is subject to any and all previously granted easements, rights-of-way, licenses and conveyances, recorded or unrecorded. It is Licensee's sole responsibility to determine the existence of any rights, uses or installations conflicting with Licensee's use of the Property hereunder. Licensee agrees to not interfere with any use in the License Area by any other party under a previous grant. Licensee understands and agrees that the Authority makes no representations concerning the Property. To the extent that this grant of License may encroach on lands not owned or controlled by the Authority, Licensee assumes all responsibility for any such encroachment.

3. **Use of the Licensed Area.** Licensee agrees that this instrument is only a grant of license for the purposes herein contained, and for only so long as provided in this License Agreement. Nothing contained herein shall be construed to grant to Licensee the fee title to the portions of the Authority's Property, but title to the land used for the Facilities shall remain vested in the Authority, subject to the rights herein granted. Licensee shall not use or permit the License Area to be used in any way or for any other purposes other than the Licensed Use. In addition, Licensee acknowledges and agrees that the License granted hereunder shall be subject to any and all rights granted by the Authority to Shamokin Valley Railroad Company, as rail operating company, or its successors or assigns, or any other railroad company under agreement with the Authority to conduct rail operations on any railroad tracks located on the Property (the "Railroad Operator"). The Authority makes no representation or warranty whatsoever to Licensee regarding the strength or validity of the License granted hereunder, and Licensee, and any parties claiming by, under, or through it, hereby expressly releases the Authority, the Railroad Operator and their respective directors, members, officers, employees, agents and representatives from any liability that may arise from any claims of any third party or parties based on the grant of this License, including any claims asserting paramount or superior rights to, or conflicting rights with, Licensee's License. Licensee shall indemnify and hold harmless Authority, the Railroad Operator and their respective directors, members, officers, employees, agents and representatives, under Section 9 hereof against any such claims.

4. **Construction, Alteration and Maintenance.**

a. Unless provided otherwise herein, Licensee shall be solely responsible for construction, installation, alteration, maintenance and repair of the Facilities. The Authority shall not be responsible for any cost or expense whatsoever relating to the Facilities or this License. All work to be performed by Licensee on the License Area shall be performed in a good and workmanlike manner, shall be approved in advance by the Authority, and shall not interfere with the operations of the Authority, the Railroad Operator, or their employees, agents, contractors, subcontractors, licensees, and invitees.

b. Licensee shall give the Authority and its Railroad Operator at least seven (7) days advance written notice prior to commencing construction or alteration of the Facilities in the License Area. Licensee shall notify the Railroad Operator promptly of any unsafe conditions or other matters affecting operations on the License Area.

SEDA-COG JRA License #08-166.0

c. If required by the Authority, Licensee shall provide adequate drainage facilities on the License Area for the prevention of flooding or other water damage to the Property.

d. Licensee shall, at its sole cost and expense, when performing any work on the License Area, furnish flagmen, watchmen, and inspectors, and take such other safety measures as reasonably necessary to keep persons and property a safe distance from the railroad tracks of the Authority. The Authority reserves the right to approve such flagmen, watchmen, or inspectors required under this Section and may require that such flagmen, watchmen, or inspectors be provided by the Railroad Operator operating on the tracks of the Authority. If at any time the Authority should deem flagmen, watchmen, or inspectors desirable or necessary during the course of installation, alteration, maintenance, repair, relocation, or removal of the Facilities, the Authority shall have the right to place such flagmen, watchmen, or inspectors on the Property, at Licensee's cost and expense.

e. Licensee shall at all times during the Term of this License Agreement keep the Facilities in good repair and safe condition (including removing any accumulation of dirt, ice, snow and debris).

f. The Authority shall have the right to enter and inspect the Property and the Facilities at any time, with advance notice to Licensee.

g. If reasonably necessary to protect and safeguard the tracks and any persons or property on the Property, Licensee shall, upon request of the Authority, repair the Facilities, at Licensee's sole expense. In addition, the Authority may require Licensee to repair, renew, or alter the Facilities in connection with the addition, removal, change in grade or location of, or repair of the railroad tracks or facilities on the Property at Licensee's sole cost and expense. If Licensee fails to comply with any request of the Authority for any repair, renewal, or alteration within thirty (30) days after notice from the Authority, or if the Authority otherwise deems that such repair, renewal, alteration or removal reasonably requires immediate action, the Authority may so repair, renew, alter or remove the Facilities used in connection therewith.

h. Licensee shall comply with all federal, state, and local laws, rules, regulations, ordinances and court orders affecting the Property and the Facilities. Licensee shall not (i) do anything, nor bring or keep anything in or around the Property, that will increase the risk of fire or other loss, create a dangerous condition on the Property (unless safeguarded as required by law), or constitute a public or private nuisance; (ii) commit or suffer any waste upon or about the Property; or (iii) do anything that might reasonably tend to impair the Authority's rights in the Property.

i. Licensee shall not use the Property for the disposal, emission, storage, treatment, release, transporting, processing or other handling of waste, contamination, PCB's or other toxic or Hazardous Substances, without the prior written consent of the Authority. "Hazardous Substances" shall mean any substances regulated under the Comprehensive Environmental Response Compensation and Liability Act of 1980 ("CERCLA"), the Resources Conservation and Recovery Act of 1976, the federal Clean Water Act, the federal Clean Air Act,

## SEDA-COG JRA License #08-166.0

the Pennsylvania Solid Waste Management Act, or any other federal, state or local statute, ordinance, regulation, rule, standards or requirements of common law relating to protections of health and the environment (collectively, "Environmental Laws"). Licensee shall comply with all applicable federal, state and local Environmental Laws while on the Property. If Licensee receives notice from any governmental authority that reasonably relates to the Property, Licensee shall immediately notify the Authority and provide the Authority with a copy of such notice and all other written correspondence received from such governmental authority.

j. At its sole cost and expense, Licensee shall take or cause to be taken such safety measures in the reasonable opinion of Authority necessary to avoid injury to persons or damage to property on the Property, including erecting and maintaining appropriate grade crossing signs satisfactory to the Authority.

5. **Term.** The term of the License (the "Term") shall commence on the Effective Date and shall continue until terminated (i) by Licensee by written notice to the Authority at any time or (ii) by the Authority in accordance with Section 15 below.

6. **License Fee.** The annual license fee (the "License Fee") charged for this License Agreement shall be **Five Hundred and 0/100 (\$500.00) Dollars**. Licensee shall be solely responsible for any and all costs associated with or relating to the Facilities and the License, including any costs associated with the preparation of this License Agreement, including a one-time license preparation fee in the amount of **Eight Hundred Eighty and 0/100 (\$880.00) Dollars** assessed to cover application preparation, legal review and recording fees. Payment of the License Fee shall be made in the manner set forth in the invoice from the Authority. In the event the Authority incurs any expense relating to the Facilities or this License Agreement for which Licensee has assumed responsibility under this License Agreement, the Authority shall deliver an invoice for such expense incurred and Licensee shall reimburse the Authority for such expense no later than thirty (30) days after the date of such invoice. Any License Fee due hereunder may be adjusted for inflation in each subsequent year of the Term based on the increase, if any, in the Consumer Price Index for the adjustment period commencing on the Effective Date and ending on the date of the other period that may be provided for calculating the adjustment. The Consumer Price Index for purposes of this License shall be the Consumer Price Index for All Urban Consumers (CPI-U), All Items Less Food and Energy (1982-84 = 100) published by the Bureau of Labor Statistics, United States Department of Labor (the "Index"). If the Index ceases to be published, then the License Fee adjustment calculations shall be based on the closest successor index published by the United States Department of Labor. In no event shall there be any decrease to the License Fee.

7. **Casualty.** If any portion of the Property is damaged or destroyed by fire or other casualty caused by any party other than Licensee (or its agents, representatives, employees, and/or contractors), then Licensee shall give notice thereof to the Authority, and may, at its option (1) repair, restore, rebuild, or replace the Facilities to the condition they were in prior to such damage or destruction, or (2) terminate this License Agreement by written notice to Authority. In such event, Licensee shall be entitled to retain all insurance proceeds that relate to damage to the Facilities and its personal property, trade fixtures, or equipment on the Property.

SEDA-COG JRA License #08-166.0

Any damage or destruction to the Property caused by Licensee or its agents, representatives, employees, and/or contractors shall be considered a breach of this License Agreement.

8. **Eminent Domain/Condemnation.** If all or any part of the License Area is taken by eminent domain, condemnation, or other action pursuant to applicable law, and if such taking renders the License Area wholly unusable by Licensee for the use permitted under this License, then the License shall terminate as of the date of such taking and the Authority shall be subject to no liability hereunder for such taking.

9. **Indemnification.**

a. Licensee shall pay, protect, indemnify, defend, save and hold harmless the Authority and its directors, members, officers, employees, agents and representatives, and Authority's contractors, subcontractors and their respective directors, owners, officers, and employees (each, an "Indemnitee") from and against any and all liabilities, losses, damages (including punitive damages), penalties, costs (including attorneys' fees and costs), causes of action, suits, claims, demands or judgments of any nature whatsoever, howsoever caused, without regard to the form of action and whether based on strict liability, negligence or any other theory of recovery at law or in equity arising from (i) any matter pertaining to use, non-use, occupancy, operation, condition, design, construction, maintenance, repair or restoration of the Property, (ii) any casualty in any manner arising from the Licensee's use of the License or the Property whether or not any Indemnitee has or should have knowledge or notice of any defect or condition causing or contributing to such casualty, (iii) any violation of Licensee of any provision of this License, any contract or agreement to which Licensee is a party, or any requirement of any federal, state, or local law, regulation, rule, ordinance or court order, or (iv) any alleged, threatened or actual violation of Environmental Laws, including (A) liability for response costs and for costs of removal and remedial action incurred by the federal government, any state or local governmental unit or any other person or entity, or damages from injury to or destruction or loss of natural resources, including the reasonable costs of assessing such injury, destruction or loss, incurred pursuant to Section 107 of CERCLA, or any successor section or act or provision of any similar state or local law, (B) liability for costs and expenses of abatement, correction or clean-up, fines, damages, response costs or penalties which arise from the provisions of any other Environmental Laws, and (C) liability for personal injury or property damage arising from any statutory or common law tort theory, including damages assessed for the maintenance of a public or private nuisance or for carrying on of a dangerous activity.

b. In case any action or proceeding is brought against any Indemnitee by reason of any such claim (i) Licensee may retain its own counsel and defend such action (it being understood that Authority may employ counsel of its choice to monitor the defense of any such action, the cost of which shall be paid by Licensee) and (ii) such Indemnitee shall notify Licensee to resist or defend such action or proceeding by retaining counsel reasonably satisfactory to such Indemnitee, and such Indemnitee will cooperate and assist in the defense of such action or proceeding if reasonably requested to do so by Licensee.

c. The obligations of Licensee under this Section shall survive the termination or expiration of this License.

## SEDA-COG JRA License #08-166.0

10. **Limitation of Liability.** Licensee understands that railroad operations at or near the License Area involve some risk, and Licensee, as part of the consideration for the License, and with full knowledge and appreciation of such risk, hereby assumes all risk of damage to property or injury to persons in or about the License Area and waives all such claims against the Authority and the Railroad Operator and their directors, members, officers, employees, agents and representatives on account of the same, including claims for consequential or indirect damages, except to the extent caused by the gross negligence or willful misconduct of the Authority, the Railroad Operator, or its or their respective employees or contractors. Furthermore, the Authority shall retain any and all immunities available to it under federal, state or local law, it being expressly understood that the Authority does not waive any such immunities available to it by entering into this License Agreement.

11. **Restoration of Property.** Upon the expiration or termination of this License Agreement, Licensee shall, at its sole cost and expense, remove from the Property all of its equipment, inventory or other personal property. Licensee shall also remove all waste, rubbish and debris in the License Area, and leave the same in clean condition, normal wear and tear and damage by casualty and condemnation excepted. Upon completion of Licensee's restoration of the License Area, the Authority shall inspect the License Area and notify Licensee of any failure to comply with the provisions of this section. Should Licensee fail, neglect or refuse to have completed all of the foregoing by the expiration or termination of this License, then the Authority may (i) remove the items abandoned by Licensee and deliver a written demand upon Licensee for reimbursement of any reasonable, out-of-pocket cost or expense incurred by the Authority in connection with such removal, which shall be paid by Licensee within thirty (30) days of such demand, (ii) sell any of the property left on the Property and retain the proceeds of such sale, or (iii) retain and use such property for any purpose whatsoever, free and clear of any right, title, or interest therein of Licensee or of any third party claiming through or under Licensee and without any liability whatsoever to Licensee or such third party.

12. **Liens and Taxes.** Licensee covenants and agrees to indemnify, defend, and hold the Authority harmless from and against any liens, assessments, taxes, or charges of any kind made against the Authority or any of its Property by reason of this License Agreement or the Licensed Use, and Licensee covenants and agrees to pay to the Authority, within thirty (30) days of the date of notice from the Authority, the full amount of any such liens, assessments, taxes, or charges rendered against the Authority or any of its Property, including penalties, interest, late fees, and the costs to remove or bond any lien, assessment, tax, or charge. Failure of Licensee to comply with the terms of this Section shall be a breach of this License Agreement.

13. **Insurance.** Licensee shall obtain and maintain throughout the Term of this License Agreement (i) commercial general liability insurance (written on an occurrence basis) in an aggregate amount of not less than Five Million (\$5,000,000.00) Dollars single limit per occurrence and Ten Million (\$10,000,000) Dollars general aggregate, including contractual liability coverage for any operations within fifty (50') feet of the railroad and insuring the obligations assumed by the Licensee in this Agreement, premises and operations coverage, products and ongoing completed operations coverage, broad form property damage coverage, independent contractors coverage, and an endorsement for personal injury, (ii) business interruption insurance in a minimum amount typically carried by prudent grantees engaged in

## SEDA-COG JRA License #08-166.0

similar operations, but in no event less than the License Fee then in effect during any year of the Term of this License Agreement, (iii) all-risk property insurance in an amount not less than that required to replace Licensee's equipment and personal property, (iv) worker's compensation insurance (or Federal Employers Liability Act coverage if applicable) at minimum limits as defined by the law of the jurisdiction in which the Property is located (as the same may be amended from time to time), and (v) employer's liability insurance in an aggregate amount not less than Two Million Dollars (\$2,000,000.00) for each accident, or in such other amounts as the Authority and Licensee may agree, and (vi) railroad accident pollution liability coverage. All insurance required hereunder shall be in with companies rated A-, VII or better by AM Best, and the Authority may waive any such insurance requirements in writing. Licensee agrees that Authority and the Railroad Operator, and their successors and assigns, shall each be named as an additional insured and/or certificate holder, as they may require in writing to Licensee and on insurance company specific forms reasonable acceptable to the Authority and the Railroad Operator, on a primary and non-contributory basis on all policies of insurance required to be maintained by Licensee under this Agreement. Upon execution of this Agreement and upon any reasonable request by the Authority thereafter, Licensee shall give the Authority certificates of insurance evidencing all coverage obtained as required by this Agreement, naming the Authority, the Railroad Operator, and their successors and assigns as additional insured and/or certificate holder as required herein. The provision of all insurance under this Section shall not be deemed a limitation on the liability of Licensee as provided in this Agreement, but shall be additional security. All such policies shall provide a waiver of subrogation in favor of the Authority and Railroad Operator, and their respective members, directors, officers, owners, employees, agents and representatives. If requested by the Authority, Licensee shall furnish additional insurance coverage against such other hazards as the Authority may reasonably require, including coverage for any liability described in Section 9 above (to the extent not already covered by another policy of insurance). Proof must also be given by Licensee to Authority that each of the policies provided for in this Section shall include standard language to require that such policy shall not be cancelled or altered without ten (10) days prior written notice to the Authority. Such certificates shall state that notice of cancellation will be given in accordance with policy provisions.

14. **Permits.** Licensee shall be solely responsible for acquiring all permits, licenses, and any other third party approvals necessary for Licensee's use of the Property under this License Agreement.

15. **Default; Remedies.** Licensee shall be in default if Licensee breaches or fails to observe or perform any term or obligation required by this License Agreement. In the event of a default by Licensee, the Authority shall provide written notice to Licensee of the default and a period of thirty (30) business days to cure the default. If Licensee fails to cure the default within such thirty (30) day cure period, the Authority shall have all rights and remedies available to it at law and in equity, including the right to immediately terminate this License Agreement and/or Licensee's right to use the Licensed Premises by written notice to Licensee, and the right to remove the Facilities at Licensee's sole cost and expense. In the event of a default, Licensee shall be responsible for paying any reasonable attorney's fees and court costs incurred by the Authority in connection with the enforcement of its rights under this License Agreement.

SEDA-COG JRA License #08-166.0

16. **Choice of Law; Venue.** This License Agreement shall be governed, interpreted, construed, and regulated by the laws of the Commonwealth of Pennsylvania. Any litigation concerning this License Agreement shall be conducted in the courts located in the County and Commonwealth in which the Property is situated, and the parties hereto agree to the venue and personal jurisdiction of such courts.

17. **Notice.** Any notice or demand made pursuant to this License Agreement shall be made by personal hand delivery; by certified mail, return receipt requested, in a sealed envelope, postage prepaid; or by overnight courier and addressed as shown below:

Licensee: PPL Electric Utilities  
2 N. Ninth Street (GENN4)  
Allentown, PA 18101-1179  
Attn: Transmission ROW & RE Supervisor

Authority: SEDA-COG Joint Rail Authority  
201 Furnace Road  
Lewisburg, PA 17837  
Attn: Executive Director

Any such notice or demand shall be deemed to have been given or made at the time it is hand delivered, received in the United States Mail by the addressee, or delivered by overnight courier. Either party may by written notice to the other party designate any other address and/or addressee for this purpose.

18. **Assignment; Sublicense.** Licensee shall not assign this License or the rights, benefits, duties and obligations under this License Agreement without the prior written consent of the Authority, such consent not to be unreasonably withheld. Authority is expressly given the right to assign any or all of its interest under the terms of this License Agreement to any entity or individual who agrees in writing to be bound by the terms of this License Agreement. Licensee may not sublicense the License or any part of the License Area without the prior consent of the Authority.

19. **Binding on Successors and Assigns.** This License Agreement shall extend to and bind the successors and assigns of the parties hereto.

20. **Miscellaneous.** The parties hereto declare that they have read and understand each and every term, condition and covenant contained in this License Agreement and in any document incorporated by reference. This License Agreement includes the entire agreement between the parties relating hereto and supersedes all prior or contemporaneous negotiations, commitments, representation, writings and/or oral understandings or agreements. Accordingly, the parties expressly acknowledge that any prior agreement or understanding between the parties and/or their predecessors-in-interest, to the extent such agreement or understanding concerns the License Area, the Licensed Use, or the Facilities, is hereby replaced and superseded by this License Agreement to the extent such prior agreement conflicts with the subject matter of this License Agreement. The parties signed this License Agreement for the consideration herein

SEDA-COG JRA License #08-166.0

expressed. Any addition to, variation or modification of this License Agreement shall be void and ineffective unless in writing signed by the parties hereto. No failure of Authority to insist upon the strict performance of any condition or covenant of this License Agreement or to exercise any right or remedy consequent upon a default hereunder shall constitute a waiver of any such condition, covenant or default. Licensee hereby agrees to pay all costs and fees in conjunction with the filing or recording of this instrument and any plans in conjunction therewith in or with any public place or with any public agency or subdivision. This License Agreement may be executed in one or more counterparts, each of which shall be deemed an original but all of which together shall constitute one and the same instrument. A signed copy of this License Agreement delivered by facsimile, electronic mail (e.g., with a .pdf attachment), or other means of electronic transmission shall be deemed to have the same effect as the delivery of an original signed copy of this Agreement to the extent permitted by law.

a. This Agreement is between a public utility and a municipal corporation and is therefore subject to Pennsylvania Public Utility Commission (“PUC”) review pursuant to 66 Pa.C.S.A. § 507. The Effective Date of this Agreement shall be the later of i) thirty (30) days from the date that PPL submits the Agreement to the PUC; or ii) if the PUC opens an investigation of the Agreement, on the date the PUC approves the Agreement.

The remainder of this page has been intentionally left blank.

SEDA-COG JRA License #08-166.0

IN WITNESS WHEREOF, the parties hereto have duly executed this License Agreement the day and year first above written.

ATTEST:

SEDA-COG JOINT RAIL AUTHORITY

DocuSigned by:  
By: Michael Krentzman  
BC473F767C554F9...  
Michael J. Krentzman  
Secretary

DocuSigned by:  
By: Russell Graham  
D9FCA19439E1432...  
Russell J. Graham  
Chairman

ATTEST:

PPL ELECTRIC UTILITIES CORPORATION

By: Nick Sweigart  
Nick Sweigart  
Right of Way Specialist

By: Austin Weseloh  
Name: Austin Weseloh  
Title: Transmission ROW & RE Supervisor

SEDA-COG JRA License #08-166.0

EXHIBIT "A"

PLANS AND SPECIFICATIONS AND DESCRIPTION OF LICENSE AREA

NO. DATE REV'D- IAB BY REV'D APPR. REVISION



PLAN SCALE: 1" = 200'

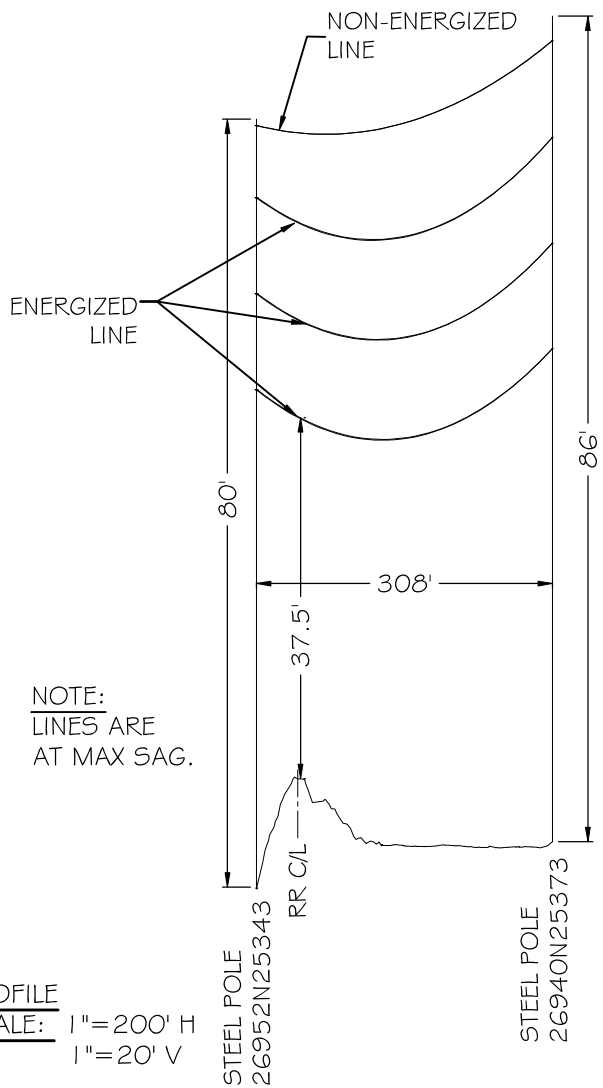
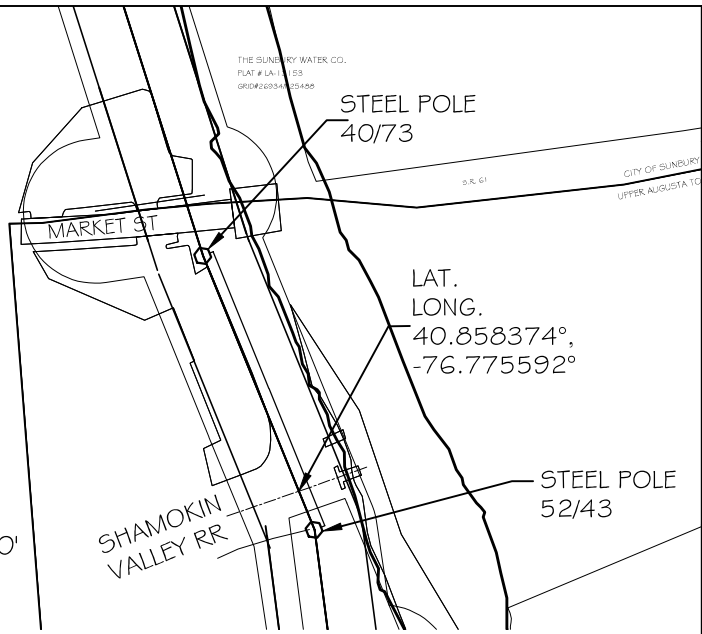

NOTE: LINES ARE AT MAX SAG.

PROFILE SCALE: 1" = 200' H  
1" = 20' V

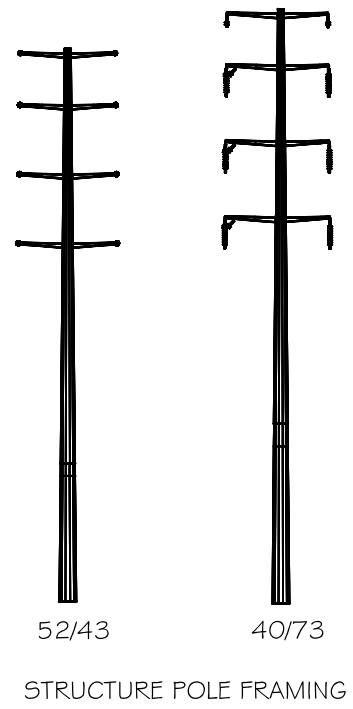

52/43 40/73  
STRUCTURE POLE FRAMING



ACCT.- 10049620  
ECN #- 16932  
SCALE- AS SHOWN  
BY- JJA  
REV'D- IAB

**PPL CROSSING (69kv)**  
PPL CROSSING SHAMOKIN VALLEY RR  
AT LAT. 40.858374, LONG. -76.775592  
MILEPOST 0001.59  
CITY OF SUNBURY NORTHUMBERLAND CO., PA

APPROVAL K. A. Toman DATE 08/2023

**PPL ELECTRIC UTILITIES**

|        |        |                   |           |          |
|--------|--------|-------------------|-----------|----------|
| AC     | A      | DRAWING NO.       | SHEET NO. | REVISION |
| CAD ID | FORMAT | <b>EU00573611</b> | <b>1</b>  | <b>0</b> |

PLAN AND PROFILE  
N SHARE  
C SORTS  
LOC CODE  
LOC CODE  
LOC CODE  
52430 PRIMARY LOC CODE