

3655 Route 202  
Suite 105  
Doylestown, PA 18902

# Thomas J. Walsh III & Associates, P.C.



Phone: 267.247.5024  
Fax: 267.247.5668  
Email: [twalsh@twalshlaw.com](mailto:twalsh@twalshlaw.com)

April 8, 2024

**Via eFiling Only**

Rosemary Chiavetta, Secretary  
Pennsylvania Public Utility Commission  
Commonwealth Keystone Building  
400 North Street  
P.O. Box 3265  
Harrisburg, PA 17105-3265

**RE: Luyando v. Newtown Artesian Water Company, Inc.  
Pennsylvania Public Utility Commission – Formal Complaint  
Docket No. F-2022-3034600**

Dear Secretary Chiavetta:

Please be advised the I am general counsel to Newtown Artesian Water Company, Inc. ("NAWC"), in the above-referenced matter.

By electronic filing, I am submitting the Answer of NAWC to the Complainant's Motion to Compel Answers to Complainant's Interrogatories Set 1, Nos. L-1 through L-26. A copy of the filing has been served directly upon all parties set forth in the attached Certificate of Service.

Thank you for your assistance in this matter. If you have any questions or require any information relating to this filing, please feel free to contact me.

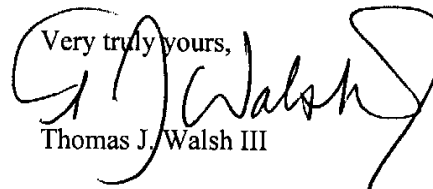
Very truly yours,  
  
Thomas J. Walsh III

TJW/

cc: Parties on Certificate of Service (via email, w/enc.)

Ltr.To PUC.2024-04-08 re NAWC Answer to Luyando Motion To Compel.docx

Thomas J. Walsh III, Esquire  
Attorney I.D. #73528  
3655 Route 202, Suite 105  
Doylestown, PA 18902  
Email: [twalsh@twalshlaw.com](mailto:twalsh@twalshlaw.com)

Attorney for Newtown  
Artesian Water Company

---

**ANN MARIE LUYANDO,**  
*Complainant*

v.

**NEWTOWN ARTESIAN  
WATER COMPANY,**  
*Respondent*

---

**PENNSYLVANIA PUBLIC  
UTILITY COMMISSION**

**I.D. #73528**

**No. F-2022-3034600**

**FORMAL COMPLAINT**

**ANSWER OF RESPONDENT NEWTOWN ARTESIAN WATER  
COMPANY TO COMPLAINANT’S MOTION TO COMPEL**

Pursuant to 52 Pa. Code §5.342(g)(1) of the Pennsylvania Public Utility Commission’s (the “PUC” or the “Commission”) Regulations, Respondent Newtown Artesian Water Company (“Company”), by and through its undersigned counsel, hereby submits this Answer (“Answer”) to the Motion of Complainant Ann Marie Luyando (“Luyando”) to Dismiss Objections and Compel Answers to Interrogatories propounded on Company (“Motion”). For the reasons set forth below, Company respectfully requests that the Honorable Administrative Law Judge Gail M. Chiodo (“ALJ”) reject Luyando’s Motion. In support of this Answer, the Company avers as follows:

**I. Introduction.**

1. The Motion and this Answer arise from a discovery dispute between Luyando and Company regarding written interrogatories propounded by Luyando upon the Company (“Set 1”). Set 1 was dated February 23, 2024. A true and correct copy of Set 1 is attached to this Answer as Exhibit “A.”

2. At a prehearing conference before the ALJ on February 29, 2024 (the “Prehearing Conference”), counsel for the Company represented to the ALJ that the Company had just received a communication from Luyando that appeared to include Set 1, but it bore no certificate of service.

3. To date, no certificate of service for Set 1 has been filed with the Commission by Luyando, in violation of 52 Pa. Code §5.341(b).

4. Notwithstanding this omission, at the Prehearing Conference, counsel for the Company advised Luyando that the Company would file and serve its written responses, together with any objections, on or before March 20, 2024.

5. On March 19, 2024, the Company served its responses and objections (collectively “Responses”) to Set 1 upon Luyando in compliance with 52 Pa. Code §52.342(a) and (e). A true and correct copy of the Responses is attached to this Answer as Exhibit “B.”

6. That same day, the Company electronically filed a copy of the related certificate of service with the Commission. A true and correct copy of the Certificate of Service of the Responses is attached to this Answer as part of Exhibit “B.”

7. As part of the Responses, the Company generally objected to interrogatories L-1 through L-26, inclusive, of Set 1 on the grounds that each interrogatory sought information that is beyond the scope of the proceeding and therefore cannot result in the discovery of admissible evidence.

8. Luyando’s Formal Complaint is limited to her allegation that she is “medically exempt” from the smart meter and related facilities proposed by the Company for her residence. A true and correct copy of the Formal Complaint is attached to this Answer as Exhibit “C.”

9. To secure such an exemption, Luyando bears the burden of proof and must present evidence, including medical or expert testimony, showing that the smart meter proposed by the Company constitutes unsafe service under Section 1501 of the Public Utility Code (the “Code”). *See* Scheduling Order dated March 5, 2024, as amended by Order dated April 5, 2024.

10. Notwithstanding this burden, Set 1 seeks the following from the Company:

- a. Manufacturer’s specifications of the smart meter, which as noted below was previously provided by Company to Luyando (L-1 and L-2);
- b. Contact information from the Company provided to the Commission (L-3 and L-4);
- c. Dates the Company commenced smart meter upgrades in Luyando’s neighborhood (L-5 and L-6);
- d. Date Luyando’s original meter was installed in her home, and Company’s service records, if any, for such original meter (L-7, L-8 and L-9);
- e. Charges related to the Company’s smart meter program, and whether those are imposed on Luyando (L-10, L-11, L-22 and L-23);

- f. Allegations of a prior offer by the Company to accommodate Luyando's exemption request (L-12 and L-13);
- g. Functioning, transmission, and reception capabilities of the proposed smart meter (L-14 through L-19, inclusive);
- h. Costs to read the water meter at Luyando's residence (L-20 and L-21); and
- i. Miscellaneous unrelated allegations and legal conclusions set forth in the Formal Complaint (L-24, L-25 and L-26).

## **II. Argument.**

11. While the Company understands and acknowledges the general breadth and scope of the Commission's discovery regulations, their reach is not limitless. Discovery is limited to matters that are "relevant to the subject matter of the pending action" and must be "reasonably calculated to lead to the discovery of admissible evidence." *See* 52 Pa. Code §5.321(c).

12. Based upon the plain language of 52 Pa. Code §5.321(c), Luyando does not have unbridled discretion to conduct discovery. The ALJ has ample discretion, consistent with applicable law, to prohibit the inquiry into the matters outlined in paragraph 10 above because none are relevant to the issue of whether or not the Company's proposed smart meter constitutes safe and reasonable service under Code Section 1501.

13. In *Povacz, et al. v. Pa. Public Utility Commission*, 280 A.3d 975 (Pa. 2022) (*Povacz II*), the Pennsylvania Supreme Court articulated the controlling standard for claims under Code Section 1501 involving the safety of smart meters and radio frequency (RF) emissions:

- a. First, a customer must present expert opinion rendered to a reasonable degree of scientific certainty that RF emissions from smart meters cause adverse health effects.
- b. Next, a customer must present expert opinion rendered to a reasonable degree of medical certainty that RF emissions from the smart meters, either alone or cumulative to other sources of RF emissions, caused them harm.

14. The *Povacz II* court concluded that neither "fear nor inconclusive scientific research [is] sufficient to prove that smart meter technology constitutes unsafe service under [Code] Section 1501." *See Povacz II*, at 1005.

15. In her Motion, Luyando claims that interrogatories L-1 through L-26 “go to the heart” of her complaint, and without the information she cannot “understand...the application of the smart water meter technology” in her home. This is erroneous. *See* Motion, p. 4.

16. As exhibits to its Answer to the Formal Complaint, the Company provided Luyando the manufacturer specifications for (a) the proposed iPERL Smart Water Meter; and (b) the Xylem SmartPoint module. A true and correct copy of the Company’s Answer to the Formal Complaint is attached hereto as Exhibit “D.”

17. Luyando’s dismissal of these sheets as “vague marketing data” is mistaken. These documents provide detailed specifications on how each product works, including the RF emission frequency range. Under *Povacz II*, it is Luyando’s burden (not the Company’s) to show how these products violate Code Section 1501. *See* Motion at p. 5.

18. Much, if not all, of the information sought in Set 1 and outlined in paragraph 10 above is wholly unrelated the allegations set forth in the Formal Complaint, as clarified by *Povacz II*. Thus, the interrogatories cannot lead to the discovery of admissible evidence.

**III. Conclusion.**

19. Based upon the foregoing, the Company should not be compelled to respond to Set 1, Nos. L-1 through L-26, inclusive.

**WHEREFORE**, Respondent Newtown Artesian Water Company respectfully requests that Complainant Luyando’s Motion be denied with prejudice.

*/s/ THOMAS J. WALSH III, Esq.*

By: \_\_\_\_\_

Thomas J. Walsh III, Esquire  
Attorney for Respondent  
Newtown Artesian Water Company

VERIFICATION

I, **Thomas J. Walsh III**, Esq., Counsel for and officer of Newtown Artesian Water Company, hereby state that the facts above set forth are true and correct to the best of my knowledge, information and belief; and that I expect to be able to prove the same at a hearing held in this matter. I understand that the statements herein are made subject to the penalties of 18 Pa. C.S. §4904 (relating to unsworn falsification to authorities).

Date: 4/8/2024

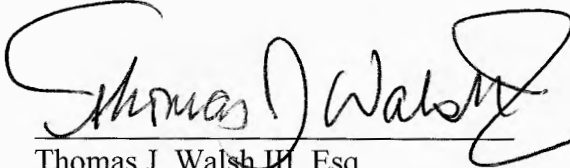
  
Thomas J. Walsh III, Esq.

Thomas J. Walsh III, Esquire  
Attorney I.D. #73528  
3655 Route 202, Suite 105  
Doylestown, PA 18902  
Email: [twalsh@twalshlaw.com](mailto:twalsh@twalshlaw.com)

Attorney for Newtown  
Artesian Water Company

---

**ANN MARIE LUYANDO,**  
*Complainant*

v.

**NEWTOWN ARTESIAN  
WATER COMPANY,**  
*Respondent*

---

**PENNSYLVANIA PUBLIC  
UTILITY COMMISSION**

**I.D. #73528**

**No. F-2022-3034600**

**FORMAL COMPLAINT**

**CERTIFICATE OF SERVICE**

I, Thomas J. Walsh III, Esquire, attorney for Respondent Newtown Artesian Water Company, hereby certify that I am this 8<sup>th</sup> day of April, 2024, serving copies of the foregoing Answer to Motion to Compel of Ann Marie Luyando, and this Certificate of Service on the following persons in the manner indicated:

By First Class Mail, Postage Prepaid

And Electronic Mail:

Ann Marie Luyando  
4 Magnolia Drive  
Newtown, PA 18940  
Email: [madisoncedric166@gmail.com](mailto:madisoncedric166@gmail.com)

By Electronic Mail:

Honorable Gail M. Chiodo  
Administrative Law Judge  
Pennsylvania Public Utility Commission  
400 North Street  
Harrisburg, PA 17120  
Email: [gchiodo@pa.gov](mailto:gchiodo@pa.gov)

I understand that any false statements herein are made subject to the penalties of 18 Pa. C.S.A. §4904 relating to unsworn falsification to authorities.

*/s/ THOMAS J. WALSH III, Esq.*

By: \_\_\_\_\_

Thomas J. Walsh III, Esquire  
Attorney for Respondent  
Newtown Artesian Water Company  
Email: [twalsh@twalshlaw.com](mailto:twalsh@twalshlaw.com)

**EXHIBIT "A"**

**SET 1**  
**WRITTEN INTERROGATORIES**

Ann M. Luyando  
Complainant

PUC No. F-2022-3034600  
ALJ Gail Chiodo

Vs

Newtown Artesian Company  
Respondent

Discovery requested from Respondent

1. Manufacturer's product spec sheets of the proposed meter with all parts included and identified, as well as how each part functions, with all EMF/RF emission details including amounts, frequencies, how frequently, etc.
2. Manufacturer's product spec sheets of all radio frequency radiation emitting and electro magnetic frequencies of the proposed attachments/components with all parts listed and identified, as well as how each part functions, with all EMF/RF emission details including amounts, frequencies, how frequently, etc.
3. Strict evidence proving the NAWC claims that the utility provided and updated Respondents' contact information including email address to the PUC for the purposes of this formal complaint within the required timeframe to file the answer, as well as when and how the information and updates were forwarded to the PUC.
4. Strict evidence that the NAWC email was "out of service" at the time and any evidence that the respondent tried to rectify the problem within the required time frame.
5. When (date) was the smart meter upgrade started in Complainants' neighborhood where she lives? When was it completed? Strict evidence requested.
6. When (date) was the smart meter upgrade started in Complainants' street where she lives? When was it completed? Strict evidence requested.
7. How old is the current analog meter at Claimants home? When was that meter installed at Complainants home address (dates)? Was it installed by NAWC? Strict evidence requested.
8. Did NAWC install an upgraded analog meter within the 20-year time limit, as required by 52Pa. code 65.8, after the current analog meter was installed at Claimants' home address? When was the meter due for an upgrade (dates)? Why wasn't the upgrade done at her residence within the required timeframe? Strict evidence requested.
9. During the time after the smart water meter upgrades were done on Complainants street where she lives, to present day, did NAWC experience any issues in reading the analog meter and collecting the data needed to fulfill the company's service obligations due to her analog water meter that remained in service during the entire time? If so, what, where, and when (dates)? Strict evidence requested.
10. From the time when the smart water meter upgrades were done on Complainants street where she lives to present day, did NAWC charge her for any smart water meter upgrade related expenses or costs and/or related equipment and services even though the company neglected to install a smart water meter upgrade at her

residence? If so, for what, when, and how much? Please provide itemized quarterly statements reflecting all costs, including any itemized hidden costs, charged to and paid by Complainant during the entire time she was billed for these costs. Strict evidence requested.

11. If NAWC billed any of the aforementioned costs and expenses related to the smart water meter upgrade she did not receive, will the company reimburse her for the full amount from the date of her street upgrades to present date? Strict evidence requested.
12. Why did NAWC rescind the previous offer made to Complainant on 5/31/22? Please provide explanation and details. Strict evidence requested.
13. Did NAWC offer to accommodate Complainants' request of an analog water meter upgrade in her residence if the PUC honored her accommodation request?
14. Would the proposed smart meter install physically include the EMF/RFR-transmitting part(s), or would that part(s) be "absent" and not physically in her home at any time?
15. What levels of EMF/RFR will the proposed smart water meter, and parts, emit? How frequently will these emissions occur? From how many smart water meter sources, parts or attachments, will the emissions be emitted?
16. If turned off or removed, would the company still be able to turn on the EMF/Radio Frequency Radiation-emitting device(s) at any time either in person or remotely? If turned off, will the meter still emit any EMF/RFR at any time in Complainants' home?
17. Would the installed meter and equipment still have wireless or power line data transmission capabilities?
18. Would the installed meter and equipment still have wireless or power line reception capabilities?
19. Would the installed meter be attached to the wiring of Complainants residence and if so, would the meter and equipment contain surge protection?
20. Would the company employee be required to make readings at Complainants home from outside the residence, or does the company demand access into the home every month for a meter usage reading?
21. What is the cost for these newly added monthly employee readings at Complainant's residence? Are there any other costs associated with this smart meter upgrade, installation, parts, equipment, services, etc., to be passed on to the Complainant, if so what are they specifically and how much is each cost? Please itemize all associated costs.
22. How much does the proposed smart meter and equipment cost?
23. Who is responsible to pay for the smart meter and equipment the company proposes to install in the Complainant's residence?
24. Did Complainant say she filed a PFA order on her PUC Formal Complaint?
25. In the untimely answer to complaint, Respondent claims that the proposed smart water meter surpasses in its safety and efficiency. Strict evidence demanded.

26. What PA codes require the water utility to upgrade smart water meters from analog water meters? Strict evidence requested.

Requested by,

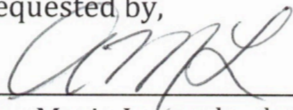
  
\_\_\_\_\_, Complainant

Ann Marie Luyando, date: Feb. 23, 2024

**EXHIBIT “B”**

**RESPONSES**

Thomas J. Walsh III, Esquire  
Attorney I.D. #73528  
3655 Route 202, Suite 105  
Doylestown, PA 18902  
Email: [twalsh@twalshlaw.com](mailto:twalsh@twalshlaw.com)

Attorney for Newtown  
Artesian Water Company

---

**ANN MARIE LUYANDO,**  
*Complainant*

v.

**NEWTOWN ARTESIAN  
WATER COMPANY,**  
*Respondent*

---

**PENNSYLVANIA PUBLIC  
UTILITY COMMISSION**

**I.D. #73528**

**No. F-2022-3034600**

**FORMAL COMPLAINT**

**NEWTOWN ARTESIAN WATER COMPANY'S  
OBJECTIONS AND RESPONSES TO INTERROGATORIES OF  
COMPLAINANT ANN MARIE LUYANDO, SET 1, DATED FEBRUARY 23, 2024**

Pursuant to 52 Pa. Code §5.342, Newtown Artesian Water Company ("NAWC") hereby objects and responds to the Interrogatories of Complainant Ann Marie Luyando ("Luyando"), Set 1:

- L-1. Manufacturer's product spec [sic] sheets of the proposed meter with all parts included and identified, as well as how each part functions, with all EMF/RF emission details including amounts, frequencies, how frequently, etc.
- L-2. Manufacturer's product spec [sic] sheets of all radio frequency radiation emitting and electro magnetic frequencies of the proposed attachments / components with all part listed and identified, as well as how each part functions, with all EMF / RF emission details including amounts, frequencies, how frequently, etc.

**Objection: Interrogatories L-1 and L-2 request information that is beyond the scope of the proceeding and therefore cannot result in the discovery of admissible evidence.**

**Response:** NAWC provided Luyando with the manufacturer's specifications for both the iPERL Smart Water Meter and the Xylem SmartPoint module. These are attached as Exhibit "A" and Exhibit "B," respectively, to NAWC's Answer and New Matter. The Formal Complaint is limited to allegations that Luyando is "medically exempt" from the smart meter and related facilities proposed for her residence. Questions regarding how the meter and module function are beyond the scope of the Formal Complaint and cannot lead to the discovery of admissible evidence.

**Response Provided By:** Daniel Angove, NAWC Chief Executive Officer  
Richard Pierone, NAWC Director of Operations

NAWC Responses to Luyando Interrogatories, Set 1

- L-3. Strict evidence proving the NAWC claims that the utility provided and updated Respondents' [sic] contact information including email address to the PUC for the purposes of this formal complaint within the required timeframe to file the answer.
- L-4. Strict evidence that the NAWC email was "out of service" at the time and any evidence that the respondent tried to rectify the problem with the required time frame.

**Objection:** Interrogatories L-3 and L-4 request information that is beyond the scope of the proceeding and therefore cannot result in the discovery of admissible evidence.

**Response:** NAWC filed its Answer and New Matter to Luyando's Formal Complaint with the Commission via eFiling on January 25, 2023 (eFiling confirmation number 2453543). At a telephonic conference and hearing held on February 29, 2024, Administrative Law Judge Gail Chiodo granted NAWC's oral motion to consider NAWC's Answer and New Matter as timely filed *nunc pro tunc*. The Formal Complaint is limited to allegations that Luyando is "medically exempt" from the smart meter and related facilities proposed for her residence. Questions regarding NAWC's contact information and status of the email address on file with the PUC are beyond the scope of the Formal Complaint and cannot lead to the discovery of admissible evidence.

**Response Provided By:** Daniel Angove, NAWC Chief Executive Officer  
Richard Pierone, NAWC Director of Operations

NAWC Responses to Luyando Interrogatories, Set 1

- L-5. When (date) was the smart meter upgrade started in Complainants' [sic] neighborhood where she lives? When was it completed? Strict evidence required.
- L-6 When (date) was the smart meter upgrade started in the Complainants' [sic] street where she lives? When was it completed? Strict evidence required.

**Objection: Interrogatories L-5 and L-6 request information that is beyond the scope of the proceeding and therefore cannot result in the discovery of admissible evidence.**

**Response:** In 2015, as part of recommendations set forth Management and Operations Audits of NAWC conducted by the Commission's Bureau of Audits, NAWC implemented a directive to replace all of its existing manually-read touchpad meters with automated meter reading (AMR) technology over a ten (10) year period. Luyando's plumber contacted NAWC in or around April 2022 to report a possible leak with the existing meter. NAWC determined that the age and type of meter at Luyando's residence warranted replacement with AMR equipment in accordance with the plan. The Formal Complaint is limited to allegations that Luyando is "medically exempt" from the smart meter and related facilities proposed for her residence. Questions regarding when NAWC conducted water meter replacements near Luyando's residence are beyond the scope of the Formal Complaint and cannot lead to the discovery of admissible evidence.

**Response Provided By:** Daniel Angove, NAWC Chief Executive Officer  
Richard Pierone, NAWC Director of Operations

NAWC Responses to Luyando Interrogatories, Set 1

- L-7. How old is the current analog meter at Claimants [sic] home? When was that meter installed at Complainants [sic] home address (dates)? Was it installed by NAWC? Strict evidence requested.
- L-8. Did NAWC install an upgraded analog meter within the 20-year time limit, as required by 52 Pa. code [sic] 65.8, after the current analog meter was installed at Claimants' [sic] home address? When was the meter due for an upgrade (dates)? Why wasn't [sic] the upgrade done at her residence within the required timeframe? Strict evidence requested.
- L-9. During the time after the smart meter upgrades were done on Complainants [sic] street where she lives, to present day, did NAWC experience any issues in reading the analog meter and collecting the data needed to fulfill the company's service obligations due to her analog water meter that remained in service during the entire time? If so, what, where, and when (dates)? Strict evidence requested.
- L-10. From the time when the smart water meter upgrades were done on Complainants [sic] street where she lives to present day, did NAWC charge her for any smart water meter upgrade related expenses or costs and/or related equipment and services even though the company neglected to install a smart water meter upgrade at her residence? If so, for what, when, and how much? Please provide itemized quarterly statements reflecting all costs, including any itemized hidden costs, charged to and paid by Complainant during the entire time she was billed for these costs. Strict evidence requested.
- L-11. If NAWC billed any of the aforementioned costs and expenses related to the smart water meter upgrade she did not receive, will the company reimburse her for the full amount from the date of her street upgrades to present date? Strict evidence requested.

**Objection:** Interrogatories L-7 through L-11, inclusive, request information that is beyond the scope of the proceeding and therefore cannot result in the discovery of admissible evidence.

**Response:** As of January 2023, the water meter serving Luyando's residence was 32 years old. NAWC does not know when the existing meter was installed. It was most likely installed by the original builder of her home when it was constructed in 1989. Like all similarly situated residents, Luyando pays only residential base rates for water service, per NAWC's tariff. The Formal Complaint is limited to allegations that Luyando is "medically exempt" from the smart meter and related facilities proposed for her residence. Questions regarding the installation date of the existing water meter, NAWC's water meter replacement program, and charges to recover meter replacement costs are beyond the scope of the Formal Complaint and cannot lead to the discovery of admissible evidence.

**Response Provided By:** Daniel Angove, NAWC Chief Executive Officer  
Richard Pierone, NAWC Director of Operations

NAWC Responses to Luyando Interrogatories, Set 1

- L-12. Why did NAWC rescind the previous offer made to Complainant on 5/31/22? Please provide explanation and details. Strict evidence requested.
- L-13. Did NAWC offer to accommodate Complainants' [sic] request of an analog water meter upgrade in her residence if the PUC honored her accommodation request?

**Objection:** Interrogatories L-12 and L-13 request information that is beyond the scope of the proceeding and therefore cannot result in the discovery of admissible evidence.

**Response:** NAWC did not make, nor rescind, any official offer to Luyando on May 31, 2022. Any such communications were discussions by Mr. Angove and Mr. Pierone to attempt to reasonably address Luyando's concerns. By letter dated January 25, 2023, in the interest of settling Luyando's Formal Complaint, NAWC made an official offer to install the iPERL meter but not attach the radio transmitting device (SmartPoint module). The Formal Complaint is limited to allegations that Luyando is "medically exempt" from the smart meter and related facilities proposed for her residence. Questions regarding offers made in the interest of settling the Formal Complaint are beyond the scope of the Formal Complaint and cannot lead to the discovery of admissible evidence.

**Response Provided By:** Daniel Angove, NAWC Chief Executive Officer  
Richard Pierone, NAWC Director of Operations

NAWC Responses to Luyando Interrogatories, Set 1

- L-14. Would the proposed smart meter install physically include the EMF / RFR-transmitting part(s), or would that part(s) [sic] be “absent” and not physically in her home at any time.
- L-15. What levels of EMF/RFR will the proposed smart water meter, and parts, emit? How frequently will these emissions occur? From how many smart water meter sources, parts, or attachments, will the emissions be emitted?
- L-16. If turned off or removed, would the company still be able to turn on the EMF/Radio Frequency Radiation-emitting device(s) at any time either in person or remotely? If turned off, will the meter still emit any EMF/RFR at any time in Complainants’ [sic] home?
- L-17. Would the installed meter and equipment still have wireless or power line data transmission capabilities?
- L-18. Would the installed meter and equipment still have wireless or power line reception capabilities?
- L-19. Would the installed meter be attached to the wiring of Complainants residence and if so, would the meter and equipment contain surge protection?

**Objection:** Interrogatories L-14 through L-19, inclusive, request information that is beyond the scope of the proceeding and therefore cannot result in the discovery of admissible evidence.

**Response:** By letter dated January 25, 2023, NAWC offered to install the iPERL meter but not attach the radio transmitting device (SmartPoint module). The replacement iPERL meter will contain a battery-operated flow measurement system. It will be attached to the existing wire that leads to the existing external touchpad at the residence that is presently used to read Luyando’s water meter. The Formal Complaint is limited to allegations that Luyando is “medically exempt” from the smart meter and related facilities proposed for her residence. Questions regarding offers made in the interest of settling the Formal Complaint, as well as the functioning, capacity, transmission and/or reception capabilities of the proposed meter, are beyond the scope of the Formal Complaint and cannot lead to the discovery of admissible evidence.

**Response Provided By:** Daniel Angove, NAWC Chief Executive Officer  
Richard Pierone, NAWC Director of Operations

NAWC Responses to Luyando Interrogatories, Set 1

- L-20. Would the company employee be required to make readings at Complainants home from outside the residence, or does the company demand access into the home every month for a meter usage reading?
- L-21. What is the cost for these newly added monthly employee readings at Complainant's residence? Are there any other costs associated with this smart meter upgrade, installation, parts, equipment, services, etc., to be passed on to the Complainant, if so what are they specifically and how much is each cost? Please itemize all associated costs.

**Objection:** Interrogatories L-20 and L-21 request information that is beyond the scope of the proceeding and therefore cannot result in the discovery of admissible evidence.

**Response:** By letter dated January 25, 2023, in the interest of settling Luyando's Formal Complaint, NAWC offered to install the iPERL meter but not attach the radio transmitting device (SmartPoint module). Under this arrangement, a NAWC employee will need to read the meter in person to determine Luyando's usage just like it is done today. The employee will remain outside Luyando's dwelling to take the reading by using a hand-held meter reader that interacts with the touchpad. Because Luyando rejected this offer, NAWC did not calculate the related labor costs and overhead to read the meter in person. The Formal Complaint is limited to allegations that Luyando is "medically exempt" from the smart meter and related facilities proposed for her residence. Questions regarding offers made in the interest of settling the Formal Complaint, as well as the functioning, capacity, transmission and/or reception capabilities of the proposed meter, are beyond the scope of the Formal Complaint and cannot lead to the discovery of admissible evidence.

**Response Provided By:** Daniel Angove, NAWC Chief Executive Officer  
Richard Pierone, NAWC Director of Operations

NAWC Responses to Luyando Interrogatories, Set 1

- L-22. How much does the proposed smart meter and equipment costs?
- L-23. Who is responsible to pay for the smart meter and equipment the company proposes to install in the Complainant’s residence?

**Objection:** Interrogatories L-22 and L-23 request information that is beyond the scope of the proceeding and therefore cannot result in the discovery of admissible evidence.

**Response:** The costs for the residential smart water meter and any related equipment are included in NAWC’s base rates and/or related surcharge. There is no separate cost imposed on NAWC’s customers for the smart water meter. The Formal Complaint is limited to allegations that Luyando is “medically exempt” from the smart meter and related facilities proposed for her residence. Questions regarding the costs of the smart meter are beyond the scope of the Formal Complaint and cannot lead to the discovery of admissible evidence.

**Response Provided By:** Daniel Angove, NAWC Chief Executive Officer  
Richard Pierone, NAWC Director of Operations

NAWC Responses to Luyando Interrogatories, Set 1

- L-24. Did Complainant say she filed a PFA order on her PUC Formal Complaint?
- L-25. In the untimely answer to complaint, Respondent claims that the proposed smart water meter surpasses in its safety and efficiency [sic]. Strict evidence demanded.
- L-26. What PA Codes require the water utility to upgrade smart water meters from analog water meters? Strict evidence requested.

**Objection:** Interrogatories L-24, L-25, and L-26 request information that is beyond the scope of the proceeding and therefore cannot result in the discovery of admissible evidence.

**Response:** The Formal Complaint is limited to allegations that Luyando is “medically exempt” from the smart meter and related facilities proposed for her residence. Questions regarding whether or not Complainant filed a PFA, the safety and efficiency of the water meter installed by NAWC, and NAWC’s water meter upgrade and replacement program are beyond the scope of the Formal Complaint and cannot lead to the discovery of admissible evidence.

**Response Provided By:** Daniel Angove, NAWC Chief Executive Officer  
Richard Pierone, NAWC Director of Operations

**VERIFICATION**

I, **Daniel J. Angove**, General Manager and Chief Executive Officer of Newtown Artesian Water Company, hereby state that the facts above set forth are true and correct to the best of my knowledge, information and belief, and that I expect to be able to prove the same at a hearing held in this matter. I understand that the statements herein are made subject to the penalties of 18 Pa. C.S. §4904 (relating to unsworn falsification to authorities).

Date: 3/18/24

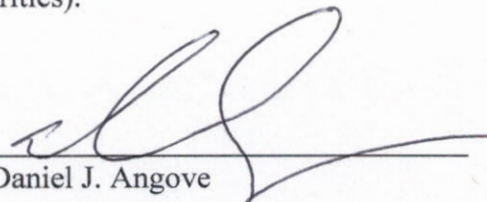
  
Daniel J. Angove

**VERIFICATION**

I, **Richard Pierone**, Director of Operations of Newtown Artesian Water Company, hereby state that the facts above set forth are true and correct to the best of my knowledge, information and belief, and that I expect to be able to prove the same at a hearing held in this matter. I understand that the statements herein are made subject to the penalties of 18 Pa. C.S. §4904 (relating to unsworn falsification to authorities).

Date: 3/18/24

  
Richard Pierone

# **EXHIBIT “C”**

## **FORMAL COMPLAINT**

## PENNSYLVANIA PUBLIC UTILITY COMMISSION

## Formal Complaint

*Filing this form begins a legal proceeding and you will be a party to the case.  
If you do not wish to be a party to the case, consider filing an informal complaint.*

**To complete this form, please type or print legibly in ink.**

**1. Customer (Complainant) Information**

Provide your name, mailing address, county, telephone number(s), e-mail address and utility account number. It is your responsibility to update the Commission with any changes to your address and to where you want documents mailed to you.

Name Ann Marie Luyando

Street/P.O. Box 4 Magnolia Dr. Apt # \_\_\_\_\_

City Newtown State Pa Zip 18940

County BUCKS

Telephone Number(s) Where We Can Contact You During the Day (required):

(267) 912-7579 (home) ( ) \_\_\_\_\_ (mobile)

E-mail Address (required): madisoncedric166@gmail.com

Utility Account Number (from your bill) NGTH-319-0

**If your complaint involves utility service provided to a different address or in a different name than your mailing address, please list this information below.**

Name \_\_\_\_\_

Street/P.O. Box \_\_\_\_\_

City \_\_\_\_\_ State \_\_\_\_\_ Zip \_\_\_\_\_

**2. Name of Utility or Company (Respondent)**

Provide the full name of the utility or company about which you are complaining. The name of your utility or company is on your bill.

Newtown Artesian Water Company

3. **Type of Utility Service**

Check the box listing the type of utility service that is the subject of your complaint (check only one):

- |   |   |
|---|---|
| <input type="checkbox"/> ELECTRIC         | <input type="checkbox"/> STORM WATER  |
| <input type="checkbox"/> GAS              | <input type="checkbox"/> WASTEWATER/SEWER                                     |
| <input checked="" type="checkbox"/> WATER | <input type="checkbox"/> TELEPHONE/TELECOMMUNICATIONS (local, long distance)  |
| <input type="checkbox"/> STEAM HEAT       | <input type="checkbox"/> MOTOR CARRIER (e.g. taxi, moving company, limousine) |

4. **Reason for Complaint**

**What kind of problem are you having with the utility or company?** Check all boxes below that apply and state the reason for your complaint. Explain specifically what you believe the utility or company has done wrong. Provide relevant details including dates, times and places and any other information that may be important. If the complaint is about billing, tell us the amount you believe is not correct. Use additional paper if you need more space. **Your complaint may be dismissed without a hearing if you do not provide specific information.**

- The utility is threatening to shut off my service or has already shut off my service.
- I would like a payment agreement.
- Incorrect charges are on my bill. Provide dates that are important and an explanation about any amounts or charges that you believe are not correct. Attach a copy of the bill(s) in question if you have it/them.
- I am having a reliability, safety or quality problem with my utility service. Explain the problem, including dates, times or places and any other relevant details that may be important.
- Other (explain).

\*1) Complainant is disabled and requested the water company install an analog meter replacement only, due to Medical exemption. This accommodation was requested by her medical doctor as well.

2) Complainant is medically exempt from all SMART meters and devices, using microwave and/or Electromagnetic radiation. (ALL electromagnetic meters and devices, etc.) Including SMART, EMF, LEM, RF, etc. meters and/or devices, etc. (NON-ANALOG meters, devices, and equipment).

3) Respondent only proposed replacing Complainant's home water meter w/non-analog meter, devices, etc. ignoring the medical exemption and the ADA accommodation request.

4) Respondent has not offered an accommodation of an analog replacement meter.

5) Complainant made numerous requests for the specs, manufacturer, model, etc of the proposed meters/devices to see if it was a safe accommodation and Respondents refused to provide me with the requested information. They only forwarded vague information that was not sufficient to make a safety determination on the proposed SMART meter. No analog meter proposed.

\* See enclosed documents.

Ann Marie Luyando  
4 Magnolia Drive  
Newtown, PA 18940

May 13, 2022

Richard Pierone, General Manager  
Newtown Artesian Water Company  
201 N. Lincoln Avenue  
Newtown, PA 18940  
(215) 968-6781

RE: Disability Accommodation Request

Dear Rich,

I am writing to request that you please allow a disability accommodation for a water meter replacement at my home address that does not emit any electromagnetic frequencies (LEF or EMF), such as the SMART meter or other. Please install the same type of meter as the existing one. Another feasible option is to not replace the existing meter at all, as this meter is not presenting any problems with accuracy or service.

As per your instructions I initially contacted PUC with regard to my disability accommodation request. The PUC investigator has since contacted me and asked me to attach my doctor's medical letter to my request and has instructed me to forward the request again to your attention at the water company. Enclosed please find my medical letter.

Please let me know if at this time the Newtown Artesian Water Company is still denying my disability accommodation request. A written response is requested from you within 10 days of receipt of this letter.

Thank you.

Sincerely,



Ann Marie Luyando  
Enclosure, aml

cc: Public Utility Commission (PUC)



# The Institute for Respiratory and Sleep Medicine

---

05/10/22

AnnMarie Luyando  
DOB 01/25/1965

To whom it may concern:

This patient has a complex medical history which has resulted in disability. Underlying problems include systemic lupus erythematosus, postural orthostatic hypotension syndrome (POTS), chronic migraines, and cardiac dysrhythmia. She has exhibited hypersensitivity to microwave and electromagnetic radiation. She has been advised that the utility company is planning on converting her house to a "smart water meter" which may have the potential to adversely affect her health. I would respectfully request for appropriate accommodations so as to minimize the potential for health risk in this patient. Chronic exposure to electromagnetic magnetic frequencies is likely to exacerbate her health conditions.

Sincerely,

Peter C Serpico, DO, FACOI

---

1000 Floral Vale Blvd  
Suite 125  
Yardley, PA 19067  
P: (267) 759-6300  
F: (215) 757-0604

Howard J. Lee, MD | Richard D. Shusterman, MD  
Bruce D. Dershaw, MD | Peter C. Serpico, DO  
Rudolf Khusid, MD | Thomas Drames, DO  
Mitchell D. Jacobs, MD | Mark Benjamin, MD

2630 Holme Ave  
Suite 104  
Philadelphia, PA 19152  
P: (215) 332-9095  
F: (215) 333-8903

Note: If your complaint is only about removing or modifying a municipal lien filed by the City of Philadelphia, the Public Utility Commission (PUC) cannot address it. Only local courts in Philadelphia County can address this type of complaint. The PUC can address a complaint about service or incorrect billing even if that amount is subject to a lien.

In addition, the PUC generally does not handle complaints about cell phone or Internet service, but may be able to resolve a dispute regarding voice communications over the Internet (including the inability to make voice 911/E911 emergency calls) or concerns about high-speed access to Internet service.

## 5. Requested Relief

**How do you want your complaint to be resolved?** Explain what you want the PUC to order the utility or company to do. Use additional paper if you need more space.

1. Replace existing analog home water meter with an analog meter, devices and equipment that utilizes only analog technology, like the existing analog meter in her home. -OR-
2. Leave the existing analog meter in place, Respondents also have the option to leave the existing analog meter in place as it is in good working order without any problems.

Note: The PUC can decide that a customer was not billed correctly and can order billing refunds. The PUC can also fine a utility or company for not following rules and can order a utility or company to correct a problem with your service. Under state law, the PUC cannot decide whether a utility or company should pay customers for loss or damages. Damage claims may be sought in an appropriate civil court.

6. Protection From Abuse (PFA)/ Domestic Violence

Has a court granted you a “Protection From Abuse” order or any other order which provides clear evidence of domestic violence against you that is currently in effect for your personal safety or welfare? The PUC needs this information to properly process your complaint so that your identity is not made public.

Note: You must answer this question if your complaint is against a natural gas distribution utility, an electric distribution utility or a water distribution utility AND your complaint is about a problem involving billing, a request to receive service, a security deposit request, termination of service or a request for a payment agreement.

Has a court granted a “Protection From Abuse” order or any other order for your personal safety or welfare?

YES

NO

If your answer to the above question is “yes,” attach a copy of the current Protection From Abuse order to this Formal Complaint form.

7. Prior Utility Contact

a. Is this an appeal from a decision of the PUC’s Bureau of Consumer Services (BCS)?

YES

NO

Note: If you answered yes, move to Section 8. No further contact with the utility or company is required. If you answered no, answer the question in Section 7 b. and answer the question in Section 7 c. if relevant.

b. If this is not an appeal from a BCS decision, have you spoken to a utility or company representative about this complaint?

YES

NO

Note: You must contact the utility first if (1) you are a residential customer, (2) your complaint is against a natural gas distribution utility, an electric distribution utility or a water utility AND (3) your complaint is about a billing problem, a service problem, a termination of service problem, or a request for a payment agreement.

- c. If you tried to speak to a utility company representative about your complaint but were not able to do so, please explain why.

Note: Even if you are not required to contact the utility or company, you should always try to speak to a utility or company representative about your problem before you file a Formal Complaint with the PUC.

8. **Legal Representation**

If you are filing a Formal Complaint as an individual on your own behalf, you are **not** required to have a lawyer. You may represent yourself at the hearing.

If you are already represented by a lawyer **in this matter**, provide your lawyer's name, address, telephone number, and e-mail address, (all required contact information). Please make sure your lawyer is aware of your complaint. If represented by a lawyer, both you and your lawyer must be present at your hearing.

Lawyer's Name \_\_\_\_\_

Street/P.O. Box \_\_\_\_\_

City \_\_\_\_\_ State \_\_\_\_\_ Zip \_\_\_\_\_

Area Code/Phone Number \_\_\_\_\_

E-mail Address \_\_\_\_\_

Note: Corporations, associations, partnerships, limited liability companies and political subdivisions are required to have a lawyer represent them at a hearing and to file any motions, answers, briefs or other legal pleadings.



# **EXHIBIT “D”**

## **ANSWER AND NEW MATTER TO FORMAL COMPLAINT**



3. Denied. Company offered to install a replacement digital water meter at Luyando's residence with the separate radio transmitting feature absent. Luyando rejected Company's accommodation.
4. Denied. Company never offered nor agreed to install an analog water meter at Luyando's residence, as an "accommodation" or otherwise. Company did offer Luyando an accommodation by (a) offering to install a replacement digital water meter at Luyando's residence with the radio transmitting feature absent; and (b) allowing Luyando to send her water meter reading to the Company on a monthly basis. Luyando rejected Company's accommodation.
5. Admitted in part; denied in part. Admitted that Company never offered nor agreed to install an analog water meter at Luyando's residence. Denied that Company did not forward specifications of the replacement digital water meter to Luyando, per her request. A copy of the digital meter specifications sent to Luyando are attached hereto as Exhibit "A."

As to the remaining averments the same are denied, since after reasonable investigation, Company is without knowledge or information sufficient to form a belief as to the truth of these averments. Strict proof thereof is demanded at the hearing, if relevant.

5. **Requested Relief.** Denied. Company will not offer nor agree to install an analog or mechanical water meter at Luyando's residence. Company will not agree to leave Luyando's existing 32 year old meter at her residence. Company has a regulatory obligation to replace aging meters.
6. **Protection From Abuse (PFA) / Domestic Violence.** Denied. After reasonable investigation, Company is without knowledge or information sufficient to form a belief as to the truth of these averments. Strict proof thereof is demanded at the hearing, if relevant.
7. **Prior Utility Contact.** No response required.
8. **Legal Representation.** No response required.
9. **Verification and Signature.** No response required.
10. **How to File Your Complaint.** No response required.

**WHEREFORE**, Respondent Newtown Artesian Water Company respectfully requests that Complainant Luyando's Formal Complaint be dismissed, with prejudice.

## NEW MATTER

11. Company incorporates by reference paragraphs 1 through 10, inclusive, as though the same were fully set forth herein at length.
12. Luyando resides at 4 Magnolia Drive, Newtown Township, Bucks County, PA 18940. Company provides residential water service to and a water meter at Luyando's residence. *See* 52 Pa Code §65.7.
13. Luyando's existing water meter is 32 years old. Luyando's existing water meter is mechanical and does not possess a remote reading device. It is scheduled to be replaced in accordance with the Company's meter replacement program and applicable Commission regulations. *See* 52 Pa Code §65.8.
14. All replacement water meters installed by the Company must contain devices that utilize approved and required remote reading capability. Company cannot re-install a mechanical or analog meter at Luyando's residence. The Company does not offer, and is not required to offer, an "opt-out" program for non-remote reading meters.
15. Nonetheless, Company offered to install the iPERL meter (described in Exhibit "A") at Luyando's residence. The iPERL meter uses solid state remanent magnetic technology to measure water flows. This type of meter provides superior water consumption readings, better leak detection, and is more durable than an older mechanical or analog meter.
16. An internal lithium-ion battery provides power to the iPERL meter for the measuring processors. The iPERL meter and lithium-ion battery, by themselves, do not emit radiofrequency (RF) radiation.
17. The water use data collected by the iPERL meter is sent to the Company through a separate device identified as the SmartPoint module. The SmartPoint module is a radio transmitter that, when conveying data to the Company's receiving device, does emit a safe level of RF radiation. A copy of the SmartPoint module's specifications is attached hereto as Exhibit "B."

- 18. As an accommodation to Luyando, the Company offered to not install the SmartPoint module on the new iPERL meter at Luyando’s residence. The Company conditioned its offer on Luyando personally delivering the meter reading to Company on a monthly basis to enable the Company to conduct proper billing. Luyando rejected this offer.
  
- 19. The digital meter with remote reading capability proposed to be installed by Company complies with its obligation to provide “adequate, efficient, safe, and reasonable” water service and facilities to Luyando at her residence. *See* 66 Pa.C.S. §1501.

**WHEREFORE**, Respondent Newtown Artesian Water Company respectfully requests that Complainant Luyando’s Formal Complaint be dismissed, with prejudice.

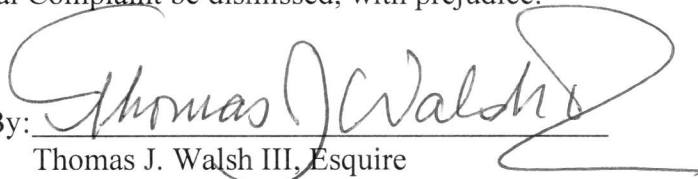
By:   
Thomas J. Walsh III, Esquire  
Attorney for Respondent  
Newtown Artesian Water Company

**VERIFICATION**

I, **Thomas J. Walsh III, Esq.**, Counsel for and officer of Newtown Artesian Water Company, verify that the statements made in the foregoing Answer and New Matter are true and correct to the best of my knowledge, information and belief and I understand that false statements herein are made subject to the penalties of 18 Pa. C.S. §4904, relating to unsworn falsification to authorities.

Date: 1/25/2023

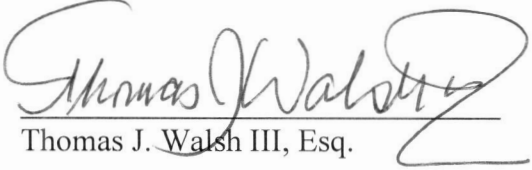
  
Thomas J. Walsh III, Esq.

# **EXHIBIT “A”**

## **iPERL METER SPECIFICATIONS**

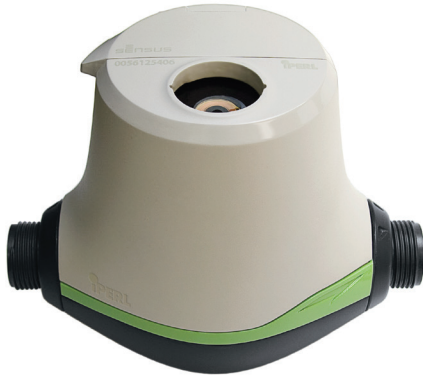

# iPERL Smart Water Meter

## Electromagnetic Flow Measurement System

### CAPABILITIES

- The iPERL meter has an operating range of 0.11 gpm (0.025 m<sup>3</sup>/hr) to 55 gpm (12.5 m<sup>3</sup>/hr)—it even starts to register flow as low as 0.03 gpm (0.007 m<sup>3</sup>/hr).
- Sizes include: 5/8" (DN 15mm), 3/4" (DN 20mm) and 1" (DN 25mm)
- iPERL can be installed horizontally, vertically or diagonally.

### BENEFITS

- Maximize investment with iPERL's magnetic technology, which delivers a 20-year accuracy warranty, with no repairs
- Get smart water alarms to detect issues such as leaks, reverse flow, empty pipe, etc.
- Improve low flow accuracy to drive additional revenue

Sensus iPERL<sup>®</sup> smart water meters are designed to capture both lost water and lost revenue. The innovative magnetic technology delivers unmatched low flow registration and minimal pressure loss. With no moving parts, iPERL maintains its accuracy over a 20 year lifetime and is equipped with smart water alarms – delivering the intelligence you need to quickly resolve issues in the field.

### Industry Leading Performance

The patented measurement technology of the iPERL water meter provides enhanced accuracy at both low and high flows. Over a 20-year lifespan, your iPERL will measure just as accurately as the day it was installed.

### Solid State Magnetic Technology

By avoiding the use of a mechanical measuring element inside the flow tube, metering performance is linear over the entire flow range – ensuring no reduction in accuracy at any flow rate over the life of the meter. The iPERL meter uses our patented remanent magnetic field technology – requiring far less energy and delivering superior accuracy.

### Alarms

Quick resolution of field issues is made possible with smart water alarms including leak detection, reverse flow, empty pipe, magnetic tamper and low battery. When integrated with our FlexNet<sup>®</sup> communication network, remotely gathering and transmitting data has never been more reliable or profitable.

### Construction

The iPERL meter body is made of composite alloy and contains no metal material. Inside the meter body is an electronic register and a measuring device that is comprised of a composite alloy flow tube. Embedded in the flow tube are coated silver electrodes. iPERL utilizes these to measure the fluid velocity through the flow tube – enabling less power consumption and predictable meter performance. The iPERL meter has a 20-year accuracy warranty and a 20-year battery life guarantee.



# iPERL Smart Water Meter

## Electronic Register

The 9-digit hermetically-sealed electronic register with LCD display was designed to eliminate dirt, fog and moisture contamination in pit settings. The large, easy-to-read display includes AMR digits, direction of flow, units of measure and smart water alarms. The AMR digits and units of measure are fully programmable. The register also provides integrated customer data logging.

## AMI / AMR Compatibility

Sensus iPERL meters are compatible with common AMR/AMI systems, including the Sensus FlexNet® communication network.

## Conformance to Standards

The iPERL meter far exceeds the most recent revision of ANSI/AWWA Standard C-700 and C-710 for accuracy and pressure loss requirements. All iPERL meters are NSF/ANSI Standard 61 Annex F and G compliant and tested to AWWA standards.

## Tamper Resistant

The integrated construction of the iPERL water meter prevents removal of the register to obtain free water. The magnetic tamper and low field alarms will both indicate any attempt to tamper with the magnetic field of the iPERL meter.

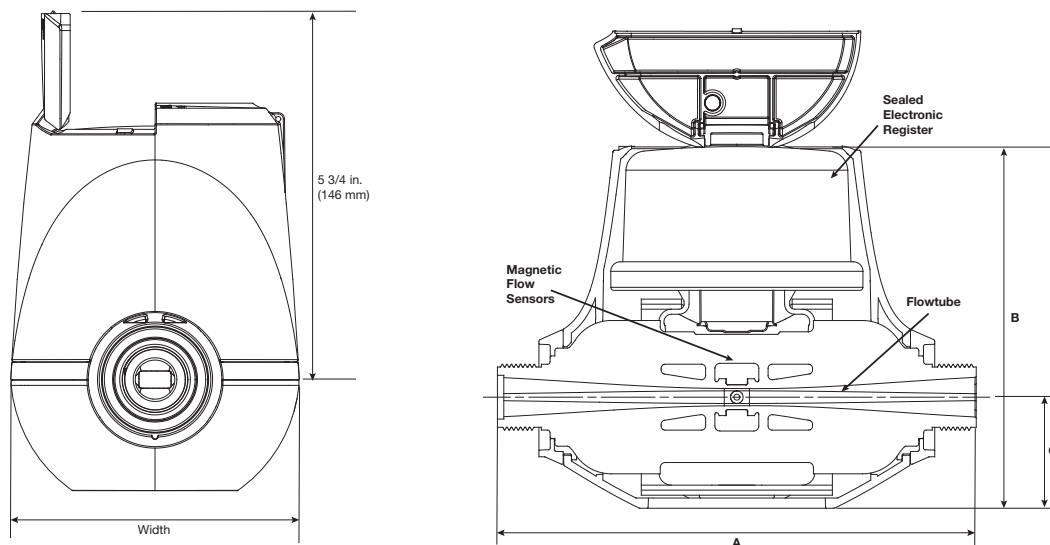

## Dimensions and Net Weights

Size	A (lay length)	B	C	Spud Ends	NPSM Thread Size	Width	Net Weight
5/8" (DN 15 mm)	7-1/2" (190 mm)	6-1/10" (155 mm)	1-3/4" (44 mm)	5/8" (15 mm)	3/4" (19 mm)	4-1/2" (114 mm)	3.1 lb. (1.4 kg)
3/4"S (5/8" x 3/4") (DN 20 mm)	7-1/2" (190 mm)	6-1/10" (155 mm)	1-3/4" (44 mm)	3/4" (20 mm)	1" (25 mm)	4-1/2" (114 mm)	3.1 lb. (1.4 kg)
3/4" (DN 20 mm)	9" (229 mm)	6-1/10" (155 mm)	1-3/4" (44 mm)	3/4" (20 mm)	1" (25 mm)	4-1/2" (114 mm)	3.2 lb. (1.5 kg)
1" (DN 25 mm)	10-3/4" (273 mm)	6-1/10" (155 mm)	1-3/4" (44 mm)	1" (25 mm)	1-1/4" (32 mm)	4-1/2" (114 mm)	3.3 lb. (1.6 kg)



## Specifications

Service	Measurement of potable and reclaimed water. Water operating temperature range of 33°F (0.56°C) -80°F (26.7°C)
Starting Flow	5/8" (DN 15mm) size: 0.03 gpm (0.007 m <sup>3</sup> /h) 3/4" (DN 20mm) size: 0.03 gpm (0.007 m <sup>3</sup> /h) 1" (DN 25mm) size: 0.11 gpm (0.025 m <sup>3</sup> /h)
Low Flow Range (±3%)	5/8" (DN 15mm) size: >0.11 gpm (0.025 m <sup>3</sup> /hr) to <0.18 gpm (0.041 m <sup>3</sup> /hr) 3/4" (DN 20mm) size: >0.11 gpm (0.025 m <sup>3</sup> /hr) to <0.18 gpm (0.041 m <sup>3</sup> /hr) 1" (DN 25mm) size: >0.3 gpm (0.068 m <sup>3</sup> /hr) to <0.4 gpm (0.09 m <sup>3</sup> /hr)
Normal Water Operating Flow Range (±1.5%)	5/8" (DN 15mm) size: 0.18 to 25 gpm (0.04 to 5.7 m <sup>3</sup> /hr) 3/4" (DN 20mm) size: 0.18 to 35 gpm (0.04 to 8.0 m <sup>3</sup> /hr) 1" (DN 25mm) size: 0.4 to 55 gpm (0.09 to 12.5 m <sup>3</sup> /hr)
Maximum Operating Pressure	5/8" and 3/4" size: 200 psi (13.8 bar) 1" size: 175 psi (12.1 bar)
Measurement Technology	Solid state electromagnetic flow
Register	Hermetically sealed, 9-digit programmable electronic register; AMR/AMI compatible; iPERL register programmable using the UniPro <sup>®</sup> communicator and FieldLogic <sup>™</sup> software
Materials	External housing – Thermal plastic; Flowtube – Polyphenylene sulfide alloy; Electrode – Silver/silver chloride; Register cover – Tempered glass
Alarm Defaults	Alarm Duration – 90 days; Leak Duration before alarm is triggered – 24 hours; Datalog Interval – 1 hour; Alarm Mask

## Headloss Curves

5/8" Headloss Curve

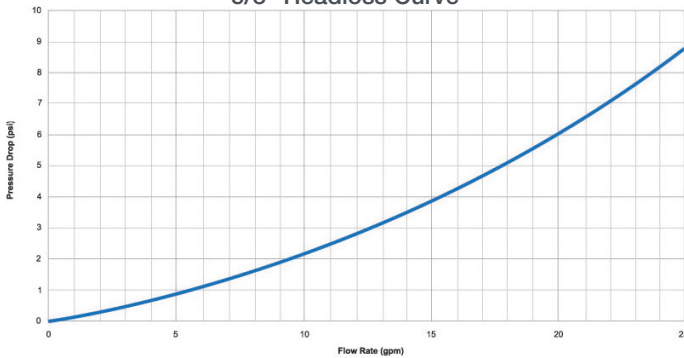

3/4" Headloss Curve

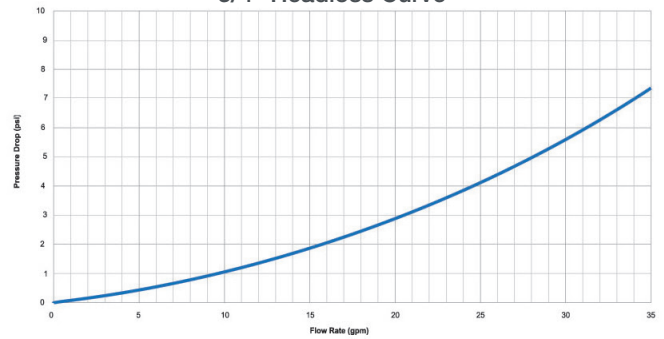

3/4" Short Headloss Curve



1" Headloss Curve

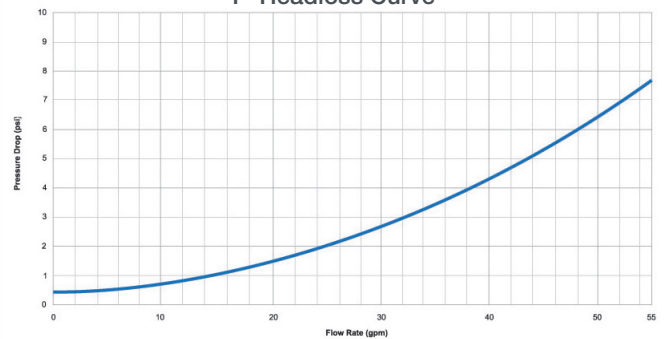

# **EXHIBIT “B”**

## **SMARTPOINT MODULE SPECIFICATIONS**



## SmartPoint 510M

### Non-Pit Set Module

The SmartPoint® 510M Non-Pit Set Module is a radio transceiver that provides water utilities inbound and outbound access to water measurement and ancillary device diagnostics via radio signal. The SmartPoint 510M Module is designed for non-submersible/non-pit installations.

### TouchCoupler Design

The SmartPoint 510M Module utilizes TouchCoupler, the patented Sensus inductive coupling communication platform, to interface with the encoded meter. With TouchCoupler, the SmartPoint 510M Module can connect to the meter using existing two-wire AMR installations instead of requiring utilities to access the home to install a new three-wire system. This results in a fast, efficient and reliable connection at minimal cost.

### BENEFITS

- Easily receives input from either walk-by/drive-by or fixed-base collection device
- Controls both deployment and lifetime operation costs
- Compact installation that saves time, space and money - without reducing system performance
- Delivers a fast, efficient, reliable connection at minimal cost
- Minimizes new infrastructure investment
- Enables effective leak detection

### Operation

With its migratable, two-way communication ability, the M-Series SmartPoint functions as a walk-by/drive-by endpoint, fixed-base endpoint, or combination of the two. This flexibility increases utility data collection capabilities and streamlines operations. The SmartPoint 510M Module receives input from the meter register and remotely sends data to a walk-by/drive-by or fixed-base collection device. The SmartPoint 510M Module easily migrates from walk-by/drive-by to fixed base by simply installing a Base Station.

In walk-by/drive-by mode, the SmartPoint 510M Module collects data and awaits an activation signal from the Vehicle Gateway Basestation (VGB) or Hand-Held Device (HHD). Upon signal receipt, it transmits readings, the meter identification number and any alarms.

As a fixed-base endpoint, the SmartPoint 510M Module interacts with one or more strategically placed Base Stations located in the utility service area. Top of the hour readings and other diagnostics are instantly forwarded to the Regional Network Interface (RNI)™ at time of transmission. The FlexNet® communication network provides unmatched reliability by using expansive tower receiver coverage of metering end points, data/message redundancy, failover backup provisions and operation on FCC primary use (unshared) RF spectrum.

### Powerful Transmission, Flexible Platform

The SmartPoint® 510M Non-Pit Set Module offers several advantages that control both deployment and lifetime operation costs. Its powerful, industry leading two watt transmitter broadcasts over large distances and minimizes collection infrastructure. And after the SmartPoint 510M Module is installed, its migratable, two-way system platform can be updated without requiring personnel to visit each meter and/or inconveniencing customers.

# SmartPoint 510M

## Non-Pit Set Module

### Additional SmartPoint 510M Module Features

The SmartPoint 510M Module obtains hourly readings and can monitor continuous flow over a programmable period of time, alerting the utility to leak conditions. In addition, the SmartPoint 510M Module stores up to 840 consumption intervals (35 days of hourly consumption), providing the utility with the ability to

extract detailed usage profiles for consumer information and dispute resolution. The SmartPoint 510M Module also incorporates a two-port design, allowing the utility to connect multiple registers and ancillary devices (such as acoustic monitoring) to a single SmartPoint. This results in a compact installation that saves time, space and money - without reducing system performance.

### SPECIFICATIONS

Service	Wall mounted (non-pit/non-submersible) installation interfacing the utility meter to the Sensus FlexNet system.
Physical characteristics	Width: 5 9/16" x Height: 5 1/2" x Depth: 3"
Weight	1.13 lbs/18.08 oz
Color	Tan
Frequency range	900 - 950 MHz, 8000 channels X 6.25 kHz steps
Modulation	Proprietary Narrow Band
Memory	Non-Volatile
Power	Lithium Thionyl Chloride batteries
Approvals	US: FCC CFR 47: Part 24D, Part 101C, Part 15 Licensed operation Canada: Industry Canada (IC) RSS-134, RSS-119
Operating temperature	- 22° F to +185° F - 30° C to + 85° C
Options	Dual or single port availability; TouchCoupler only, wired only
Installation environment	The 510M is designed for side-of-home applications where it is not subject to submergence.
Compatibility	TouchCoupler and Wired Version: Sensus Encoder Registers, Badger ADE water registers, Master Meter AccuLinx, and Hersey Translator (approved TR/PL Lead)  Wired Version Only: Elster Encoder (Sensus protocol), Neptune ARB VI (ProRead), Hersey Translator, Zenner PMN Nitro 01, McCrometer flowcom FC100-00M, and Kamstrup flowIQ 2100  Refer to the 510M/520M SmartPoint® Module Water Meter and Ancillaries Compatibility Quick Guide for the latest compatibility information.
Warranty	20 years - Based on six transmissions per day. Refer to Sensus G-500 for warranty.



Thomas J. Walsh III, Esquire  
Attorney I.D. #73528  
3655 Route 202, Suite 105  
Doylestown, PA 18902  
Email: [twalsh@twalshlaw.com](mailto:twalsh@twalshlaw.com)

Attorney for Newtown  
Artesian Water Company

---

**ANN MARIE LUYANDO,**  
*Complainant*

v.

**NEWTOWN ARTESIAN  
WATER COMPANY,**  
*Respondent*

---

**PENNSYLVANIA PUBLIC  
UTILITY COMMISSION**

**I.D. #73528**

**No. F-2022-3034600**

**FORMAL COMPLAINT**

**CERTIFICATE OF SERVICE**

I, Thomas J. Walsh III, Esquire, attorney for Respondent Newtown Artesian Water Company, hereby certify that I am this 25<sup>th</sup> day of January, 2023, serving copies of the foregoing Answer and New Matter and this proof of service on the following persons in the manner indicated: by first class regular mail, postage prepaid:

By First Class Mail, Postage Prepaid:

Ann Marie Luyando  
4 Magnolia Drive  
Newtown, PA 18940

By Electronic Mail:

Honorable Gail M. Chiodo  
Administrative Law Judge  
Pennsylvania Public Utility Commission  
400 North Street  
Harrisburg, PA 17120  
Email: [gchiodo@pa.gov](mailto:gchiodo@pa.gov)

I understand that any false statements herein are made subject to the penalties of 18 Pa. C.S.A. §4904 relating to unsworn falsification to authorities.

By:

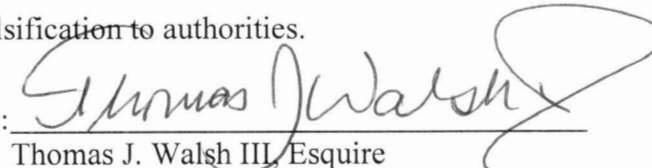

Thomas J. Walsh III, Esquire  
Attorney for Respondent  
Newtown Artesian Water Company  
Email: [twalsh@twalshlaw.com](mailto:twalsh@twalshlaw.com)