



**Verizon Pennsylvania LLC
Right of Way Department**

Kathleen Meeks
40 S. Mercer St.
New Castle, PA 16101

Cell: 724-636-9515
Phone: 724-652-6375
Kathleen.Meeks@verizon.com

May 22, 2024

Ms. Rosemary Chiavetta, Secretary
PA Public Utility Commission
P. O. Box 3265
Harrisburg, PA 17105-3265

RE:DOT SR3009-60

Township of Upper Chichester, Delaware County

Dear Ms. Chiavetta:

Enclosed is an application to the PUC for Verizon Pennsylvania LLC to place a fiber optic cable crossing in the Township of Upper Chichester, County of Delaware and must cross the CSX Railroad, in the public right of way of Chichester Road Bridge, Crossing SR3009-60.

All parties have been notified.

Sincerely

Kathleen Meeks
Engineer III-Specialist

**BEFORE
PENNSYLVANIA PUBLIC UTILITY COMMISSION**

In re: Application of Verizon Pennsylvania LLC for approval to place an aerial fiber optic cable located in the Township of Upper Chichester, Delaware County. To complete this work, we must cross CSX Railroad in the public right of way of Route 3009, Crossing #SR3009-60

Application
Docket No.

To Pennsylvania Public Utility Commission:

1. The name and address of applicant are
Verizon Pennsylvania LLC
Attn: Kathleen Meeks
40 S. Mercer St.
New Castle, PA 16101

-
2. The name and address of applicant's attorney are

Susan D. Paiva
Assistant General Counsel
900 Race Street
6th Floor
Philadelphia, PA 19107

3. Verizon Pennsylvania LLC requests permission to construct a new fiber cable in Boothwyn, Upper Chichester Township, Delaware County. **Projected Start Date for this project is October 1, 2024.**
4. The proposed construction will involve a placement of a new fiber optic cable attached to existing messenger strand on PECO poles (Exhibit A)
5. The municipalities and property owners concerned in, or affected by, the crossing alterations are in Exhibit "B".
6. The motoring public will not be impacted. Rail traffic will need to be stopped for approximately 30 minutes. Verizon Pennsylvania LLC will use normal construction procedures. Normal procedures will be followed including the use of flagmen to maintain normal flow of traffic.
7. The estimated cost of this construction project is \$20,000. Completion Date March 1, 2025.

8. The construction is necessary or proper for the following reasons: The alterations at this crossing are necessary for Verizon Pennsylvania LLC to eliminate a construction conflict with a CSX plan to construct drainage ditches along the tracks. A 24" steel casing has been identified as in conflict at Sta. 955+50.

Wherefore, applicant prays your Honorable Commission to approve the application:

Kathleen Meeks

1.36. Verification.

(a) Applications, petitions, formal complaints, motions and answers thereto containing an averment of fact not appearing of record in the action or containing a denial of fact shall be personally verified by a party thereto or by an authorized officer of the party if a corporation or association. Verification means a signed written statement of fact supported by oath or affirmation or made subject to the penalties of 18 Pa. C.S. §4904 (relating to unsworn falsification to authorities). If verification is required, notarization is not necessary.

(b) The Verification form should comply substantially with the following:

VERIFICATION

I, Kathleen Meeks, hereby state that the facts above set forth are true and correct (or are true and correct to the best of my knowledge, information and belief) and that I expect to be able to prove the same at a hearing held in this matter. I understand that the statements herein are made subject to the penalties of 18 Pa. C.S. § 4904 (relating to unsworn falsification to authorities).

Date: 5/22/24 Kathleen Meeks
(Signature)

CERTIFICATE OF SERVICE

I hereby certify that I have this day served a true copy of the foregoing document upon the participants, listed below, in accordance with the requirements of § 1.54

Daniel D. Leonard, P.E. | Grade Crossing Engineer
PA Department of Transportation | Bureau of Project Delivery
Highway Delivery Division | Utilities and Right-of-Way Section
400 North Street, 7th Floor | Harrisburg, PA 17120
danleonard@pa.gov

Karen Cummings
Senior Assistant Counsel
Governors Office of General Counsel
Department of Transportation
Office of Chief Counsel/Real Property Division
P.O. Box 8212, Harrisburg, PA 17105-8212
kcummings@pa.gov

Pennsylvania Department of Transportation District 6
District Executive
7000 Geerdes Boulevard
King of Prussia, PA 19406-1525

Upper Chichester Township
Public Works
8500 Furey Road
Upper Chichester, PA 19014

PECO
Diana Gaiser, Joint Use Coordinator
2301 Marker Street, N3-3
Philadelphia, PA 19103

CSX Transportation
Nensi Patel- Sr Track Analyst
500 WATER STREET- Cubicle 12053
JACKSONVILLE, FLA 32202

Dated this 22nd day of May 2024

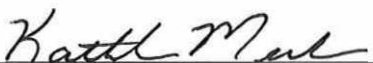

(Signature)

Exhibit B

Daniel D. Leonard, P.E. | Grade Crossing Engineer
PA Department of Transportation | Bureau of Project Delivery
Highway Delivery Division | Utilities and Right-of-Way Section
400 North Street, 7th Floor | Harrisburg, PA 17120
danleonard@pa.gov

Karen Cummings
Senior Assistant Counsel
Governors Office of General Counsel
Department of Transportation
Office of Chief Counsel/Real Property Division
P.O. Box 8212, Harrisburg, PA 17105-8212
kcummings@pa.gov

Pennsylvania Department of Transportation District 6
District Executive
7000 Geerdes Boulevard
King of Prussia, PA 19406-1525

Upper Chichester Township
Public Works
8500 Furey Road
Upper Chichester, PA 19014

PECO
Diana Gaiser, Joint Use Coordinator
2301 Marker Street, N3-3
Philadelphia, PA 19103

CSX Transportation
Nensi Patel- Sr Track Analyst
500 WATER STREET- Cubicle 12053
JACKSONVILLE, FLA 32202

Dated this 22nd day of May 2024



(Signature)

06/11/2024 C:\Users\jgroms\OneDrive - Pike Enterprises, LLC\Documents\AutoCAD\VER PERMIT\CHICHESTER AVE 4.1.2\004A PERMIT CHICHESTER AVE 4.1.2.dwg

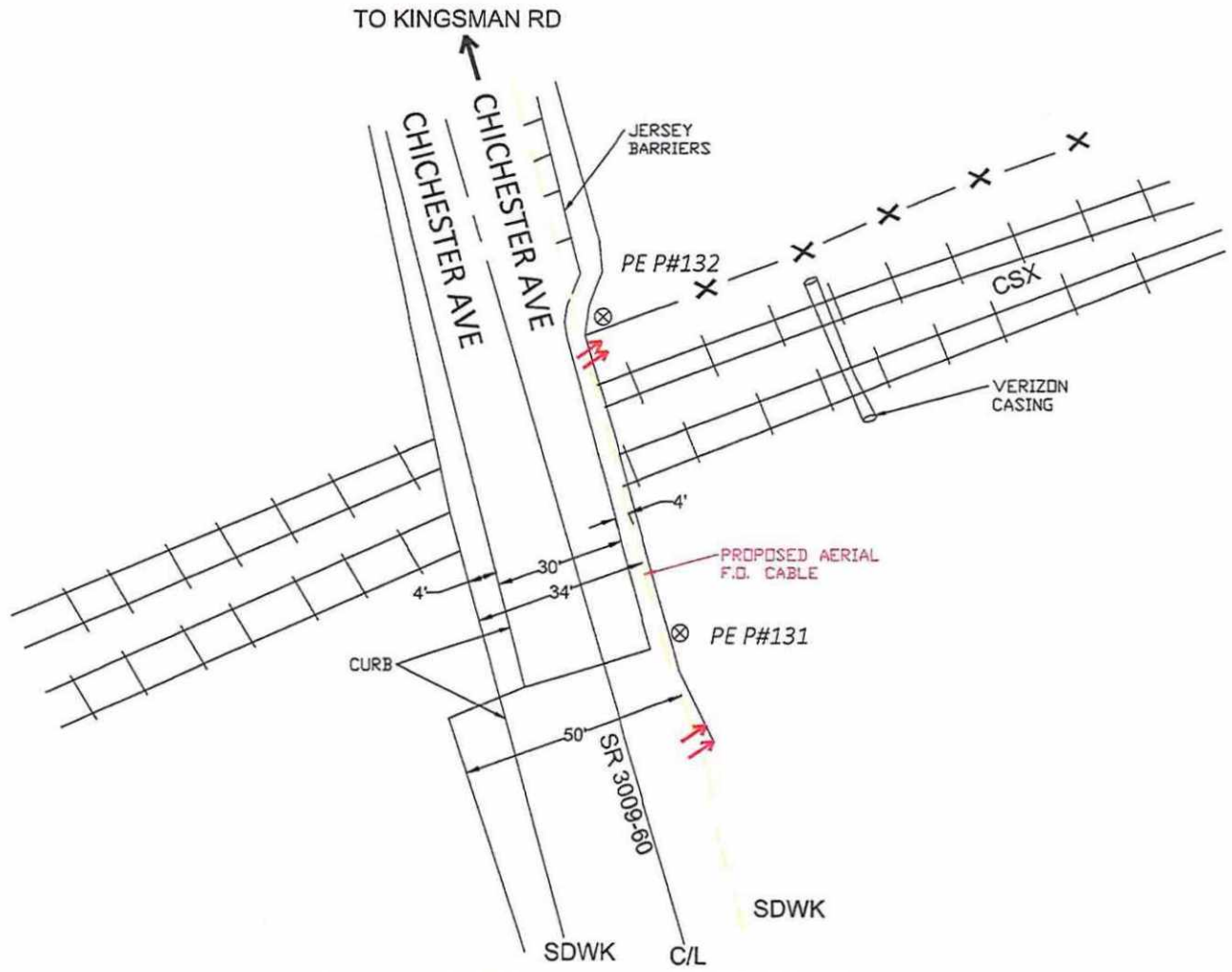

LEGEND: (PROPOSED ———), (EXISTING ———)			STRAND	
YYY BOX				
COYOTE BOX				
S-ONE BOX				
FIBER DISTRIBUTION HUB				
FIBER DISTRIBUTION TERMINAL				
HANDHOLE				
MANHOLE				
SLACK STORAGE BOX				
CORNING CLEAR TRACK SSB				
COLLECTOR PLATE				
CORE DRILL				
ELECTRIC OUTLET				
FIBER DROP RISER				
ONT				
PENETRATION POINT				
POLE				

PROPOSED PERPENDICULAR AERIAL CROSSING
CSX @ CHICHESTER AVE

PECO P#131

NEW VERIZON FIBER OPTIC CROSSING



PECO P#132

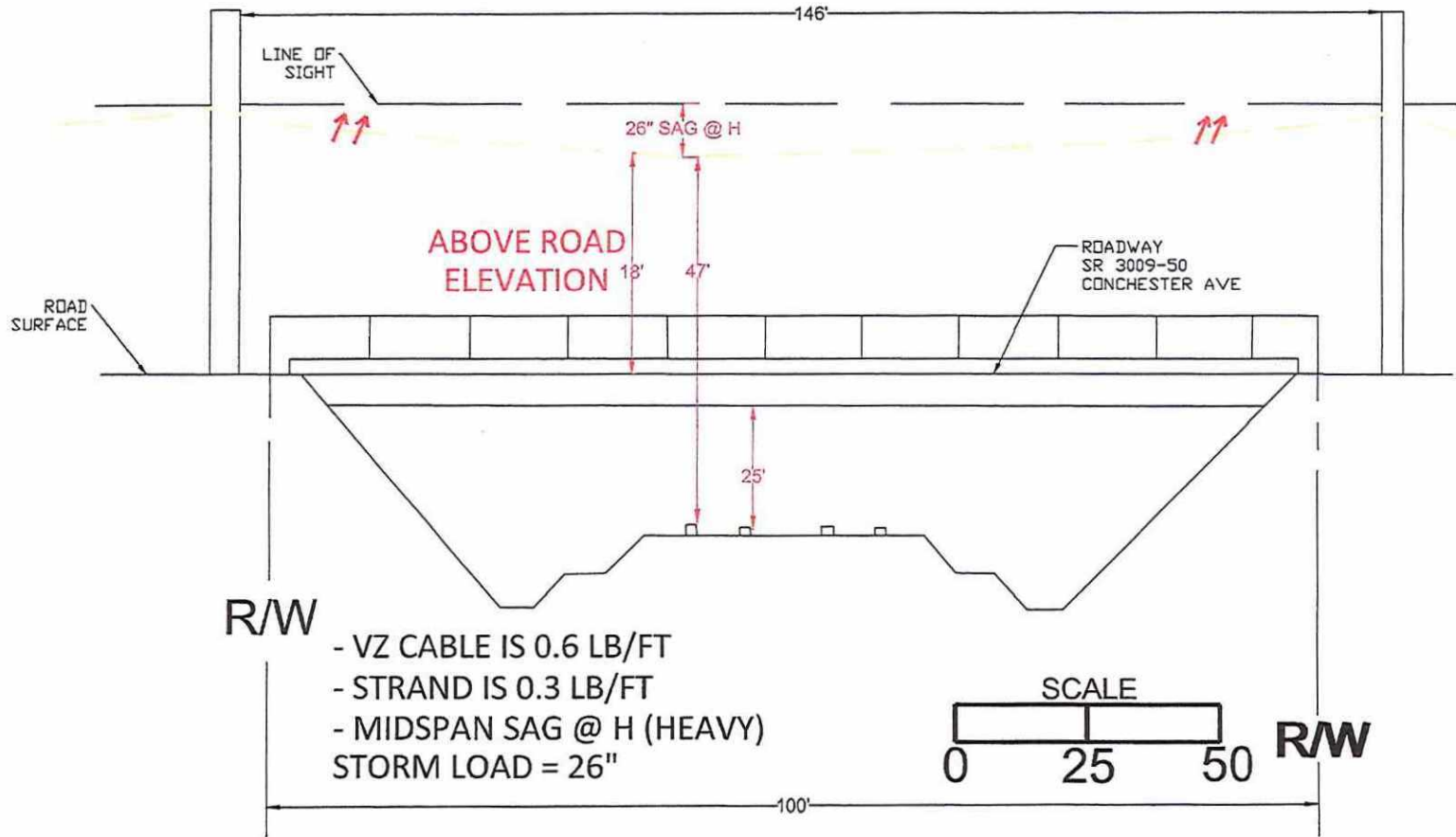

- VZ CABLE IS 0.6 LB/FT
- STRAND IS 0.3 LB/FT
- MIDSPAN SAG @ H (HEAVY)
STORM LOAD = 26"

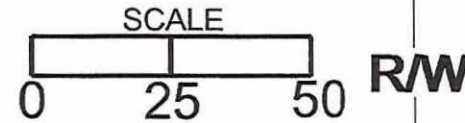

LEGEND: (PROPOSED ————), (EXISTING ————)		CORNING CLEAR TRACK SSB		STRAND	
YYY BOX	[Symbol]	[Symbol]	[Symbol]	CONDUIT	[Symbol]
COYOTE BOX	[Symbol]	[Symbol]	[Symbol]	EMT	[Symbol]
S-ONE BOX	[Symbol]	[Symbol]	[Symbol]	FIBER CABLE/FDT TAIL STUB	[Symbol]
FIBER DISTRIBUTION HUB	[Symbol]	[Symbol]	[Symbol]	FUTUREPATH	[Symbol]
FIBER DISTRIBUTION TERMINAL	[Symbol]	[Symbol]	[Symbol]	IPP/SWID	[Symbol]
HANDHOLE	[Symbol]	[Symbol]	[Symbol]	MICRODUCT	[Symbol]
MANHOLE	[Symbol]	[Symbol]	[Symbol]	PLASTIC MOLDING	[Symbol]
SLACK STORAGE BOX	[Symbol]	[Symbol]	[Symbol]	CORNING CLEAR TRACK	[Symbol]

VERIZON FTTP DETAIL ENGINEERING SURVEY	
PROPOSED PERPENDICULAR AERIAL CROSSING BOOTHWYN, PA 19013	
BUILDING CONTACT:	
WIRE CENTER: CHES-B	
CONSTRUCTION TYPE: RR PERMIT	GEO CODE:
COUNTY: UPPER CHICHESTER TWNShP	MAP: GRID:

DRAWN & ENGINEERED BY:	
740 Springdale Dr. Exton, PA 19341 www.piketelcom.org 1-508-337-7600	
WORK ORDER #:	1A6PA1P
SHEET: 1 OF 2	

04/17/2014 C:\Users\jgomez\OneDrive - Pike Enterprises, LLC\Desktop\shared\m\100\00000000\CHICHESTER AVE 4 1 30 04\PECO P#131 CHICHESTER AVE 4 1 30 04.dwg