



November 5, 2024

Rosemary Chiavetta, Secretary
Pennsylvania Public Utility Commission
400 North Street
Harrisburg, PA 17120

Re: Application of the Department of Transportation of the Commonwealth of Pennsylvania for approval to alter the public at grade crossing by the installation of new railroad warning devices and crossing surface where Crowl Toot Road (T-340) crosses the track of East Penn Railroad LLC, DOT Number 531 793 U, in Lower Oxford Township, Chester County ***all in accordance with the Federal Grade Crossing Program*** and the allocation of costs incident thereto.

Dear Secretary Chiavetta:

Enclosed for filing, please find the Application of the Department of Transportation.

A copy of this Application and Exhibits has been served upon the parties in the Certificate of Service to the Application.

Sincerely,

Abiyabebe (AA)

Abiy Abebe
District Grade Crossing Administrator 1
Engineering District 6-0
Department of Transportation

Attachments

cc: Parties of Record

Mark Chappell, P.E., Chief, Right-of-Way, Utilities, and Grade Crossing Div, 7th FL, CKB
Karen L Cummings, Senior Counsel, Office of Chief Counsel, 9th FL, CKB
William M. Sinick P.E., Supervisor, Rail Safety Engineering Section PUC, 3rd Floor, CKB

**BEFORE THE
PENNSYLVANIA PUBLIC UTILITY COMMISSION**

Application of the Department of Transportation of the Commonwealth of Pennsylvania for approval to alter the public at grade crossing by the installation of new warning devices and crossing surface, where Crawl Toot Road (T-340) crosses the track of East Penn Railroad LLC, DOT Number 531 793 U, in Lower Oxford Township, Chester County *all in accordance with the Federal Grade Crossing Program* and the allocation of cost incidental thereto.

Application
Docket No. _____

Electronically Filed

APPLICATION OF THE COMMONWEALTH OF PENNSYLVANIA, DEPARTMENT
OF TRANSPORTATION

Applicant, Commonwealth of Pennsylvania, Department of Transportation, files this Application pursuant to the provisions of 66 Pa.C.S § 2702 and 52 Pa. Code § 5.13 for the alteration of the public at grade crossing where Crawl Toot Road crosses tracks of East Penn Railroad, LLC. at DOT Number 531 793 U in Lower Oxford Township, Chester County as described below:

1. The name and address of Applicant are Commonwealth of Pennsylvania, Department of Transportation, Charles H. Davies, P.E., Assistant District Executive-Design, Engineering District 6-0, 7000 Geerdes Boulevard, King of Prussia, PA 19406-1525.

2. The name and address of attorney for the Applicant is Karen L. Cummings, Senior Counsel, Commonwealth of Pennsylvania, Department of Transportation, Office of Chief Counsel, PO Box 8212, Harrisburg, PA 17105-8212.

3. The Applicant is an agency of Commonwealth of Pennsylvania, organized and existing under the Administrative Code of 1929, 71 P.S. § 511, et seq. and generally 36 P.S. § 670 - 401 et seq., is filling this application on of behalf of Lower Oxford Township as evidenced by Resolution and Authorization letter dated June 10, 2024 which is attached hereto and marked as Exhibits “A” and Exhibit “B”.

4. The names and addresses of the persons, parties and entities concerned in, or affected by the proposed construction, to the best of the Applicant’s knowledge, are shown in the certificate of service. In addition to those served, the Applicant requests that the following also receive service of all documents in this matter:

Mark J. Chappell, P.E., Chief
Right of Way, Utilities & Grade Crossing Division
Pennsylvania Department of Transportation
PO Box 3362
Harrisburg PA 17105-3362
marchappel@pa.gov

Karen L. Cummings, Senior Counsel
Office of Chief Counsel
Pennsylvania Department of Transportation
PO Box 8212
Harrisburg PA 17105-8212
kcummings@pa.gov

5. The Applicant is seeking approval to alter Crawl Toot Road by installation of new warning devices and crossing surface. A Location Map and circuit plans are attached as Exhibit “C” and Exhibit “D” respectively.

6. The Applicant is not aware of prior Public Utility Commission orders for this crossing.

7. The average daily traffic for Lake Road East is unknown.

8. The estimated total cost for the project subject to the application and described above is \$285,734.00. The Applicant anticipates the funding for the project will be 100% federal funds.

9. This project is necessary and proper for the safety and convenience of the public.
10. A conference of all parties of interest should be held to discuss the proposed project.

Wherefore, Applicant respectfully requests that the Public Utility Commission approve this Application.

Respectfully Submitted

/s/ Charles H Davies

Charles H. Davies, P.E.
Assistant District Executive
Engineering District 6-0
Department of Transportation
7000 Geerdes Boulevard
King of Prussia, PA 19406-1525
Phone: (610) 205-6670
Fax: (610) 205-6903
Email: cdavies@pa.gov

Dated: 11/1/24

**BEFORE THE
PENNSYLVANIA PUBLIC UTILITY COMMISSION**

Application of the Department of Transportation of the Commonwealth of Pennsylvania for approval to alter the public at grade crossing by the installation of new warning devices and crossing surface, where Crowl Toot Road (T-340) crosses the track of East Penn Railroad LLC, DOT Number 531 793 U, in Lower Oxford Township, Chester County *all in accordance with the Federal Grade Crossing Program* and the allocation of cost incidental thereto.

Application
Docket No. _____

Electronically Filed

VERIFICATION

I, Abiy Abebe, Grade Crossing Administrator 1, hereby state that the facts above set forth are true and correct to the best of my knowledge, information, and belief and that I expect to be able to prove the same at a hearing held in this matter. I understand that the statements herein are made subject to the penalties of 18 Pa.C.S. §4904 (relating to unsworn falsification to authorities).

Date: 11/5/2024

Abiyabebe (AA)
Abiy Abebe
Grade Crossing Administrator 1

**BEFORE THE
PENNSYLVANIA PUBLIC UTILITY COMMISSION**

Application of the Department of Transportation of the Commonwealth of Pennsylvania for approval to alter the public at grade crossing by the installation of new warning devices and crossing surface, where Crowl Toot Road (T-340) crosses the track of East Penn Railroad LLC, DOT Number 531 793 U, in Lower Oxford Township, Chester County *all in accordance with the Federal Grade Crossing Program* and the allocation of cost incidental thereto.

Application
Docket No. _____

Electronically Filed

CERTIFICATE OF SERVICE

I hereby certify that I have this day served a true copy of the foregoing document upon the participants listed below, in accordance with the requirements of 52 Pa. Code §1.54, by electronic mail:

Alfred Sauer, President
East Penn Railroad, LLC
505 South Broad Street
Kennett Square, PA 19348
asauer@regional-rail.com

Brian O'Leary, AICP Executive Director
Chester County Planning Commission
601 Westtown Road #270
PO Box 2747
West Chester, PA 19380-0990
boleary@chesco.org

Deborah Kinney, Secretary
Lower Oxford Township
220 Township Road
Oxford, PA 19363
loweroxfordtwp@zoominternet.net

Ken Babbittin
London Grove Township
372 Rose Hill Road, Suite 100
West Grove, PA 19390
Kbattin@londongrove.org

John Schaible, Public Works Supervisor
Oxford Borough
1 Octoraro Alley
PO Box 380
Oxford, PA 19363-0380
publicworks@oxfordboro.org

Joel Sheep, Project Coordinator
Armstrong Utilities
122 South Queen Street
Rising Sun, MD 21911
jsheep@agoc.com

Mike Kimberly, Construction Coordinator
Comcast Cable Communications
190 Shoemaker Road
Pottstown, PA 19464
mike_kimberly@cable.comcast.com

Lauren Levitt, Supervisor Network Construction
Crown Castle Fiber
3200 Horizon Drive - Suite 150
King of Prussia, PA 19406
Lauren.Levitt@crowncastle.com

Keith Johnston, Construction Supervisor
Chester Water Authority
415 Welsh Street
PO Box 467
Chester, PA 19013
kmjohnston@chesterwater.com

Dave Morris, Network Engineer
Frontier Communications
93 Old Berwick Road
Drums, PA 18222
dave.morris@ftr.com

David Busch, Executive Director
Oxford Area Sewer Authority
2196 Baltimore Pike
Oxford, PA 19363-4021
davidbusch@oxfordsewer.org

Pete Dettling, Program Manager
PECO Energy Company
1050 West Swedesford Road
Berwyn, PA 19312
Charles.Dettling@exeloncorp.com

Phillip Deater, Senior OSP Engineer
United Federal Data of PA, LLC
210 York Street - Suite 200
York PA 17403
phillip@ufd.com

Kurt Zielaskowski
UGI Utilities, Inc.
225 Morgantown Road
Reading, PA 19611
kzielaskowski@ugi.com

Scott Nubbemeyer, Highway Engineer
Verizon Pennsylvania, LLC
1050 Virginia Drive
Fort Washington, PA 19034
scott.nubbemeyer@verizon.com

Logan Harper
Columbia Gas of PA
1600 Colony Road
York, PA 17408
Lharper@nisource.com

Dated this 5th Day of November, 2024

Abiyabebe (AA)

Abiy Abebe

**Lower Oxford Township
Commonwealth of Pennsylvania**

Resolution No. 2024-15

**A RESOLUTION AUTHORIZING PENNDOT TO REQUEST INSTALLATION OF RAILROAD WARNING
DEVICES WHERE CROWL TOOT ROAD (T-340) CROSSES AT-GRADE THE TRACK OF
EAST PENN RAILROAD, LLC**

WHEREAS, Crowl Toot Road (T-340) is a public roadway under the jurisdiction of the Lower Oxford Township, and;

WHEREAS, a railroad operates through the Lower Oxford Township, which railroad maintains a crossing over Crowl Toot Road (T-340); and

WHEREAS, in order for the improvements to the Crowl Toot Road (T-340) to be made pertaining to the railroad crossing, such improvements must be submitted to the Pennsylvania Public Utility Commission (PUC) by and through the Pennsylvania Department of Transportation (PennDOT).

NOW THEREFORE BE IT RESOLVED, by the Board of Supervisors of Lower Oxford Township, Chester County, Pennsylvania, as follows:

1. PennDOT is authorized on behalf and for the Board of Supervisors to request approval of the PUC to install appropriate warning devices at the Railroad Crossing at Crowl Toot Road (T-340) railroad crossing in the Lower Oxford Township.
2. PennDOT is authorized on behalf, and for the Board of Supervisors, to issue Notice-To-Proceed letters to the railroad for improvements at the railroad crossing at Crowl Toot Road (T-340) in Lower Oxford Township, Chester County, Pennsylvania.

Adopted and approved this 10th day of June 2024.

ATTEST:

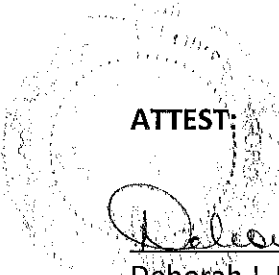
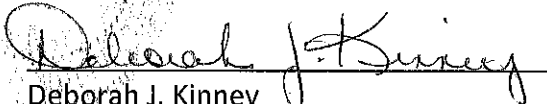

Deborah J. Kinney
Secretary/Treasurer

**BOARD OF SUPERVISORS OF
LOWER OXFORD TOWNSHIP**

Kevin R. Martin, Chairman

Noël A. Roy, Vice-Chairman

Robert J. McMahon, Member

Exhibit A

Page 1 of 1



May 15, 2024

Deborah J. Kinney, Secretary
Lower Oxford Township
220 Township Road
Oxford PA 19363

Re: Chester County
Lower Oxford Township
At-grade RR Crossings
Crowl Toot Road RR crossings
DOT # 531 793 U
MPMS # 118189

Dear Ms. Deborah J. Kinney:

As you may be aware, the Commonwealth of Pennsylvania, Department of Transportation (the Department) is filing an application with the Pennsylvania Public Utility Commission (PUC) for the approval to install a railroad warning devices where Crowl Toot Rd (T-340) crosses at-grade the track of Penn East Railroad LLC. (DOT # 531 793 U), located in Lower Oxford Township County.

This action is in accordance with the Section 130 Federal Rail Safety Program, which provides 100 percent Federal funding for the construction of railroad warning devices on public roads. The railroad will seek reimbursement from the Department for 100 percent of the construction costs.

Please sign, date, and affix the (*Municipality*) seal at the space provided on this letter and return the original to the District office. Please also provide a resolution agreeing to allow the Department to file this application on your behalf and authorizing the Department to issue Notice-to-Proceed letters to the railroad for design and/or construction. If a resolution is not provided, it will be presumed that, by signature, date, and seal of this letter, you concur with these conditions and authority is granted, and no resolution is necessary.

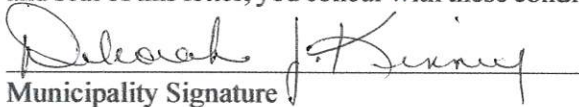

Municipality Signature

6/10/24
Date

As a result of this action, the municipality will receive a copy of the application that will be made by the Department to the PUC, which will then be followed by a letter from the PUC advising of a subsequent field conference at the crossing. Should there be any questions with regards to this matter, please call me at 610-205-6530, or call Abiy Abebe, Railroad Administrator I, at 610-205-6535.

Sincerely,
/s/ Mary Ann Lang
Mary Ann Lang
Engineering District 6-0 Utility Manager
Department of Transportation

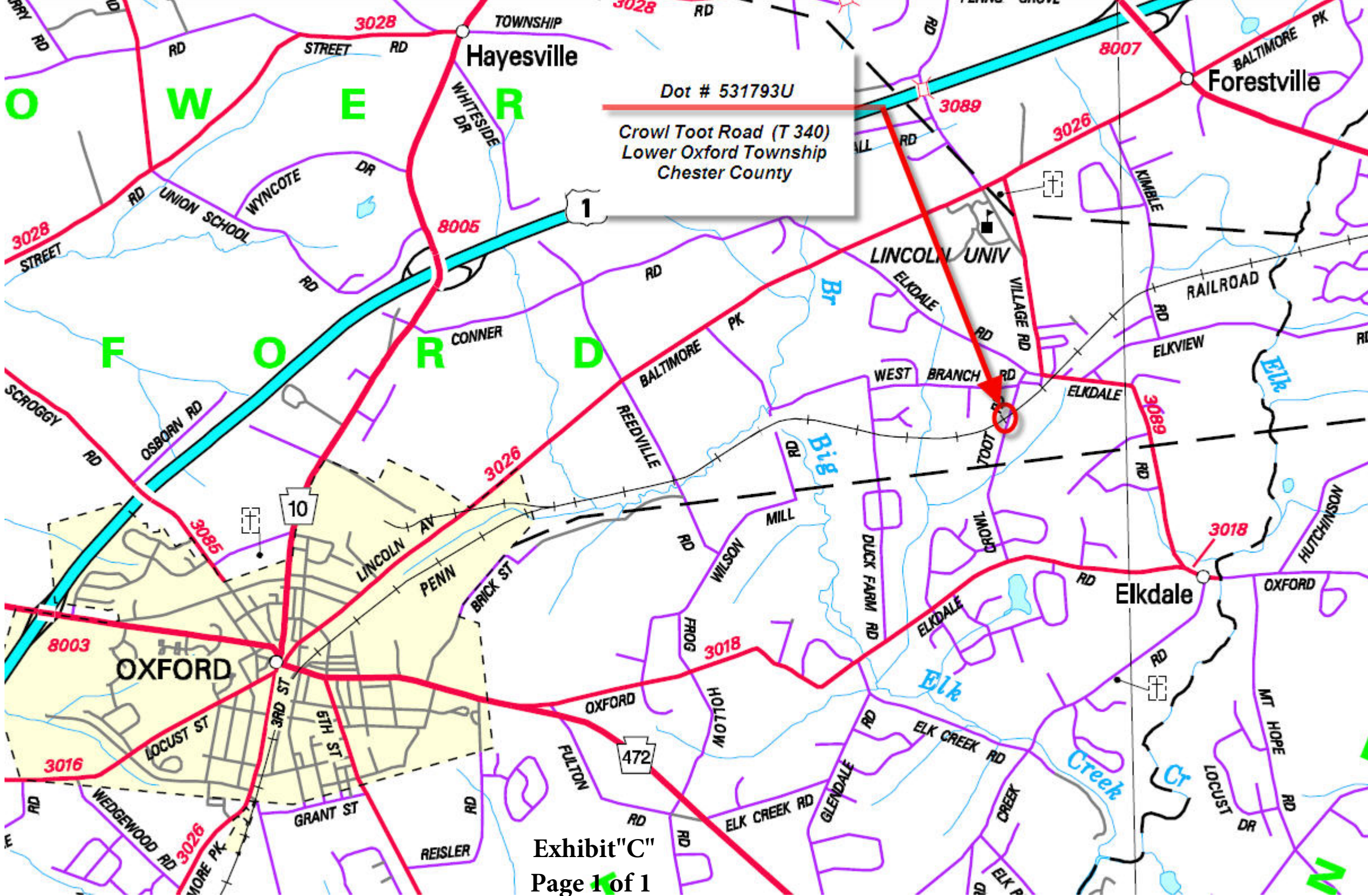
File: MPMS #s 118189



Dot # 531793U
Crowl Toot Road (T 340)
Lower Oxford Township
Chester County

WEST ←

→ EAST

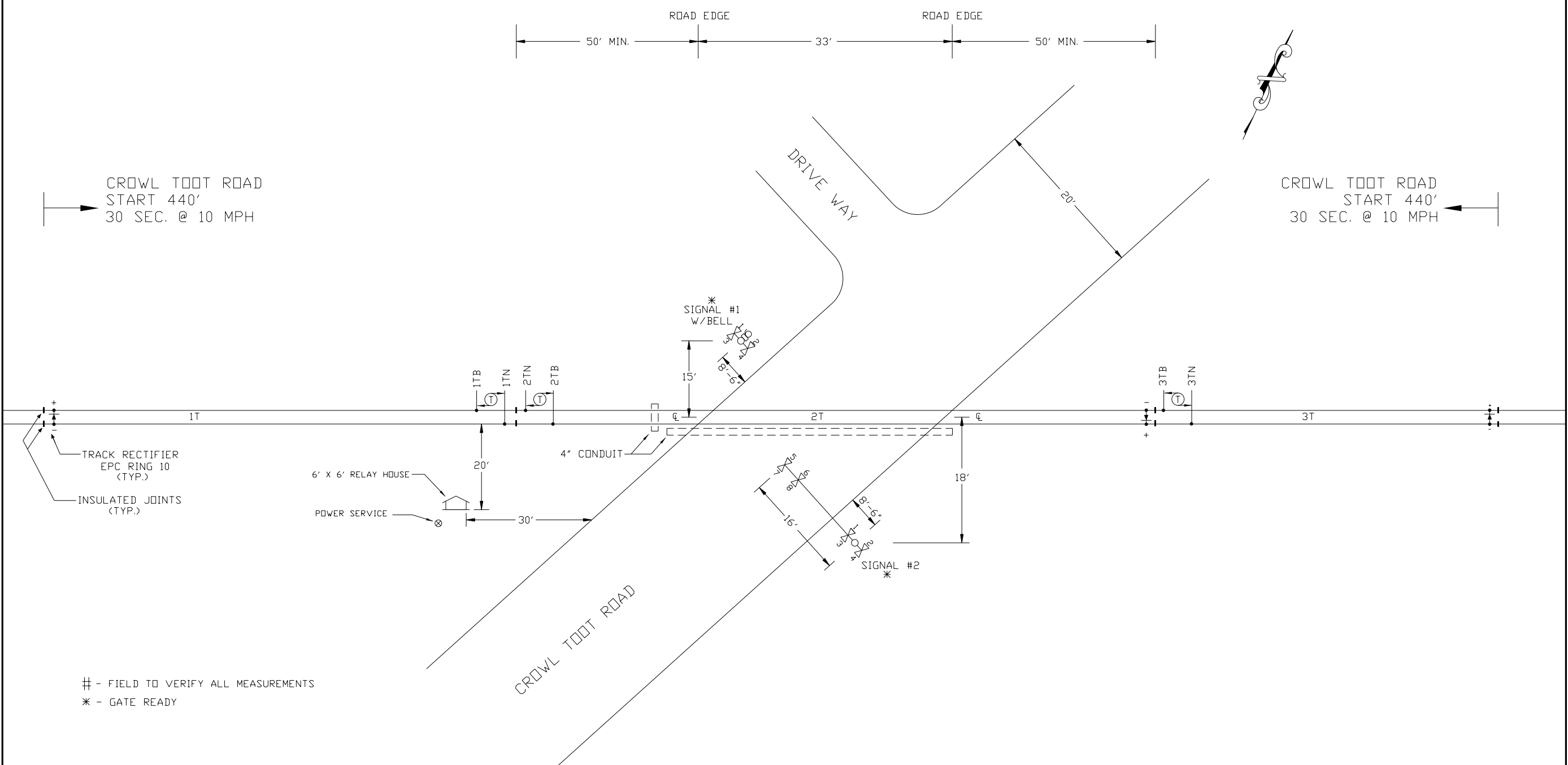

- FIELD TO VERIFY ALL MEASUREMENTS
 * - GATE READY

NOTES:

- MATERIAL & INSTALLATION TO BE IN ACCORDANCE WITH MUTCD, STATE AND RAILROAD STANDARDS.
- ALL DIMENSIONS ARE APPROXIMATE AND MAY VARY DUE TO ACTUAL FIELD CONDITIONS.
- ALL FLASHING LIGHT SIGNALS TO BE LIGHT EMITTING DIODE (LED)
- Ⓢ DENOTES TWIST PAIR.
- ISLAND CIRCUIT MUST BE A MINIMUM OF 120' IN LENGTH

CABLE RUN TABULATION

HOUSE TO SIGNAL #1 (GATE READY)	- 7/C #6 UG CABLE
	- 7/C #14 UG CABLE
HOUSE TO SIGNAL #2 (GATE READY)	- 7/C #6 UG CABLE
	- 7/C #14 UG CABLE
HOUSE TO AC SERVICE	- 3/C #6 UG CABLE
HOUSE TO 1TN & 1TB	- 2/C #6 TW. PAIR UG CABLE
HOUSE TO 2TN & 2TB	- 2/C #6 TW. PAIR UG CABLE
HOUSE TO 3TN & 3TB	- 2/C #6 TW. PAIR UG CABLE

Exhibit "D"

Page 1 of 7

SHEET 1 OF 7

DIAMONDBACK SIGNAL (410) 795-9601 5965 EXCHANGE DRIVE SUITE "D" SYKESVILLE, MD 21784	AS WIRED XX/XX/XXXX		AS INSTALLED XX/XX/XXXX	
	EAST PENN RAILROAD RAILROAD CROSSING WARNING DEVICES			
	SCALE: NONE	APPROVED BY:	DRAWN BY: NST	
	DATE: 08/02/24	REVISI:	CROWL TOOT ROAD DOT # 531 793U MP. 45.92 OXFORD, CHESTER COUNTY, PA	
TRACK & CABLE PLAN			DRAWING NUMBER	

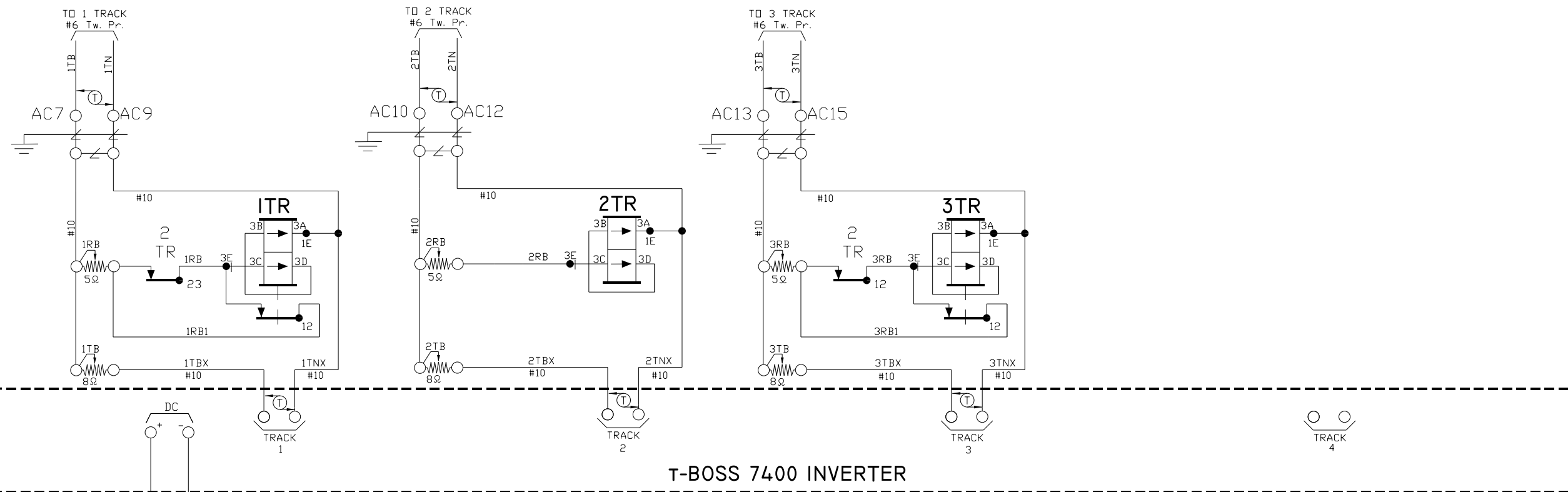

WARNING
 PLACING SWITCH TO THE
 OUT-OF-SERVICE POSITION
 COMPLETELY DISABLES THIS HIGHWAY
 CROSSING WARNING SYSTEM. PROPER
 AUTHORITIES MUST BE NOTIFIED
 PRIOR TO OUT-OF-SERVICE.

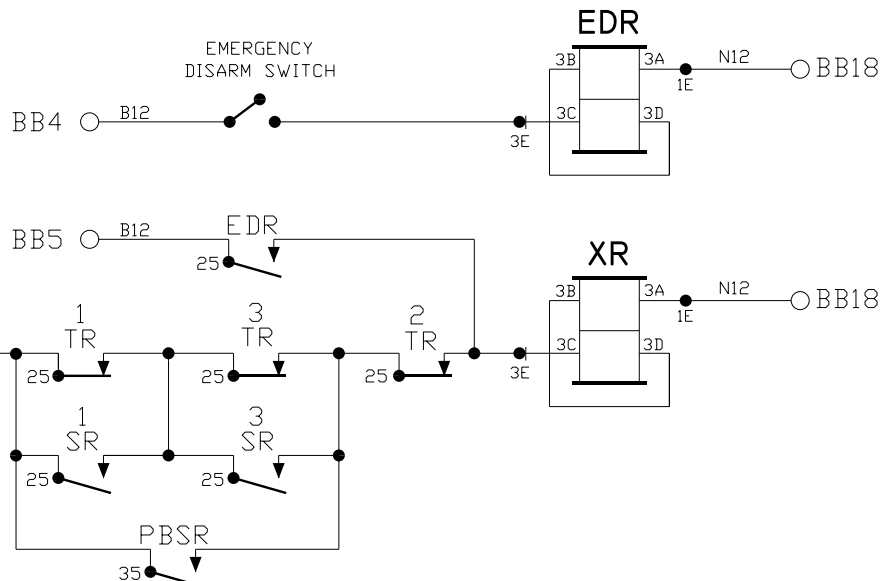
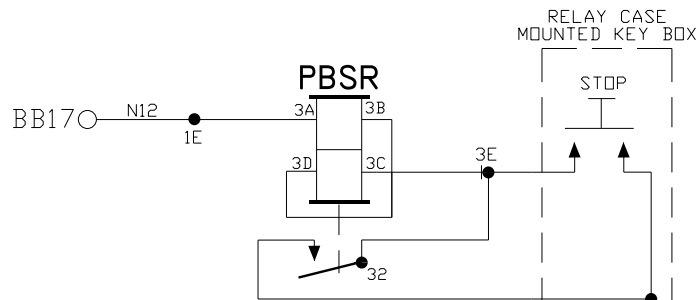

SLT-000
 STICK RELEASE TIMER
 (10 MINUTES)

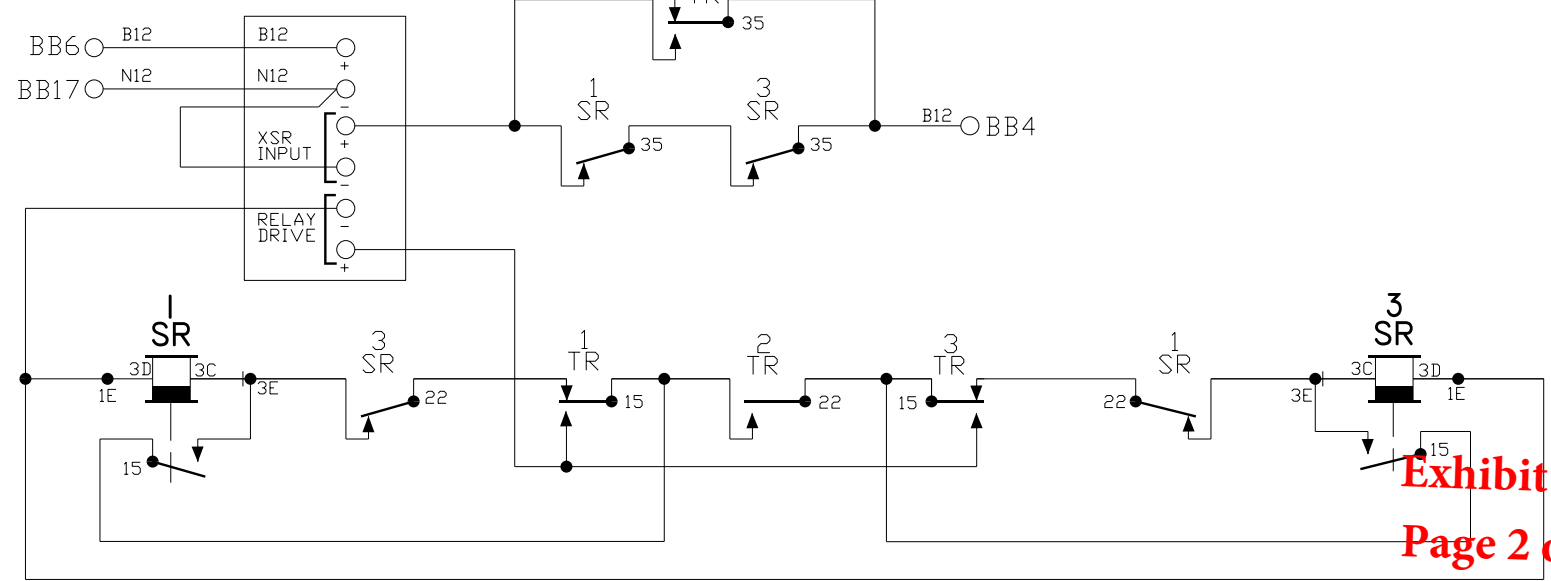

- NOTES:
1. ALL WIRE THIS SHEET IS #14 AWG FLEX UNLESS OTHERWISE NOTED.
 2. DENOTES TWISTED PAIR.

AS WIRED XX/XX/XXXX AS INSTALLED XX/XX/XXXX

DIAMONDBACK SIGNAL
 (410) 795-9601
 5965 EXCHANGE DRIVE
 SUITE "D"
 SYKESVILLE, MD
 21784

EAST PENN RAILROAD RAILROAD CROSSING WARNING DEVICES		
SCALE: NONE	APPROVED BY:	DRAWN BY: NST
DATE: 08/02/24		REVISED:
CROWL TOOT ROAD DOT # 531 793U MP. 45.92 OXFORD, CHESTER COUNTY, PA		
CIRCUIT PLAN "A"		DRAWING NUMBER

Exhibit "D"
Page 2 of 7

E

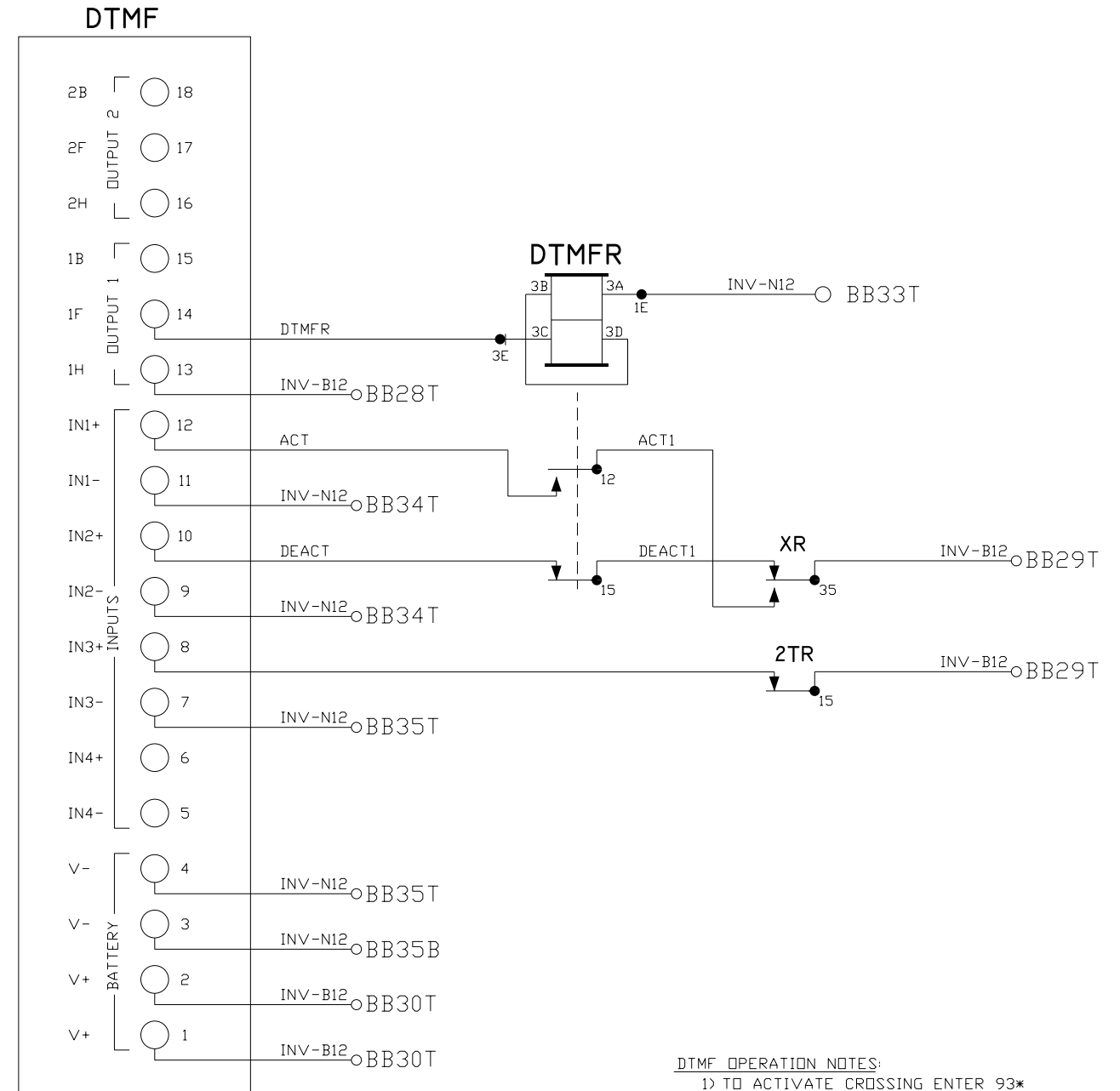

NOTE:
 1. ALL WIRE THIS SHEET IS #14 AWG FLEX UNLESS OTHERWISE NOTED.

Exhibit "D"
Page 3 of 7

SHEET 3 OF 7

AS WIRED XX/XX/XXXX AS INSTALLED XX/XX/XXXX

DIAMONDBACK SIGNAL		EAST PENN RAILROAD RAILROAD CROSSING WARNING DEVICES	
SCALE: NONE	APPROVED BY:	DRAWN BY: NST	
DATE: 08/02/24		REVISED:	
(410) 795-9601 5965 EXCHANGE DRIVE SUITE "D" SYKESVILLE, MD 21784		CROWL TOOT ROAD DOT # 531 793U MP. 45.92 OXFORD, CHESTER COUNTY, PA	
CIRCUIT PLAN "B"		DRAWING NUMBER	

GATE NO. 1

GATE NO. 2

CONTACT	CLOSED	FUNCTION	TENSION
1B	75-90°	POWER DOWN	18-22 OZ.
1F	0-70°	SNUB DOWN	18-22 OZ.
2	0-86°	POWER UP	18-28 OZ.
3	0-10°	GATE DOWN	16-24 OZ.
4	82-90°	GATE CLEAR	16-24 OZ.
5	10-90°	BELL	16-24 OZ.
6	SPARE	SPARE	16-24 OZ.
7	0-10°	SNUB	16-24 OZ.

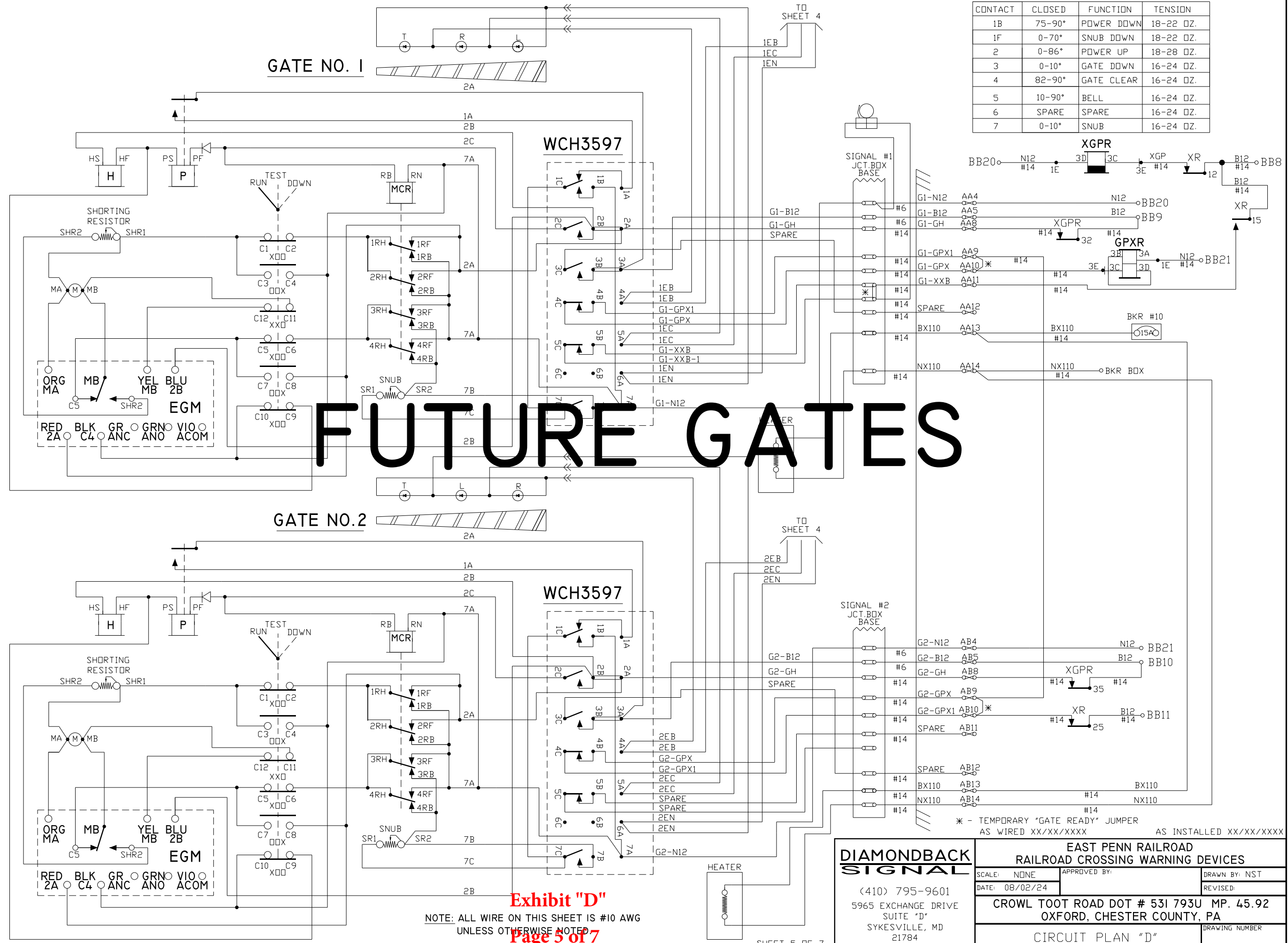

FUTURE GATES

Exhibit "D"

NOTE: ALL WIRE ON THIS SHEET IS #10 AWG UNLESS OTHERWISE NOTED

Page 5 of 7

DIAMONDBACK SIGNAL
 (410) 795-9601
 5965 EXCHANGE DRIVE
 SUITE "D"
 SYKESVILLE, MD 21784

EAST PENN RAILROAD RAILROAD CROSSING WARNING DEVICES		
SCALE: NONE	APPROVED BY:	DRAWN BY: NST
DATE: 08/02/24		REVISED:
CROWL TOOT ROAD DOT # 531 793U MP. 45.92 OXFORD, CHESTER COUNTY, PA		DRAWING NUMBER
CIRCUIT PLAN "D"		

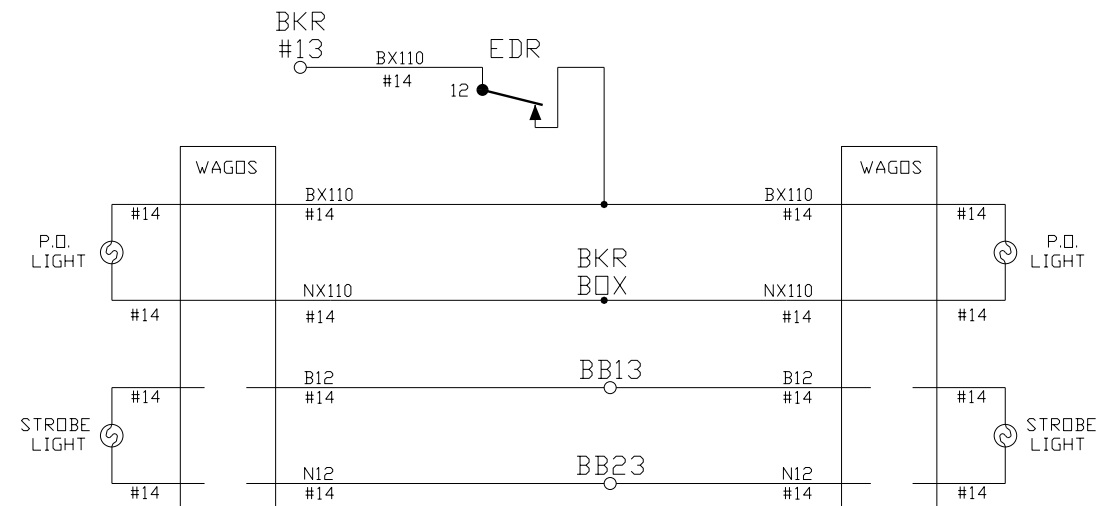
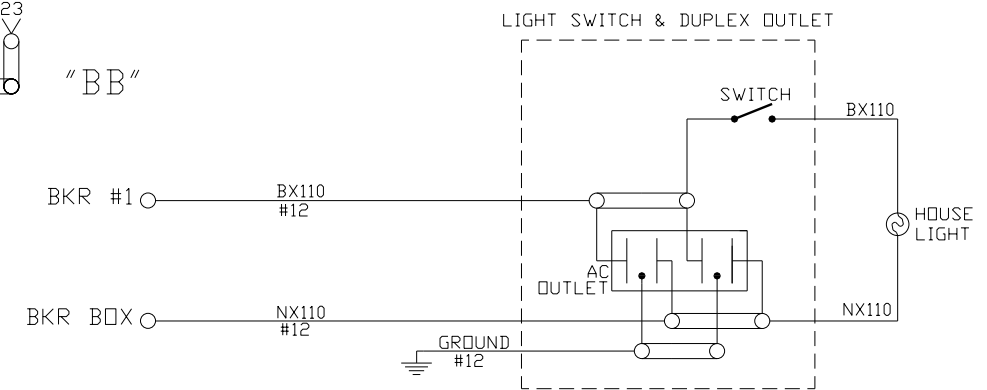
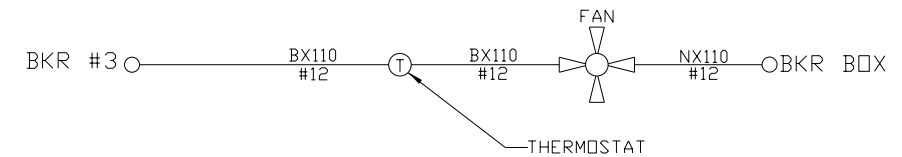
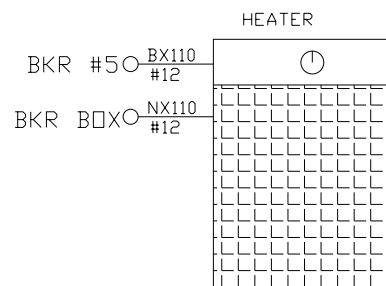
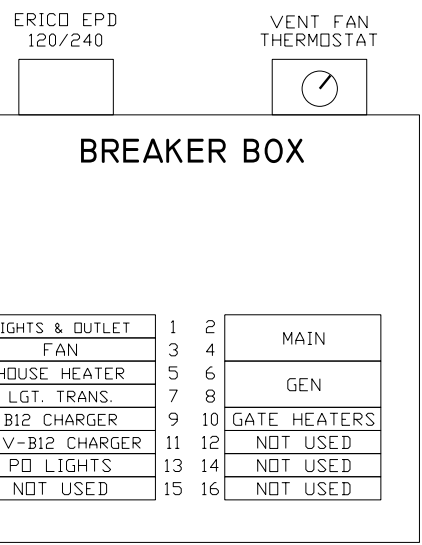
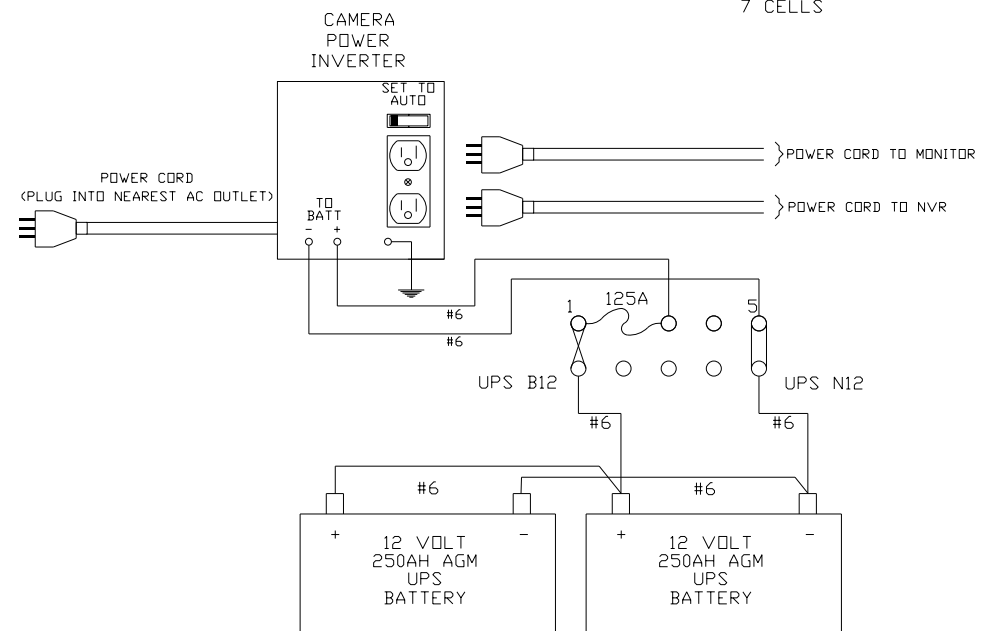
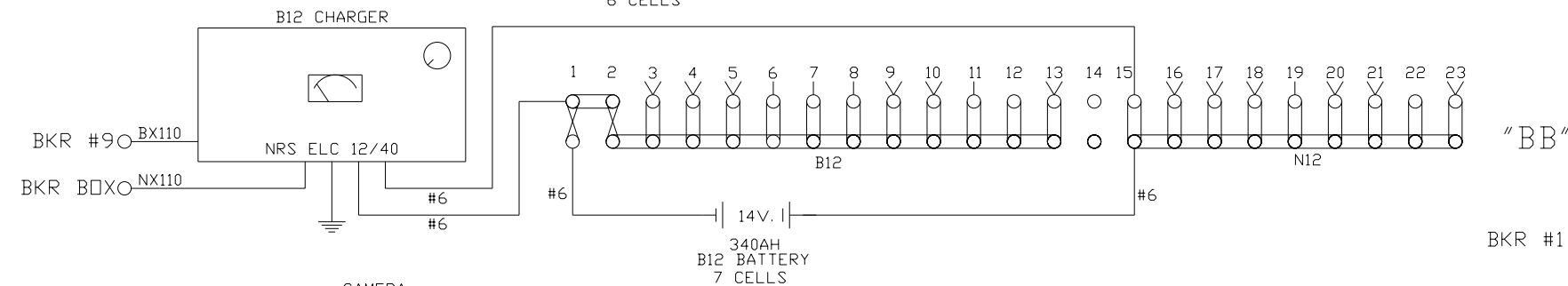
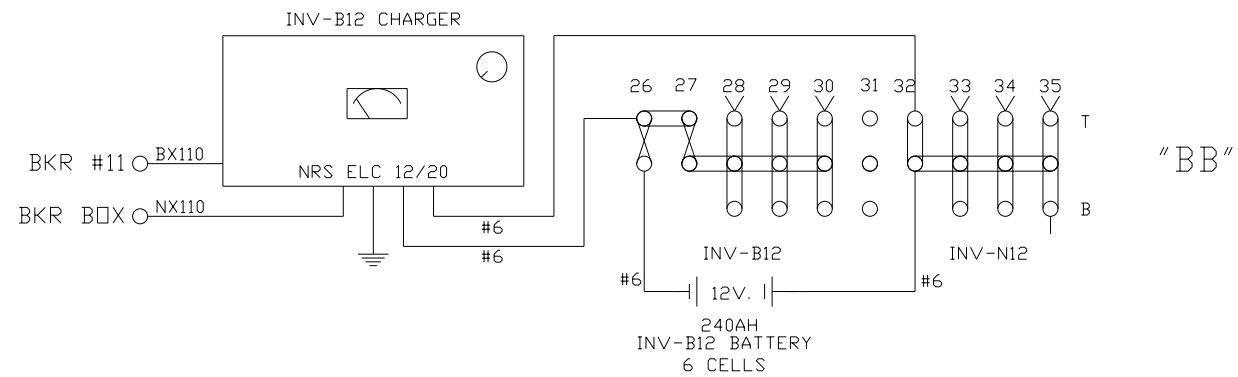

NOTE:
ALL WIRE THIS SHEET IS #10 AWG FLEX
UNLESS OTHERWISE NOTED.

AS WIRED XX/XX/XXXX AS INSTALLED XX/XX/XXXX

DIAMONDBACK SIGNAL (410) 795-9601 5965 EXCHANGE DRIVE SUITE "D" SYKESVILLE, MD 21784	EAST PENN RAILROAD RAILROAD CROSSING WARNING DEVICES	
	SCALE: NONE DATE: 08/02/24	APPROVED BY:
CROWL TOOT ROAD DOT # 531 793U MP. 45.92 OXFORD, CHESTER COUNTY, PA		DRAWING NUMBER

Exhibit "D"
Page 6 of 7

SIDE "C"

SIDE "A"

SIDE "B"

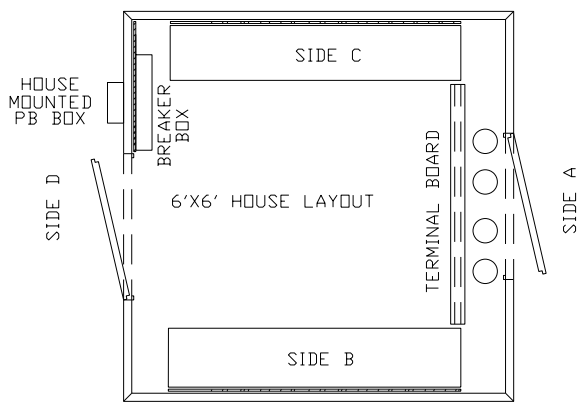
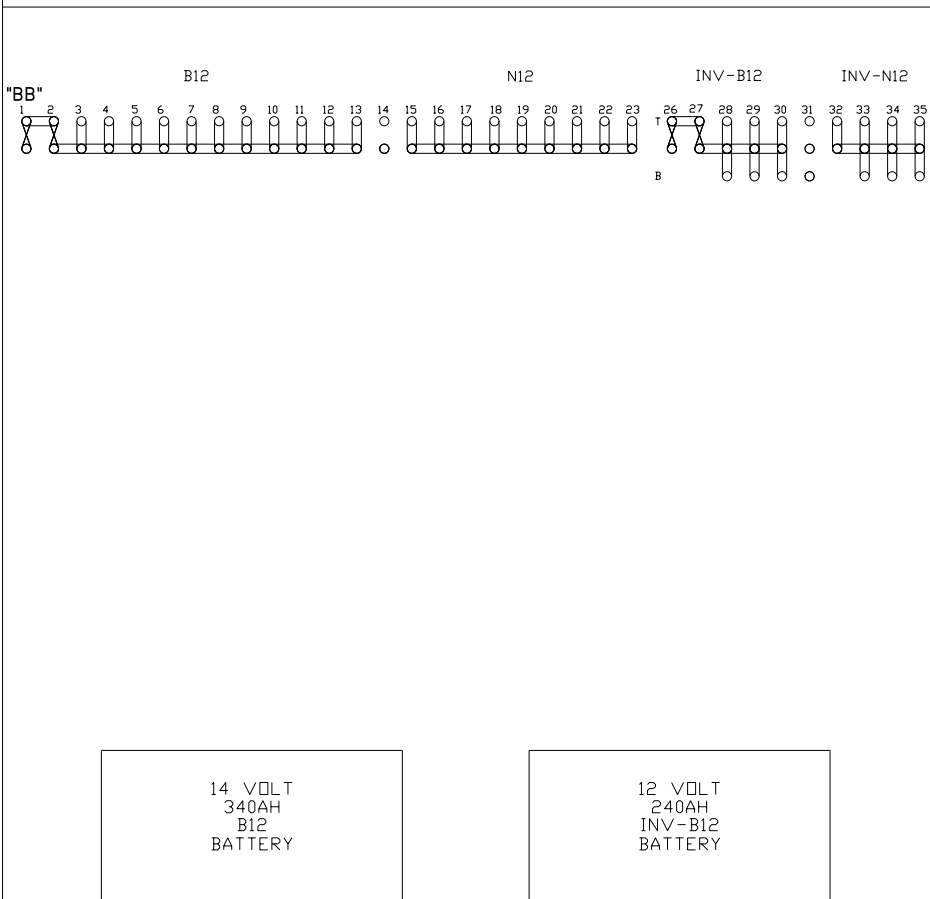
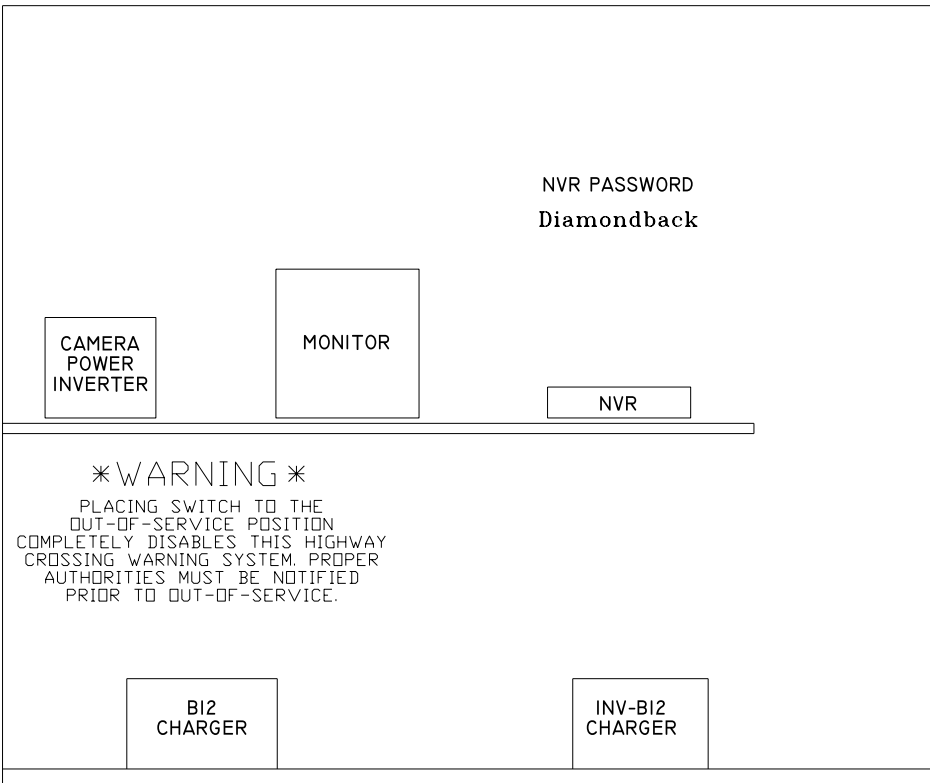
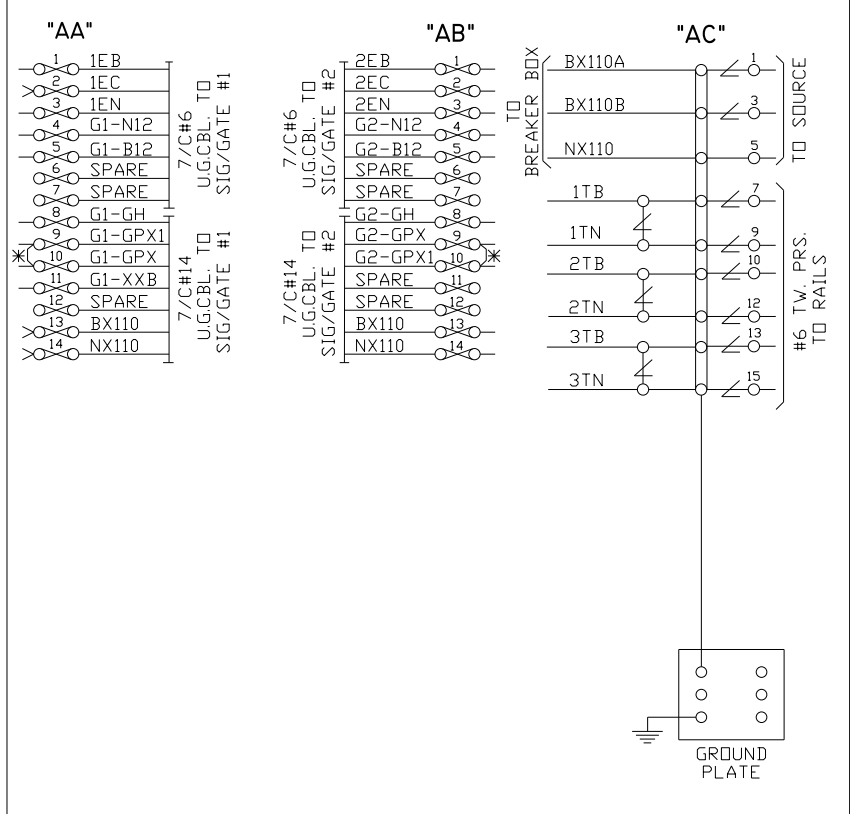
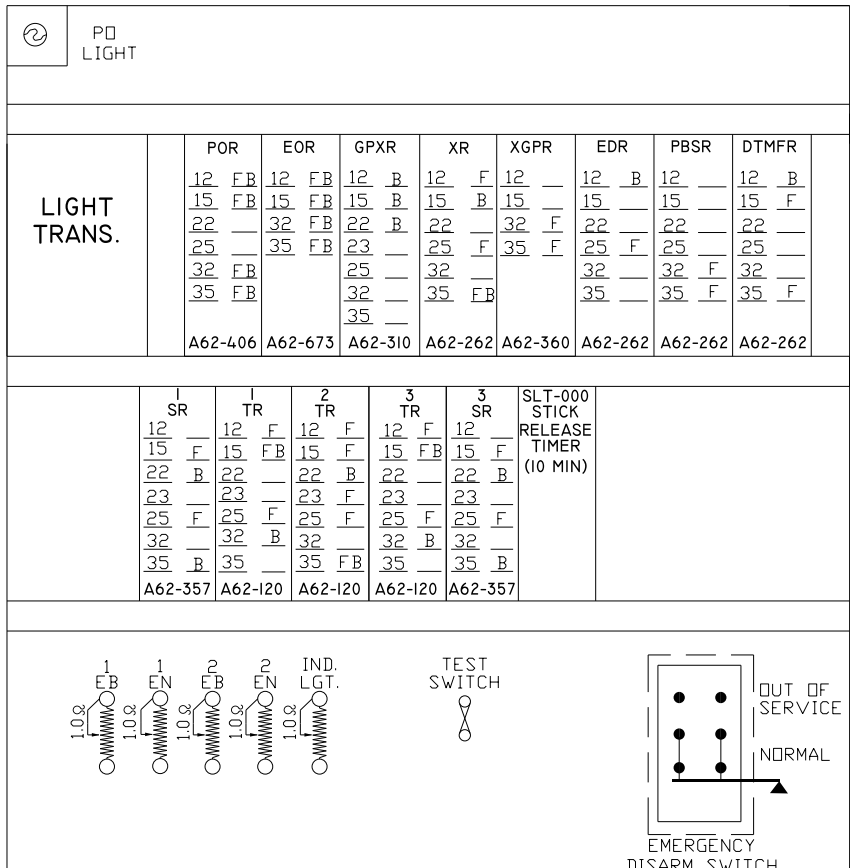
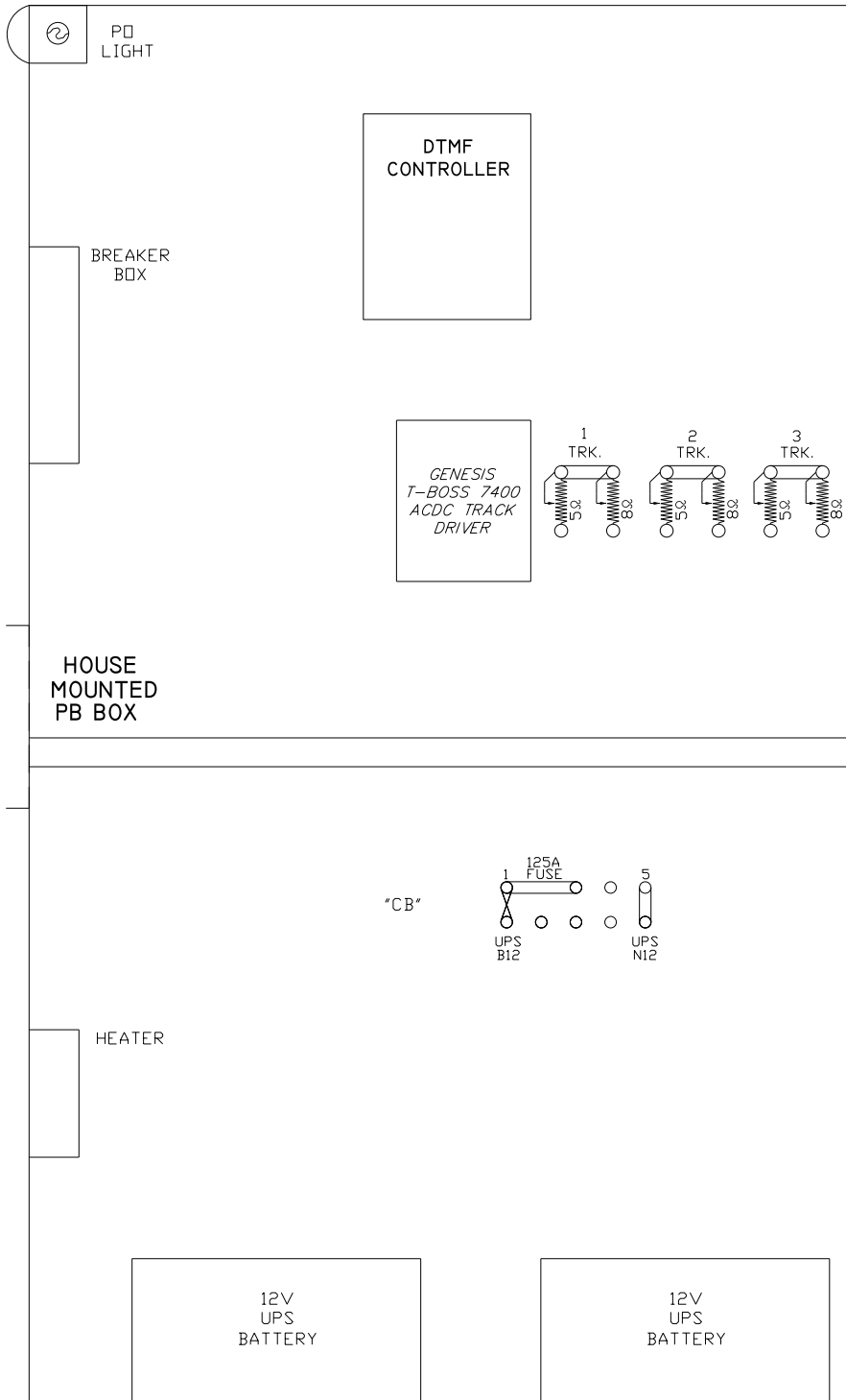

Exhibit "D"
Page 7 of 7

* - TEMPORARY "GATE READY" JUMPER

AS WIRED XX/XX/XXXX AS INSTALLED XX/XX/XXXX

DIAMONDBACK SIGNAL

(410) 795-9601
5965 EXCHANGE DRIVE
SUITE "D"
SYKESVILLE, MD
21784

**EAST PENN RAILROAD
RAILROAD CROSSING WARNING DEVICES**

SCALE: NONE APPROVED BY: DRAWN BY: NST
DATE: 08/02/24 REVISED:

**CROWL TOOT ROAD DOT # 531 793U MP. 45.92
OXFORD, CHESTER COUNTY, PA**

RELAY HOUSE LAYOUT DRAWING NUMBER