

Joey T. Chen
Corporate Counsel

Cell Phone (443) 683-1765
Fax (330) 315-9657
jchen@firstenergycorp.com

February 6, 2025

VIA ELECTRONIC FILING

Rosemary Chiavetta, Secretary
Pennsylvania Public Utility Commission
Commonwealth Keystone Building
400 North Street, Second Floor
Harrisburg, Pennsylvania 17120

**Re: Joint Letter of Notification of Keystone Appalachian Transmission Company and FirstEnergy Pennsylvania Electric Company for the Grand Point-Guilford 138 Kilovolt Transmission Line Tap to Cider Press Substation Project in Guilford Township, Franklin County, Pennsylvania
Docket No. _____**

Dear Secretary Chiavetta:

Enclosed for filing on behalf of FirstEnergy Pennsylvania Electric Company ("FE PA") is a duplicate of the Joint Letter of Notification ("LON"), previously filed on behalf of Keystone Appalachian Transmission Company ("KATCo") on February 5, 2025, requesting approval for the Grand Point-Guilford 138 Kilovolt ("kV") Transmission Line Tap to Cider Press Substation Project ("Project"). This LON is filed pursuant to the Pennsylvania Public Utility Commission's ("Commission") regulations at 52 Pa. Code § 57.72(d). Copies of this LON or a Notice of Filing have been served upon the parties as required by 52 Pa. Code § 57.74 and noted in the attached Certificate of Service. FE PA requests that one filing fee be counted for both dockets.

FE PA joins KATCo in respectfully requesting Commission review and approval of the LON on or before the April 10, 2025 Public Meeting in order to allow construction to commence immediately thereafter.

If you have any questions pertaining to this matter, please do not hesitate to contact me.

Very truly yours,



Joey T. Chen
Attorney ID #334709
76 South Main St
Akron, OH 44308
(610) 921-6784
Email: jchen@firstenergycorp.com

Enclosures

cc: Deb Backer - Bureau of Technical Utility Services (via electronic service)
Jordan Van Order - Bureau of Technical Utility Services (via electronic service)

**BEFORE THE
PENNSYLVANIA PUBLIC UTILITY COMMISSION**

JOINT LETTER OF NOTIFICATION :
FILING OF KEYSTONE :
APPALACHIAN TRANSMISSION :
COMPANY AND FIRSTENERGY :
PENNSYLVANIA ELECTRIC COMPANY : **Docket No. _____**
FOR THE GRAND POINT- :
GUILFORD 138 KILOVOLT :
TRANSMISSION LINE TAP TO :
CIDER PRESS SUBSTATION :
PROJECT IN GUILFORD :
TOWNSHIP, FRANKLIN COUNTY, :
PENNSYLVANIA :

**JOINT LETTER OF NOTIFICATION FILING OF KEYSTONE APPALACHIAN
TRANSMISSION COMPANY AND FIRSTENERGY PENNSYLVANIA ELECTRIC
COMPANY REQUESTING APPROVAL FOR THE GRAND POINT-
GUILFORD 138 KILOVOLT TRANSMISSION LINE TAP TO CIDER
PRESS SUBSTATION PROJECT**

To the Pennsylvania Public Utility Commission:

Pursuant to 52 Pa. Code § 57.72(d)(1)(i), (iii) and (vi), Keystone Appalachian Transmission Company (“KATCo”) and FirstEnergy Pennsylvania Electric Company (“FE PA”) (together, the “Companies”) jointly submit this Letter of Notification (“LON”) requesting that the Pennsylvania Public Utility Commission (“Commission”) approve the Grand Point-Guilford 138 Kilovolt (“kV”) Transmission Line Tap to Cider Press Substation Project (“Project”) as described herein.

In support thereof, the Companies submit as follows:

1. KATCo, a subsidiary of FirstEnergy Corp. (“FirstEnergy” or “FE”), is a public utility that provides interstate electric transmission service in the Commonwealth subject to the jurisdiction of the Federal Energy Regulatory Commission.

2. KATCo has been issued a certificate of public convenience to operate as a Pennsylvania public utility pursuant to this Commission’s Opinion and Order entered December 7, 2023, at Docket Nos. A-2023-3038771 et al.¹ Accordingly, KATCo is subject to the Commission’s jurisdiction over the siting and construction of transmission lines pursuant to Chapter 57, Subchapter G, of the Commission’s regulations. *See* 52 Pa. Code §§ 57.71 – 57.77.

3. FE PA is a public utility and wholly owned subsidiary of FirstEnergy that provides transmission and distribution service to about 2,108,000 electric utility customers within approximately 32,400 square miles across the Commonwealth of Pennsylvania. FE PA is subject to the jurisdiction of this Commission over the siting and construction of transmission lines pursuant to Chapter 57, Subchapter G, of the Commission’s regulations. *See* 52 Pa. Code §§ 57.71 – 57.77.

4. The addresses of KATCo’s and FE PA’s principal business offices are, respectively:

Keystone Appalachian Transmission Company
76 South Main Street
Akron, OH 44308

FirstEnergy Pennsylvania Electric Company
800 Cabin Hill Drive
Greensburg, PA 15601

¹ *See Joint Application of Metropolitan Edison Company, Pennsylvania Electric Company, Pennsylvania Power Company, West Penn Power Company, Keystone Appalachian Transmission Company, Mid-Atlantic Interstate Transmission, LLC, and FirstEnergy Pennsylvania Electric Company for All of the Necessary Authority, Approvals, and Certificates of Public Convenience, Docket Nos. A-2023-3038771, et al.*

5. KATCo and FE PA are jointly represented in this matter by the following attorney, who is authorized to receive notices and communications on the Companies' behalf:

Joey T. Chen
Attorney ID #334709
FirstEnergy Service Company
76 South Main St.
Akron, OH 44308
(610) 921-6784
Email: jchen@firstenergycorp.com

KATCo and FE PA agree to accept electronic service in this proceeding.

6. KATCo and FE PA also request that a copy of all notices and communications regarding this matter be sent to:

Colin Nahill
Transmission Specialist II
FirstEnergy Service Company
2800 Pottsville Pike
Reading, PA 19612
Email: cnahill@firstenergycorp.com

7. KATCo and FE PA provide the following attached exhibits in support of this Letter of Notification:

- **Exhibit 1:** a topographic map depicting the general location of the proposed Project;
- **Exhibit 2:** a depiction of the general layout of the Project;
- **Exhibit 3:** a depiction of the general configuration for a 138 kV single circuit steel 2000A horizontal double pole switch structure;
- **Exhibit 4:** a depiction of the general configuration for a 138 kV single circuit steel vertical single pole tap structure;
- **Exhibit 5:** a depiction of the general configuration for a 138 kV single circuit steel 2000A vertical single pole switch structure;
- **Exhibit 6:** a copy of the PJM Interconnection, LLC ("PJM") Sub-Regional Transmission Expansion Plan ("RTEP") Committee April 19, 2024 Need Meeting Presentation Slide;
- **Exhibit 7:** a copy of the PJM RTEP Committee May 17, 2024 Solution

Meeting Presentation Slide;

- **Exhibit 8:** a copy of the Waters Delineation Report prepared by Civil & Environmental Consultants, Inc., dated July 2024;
- **Exhibit 9:** a copy of the Pennsylvania Natural Diversity Inventory review receipt, dated July 22, 2024; and
- **Exhibit 10:** a copy of the Pennsylvania State Historic Preservation Office clearance letter, dated July 26, 2024.

8. For this Project, FE PA has requested that KATCo provide a new 138 kV retail delivery point, so that FE PA can, in turn, provide retail electric service to a new substation owned by FE PA's end customer, Martin's Famous Pastry Shoppe, Inc. ("Martin's or "End Customer"). The proposed, new 138 kV delivery point to Martin's proposed Cider Press Substation is designed to meet their additional load request of approximately 11 MVA to support a new glass production facility. The Project is located in Guilford Township, Franklin County, Pennsylvania. A depiction of the general location of the Project is attached as **Exhibit 1**.

9. For this Project, the Companies propose to construct an approximately 0.08-mile (425 feet) transmission line tap extension from KATCo's existing Grand Point-Guilford 138 kV Transmission Line to the End Customer's proposed Cider Press Substation. A depiction of the general layout of the Project is attached and referenced herein as **Exhibit 2**.

10. To accommodate this service need, KATCo proposes to tap the circuit between existing Structures #30 and #31, both of which are 2-pole wood H-frame structures approximately 66-70 feet in height. KATCo will modify the existing Grand Point-Guilford 138 kV Transmission Line as outlined in Paragraph 11 below and extend the transmission line from the tap structure, Structure #31B, to a new transmission point of interconnection ("POI #1) with FE PA located at Structure #31B-1. KATCo will own the newly installed facilities along the existing transmission line to POI #1. FE PA will own the line extension from POI #1 to a second point of interconnection

(POI #2) with the End Customer located at Cider Press Substation (i.e., substation termination). The two points of interconnection are reflected in Exhibit 2.

11. As shown in Exhibit 2, KATCo proposes to remove existing Structure #31 and install two (2) new single circuit switch structures, Structures #31A and #31C, along centerline within the existing right-of-way (“ROW”) of the Grand Point-Guilford 138 kV Transmission Line. The two new switch structures—Structures #31A and #31C—are single circuit steel 2000 AMP horizontal switch structures consisting of two poles on concrete-drilled pier foundations ranging in height from approximately 52-67 feet above ground, as shown in **Exhibit 3**. Proposed Structure #31A will be installed approximately 490 feet east of existing Structure #30, which will remain. Proposed Structure #31C will be installed approximately 113 feet east of existing Structure #31, which will be removed. The Project will also install one (1) vertical tap structure, Structure #31B along centerline within the existing ROW. Proposed Structure #31B will consist of a single steel pole on a concrete-drilled pier foundation approximately 97 feet in height, as shown in **Exhibit 4**. Proposed Structure #31B will be installed approximately 148 feet west of existing Structure #31, which as indicated will be removed. Finally, one (1) vertical switch structure, Structure #31B-1, will be installed within a new 100-foot-wide ROW, on property owned by Martin’s, and will consist of a single steel pole on a concrete-drilled pier foundation approximately 79 feet in height, as shown in **Exhibit 5**. Proposed Structure #31B-1 will be installed approximately 274 feet north of new Structure #31B.

12. The Project proposes to remove one structure and install a total of four new structures ranging in height from approximately 52 to 97 feet above the ground. The span lengths of the proposed transmission line extension will be approximately 275 feet from proposed Structure #31B to proposed Structure #31B-1, and approximately 150 feet from proposed Structure

#31B-1 to the End Customer-owned Cider Press Substation. The average span length on the existing transmission line is approximately 690 feet.

13. The existing Grand Point-Guilford 138 kV Transmission Line utilizes 556.5 kcmil 26/7 (“ACSR²”) shielded by two (2) ½-inch 7-Strand Extra High Strength (“EHS”) shield wires that will be transferred to the three new structures proposed within the existing ROW (Structures #31A, #31B, #31C). The proposed transmission line extension will utilize 556.5 kcmil 26/7 ACSR shielded by two (2) 7#8 Alumoweld shield wires to match the existing conductor.

14. The proposed Project will be entirely located on property owned by Martin’s, within the existing 100-foot-wide ROW³ or within new 100-foot-wide ROW secured from Martin’s. The existing easement allows for the proposed structure removals and installation of steel structures within the ROW.

15. The proposed Project involves the removal and installation of certain transmission structures entirely within an existing transmission line ROW as well as the installation of a structure and a 425-foot-long transmission line extension on the property of the sole customer to be served by the line extension. As such, the Project meets the parameters of 52 Pa. Code §§ 57.72(d)(1)(i) and (iii), which provide for filing an LON in lieu of a full siting application for a transmission line that is proposed to be located entirely within applicant’s existing transmission line ROW and proposed on property of the sole customer to be served by the line insofar as the

² “ACSR” means Aluminum Conductor Steel Reinforced.

³ The existing ROW is owned by FirstEnergy Pennsylvania Electric Company (“FE PA”), a First Energy company, in the rate district of former West Penn Power Company (“West Penn”). On December 7, 2023, the Commission approved, among other things, the merger of FirstEnergy’s Pennsylvania operating companies, including West Penn Power Company (“West Penn”), into FirstEnergy Pennsylvania Electric Company (“FE PA”). The merger transaction closed on January 1, 2024. FE PA is now the successor in interest to West Penn. For this filing, all references to property owned by FE PA, unless stated otherwise, mean property located in the rate district of former West Penn. For continuity with the merger transaction, the service territory previously served by West Penn will be referred to as the West Penn rate district for purposes of this filing.

size, character, design or configuration of the proposed Project will not substantially alter the right-of-way. Additionally, the proposed transmission line extension is less than 2 miles long and, therefore, satisfies the LON requirement under 52 Pa. Code § 57.72(d)(1)(vi).

16. The proposed transmission line extension will be designed to meet or exceed all requirements of the latest revision of the National Electrical Safety Code (“NESC”) under all operating conditions as well as FirstEnergy’s current design criteria. FirstEnergy’s design criteria state that 138 kV transmission lines shall have a designed vertical conductor-to-ground clearance of 26 feet. This design value exceeds the NESC minimum of 20.1 feet by a margin of 5.9 feet. In general, FirstEnergy’s clearance criteria exceed the NESC minimums by various margins ranging from two feet to seven feet, depending on the voltage and specific clearance measurement. The transmission line maximum operating temperature will be 212 degrees Fahrenheit.

17. The design, construction, and operation of the Project will meet or exceed all applicable safety standards established by the Occupational Safety and Health Administration (“OSHA”). Moreover, the Project will be constructed following the Companies’ standard construction practices to perform all work safely. All work will be performed in accordance with NESC, OSHA, and all other applicable state and federal requirements.

18. The proposed Project will consist of tapping the Grand Point-Guilford 138 kV Transmission Line, installing three 138 kV switches, constructing two (2) spans of 138 kV transmission line, adjusting remote end relay settings, and installing a 138 kV revenue meter (collectively the “direct connection facilities”). All three 138 kV switches will be outfitted with Supervisory Control and Data Acquisition (“SCADA”). All new network path components associated with the proposed Project will be sized such that the new equipment will not reduce the present rating of the Grand Point-Guilford 138 kV Transmission Line. The Project will be designed

in accordance with the FirstEnergy (“FE”) “Requirements for Transmission Connected Facilities” document,⁴ Figure 1B.

19. PJM Interconnection, LLC (“PJM”) is a regional transmission organization for Pennsylvania and 12 other states plus the District of Columbia. PJM functions as the regional planning coordinator, transmission planner, and transmission operator to preserve the reliability of the bulk electricity grid under its operational control. The PJM planning process culminates in a PJM Board-approved Regional Transmission Expansion Plan (“RTEP”), which identifies the need and timing of transmission system upgrades and enhancements that will provide for the operational, economic and reliability requirements of PJM customers. The RTEP consists of system upgrades produced from one or more of four planning processes: reliability planning; economic planning, interconnection planning; and local planning.

20. Supplemental upgrades are Transmission Owner-initiated projects and are part of PJM’s local planning process, which is governed by Attachment M-3 of the PJM Open Access Transmission Tariff (“OATT”). The proposed Project is a Supplemental Project or upgrade. In accordance with the Attachment M-3 process, KATCo provides information regarding the criteria used to plan and identify Supplemental Projects at a PJM Assumptions Meeting. The process for developing Supplemental Projects includes identification and review of a system “need” at a separate meeting of the PJM Subregional RTEP (“SRRTEP”) Committee, which provides an opportunity for industry stakeholders to comment of the project need. Next, there is a “solutions” meeting where potential solutions are discussed as well as any alternatives that were considered. Stakeholders may then provide comments on the potential solutions. Once PJM completes a “do no harm” analysis of the proposed solution, PJM will assign the project a Supplemental Identifier

⁴ <https://firstenergycorp.com/content/dam/feconnect/files/wholesale/Requirements-for-Transmission-Connected-Facilities.pdf>

beginning with an “s” followed by a four-digit number. Supplemental upgrades, while part of the local planning process, are not mandated or directed by PJM; however, the upgrades are necessary to address planning functions not transferred to PJM (e.g., asset management and customer interconnections).

21. In accordance with the PJM OATT, Attachment M-3, KATCo presented the End Customer’s request for electric service to PJM and its stakeholders at the PJM SRRTEP – Western “Needs” meeting on April 19, 2024. A copy of the Need presentation slide is attached as **Exhibit 6**. The solution was then presented at the subsequent SRRTEP – Western “Solutions” meeting on May 17, 2024. A copy of the Solution presentation slide is attached as **Exhibit 7**. PJM assigned the proposed Project a Supplemental Project ID number of s3481.1. KATCo and PJM Transmission Planning evaluated the proposed load addition and did not identify any KATCo or PJM Planning Criteria violations attributable to the load addition. Therefore, no transmission system upgrades are required as a result of the proposed load addition other than the required direct connection facilities necessary to provide electric service to the End Customer.

22. Stream and wetland delineations were performed by Civil & Environmental Consultants, Inc. (“CEC”) in July 2024, and the results of those field investigations are included in the Waters Delineation Report attached as **Exhibit 8**. No wetlands or streams were identified in the Project Area; therefore, the proposed Project is not expected to impact any wetlands or streams. Access to the project site will be off the existing road and within the existing ROW. No tree clearing is anticipated.

23. A Site-Specific Erosion & Sediment Plan will be completed for the Project. The Companies will implement appropriate measures during construction, and through the subsequent

operation of the Project. Best Management Practices for soil erosion measures and sedimentation control will be put in place prior to any earth disturbance.

24. A Pennsylvania Natural Diversity Inventory (“PNDI”) was conducted for the proposed Project Area. Searches conducted by the U.S. Fish and Wildlife Service, the PA Game Commission, PA Department of Conservation and Natural Resources, and the PA Fish and Boat Commission indicated no known impacts to threatened and endangered species and/or special concern species and resources associated with the proposed Project. A copy of the PNDI report, dated July 22, 2024, is included as **Exhibit 9**.

25. Consultation with the PA State Historic Preservation Office (“SHPO”) was submitted on July 25, 2024, and a clearance letter dated July 26, 2024, indicated the proposed Project would have no effect on above ground resources or archaeological resources. A copy of the SHPO clearance letter is included as **Exhibit 10**.

26. Construction is anticipated to begin on or about May 5, 2025. KATCo will construct the transmission line tap on behalf of both Companies. The Project is forecasted to be in service by June 15, 2025.

27. The estimated total cost of the proposed Project is approximately \$2,668,000. A breakdown of Project costs is as follows⁵:

Estimated Total Costs:

Engineering	\$774,000
Material	\$230,000
Construction	\$1,664,000
 Total	 \$2,668,000

⁵ KATCo will be responsible for approximately \$1,750,000 of the total project costs, for the network portion of the proposed Project, including modifications to the main line and relay work. The remaining costs will be allocated between FE PA and the End Customer with a “true up” of actual costs upon project completion. As currently estimated, the End Customer will be responsible for approximately \$881,000 without tax, which includes the costs for installing the new tap segment and integration of customer protection and controls.

28. At the time of this filing, no comments from state or local officials have been received for the Project.

29. As required by 52 Pa. Code § 57.72(d)(4), the Companies state:

The Commission will review and, by order, approve or disapprove a letter of notification. If the Commission approves a letter of notification, the HV line shall be located and constructed without the application process set forth in this subchapter. If the Commission does not approve the letter of notification, its order shall direct the applicant to comply with the application process set forth in this subchapter.

30. In accordance with the provisions of 52 Pa. Code § 57.72(d)(3), a copy of this Letter of Notification filing will be served by certified mail upon those who are entitled to receive a copy of an application or notice of filing an application as set forth in 52 Pa. Code § 57.74 and as shown in the attached Certificate of Service.

WHEREFORE, Keystone Appalachian Transmission Company and FirstEnergy Pennsylvania Electric Company respectfully request that the Commission review and approve this Letter of Notification on or before the April 10, 2025 Public Meeting so that construction can begin immediately thereafter.

Dated: February 5, 2025

By:



Joey T. Chen
Attorney ID #334709
76 South Main St.
Akron, OH 44308
(610) 921-6784
Email: jchen@firstenergycorp.com

*Counsel for Keystone Appalachian Transmission
Company and FirstEnergy Pennsylvania Electric
Company*

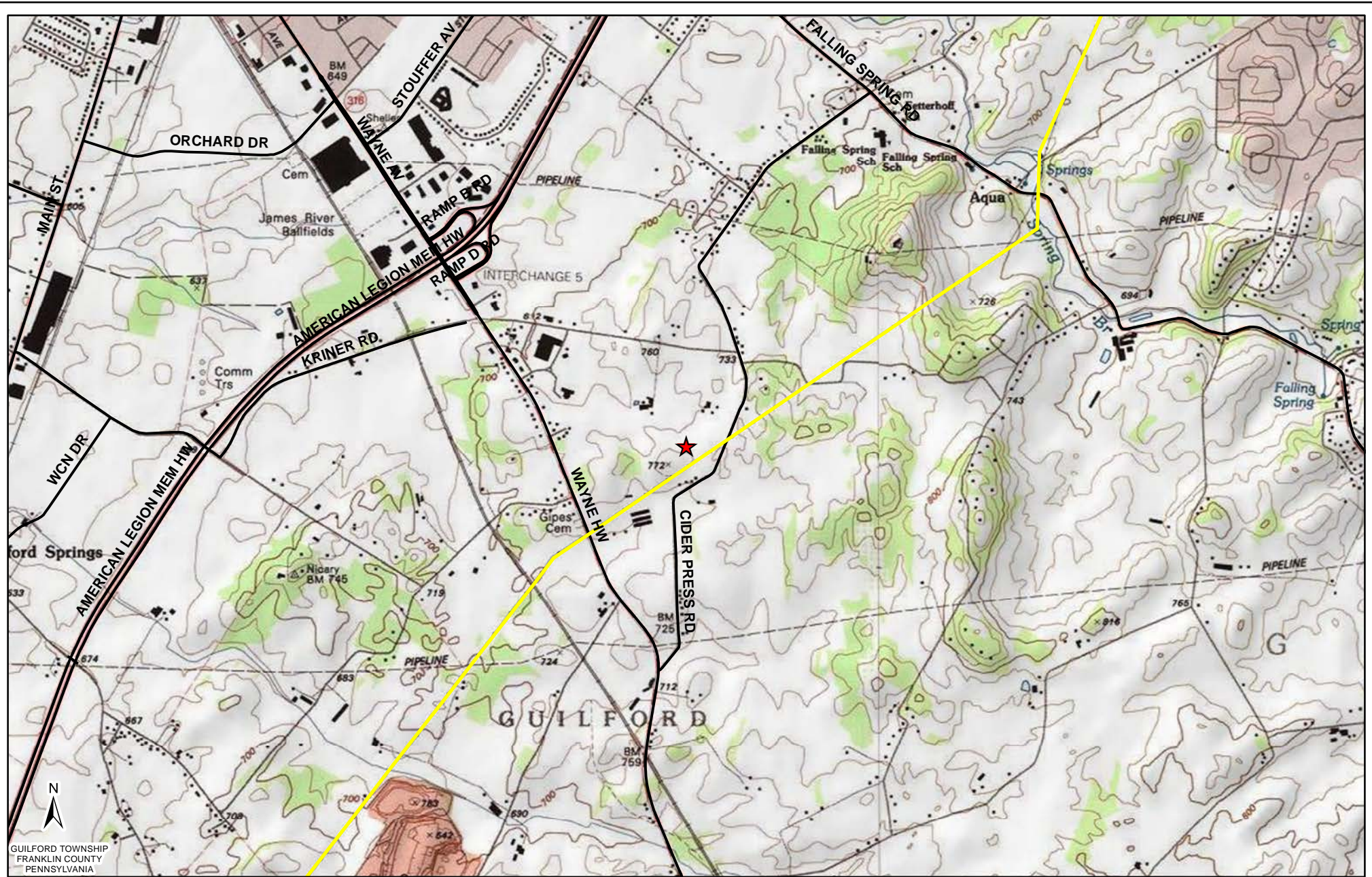

LEGEND:

- ★ Project Location
- Transmission Line
- Roads

0 1,000 2,000 4,000
Feet

Reference:
USGS Topographical Overlay; PennDOT

Coordinate System:
NAD 1983 StatePlane Pennsylvania South FIPS 3702 Feet
Projection: Lambert Conformal Conic; Units: Foot US

MARYLAND

EXHIBIT 1

Grand Point-Guilford 138 kV Transmission Line Tap to Cider Press Substation Project

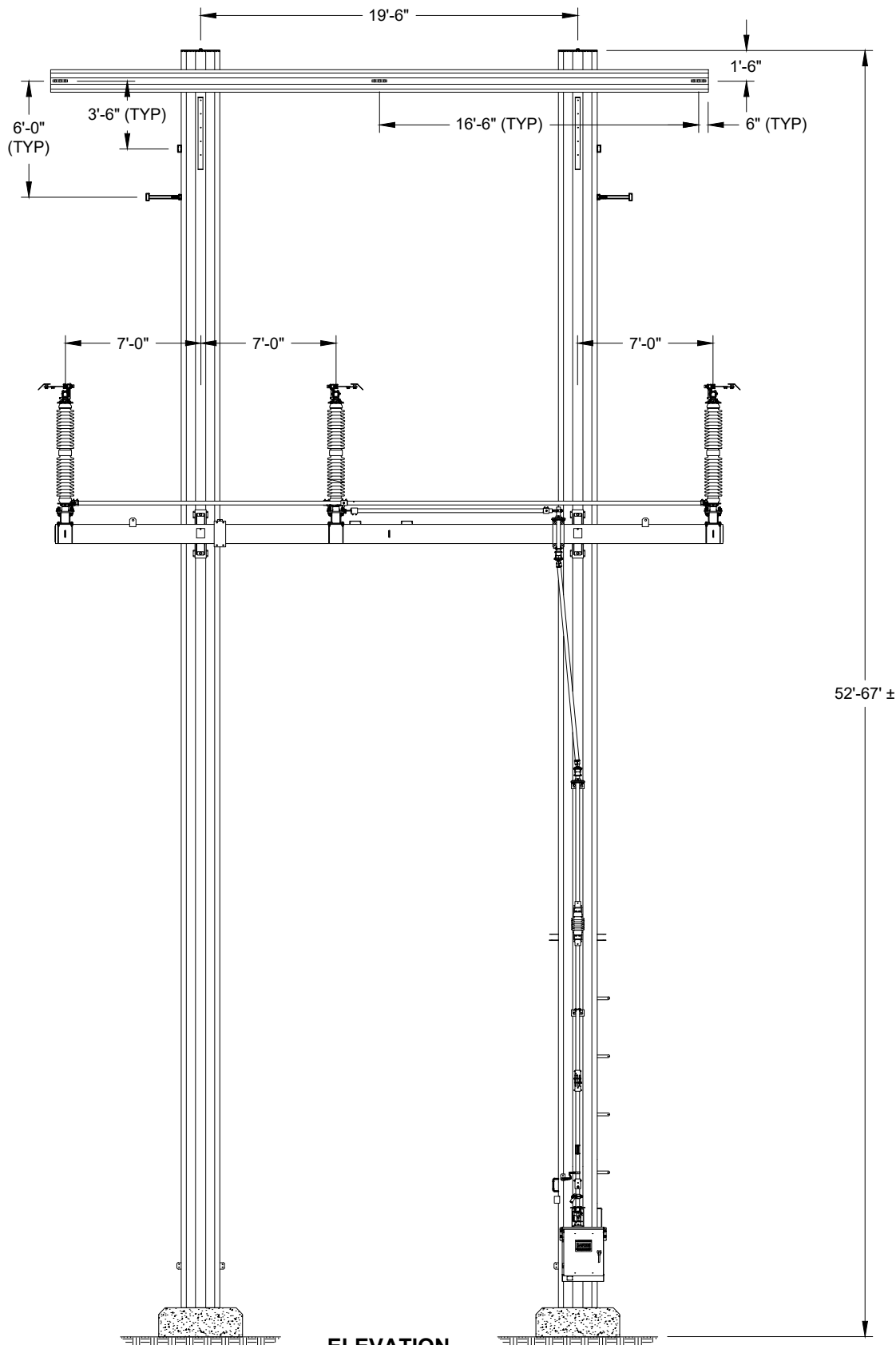

ELEVATION
LOOKING AT FACE 1



GRAND POINT-GUILFORD 138KV LINE
TAP TO CIDER PRESS SUBSTATION

138KV SINGLE CIRCUIT STEEL 2000A SWITCH
STRUCTURE HORIZONTAL DOUBLE POLE
STRUCTURE 31A & 31C

EXHIBIT 3

PAPER SIZE: 8.5X11

SCALE: NTS

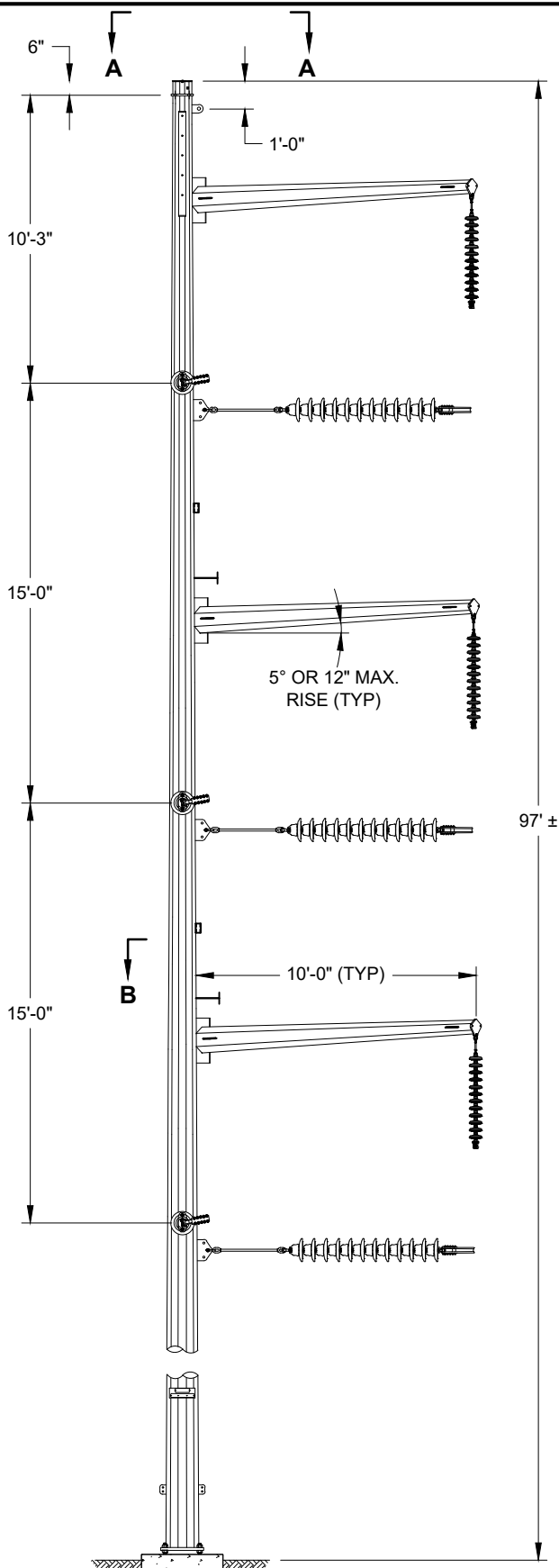

ELEVATION
LOOKING AT FACE 1

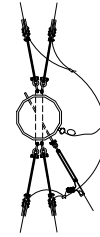

SECTION A-A
SHIELD WIRE PLAN VIEW

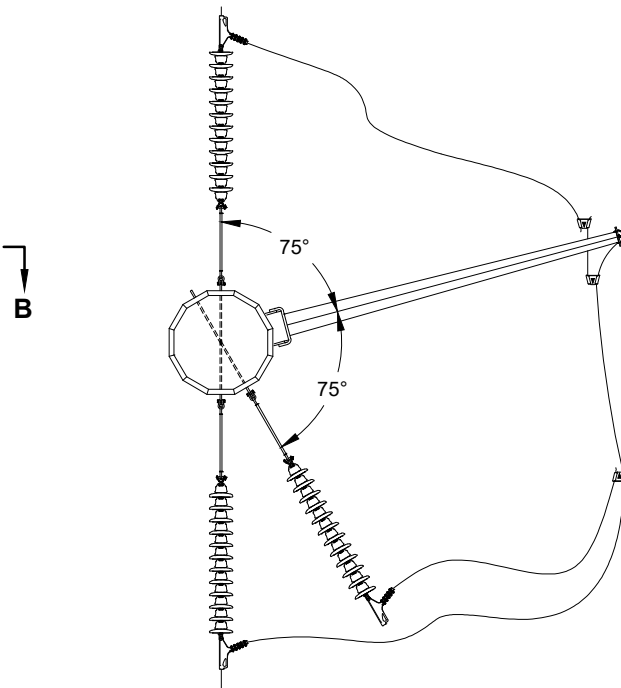

SECTION B-B
CONDUCTOR PLAN VIEW



GRAND POINT-GUILFORD 138KV LINE
TAP TO CIDER PRESS SUBSTATION

138KV SINGLE CIRCUIT STEEL TAP STRUCTURE
VERTICAL SINGLE POLE
STRUCTURE 31B

EXHIBIT 4

PAPER SIZE: 8.5X11

SCALE: NTS

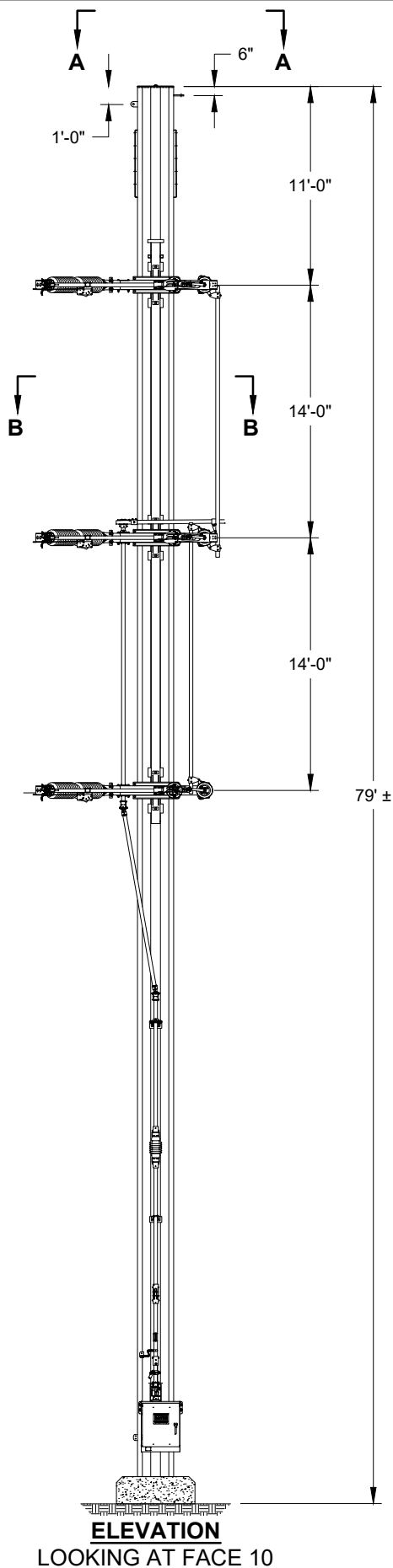

ELEVATION
LOOKING AT FACE 10

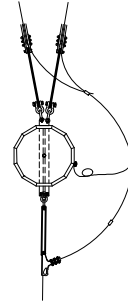

SECTION A-A
SHIELD WIRE PLAN VIEW

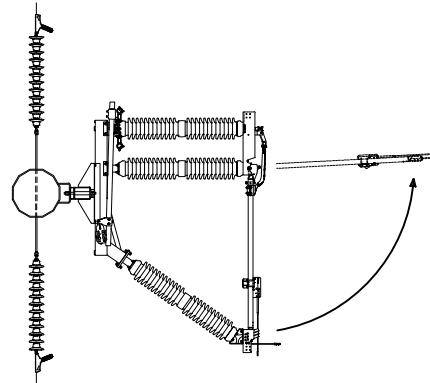

SECTION B-B
CONDUCTOR PLAN VIEW

KATCo
Keystone Appalachian Transmission Company
 A FirstEnergy Company

GRAND POINT-GUILFORD 138KV LINE
TAP TO CIDER PRESS SUBSTATION

138KV SINGLE CIRCUIT STEEL 2000A SWITCH
STRUCTURE VERTICAL SINGLE POLE
STRUCTURE 31B-1

EXHIBIT 5

PAPER SIZE: 8.5X11

SCALE: NTS



Need Number: APS-2024-035

Process Stage: Need Meeting – 04/19/2024

Project Driver(s):

Customer Service

Specific Assumption Reference:

New customer connection request will be evaluated per FirstEnergy’s “Requirements for Transmission Connected Facilities” document and “Transmission Planning Criteria” document.

Problem Statement:

New Customer Connection – A retail customer requested 138 kV service for load of approximately 9 MW near the Grand Point – Guilford 138 kV Line. The request is approximately four miles from Guilford Substation.

Requested in-service date is 8/29/2025.

APS Transmission Zone M-3 Process Grand Point – Guilford 138 kV Line Customer Connection

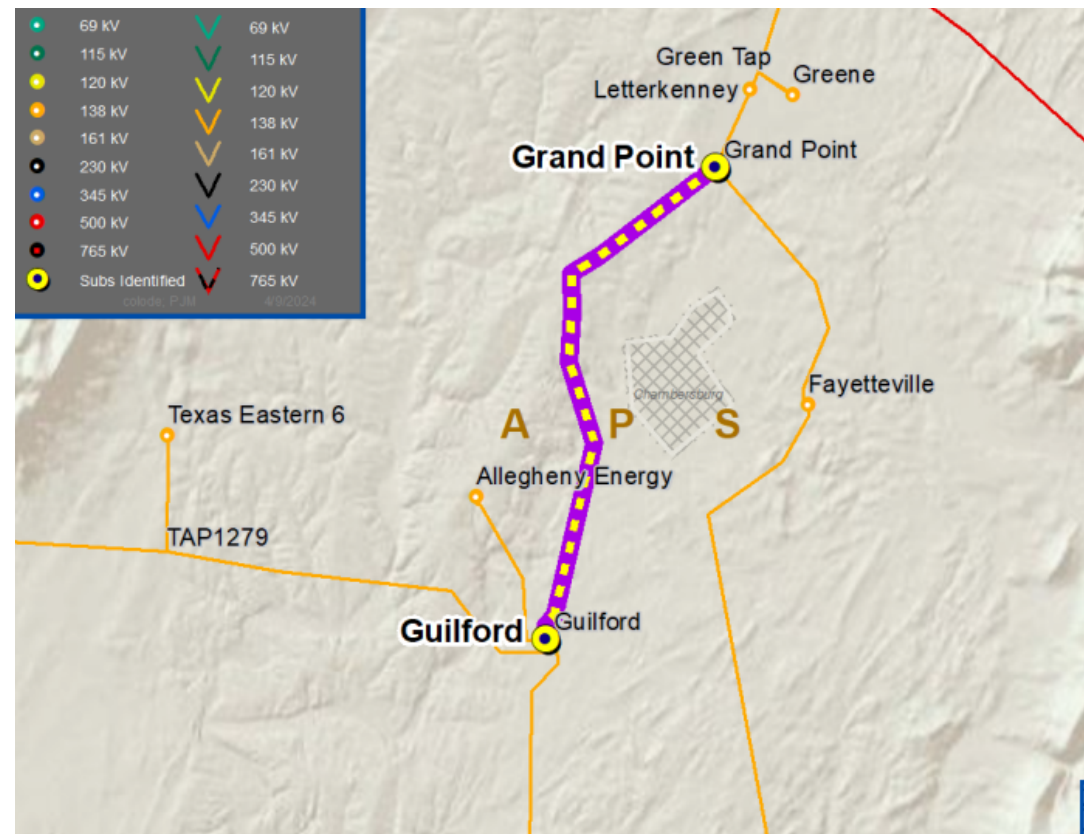



Need Number: APS-2024-035

Process Stage: Solution Meeting – 05/17/2024

Previously Presented: Need Meeting – 04/19/2024

Project Driver(s):

Customer Service

Specific Assumption Reference:

New customer connection request will be evaluated per FirstEnergy’s “Requirements for Transmission Connected Facilities” document and “Transmission Planning Criteria” document.

Problem Statement:

New Customer Connection – A retail customer requested 138 kV service for load of approximately 9 MW near the Grand Point – Guilford 138 kV Line. The request is approximately four miles from Guilford Substation.

Requested in-service date is 8/29/2025.

APS Transmission Zone M-3 Process Grand Point – Guilford 138 kV Line Customer Connection

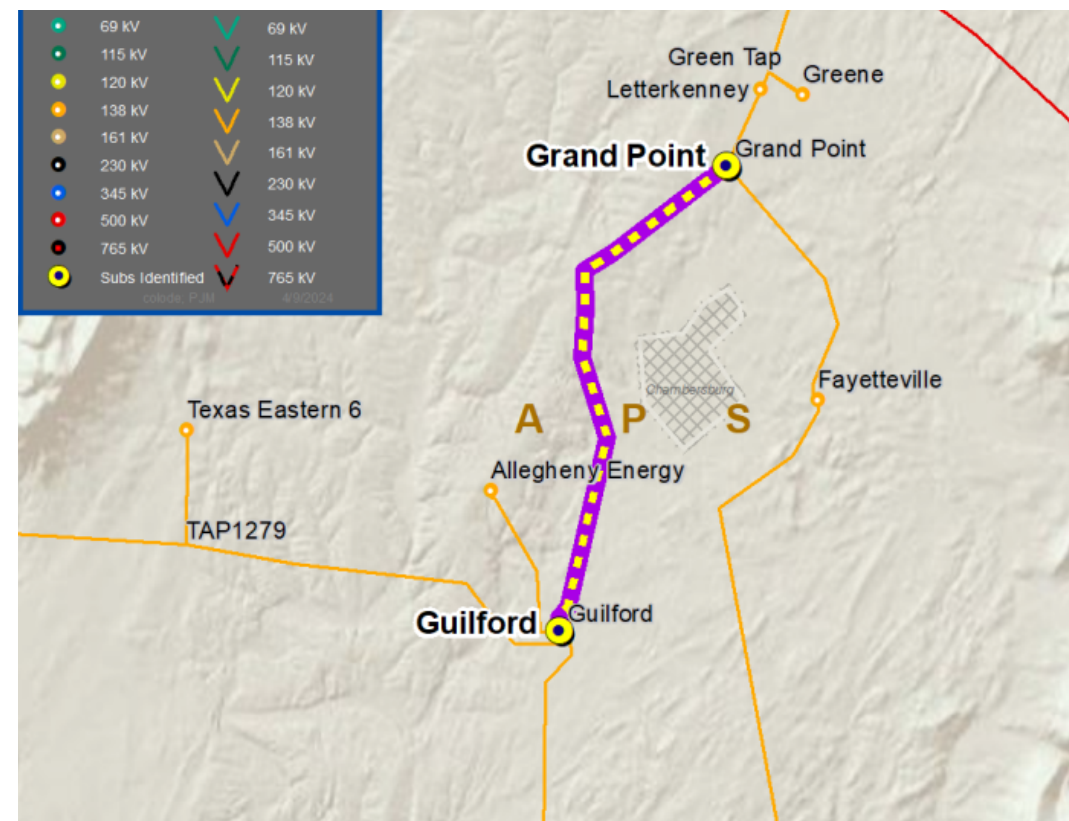



APS Transmission Zone M-3 Process Grand Point – Guilford 138 kV Line Customer Connection

Need Number: APS-2024-035

Process Stage: Solution Meeting – 05/17/2024

Proposed Solution:

138 kV Transmission Line Tap

- Tap the Grandpoint – Guilford 138 kV and install two SCADA controlled switches
- Construct 500 ft of 138 kV line extension from the tap location to the Customer’s substation
- Install one SCADA controlled switch at POI between FE and Customer
- Install 138 kV revenue metering in Customer’s substation
- Modify line relay settings in Grandpoint and Guilford substations

Alternatives Considered:

- No alternative solutions considered due to customer’s proximity to Grand Point – Guilford 138 kV Line.

Estimated Project Cost: \$1.75M

Projected In-Service: 10/31/2025

Status: Engineering

Model: 2023 RTEP model for 2028 Summer (50/50)

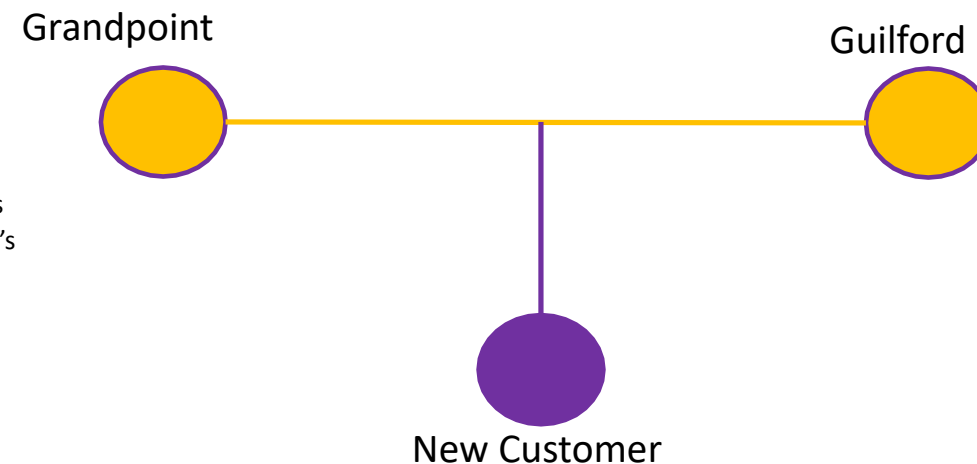

Legend	
500 kV	
345 kV	
138 kV	
69 kV	
34.5 kV	
23 kV	
New	

WATERS DELINEATION REPORT
GRAND POINT-GUILFORD 138KV CIDER PRESS INTERCONNECT
GUILFORD TOWNSHIP
FRANKLIN COUNTY, PENNSYLVANIA

Prepared For:

PENELEC,
A FIRSTENERGY COMPANY
800 CABIN HILL DRIVE,
GREENSBURG, PA 15601

Prepared By:

CIVIL & ENVIRONMENTAL CONSULTANTS, INC.
700 CHERRINGTON PARKWAY,
MOON TOWNSHIP, PA 15108

CEC Project 326-630.0046

JULY 2024

TABLE OF CONTENTS

	<u>Page</u>
1.0 Introduction.....	1
2.0 Methodology.....	2
2.1 Environmental Data Review.....	2
2.2 Field Methods.....	2
2.2.1 Wetland Delineation.....	2
2.2.2 Stream and Other Waters Delineation.....	5
3.0 Results.....	7
3.1 Environmental Data Review.....	7
3.2 Field Results.....	7
3.2.1 Wetland Delineation.....	8
3.2.2 Stream and Other Waters Delineation.....	8
4.0 Conclusions.....	9
5.0 Regulatory Considerations.....	10
6.0 Level of Care.....	12
7.0 References.....	13

TABLES

Table 1. SSURGO Soil Map Units within the Study Area

FIGURES

Figure 1. Site Location Map
Figure 2. Environmental Data Review Map
Figure 3. Waters Delineation Map

APPENDICES

Appendix A - Photographs
Appendix B - Wetland Determination Data Forms
Appendix C - Antecedent Precipitation Tool Analysis

1.0 INTRODUCTION

Civil & Environmental Consultants, Inc. (CEC) conducted a waters delineation of the Grand Point-Guilford 138KV Cider Press Interconnect project located in Guilford Township, Franklin County, Pennsylvania (39.901227, -77.634400; Figure 1). The proposed project includes building a new tap line and switch from an existing transmission line to a proposed substation.

This report includes the findings of a desktop data review and field survey. The purpose of the study was to identify, characterize, and delineate wetlands, streams, and other waters located within the area of interest (AOI). This report presents the methodology and findings.

2.0 METHODOLOGY

2.1 ENVIRONMENTAL DATA REVIEW

Prior to the field delineation, the following data sources were consulted to aid in the identification of potential wetlands, streams, and other waters within the AOI:

- U.S. Geological Survey (USGS) 7.5-minute topographic quadrangle maps;
- U.S. Department of Agriculture, Natural Resource Conservation Service (USDA-NRCS) Soil Survey Geographic (SSURGO) Database;
- Federal Emergency Management Agency (FEMA) flood hazard data;
- U.S. Fish and Wildlife Service (USFWS) National Wetlands Inventory (NWI);
- National Hydrography Dataset (NHD);
- Aerial imagery from various sources; and
- Antecedent Precipitation Tool (APT).

These publicly available data sources aided in overall habitat characterizations and facilitated potential water resource identification within the AOI; topographic depressions, mapped hydric soils, mapped NWI and NHD features, and FEMA floodplains have higher potential to contain wetlands, streams, and other surface water features.

2.2 FIELD METHODS

CEC performed a waters delineation to identify and delineate wetlands, streams, and other waters within the AOI. The following sections outline the field methods used to delineate these waters.

2.2.1 Wetland Delineation

CEC ecologists identified, characterized, and delineated wetlands in accordance with the routine, on-site determination methodology described in the U.S. Army Corps of Engineers' (USACE)

Corps of Engineers Wetlands Delineation Manual (Environmental Laboratory 1987); referred to hereafter as Corps Manual), supplemented by the following technical guidance documents:

- *Regional Supplement to the Corps of Engineers Wetland Delineation Manual: Eastern Mountains and Piedmont Region (Version 2.0)* (USACE 2012); (referred to hereafter as Regional Supplement);
- *National Wetland Plant List* (USACE 2022); and
- *Field Indicators of Hydric Soils in the United States Version 8.2* (USDA-NRCS 2018).

CEC ecologists walked the AOI and collected data at representative locations within each plant community cover type and areas with potential water features (e.g. localized depressions, converging slopes, evident hydrology, etc.). Data collected at each sampling point were recorded on USACE Wetland Determination Data Forms. The sampling plan was modified as necessary if additional plant community cover types or potential water features characteristics were encountered.

At each sampling point, the following parameters were assessed: vegetation, soils, and hydrology. First, visual estimates of percent absolute cover of plant species were recorded for each of the following strata, when present: tree, sapling/shrub, herb, and woody vine. A determination of whether the plant community was dominated by hydrophytic (wetland) plants was then made using the Rapid Test or Dominance Test indicators. Next, soils were sampled to determine if soils met hydric soil indicators. Lastly, wetland hydrology indicators (e.g., surface water, high water table, saturation, etc.) were recorded, if present.

The sampling point data were used to determine whether that point was located in a wetland or non-wetland (i.e. upland). If a wetland was identified, further sampling was performed to delineate the wetland/non-wetland boundary. Each wetland was also classified according to the NWI classification system developed by the Federal Geographic Data Committee (2013) and Cowardin et al. (1979).

- **Palustrine emergent wetland (PEM):** rooted herbaceous and grass like plants which stand erect above the water or ground surface characterize this wetland class (excluding

mosses or lichens). Vegetation is present for most of the growing season in most years. Emergent wetlands include marshes, meadows, and fens.

- **Palustrine scrub-shrub wetland (PSS):** woody vegetation less than 20 feet tall dominate this wetland class. Plant species include true shrubs, young trees, and trees or shrubs that are small or stunted because of environmental conditions. Scrub-shrub wetlands include shrub swamps and bogs.
- **Palustrine forested wetland (PFO):** woody vegetation 20 feet or taller dominate this wetland class. Forested wetlands generally include an overstory of trees, an understory of young trees and shrubs, and an herbaceous layer.
- **Palustrine unconsolidated bottom (PUB):** nontidal wetland lacking vegetation but is less than 8 hectare (20 acres) in size with a water depth in the deepest part of basin less than 2.5 meters (8.2 feet) at low water. Includes all wetlands and deepwater habitats with at least 25 percent cover of particles smaller than stones (less than 6-7 centimeter), and a vegetative cover less than 30 percent.

If more than one Cowardin classification type was identified within a wetland, the boundary between the types was delineated. Wetland boundaries were recorded using a mapping-grade handheld Global Navigational Satellite System (GNSS) receiver capable of sub-meter accuracy.

Upland habitats were also recorded on USACE Wetland Determination Data Forms. Upland sampling points were documented adjacent to wetland delineation boundaries, as well as at representative upland habitats throughout the AOI.

2.2.2 Stream and Other Waters Delineation

Concurrent with the wetland delineation, CEC ecologists walked the AOI to identify streams and other waters. These waters were evaluated for the presence of an ordinary high water mark (OHWM) in accordance with USACE Regulatory Guidance Letter (RGL) No. 05-05: Ordinary High Water Mark Identification (USACE 2005), USACE *Interim National Ordinary High Water Mark Field Delineation Manual for Rivers and Streams* (USACE 2022), and definitions under 33 CFR 328. As described in these OHWM guidance materials and 33 CFR 328.3(c)(4), an OHWM is established by a clear, natural line impressed upon the bank, shelving, changes in the character of soil, destruction of terrestrial vegetation, the presence of litter and debris, or other appropriate means that consider the characteristics of the surrounding areas. Potential jurisdiction limits are delineated using OHWM indicators as weight of evidence including geomorphic (e.g. breaks in slope), transition of vegetation types, changes in sediment type, and other indicators demarcating the regular high flow surface water elevation (e.g. observed flow event, wrack, of leaf litter disturbed or washed away). The uppermost limit of an ephemeral stream was established where the stream loses its defined bed and bank or OHWM.

In addition, all watercourses, which include streams, are defined in Pennsylvania as “a channel or conveyance of surface water having defined bed and banks” (Pennsylvania Code 2022). The federal and state guidance were applied to determine the extents of streams.

For streams, physical and biological data were used to infer the stream’s hydrologic flow regime, using a weight-of-evidence approach. CEC used field indicators such as flow, substrate composition, presence of defined bed and bank, origin of hydrologic sources, presence/absence of vegetation within the stream channel, and presence/absence benthic macroinvertebrates, fish, and other aquatic biota to classify onsite stream segments into one of three stream types:

- **Ephemeral:** surface water flows or pools only in direct response to precipitation (e.g., rain or snow fall);

- **Intermittent:** surface water flows continuously during certain times of the year and more than in direct response to precipitation (e.g., seasonally when the groundwater table is elevated or when snowpack melts); and
- **Perennial:** surface water flows continuously year-round during normal rainfall. Ground water provides the primary hydrology.

The uppermost limit of an ephemeral stream was established where the stream loses its defined bed and bank or OHWM. Stream boundaries were located using GNSS receivers capable of sub-meter accuracy. The physical characteristics of the streams and field observations were summarized on field data forms.

3.0 RESULTS

3.1 ENVIRONMENTAL DATA REVIEW

The USGS 7.5-minute topographic quadrangle and NHD stream layer identified no streams within the AOI (Figures 1 and 2). A review of the NWI data also identified no aquatic features within the study area (Figure 2). Additionally, no FEMA mapped 100-year floodplains were identified within the study area. A review of the SSURGO data identified five soil map units within the AOI (Table 1 and Figure 2). None of the soil map units have a drainage classification or hydric soil rating that would support potential wetland habitat.

Table 1. SSURGO Soil Map Units within the Study Area⁽¹⁾

Soil Map Unit Symbol	Soil Map Unit Name	Drainage Class	Hydric Rating
HaB	Hanover silt loam, 3 to 8 percent slopes	Moderately well drained	Predominantly non-hydric
HcB	Hagerstown-Carbo silty clay loams, 3 to 8 percent slopes, very rocky	Well drained	Not hydric
HcC	Hagerstown-Carbo silty clay loams, 8 to 15 percent slopes, very rocky	Well drained	Not hydric
HkD	Hagerstown-Rock outcrop complex, 8 to 35 percent slopes	Well drained	Not hydric
Fu	Funkstown silt loam	Moderately well drained	Not hydric

⁽¹⁾Web Soil Survey (<http://websoilsurvey.nrcs.usda.gov>), accessed 06/07/2024.

3.2 FIELD RESULTS

CEC staff conducted a field delineation on May 30, 2024 to identify, delineate, and classify wetlands, streams, and other waters within the AOI. The AOI consisted of agricultural fields, cattle pastures, and an existing powerline right-of-way. No aquatic features were identified within the AOI (Figure 3). Site photographs are included in Appendix A. Wetland Determination Data Forms for representative upland sample points are provided in Appendix B.

CEC ran the Antecedent Precipitation Tool (APT) to assess the climatic conditions at the time of the field delineation. The APT compares antecedent or recent rainfall conditions for this location versus the range of normal rainfall conditions that occurred during the preceding 30 years. The APT tool evaluates normal precipitation conditions, assesses the presence of drought conditions, and the approximate dates of wet and dry seasons for a given location. The APT analysis indicated normal conditions were present at the time of the field delineation. Additionally, the Palmer Drought Severity Index (PDSI) described “Incipient wetness” at the time of the analysis. The results of the APT analysis are included in Appendix C.

3.2.1 Wetland Delineation

No wetlands were identified within the AOI. Four (4) sampling points were taken to document upland habitats within the AOI. These upland habitats included planted farm fields and open meadows.

3.2.2 Stream and Other Waters Delineation

No streams or other water bodies were identified within the AOI.

4.0 CONCLUSIONS

CEC conducted a waters delineation within the AOI on May 30, 2024. CEC identified no wetlands, streams, or other aquatic resources within the study area.

5.0 REGULATORY CONSIDERATIONS

The USACE has authority to permit the discharge of dredged or fill material into WOTUS under Section 404 of the federal Clean Water Act, and to permit work and the placement of structures in navigable waters under Sections 9 and 10 of the Rivers and Harbors Act of 1899. Wetlands, streams, and other waters that meet the guidelines contained in the Corps Manual, Regional Supplement, and Regulatory Guidance Letter No. 05-05 are subject to regulation by USACE as WOTUS as defined by 33 CFR 328.3(a), and the currently in effect regulatory definition (SCOTUS 2023).

As a result of ongoing litigation with the January 2023 Revised Definition of ‘Waters of the United States’ Rule (2023 WOTUS Rule), federal agencies will implement the 2023 WOTUS Rule, as amended by the conforming rule, in 23 states, the District of Columbia, and the U.S. Territories. In the other 27 states and for certain parties, the agencies are interpreting "WOTUS" consistent with the pre-2015 regulatory regime and the Supreme Court's decision in *Sackett v. Environmental Protection Agency* (May 24, 2023) until further notice.

If CWA Section 404 authorization and/or other federal permits are required for the proposed project, consultation with the USFWS will likely be required pursuant to Section 7 of the Endangered Species Act. Furthermore, consultation with the State Historic Preservation Office may also be required relative to potential effects to resources listed on or eligible for listing on the National Register of Historic Places.

The PADEP has coinciding jurisdiction over “waters of the Commonwealth” as established by the Dam Safety and Encroachments Act (P.L. 1375, No. 325) and the Clean Streams Law (P.L. 1987, No. 3941). The PA Code of State Regulations, in Title 25, Chapter 105 Dam Safety and Waterway Management, defines “waters of the Commonwealth” as any watercourse, stream, waterbody, or wetland, including their floodways. Like the USACE, the PADEP generally considers channels to be potentially jurisdictional if they exhibit defined bed and banks, whether natural or artificial, with perennial or intermittent flow. The PADEP regulates encroachments, defined as “any structure or activity which changes, expands or diminishes the course, current or cross section of

a watercourse, floodway, or body of water” through the Chapter 105 permit process. The floodway is defined as extending 50 feet from the top of bank of watercourses if not delineated by a Federal Emergency Management Agency (FEMA) study.

In Pennsylvania, the USACE has delegated authority to the PADEP to authorize minor qualifying activities through the state-wide Section 404 permit titled PA State Programmatic General Permit 6 (PASPGP-6), with concurrent review by USACE for certain categories of impacts. A Joint Permit Application to PADEP and USACE is typically required for activities with more significant impacts that exceed the thresholds of PA Chapter 105 General Permits and PASPGP-6. In addition to encroachments, permits for discharges to waters, including from construction stormwater runoff or erosion, may be required by National Pollutant Discharge Elimination System (NPDES) and PA Chapter 102 regulations.

Waters within the AOI were delineated using guidelines set forth by the Pennsylvania DEP and USACE, which have final regulatory authority on the jurisdiction and extents of wetlands, streams, and other waters.

It is the responsibility of any party that intends to discharge dredge or fill material into regulated waters to comply with all applicable regulations.

6.0 LEVEL OF CARE

This waters delineation has been prepared based on the best available information, interpreted in the light of the investigator's training, experience, and professional judgement in conformance with USACE and other applicable agency guidelines, and with the level of care and skill ordinarily exercised by members of the environmental consulting profession practicing contemporaneously under similar conditions in the locality of the site. The waters boundaries described in this report may change subsequent to CEC's delineation based on changes in the regulatory criteria, seasonal variations in hydrology, alterations to drainage patterns, and other human activities and/or land disturbances.

Report Prepared By:

07/30/2024

Justin Peel
Staff Scientist
Civil & Environmental Consultants, Inc.

Date

Report Reviewed By:

07/30/2024

Evan McClung
Sr. Project Manager
Civil & Environmental Consultants, Inc.

Date

7.0 REFERENCES

- Cowardin, L. M., V. Carter, F. C. Golet, and E. T. LaRoe. 1979. *Classification of Wetlands and Deepwater Habitats of the United States*. Publication No. FWS/OBS-79/31, Washington, D.C.: U.S. Department of the Interior, Fish and Wildlife Service.
- Environmental Laboratory. 1987. *Corps of Engineers Wetlands Delineation Manual*. Technical Report Y-87-1, Vicksburg, Mississippi: Department of the Army, U.S. Army Engineer Waterways Experiment Station.
- Federal Geographic Data Committee. 2013. *Classification of Wetlands and Deepwater Habitats of the United States*. FGDC-STD-004-2013. Second Edition. Wetlands Subcommittee, Federal Geographic Data Committee and U.S. Fish and Wildlife Service, Washington, DC.
- U.S. Congress. 1977. *Clean Water Act*. Codified at 33 U.S.C. 1251 (et seq.), Washington, DC: U.S. Government Printing Office.
- U.S. Congress. 1986. *Definition of "Waters of the United States"*. Codified at 33 CFR 328.3 (et seq.), Washington, DC: U.S. Government Printing Office.
- U.S. Congress. 1899. *Rivers and Harbors Appropriation Act of 1899*. Codified at 33 U.S.C. 403 (et seq.), Washington, DC: U.S. Government Printing Office.
- USACE. 2022. *National Ordinary High Water Mark Field Delineation Manual for Rivers and Streams, Interim Version*. Report #ERDC/CRREL TR-22-16. Available from <http://dx.doi.org/10.21079/11681/46102>.
- . 2022. National Wetland Plant List, version 3.6. <https://wetland-plants.sec.usace.army.mil/>
- . 2005. "Ordinary High Water Mark Identification." *Regulatory Guidance Letter No. 05-05*. Washington, DC: U.S. Army Corps of Engineers.
- . 2012. *Regional Supplement to the Corps of Engineers Wetland Delineation Manual: Eastern Mountains and Piedmont Region Version 2.0*. Edited by J. F. Berkowitz, J. S. Wakeley, R. W. Lichvar and C. V. Noble. Vicksburg, Mississippi: U.S. Army Engineer Research and Development Center.
- USDA-NRCS. 2018. *Field Indicators of Hydric Soils in the United States, Version 8.2*. Edited by L. M. Vasilas, G. W. Hurt and J. F. Berkowitz. Washington, D.C.: USDA-NRCS, in cooperation with the National Technical Committee for Hydric Soils.

Soil Survey Staff, Natural Resources Conservation Service, United States Department of Agriculture. Web Soil Survey. Available online at <https://websoilsurvey.nrcs.usda.gov/>.

FIGURES



SUBMITTAL & REVISION RECORD

NO	DATE	DESCRIPTION
--	--	--

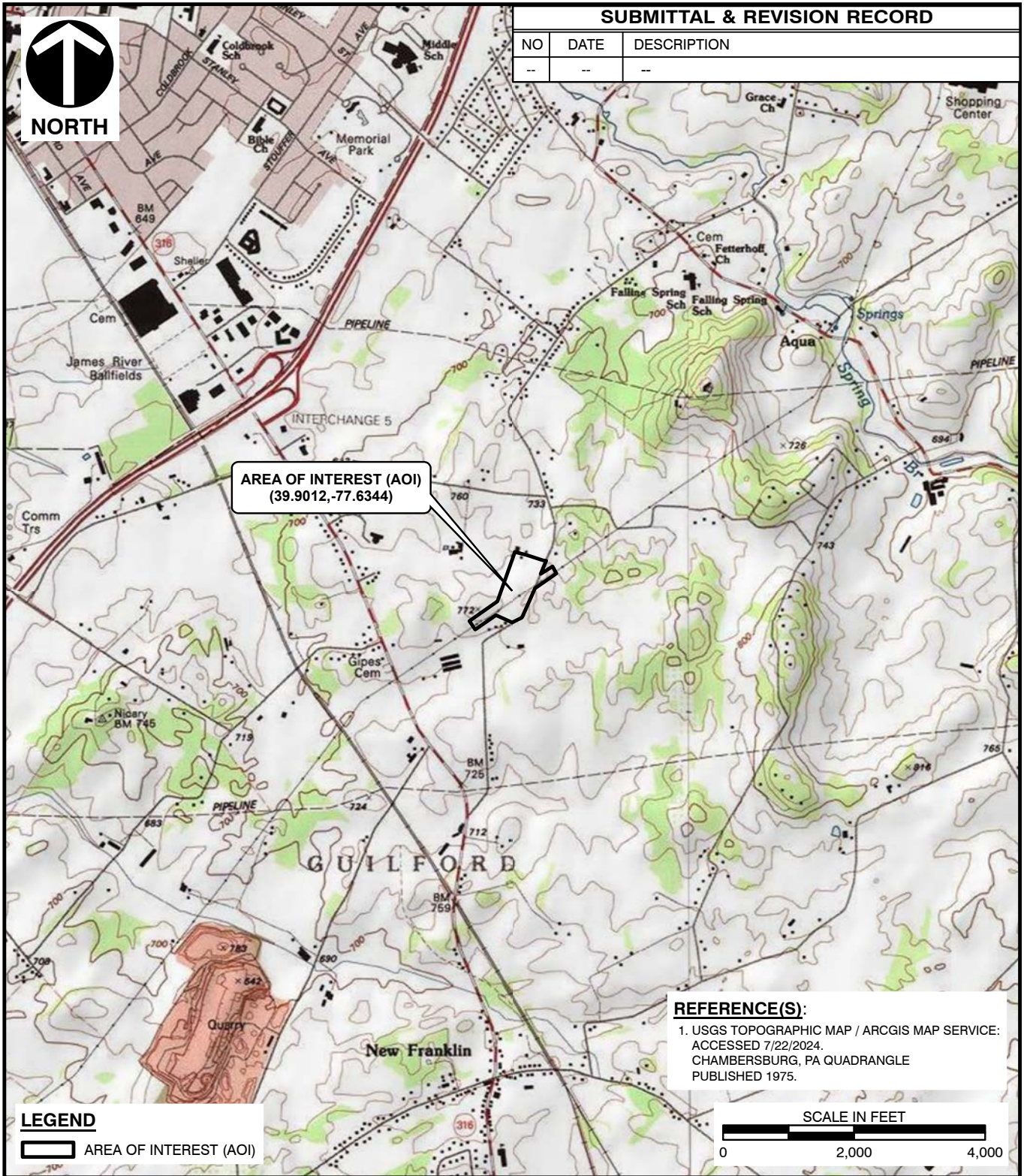

AREA OF INTEREST (AOI)
(39.9012, -77.6344)

REFERENCE(S):

1. USGS TOPOGRAPHIC MAP / ARCGIS MAP SERVICE:
ACCESSSED 7/22/2024.
CHAMBERSBURG, PA QUADRANGLE
PUBLISHED 1975.

LEGEND

AREA OF INTEREST (AOI)

SCALE IN FEET



P:\920-000\926-630\GIS\Maps\EC57_GP_Guilford_Delineation\326630_EC57_GP_Guilford_Delineation.aprx 7/22/2024 11:01 AM (ccpyrch)



Civil & Environmental
Consultants, Inc.

700 Cherrington Parkway
Moon Township, PA 15108
Ph: 412.429.2324 · 800.365.2324
www.cecinc.com

**PENELEC A FIRST ENERGY COMPANY
GRAND POINT - GUILFORD 138KV LINE
FRANKLIN COUNTY, PENNSYLVANIA**

SITE LOCATION MAP

DRAWN BY: CLC	CHECKED BY: JDP	APPROVED BY: MRM*	FIGURE NO: 1
DATE: 7/22/2024	SCALE: 1" = 2,000'	PROJECT NO: 326-630	

*Hand Signature on file

SUBMITTAL & REVISION RECORD		
NO	DATE	DESCRIPTION
--	--	--

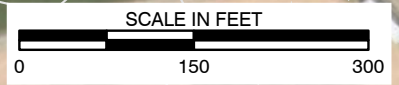
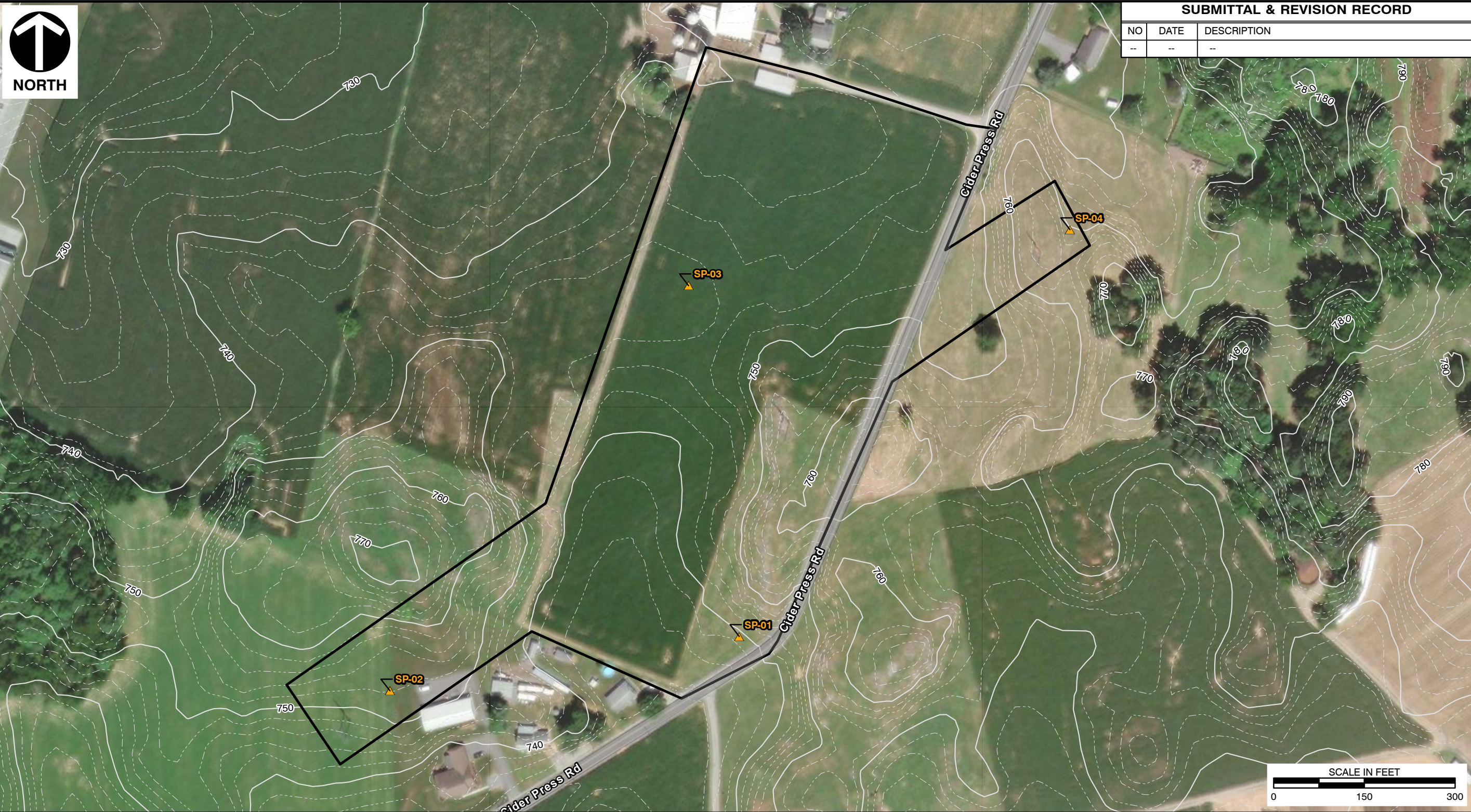

P:\920-000\926-630\GIS\Maps\EC57_GP_Guilford_Delineation.aprx 7/22/2024 11:01 AM (ccpyrch)

LEGEND

	AREA OF INTEREST (AOI)
	SAMPLING POINT
	INDEX CONTOUR
	INTERMEDIATE CONTOUR

REFERENCES
 1. PENNSYLVANIA EMERGENCY MANAGEMENT AGENCY (PEMA) IMAGERY WEB MAPPING SERVICE
 IMAGE DATE: 2018-2020; ACCESSED: 6/10/2024.



Civil & Environmental Consultants, Inc.
 700 Cherrington Parkway
 Moon Township, PA 15108
 Ph: 412.429.2324 · 800.365.2324
 www.cecinc.com

**PENELEC A FIRST ENERGY COMPANY
 GRAND POINT - GUILFORD 138KV LINE
 FRANKLIN COUNTY, PENNSYLVANIA**

WATERS DELINEATION MAP

DRAWN BY: CLC	CHECKED BY: JDP	APPROVED BY: MRM*	FIGURE NO: 3
DATE: 7/22/2024	SCALE: 1" = 150'	PROJECT NO: 326-630	

*Hand Signature on file

APPENDIX A

PHOTOGRAPHIC SUMMARY



1. Sample Point SP-001, Upland Facing Northwest



2. Sample Point SP-002, Upland Facing Northeast



3. Sample Point SP-003, Upland Facing West



4. Sample Point SP-004, Upland Facing Southwest



5. Site Overview Facing Southwest



6. Site Overview Facing East



Civil & Environmental Consultants, Inc.

Pittsburgh, PA 15205
Phone: (800) 365-2324
www.cecinc.com

PENELEC, A FirstEnergy Company
Grand Point-Guilford 138kV Cider Press Interconnect
326-630.0046

Photographs Taken: May 30, 2024



7. Site Overview
Facing East



8. Site Overview
Facing West



9. Site Overview
Facing North



10. Site Overview
Facing West



11. Site Overview
Facing North



12. Site Overview
Facing East



Civil & Environmental Consultants, Inc.

Pittsburgh, PA 15205
Phone: (800) 365-2324
www.cecinc.com

PENELEC, A FirstEnergy Company
Grand Point-Guilford 138kV Cider Press Interconnect
326-630.0046

Photographs Taken: May 30, 2024

APPENDIX B

WETLAND DETERMINATION DATA FORMS

U.S. Army Corps of Engineers WETLAND DETERMINATION DATA SHEET – Eastern Mountains and Piedmont Region See ERDC/EL TR-12-9; the proponent agency is CECW-CO-R	OMB Control #: 0710-0024, Exp:11/30/2024 Requirement Control Symbol EXEMPT: (Authority: AR 335-15, paragraph 5-2a)
--	--

Project/Site: Grand Point-Guilford 138kV Line City/County: Franklin Sampling Date: 5/30/24
 Applicant/Owner: FirstEnergy Service Company State: PA Sampling Point: SP-001
 Investigator(s): AFG, JMP Section, Township, Range: Guilford
 Landform (hillside, terrace, etc.): Hillslope Local relief (concave, convex, none): Convex Slope (%): 3-5
 Subregion (LRR or MLRA): LRR N Lat: 39.900172 Long: -77.634292 Datum: NAD 83
 Soil Map Unit Name: Funkstown silt loam; Fu NWI classification: None

Are climatic / hydrologic conditions on the site typical for this time of year? Yes X No (If no, explain in Remarks.)
 Are Vegetation No, Soil No, or Hydrology No significantly disturbed? Are "Normal Circumstances" present? Yes X No
 Are Vegetation No, Soil No, or Hydrology No naturally problematic? (If needed, explain any answers in Remarks.)

SUMMARY OF FINDINGS – Attach site map showing sampling point locations, transects, important features, etc.

Hydrophytic Vegetation Present? Yes <u> </u> No <u>X</u> Hydric Soil Present? Yes <u> </u> No <u>X</u> Wetland Hydrology Present? Yes <u> </u> No <u>X</u>	Is the Sampled Area within a Wetland? Yes <u> </u> No <u>X</u>
Remarks: Upland sample point was located on a hillslope in a cow pasture that was recently mowed and had multiple embedded rock areas throughout the pasture.	

HYDROLOGY

Wetland Hydrology Indicators: Primary Indicators (minimum of one is required; check all that apply)	Secondary Indicators (minimum of two required)
<input type="checkbox"/> Surface Water (A1) <input type="checkbox"/> True Aquatic Plants (B14) <input type="checkbox"/> High Water Table (A2) <input type="checkbox"/> Hydrogen Sulfide Odor (C1) <input type="checkbox"/> Saturation (A3) <input type="checkbox"/> Oxidized Rhizospheres on Living Roots (C3) <input type="checkbox"/> Water Marks (B1) <input type="checkbox"/> Presence of Reduced Iron (C4) <input type="checkbox"/> Sediment Deposits (B2) <input type="checkbox"/> Recent Iron Reduction in Tilled Soils (C6) <input type="checkbox"/> Drift Deposits (B3) <input type="checkbox"/> Thin Muck Surface (C7) <input type="checkbox"/> Algal Mat or Crust (B4) <input type="checkbox"/> Other (Explain in Remarks) <input type="checkbox"/> Iron Deposits (B5) <input type="checkbox"/> Inundation Visible on Aerial Imagery (B7) <input type="checkbox"/> Water-Stained Leaves (B9) <input type="checkbox"/> Aquatic Fauna (B13)	<input type="checkbox"/> Surface Soil Cracks (B6) <input type="checkbox"/> Sparsely Vegetated Concave Surface (B8) <input type="checkbox"/> Drainage Patterns (B10) <input type="checkbox"/> Moss Trim Lines (B16) <input type="checkbox"/> Dry-Season Water Table (C2) <input type="checkbox"/> Crayfish Burrows (C8) <input type="checkbox"/> Saturation Visible on Aerial Imagery (C9) <input type="checkbox"/> Stunted or Stressed Plants (D1) <input type="checkbox"/> Geomorphic Position (D2) <input type="checkbox"/> Shallow Aquitard (D3) <input type="checkbox"/> Microtopographic Relief (D4) <input type="checkbox"/> FAC-Neutral Test (D5)

Field Observations: Surface Water Present? Yes <u> </u> No <u>X</u> Depth (inches): <u> </u> Water Table Present? Yes <u> </u> No <u>X</u> Depth (inches): <u> </u> Saturation Present? Yes <u> </u> No <u>X</u> Depth (inches): <u> </u> (includes capillary fringe)	Wetland Hydrology Present? Yes <u> </u> No <u>X</u>
--	---

Describe Recorded Data (stream gauge, monitoring well, aerial photos, previous inspections), if available:

Remarks:

VEGETATION (Four Strata) – Use scientific names of plants.

Sampling Point: SP-001

Tree Stratum (Plot size: <u>30'R</u>)	Absolute % Cover	Dominant Species?	Indicator Status
1. None			
2.			
3.			
4.			
5.			
6.			
7.			

Dominance Test worksheet:

Number of Dominant Species That Are OBL, FACW, or FAC: 1 (A)
 Total Number of Dominant Species Across All Strata: 2 (B)
 Percent of Dominant Species That Are OBL, FACW, or FAC: 50.0% (A/B)

=Total Cover

50% of total cover: _____ 20% of total cover: _____

Prevalence Index worksheet:

Total % Cover of:	Multiply by:
OBL species _____	x 1 = _____
FACW species _____	x 2 = _____
FAC species _____	x 3 = _____
FACU species _____	x 4 = _____
UPL species _____	x 5 = _____
Column Totals: _____ (A)	_____ (B)
Prevalence Index = B/A = _____	

Sapling/Shrub Stratum (Plot size: <u>15'R</u>)	Absolute % Cover	Dominant Species?	Indicator Status
1. None			
2.			
3.			
4.			
5.			
6.			
7.			
8.			
9.			

Hydrophytic Vegetation Indicators:

- 1 - Rapid Test for Hydrophytic Vegetation
- 2 - Dominance Test is >50%
- 3 - Prevalence Index is ≤3.0¹
- 4 - Morphological Adaptations¹ (Provide supporting data in Remarks or on a separate sheet)
- Problematic Hydrophytic Vegetation¹ (Explain)

=Total Cover

50% of total cover: _____ 20% of total cover: _____

¹Indicators of hydric soil and wetland hydrology must be present, unless disturbed or problematic.

Herb Stratum (Plot size: <u>5'R</u>)	Absolute % Cover	Dominant Species?	Indicator Status
1. <i>Phalaris arundinacea</i>	40	Yes	FACW
2. <i>Dactylis glomerata</i>	25	Yes	FACU
3. <i>Juncus effusus</i>	15	No	FACW
4. <i>Lolium perenne</i>	15	No	FACU
5.			
6.			
7.			
8.			
9.			
10.			
11.			

Definitions of Four Vegetation Strata:

Tree – Woody plants, excluding vines, 3 in. (7.6 cm) or more in diameter at breast height (DBH), regardless of height.

Sapling/Shrub – Woody plants, excluding vines, less than 3 in. DBH and greater than or equal to 3.28 ft (1 m) tall.

Herb – All herbaceous (non-woody) plants, regardless of size, and woody plants less than 3.28 ft tall.

Woody Vine – All woody vines greater than 3.28 ft in height.

95 =Total Cover

50% of total cover: 48 20% of total cover: 19

Woody Vine Stratum (Plot size: <u>30'R</u>)	Absolute % Cover	Dominant Species?	Indicator Status
1. None			
2.			
3.			
4.			
5.			

Hydrophytic Vegetation Present?

Yes _____ No X

Remarks: (Include photo numbers here or on a separate sheet.)

SOIL

Sampling Point: SP-001

Profile Description: (Describe to the depth needed to document the indicator or confirm the absence of indicators.)

Depth (inches)	Matrix		Redox Features				Texture	Remarks
	Color (moist)	%	Color (moist)	%	Type ¹	Loc ²		
0-4	10YR 4/3	100					Loamy/Clayey	silty clay loam
4-16	7.5YR 5/6	100					Loamy/Clayey	

¹Type: C=Concentration, D=Depletion, RM=Reduced Matrix, MS=Masked Sand Grains.

²Location: PL=Pore Lining, M=Matrix.

Hydric Soil Indicators:

- Histosol (A1)
- Histic Epipedon (A2)
- Black Histic (A3)
- Hydrogen Sulfide (A4)
- Stratified Layers (A5)
- 2 cm Muck (A10) (**LRR N**)
- Depleted Below Dark Surface (A11)
- Thick Dark Surface (A12)
- Sandy Mucky Mineral (S1)
- Sandy Gleyed Matrix (S4)
- Sandy Redox (S5)
- Stripped Matrix (S6)
- Dark Surface (S7)

- Polyvalue Below Surface (S8) (**MLRA 147, 148**)
- Thin Dark Surface (S9) (**MLRA 147, 148**)
- Loamy Mucky Mineral (F1) (**MLRA 136**)
- Loamy Gleyed Matrix (F2)
- Depleted Matrix (F3)
- Redox Dark Surface (F6)
- Depleted Dark Surface (F7)
- Redox Depressions (F8)
- Iron-Manganese Masses (F12) (**LRR N, MLRA 136**)
- Umbric Surface (F13) (**MLRA 122, 136**)
- Piedmont Floodplain Soils (F19) (**MLRA 148**)
- Red Parent Material (F21) (**MLRA 127, 147, 148**)

Indicators for Problematic Hydric Soils³:

- 2 cm Muck (A10) (**MLRA 147**)
- Coast Prairie Redox (A16) (**MLRA 147, 148**)
- Piedmont Floodplain Soils (F19) (**MLRA 136, 147**)
- Red Parent Material (F21) (**outside MLRA 127, 147, 148**)
- Very Shallow Dark Surface (F22)
- Other (Explain in Remarks)

³Indicators of hydrophytic vegetation and wetland hydrology must be present, unless disturbed or problematic.

Restrictive Layer (if observed):

Type: _____
Depth (inches): _____

Hydric Soil Present? Yes _____ No X

Remarks:

U.S. Army Corps of Engineers WETLAND DETERMINATION DATA SHEET – Eastern Mountains and Piedmont Region See ERDC/EL TR-12-9; the proponent agency is CECW-CO-R	OMB Control #: 0710-0024, Exp:11/30/2024 Requirement Control Symbol EXEMPT: (Authority: AR 335-15, paragraph 5-2a)
--	--

Project/Site: Grand Point-Guilford 138kV Line City/County: Franklin Sampling Date: 5/30/24
 Applicant/Owner: FirstEnergy Service Company State: PA Sampling Point: SP-002
 Investigator(s): AFG, JMP Section, Township, Range: Guilford
 Landform (hillside, terrace, etc.): Plain Local relief (concave, convex, none): None Slope (%): 0-1
 Subregion (LRR or MLRA): LRR N Lat: 39.899927 Long: -77.636350 Datum: NAD 83
 Soil Map Unit Name: Hagerstown-Carbo silty clay loams, 8 to 15 percent slopes, very rocky; HcC NWI classification: None
 Are climatic / hydrologic conditions on the site typical for this time of year? Yes X No (If no, explain in Remarks.)
 Are Vegetation No, Soil No, or Hydrology No significantly disturbed? Are "Normal Circumstances" present? Yes X No
 Are Vegetation No, Soil No, or Hydrology No naturally problematic? (If needed, explain any answers in Remarks.)

SUMMARY OF FINDINGS – Attach site map showing sampling point locations, transects, important features, etc.

Hydrophytic Vegetation Present? Yes <u> </u> No <u>X</u> Hydric Soil Present? Yes <u> </u> No <u>X</u> Wetland Hydrology Present? Yes <u> </u> No <u>X</u>	Is the Sampled Area within a Wetland? Yes <u> </u> No <u>X</u>
Remarks: Upland sample point is located adjacent to agricultural corn crop and maintained residential lawn in ROW.	

HYDROLOGY

Wetland Hydrology Indicators: Primary Indicators (minimum of one is required; check all that apply)	Secondary Indicators (minimum of two required)
<input type="checkbox"/> Surface Water (A1) <input type="checkbox"/> True Aquatic Plants (B14) <input type="checkbox"/> High Water Table (A2) <input type="checkbox"/> Hydrogen Sulfide Odor (C1) <input type="checkbox"/> Saturation (A3) <input type="checkbox"/> Oxidized Rhizospheres on Living Roots (C3) <input type="checkbox"/> Water Marks (B1) <input type="checkbox"/> Presence of Reduced Iron (C4) <input type="checkbox"/> Sediment Deposits (B2) <input type="checkbox"/> Recent Iron Reduction in Tilled Soils (C6) <input type="checkbox"/> Drift Deposits (B3) <input type="checkbox"/> Thin Muck Surface (C7) <input type="checkbox"/> Algal Mat or Crust (B4) <input type="checkbox"/> Other (Explain in Remarks) <input type="checkbox"/> Iron Deposits (B5) <input type="checkbox"/> Inundation Visible on Aerial Imagery (B7) <input type="checkbox"/> Water-Stained Leaves (B9) <input type="checkbox"/> Aquatic Fauna (B13)	<input type="checkbox"/> Surface Soil Cracks (B6) <input type="checkbox"/> Sparsely Vegetated Concave Surface (B8) <input type="checkbox"/> Drainage Patterns (B10) <input type="checkbox"/> Moss Trim Lines (B16) <input type="checkbox"/> Dry-Season Water Table (C2) <input type="checkbox"/> Crayfish Burrows (C8) <input type="checkbox"/> Saturation Visible on Aerial Imagery (C9) <input type="checkbox"/> Stunted or Stressed Plants (D1) <input type="checkbox"/> Geomorphic Position (D2) <input type="checkbox"/> Shallow Aquitard (D3) <input type="checkbox"/> Microtopographic Relief (D4) <input type="checkbox"/> FAC-Neutral Test (D5)
Field Observations: Surface Water Present? Yes <u> </u> No <u>X</u> Depth (inches): <u> </u> Water Table Present? Yes <u> </u> No <u>X</u> Depth (inches): <u> </u> Saturation Present? Yes <u> </u> No <u>X</u> Depth (inches): <u> </u> (includes capillary fringe)	Wetland Hydrology Present? Yes <u> </u> No <u>X</u>
Describe Recorded Data (stream gauge, monitoring well, aerial photos, previous inspections), if available:	
Remarks:	

VEGETATION (Four Strata) – Use scientific names of plants.

Sampling Point: SP-002

Tree Stratum (Plot size: <u>30'R</u>)	Absolute % Cover	Dominant Species?	Indicator Status
1. None			
2.			
3.			
4.			
5.			
6.			
7.			

Dominance Test worksheet:

Number of Dominant Species That Are OBL, FACW, or FAC: 0 (A)
 Total Number of Dominant Species Across All Strata: 3 (B)
 Percent of Dominant Species That Are OBL, FACW, or FAC: 0.0% (A/B)

=Total Cover
 50% of total cover: _____ 20% of total cover: _____

Prevalence Index worksheet:

Total % Cover of:	Multiply by:
OBL species _____	x 1 = _____
FACW species _____	x 2 = _____
FAC species _____	x 3 = _____
FACU species _____	x 4 = _____
UPL species _____	x 5 = _____
Column Totals: _____ (A)	_____ (B)
Prevalence Index = B/A = _____	

Sapling/Shrub Stratum (Plot size: <u>15'R</u>)	Absolute % Cover	Dominant Species?	Indicator Status
1. None			
2.			
3.			
4.			
5.			
6.			
7.			
8.			
9.			

Hydrophytic Vegetation Indicators:

- 1 - Rapid Test for Hydrophytic Vegetation
- 2 - Dominance Test is >50%
- 3 - Prevalence Index is ≤3.0¹
- 4 - Morphological Adaptations¹ (Provide supporting data in Remarks or on a separate sheet)
- Problematic Hydrophytic Vegetation¹ (Explain)

=Total Cover
 50% of total cover: _____ 20% of total cover: _____

¹Indicators of hydric soil and wetland hydrology must be present, unless disturbed or problematic.

Herb Stratum (Plot size: <u>5'R</u>)	Absolute % Cover	Dominant Species?	Indicator Status
1. <i>Poa pratensis</i>	30	Yes	FACU
2. <i>Taraxacum officinale</i>	25	Yes	FACU
3. <i>Trifolium repens</i>	20	Yes	FACU
4. <i>Glechoma hederacea</i>	10	No	FACU
5. <i>Zea mays</i>	10	No	UPL
6. <i>Veronica persica</i>	5	No	UPL
7.			
8.			
9.			
10.			
11.			

Definitions of Four Vegetation Strata:

Tree – Woody plants, excluding vines, 3 in. (7.6 cm) or more in diameter at breast height (DBH), regardless of height.
Sapling/Shrub – Woody plants, excluding vines, less than 3 in. DBH and greater than or equal to 3.28 ft (1 m) tall.
Herb – All herbaceous (non-woody) plants, regardless of size, and woody plants less than 3.28 ft tall.
Woody Vine – All woody vines greater than 3.28 ft in height.

100 =Total Cover
 50% of total cover: 50 20% of total cover: 20

Woody Vine Stratum (Plot size: <u>30'R</u>)	Absolute % Cover	Dominant Species?	Indicator Status
1. None			
2.			
3.			
4.			
5.			

=Total Cover
 50% of total cover: _____ 20% of total cover: _____

Hydrophytic Vegetation Present? Yes _____ No X

Remarks: (Include photo numbers here or on a separate sheet.)

SOIL

Sampling Point: SP-002

Profile Description: (Describe to the depth needed to document the indicator or confirm the absence of indicators.)

Depth (inches)	Matrix		Redox Features				Texture	Remarks
	Color (moist)	%	Color (moist)	%	Type ¹	Loc ²		
0-16	7.5YR 4/4	100					Loamy/Clayey	

¹Type: C=Concentration, D=Depletion, RM=Reduced Matrix, MS=Masked Sand Grains. ²Location: PL=Pore Lining, M=Matrix.

Hydric Soil Indicators:		Indicators for Problematic Hydric Soils ³ :	
<input type="checkbox"/> Histosol (A1)	<input type="checkbox"/> Polyvalue Below Surface (S8) (MLRA 147, 148)	<input type="checkbox"/> 2 cm Muck (A10) (MLRA 147)	
<input type="checkbox"/> Histic Epipedon (A2)	<input type="checkbox"/> Thin Dark Surface (S9) (MLRA 147, 148)	<input type="checkbox"/> Coast Prairie Redox (A16)	
<input type="checkbox"/> Black Histic (A3)	<input type="checkbox"/> Loamy Mucky Mineral (F1) (MLRA 136)	<input type="checkbox"/> (MLRA 147, 148)	
<input type="checkbox"/> Hydrogen Sulfide (A4)	<input type="checkbox"/> Loamy Gleyed Matrix (F2)	<input type="checkbox"/> Piedmont Floodplain Soils (F19)	
<input type="checkbox"/> Stratified Layers (A5)	<input type="checkbox"/> Depleted Matrix (F3)	<input type="checkbox"/> (MLRA 136, 147)	
<input type="checkbox"/> 2 cm Muck (A10) (LRR N)	<input type="checkbox"/> Redox Dark Surface (F6)	<input type="checkbox"/> Red Parent Material (F21)	
<input type="checkbox"/> Depleted Below Dark Surface (A11)	<input type="checkbox"/> Depleted Dark Surface (F7)	<input type="checkbox"/> (outside MLRA 127, 147, 148)	
<input type="checkbox"/> Thick Dark Surface (A12)	<input type="checkbox"/> Redox Depressions (F8)	<input type="checkbox"/> Very Shallow Dark Surface (F22)	
<input type="checkbox"/> Sandy Mucky Mineral (S1)	<input type="checkbox"/> Iron-Manganese Masses (F12) (LRR N, MLRA 136)	<input type="checkbox"/> Other (Explain in Remarks)	
<input type="checkbox"/> Sandy Gleyed Matrix (S4)	<input type="checkbox"/> Umbric Surface (F13) (MLRA 122, 136)		
<input type="checkbox"/> Sandy Redox (S5)	<input type="checkbox"/> Piedmont Floodplain Soils (F19) (MLRA 148)		
<input type="checkbox"/> Stripped Matrix (S6)	<input type="checkbox"/> Red Parent Material (F21) (MLRA 127, 147, 148)		
<input type="checkbox"/> Dark Surface (S7)			

³Indicators of hydrophytic vegetation and wetland hydrology must be present, unless disturbed or problematic.

Restrictive Layer (if observed):

Type: _____

Depth (inches): _____

Hydric Soil Present? Yes _____ No X

Remarks:

U.S. Army Corps of Engineers WETLAND DETERMINATION DATA SHEET – Eastern Mountains and Piedmont Region See ERDC/EL TR-12-9; the proponent agency is CECW-CO-R	OMB Control #: 0710-0024, Exp:11/30/2024 Requirement Control Symbol EXEMPT: (Authority: AR 335-15, paragraph 5-2a)
--	--

Project/Site: Grand Point-Guilford 138kV Line City/County: Franklin Sampling Date: 5/30/24
 Applicant/Owner: FirstEnergy Service Company State: PA Sampling Point: SP-003
 Investigator(s): AFG, JMP Section, Township, Range: Guilford
 Landform (hillside, terrace, etc.): Plain Local relief (concave, convex, none): None Slope (%): 0-1
 Subregion (LRR or MLRA): LRR N Lat: 39.901765 Long: -77.634588 Datum: NAD 83
 Soil Map Unit Name: Hagerstown silt loam, 3 to 8 percent slopes; HcB NWI classification: None

Are climatic / hydrologic conditions on the site typical for this time of year? Yes X No (If no, explain in Remarks.)
 Are Vegetation No, Soil No, or Hydrology No significantly disturbed? Are "Normal Circumstances" present? Yes X No
 Are Vegetation No, Soil No, or Hydrology No naturally problematic? (If needed, explain any answers in Remarks.)

SUMMARY OF FINDINGS – Attach site map showing sampling point locations, transects, important features, etc.

Hydrophytic Vegetation Present? Yes <u> </u> No <u>X</u> Hydric Soil Present? Yes <u> </u> No <u>X</u> Wetland Hydrology Present? Yes <u> </u> No <u>X</u>	Is the Sampled Area within a Wetland? Yes <u> </u> No <u>X</u>
Remarks: Upland sample point is located in agricultural soy bean field.	

HYDROLOGY

Wetland Hydrology Indicators: Primary Indicators (minimum of one is required; check all that apply)	Secondary Indicators (minimum of two required)
<input type="checkbox"/> Surface Water (A1) <input type="checkbox"/> True Aquatic Plants (B14) <input type="checkbox"/> High Water Table (A2) <input type="checkbox"/> Hydrogen Sulfide Odor (C1) <input type="checkbox"/> Saturation (A3) <input type="checkbox"/> Oxidized Rhizospheres on Living Roots (C3) <input type="checkbox"/> Water Marks (B1) <input type="checkbox"/> Presence of Reduced Iron (C4) <input type="checkbox"/> Sediment Deposits (B2) <input type="checkbox"/> Recent Iron Reduction in Tilled Soils (C6) <input type="checkbox"/> Drift Deposits (B3) <input type="checkbox"/> Thin Muck Surface (C7) <input type="checkbox"/> Algal Mat or Crust (B4) <input type="checkbox"/> Other (Explain in Remarks) <input type="checkbox"/> Iron Deposits (B5) <input type="checkbox"/> Inundation Visible on Aerial Imagery (B7) <input type="checkbox"/> Water-Stained Leaves (B9) <input type="checkbox"/> Aquatic Fauna (B13)	<input type="checkbox"/> Surface Soil Cracks (B6) <input type="checkbox"/> Sparsely Vegetated Concave Surface (B8) <input type="checkbox"/> Drainage Patterns (B10) <input type="checkbox"/> Moss Trim Lines (B16) <input type="checkbox"/> Dry-Season Water Table (C2) <input type="checkbox"/> Crayfish Burrows (C8) <input type="checkbox"/> Saturation Visible on Aerial Imagery (C9) <input type="checkbox"/> Stunted or Stressed Plants (D1) <input type="checkbox"/> Geomorphic Position (D2) <input type="checkbox"/> Shallow Aquitard (D3) <input type="checkbox"/> Microtopographic Relief (D4) <input type="checkbox"/> FAC-Neutral Test (D5)

Field Observations: Surface Water Present? Yes <u> </u> No <u>X</u> Depth (inches): <u> </u> Water Table Present? Yes <u> </u> No <u>X</u> Depth (inches): <u> </u> Saturation Present? Yes <u> </u> No <u>X</u> Depth (inches): <u> </u> (includes capillary fringe)	Wetland Hydrology Present? Yes <u> </u> No <u>X</u>
--	---

Describe Recorded Data (stream gauge, monitoring well, aerial photos, previous inspections), if available:

Remarks:

VEGETATION (Four Strata) – Use scientific names of plants.

Sampling Point: SP-003

Tree Stratum (Plot size: <u>30'R</u>)	Absolute % Cover	Dominant Species?	Indicator Status
1. None			
2.			
3.			
4.			
5.			
6.			
7.			
=Total Cover			
50% of total cover: _____ 20% of total cover: _____			

Sapling/Shrub Stratum (Plot size: <u>15'R</u>)	Absolute % Cover	Dominant Species?	Indicator Status
1. None			
2.			
3.			
4.			
5.			
6.			
7.			
8.			
9.			
=Total Cover			
50% of total cover: _____ 20% of total cover: _____			

Herb Stratum (Plot size: <u>5'R</u>)	Absolute % Cover	Dominant Species?	Indicator Status
1. <u>Glycine max</u>	80	Yes	UPL
2.			
3.			
4.			
5.			
6.			
7.			
8.			
9.			
10.			
11.			
80 =Total Cover			
50% of total cover: <u>40</u> 20% of total cover: <u>16</u>			

Woody Vine Stratum (Plot size: <u>30'R</u>)	Absolute % Cover	Dominant Species?	Indicator Status
1. None			
2.			
3.			
4.			
5.			
=Total Cover			
50% of total cover: _____ 20% of total cover: _____			

Dominance Test worksheet:

Number of Dominant Species That Are OBL, FACW, or FAC: 0 (A)

Total Number of Dominant Species Across All Strata: 1 (B)

Percent of Dominant Species That Are OBL, FACW, or FAC: 0.0% (A/B)

Prevalence Index worksheet:

Total % Cover of:	Multiply by:
OBL species _____	x 1 = _____
FACW species _____	x 2 = _____
FAC species _____	x 3 = _____
FACU species _____	x 4 = _____
UPL species _____	x 5 = _____
Column Totals: _____ (A)	_____ (B)
Prevalence Index = B/A = _____	

- Hydrophytic Vegetation Indicators:**
- ___ 1 - Rapid Test for Hydrophytic Vegetation
 - ___ 2 - Dominance Test is >50%
 - ___ 3 - Prevalence Index is ≤3.0¹
 - ___ 4 - Morphological Adaptations¹ (Provide supporting data in Remarks or on a separate sheet)
 - ___ Problematic Hydrophytic Vegetation¹ (Explain)
- ¹Indicators of hydric soil and wetland hydrology must be present, unless disturbed or problematic.

Definitions of Four Vegetation Strata:

Tree – Woody plants, excluding vines, 3 in. (7.6 cm) or more in diameter at breast height (DBH), regardless of height.

Sapling/Shrub – Woody plants, excluding vines, less than 3 in. DBH and greater than or equal to 3.28 ft (1 m) tall.

Herb – All herbaceous (non-woody) plants, regardless of size, and woody plants less than 3.28 ft tall.

Woody Vine – All woody vines greater than 3.28 ft in height.

Hydrophytic Vegetation Present? Yes _____ No X

Remarks: (Include photo numbers here or on a separate sheet.)

SOIL

Sampling Point: SP-003

Profile Description: (Describe to the depth needed to document the indicator or confirm the absence of indicators.)

Depth (inches)	Matrix		Redox Features				Texture	Remarks
	Color (moist)	%	Color (moist)	%	Type ¹	Loc ²		
0-3	10YR 5/6	100					Loamy/Clayey	
3-16	7.5YR 5/6	100					Loamy/Clayey	

¹Type: C=Concentration, D=Depletion, RM=Reduced Matrix, MS=Masked Sand Grains.

²Location: PL=Pore Lining, M=Matrix.

Hydric Soil Indicators:

- Histosol (A1)
- Histic Epipedon (A2)
- Black Histic (A3)
- Hydrogen Sulfide (A4)
- Stratified Layers (A5)
- 2 cm Muck (A10) (**LRR N**)
- Depleted Below Dark Surface (A11)
- Thick Dark Surface (A12)
- Sandy Mucky Mineral (S1)
- Sandy Gleyed Matrix (S4)
- Sandy Redox (S5)
- Stripped Matrix (S6)
- Dark Surface (S7)

- Polyvalue Below Surface (S8) (**MLRA 147, 148**)
- Thin Dark Surface (S9) (**MLRA 147, 148**)
- Loamy Mucky Mineral (F1) (**MLRA 136**)
- Loamy Gleyed Matrix (F2)
- Depleted Matrix (F3)
- Redox Dark Surface (F6)
- Depleted Dark Surface (F7)
- Redox Depressions (F8)
- Iron-Manganese Masses (F12) (**LRR N, MLRA 136**)
- Umbric Surface (F13) (**MLRA 122, 136**)
- Piedmont Floodplain Soils (F19) (**MLRA 148**)
- Red Parent Material (F21) (**MLRA 127, 147, 148**)

Indicators for Problematic Hydric Soils³:

- 2 cm Muck (A10) (**MLRA 147**)
- Coast Prairie Redox (A16) (**MLRA 147, 148**)
- Piedmont Floodplain Soils (F19) (**MLRA 136, 147**)
- Red Parent Material (F21) (**outside MLRA 127, 147, 148**)
- Very Shallow Dark Surface (F22)
- Other (Explain in Remarks)

³Indicators of hydrophytic vegetation and wetland hydrology must be present, unless disturbed or problematic.

Restrictive Layer (if observed):

Type: _____
Depth (inches): _____

Hydric Soil Present? Yes _____ No X

Remarks:

U.S. Army Corps of Engineers WETLAND DETERMINATION DATA SHEET – Eastern Mountains and Piedmont Region See ERDC/EL TR-12-9; the proponent agency is CECW-CO-R	OMB Control #: 0710-0024, Exp:11/30/2024 Requirement Control Symbol EXEMPT: (Authority: AR 335-15, paragraph 5-2a)
--	--

Project/Site: Grand Point-Guilford 138kV Line City/County: Franklin Sampling Date: 5/30/24
 Applicant/Owner: FirstEnergy Service Company State: PA Sampling Point: SP-004
 Investigator(s): AFG, JMP Section, Township, Range: Guilford
 Landform (hillside, terrace, etc.): Hillslope Local relief (concave, convex, none): Concave Slope (%): 5-8
 Subregion (LRR or MLRA): LRR N Lat: 39.902017 Long: -77.632340 Datum: NAD 83
 Soil Map Unit Name: Hagerstown silt loam, 3 to 8 percent slopes; HcB NWI classification: None

Are climatic / hydrologic conditions on the site typical for this time of year? Yes X No (If no, explain in Remarks.)
 Are Vegetation No, Soil No, or Hydrology No significantly disturbed? Are "Normal Circumstances" present? Yes X No
 Are Vegetation No, Soil No, or Hydrology No naturally problematic? (If needed, explain any answers in Remarks.)

SUMMARY OF FINDINGS – Attach site map showing sampling point locations, transects, important features, etc.

Hydrophytic Vegetation Present? Yes <u> </u> No <u>X</u> Hydric Soil Present? Yes <u> </u> No <u>X</u> Wetland Hydrology Present? Yes <u> </u> No <u>X</u>	Is the Sampled Area within a Wetland? Yes <u> </u> No <u>X</u>
Remarks: Upland sample point is located in agricultural soy bean field.	

HYDROLOGY

Wetland Hydrology Indicators: Primary Indicators (minimum of one is required; check all that apply)	Secondary Indicators (minimum of two required)
<input type="checkbox"/> Surface Water (A1) <input type="checkbox"/> True Aquatic Plants (B14) <input type="checkbox"/> High Water Table (A2) <input type="checkbox"/> Hydrogen Sulfide Odor (C1) <input type="checkbox"/> Saturation (A3) <input type="checkbox"/> Oxidized Rhizospheres on Living Roots (C3) <input type="checkbox"/> Water Marks (B1) <input type="checkbox"/> Presence of Reduced Iron (C4) <input type="checkbox"/> Sediment Deposits (B2) <input type="checkbox"/> Recent Iron Reduction in Tilled Soils (C6) <input type="checkbox"/> Drift Deposits (B3) <input type="checkbox"/> Thin Muck Surface (C7) <input type="checkbox"/> Algal Mat or Crust (B4) <input type="checkbox"/> Other (Explain in Remarks) <input type="checkbox"/> Iron Deposits (B5) <input type="checkbox"/> Inundation Visible on Aerial Imagery (B7) <input type="checkbox"/> Water-Stained Leaves (B9) <input type="checkbox"/> Aquatic Fauna (B13)	<input type="checkbox"/> Surface Soil Cracks (B6) <input type="checkbox"/> Sparsely Vegetated Concave Surface (B8) <input type="checkbox"/> Drainage Patterns (B10) <input type="checkbox"/> Moss Trim Lines (B16) <input type="checkbox"/> Dry-Season Water Table (C2) <input type="checkbox"/> Crayfish Burrows (C8) <input type="checkbox"/> Saturation Visible on Aerial Imagery (C9) <input type="checkbox"/> Stunted or Stressed Plants (D1) <input type="checkbox"/> Geomorphic Position (D2) <input type="checkbox"/> Shallow Aquitard (D3) <input type="checkbox"/> Microtopographic Relief (D4) <input type="checkbox"/> FAC-Neutral Test (D5)

Field Observations: Surface Water Present? Yes <u> </u> No <u>X</u> Depth (inches): <u> </u> Water Table Present? Yes <u> </u> No <u>X</u> Depth (inches): <u> </u> Saturation Present? Yes <u> </u> No <u>X</u> Depth (inches): <u> </u> (includes capillary fringe)	Wetland Hydrology Present? Yes <u> </u> No <u>X</u>
--	---

Describe Recorded Data (stream gauge, monitoring well, aerial photos, previous inspections), if available:

Remarks:

VEGETATION (Four Strata) – Use scientific names of plants.

Sampling Point: SP-004

Tree Stratum (Plot size: <u>30'R</u>)	Absolute % Cover	Dominant Species?	Indicator Status
1. None			
2.			
3.			
4.			
5.			
6.			
7.			

Dominance Test worksheet:

Number of Dominant Species That Are OBL, FACW, or FAC: 0 (A)
 Total Number of Dominant Species Across All Strata: 3 (B)
 Percent of Dominant Species That Are OBL, FACW, or FAC: 0.0% (A/B)

=Total Cover
 50% of total cover: _____ 20% of total cover: _____

Prevalence Index worksheet:

Total % Cover of:	Multiply by:
OBL species _____	x 1 = _____
FACW species _____	x 2 = _____
FAC species _____	x 3 = _____
FACU species _____	x 4 = _____
UPL species _____	x 5 = _____
Column Totals: _____ (A)	_____ (B)
Prevalence Index = B/A = _____	

Sapling/Shrub Stratum (Plot size: <u>15'R</u>)	Absolute % Cover	Dominant Species?	Indicator Status
1. None			
2.			
3.			
4.			
5.			
6.			
7.			
8.			
9.			

Hydrophytic Vegetation Indicators:

- 1 - Rapid Test for Hydrophytic Vegetation
- 2 - Dominance Test is >50%
- 3 - Prevalence Index is ≤3.0¹
- 4 - Morphological Adaptations¹ (Provide supporting data in Remarks or on a separate sheet)
- Problematic Hydrophytic Vegetation¹ (Explain)

=Total Cover
 50% of total cover: _____ 20% of total cover: _____

¹Indicators of hydric soil and wetland hydrology must be present, unless disturbed or problematic.

Herb Stratum (Plot size: <u>5'R</u>)	Absolute % Cover	Dominant Species?	Indicator Status
1. <i>Schedonorus arundinaceus</i>	50	Yes	FACU
2. <i>Dactylis glomerata</i>	25	Yes	FACU
3. <i>Lolium perenne</i>	25	Yes	FACU
4.			
5.			
6.			
7.			
8.			
9.			
10.			
11.			

Definitions of Four Vegetation Strata:

Tree – Woody plants, excluding vines, 3 in. (7.6 cm) or more in diameter at breast height (DBH), regardless of height.
Sapling/Shrub – Woody plants, excluding vines, less than 3 in. DBH and greater than or equal to 3.28 ft (1 m) tall.
Herb – All herbaceous (non-woody) plants, regardless of size, and woody plants less than 3.28 ft tall.
Woody Vine – All woody vines greater than 3.28 ft in height.

100 =Total Cover
 50% of total cover: 50 20% of total cover: 20

Woody Vine Stratum (Plot size: <u>30'R</u>)	Absolute % Cover	Dominant Species?	Indicator Status
1. None			
2.			
3.			
4.			
5.			

Hydrophytic Vegetation Present?

Yes _____ No X

Remarks: (Include photo numbers here or on a separate sheet.)

SOIL

Sampling Point: SP-004

Profile Description: (Describe to the depth needed to document the indicator or confirm the absence of indicators.)

Depth (inches)	Matrix		Redox Features				Texture	Remarks
	Color (moist)	%	Color (moist)	%	Type ¹	Loc ²		
0-5	10YR 4/4	100					Loamy/Clayey	silty/clay/loam
5-16	7.5YR 6/6	100					Loamy/Clayey	

¹Type: C=Concentration, D=Depletion, RM=Reduced Matrix, MS=Masked Sand Grains.

²Location: PL=Pore Lining, M=Matrix.

Hydric Soil Indicators:

- Histosol (A1)
- Histic Epipedon (A2)
- Black Histic (A3)
- Hydrogen Sulfide (A4)
- Stratified Layers (A5)
- 2 cm Muck (A10) (**LRR N**)
- Depleted Below Dark Surface (A11)
- Thick Dark Surface (A12)
- Sandy Mucky Mineral (S1)
- Sandy Gleyed Matrix (S4)
- Sandy Redox (S5)
- Stripped Matrix (S6)
- Dark Surface (S7)

- Polyvalue Below Surface (S8) (**MLRA 147, 148**)
- Thin Dark Surface (S9) (**MLRA 147, 148**)
- Loamy Mucky Mineral (F1) (**MLRA 136**)
- Loamy Gleyed Matrix (F2)
- Depleted Matrix (F3)
- Redox Dark Surface (F6)
- Depleted Dark Surface (F7)
- Redox Depressions (F8)
- Iron-Manganese Masses (F12) (**LRR N, MLRA 136**)
- Umbric Surface (F13) (**MLRA 122, 136**)
- Piedmont Floodplain Soils (F19) (**MLRA 148**)
- Red Parent Material (F21) (**MLRA 127, 147, 148**)

Indicators for Problematic Hydric Soils³:

- 2 cm Muck (A10) (**MLRA 147**)
- Coast Prairie Redox (A16) (**MLRA 147, 148**)
- Piedmont Floodplain Soils (F19) (**MLRA 136, 147**)
- Red Parent Material (F21) (**outside MLRA 127, 147, 148**)
- Very Shallow Dark Surface (F22)
- Other (Explain in Remarks)

³Indicators of hydrophytic vegetation and wetland hydrology must be present, unless disturbed or problematic.

Restrictive Layer (if observed):

Type: _____
Depth (inches): _____

Hydric Soil Present? Yes _____ No X

Remarks:

APPENDIX C

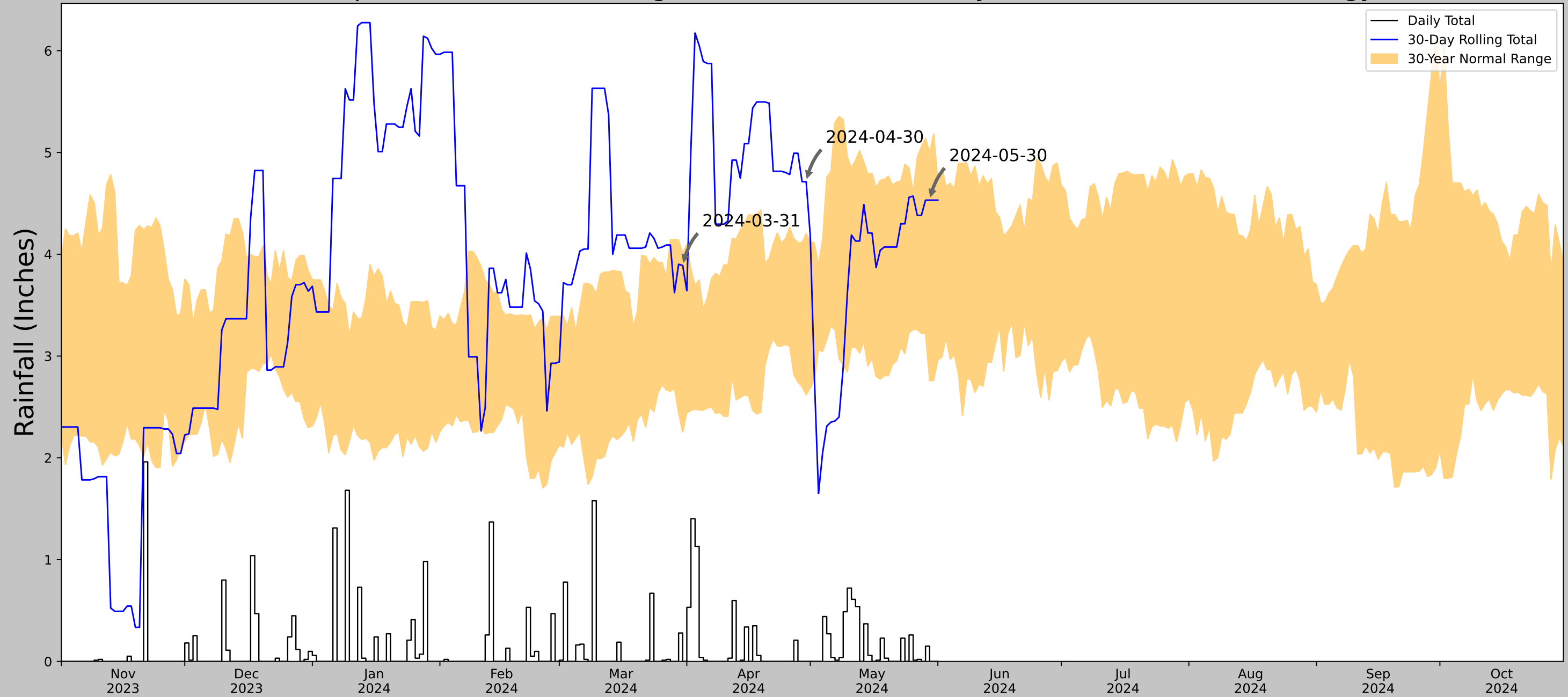

ANTECEDENT PRECIPITATION TOOL ANALYSIS

Antecedent Precipitation vs Normal Range based on NOAA's Daily Global Historical Climatology Network



Coordinates	39.9012, -77.6344
Observation Date	2024-05-30
Elevation (ft)	744.61
Drought Index (PDSI)	Incipient wetness (2024-04)
WebWIMP H ₂ O Balance	Wet Season

30 Days Ending	30 th %ile (in)	70 th %ile (in)	Observed (in)	Wetness Condition	Condition Value	Month Weight	Product
2024-05-30	2.756299	5.003937	4.531496	Normal	2	3	6
2024-04-30	2.619291	4.20315	4.712599	Wet	3	2	6
2024-03-31	2.251575	4.007874	3.889764	Normal	2	1	2
Result							Normal Conditions - 14

 Figures and tables made by the Antecedent Precipitation Tool Version 2.0
 Developed by:
 U.S. Army Corps of Engineers and
 U.S. Army Engineer Research and Development Center

Weather Station Name	Coordinates	Elevation (ft)	Distance (mi)	Elevation Δ	Weighted Δ	Days Normal	Days Antecedent
SHIPPENSBURG	40.0592, -77.5214	680.118	12.449	64.492	6.405	11351	85
SHIPPENSBURG 1.9 E	40.0504, -77.4876	688.976	1.888	8.858	0.866	0	5
CHAMBERSBURG 1 ESE	39.9353, -77.6394	640.092	10.597	40.026	5.193	1	0

1. PROJECT INFORMATION

Project Name: **Grand Point-Guilford 138kV Line**

Date of Review: **7/22/2024 09:47:25 AM**

Project Category: **Energy Storage, Production, and Transfer, Energy Transfer, Power/electric line - service, replace existing above/under-ground line**

Project Area: **14.72 acres**

County(s): **Franklin**

Township/Municipality(s): **GUILFORD TOWNSHIP**

ZIP Code:

Quadrangle Name(s): **CHAMBERSBURG**

Watersheds HUC 8: **Conococheague-Opequon**

Watersheds HUC 12: **Falling Spring Branch-Conococheague Creek**

Decimal Degrees: **39.901227, -77.634553**

Degrees Minutes Seconds: **39° 54' 4.4163" N, 77° 38' 4.3902" W**

2. SEARCH RESULTS

Agency	Results	Response
PA Game Commission	No Known Impact	No Further Review Required
PA Department of Conservation and Natural Resources	No Known Impact	No Further Review Required
PA Fish and Boat Commission	No Known Impact	No Further Review Required
U.S. Fish and Wildlife Service	No Known Impact	No Further Review Required

As summarized above, Pennsylvania Natural Diversity Inventory (PNDI) records indicate no known impacts to threatened and endangered species and/or special concern species and resources within the project area. Therefore, based on the information you provided, no further coordination is required with the jurisdictional agencies. This response does not reflect potential agency concerns regarding impacts to other ecological resources, such as wetlands.

Grand Point-Guilford 138kV Line



-  Buffered Project Boundary
-  Project Boundary



Sources: Esri, Airbus DS, USGS, NGA, NASA, CGIAR, N Robinson, NCEAS, NLS, OS, NMA, Geodatastyrelsen, Rijkswaterstaat, GSA, Geoland, FEMA, Intermap and the GIS user community

Grand Point-Guilford 138kV Line

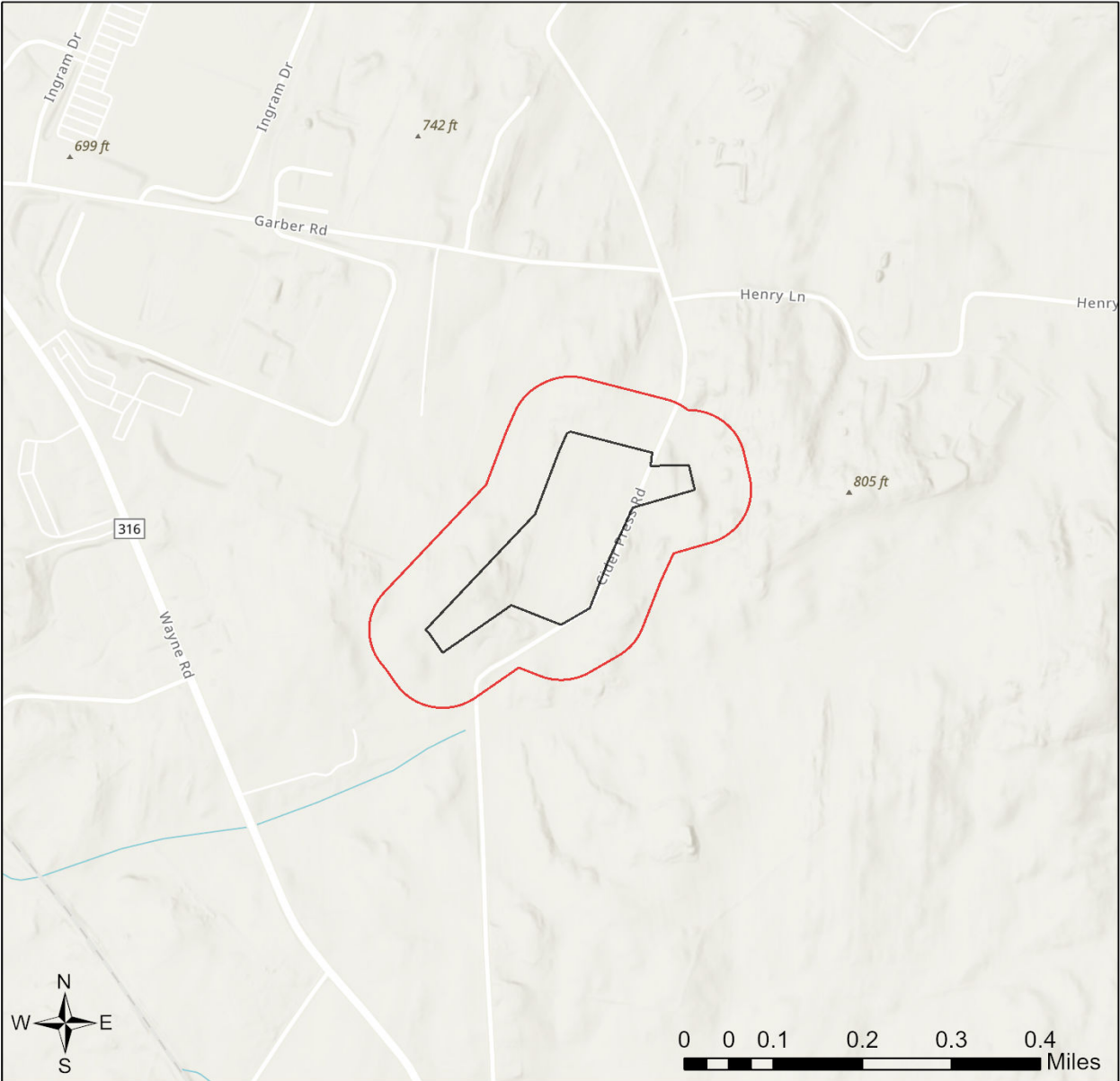

- ▭ Buffered Project Boundary
- Project Boundary



Sources: Esri, Airbus DS, USGS, NGA, NASA, CGIAR, N Robinson, NCEAS, NLS, OS, NMA, Geodatastyrelsen, Rijkswaterstaat, GSA, Geoland, FEMA, Intermap and the GIS user community

3. AGENCY COMMENTS

Regardless of whether a DEP permit is necessary for this proposed project, any potential impacts to threatened and endangered species and/or special concern species and resources must be resolved with the appropriate jurisdictional agency. In some cases, a permit or authorization from the jurisdictional agency may be needed if adverse impacts to these species and habitats cannot be avoided.

These agency determinations and responses are **valid for two years** (from the date of the review), and are based on the project information that was provided, including the exact project location; the project type, description, and features; and any responses to questions that were generated during this search. If any of the following change: 1) project location, 2) project size or configuration, 3) project type, or 4) responses to the questions that were asked during the online review, the results of this review are not valid, and the review must be searched again via the PNDI Environmental Review Tool and resubmitted to the jurisdictional agencies. The PNDI tool is a primary screening tool, and a desktop review may reveal more or fewer impacts than what is listed on this PNDI receipt. The jurisdictional agencies **strongly advise against** conducting surveys for the species listed on the receipt prior to consultation with the agencies.

PA Game Commission

RESPONSE:

No Impact is anticipated to threatened and endangered species and/or special concern species and resources.

PA Department of Conservation and Natural Resources

RESPONSE:

No Impact is anticipated to threatened and endangered species and/or special concern species and resources.

PA Fish and Boat Commission

RESPONSE:

No Impact is anticipated to threatened and endangered species and/or special concern species and resources.

U.S. Fish and Wildlife Service

RESPONSE:

No impacts to **federally** listed or proposed species are anticipated. Therefore, no further consultation/coordination under the Endangered Species Act (87 Stat. 884, as amended; 16 U.S.C. 1531 et seq. is required. Because no take of federally listed species is anticipated, none is authorized. This response does not reflect potential Fish and Wildlife Service concerns under the Fish and Wildlife Coordination Act or other authorities.

4. DEP INFORMATION

The Pa Department of Environmental Protection (DEP) requires that a signed copy of this receipt, along with any required documentation from jurisdictional agencies concerning resolution of potential impacts, be submitted with applications for permits requiring PNDI review. Two review options are available to permit applicants for handling PNDI coordination in conjunction with DEP's permit review process involving either T&E Species or species of special concern. Under sequential review, the permit applicant performs a PNDI screening and completes all coordination with the appropriate jurisdictional agencies prior to submitting the permit application. The applicant will include with its application, both a PNDI receipt and/or a clearance letter from the jurisdictional agency if the PNDI Receipt shows a Potential Impact to a species or the applicant chooses to obtain letters directly from the jurisdictional agencies. Under concurrent review, DEP, where feasible, will allow technical review of the permit to occur concurrently with the T&E species consultation with the jurisdictional agency. The applicant must still supply a copy of the PNDI Receipt with its permit application. The PNDI Receipt should also be submitted to the appropriate agency according to directions on the PNDI Receipt. The applicant and the jurisdictional agency will work together to resolve the potential impact(s). See the DEP PNDI policy at <https://conservationexplorer.dcnr.pa.gov/content/resources>.

5. ADDITIONAL INFORMATION

The PNDI environmental review website is a preliminary screening tool. There are often delays in updating species status classifications. Because the proposed status represents the best available information regarding the conservation status of the species, state jurisdictional agency staff give the proposed statuses at least the same consideration as the current legal status. If surveys or further information reveal that a threatened and endangered and/or special concern species and resources exist in your project area, contact the appropriate jurisdictional agency/agencies immediately to identify and resolve any impacts.

For a list of species known to occur in the county where your project is located, please see the species lists by county found on the PA Natural Heritage Program (PNHP) home page (www.naturalheritage.state.pa.us). Also note that the PNDI Environmental Review Tool only contains information about species occurrences that have actually been reported to the PNHP.

6. AGENCY CONTACT INFORMATION

PA Department of Conservation and Natural Resources

Bureau of Forestry, Ecological Services Section
 400 Market Street, PO Box 8552
 Harrisburg, PA 17105-8552
 Email: RA-HeritageReview@pa.gov

PA Fish and Boat Commission

Division of Environmental Services
 595 E. Rolling Ridge Dr., Bellefonte, PA 16823
 Email: RA-FBPACENOTIFY@pa.gov

U.S. Fish and Wildlife Service

Pennsylvania Field Office
 Endangered Species Section
 110 Radnor Rd; Suite 101
 State College, PA 16801
 Email: IR1_ESPenn@fws.gov
 NO Faxes Please

PA Game Commission

Bureau of Wildlife Management
 Division of Environmental Review
 2001 Elmerton Avenue, Harrisburg, PA 17110-9797
 Email: RA-PGC_PNDI@pa.gov
 NO Faxes Please

7. PROJECT CONTACT INFORMATION

Name: McKenzie McKeon
 Company/Business Name: Civil & Environmental Consultants, Inc.
 Address: 700 Cherrington Parkway
 City, State, Zip: Moon Township, PA 15108
 Phone: (412) 429-2324 Fax: ()
 Email: mmckeon@cecinc.com

8. CERTIFICATION

I certify that ALL of the project information contained in this receipt (including project location, project size/configuration, project type, answers to questions) is true, accurate and complete. In addition, if the project type, location, size or configuration changes, or if the answers to any questions that were asked during this online review change, I agree to re-do the online environmental review.

 applicant/project proponent signature

7/22/2024
 date



July 26, 2024

Sent Via PA-SHARE

RE: ER Project # 2024PR03488.001, Grand Point - Guilford 138kV Station, PA Utility Commission, Guilford Township, Franklin County

Dear Submitter,

Thank you for submitting information concerning the above referenced project. The Pennsylvania State Historic Preservation Office (PA SHPO) reviews projects in accordance with state and federal laws. Section 106 of the National Historic Preservation Act of 1966, and the implementing regulations (36 CFR Part 800) of the Advisory Council on Historic Preservation, is the primary federal legislation. The Environmental Rights amendment, Article 1, Section 27 of the Pennsylvania Constitution and the Pennsylvania History Code, 37 Pa. Cons. Stat. Section 500 et seq. (1988) is the primary state legislation. These laws include consideration of the project's potential effects on both historic and archaeological resources.

Above Ground Resources

No Above Ground Concerns - Environmental Review - No Effect - Above Ground

Based on the information received and available within our files, it is our opinion that the proposed project will have No Effect on above ground historic properties, including historic buildings, districts, structures, and/or objects, should they exist. Should the scope of the project change and/or should you be made aware of historic property concerns, you will need to reinitiate consultation with our office using PA-SHARE.

For questions concerning above ground resources, please contact Sara-Ladd Manley at samanley@pa.gov.

Archaeological Resources

No Archaeological Concerns - Environmental Review - No Effect - Archaeological

Based on the information received and available in our files, in our opinion, the proposed project should have No Effect on archaeological resources. Should the scope of the project be amended to include additional ground-disturbing activity and/or should you be made aware of historic property concerns regarding archaeological resources, you will need to reinitiate consultation with our office using PA-SHARE.

For questions concerning archaeological resources, please contact Sara-Ladd Manley at samanley@pa.gov.

Sincerely,

A handwritten signature in black ink, appearing to read "Emma Diehl". The signature is fluid and cursive, with a long horizontal stroke at the end.

Emma Diehl
Environmental Review Division Manager

**BEFORE THE
PENNSYLVANIA PUBLIC UTILITY COMMISSION**

**JOINT LETTER OF NOTIFICATION :
FILING OF KEYSTONE APPALACHIAN :
TRANSMISSION COMPANY AND :
FIRSTENERGY PENNSYLVANIA :
ELECTRIC COMPANY FOR THE GRAND : Docket No. _____
POINT-GUILFORD 138 KILOVOLT :
TRANSMISSION LINE TAP TO CIDER :
PRESS SUBSTATION PROJECT IN :
GUILFORD TOWNSHIP, FRANKLIN :
COUNTY, PENNSYLVANIA :**

CERTIFICATE OF SERVICE

I hereby certify that on this date, the parties listed below that are entitled to receive a Letter of Notification pursuant to 52 Pa. Code §§ 57.72(d)(3) and 57.74(b) were served by certified mail, return receipt requested, a copy of the above-captioned Joint Letter of Notification Filing, and the parties listed below that are entitled to receive a Notice of Filing pursuant to 52 Pa. Code § 57.74(c)(1) were served by certified mail, return receipt requested, a copy of the Notice of Filing and a courtesy copy of the Joint Letter of Notification.

Service by certified mail, return receipt requested, addressed as follows:

Those entitled to receive a Letter of Notification:

Pursuant to 52 Pa. Code § 57.74(b)(1) - The chief executive officer, the governing body and the body charged with the duty of planning land use in each city, borough, town, township, and county in which any portion of the HV line is proposed to be located:

Franklin County

Commissioner Dean Horst
Chairman, Franklin County
Board of Commissioners
272 North Second Street
Chambersburg, PA 17201

Commissioner Robert Ziobrowski
Member, Franklin County
Board of Commissioners
272 North Second Street
Chambersburg, PA 17201

Commissioner John Flannery
Member, Franklin County
Board of Commissioners
272 North Second Street
Chambersburg, PA 17201

Quentin Clapper
Planning Director
Franklin County Planning Commission
272 North Second Street
Chambersburg, PA 17201

Guilford Township

Donald C. Clapper
Chair, Guilford Township
Board of Supervisors
115 Spring Valley Road
Chambersburg, PA 17202

Michael Ferguson
Member, Guilford Township
Board of Supervisors
115 Spring Valley Road
Chambersburg, PA 17202

Theodore Bittinger
Member, Guilford Township
Board of Supervisors
115 Spring Valley Road
Chambersburg, PA 17202

Greg Lebo
Engineer, Guilford Township
Brehm-Lebo Engineering, Inc.
17 State Avenue
Carlisle, PA 17013

William Green
Chairman, Guilford Township
Planning Commission
115 Spring Valley Road
Chambersburg, PA 17202

Pursuant to 52 Pa. Code § 57.74(b)(2) - The president of the public utility, other than the applicant, in whose service territory any portion of the HV line is proposed to be located:

NOT APPLICABLE

Pursuant to 52 Pa. Code § 57.74(b)(3) – The Department of Environmental Resources:

PA Department of Environmental Protection
ATTN: Office of Chief Counsel
400 Market St., 9th Floor
Harrisburg, PA 17105
CC: Secretary to PADEP Chief Counsel

PA Department of Environmental Protection
ATTN: Bureau of Waterways Engineering and
Wetlands
400 Market Street
Harrisburg, PA 17101

Pursuant to 52 Pa. Code § 5.14(b) and the Pennsylvania Public Utility Commission’s Secretarial Letter issued July 27, 2018:

Via electronic mail only:

Via electronic mail only:

Office of Consumer Advocate
555 Walnut Street
5th Floor Forum Place
Harrisburg, PA 17101-1923
Via electronic mail only:

Office of Small Business Advocate
Suite 1102, Commerce Building
300 North Second Street
Harrisburg, PA 17101

Pennsylvania Public Utility Commission
Bureau of Investigation and Enforcement
P.O. Box 3265
Harrisburg, PA 17105-3265

Those entitled to receive a Notice of Filing:

Pursuant to 52 Pa. Code § 57.74(c)(1)(i) – The Secretary of the Department of Transportation:

Office of Chief Counsel Real Property Division
Pennsylvania Department of Transportation
Commonwealth Keystone Building
400 North Street, 9th Floor
Harrisburg, PA 17120

Pursuant to 52 Pa. Code § 57.74(c)(1)(ii) – The Chairman of the Historical and Museum Commission:

Ms. Andrea Lowery, Executive Director
Pennsylvania Historical & Museum Commission
300 North Street
Harrisburg, PA 17120-0024

Pursuant to 52 Pa. Code § 57.74(c)(1)(iii) – Other local, State or Federal agencies designated in § 57.72(c)(11):

Dave Stoner
District Manager
Franklin County Conservation District
185 Franklin Farm Lane
Chambersburg, PA 17202

Pursuant to 52 Pa. Code § 57.74(c)(1)(iv) – Known persons, corporations and other entities of record owning property within the proposed right-of-way:

Martin's Famous Pastry Shoppe, Inc.
1000 Potato Roll Lane
Chambersburg, PA 17202

Date: February 5, 2025

By: 

Joey T. Chen
Attorney No. 334709
76 South Main St.
Akron, OH 44308
(610) 921-6784
jchen@firstenergycorp.com

Counsel for Keystone Appalachian Transmission
Company and FirstEnergy Pennsylvania Electric
Company