

CERTIFIED CORRECT PLANS
Will M. D. P.E.
 Professional Engineer
 Approved by Bureau of Technical Utility Services
PA PUBLIC UTILITY COMMISSION
 ATTEST *Rosemary Chinitz*
 Secretary

- FIELD TO VERIFY ALL MEASUREMENTS
 * - GATE READY

Exhibit "C"
 Page 1 of 7

- NOTES:**
- MATERIAL & INSTALLATION TO BE IN ACCORDANCE WITH MUTCD, STATE AND RAILROAD STANDARDS.
 - ALL DIMENSIONS ARE APPROXIMATE AND MAY VARY DUE TO ACTUAL FIELD CONDITIONS.
 - ALL FLASHING LIGHT SIGNALS TO BE LIGHT EMITTING DIODE (LED)
 - Ⓞ DENTIES TWIST PAIR.
 - ISLAND CIRCUIT MUST BE A MINIMUM OF 120' IN LENGTH

CABLE RUN TABULATION

HOUSE TO SIGNAL #1 (GATE READY)	- 7/C #6 UG CABLE
	- 7/C #14 UG CABLE
HOUSE TO SIGNAL #2 (GATE READY)	- 7/C #6 UG CABLE
	- 7/C #14 UG CABLE
HOUSE TO AC SERVICE	- 3/C #6 UG CABLE
HOUSE TO 1TN & 1TB	- 2/C #6 TW, PAIR UG CABLE
HOUSE TO 2TN & 2TB	- 2/C #6 TW, PAIR UG CABLE
HOUSE TO 3TN & 3TB	- 2/C #6 TW, PAIR UG CABLE

DIAMONDBACK SIGNAL
 (410) 795-9601
 5965 EXCHANGE DRIVE
 SUITE "D"
 SYKESVILLE, MD
 21784

AS WIRED XX/XX/XXXX		AS INSTALLED XX/XX/XXXX	
EAST PENN RAILROAD RAILROAD CROSSING WARNING DEVICES			
SCALE: NONE	APPROVED BY:	DRAWN BY: NST	
DATE: 08/07/24		REVISED:	
LAKE ROAD EAST DOT # 541 211P MP. 39.30 AVONDALE, CHESTER COUNTY, PA			
TRACK & CABLE PLAN			DRAWING NUMBER

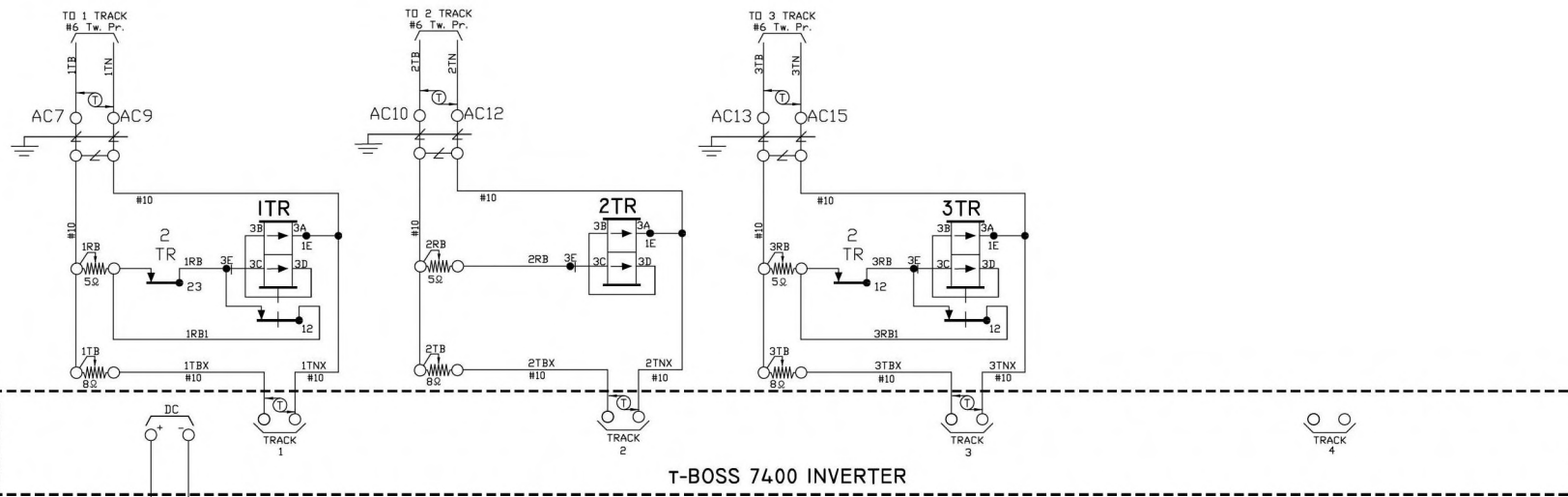

T-BOSS 7400 INVERTER

WARNING
 PLACING SWITCH TO THE OUT-OF-SERVICE POSITION COMPLETELY DISABLES THIS HIGHWAY CROSSING WARNING SYSTEM. PROPER AUTHORITIES MUST BE NOTIFIED PRIOR TO OUT-OF-SERVICE.

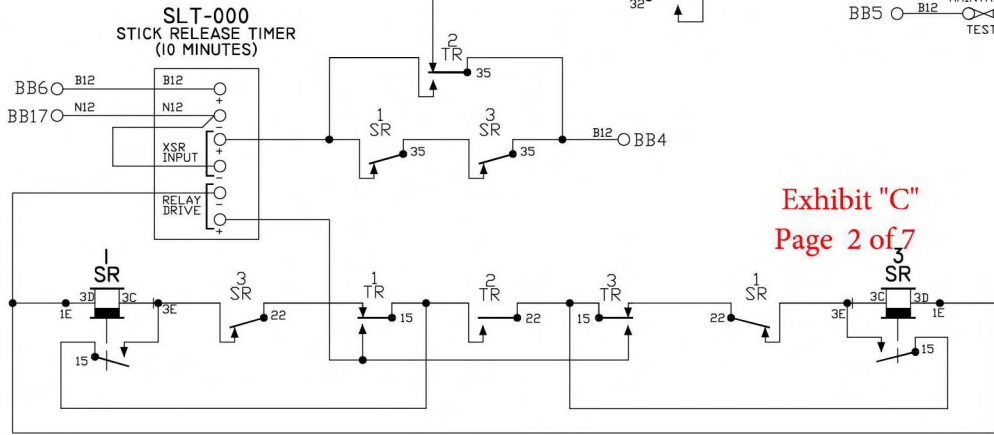
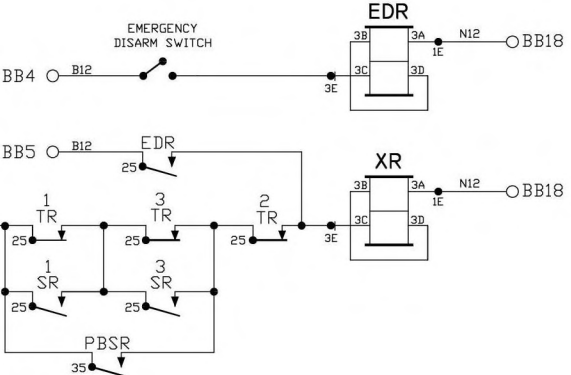
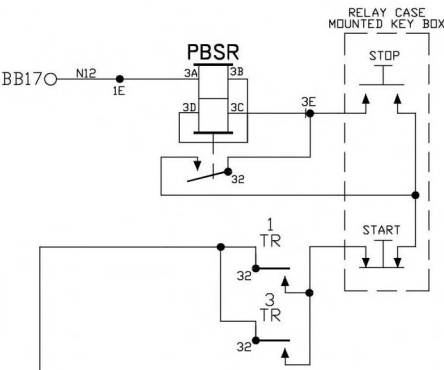
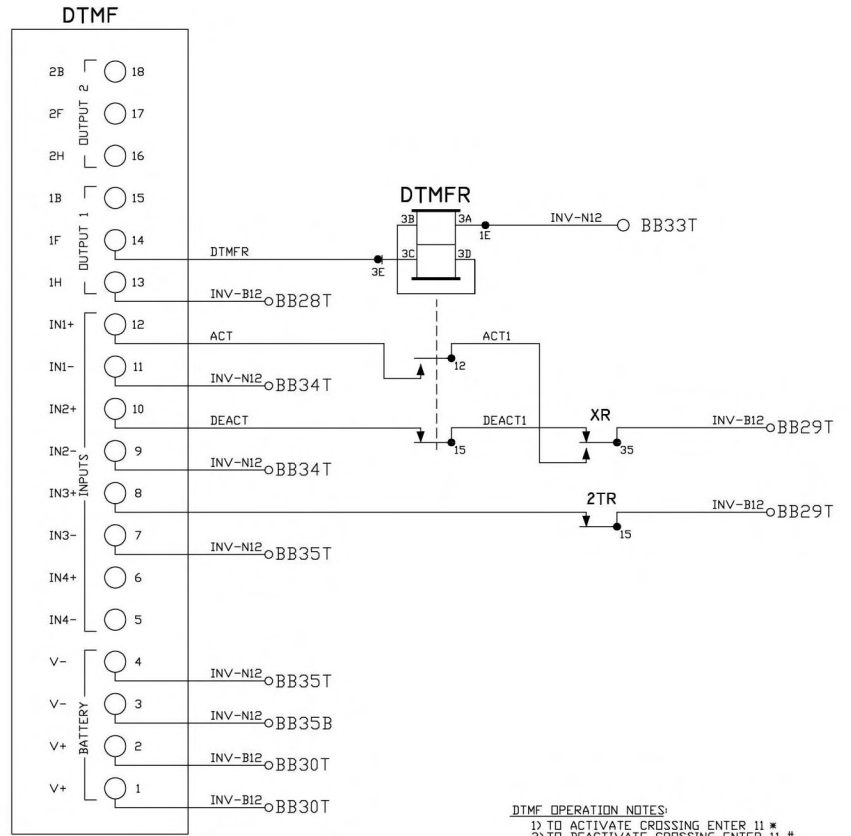

Exhibit "C"
 Page 2 of 7

- NOTES:
1. ALL WIRE THIS SHEET IS #14 AWG FLEX UNLESS OTHERWISE NOTED.
 2. (TW) DENOTES TWISTED PAIR.

AS WIRED XX/XX/XXXX		AS INSTALLED XX/XX/XXXX	
DIAMONDBACK SIGNAL			
EAST PENN RAILROAD RAILROAD CROSSING WARNING DEVICES			
SCALE: NONE	APPROVED BY:	DRAWN BY: NST	
DATE: 08/07/24		REVISED:	
LAKE ROAD EAST DOT # 541 211P MP. 39.30 AVONDALE, CHESTER COUNTY, PA			
CIRCUIT PLAN "A"			DRAWING NUMBER



DTMF OPERATION NOTES:
 1) TO ACTIVATE CROSSING ENTER 11 *
 2) TO DEACTIVATE CROSSING ENTER 11 #
 3) 10 MINUTE TIME OUT
 4) INPUT 3 RESETS

CONSTRUCTION NOTE:
 ☆ - FIELD TO PROVIDE DTMF CHANNEL BETWEEN 1 AND 8.

☆ CHANNEL FREQUENCY-160.545

NOTE:
 1. ALL WIRE THIS SHEET IS #14 AWG FLEX UNLESS OTHERWISE NOTED.

Exhibit "C"
Page 3 of 7

SHEET 3 OF 7

AS WIRED XX/XX/XXXX		AS INSTALLED XX/XX/XXXX	
DIAMONDBACK SIGNAL			
EAST PENN RAILROAD RAILROAD CROSSING WARNING DEVICES			
SCALE: NONE	APPROVED BY:	DRAWN BY: NST	
DATE: 08/07/24		REVISED:	
LAKE ROAD EAST DOT # 541 21IP MP. 39.30 AVONDALE, CHESTER COUNTY, PA			
CIRCUIT PLAN "B"			DRAWING NUMBER

(410) 795-9601
 5965 EXCHANGE DRIVE
 SUITE "D"
 SYKESVILLE, MD
 21784

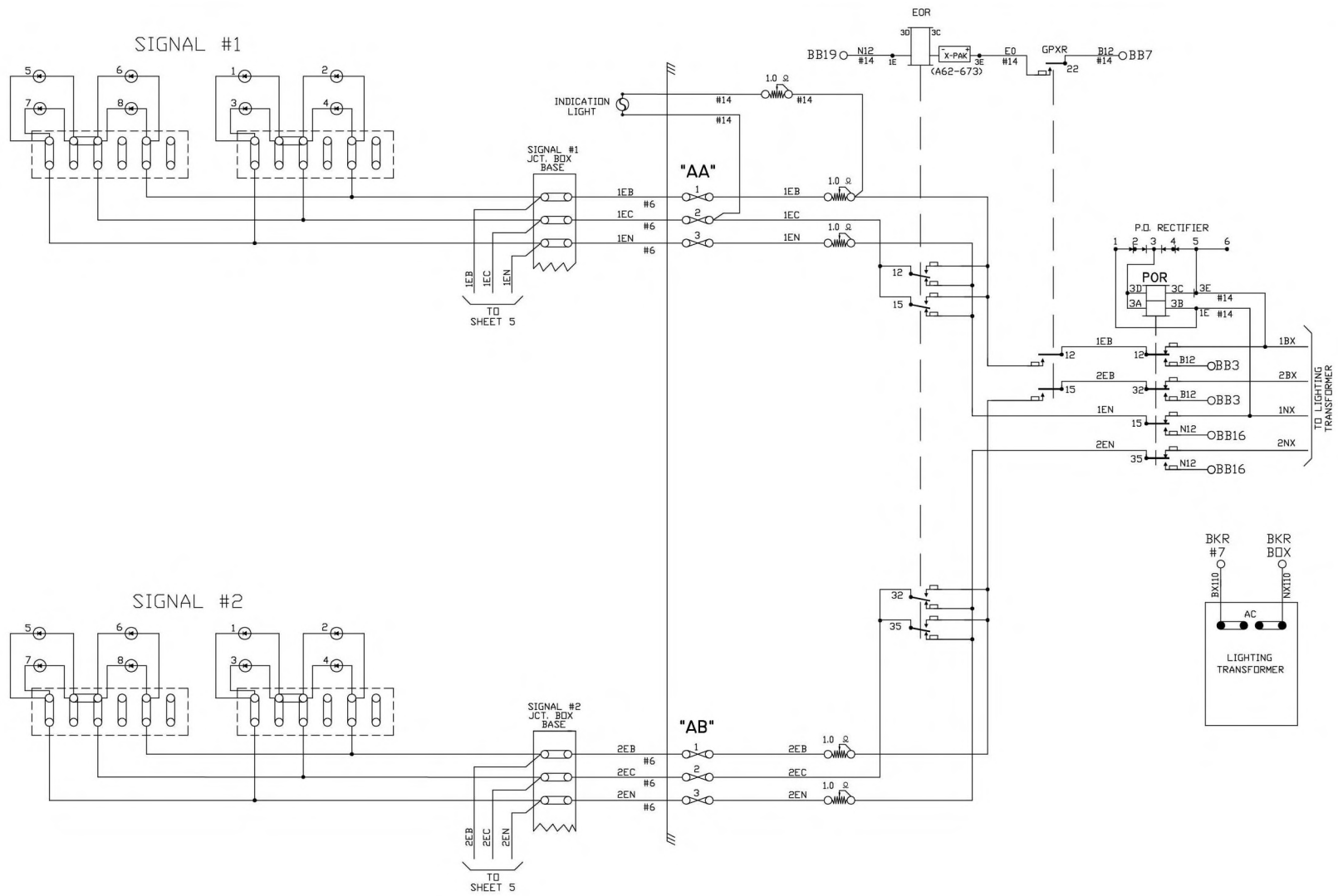

- NOTES:
1. ALL WIRE THIS SHEET IS #10 AWG. FLEX UNLESS OTHERWISE NOTED.
 2. FLASHER RELAY W/X-PAK (A62-673)

Exhibit "C"
Page 3 of 7

SHEET 4 OF 7

DIAMONDBACK SIGNAL
(410) 795-9601
5965 EXCHANGE DRIVE
SUITE "D"
SYKESVILLE, MD
21784

AS WIRED XX/XX/XXXX		AS INSTALLED XX/XX/XXXX	
EAST PENN RAILROAD RAILROAD CROSSING WARNING DEVICES			
SCALE: NONE	APPROVED BY:	DRAWN BY: NST	
DATE: 08/07/24		REVISED:	
LAKE ROAD EAST DOT # 541 211P MP. 39.30 AVONDALE, CHESTER COUNTY, PA			DRAWING NUMBER
CIRCUIT PLAN "C"			

GATE NO. 1

GATE NO. 2

CONTACT	CLOSED	FUNCTION	TENSION
1B	75-90°	POWER DOWN	18-22 OZ.
1F	0-70°	SNUB DOWN	18-22 OZ.
2	0-86°	POWER UP	18-28 OZ.
4	82-90°	GATE CLEAR	16-24 OZ.
5	10-90°	BELL	16-24 OZ.
6	SPARE	SPARE	16-24 OZ.
7	0-10°	SNUB	16-24 OZ.

FUTURE GATES

WCH3597

WCH3597

DIAMONDBACK SIGNAL

(410) 795-9601
5965 EXCHANGE DRIVE
SUITE "D"
SYKESVILLE, MD
21784

EAST PENN RAILROAD RAILROAD CROSSING WARNING DEVICES			
SCALE: NONE	APPROVED BY:	DRAWN BY: NST	
DATE: 08/07/24		REVISED:	
LAKE ROAD EAST DOT # 541 211P MP. 39.30 AVONDALE, CHESTER COUNTY, PA			
CIRCUIT PLAN "D"			DRAWING NUMBER

NOTE: ALL WIRE ON THIS SHEET IS #10 AWG UNLESS OTHERWISE NOTED

Exhibit "C"
Page 3 of 7

SHEET 5 OF 7

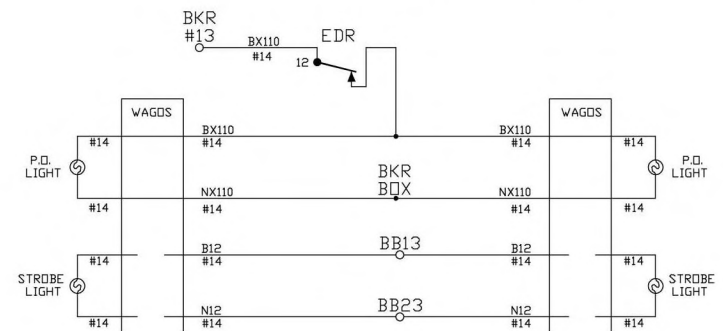
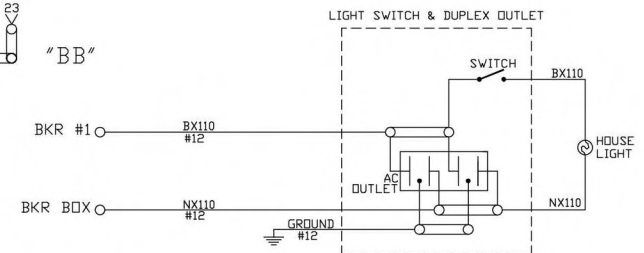
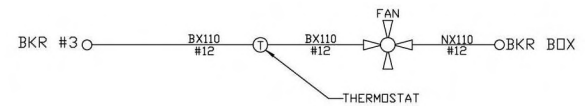
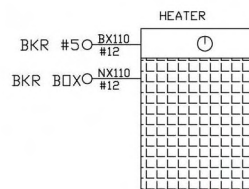
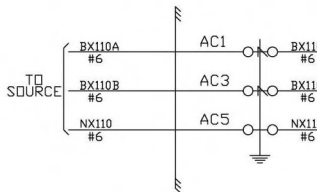
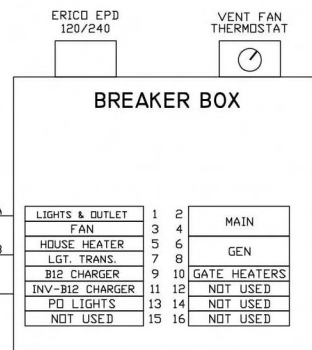
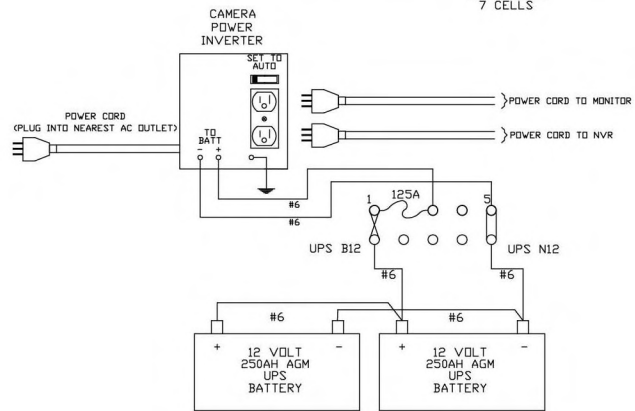
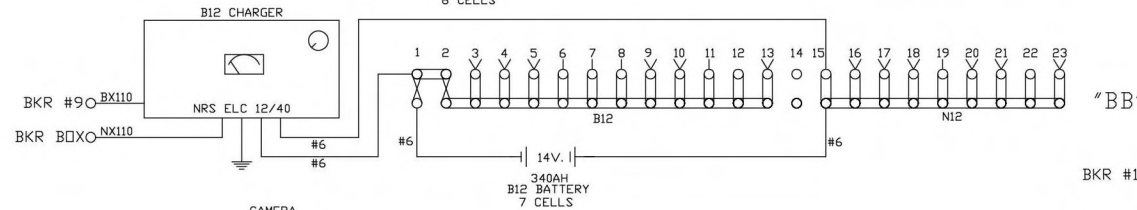
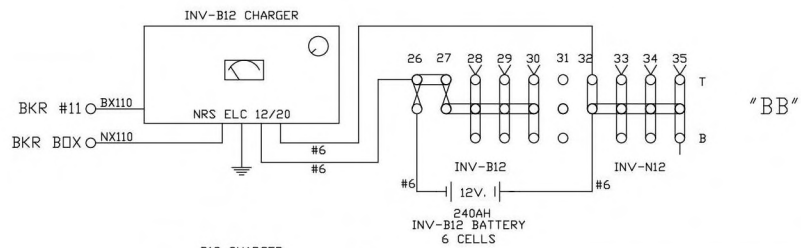

NOTE:
ALL WIRE THIS SHEET IS #10 AWG FLEX
UNLESS OTHERWISE NOTED.

AS WIRED XX/XX/XXXX AS INSTALLED XX/XX/XXXX

DIAMONDBACK SIGNAL

(410) 795-9601
5965 EXCHANGE DRIVE
SUITE "D"
SYKESVILLE, MD
21784

**EAST PENN RAILROAD
RAILROAD CROSSING WARNING DEVICES**

SCALE: NONE APPROVED BY: DRAWN BY: NST
DATE: 08/07/24 REVISED:

LAKE ROAD EAST DOT # 541 211P MP. 39.30
AVONDALE, CHESTER COUNTY, PA

CIRCUIT PLAN "E" DRAWING NUMBER

Exhibit "C"
Page 6 of 7

SHEET 6 OF 7

SIDE "C"

SIDE "A"

SIDE "B"

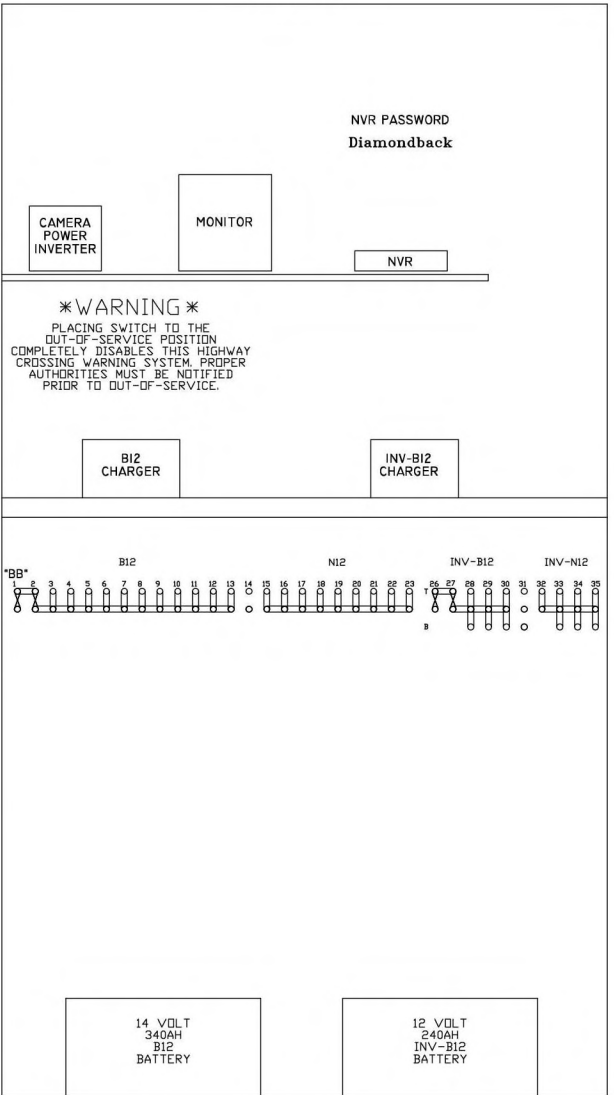
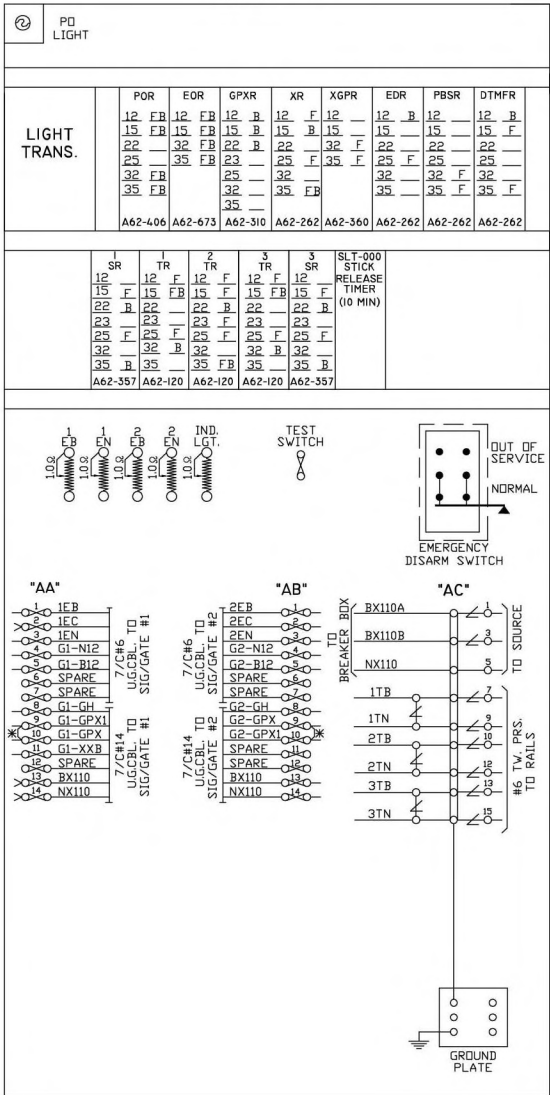
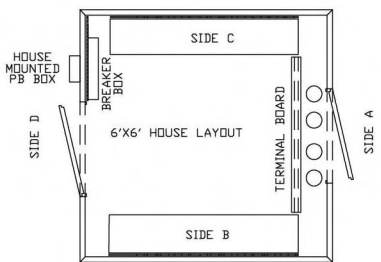
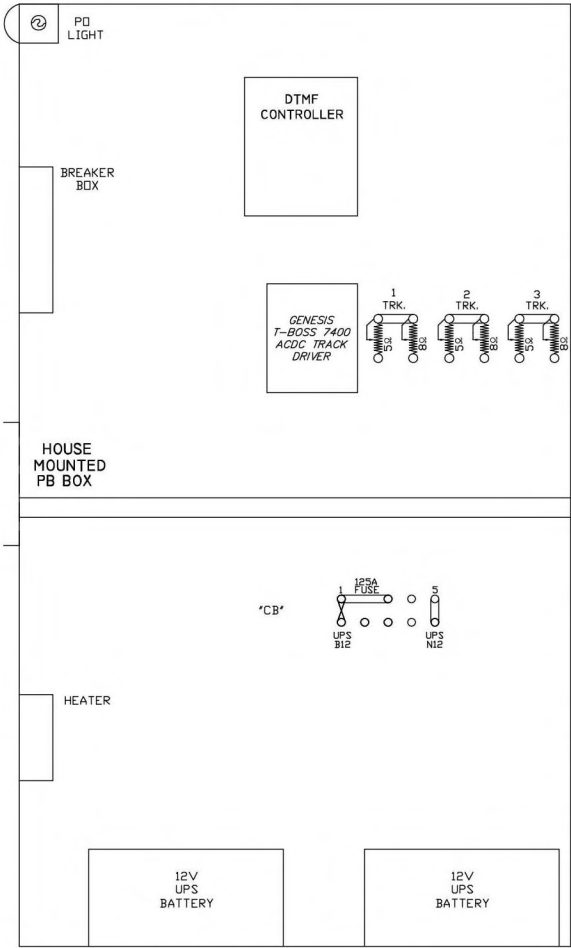

* - TEMPORARY "GATE READY" JUMPER
Exhibit "C"
 Page 7 of 7

DIAMONDBACK SIGNAL
 (410) 795-9601
 5965 EXCHANGE DRIVE
 SUITE "D"
 SYKESVILLE, MD
 21784

AS WIRED XX/XX/XXXX		AS INSTALLED XX/XX/XXXX	
EAST PENN RAILROAD RAILROAD CROSSING WARNING DEVICES			
SCALE: NONE	APPROVED BY:	DRAWN BY: NST	
DATE: 08/07/24		REVISED:	
LAKE ROAD EAST DOT # 541 21IP MP. 39.30 AVONDALE, CHESTER COUNTY, PA			DRAWING NUMBER
RELAY HOUSE LAYOUT			