



May 12, 2025

Rosemary Chiavetta, Secretary  
Pennsylvania Public Utility Commission  
400 North Street  
Harrisburg, PA 17120

**Re: Application of the Department of Transportation of the Commonwealth of Pennsylvania for approval to replace the bridge where Route K091 (Water Street Bridge) crosses above the track(s) of Luzerne County Redevelopment Authority, DOT Number Unknown, and to alter the at-grade crossings where the Riverfront Park Trail crosses the tracks of Luzerne County Redevelopment Authority, DOT Number 924 938R, and where the Private Driveway crosses the tracks of Luzerne County Redevelopment Authority, DOT Number Unknown in the City of Pittston, Luzerne County and the allocation of costs incident thereto.**

Dear Secretary Chiavetta:

Enclosed for filing, please find the Application of the Department of Transportation.

A copy of this Application and Exhibits has been served upon the parties in the Certificate of Service to the Application.

Sincerely,

A handwritten signature in black ink that reads "John E. Pfeiffer". The signature is written in a cursive style and is positioned above a horizontal line.

John E. Pfeiffer  
District Grade Crossing Engineer  
Engineering District 4-0  
Department of Transportation

Attachments

cc: Parties of Record  
M.J. Chappell, P.E., Chief, Right-of-Way, Utilities & Grade Crossing Division  
K. L. Cummings, Senior Counsel, Office of Chief Counsel  
W. M. Sinick, P.E., Supervisor, Rail Safety Engineering Section PUC

**BEFORE THE  
PENNSYLVANIA PUBLIC UTILITY COMMISSION**

Application of the Department of Transportation of the Commonwealth of Pennsylvania for approval to replace the bridge where Water Street Bridge (K091) crosses above the track of Luzerne County Redevelopment Authority, DOT Number Unknown, and to alter the at-grade crossing where the Riverfront Park Trail crosses the tracks of Luzerne County Redevelopment Authority, DOT Number 924 938 R in the City of Pittston, Luzerne County and the allocation of costs incident thereto.

Application  
Docket No. \_\_\_\_\_

**Electronically Filed**

APPLICATION OF THE COMMONWEALTH OF PENNSYLVANIA, DEPARTMENT OF  
TRANSPORTATION

Applicant, Commonwealth of Pennsylvania, Department of Transportation, files this Application pursuant to the provisions of 66 Pa.C.S § 2702 and 52 Pa. Code § 5.13 for the alteration of the public below grade crossing where Route K091 (Water Street Bridge) crosses above the tracks of Luzerne County Redevelopment Authority, DOT Number Unknown, and the alteration of the at-grade crossing where the Riverfront Park Trail crosses the tracks of Luzerne County Redevelopment Authority, DOT Number 924 938R in the City of Pittston, Luzerne County as described below:

1. The name and address of Applicant are Commonwealth of Pennsylvania, Department of Transportation, Susan E. Hazelton, P.E., Assistant District Executive, Engineering District 4-0, 55 Keystone Industrial Park, Dunmore, PA 18512.

2. The name and address of attorney for the Applicant are Karen L. Cummings, Senior Counsel, Commonwealth of Pennsylvania, Department of Transportation, Office of Chief Counsel, PO Box 8212, Harrisburg, PA 17105-8212.

3. The Applicant is an agency of Commonwealth of Pennsylvania, organized and existing under the Administrative Code of 1929, 71 P.S. § 511, et seq. and generally 36 P.S. § 670 - 401 et seq., filing this Application on its behalf and on behalf of Luzerne County as evidenced by the resolution dated April 12, 2022 which is attached hereto and marked as Exhibit “A”.

4. The names and addresses of the persons, parties and entities concerned in, or affected by the proposed construction, to the best of the Applicant’s knowledge, are shown in the certificate of service. In addition to those served, the Applicant requests that the following also receive service of all documents in this matter:

Mark J. Chappell, P.E., Chief  
Utilities, Right-of-Way, and Grade Crossing  
Division  
Pennsylvania Department of Transportation  
PO Box 3362  
Harrisburg, PA 17105-3362  
[marchappel@pa.gov](mailto:marchappel@pa.gov)

Karen L. Cummings  
Counsel for Applicant  
Office of Chief of Counsel  
Pennsylvania Department of Transportation  
PO Box 8212  
[kcummings@pa.gov](mailto:kcummings@pa.gov)

5. The Applicant is seeking approval to replace the substructure and superstructure of the existing bridge carrying Water Street over the track of Luzerne County Redevelopment Authority at RR MP Unknown, and to modify the nearby at-grade pedestrian crossing at DOT No. 924 938 R to construct ADA ramps. The new structure will provide 23'-9" clearance over the railroad. To facilitate construction sequences, the pedestrian crossing will be closed during project construction. A Location Map and the Type, Size, and Location Plans are attached as Exhibits "B" and "C", respectively.

6. The Applicant is not aware of prior Public Utility Commission proceedings for these crossings.

7. The average daily traffic for the Water Street crossing is 10,200 vehicles with 7% trucks.

The average daily pedestrian traffic for the Riverfront Park crossing is unknown.

8. The estimated total cost for the project subject to the application and described above is \$50,000,000.00. It is anticipated that the funding for the project will be federal funds and state funds.

9. This project is necessary and proper for the safety and convenience of the public.

10. A conference of all parties of interest should be held to discuss the proposed alteration.

Wherefore, Applicant respectfully requests that the Public Utility Commission approve this application:

Respectfully Submitted:



---

Susan E. Hazelton, P.E.  
Assistant District Executive  
Engineering District 4-0  
Department of Transportation  
55 Keystone Industrial Park  
Dunmore, PA 18512  
Phone: (570) 963-4061  
Fax: (570) 963-4245  
email address: [shazelton@pa.gov](mailto:shazelton@pa.gov)

Dated: 3/3/2025

**RESOLUTION R-2022-76  
LUZERNE COUNTY COUNCIL**

*A Resolution of the Luzerne County Council Authorizing the County Manager  
to Execute a Multi-Bridge Projects Agreement with the Commonwealth of Pennsylvania*

WHEREAS, the General Assembly of the Commonwealth of Pennsylvania has appropriated funds for the removal or replacement of eligible bridges under the jurisdiction of local governments; and

WHEREAS, the eligible funds appropriated by the General Assembly reimburse a portion of the costs of bridge projects with the balance of the funding being provided by local governments; and

WHEREAS, Luzerne County seeks to replace a County owned bridge spanning the Susquehanna River between West Pittston and the City of Pittston, Pennsylvania; and

WHEREAS, as a condition of the Agreement, Luzerne County authorizes the Pennsylvania Department of Transportation to assume responsibility for the design and construction of the bridge rehabilitation project while retaining responsibility to maintain the bridge after construction; and

WHEREAS, Luzerne County Council desires to authorize the County Manager to execute the Multi-Bridge Projects Agreement with the Commonwealth of Pennsylvania, acting through the Department of Transportation.

NOW, THEREFORE, BE IT RESOLVED, the Luzerne County Council authorizes the County Manager to execute the Multi-Bridge Projects Agreement with the Commonwealth of Pennsylvania.

This Resolution shall become effective six days after adoption.

ADOPTED by Luzerne County Council at a public meeting held on the 12th day of April, 2022.

ROLL CALL VOTE (11-0)

YES: Bienias, Lescavage, Lombardo, McDermott, McGinley, Perry, Radle, Schnee, Thornton, SJ Urban and Wolovich

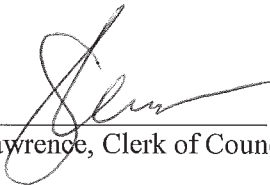
Attest:   
Sharon Lawrence, Clerk of Council







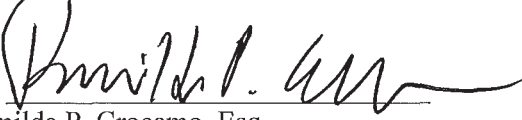

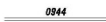
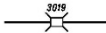
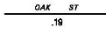

LUZERNE COUNTY COUNCIL

By:   
Kendra Radle, Chair

LUZERNE COUNTY MANAGER

By:   
Romilda P. Crocamo, Esq.  
Acting County Manager

**LEGEND**

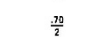
-  LIMITED ACCESS HIGHWAY
-  STATE ROUTE AND NUMBER
-  STATE MAINTAINED BRIDGE ON CITY STREET
-  CITY STREET NAME AND SEGMENT LENGTH IN MILES
-  TURNBACK CITY STREET
-  OTHER ROAD
-  COUNTY ROAD
-  RAILROAD
-  STATE BOUNDARY
-  COUNTY BOUNDARY
-  TOWNSHIP BOUNDARY
-  CITY OR BOROUGH BOUNDARY
-  MUNICIPAL BUILDING
-  SPLIT MILEAGE BETWEEN MUNICIPALITIES

POPULATION 7,739  
(2010 Census)

TOTAL MILES	
City Street System	25.91
State Highway System	6.98
<b>Total</b>	<b>32.89</b>

- ALLARDYCE AL
- ALLEY EIGHT AL
- ALLEY ELEVEN AL
- ALLEY FIVE AL
- ALLEY FOUR AL
- ALLEY NINE AL
- ALLEY ONE AL
- ALLEY SIX AL
- ALLEY TEN AL
- ALLEY THREE AL
- ALLEY TWO AL
- ANDERSON ST
- BALLET AL
- BENEDICT ST
- BILGERSKY LA
- BOCCI AL
- BOG IN ST
- BOVD AL
- BOVD ST
- BRANDENBURG LA
- BUTLER AL
- BUTLER ST
- CANTON DR
- CARROLL ST
- CENTER ST
- CHAPEL ST
- CHARLES ST
- CHEERY ST
- CHURCH ST
- CLEVELAND ST
- CLIFF ST
- COLUMBUS AV
- CORNELIA ST
- COON ST
- CURRAN ST
- CURRY ST
- CURTIS ST
- DEFE ST
- DEPER ST
- DEWITT ST
- DIMNEY ST
- DIVISION ST
- DOCK ST
- DUNWOOD ST
- EAST ST
- ELIZABETH ST
- ESTHER ST
- FEAR ST
- FORDY ST
- FRONT ST
- FROTHINGHAM ST
- FULTON ST
- GARFIELD ST
- GAZETTE PL
- GEORGE ST
- GLADING ST
- GRANDVIEW DR
- GRAVITY ST
- GREEN ST
- HALLWOOD AL
- HASTON ST
- HIGH ST
- HILLPARK AV
- HUNTER ST
- JAMES ST
- JENKINS CT
- JOHN ST
- JONSON ST
- KENNEDY ST
- LAGANNA ST
- LAMBERT ST
- LANDON ST
- LARUE LA
- LEONARD ST
- LESLIE LA
- LEIGH ROCK ST
- MAPLE LA
- MARRET ST
- MARTINS CT
- WILL HILL ST
- WILL ST
- WILTON ST
- WILTON ST
- WORGAN LA
- NARUS ST
- NEAR ST
- NO NAME RD
- ONE ST
- OCONNELL ST
- OLIVE PL
- OREGON PARK AL
- ORNSBY AL
- PANAMA ST
- PINE ST
- PRICE ST
- PROSPECT PL
- PROSPECT ST
- RADCLIFFE ST
- REAR TUNNEL ST
- RIVER ST
- ROBERTS ST
- RUTLEDGE ST
- SAND ST
- SAND ST AL
- SEABLE ST NEAR
- SENECA ST
- SPRING ST
- SPRING ST
- STARK ST
- STOUT ST
- SMALLOW ST
- TELDORIC ST
- THISTLE ST
- THOMAS ST
- TOMPKINS ST
- TOMPAT CT
- TUNNEL ST
- UNDERWOOD LA
- UNION ST
- VINE ST
- WASHINGTON TER
- WATER ST
- WEBSTER ST
- WEST ST
- WHARF ST
- WHARTON ST
- WILFORD ST
- WILSON LA
- WILSON ST
- WINTER ST
- WOOD ST

DOT No. 924 938 R  
Luzerne County Redevelopment Authority RR  
RR MP Unknown  
Riverfront Park Trail Crossing  
Pittston City  
Luzerne County

DOT No. Unknown  
Luzerne County Redevelopment Authority RR  
RR MP Unknown  
Route K091 Water Street Bridge  
Pittston City  
Luzerne County

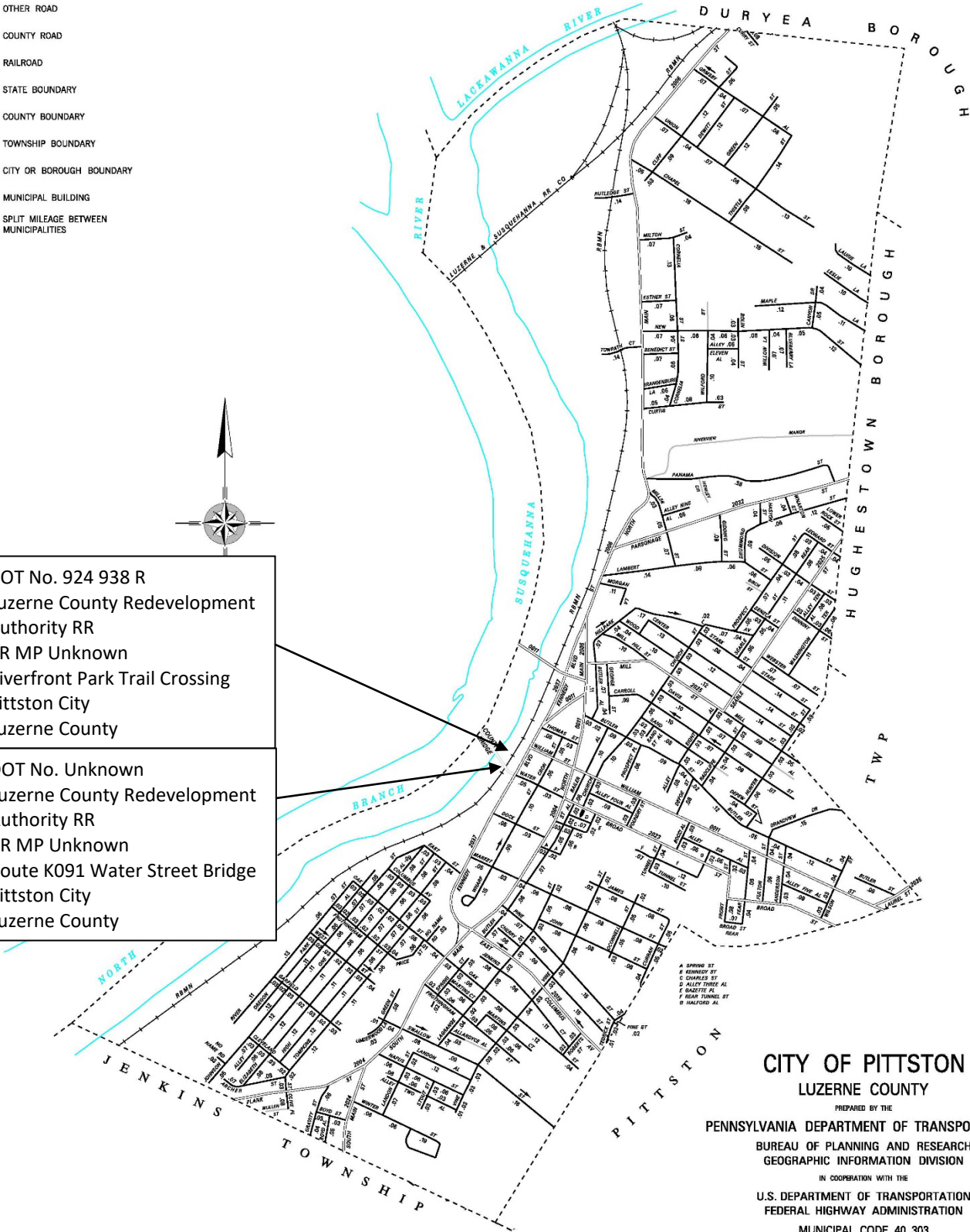

**CITY OF PITSTON**  
LUZERNE COUNTY

PREPARED BY THE  
PENNSYLVANIA DEPARTMENT OF TRANSPORTATION  
BUREAU OF PLANNING AND RESEARCH  
GEOGRAPHIC INFORMATION DIVISION  
IN COOPERATION WITH THE  
U.S. DEPARTMENT OF TRANSPORTATION  
FEDERAL HIGHWAY ADMINISTRATION  
MUNICIPAL CODE 40 303  
THIS MAP IS PUBLISHED AS A SUPPLEMENTAL  
DOCUMENTATION OF LIQUID FUELS TAX FUND MILEAGES  
REVISED PER FORM 990 DATED 5-16-19

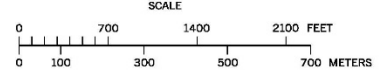

**Exhibit "B"**  
**Page 1 of 1**

COPIES OF THIS MAP ARE AVAILABLE AT NOMINAL COST  
PENNSYLVANIA DEPARTMENT OF TRANSPORTATION  
SALES STORE  
700 BUCK 3465  
HARRISBURG, PENNSYLVANIA 17105-3451  
TELEPHONE: (717)781-8746

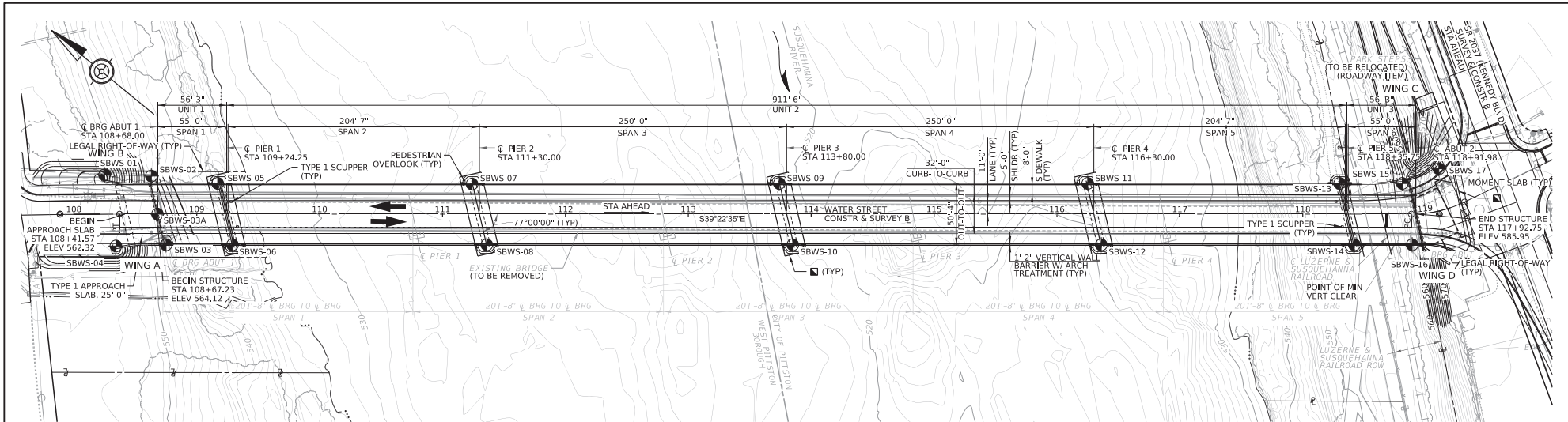

**WINGWALL NOTES**  
 WINGWALL A: CURVED U-WING, 39°-0"  
 WINGWALL B: CURVED U-WING, 39°-0"  
 WINGWALL C: FLARED @ 45°, 20'-0"  
 WINGWALL D: FLARED @ 45°, 20'-0"

**HORIZONTAL CURVE DATA**

**WATER STREET**

PI STA 107+88.76 Δ = 1°22'14" RT D = 1'25'57" T = 48.42' L = 96.84' R = 4000.00' E = 0.29'	PT STA 108+37.17 Δ = 25°40'57" LT D = 57°17'45" T = 22.80' L = 44.82' R = 100.00' E = 2.57'	PI STA 119+11.10 Δ = 25°40'57" LT D = 57°17'45" T = 22.80' L = 44.82' R = 100.00' E = 2.57'
--	---	---

**VERTICAL CURVE DATA**

**WATER STREET**

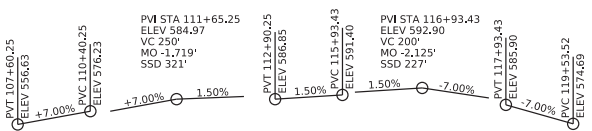

**CORE BORING LOCATIONS**

BORING #	STATION	OFFSET
SBWS-01	108+25	32' LT
SBWS-02	108+63	31' LT
SBWS-03	108+75	25' RT
SBWS-03A	108+68	0'
SBWS-04	108+34	26' RT
SBWS-05	109+17	25' LT
SBWS-06	109+29	25' RT
SBWS-07	111+24	25' LT
SBWS-08	111+36	25' RT
SBWS-09	113+74	25' LT
SBWS-10	113+85	25' RT
SBWS-11	116+25	25' LT
SBWS-12	116+36	25' RT
SBWS-13	118+30	25' LT
SBWS-14	118+42	25' RT
SBWS-15	118+81	25' LT
SBWS-16	118+89	25' RT
SBWS-17	119+23	33' LT

**EXISTING STRUCTURE DATA**  
 S-SPAN: SIMPLE PARKER THROUGH TRUSS BRIDGE  
 SPANS: SPAN 1 THRU 5 = 201'-8"  
 CLEARANCE: 19'-4" (RAILROAD)  
 SKEW: 78°15'00"  
 ROADWAY: 21'-0" CURB-TO-CURB  
 STRUCTURE NO. S-15138

**DESIGN DESIGNATION**  
**WATER STREET**

HIGHWAY CLASSIFICATION =  
 URBAN MINOR ARTERIAL  
 DESIGN SPEED = 25 MPH  
 ADT (2029) = 10,200  
 ADT (2049) = 10,700  
 DIRECTIONAL % = 58  
 TRUCK % = 7

NOTE: MEASURED FROM WATER STREET SURVEY AND CONSTR B

**LEGEND**

- 560 - EXISTING 1' CONTOURS
- 560 - EXISTING 10' CONTOURS
- 560 - PROPOSED 1' CONTOURS
- 560 - PROPOSED 10' CONTOURS
- ⊕ - PROPOSED BORING
- G - EXISTING GAS LINE (TO BE RELOCATED)
- S - EXISTING SEWER LINE
- EA - EXISTING AERIAL ELECTRIC (TO BE RELOCATED)
- TA - EXISTING AERIAL TELEPHONE
- x-x - EXISTING FENCE
- - - - EDGE OF WATERWAY
- ➔ - DIRECTION OF TRAVEL
- ☐ - APPROX LOCATION OF TEMPORARY EXCAVATION SUPPORT & PROTECTION SYSTEM

**HYDRAULIC DATA**

DRAINAGE AREA 9,900 SQ MILES  
 Q 25 FLOW 228,700 CFS  
 Q 25 ELEV 556.20  
 Q 25 VEL 8.3 FPS  
 Q 100 FLOW 294,900 CFS  
 Q 100 ELEV 562.93  
 Q 100 VEL 8.5 FPS

**HYDRAULIC DATA**

DRAINAGE AREA 9,900 SQ MILES  
 Q 25 FLOW 228,700 CFS  
 Q 25 ELEV 556.16  
 Q 25 VEL 8.3 FPS  
 Q 100 FLOW 294,900 CFS  
 Q 100 ELEV 562.89  
 Q 100 VEL 8.5 FPS

**INDEX OF DRAWINGS**

SHEET NO.	TITLE
1	TYPE, SIZE, AND LOCATION PLAN
2	TYPE, SIZE, AND LOCATION ELEVATION
3	TYPICAL SECTION - 1
4	TYPICAL SECTION - 2
5	FRAMING PLAN SPANS 1 & 6
6	FRAMING PLAN SPAN 2
7	FRAMING PLAN SPAN 3
8	FRAMING PLAN SPAN 4
9	FRAMING PLAN SPAN 5
10	TYPICAL PIER ELEVATION
11	ARCHITECTURAL DETAILS

Mark	Description	By	Chk'd.	Recm'd.	Date
REVISIONS					

COMMONWEALTH OF PENNSYLVANIA  
 DEPARTMENT OF TRANSPORTATION

LUZERNE COUNTY  
 SR 0011 SECTION 350  
 SEGMENT XXXX OFFSET XXXX  
 WATER STREET STA 113+80.00  
 OVER SUSQUEHANNA RIVER & LUZERNE CO RAIL AUTH  
 SIX SPAN COMPOSITE STEEL MULTI GIRDER BRIDGE REPLACEMENT  
 TYPE, SIZE, AND LOCATION PLAN

MCCORMICK TAYLOR, INC.  
 5 CAPITAL DRIVE  
 Suite 400  
 Harrisburg, PA 17110  
 phone: 717-540-6040



Digitally signed by  
 Brandon Newpher  
 Date: 2024.04.10  
 09:21:13-04'00'

RECOMMENDED \_\_\_\_\_ SHEET 1 OF 11  
 \_\_\_\_\_  
 CHIEF BRIDGE ENGINEER

L-523

By: bjn  
4/10/2024  
5 FILES

DES. SMC    CHK. GRB    DWG. TAD    CHK. BJB

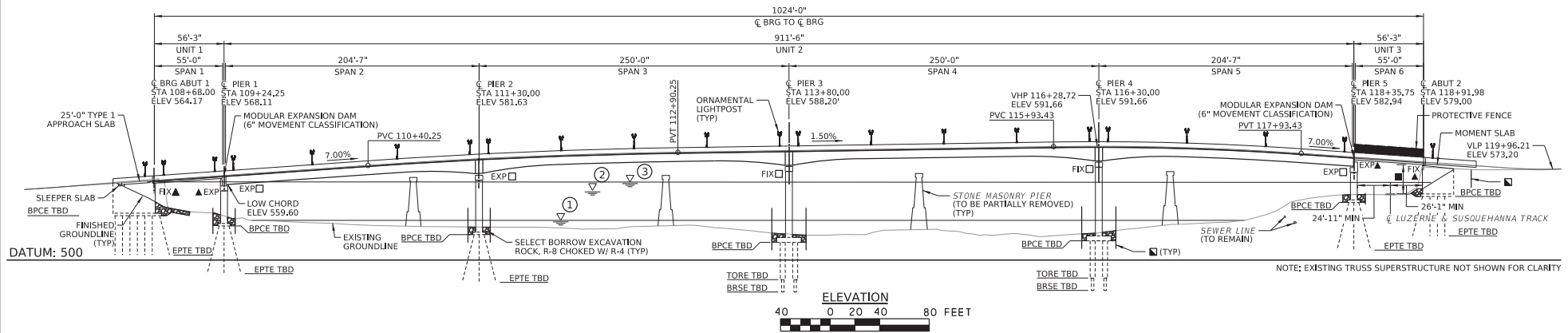

**DESIGN SPECIFICATIONS**

1. AASHTO LRFD BRIDGE DESIGN SPECIFICATIONS (2017) AND AS SUPPLEMENTED BY DESIGN MANUAL, PART 4, DECEMBER 2019.
2. LIVE LOAD DISTRIBUTION TO BEAMS IS BASED UPON DM4 DISTRIBUTION FACTOR METHOD.
3. DESIGN IS IN ACCORDANCE WITH THE LOAD AND RESISTANCE FACTOR DESIGN (LRFD) METHOD.

**DESIGN LIVE LOADS**

1. PHL-93, P-82, AND P2016-13.
2. FATIGUE DESIGN IS BASED ON THE FOLLOWING:  
ADTT 435 (2049)

**DEAD LOADS**

1. INCLUDES SURFACE AREA DENSITY OF 0.030 KSF FOR FUTURE WEARING SURFACE ON THE DECK SLAB. POLYESTER POLYMER CONCRETE (PPC) OVERLAY INCLUDED IN FUTURE WEARING SURFACE LOADING.
2. INCLUDES A SURFACE AREA DENSITY OF 0.015 KSF FOR PERMANENT METAL DECK FORMS WHICH TAKES INTO ACCOUNT THE WEIGHT OF THE FORM, PLUS THE WEIGHT OF THE CONCRETE IN THE VALLEYS OF THE FORMS.
3. INCLUDES A WEIGHT OF 0.050 KLF FOR THE WEIGHT OF THE PROTECTIVE FENCE IN SPAN 6.

**GENERAL NOTES**

1. PROVIDE MATERIALS AND PERFORM WORK IN ACCORDANCE WITH PENNSYLVANIA DEPARTMENT OF TRANSPORTATION SPECIFICATIONS, PUBLICATION 408 (2020), AASHTO/AWS D1.5M/D1.5:2015 BRIDGE WELDING CODE (2015) AND CONTRACT SPECIAL PROVISIONS, USE AASHTO/AWS D1.1/D1.1M:2015 FOR WELDING NOT COVERED IN AASHTO/AWS D1.5M/D1.5:2015.
2. EXISTING STRUCTURE IS TO BE REMOVED 3'-0" MINIMUM BELOW FINISHED GROUNDLINE OR AS NECESSARY TO AVOID THE PROPOSED CONSTRUCTION.
3. ALL STRUCTURAL STEEL WILL CONFIRM TO AASHTO M270 GRADE 50 (ASTM A709-50).
4. PAINT IN ACCORDANCE WITH PUBLICATION 408, SECTION 1060, FINISH COAT COLOR TO BE DETERMINED IN FINAL DESIGN.

EXISTING STRUCTURE GEOMETRY	
SPAN	NORMAL CLEAR SPAN
SPAN 1	192.96 FT
SPAN 2	193.48 FT
SPAN 3	193.48 FT
SPAN 4	193.48 FT
SPAN 5	193.88 FT

PROPOSED STRUCTURE GEOMETRY	
SPAN	NORMAL CLEAR SPAN
SPAN 1	51.06 FT
SPAN 2	194.48 FT
SPAN 3	237.59 FT
SPAN 4	237.59 FT
SPAN 5	194.48 FT
SPAN 6	51.06 FT

**LEGEND**

- BPCE BOTTOM OF PILE CAP ELEVATION
- BRSE BOTTOM OF ROCK SOCKET ELEVATION
- EPTE ESTIMATED PILE TIP ELEVATION
- TBD TO BE DETERMINED
- TORE TOP OF ROCK ELEVATION
- POINT OF MINIMUM VERTICAL CLEARANCE (LCRR) 23'-6" REQ'D, 23'-8" PROVIDED
- ▲ LAMINATED ELASTOMERIC BEARING PADS
- HIGH LOAD MULTI-ROTATIONAL BEARINGS
- APPROX LOCATION OF TEMPORARY EXCAVATION SUPPORT & PROTECTION SYSTEM
- ① NORMAL WATER ELEV = 532.00
- ② Q<sub>25</sub> ELEV = 556.16
- ③ Q<sub>100</sub> ELEV = 562.89

Mark	Description	By	Chk'd.	Recm'd.	Date
REVISIONS					

OWNED AND MAINTAINED BY LUZERNE COUNTY  
BMS STR ID: 40-7303-2305-0005 MPMS/ECMS PROJ: S3931 BRKEY: 70354

**COMMONWEALTH OF PENNSYLVANIA**  
DEPARTMENT OF TRANSPORTATION

**LUZERNE COUNTY**  
SR 0011 SECTION 350  
SEGMENT XXXX OFFSET XXXX  
WATER STREET STA 113+80.00  
OVER SUSQUEHANNA RIVER & LUZERNE CO RAIL AUTH  
SIX SPAN COMPOSITE STEEL MULTI GIRDER BRIDGE REPLACEMENT  
TYPE, SIZE, AND LOCATION ELEVATION



RECOMMENDED \_\_\_\_\_ SHEET 2 OF 11

L-523

SUSERS  
SDATES  
SFILES

DES. SMC CHK. GRB DWG. TAD CHK. BJN

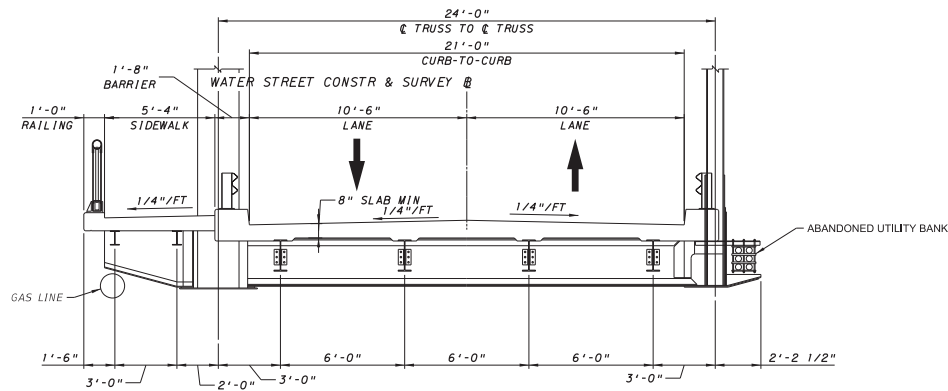

TYPICAL EXISTING SECTION  
 3 0 1 3 6 FEET

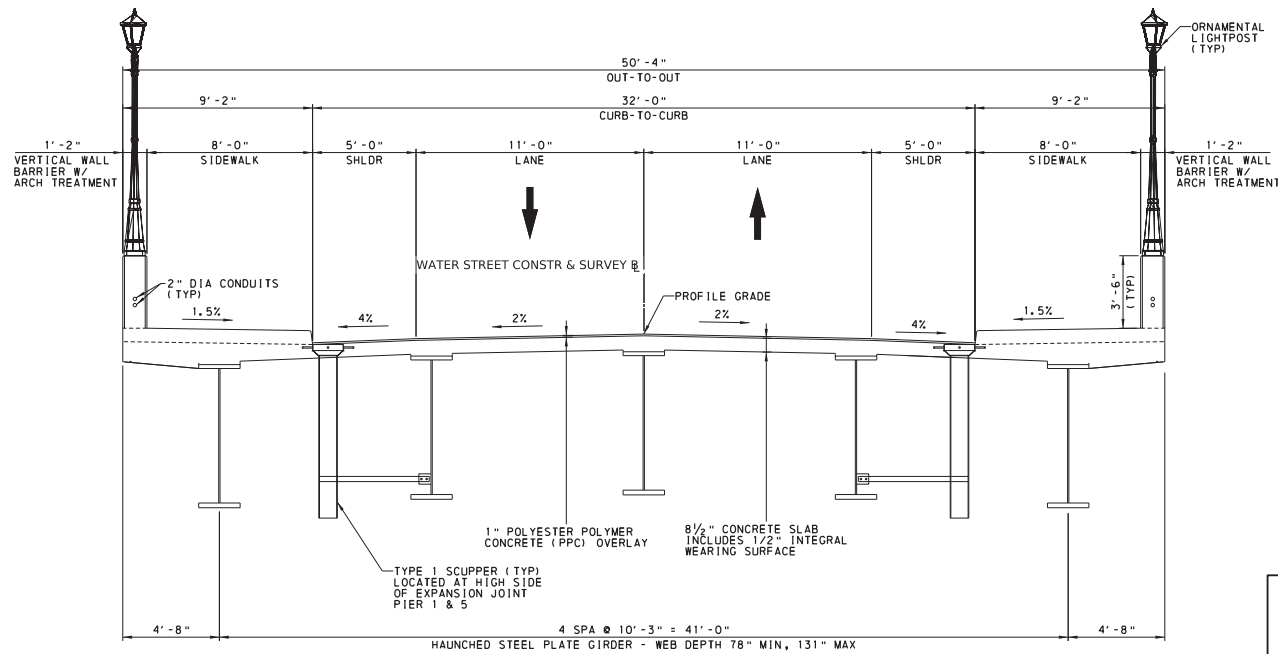

TYPICAL PROPOSED SECTION  
 (SPANS 2 THRU 5)  
 3 0 1 3 6 FEET

Mark	Description	By	Chk'd.	Recm'd.	Date
REVISIONS					

OWNED AND MAINTAINED BY LUZERNE COUNTY  
 BMS STR ID: 40-7303-2305-0005 MPMS/ECMS PROJ: 93931 BRKEY: 70354

COMMONWEALTH OF PENNSYLVANIA  
 DEPARTMENT OF TRANSPORTATION

LUZERNE COUNTY  
 SR 0011 SECTION 350

SEGMENT XXXX OFFSET XXXX  
 WATER STREET STA 113+80.00  
 OVER SUSQUEHANNA RIVER & LUZERNE CO RAIL AUTH  
 SIX SPAN COMPOSITE STEEL MULTI GIRDER BRIDGE REPLACEMENT

TYPICAL SECTION -1



RECOMMENDED \_\_\_\_\_

SHEET 3 OF 11

L-523

SUSERS  
SDATES  
SFILES

DES. SMC    CHK. GRB    DWG. TAD    CHK. BJN

SUSPENS  
SPACES  
FILES

DES. SMC    CHK. GRB    DWG. TAD    CHK. BJN

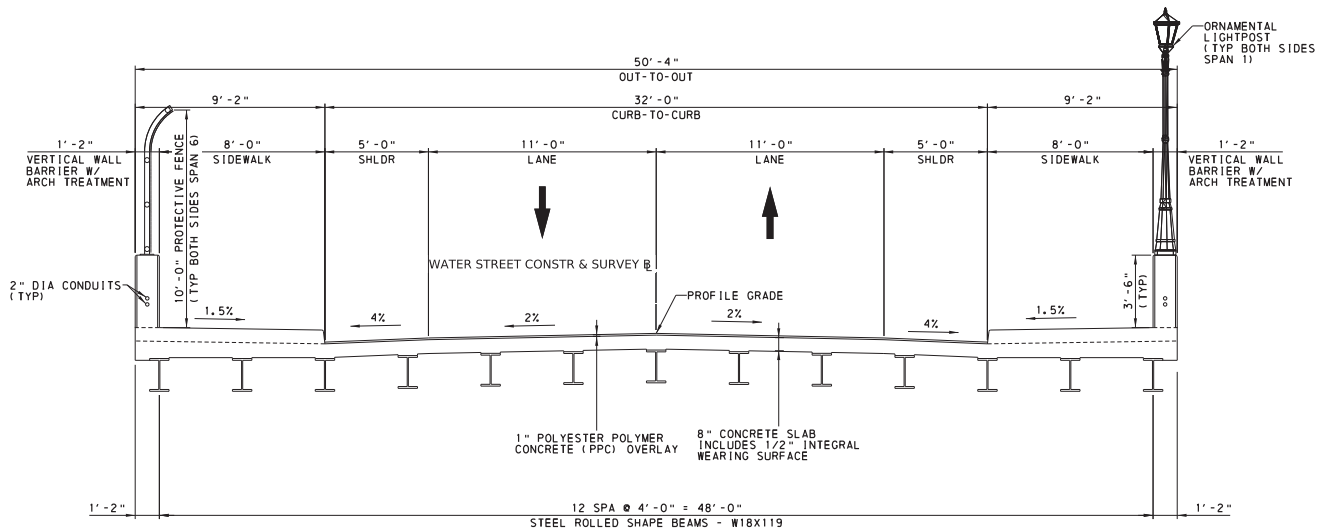

**TYPICAL PROPOSED SECTION**  
(SPANS 1 AND 6)



Mark	Description	By	Chk'd.	Recm'd.	Date
REVISIONS					

OWNED AND MAINTAINED BY LUZERNE COUNTY  
BMS STR ID: 40-7303-2305-0005 MPMS/ECMS PROJ: 93931 BRKEY: 70354

**COMMONWEALTH OF PENNSYLVANIA**  
DEPARTMENT OF TRANSPORTATION

**LUZERNE COUNTY**  
SR 0011 SECTION 350

SEGMENT XXXX OFFSET XXXX  
WATER STREET STA 113+80.00  
OVER SUSQUEHANNA RIVER & LUZERNE CO RAIL AUTH  
SIX SPAN COMPOSITE STEEL MULTI GIRDER BRIDGE REPLACEMENT

TYPICAL SECTION -2



RECOMMENDED \_\_\_\_\_

SHEET 4 OF 11

L-523

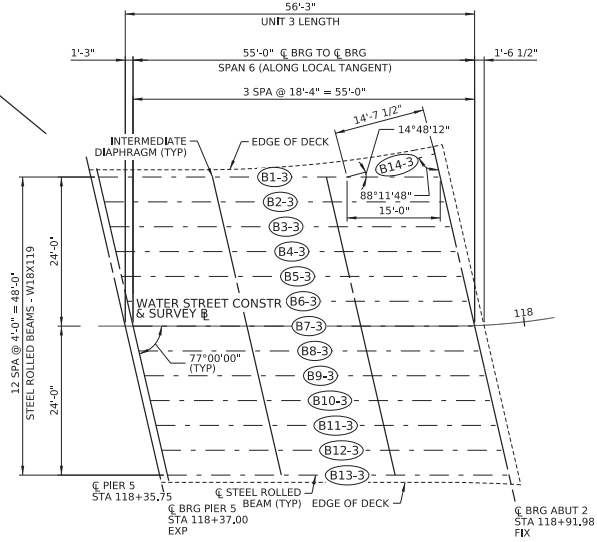
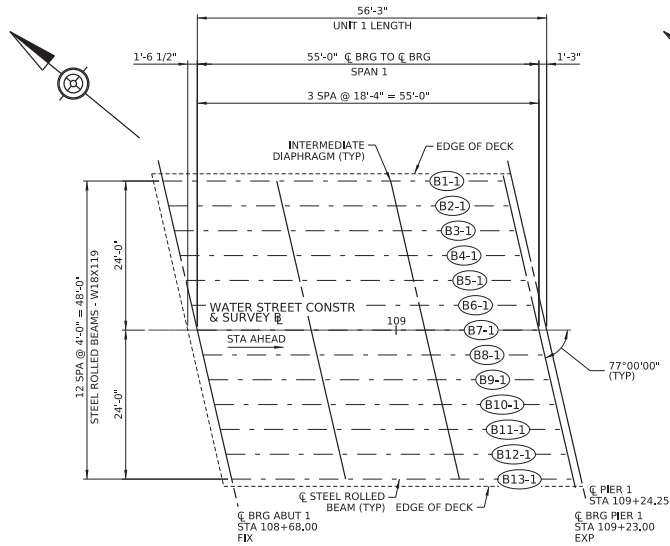

**LEGEND**

(G1-1) GIRDER NUMBER - UNIT NUMBER

**NOTES:**

- CROSS FRAME MEMBER SIZES ARE PRELIMINARY AND WILL BE ANALYZED DURING FINAL DESIGN.

**FRAMING PLAN - SPAN 1**  
(UNIT 1)

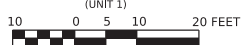

**FRAMING PLAN - SPAN 6**  
(UNIT 3)

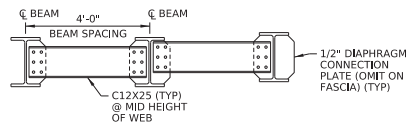
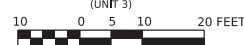

**TYPICAL INTERMEDIATE DIAPHRAGM**  
(UNIT 1 & 3)



Mark	Description	By	Chk'd.	Recm'd.	Date
REVISIONS					

OWNED AND MAINTAINED BY LUZERNE COUNTY  
BMS STR ID: 40-7303-2305-0005 MPMS/ECMS PROJ: 93931 BRKEY: 70354

**COMMONWEALTH OF PENNSYLVANIA**  
**DEPARTMENT OF TRANSPORTATION**

**LUZERNE COUNTY**  
**SR 0011 SECTION 350**

SEGMENT XXXX OFFSET XXXX  
WATER STREET STA 113+80.00  
OVER SUSQUEHANNA RIVER & LUZERNE CO RAIL AUTH  
SIX SPAN COMPOSITE STEEL MULTI GIRDER BRIDGE REPLACEMENT  
**FRAMING PLAN SPANS 1 & 6**



RECOMMENDED \_\_\_\_\_

SHEET 5 OF 11

L-523

SUSQUEHANNA RIVER  
STATES  
FILES

DES. SMC    CHK. GRB    DWG. TAD    CHK. BJN

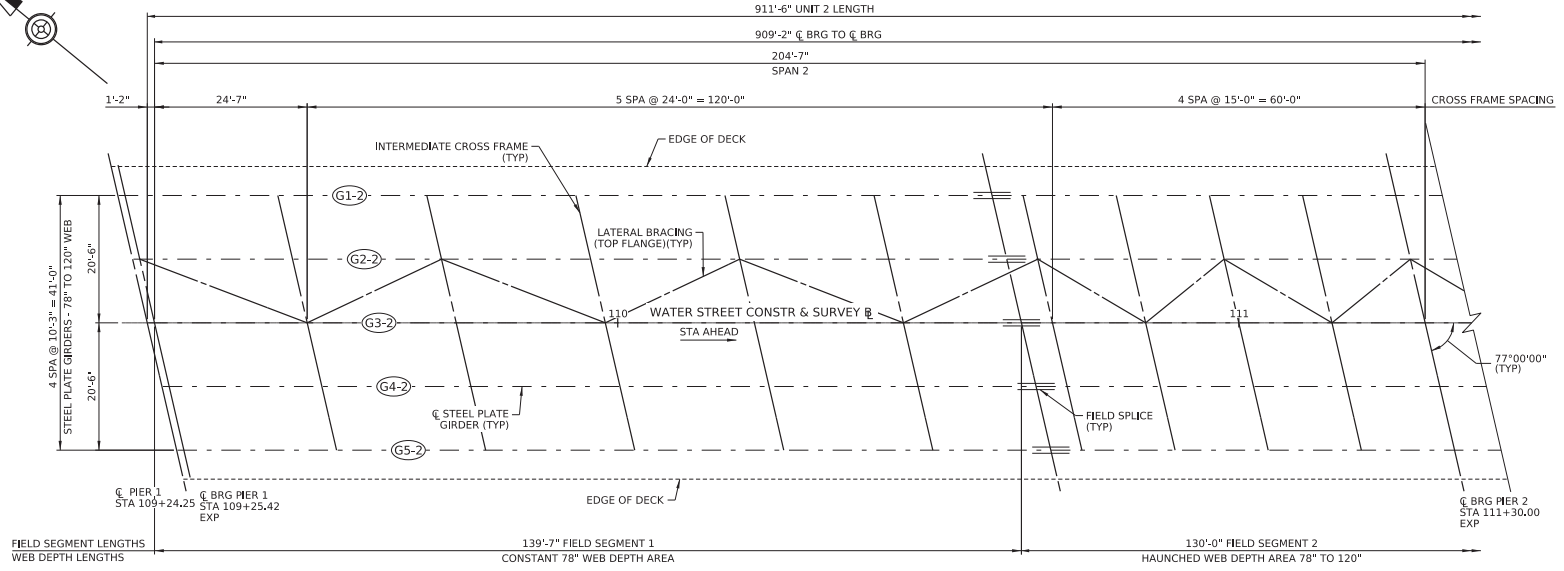
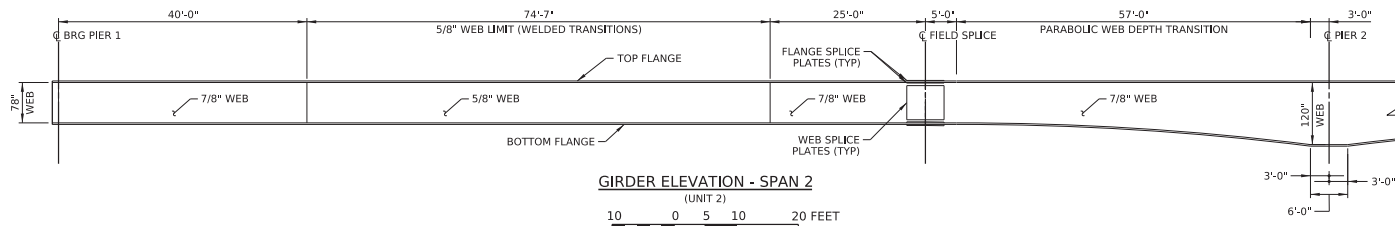

**LEGEND**  
 (G1-1) GIRDER NUMBER - UNIT NUMBER

**NOTES:**  
 1. CROSS FRAME MEMBER SIZES ARE PRELIMINARY AND WILL BE ANALYZED DURING FINAL DESIGN.

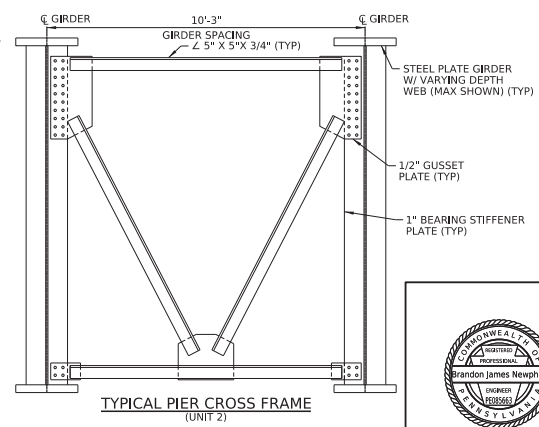
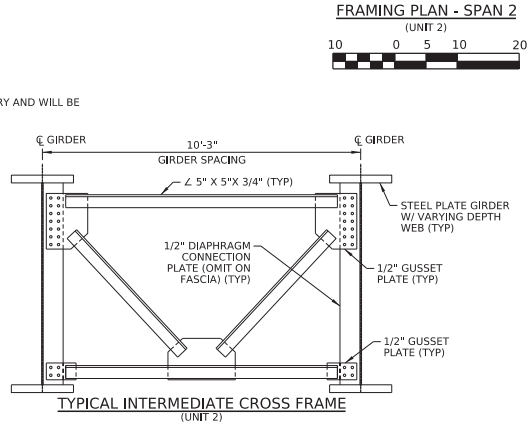

Mark	Description	By	Chk'd.	Recm'd.	Date
REVISIONS					

OWNED AND MAINTAINED BY LUZERNE COUNTY  
 BMS STR ID: 40-7303-2305-0005 MPMS/ECMS PROJ: 93931 BRKEY: 70354  
**COMMONWEALTH OF PENNSYLVANIA**  
 DEPARTMENT OF TRANSPORTATION  
 LUZERNE COUNTY  
 SR 0011 SECTION 350  
 SEGMENT XXXX OFFSET XXXX  
 WATER STREET STA 113+80.00  
 OVER SUSQUEHANNA RIVER & LUZERNE CO RAIL AUTH  
 SIX SPAN COMPOSITE STEEL MULTI GIRDER BRIDGE REPLACEMENT  
 FRAMING PLAN SPAN 2



RECOMMENDED \_\_\_\_\_ SHEET 6 OF 11

L-523

DES.	SMC	CHK.	GRB	DWG.	TAD	CHK.	BJN
------	-----	------	-----	------	-----	------	-----

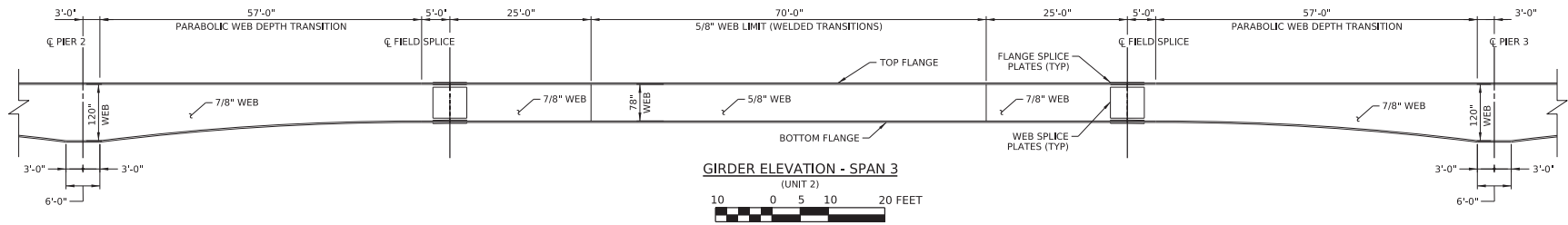

**GIRDER ELEVATION - SPAN 3**  
(UNIT 2)  
10 0 5 10 20 FEET

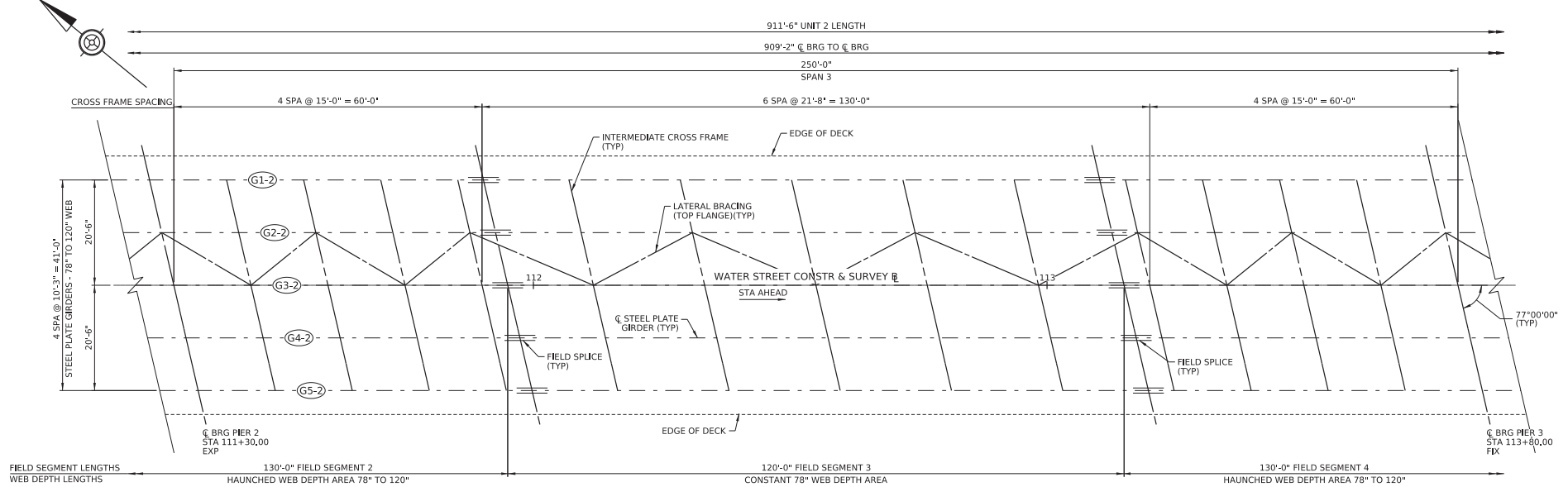

**FRAMING PLAN - SPAN 3**  
(UNIT 2)  
10 0 5 10 20 FEET

**LEGEND**

G1-1 GIRDER NUMBER - UNIT NUMBER

**NOTES:**

- CROSS FRAME MEMBER SIZES ARE PRELIMINARY AND WILL BE ANALYZED DURING FINAL DESIGN.

Mark	Description	By	Chk'd.	Recm'd.	Date
REVISIONS					

OWNED AND MAINTAINED BY LUZERNE COUNTY  
BMS STR ID: 40-7303-2305-0005 MPMS/ECMS PROJ: 93931 BRKEY: 70354

**COMMONWEALTH OF PENNSYLVANIA**  
DEPARTMENT OF TRANSPORTATION

**LUZERNE COUNTY**  
SR 0011 SECTION 350

SEGMENT XXXX OFFSET XXXX  
WATER STREET STA 113+80.00  
OVER SUSQUEHANNA RIVER & LUZERNE CO RAIL AUTH  
SIX SPAN COMPOSITE STEEL MULTI GIRDER BRIDGE REPLACEMENT  
FRAMING PLAN SPAN 3



RECOMMENDED _____	SHEET <u>7</u> OF <u>11</u>
	L-523

SUSERS  
DATES  
FILES

DES.	SMC	CHK.	GRB	DWG.	TAD	CHK.	BJN
------	-----	------	-----	------	-----	------	-----

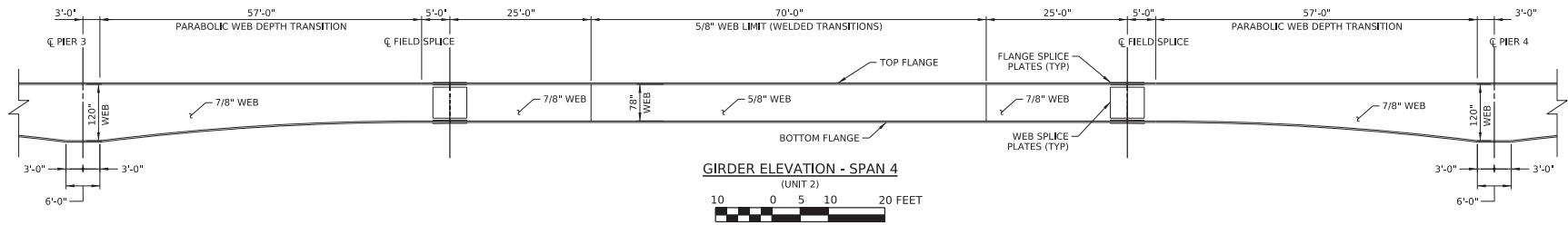

GIRDER ELEVATION - SPAN 4  
(UNIT 2)

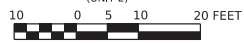

911'-6" UNIT 2 LENGTH

909'-2" C BRG TO C BRG

250'-0" SPAN 3

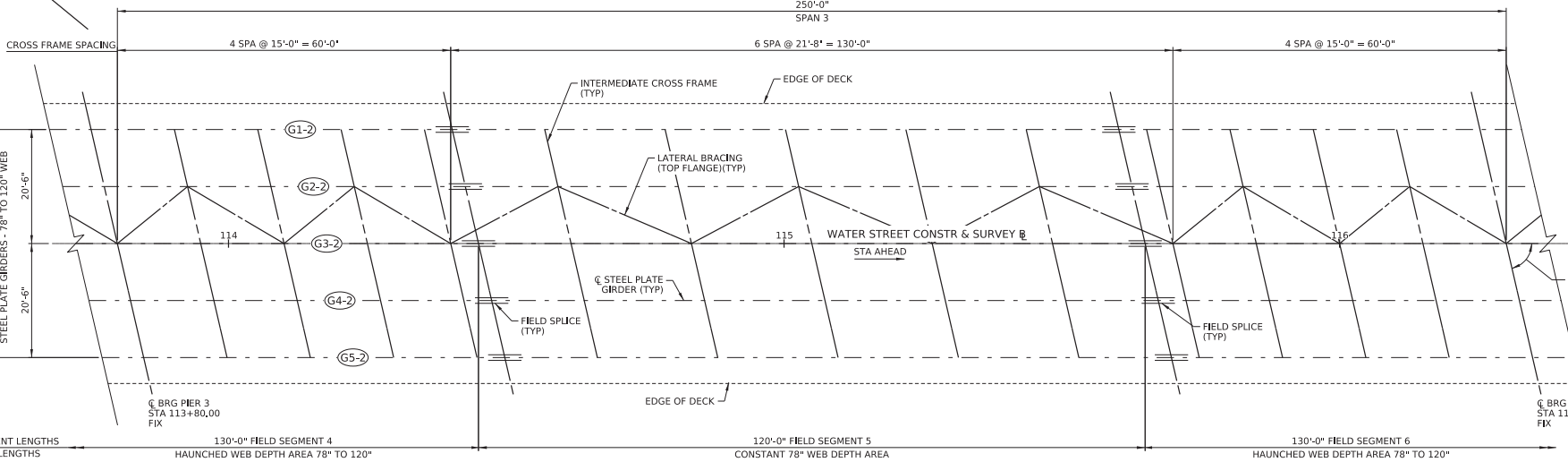

FRAMING PLAN - SPAN 4  
(UNIT 2)

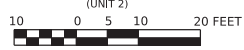

**LEGEND**

G1-1 GIRDER NUMBER - UNIT NUMBER

**NOTES:**

- CROSS FRAME MEMBER SIZES ARE PRELIMINARY AND WILL BE ANALYZED DURING FINAL DESIGN.

Mark	Description	By	Chk'd.	Recm'd.	Date
REVISIONS					

OWNED AND MAINTAINED BY LUZERNE COUNTY  
BMS STR ID: 40-7303-2305-0005 MPMS/ECMS PROJ: 93931 BRKEY: 70354

**COMMONWEALTH OF PENNSYLVANIA**  
DEPARTMENT OF TRANSPORTATION

LUZERNE COUNTY  
SR 0011 SECTION 350

SEGMENT XXXX OFFSET XXXX  
WATER STREET STA 113+80.00  
OVER SUSQUEHANNA RIVER & LUZERNE CO RAIL AUTH  
SIX SPAN COMPOSITE STEEL MULTI GIRDER BRIDGE REPLACEMENT  
FRAMING PLAN SPAN 4



RECOMMENDED \_\_\_\_\_ SHEET 8 OF 11

L-523

SUSERS  
DATES  
FILES

DES.	SMC	CHK.	GRB	DWG.	TAD	CHK.	BJN
------	-----	------	-----	------	-----	------	-----

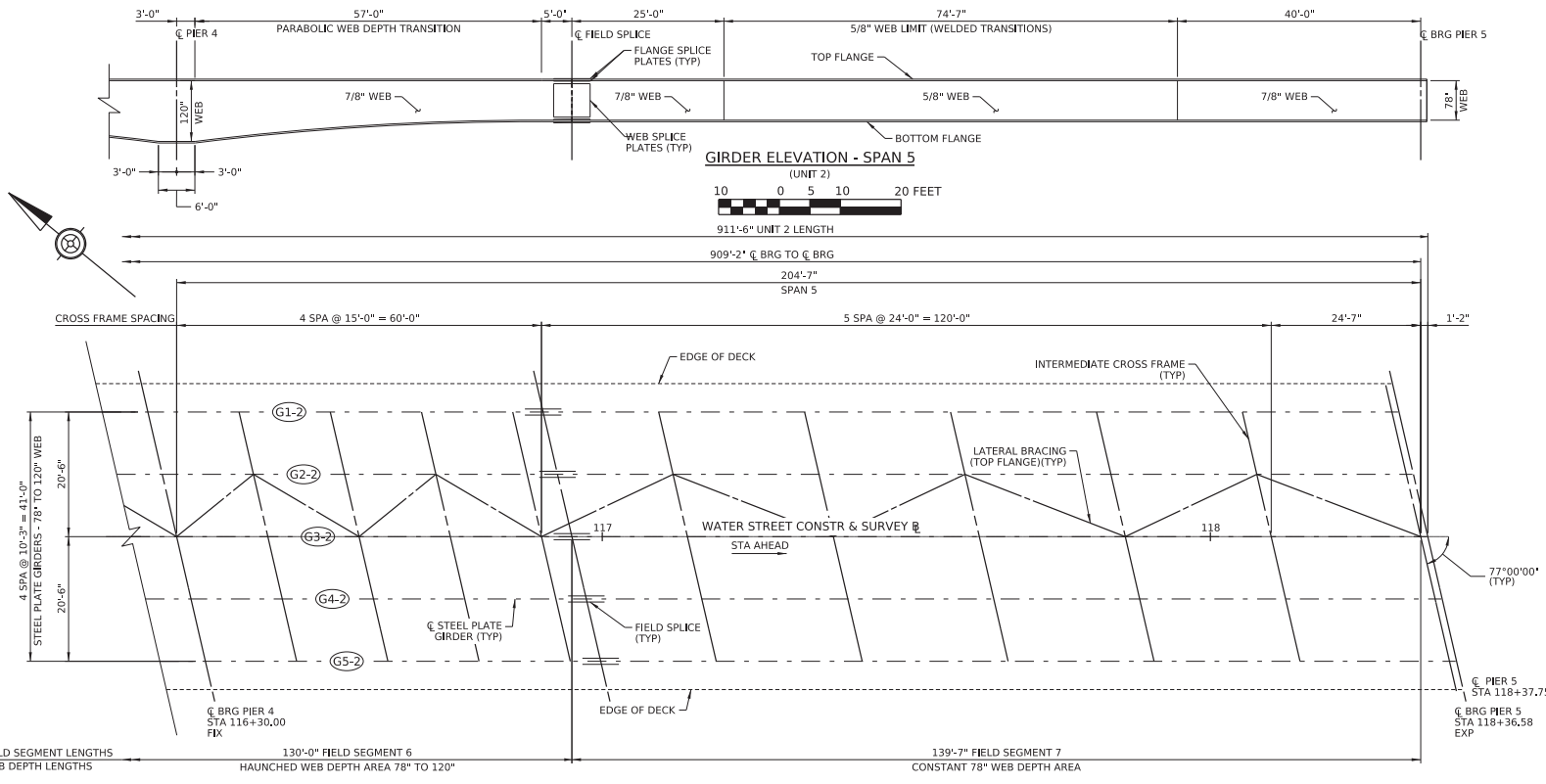

GIRDER ELEVATION - SPAN 5  
(UNIT 2)

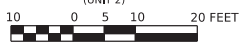

FRAMING PLAN - SPAN 5  
(UNIT 2)

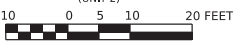

**LEGEND**

(G1-1) GIRDER NUMBER - UNIT NUMBER

**NOTES:**

- CROSS FRAME MEMBER SIZES ARE PRELIMINARY AND WILL BE ANALYZED DURING FINAL DESIGN.

Mark	Description	By	Chk'd.	Recm'd.	Date
REVISIONS					

OWNED AND MAINTAINED BY LUZERNE COUNTY  
BMS STR ID: 40-7303-2305-0005 MPMS/ECMS PROJ: 93931 BRKEY: 70354

COMMONWEALTH OF PENNSYLVANIA  
DEPARTMENT OF TRANSPORTATION

LUZERNE COUNTY  
SR 0011 SECTION 350

SEGMENT XXXX OFFSET XXXX  
WATER STREET STA 113+80.00  
OVER SUSQUEHANNA RIVER & LUZERNE CO RAIL AUTH  
SIX SPAN COMPOSITE STEEL MULTI GIRDER BRIDGE REPLACEMENT  
FRAMING PLAN SPAN 5



RECOMMENDED \_\_\_\_\_ SHEET 9 OF 11

L-523

SUSERS  
DATES  
FILES

DES.	SMC	CHK.	GRB	DWG.	TAD	CHK.	BJN
------	-----	------	-----	------	-----	------	-----

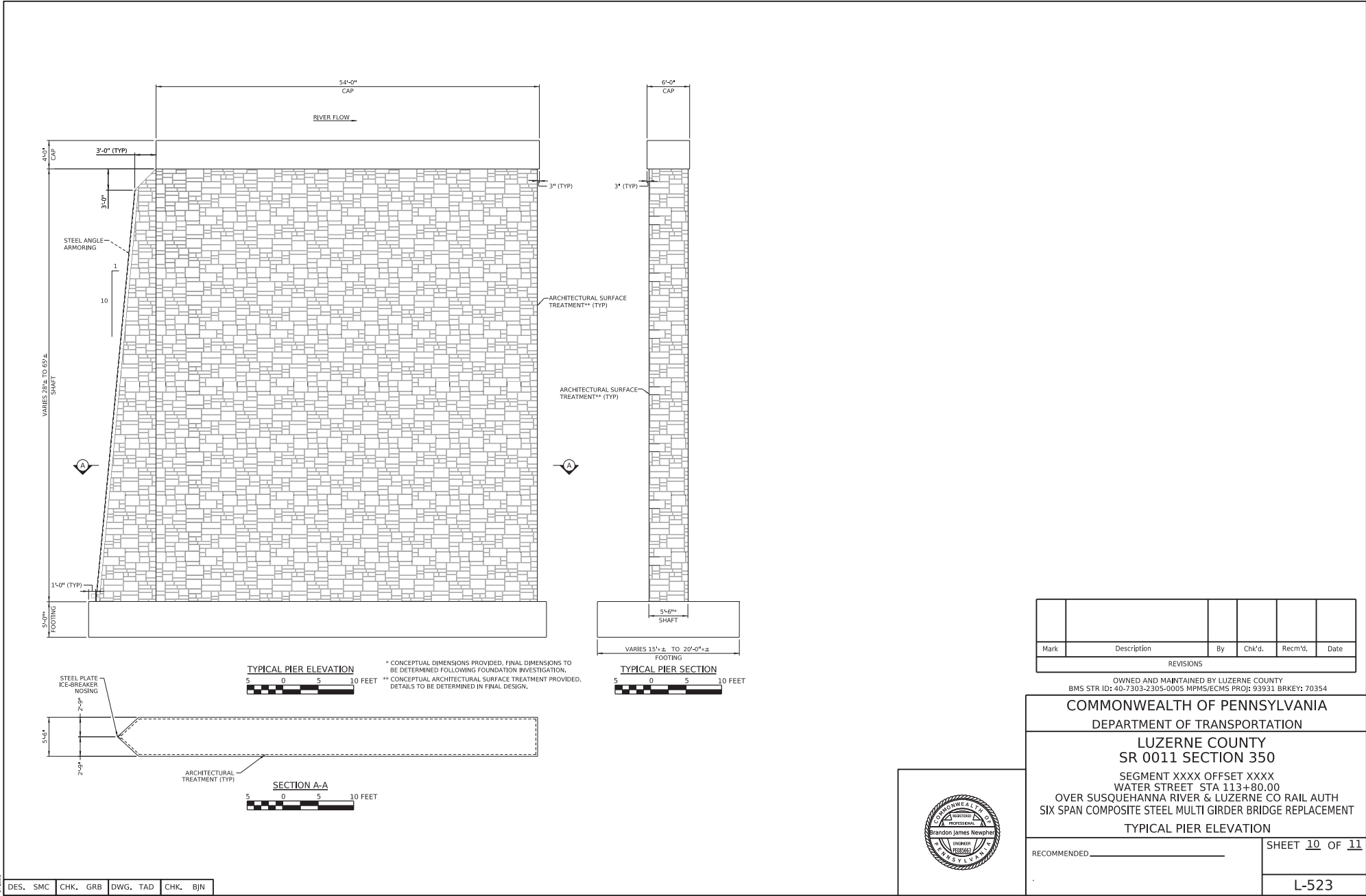

SUSERS  
 SDATES  
 SFILES

DES. SMC    CHK. GRB    DWG. TAD    CHK. BJN

**TYPICAL PIER ELEVATION**  
 5 0 5 10 FEET

\* CONCEPTUAL DIMENSIONS PROVIDED. FINAL DIMENSIONS TO BE DETERMINED FOLLOWING FOUNDATION INVESTIGATION.  
 \*\* CONCEPTUAL ARCHITECTURAL SURFACE TREATMENT PROVIDED. DETAILS TO BE DETERMINED IN FINAL DESIGN.

**TYPICAL PIER SECTION**  
 5 0 5 10 FEET

**SECTION A-A**  
 5 0 5 10 FEET

Mark	Description	By	Chk'd.	Recm'd.	Date
REVISIONS					

OWNED AND MAINTAINED BY LUZERNE COUNTY  
 BMS STR ID: 40-7303-2305-0005 MPMS/ECMS PROJ: 93931 BRKEY: 70354

**COMMONWEALTH OF PENNSYLVANIA**  
 DEPARTMENT OF TRANSPORTATION

**LUZERNE COUNTY**  
 SR 0011 SECTION 350

SEGMENT XXXX OFFSET XXXX  
 WATER STREET STA 113+80.00  
 OVER SUSQUEHANNA RIVER & LUZERNE CO RAIL AUTH  
 SIX SPAN COMPOSITE STEEL MULTI GIRDER BRIDGE REPLACEMENT  
 TYPICAL PIER ELEVATION



RECOMMENDED \_\_\_\_\_ SHEET 10 OF 11

L-523

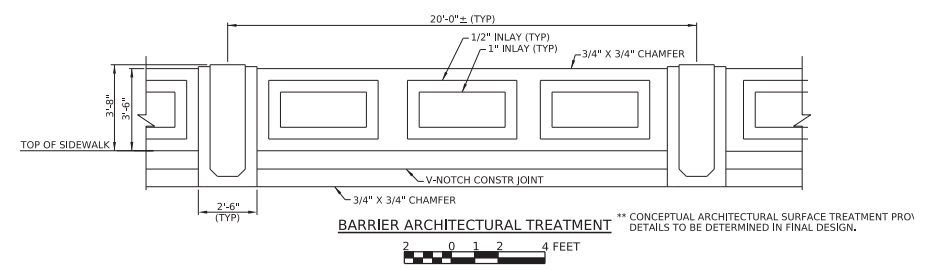
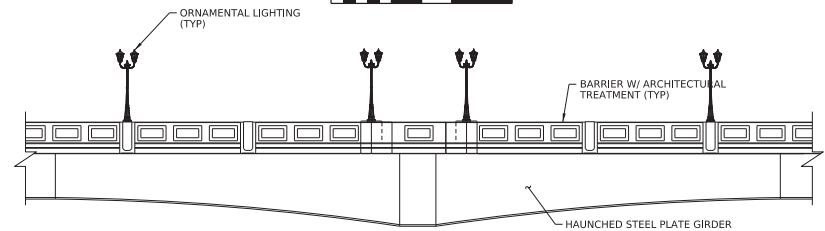
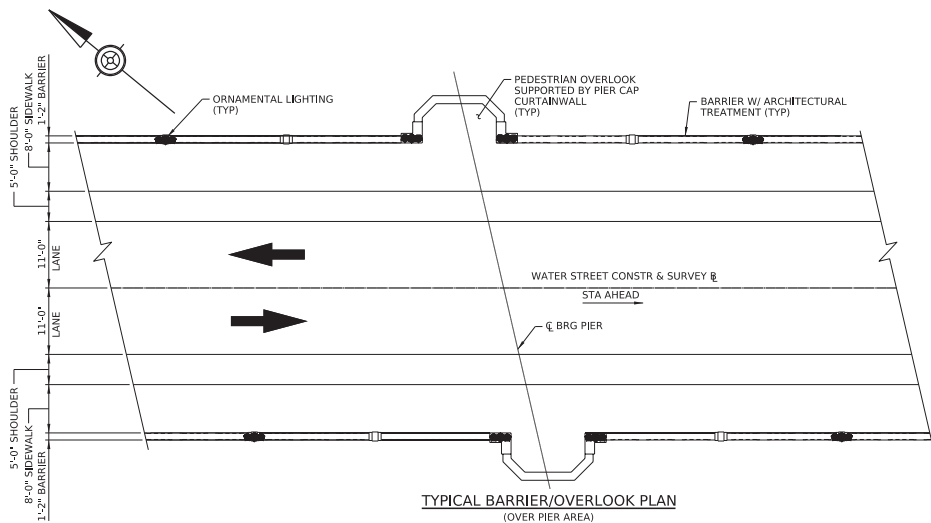

Mark	Description	By	Chk'd.	Recm'd.	Date
REVISIONS					

OWNED AND MAINTAINED BY LUZERNE COUNTY  
BMS STR ID: 40-7303-2305-0005 MPMS/ECMS PROJ: 93931 BRKEY: 70354

**COMMONWEALTH OF PENNSYLVANIA**  
DEPARTMENT OF TRANSPORTATION

LUZERNE COUNTY  
SR 0011 SECTION 350

SEGMENT XXXX OFFSET XXXX  
WATER STREET STA 113+80.00  
OVER SUSQUEHANNA RIVER & LUZERNE CO RAIL AUTH  
SIX SPAN COMPOSITE STEEL MULTI GIRDER BRIDGE REPLACEMENT  
ARCHITECTURAL DETAILS



RECOMMENDED \_\_\_\_\_ SHEET **11** OF **11**

L-523

SUSERS  
DATES  
FILES

DES. SMC	CHK. GRB	DWG. TAD	CHK. BJN
----------	----------	----------	----------

**BEFORE THE  
PENNSYLVANIA PUBLIC UTILITY COMMISSION**

Application of the Department of Transportation of the Commonwealth of Pennsylvania for approval to replace the bridge where Water Street Bridge (K091) crosses above the track of Luzerne County Redevelopment Authority, DOT Number Unknown, and to alter the at-grade crossing where the Riverfront Park Trail crosses the tracks of Luzerne County Redevelopment Authority, DOT Number 924 938 R in the City of Pittston, Luzerne County and the allocation of costs incident thereto.

Application  
Docket No. \_\_\_\_\_

**Electronically Filed**

VERIFICATION

I, John E. Pfeiffer, District 4-0 Grade Crossing Engineer, hereby state that the facts above set forth are true and correct to the best of my knowledge, information, and belief and that I expect to be able to prove the same at a hearing held in this matter. I understand that the statements herein are made subject to the penalties of 18 Pa.C.S. §4904 (relating to unsworn falsification to authorities).

Date: March 4, 2025

  
\_\_\_\_\_  
John E. Pfeiffer  
District 4-0  
Grade Crossing Engineer

**BEFORE THE  
PENNSYLVANIA PUBLIC UTILITY COMMISSION**

Application of the Department of Transportation of the Commonwealth of Pennsylvania for approval to replace the bridge where Water Street Bridge (K091) crosses above the track of Luzerne County Redevelopment Authority, DOT Number Unknown, and to alter the at-grade crossing where the Riverfront Park Trail crosses the tracks of Luzerne County Redevelopment Authority, DOT Number 924 938 R in the City of Pittston, Luzerne County and the allocation of costs incident thereto.

Application  
Docket No. \_\_\_\_\_

**Electronically Filed**

**CERTIFICATE OF SERVICE**

I hereby certify that I have this day served a true copy of the foregoing document upon the participants listed below, in accordance with the requirements of 52 Pa. Code § 1.54, by electronic mail:

Margaret Thomas, LCRA  
Redevelopment Authority of Luzerne County  
16 Luzerne Avenue – Suite #210  
West Pittston, PA 18643  
[margie.thomas@lcredauth.org](mailto:margie.thomas@lcredauth.org)

Ronald Pawlowski  
Comcast  
1 Comcast Way  
Duryea, PA 18642  
[Ronald\\_pawlowski@cable.comcast.com](mailto:Ronald_pawlowski@cable.comcast.com)

John Lombardo, Chairperson  
Luzerne County Commissioners  
Luzerne County Courthouse  
200 North River St.  
Wilkes-Barre PA 18711  
[john.lombardo@luzernecounty.org](mailto:john.lombardo@luzernecounty.org)

David Hines  
City of Pittston  
35 Broad St.  
Pittston, PA 18640  
[dhines@cityofpittston.org](mailto:dhines@cityofpittston.org)

Michael A. Lombardo, Chairperson  
City of Pittston  
Pittston City Hall  
35 Broad St.  
Pittston, PA 18640  
[mayorlombardo@cityofpittston.org](mailto:mayorlombardo@cityofpittston.org)

Al Zuba  
Frontier  
300E Laird St.  
Wilkes Barre, PA 18702  
[Albert.zuba@ftr.com](mailto:Albert.zuba@ftr.com)

Linda Taflinger  
PA American Water  
852 Wesley Dr.  
Mechanicsburg, PA 17055  
[Linda.taflinger@amwater.com](mailto:Linda.taflinger@amwater.com)

Rosanne Pagliente  
City of Pittston Sewer  
421 Broad St.  
Pittston, PA 18640  
[ptsewer@comcast.net](mailto:ptsewer@comcast.net)

Charlotte Krupa  
PPL  
827 Hausman Road, LEHSC-2  
Allentown, PA 18104  
[cakrupa@pplweb.com](mailto:cakrupa@pplweb.com)

Craig Smith  
Verizon  
222 South Main St, 6<sup>th</sup> Floor  
Wilkes-Barre PA 18701  
[Craig.m.smith@verizon.com](mailto:Craig.m.smith@verizon.com)

Ralph Bush  
Wyoming Valley Sanitary Authority  
PO Box 33A  
Wilkes-Barre, PA 18512  
[Ralph.bush@wvsa.net](mailto:Ralph.bush@wvsa.net)

John Gillott  
UGI  
150 Power Blvd.  
Archbald, PA 18403  
[jgillott@ugi.com](mailto:jgillott@ugi.com)

Dated this 12th Day of May, 2025 \_\_\_\_\_

  
\_\_\_\_\_  
John E. Pfeiffer  
Grade Crossing Engineer  
PennDOT District 4-0  
55 Keystone Industrial Park  
Dunmore, PA 18512