



**Verizon Pennsylvania LLC
Right of Way Department**

Kathleen Meeks
40 S. Mercer St.
New Castle, PA 16101

Cell: 724-636-9515
Phone: 724-652-6375
Kathleen.Meeks@verizon.com

July 8, 2025

Ms. Rosemary Chiavetta, Secretary
PA Public Utility Commission
P. O. Box 3265
Harrisburg, PA 17105-3265

RE:DOT # 506534T

Henderson Township, Huntingdon County

Dear Ms. Chiavetta:

Enclosed is an application to the PUC for Verizon Pennsylvania LLC to place an aerial fiber optic cable crossing in the Township of Henderson, County of Huntindon and must cross the Norfolk Southern Railroad, in the public right of way of Trough Creek Valley Pike, Crossing #506534T

All parties have been notified.

Sincerely

A handwritten signature in black ink that reads "Kathleen Meeks".

Kathleen Meeks
Engineer III-Specialist

**BEFORE
PENNSYLVANIA PUBLIC UTILITY COMMISSION**

In re: Application of Verizon Pennsylvania LLC for approval to place an aerial fiber optic cable and innerduct located in Henderson Township, Huntingdon County. To complete this work, we must cross Norfolk Southern Railroad in the public right of way of Trough Creek Valley Pike Crossing #506534T

Application
Docket No.

To Pennsylvania Public Utility Commission:

1. The name and address of applicant are
Verizon Pennsylvania LLC
Attn: Kathleen Meeks
40 S. Mercer St.
New Castle, PA 16101

-
2. The name and address of applicant's attorney are

Susan D. Paiva
Assistant General Counsel
900 Race Street
6th Floor
Philadelphia, PA 19107

3. Verizon Pennsylvania LLC requests permission to place an aerial fiber optic cable and innerduct in the Township of Henderson, Huntingdon County. **Projected Start Date for this project is September 10,2025**
4. The proposed construction will involve a placement of an aerial fiber optic cable and innerduct attached to existing poles(Exhibit A).
5. The municipalities and property owners concerned in, or affected by, the crossing alterations are in Exhibit "B".
6. The motoring public and railroad traffic will not be impacted. Verizon Pennsylvania LLC will use normal construction procedures. Normal procedures will be followed including the use of flagmen to maintain normal flow of traffic.
7. The estimated cost of this construction project is \$10,000. Completion Date: October 10, 2025.
8. The construction is necessary or proper for the following reasons: **Subsidized Broadband**

Wherefore, applicant prays your Honorable Commission to approve the application:

Kathleen Meeks

1.36. Verification.

(a) Applications, petitions, formal complaints, motions and answers thereto containing an averment of fact not appearing of record in the action or containing a denial of fact shall be personally verified by a party thereto or by an authorized officer of the party if a corporation or association. Verification means a signed written statement of fact supported by oath or affirmation or made subject to the penalties of 18 Pa. C.S. §4904 (relating to unsworn falsification to authorities). If verification is required, notarization is not necessary.

(b) The Verification form should comply substantially with the following:

VERIFICATION

I, Kathleen Meeks, hereby state that the facts above set forth are true and correct (or are true and correct to the best of my knowledge, information and belief) and that I expect to be able to prove the same at a hearing held in this matter. I understand that the statements herein are made subject to the penalties of 18 Pa. C.S. § 4904 (relating to unsworn falsification to authorities).

Date: 7/8/2025 Kathleen Meeks
(Signature)

CERTIFICATE OF SERVICE
Exhibit B

I hereby certify that I have this day served a true copy of the foregoing document upon the participants, listed below, in accordance with the requirements of § 1.54

Daniel D. Leonard, P.E. | Grade Crossing Engineer
PA Department of Transportation | Bureau of Project Delivery
Highway Delivery Division | Utilities and Right-of-Way Section
400 North Street, 7th Floor | Harrisburg, PA 17120
danleonard@pa.gov

Karen Cummings
Senior Assistant Counsel
Governors Office of General Counsel
Department of Transportation
Office of Chief Counsel/Real Property Division
P.O. Box 8212, Harrisburg, PA 17105-8212
kcummings@pa.gov

Pennsylvania Department of Transportation District 9
1620 N. Juniata Street
Hollidaysburg, PA 16648

Patrick Reeder President / Chairperson Huntingdon County
233 Penn Street
Huntingdon, PA 16652
preeder@huntingdoncounty.net

Henderson Township
President / Chairperson
Teresa L. Laird
PO Box 356
Huntingdon, PA 16652
henderson.twp@gmail.com

Norfolk Southern Railway Company
Attn: Engineering/Permitting
Three Commercial Place
Norfolk, VA 23510
ns.info@railpros.com

Dated this 8th day of July, 2025





METHOD: AERIAL CROSSING
 MUNICIPALITY: HENDERSON TOWNSHIP
 COUNTY: HUNTINGDON
 CROSSING NUMBER: 506534T
 LAT: 40.4421422
 LONG: -77.9440759

**FLAGGING
 REQUIRED**

NORFOLK SOUTHERN RAILWAY
 PERMIT SKETCH
 1A6HQ9X

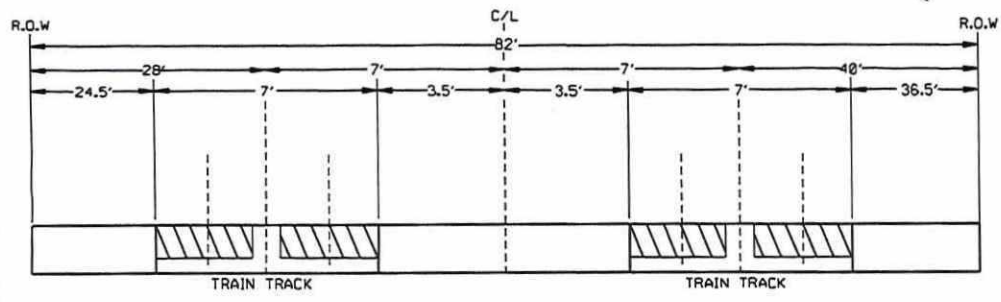
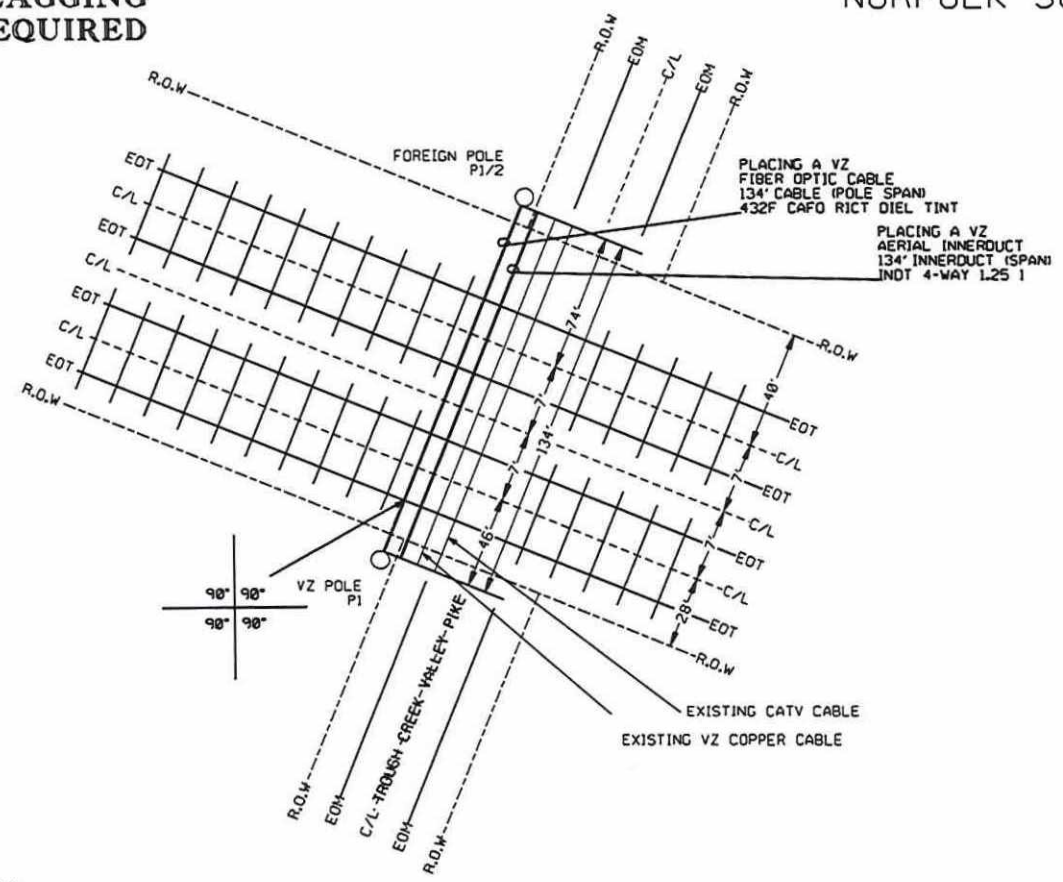

PRINT 1 OF 2
 NOT TO SCALE





NORFOLK SOUTHERN RAILWAY PERMIT SKETCH 1A6HQ9X

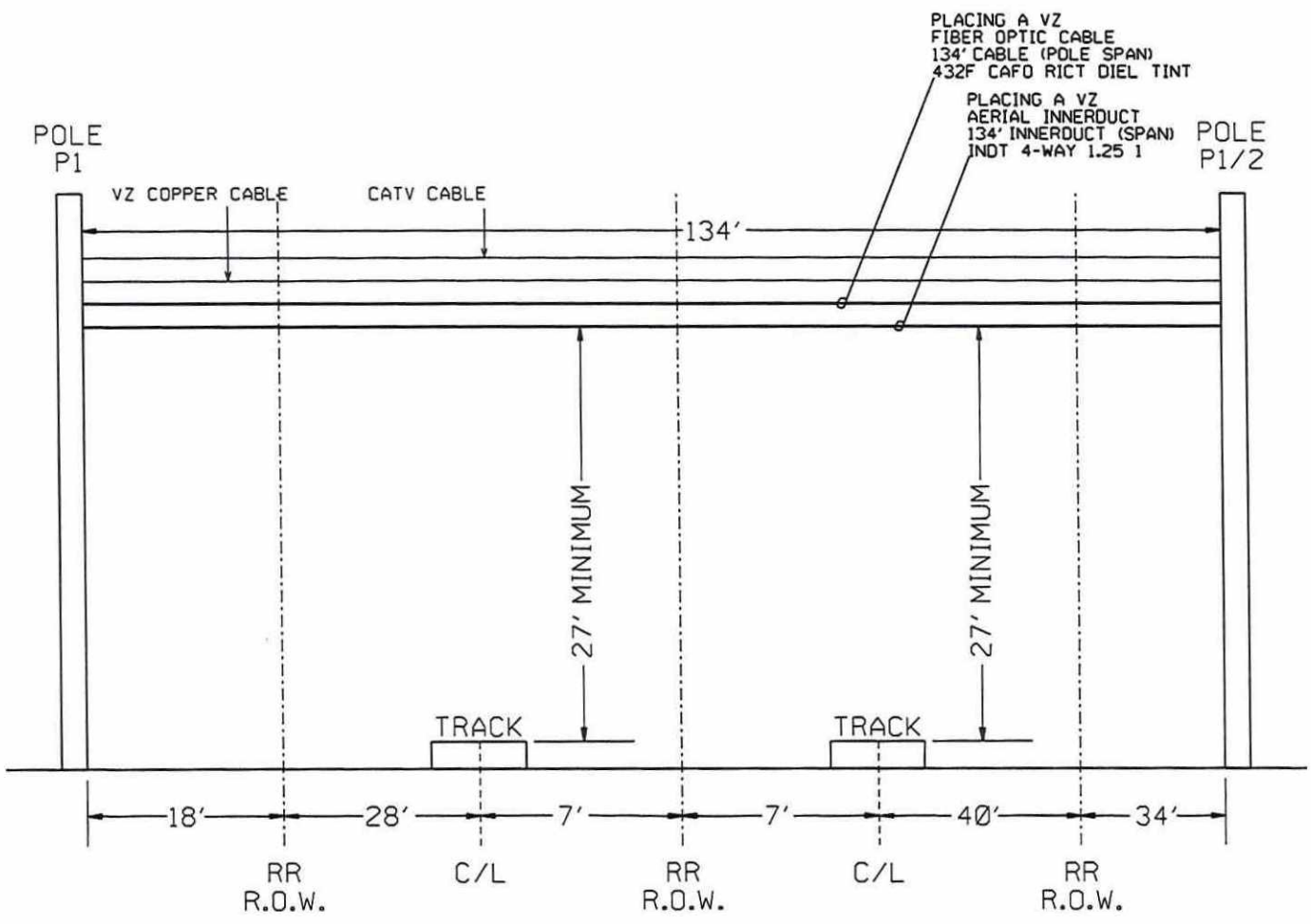

PRINT 2 OF 2
NOT TO SCALE

