



August 14, 2025

Matthew Homsher, Secretary
Pennsylvania Public Utility Commission
400 North Street
Harrisburg, PA 17120

Re: Application of the Department of Transportation of the Commonwealth of Pennsylvania for approval to rehabilitate the existing bridges where State Route 0079 crosses above the track(s) of CSX at DOT Nos. 928 612N, 937 659H, 928 615J, 928 609F & Norfolk Southern at DOT Nos. 955 900E and 955 901L in the City of Erie, Erie County, and the allocation of costs incident thereto.

Dear Secretary Homsher,

Enclosed for filing, please find the Application of the Department of Transportation.

A copy of this Application and Exhibits has been served upon the parties in the Certificate of Service to the Application by email.

Sincerely,

Mohammad Arghoshi

Digitally signed by marghoshi
Date: 2025.08.14 15:07:56
-04'00'

Mohammad A. Arghoshi
Senior Civil Engineer|DGCE
Engineering District 1-0
Department of Transportation

Attachments

cc: Parties of Record
Mark J. Chappell, P.E., Chief Bureau of Design & Delivery, Utilities & Grade Crossing
Division Karen L. Cummings, Office of Chief Counsel
William M. Sinick, P.E., Supervisor, Rail Safety Engineering Section, PUC

**BEFORE THE
PENNSYLVANIA PUBLIC UTILITY COMMISSION**

Application of the Department of Transportation of the Commonwealth of Pennsylvania for approval to rehabilitate the existing bridges where State Route 0079 crosses above the track(s) of CSX at DOT Nos. 928 612N, 937 659H, 928 615J, 928 609F & Norfolk Southern at DOT Nos. 955 900E and 955 901L in the City of Erie, Erie County, and the allocation of costs incident thereto.

Application
Docket No. _____

Electronically Filed

APPLICATION OF THE COMMONWEALTH OF PENNSYLVANIA, DEPARTMENT OF
TRANSPORTATION

Applicant, Commonwealth of Pennsylvania, Department of Transportation, files this Application pursuant to the provisions of 66 Pa.C.S § 2702 and 52 Pa. Code § 5.13 to rehabilitate the existing two bridges where on State Route 0079 crosses above the track(s) of CSX DOT Nos. 928 612N, 937 659H, 928 615J, 928 609F & NS Railroad Company DOT Nos. 955 900E and 955 901L in the City of Erie, Erie County as described below:

1. The name and address of Applicant are Commonwealth of Pennsylvania, Department of Transportation, Thomas J. McClelland, P.E., Assistant District Executive, Engineering District 1-0, 255 Elm Street, Oil City, PA 16301.

2. The name and address of attorney for the Applicant are Caroline G. Robelen, Assistant Counsel, Commonwealth of Pennsylvania, Department of Transportation, Office of Chief Counsel, PO Box 8212, Harrisburg, PA 17105-8212.

3. The Applicant is an agency of Commonwealth of Pennsylvania, organized and existing under the Administrative Code of 1929, 71 P.S. § 511, et seq. and generally 36 P.S. § 670 - 401 et seq.
4. The names and addresses of the persons, parties and entities concerned in, or affected by the proposed construction, to the best of the Applicant’s knowledge, are shown in the certificate of service. In addition to those served, the Applicant requests that the following also receive service of all documents in this matter:

Mark J. Chappell, P.E., Acting Director
 Bureau of Design & Delivery, Utilities &
 Grade Crossing Division
 Pennsylvania Department of Transportation
 PO Box 3362
 Harrisburg, PA 17105-3362
babasom@pa.gov

Karen L. Cummings
 Office of Chief Counsel
 Pennsylvania Department of Transportation
 PO Box 8212
 Harrisburg, PA 17105-8212
kcummings@pa.gov

5. The Applicant is seeking approval to replace the two existing bridges where on State Route 0079 crosses above the track(s) of CSX & NS Railroad Company. A Location Map is attached hereto and marked as Exhibit “A”. Also, the Type, Size and Location Plans are attached hereto and marked as Exhibit “B”.
6. The Applicant is not aware of prior Public Utility Commission proceedings for this crossing.
7. The average daily traffic for State Route 0079, Section B09 at these crossings are.

No.	Highway	DOT No.	AADT	Percent of Trucks
1	I -79-B09	928 612N	2023	6
2	I -79-B09	937 659H	2023	6
3	I -79-B09	928 615J	2023	6
4	I -79-B09	928 609F	2023	6
4	I -79-B09	955 900E	2023	6
6	I -79-B09	955 901L	2023	6

8. The estimated cost of the project described above is \$53,000,000. It is anticipated that the funding for the project will be state funds.

9. This project is necessary and proper for the safety and convenience of the public.

10. A conference of all parties of interest should be held to discuss the proposed project.

Wherefore, Applicant respectfully requests that the Public Utility Commission approve this Application.

Respectfully Submitted:

Thomas J McClelland 2025.08.14
14:51:57 -04'00'

Thomas J. McClelland, P.E.
Assistant District Executive-Design
Engineering District 1-0
Department of Transportation
255 Elm Street
Oil City, PA 16301
Phone: (814) 678-7081
Fax: (814) 678-7030
THMCCLELLA@pa.gov

Dated: _____

**BEFORE THE
PENNSYLVANIA PUBLIC UTILITY COMMISSION**

Application of the Department of Transportation of the Commonwealth of Pennsylvania for approval to rehabilitate the existing bridges where State Route 0079 crosses above the track(s) of CSX at DOT Nos. 928 612N, 937 659H, 928 615J, 928 609F & Norfolk Southern at DOT Nos. 955 900E and 955 901L in the City of Erie, Erie County, and the allocation of costs incident thereto.

Application
Docket No. _____

Electronically Filed

CERTIFICATE OF SERVICE

I hereby certify that I have this day served a true copy of the foregoing document upon the participants listed below, in accordance with the requirements of 52 Pa. Code § 1.54, by electronic mail:

Shawn Starling, P.E.
Senior Engineer Public Improvements
Norfolk Southern Railway Company
Engineering - Design & Construction
650 West Peachtree Street NW - Box 45
Atlanta, GA 30308
Douglas.Starling@nscorp.com

Noah Vroman
Pennsylvania Electric Company
5404 Evans Rd. P.O. Box 1101
Erie, PA 16558
814-868-8882
nvroman@firstenergycorp.com

Michael Sliper
Project Manager II
CSX Public Projects
P. 518.767.6081. F. 904.306.5476
1 Bell Crossing, Selkirk, NY 12158
Michael_Sliper@csx.com

Eric Rodrigues
Verizon North LLC
20 East 10th Street
Erie, PA 16501
eric.rodrigues@verizon.com

c/o CT Corporation System
600 North Second Street, Suite 401
Harrisburg, PA 17101

Robert Duran
Erie Water Works
240 West 12th St.
P.O. Box 6179
Erie, PA 16501
814-870-8000 ext.209
rduran@eriewaterworks.org

Ellen Schauerman
Erie County Council Member
140 West Sixth St.
Erie, PA 16501
eschauerman@eriecountypa.gov

Jason Sayers
Erie City Bureau of Sewers
626 State St. Room 400
Erie, PA 16501
814-870-1397
jsayers@erie.pa.us

Jasmine Flores
President / Chairperson
626 State Street, Room 104
City of Erie, PA 16501
JFlores@erie.pa.us

Shawn Kottwitz
Zito Media Communications, LLC
102 South Main St. 2nd floor
Coudersport, PA 16915
814-320-3684
shawn.kottwitz@zitomedia.com

Mr. Noah Vroman
Pennsylvania Electric Company
5404 Evans Rd. P.O. Box 1101
Erie, PA 16558
814-868-8882
nvroman@firstenergycorp.com

Dated this 14 Day of August, 2025

Mohammad Arghoshi  Digitally signed by marghoshi
Date: 2025.08.14 15:08:21
-04'00'

Mohammad A. Arghoshi
Senior Civil Engineer|DGCE
Engineering District 1-0
Department of Transportation

**BEFORE THE
PENNSYLVANIA PUBLIC UTILITY COMMISSION**

Application of the Department of Transportation of the Commonwealth of Pennsylvania for approval to rehabilitate the existing bridges where State Route 0079 crosses above the track(s) of CSX at DOT Nos. 928 612N, 937 659H, 928 615J, 928 609F & Norfolk Southern at DOT Nos. 955 900E and 955 901L in the City of Erie, Erie County, and the allocation of costs incident thereto.

Application
Docket No. _____

Electronically Filed

VERIFICATION

I, Mohammad Arghoshi, Grade Crossing Engineer, hereby state that the facts above set forth are true and correct to the best of my knowledge, information, and belief and that I expect to be able to prove the same at a hearing held in this matter. I understand that the statements herein are made subject to the penalties of 18 Pa.C.S. §4904 (relating to unsworn falsification to authorities).

Date: _____

Digitally signed by marghoshi
Date: 2025.08.14 15:09:01
-04'00'

Mohammad A. Arghoshi
Senior Civil Engineer|DGCE
Engineering District 1-0
Department of Transportation

Location: City of Erie, Erie County

I -79, Section B09

Railroad Name: Norfolk Southern Railway Company, DOT # 955900E & 955901L and CSX Transportation, Inc.
Dot # 928612N,937659H,928615J & 928609F

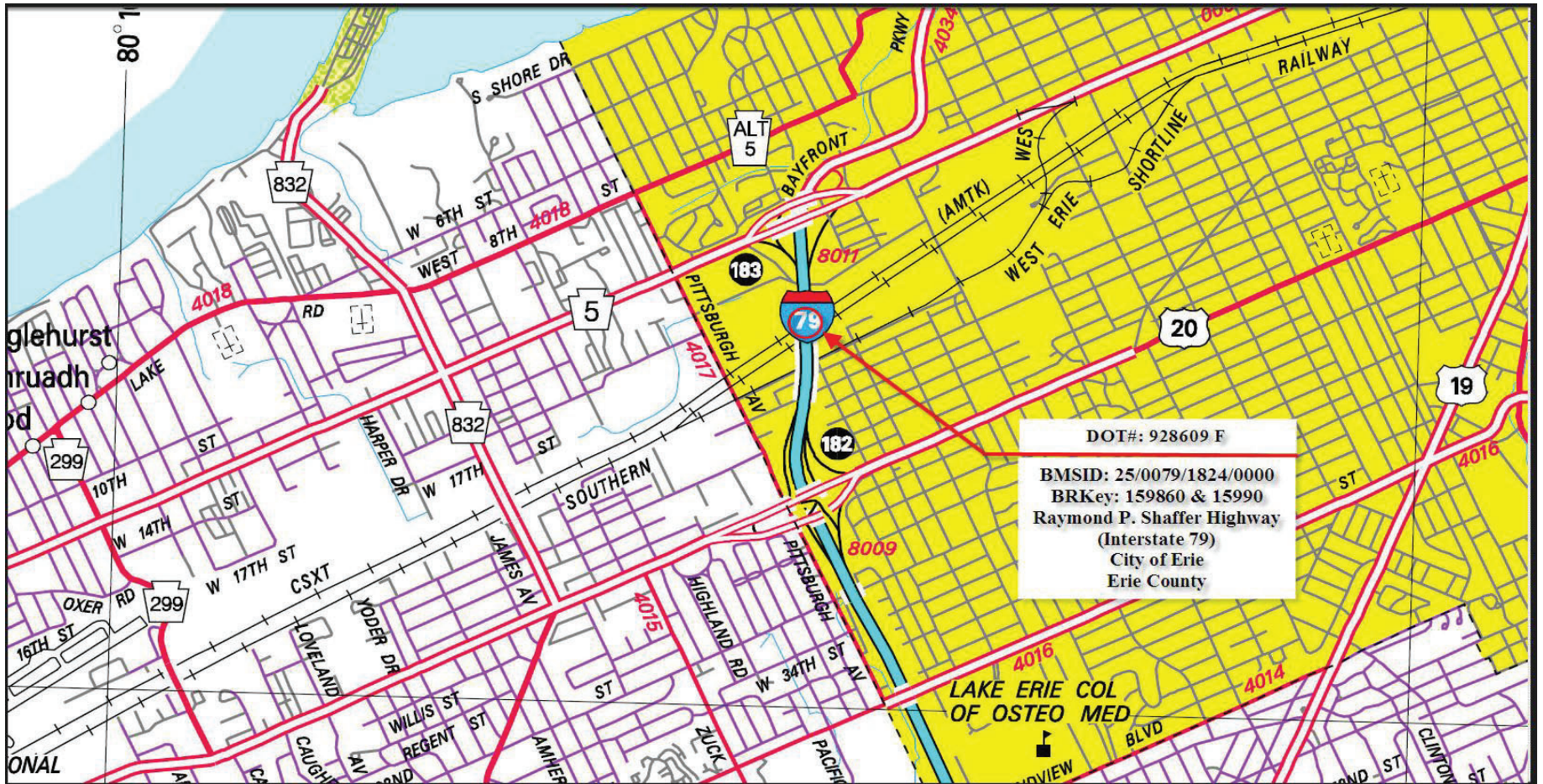

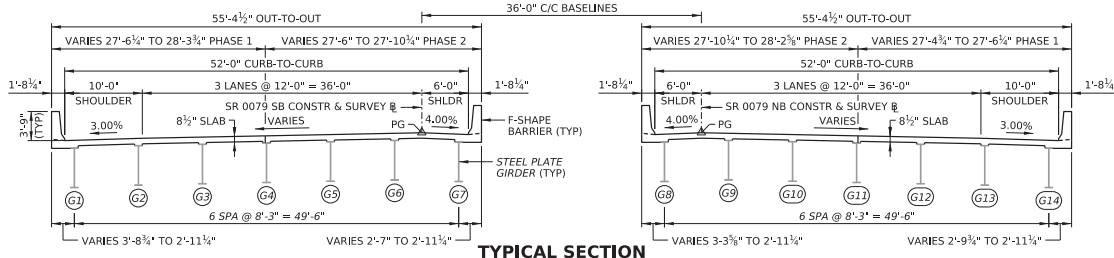

TYPICAL SECTION

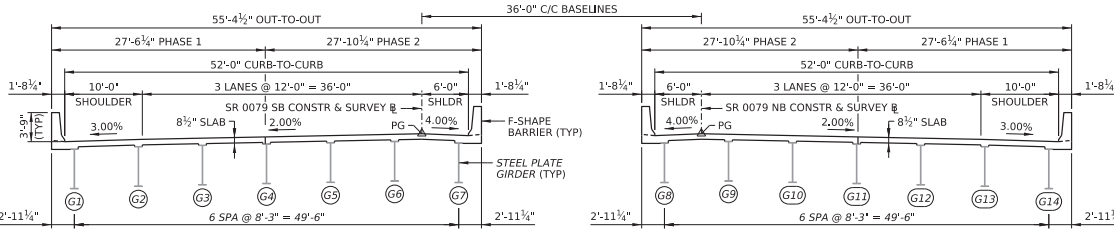
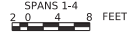

TYPICAL SECTION

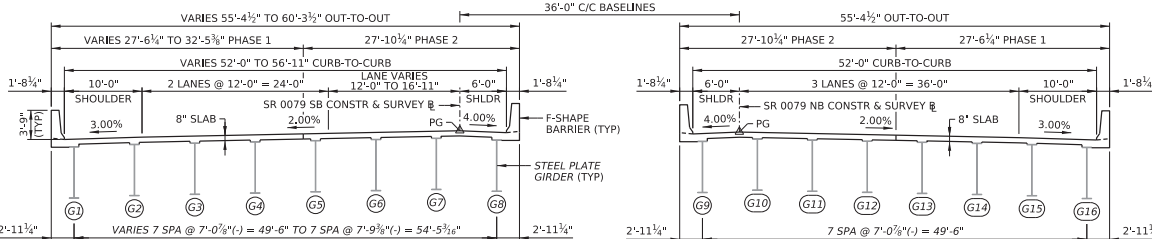
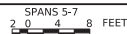

TYPICAL SECTION

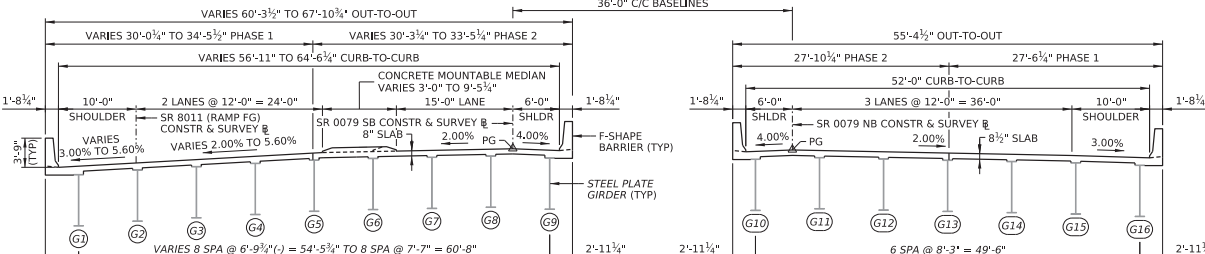
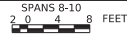

TYPICAL SECTION

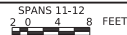

- NOTES:**
1. FOR PROTECTIVE FENCING LIMITS, SEE SHEETS 1 & 2.
 2. FOR PROJECT SCOPE OF WORK, SEE SHEET 2.
 3. FOR CONSTRUCTION PHASING SECTIONS, SEE SHEETS 4-9.

Mark	Description	By	Chk'd	Recm'd.	Date
REVISIONS					

S.R. 0079 PREVIOUSLY KNOWN AS LR. 1003
 BMS STR ID: 25-0079-1824-0000 (NB) BRKEY: 15986 (NB)
 BMS STR ID: 25-0079-1825-0002 (SB) MPMS/ECMS PROJ: 115467 BRKEY: 15990 (SB)

COMMONWEALTH OF PENNSYLVANIA
DEPARTMENT OF TRANSPORTATION
ERIE COUNTY
S.R. 0079, SECTION B09
 SEGMENT 1824, OFFSET 0000, S.R. 0079 NB STA 369+35.00
 SEGMENT 1825, OFFSET 0042, S.R. 0079 SB STA 369+40.00
 OVER CSX & NORFOLK SOUTHERN RAILROADS, IRWIN DRIVE,
 RUDOLPH AVENUE, AND WEST 16TH STREET
REHABILITATION OF DUAL 2-SPAN STEEL PLATE GIRDER BRIDGES
TYPICAL SECTIONS

RECOMMENDED _____	SHEET <u>3</u> OF <u>9</u>
	S - 42755

PLOTTED: 16-JAN-2025 2:02:24

OPERATOR: FILE NAME: bwz\wsp-us-pw-bentley.com\wsp-us-pw-02\Documents\PA Transportation\PermDOT\District 1-079000000.006_SR19\STR\TSU\Plans\73_p01.dgn

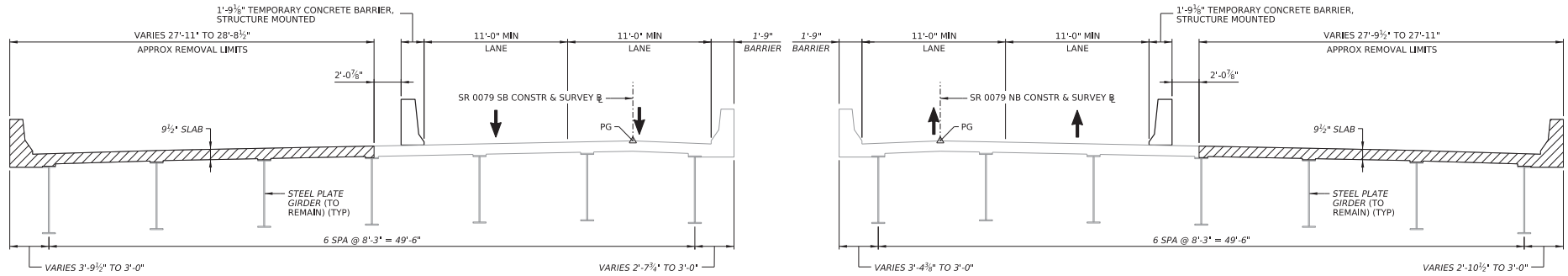

PHASE 1 - REMOVAL

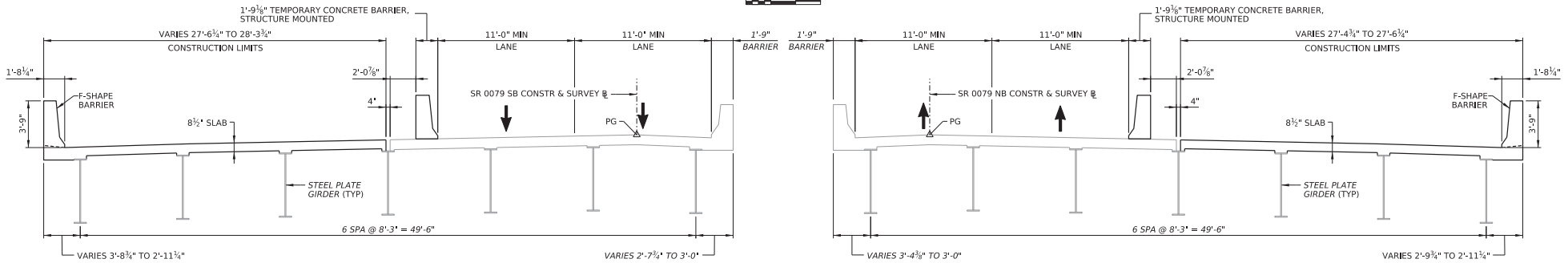
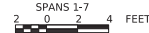

PHASE 1 - CONSTRUCTION

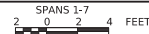

LEGEND:

- REMOVAL LIMITS FOR EXISTING STRUCTURE

NOTES:

1. PROVIDE TYPE 1 INSTALLATION AS PER BC-719M.

Mark	Description	By	Chk'd	Recm'd.	Date
REVISIONS					

S.R. 0079 PREVIOUSLY KNOWN AS L.R. 1003
 BMS STR ID: 25-0079-1824-0000 (NB) BRKEY: 15986 (NB)
 BMS STR ID: 25-0079-1825-0002 (SB) MPMS/ECMS PROJ: 115467 BRKEY: 15990 (SB)

COMMONWEALTH OF PENNSYLVANIA
DEPARTMENT OF TRANSPORTATION

ERIE COUNTY
S.R. 0079, SECTION B09
 SEGMENT 1824, OFFSET 0000, S.R. 0079 NB STA 369+35.00
 SEGMENT 1825, OFFSET 0042, S.R. 0079 SB STA 369+40.00
 OVER CSX & NORFOLK SOUTHERN RAILROADS, IRWIN DRIVE,
 RUDOLPH AVENUE, AND WEST 16TH STREET
 REHABILITATION OF DUAL 12-SPAN STEEL PLATE GIRDER BRIDGES

CONSTRUCTION PHASING SECTIONS - 1

RECOMMENDED _____	SHEET <u>4</u> OF <u>9</u>
	S - 42755

PLOTTED: 16-JAN-2025 20:24

OPERATOR: FILE NAME: pwwz/wsp-us-pw-bentley.com/wsp-us-pw-02/Documents/PA Transportation/PermDOT/District 1-079900800.006_SR79/STR/TSU/Plans/73_p02.dgn

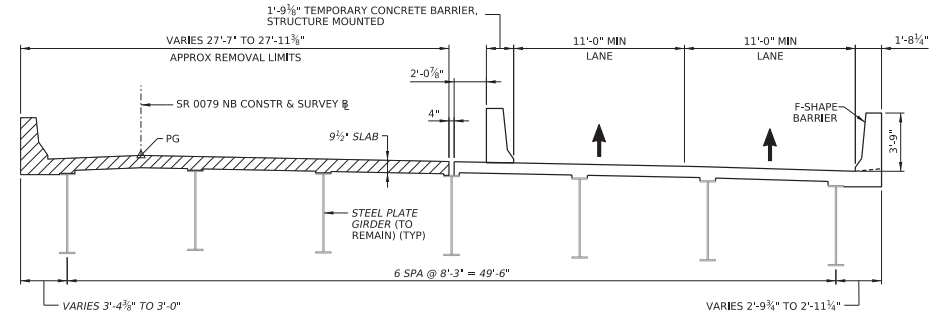
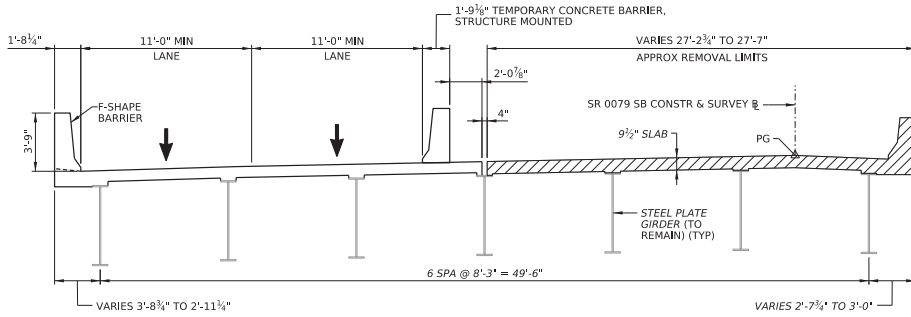

PHASE 2 - REMOVAL

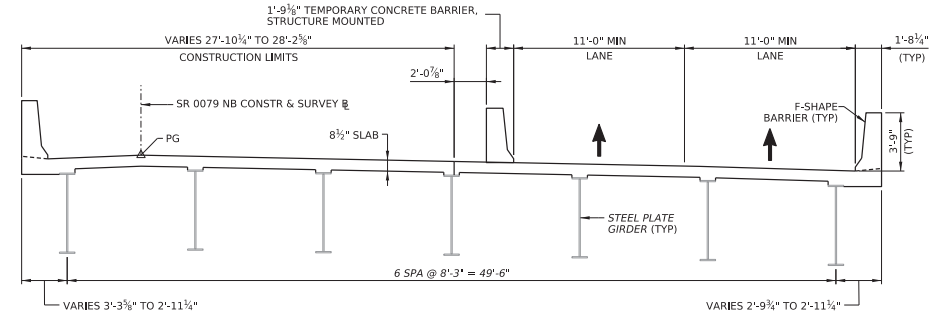
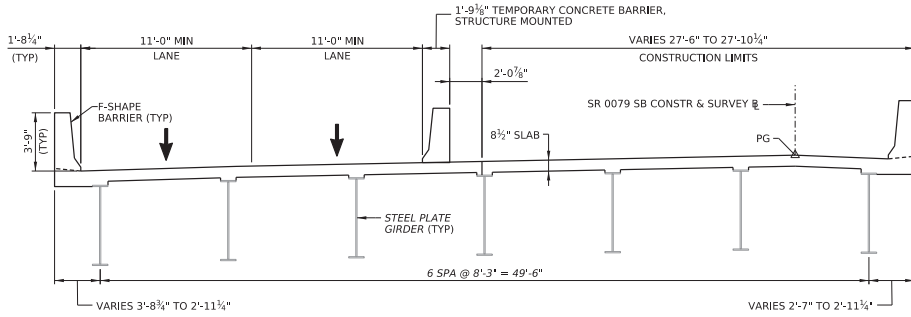

PHASE 2 - CONSTRUCTION

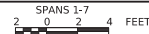

LEGEND:

- REMOVAL LIMITS FOR EXISTING STRUCTURE

NOTES:

1. PROVIDE TYPE 1 INSTALLATION AS PER BC-719M.

Mark	Description	By	Chk'd	Recm'd.	Date
REVISIONS					

S.R. 0079 PREVIOUSLY KNOWN AS L.R. 1003
 BMS STR ID: 25-0079-1824-0000 (NB) MPMS/ECMS PROJ: 115467 BRKEY: 15986 (NB)
 BMS STR ID: 25-0079-1825-0002 (SB) BRKEY: 15990 (SB)

COMMONWEALTH OF PENNSYLVANIA
DEPARTMENT OF TRANSPORTATION

ERIE COUNTY
S.R. 0079, SECTION B09

SEGMENT 1824, OFFSET 0000, S.R. 0079 NB STA 369+35.00
 SEGMENT 1825, OFFSET 0042, S.R. 0079 SB STA 369+40.00
 OVER CSX & NORFOLK SOUTHERN RAILROADS, IRWIN DRIVE,
 RUDOLPH AVENUE, AND WEST 16TH STREET
 REHABILITATION OF DUAL 12-SPAN STEEL PLATE GIRDER BRIDGES

CONSTRUCTION PHASING SECTIONS - 2

RECOMMENDED _____	SHEET 5 OF 9
S - 42755	

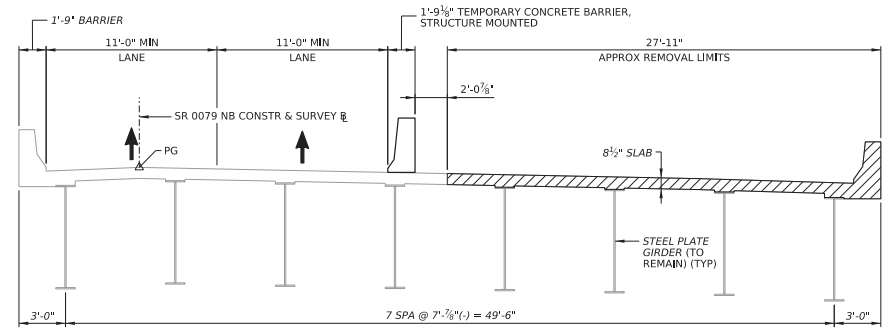
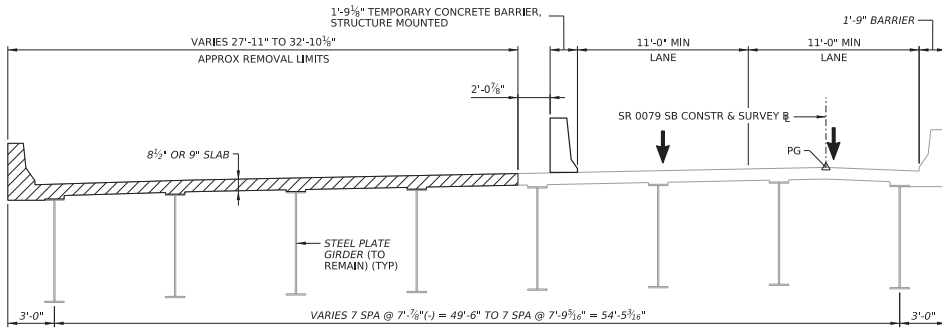

PHASE 1 - REMOVAL

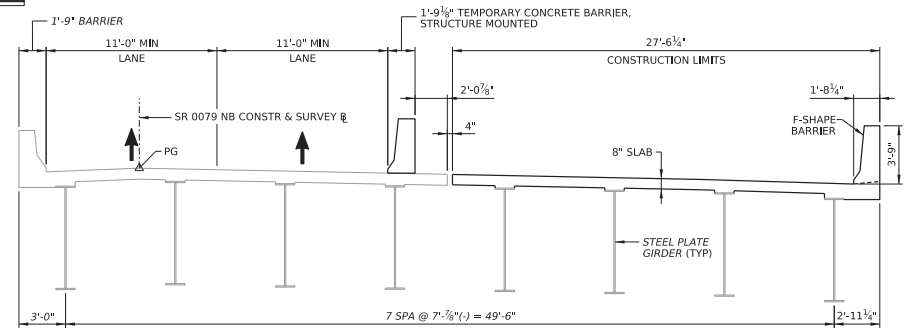
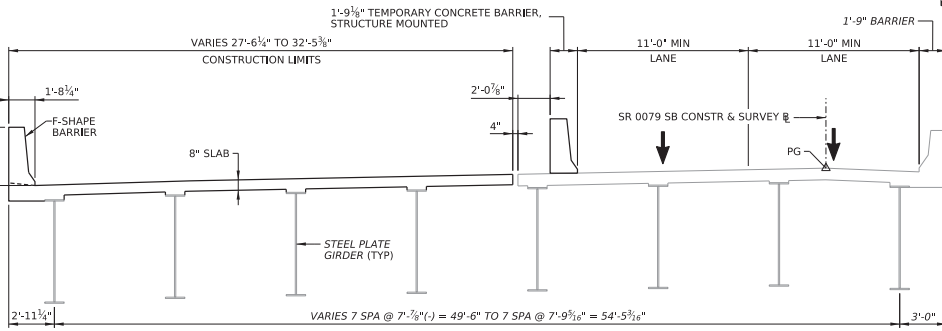
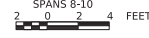

PHASE 1 - CONSTRUCTION

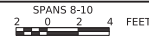

LEGEND:

- REMOVAL LIMITS FOR EXISTING STRUCTURE

NOTES:

1. PROVIDE TYPE 1 INSTALLATION AS PER BC-719M.

Mark	Description	By	Chk'd	Recm'd.	Date
REVISIONS					

S.R. 0079 PREVIOUSLY KNOWN AS L.R. 1003
 BMS STR ID: 25-0079-1824-0000 (NB) MPMS/ECMS PROJ: 115467 BRKEY: 15986 (NB)
 BMS STR ID: 25-0079-1825-0002 (SB) BRKEY: 15990 (SB)

**COMMONWEALTH OF PENNSYLVANIA
DEPARTMENT OF TRANSPORTATION**

**ERIE COUNTY
S.R. 0079, SECTION B09**

SEGMENT 1824, OFFSET 0000, S.R. 0079 NB STA 369+35.00
 SEGMENT 1825, OFFSET 0042, S.R. 0079 SB STA 369+40.00
 OVER CSX & NORFOLK SOUTHERN RAILROADS, IRWIN DRIVE,
 RUDOLPH AVENUE, AND WEST 16TH STREET
 REHABILITATION OF DUAL 12-SPAN STEEL PLATE GIRDER BRIDGES

CONSTRUCTION PHASING SECTIONS - 3

RECOMMENDED _____	SHEET 6 OF 9
	S - 42755

PLOTTED: 16-JAN-2025 20:25

OPERATOR: FILE NAME: bww/nsp-us-pw-bentley.com/wsp-us-pw-02/Documents/PA Transportation/PermDOT/District 1-070900000.006_SR79/STR/TSU/Plans/73_p04.dgn

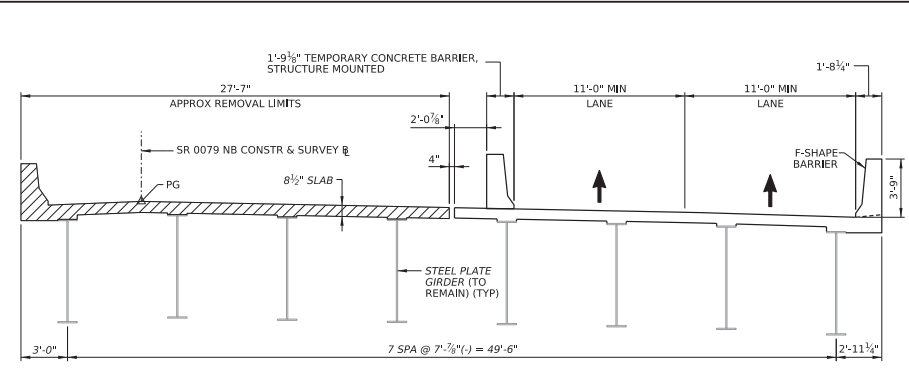
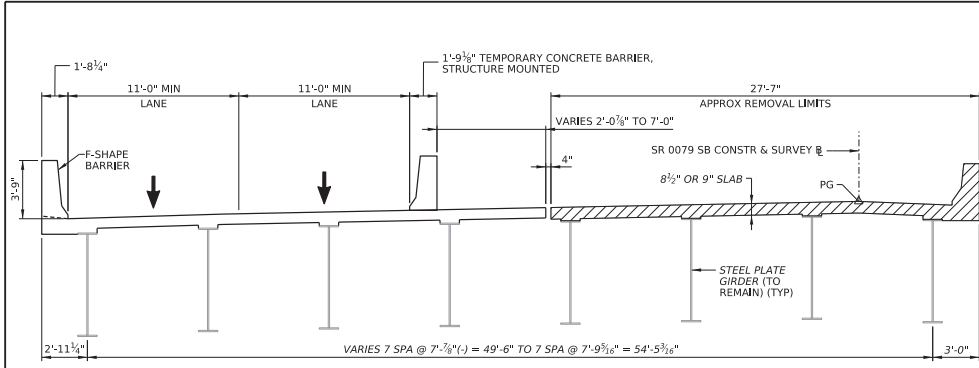

PHASE 2 - REMOVAL

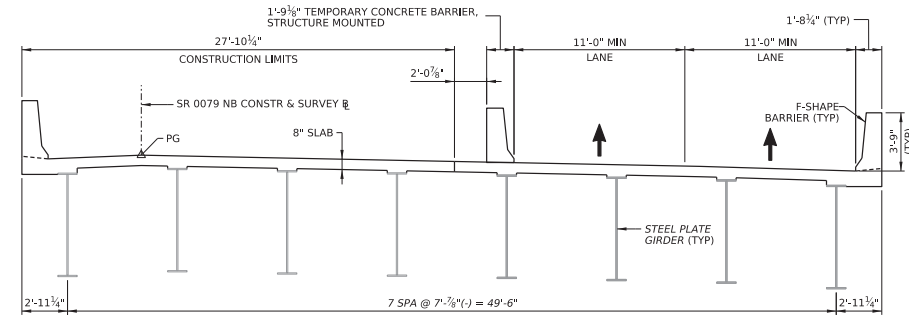
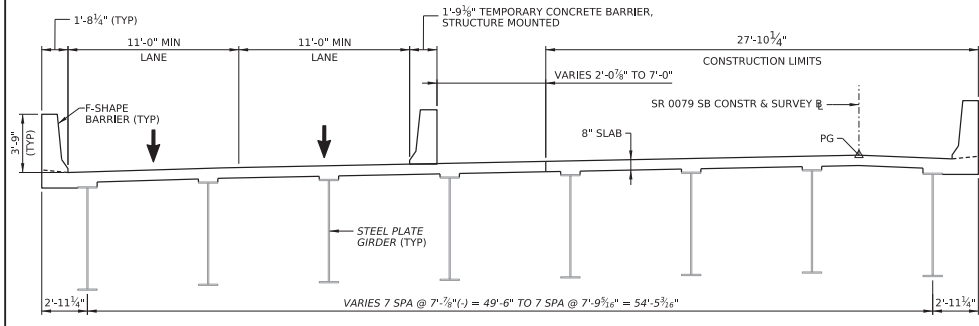

PHASE 2 - CONSTRUCTION



LEGEND:

- REMOVAL LIMITS FOR EXISTING STRUCTURE

NOTES:

1. PROVIDE TYPE 1 INSTALLATION AS PER BC-719M.

Mark	Description	By	Chk'd	Recm'd.	Date
REVISIONS					

S.R. 0079 PREVIOUSLY KNOWN AS L.R. 1003
 BMS STR ID: 25-0079-1824-0000 (NB) MPMS/ECMS PROJ: 115467 BRKEY: 15986 (NB)
 BMS STR ID: 25-0079-1825-0002 (SB) BRKEY: 15990 (SB)

COMMONWEALTH OF PENNSYLVANIA
DEPARTMENT OF TRANSPORTATION

ERIE COUNTY
S.R. 0079, SECTION B09
 SEGMENT 1824, OFFSET 0000, S.R. 0079 NB STA 369+35.00
 SEGMENT 1825, OFFSET 0042, S.R. 0079 SB STA 369+40.00
 OVER CSX & NORFOLK SOUTHERN RAILROADS, IRWIN DRIVE,
 RUDOLPH AVENUE, AND WEST 16TH STREET
 REHABILITATION OF DUAL 12-SPAN STEEL PLATE GIRDER BRIDGES

CONSTRUCTION PHASING SECTIONS - 4

RECOMMENDED _____	SHEET <u>7</u> OF <u>9</u>
	S - 42755

DES: GJS	CKD: JMW	DWG: GJS	CKD: JMW
----------	----------	----------	----------

PLOTTED: 16-JAN-2025 20:25

OPERATOR: FILE NAME: bww/nsp-us-pw-bentley.com/wsp-us-pw-02/Documents/PA Transportation/PermDOT/District 1-0790900800.006_SR79/STR/TSU/Plans/79_p05.dgn

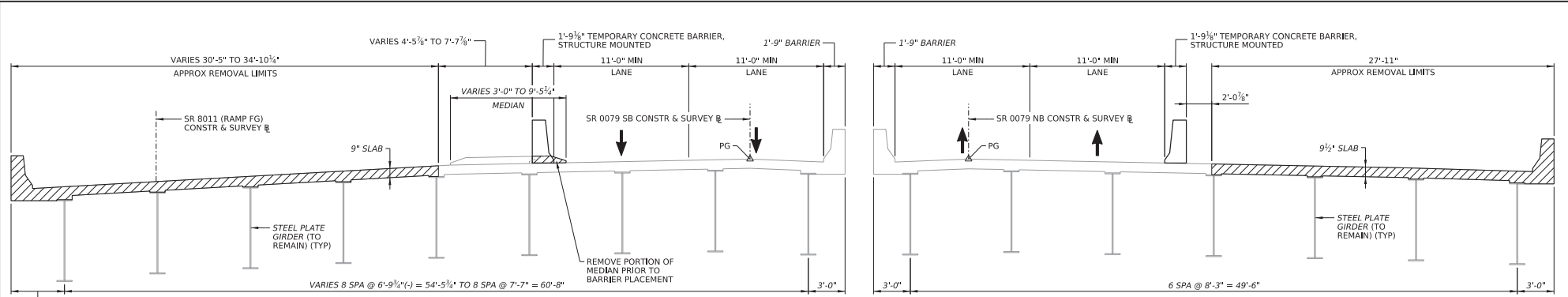

PHASE 1 - REMOVAL

SPANS 11-12
2 0 2 4 FEET

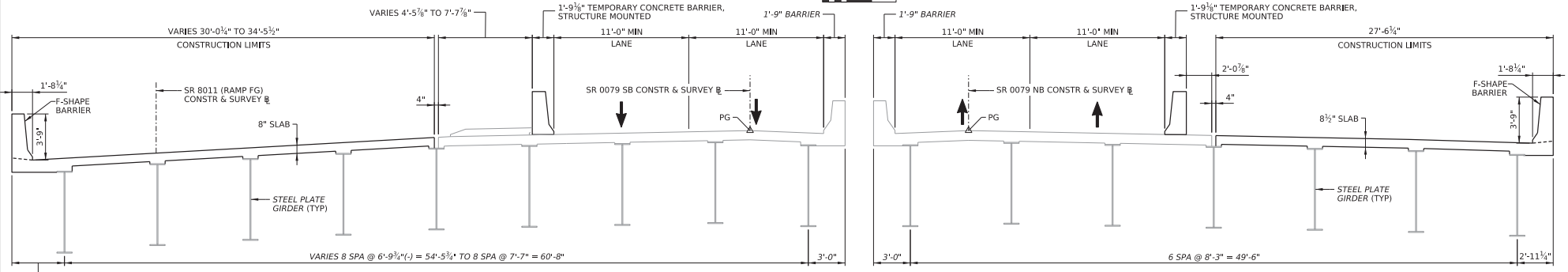

PHASE 1 - CONSTRUCTION

SPANS 11-12
2 0 2 4 FEET

LEGEND:

- REMOVAL LIMITS FOR EXISTING STRUCTURE

NOTES:

1. PROVIDE TYPE 1 INSTALLATION AS PER BC-719M.

Mark	Description	By	Chk'd	Recm'd.	Date
REVISIONS					

S.R. 0079 PREVIOUSLY KNOWN AS L.R. 1003
 BMS STR ID: 25-0079-1824-0000 (NB) BRKEY: 15986 (NB)
 BMS STR ID: 25-0079-1825-0002 (SB) MPMS/ECMS PROJ: 115467 BRKEY: 15990 (SB)

COMMONWEALTH OF PENNSYLVANIA
DEPARTMENT OF TRANSPORTATION

ERIE COUNTY
S.R. 0079, SECTION B09

SEGMENT 1824, OFFSET 0000, S.R. 0079 NB STA 369+35.00
 SEGMENT 1825, OFFSET 0042, S.R. 0079 SB STA 369+40.00
 OVER CSX & NORFOLK SOUTHERN RAILROADS, IRWIN DRIVE,
 RUDOLPH AVENUE, AND WEST 16TH STREET
 REHABILITATION OF DUAL 12-SPAN STEEL PLATE GIRDER BRIDGES

CONSTRUCTION PHASING SECTIONS - 5

RECOMMENDED _____	SHEET 8 OF 9
	S - 42755

DES: GJS	CKD: JMW	DWG: GJS	CKD: JMW
----------	----------	----------	----------

PLOTTED: 16-JAN-2025 2:02:25

OPERATOR: FILE NAME: bw2/wsp-us-pw-bentley.com/wsp-us-pw-02/Documents/PA Transportation/PermDOT/District 1-079090000.006_SR19/STR/TSU/Plans/73_p0606.dgn

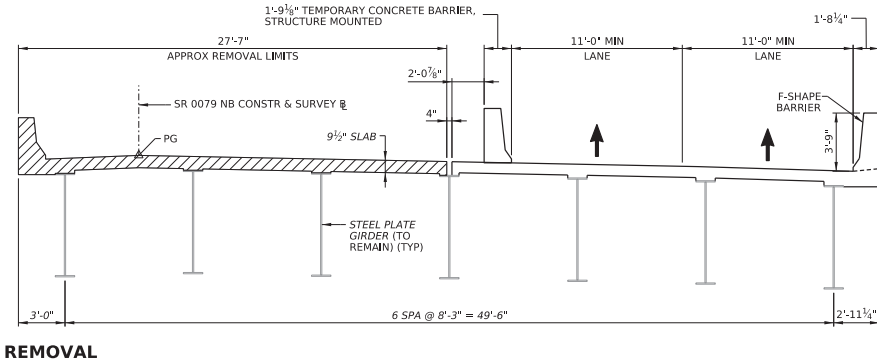
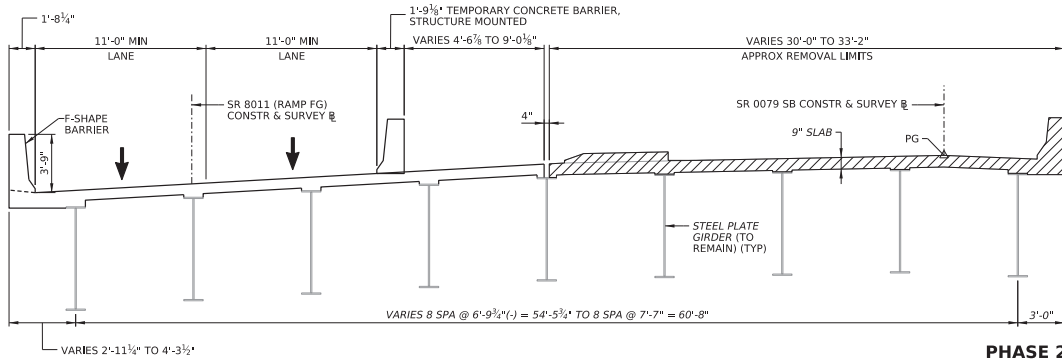

PHASE 2 - REMOVAL

SPANS 11-12
2 0 2 4 FEET

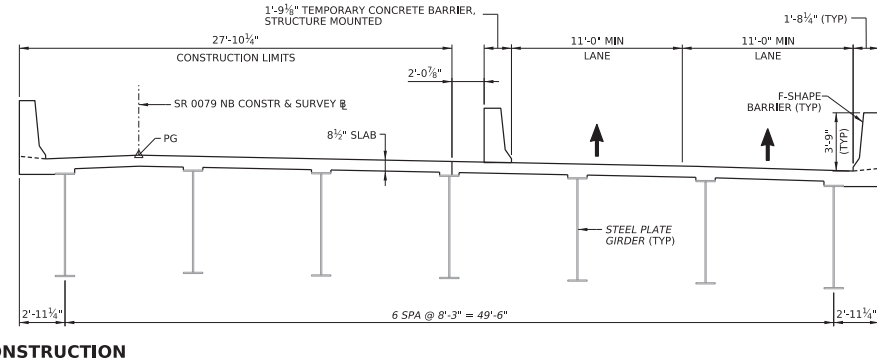
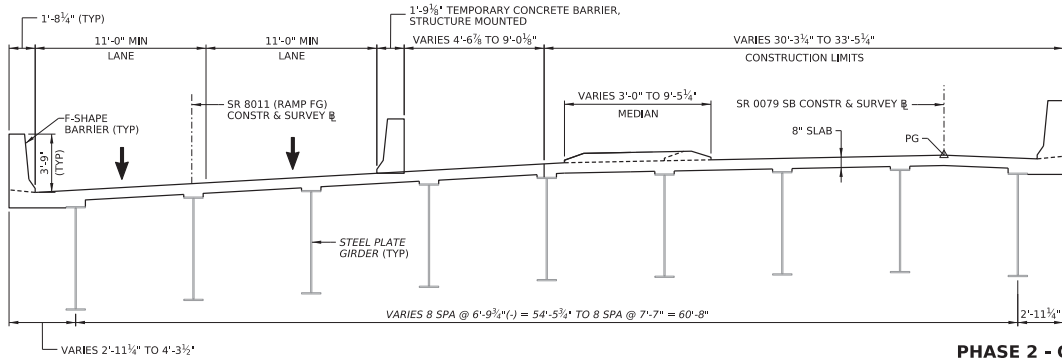

PHASE 2 - CONSTRUCTION

SPANS 11-12
2 0 2 4 FEET

LEGEND:

- REMOVAL LIMITS FOR EXISTING STRUCTURE

NOTES:

1. PROVIDE TYPE 1 INSTALLATION AS PER BC-719M.

Mark	Description	By	Chk'd	Recm'd.	Date
REVISIONS					

S.R. 0079 PREVIOUSLY KNOWN AS L.R. 1003
 BMS STR ID: 25-0079-1824-0000 (NB) MPMS/ECMS PROJ: 115467 BRKEY: 15986 (NB)
 BMS STR ID: 25-0079-1825-0002 (SB) BRKEY: 15990 (SB)

COMMONWEALTH OF PENNSYLVANIA
DEPARTMENT OF TRANSPORTATION

ERIE COUNTY
S.R. 0079, SECTION B09
 SEGMENT 1824, OFFSET 0000, S.R. 0079 NB STA 369+35.00
 SEGMENT 1825, OFFSET 0042, S.R. 0079 SB STA 369+40.00
 OVER CSX & NORFOLK SOUTHERN RAILROADS, IRWIN DRIVE,
 RUDOLPH AVENUE, AND WEST 16TH STREET
 REHABILITATION OF DUAL 12-SPAN STEEL PLATE GIRDER BRIDGES

CONSTRUCTION PHASING SECTIONS - 6

RECOMMENDED _____	SHEET 9 OF 9
	S - 42755

DES: GJS	CKD: JMW	DWG: GJS	CKD: JMW
----------	----------	----------	----------