

Tabatha Smith
Lead Engineering Coordinator

(717) 408 – 9112
tabatha@americomm-llc.com

October 2, 2025

VIA ELECTRONIC FILING

Rosemary Chiavetta, Secretary
Pennsylvania Public Utility Commission
400 North Street
Harrisburg, PA 17120

RE: Application of Comcast Cable Communications Management, LLC, for Approval of the Installation of an Underground Communication Facility where Edgewood Road Crosses At-Grade with tracks of SEPTA Railroad. Located in Morrisville, Lower Makefield Township, Bucks County, PA; Docket No. A-2021-3024564.

Dear Secretary Chiavetta:

The enclosed Application of Comcast Communications Management, LLC, for the approval of the installation of an underground communication facility where Edgewood Road crosses at-grade with tracks of SEPTA railroad in Morrisville, Lower Makefield Township, Bucks County, PA, was approved by the PAPUC on March 7, 2023. The original completion date was slated for December 31, 2024. As this work is not yet complete, this letter is to request extension of the PAPUC's approval until December 31, 2026. Copies of this extension request have been served in accordance with the attached Certificate of Service.

Very truly yours,

Tabatha Smith
Tabatha Smith

Enclosure

Cc: Copy of Original Application Packet
Copy of PAPUC Secretarial Approval Letter

Tabatha Smith
Engineering Coordinator

(717) 408 – 9112
tabatha@americomm-llc.com

September 21, 2023

VIA ELECTRONIC FILING

Rosemary Chiavetta, Secretary
Pennsylvania Public Utility Commission
400 North Street
Harrisburg, PA 17120

RE: Application of Comcast Cable Communications Management, LLC, for Approval of the Installation of an Underground Communication Facility where Edgewood Road Crosses At-Grade with tracks of SEPTA Railroad. Located in Morrisville, Lower Makefield Township, Bucks County, PA; Docket No. A-2021-3024564.

Dear Secretary Chiavetta:

Enclosed please find the revised Application of Comcast Communications Management, LLC, for the approval of the installation of an underground communication facility where Edgewood Road crosses at-grade with tracks of SEPTA Railroad. Due to unforeseen delays in the project timeline, the project is now proposed to be completed by December 31, 2023. We ask for approval from the PAPUC for the extension of your approval of this project until December 31, 2023. Copies of the revised application have been served in accordance with the attached Certificate of Service.

Very truly yours,

Tabatha Smith

Tabatha Smith

Enclosure

Cc: Revised Application, Exhibit A, Verification, Certificate of Service
Engineered Utility Plan Set and Traffic Control Design

**BEFORE
THE PENNSYLVANIA PUBLIC UTILITIES COMMISSION**

RE: Application of Comcast Cable Communications Management, LLC, for Approval of the Installation of an Underground Communication Facility where Edgewood Road Crosses At-Grade with tracks of SEPTA Railroad. Located in Morrisville, Lower Makefield Township, Bucks County, PA. : Docket No. A-2021-3024564
: Comcast No. JB000500854
:
:
:
:
:

To the Pennsylvania Public Utility Commission:

Comcast Cable Communications Management, LLC (“Comcast Cable” or “Applicant”), requests that the Pennsylvania Public Utility Commission (“Commission”) approve Comcast Cable’s Application for a rail crossing pursuant to Section 2702(a) of the Pennsylvania Public Utility Code, 66 Pa.C.S. § 2702(a). In support thereof, Comcast Cable submits as follows:

1. The name and address of Applicant:

Comcast Cable Communications Management, LLC
1701 John F Kennedy Boulevard
Philadelphia, PA 19103

2. The name and address of Applicant’s attorney:

Comcast Cable Communications Management, LLC
1701 John F Kennedy Boulevard
Philadelphia, PA 19103
ATTN: General Counsel
Legal_Notices@comcast.com

3. Comcast Cable is a video, internet, and phone service provider in the Commonwealth of Pennsylvania. As such, Comcast Cable has the right to install and maintain its facilities at railroad crossings to provide reliable service to its customers in the Commonwealth of Pennsylvania.

4. The proposed installation will be a new 6” steel casing pipe conduit which will hold a 4” HDPE conduit holding a 3” Maxcell 3-cell innerduct. The 3-cell innerduct will hold communication wirelines belonging to Comcast Cable. The installation will be located on Edgewood Road, Morrisville, Lower Makefield Township, Bucks County, at the roads’ crossing of the railroad facilities of the Southeastern Pennsylvania Transportation Authority located between existing utility pole No. 53381 and existing utility pole No. 53380 as shown in Exhibit A. Railroad facilities will not be disturbed during construction of Comcast Cable’s proposed underground conduit. Construction of this facility is anticipated to begin as soon as approval is obtained. Construction will take approximately one (1) day to complete. Exhibit A depicts a proposed traffic control plan to be used for the duration of this construction.

5. The cost of the construction of the underground conduit is approximately one thousand dollars (\$1000.00). Comcast Cable will bear the cost of this construction. Comcast Cable will be responsible for installing, maintaining, and inspecting the facilities.

6. The parties that may be affected by the proposed facilities are as follows: the Pennsylvania Department of Transportation, Bucks County, Morrisville Borough, Lower Makefield Township, SEPTA, CSX Transportation, and PECO-An Exelon Company. The Applicant has served a copy of this Application upon the parties referenced, as shown on the attached Certificate of Service.

7. The installation of the new facility will be used to boost and extend Comcast Cable's service in the immediate and surrounding area.

WHEREFORE, Comcast Cable Communications Management, LLC, requests that the Pennsylvania Public Utility Commission approve the rail crossing described herein on or before October 9, 2023.

Respectfully submitted,

Dated: September 21, 2023

By: Tabatha Smith

Tabatha Smith, Engineering Coordinator
Americomm LLC, Business Partner of Comcast Cable
21 State Avenue, Suite 1
Carlisle, PA 17013
(717) 408 – 9112
tabatha@americomm-llc.com

**General Application 11-A
Channelizing Device Details**

Short-Term Devices Cones		
<p>Orange Retroreflective Sheeting (Typ.)</p> <p>White Retroreflective Sheeting (Typ.)</p> <p>6 1/2"</p> <p>6"</p> <p>6"</p> <p>6"</p> <p>6"</p> <p>42"</p>	<p>3" to 4"</p> <p>2"</p> <p>6"</p> <p>4"</p> <p>28" Min to 36" Max</p>	<p>3" to 4"</p> <p>6"</p> <p>18"</p>
<p>Figure 11-1 Tall Cone</p>	<p>Figure 11-2 Standard/Incident Management Cone</p>	<p>Figure 11-3 Pavement Marking Protection Cone</p>

Long-Term Devices Drums, Vertical Panels, Tubular Markers, and Barricades		
<p>18" Min.</p> <p>6"</p> <p>6"</p> <p>6"</p> <p>6"</p> <p>36" Min.</p>	<p>8" to 12"</p> <p>8" to 12"</p> <p>36" Min.</p> <p>24" Min.</p>	<p>2"</p> <p>3"</p> <p>3"</p> <p>2" to 6"</p> <p>28" Min.</p> <p>2"</p> <p>3"</p> <p>18" to 28"</p>
<p>Figure 11-4 Drum</p>	<p>Figure 11-5 Vertical Panel</p>	<p>Figure 11-6 Tubular Marker</p>
<p>6" to 8" (Typ.)</p> <p>8" or 12"</p> <p>36" Min.</p> <p>24" Min.</p>	<p>8" or 12"</p> <p>36" Min.</p> <p>24" Min.</p>	
<p>Figure 11-7 Type I Barricade</p>	<p>Figure 11-8 Type II Barricade</p>	
<p>8" or 12"</p> <p>60" Min.</p> <p>20" (Typ.)</p> <p>48" Min.</p>	<p>36" Min.</p> <p>12"</p> <p>8" or 12"</p> <p>24" Min.</p>	
<p>Figure 11-9 Type III Barricade</p>	<p>Figure 11-10 Direction Indicator Barricade</p>	



Yodock® 2001

LONGITUDINAL CHANNELIZING DEVICE



MASH



Yodock® 2001

The Yodock® 2001 Barricade is a plastic, water-filled Longitudinal Channelizing Device (LCD) used for traffic and pedestrian channelization, road and street closures, or perimeter fencing for vertical construction. When deployed as an LCD, the units are attached end-to-end using a plastic coupler.

Additional application specific accessories are also available for the Yodock® 2001 Barricade.

APPLICATIONS

- Temporary Work Zones
- Temporary Sign Support
- Perimeter Fencing
- Airport Construction & Maintenance
- Parking Facilities
- Municipal & Public Utilities
- Security Checkpoints
- Events & Crowd Control

FEATURES

- Lightweight system enables convenient positioning by hand.
- Can be accessorized for longitudinal barrier, perimeter fencing, road closure, and temporary sign support applications.
- Stackable for more efficient transportation and storage.
- Made of Low Density Polyethylene (LDPE).
- Convenient forklift access for maneuverability.
- Available in custom colors.

FHWA ELIGIBILITY

MASH

- Longitudinal Channelizing Device (LCD); Test Level 3

NCHRP 350

- Longitudinal Channelizing Device (LCD)
- Work Zone Barricade
- Temporary Sign Support
- Longitudinal Barrier (When used with Steel Rail Kit)

- 1 Interlocking Coupler
- 2 Light Box Recess
- 3 Fill Hole
- 4 Forklift Access
- 5 Drain Hole
- 6 Ground Mounting Ports

DISTRIBUTED BY

SPECIFICATIONS

- 6' Length
- 24" Width
- 46" Height
- Empty Weight: 130 lbs.

MASH

- Ballast Capacity: 75 gal.
- Ballasted Weight: 750 lbs.

NCHRP 350

- Ballast Capacity: 180 gal.
- Ballasted Weight: 1,500 lbs.

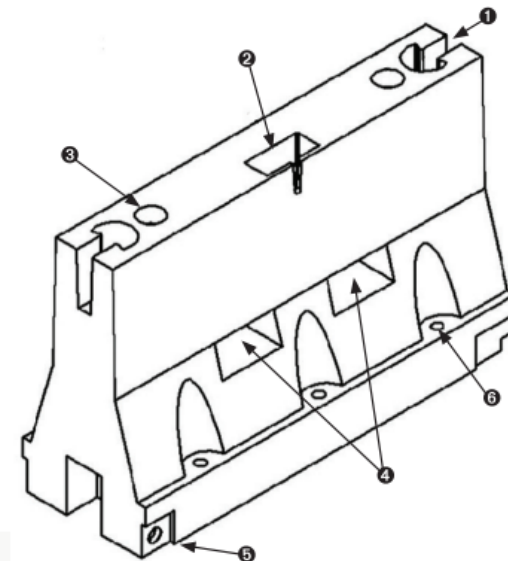

**BEFORE
THE PENNSYLVANIA PUBLIC UTILITIES COMMISSION**

RE: Application of Comcast Cable Communications Management, LLC, for Approval of the Installation of an Underground Communication Facility where Edgewood Road Crosses At-Grade with tracks of SEPTA Railroad. Located in Morrisville, Lower Makefield Township, Bucks County, PA. : Docket No. A-2021-3024564
: Comcast No. JB000500854
:
:
:
:
:

CERTIFICATE OF SERVICE

I hereby certify that I have this day served a true copy of the foregoing document upon the entities listed below in accordance with the requirements of 52 Pa. Code §1.54 (relating to service):

Pennsylvania Department of Transportation
ROW & Utility Division, Bureau of Design
P.O. Box 3362
Harrisburg, PA 17105-3362
danleonard@pa.gov

PECO – An Exelon Company
2301 Market Street, Suite N3-3
Philadelphia, PA 19103
Diana.gaiser@exeloncorp.com

Pennsylvania Department of Transportation
Office of Chief Counsel
P.O. Box 8212
Harrisburg, PA 17105-8212
kcummings@pa.gov

Comcast Cable Communications Management, LLC
Attn: Americomm LLC
21 State Avenue, Suite 1
Carlisle, PA 17013
tabatha@americomm-llc.com

Bucks County Planning Commission
1260 Almshouse Road
Doylestown, PA 18901
Planningcommission@buckscounty.org

Morrisville Borough
35 Union Street
Morrisville, PA 19067
info@morrisvillepagov.com

Southeastern Pennsylvania Transportation Authority
1234 Market Street - 13th Floor
Philadelphia, PA 19107
PASABERE@SEPTA.org
youssef@SEPTA.org

Dated: September 21, 2023

By: *Tabatha Smith*

Tabatha Smith

**BEFORE
THE PENNSYLVANIA PUBLIC UTILITIES COMMISSION**

RE: Application of Comcast Cable Communications Management, LLC, for Approval of the Installation of an Underground Communication Facility where Edgewood Road Crosses At-Grade with tracks of SEPTA Railroad. Located in Morrisville, Lower Makefield Township, Bucks County, PA.	:	Docket No. A-2021-3024564
	:	Comcast No. JB000500854
	:	
	:	
	:	
	:	

VERIFICATION

I, Tabatha Smith, Engineering Coordinator for Americomm LLC, a Business Partner of Comcast Cable, hereby state that the facts set forth in the Application of Comcast Cable Communications Management, LLC, are true and correct to the best of my knowledge, information, and belief. The statements herein are made subject to the penalties of 18 Pa.C.S. § 4904 relating to the unsworn falsification to authorities.

Dated: September 21, 2023

By: Tabatha Smith

Tabatha Smith, Engineering Coordinator
Americomm LLC, Business Partner of Comcast Cable
21 State Avenue, Suite 1
Carlisle, PA 17013
(717) 408 – 9112
tabatha@americomm-llc.com



COMMONWEALTH OF PENNSYLVANIA
PENNSYLVANIA PUBLIC UTILITY COMMISSION
COMMONWEALTH KEYSTONE BUILDING
400 NORTH STREET
HARRISBURG, PENNSYLVANIA 17120

IN REPLY PLEASE
REFER TO OUR FILE

March 7, 2023

A-2021-3024564

Via Eservice and Email Only
TO ALL PARTIES OF RECORD

Application of Comcast Cable Communications Management, LLC for approval of the installation of a communication facility where (DOT# 589 737 B) Edgewood Road crosses, at grade, the tracks of Southeastern Pennsylvania Transportation Authority (SEPTA) in Lower Makefield Township, Bucks County.

To Whom It May Concern:

By application filed with the Commission on March 12, 2021, and the revised application filed with the Commission March 18, 2022, Comcast Cable Communications Management, LLC seeks Commission approval to alter the public crossing (DOT# 589 737 B) by the installation of an underground communication facility placed between utility riser poles on the north side of the railroad crossing where Edgewood Road crosses, at grade, the tracks of Southeastern Pennsylvania Transportation Authority (SEPTA) in Lower Makefield Township, Bucks County.

The new line will be a 2-inch HDPE pipe which will be installed within an existing 4-inch case pipe conduit in the joint right-of-way of Edgewood Road and Southeastern Pennsylvania Transportation Authority (SEPTA). The existing 4-inch casing will provide a minimum cover depth of 5.5 feet from base of rail to the proposed gas line.

The Commission hereby establishes its jurisdictional limits at the subject crossing as the area within the confines of the railroad right-of-way and the highway right-of-way.

In its application, Comcast Cable Communications Management, LLC states that the proposed installation is necessary to provide adequate, efficient, and reasonable communication facilities to its customers. Comcast Cable Communications Management, LLC will be directed to perform the necessary installation, provide for maintenance and protection of highway and pedestrian traffic during installation and accept future maintenance responsibility for the new line, at its sole cost and expense. The cost of the project at the subject crossing is anticipated to be approximately \$1,000.

All work is to be performed in accordance with the drawing plans attached to the application as "Exhibit A".

Comcast Cable Communications Management, LLC has served a copy of the application and installation plan to all parties in interest. All parties in interest were queried by letter dated April 26, 2021, as to any objection to the subject application. None of the parties have responded with any objection to the subject application or plans.

The Commission has exclusive jurisdiction in crossing alterations and is the final arbiter of any fees associated with a crossing application. Any conditions, including fees associated with a crossing application, must be approved by the Commission.

Upon full consideration of the matters involved, we find that a hearing is not necessary and that a Secretarial Letter may be issued approving the application.

The Commission issues this Secretarial Letter in accordance with Section 2702 of the Public Utility Code and finds that the alteration of the crossing is necessary and proper for the service, accommodation, convenience, or safety of the public.

The application of Comcast Cable Communications Management, LLC is approved as herein directed:

1. The caption of the subject proceeding is hereby revised as shown herein.
2. The crossing where (DOT# 589 737 B) Edgewood Road crosses, at grade, the tracks of Southeastern Pennsylvania Transportation Authority (SEPTA) in Lower Makefield Township, Bucks County, be altered generally in accordance with the installation sketch plan entitled: "EXHIBIT A"; which plan is made part hereof and is hereby approved except insofar as it may relate to the division of work, deletion of work, or the allocation of costs and expenses incident to the installation of the project.
3. Comcast Cable Communications Management, LLC, at its sole cost and expense, furnish all material and perform all work necessary to alter the crossing by the installation of a communication facility within the joint right-of-way of the highway where Edgewood Road crosses, at grade, the tracks of Southeastern Pennsylvania Transportation Authority (SEPTA), all in accordance with the approved plan and this Secretarial Letter.
4. Comcast Cable Communications Management, LLC, at its sole cost and expense, furnish all material and perform all work necessary to establish and maintain any detours or traffic controls that may be required to properly and safely accommodate highway and pedestrian traffic during the time the crossing is being altered.
5. Any relocation of, changes in and/or removal of any adjacent structures, equipment or other facilities of any non-carrier public utility, other than Comcast Cable Communications Management, LLC, which may be required as incidental to the alteration of the crossing, be made by said public utility at its initial cost, and in such a manner as will not interfere with the alteration of the crossing; and such relocated or altered facilities thereafter be maintained by said public utility, at its sole cost and expense.

6. Southeastern Pennsylvania Transportation Authority (SEPTA), at the sole cost and expense of Comcast Cable Communications Management, LLC, furnish all material and perform all work relating to its facilities which may be required as incidental to the performance of the proposed work and furnish any watchmen, flagmen, inspectors and/or engineering services that may be deemed necessary to protect the railroad's operations or facilities during the time the facilities are being installed.

7. Comcast Cable Communications Management, LLC, at its sole cost and expense, furnish all material and perform all work necessary to complete the remainder of the project, and any other ancillary features of the project, generally in accordance with the approved plans and this Secretarial Letter.

8. The alteration of the crossing be completed on or before December 31, 2024, and that on or before said date Comcast Cable Communications Management, LLC, report in writing the date of actual completion of the work to this Commission and certify to the parties of record and this Commission that the work has been satisfactorily completed in accordance with the approved plans and this Secretarial Letter.

9. Comcast Cable Communications Management, LLC, at its sole cost and expense, pay all compensation for damages, if any, due to owners of property taken, injured, or destroyed by reason of the alteration of the crossing in accordance with this Secretarial Letter.

10. All parties involved herein cooperate fully with each other so that during the time the work is being performed, vehicular, pedestrian and railroad traffic will not be endangered or unnecessarily inconvenienced, and so that the requirements of each of the parties will be provided for and accommodated insofar as possible.

11. Comcast Cable Communications Management, LLC cooperate with the non-carrier utilities involved, so that during the alteration of the involved crossing, the facilities of the non-carrier utilities will not be endangered or unnecessarily interrupted.

12. Comcast Cable Communications Management, LLC, at least seven (7) days prior to the start of work, notify all parties in interest of the actual date on which work will begin.

13. Upon completion of the alteration of the crossing, Comcast Cable Communications Management, LLC, at its sole cost and expense, furnish all material and perform all work necessary thereafter to maintain the new line and any ancillary facilities installed in accordance with the approved plans and this Secretarial Letter.

14. Upon completion of the alteration of the crossing, Southeastern Pennsylvania Transportation Authority (SEPTA), at their sole cost and expense, furnish all material and perform all work necessary thereafter to maintain its railroad facilities at the subject crossing, including warning devices and all appurtenant equipment, and maintain at all times in a smooth and satisfactory condition the crossing surface located between the rails and for a distance of twenty-four (24) inches beyond the outermost rails and the area in between the tracks, all in accordance with Part 8 of the Manual on Uniform Traffic Control Devices and this Secretarial Letter, and provide Lower Makefield Township at least ten (10) business days advance notice when performing any work that may affect their facilities, as directed by this paragraph.

15. Upon completion of the alteration of the subject crossing, Lower Makefield Township, at its sole cost and expense, furnish all material and do all work necessary thereafter to maintain the highway approach roadway of the subject crossing to points twenty-four (24) inches beyond each outside rail and in addition, maintain the grade crossing advance warning signs, stop lines and pavement markings, if required, all in accordance with Part 8 of the Manual on Uniform Traffic Control Devices and this Secretarial Letter, and provide the Southeastern Pennsylvania Transportation Authority (SEPTA), at least ten (10) business days advance notice when performing any work that may affect their facilities as directed by this paragraph.

16. Upon completion of the work herein directed, and upon written request from any party of record, this proceeding be scheduled for a hearing at a time and place to be determined by the Commission, for the purpose of taking testimony upon the final allocation of any remaining costs incurred by the non-carrier utility companies and other matters relevant to this proceeding.

The Parties are reminded that failure to comply with this or any Order or Secretarial Letter in this proceeding may result in an enforcement action seeking civil penalties and/or other sanctions pursuant to 66 Pa. C.S. § 3301.

The Commission has waived certain regulatory service provisions as directed by the Commission's Order at M-2021-3028321. Currently, while the Commission's physical facilities are open for business, some of the operational restraints occasioned by the pandemic remain. It is evident that the pandemic and its changing nature require certain procedural flexibility for the public, the regulated community, and the Commission. Toward this end, the Commission will continue to permit electronic service by the Commission on all parties, regardless of whether a particular party has agreed to electronic service. An exception to this general waiver is where the Public Utility Code requires service by specified means, e.g., Section 702. Additionally, service on Commission staff in proceedings pending before it, whether staff is a party or otherwise, shall be exclusively electronic unless the parties agree otherwise. Filings must be submitted by efilings with the Secretary of the Commission by opening an efilings account through the Commission's website and accepting eservice at <https://www.puc.pa.gov/filing-resources/efiling/>. If your filing contains confidential material, you are required to file by overnight delivery to ensure the timely filing of your submission.

If you are dissatisfied with the resolution of this matter, you may, as set forth in 52 Pa. Code §§ 1.31 and 5.44, file a Petition for Reconsideration from Staff Action (Petition) with the Commission within twenty (20) days of the date of this letter. The Petition shall be submitted by e-filing said petition within twenty (20) days, or if no timely request is made, the action will be deemed to be a final action of the Commission.

The Petition MUST include: (1) a written statement (divided into numbered paragraphs) outlining the reasons for the request; (2) the case docket number (it is provided for you at the top right-hand corner of this letter); (3) the party on whose behalf the petition is made; (4) a Certificate of Service on the other parties of record; and (5) a Verification with original signature in accordance with 52 Pa. Code § 1.36.

Very truly yours,

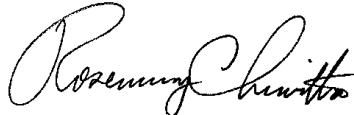
A handwritten signature in cursive script, appearing to read "Rosemary Chiavetta".

Rosemary Chiavetta
Secretary