

-----  
Bartholomew Lawrence,  
v.  
PECO Energy Company

| Docket No.: C-2024-3050908

|  
Initial Call-In  
Telephonic Hearing  
|  
-----

Pages 1 - 82

Judge's Chambers  
State Office Building  
801 Market Street  
Philadelphia, PA

September 30, 2025

Commencing at 1:01

INDEX TO EXHIBITS

Docket No. C-2024-3050908

Hearing Date: September 30, 2025

<u>NUMBER</u>	<u>FOR IDENTIFICATION</u>	<u>IN EVIDENCE</u>
PECO Exhibit 1	43	77
Noise Report		

PECO Exhibit 2	60	77
IEEE Standards		
PECO Exhibit 3	63	77
Material Specification		
PECO Exhibit 4	64	77
Photographs		
PECO Exhibit 5	38	77
Photographs		
Complainant's 1	76	77
Slideshow Presentation		



Direct Dial: 267-533-1830  
khadijah.scott@exeloncorp.com

September 24, 2025

**VIA E-MAIL**

Honorable Marta Guhl, ALJ  
Pennsylvania Public Utility Commission  
801 Market Street, 4<sup>th</sup> Floor, STE 4063  
Philadelphia, PA 19107

**RE: Bartholomew Lawrence v. PECO Energy Company**  
**Docket No. C-2024-3050908**  
**Date of Hearing: September 30, 2025 @ 1:00PM**

Dear Judge Guhl:

Enclosed please find a copy of PECO Energy Company's Exhibits 1 through 5, which it intends to use in the above referenced hearing. By copy of this letter, I am sending a copy of same to the Complainant.

Please call my direct dial number if you have any questions regarding this case.

Respectfully submitted,

A handwritten signature in blue ink that reads "Khadijah Scott". The signature is written in a cursive, flowing style.

Khadijah Scott

KS/ld  
Enclosure

cc: Bartholomew Lawrence (via email)

# **EXHIBIT 1**

## 446 Shurs Lane Noise Report

dB Levels measured with: REED R8080 Data Logging Sound Level Meter

Certification: IEC 61672-1 Class 2

Calibrated with: REED R8090 Sound Level Calibrator

Complies with: IEC 942 Class 2

Two Measurements were taken at between 2:30am-3:09am and 12:30pm-1:03pm at each of the three locations Shown below.

Between the hours of the 2-3am test there was a cop car idling in the parking lot, leading to a slightly increased overall average decibel.

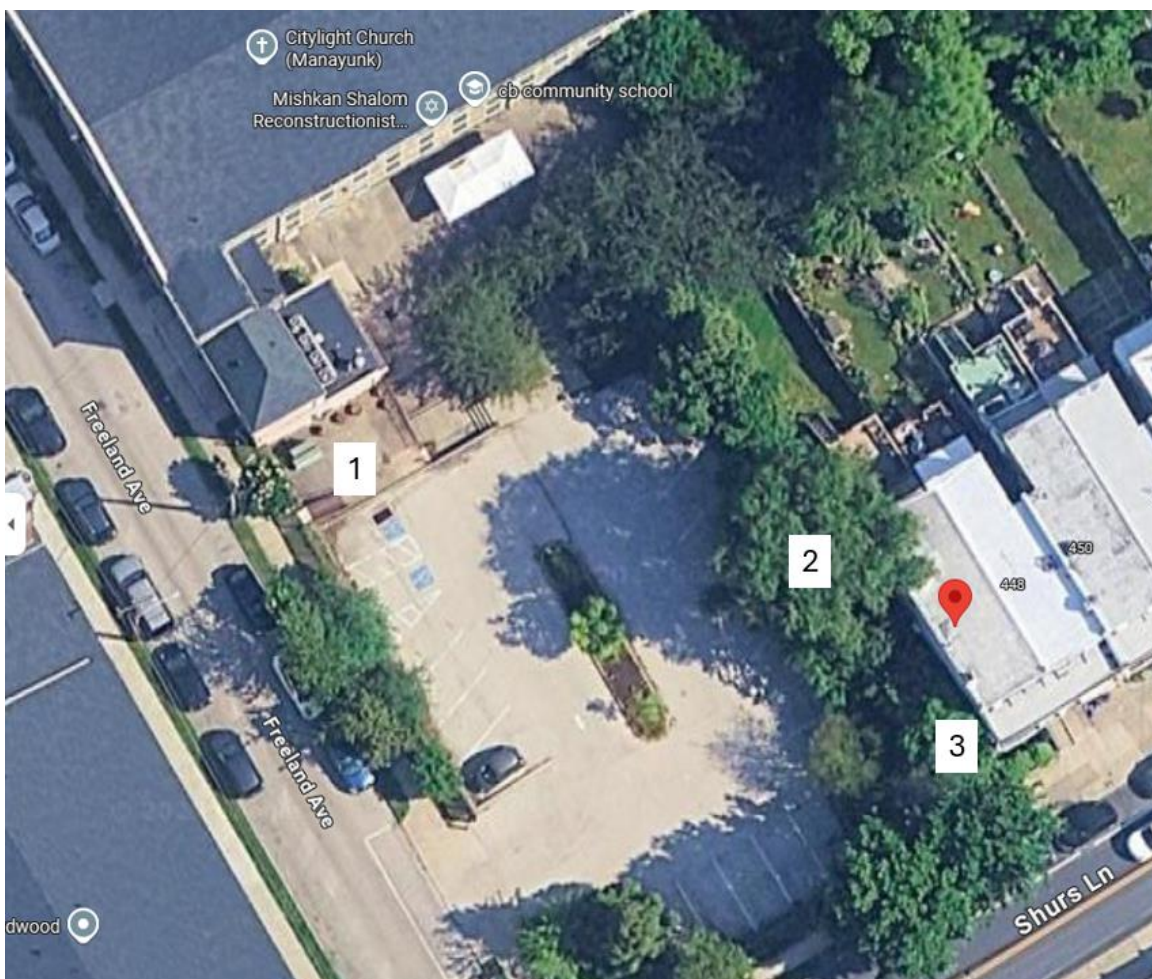

Location 1 Data:

Sound Graph 1

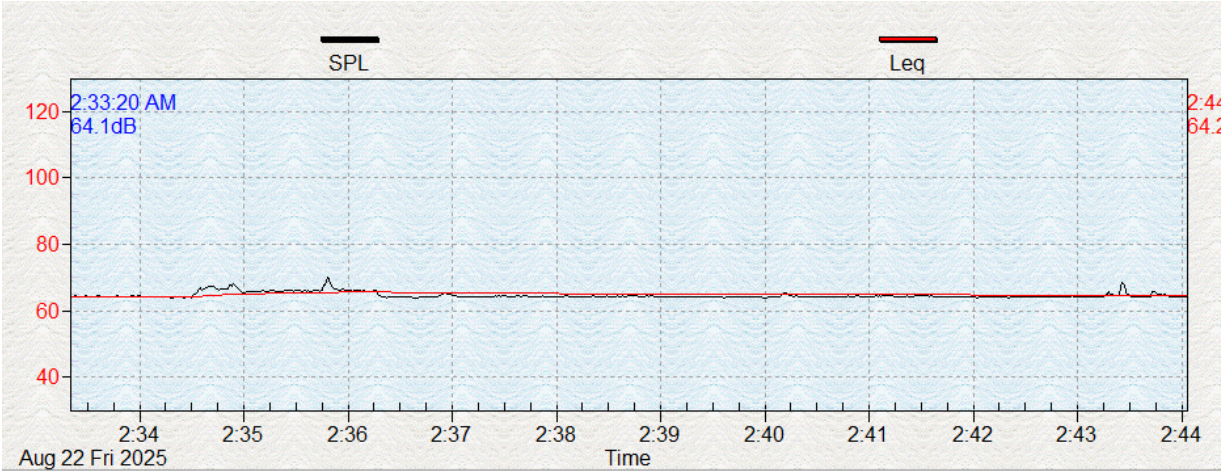

Sound Graph 2

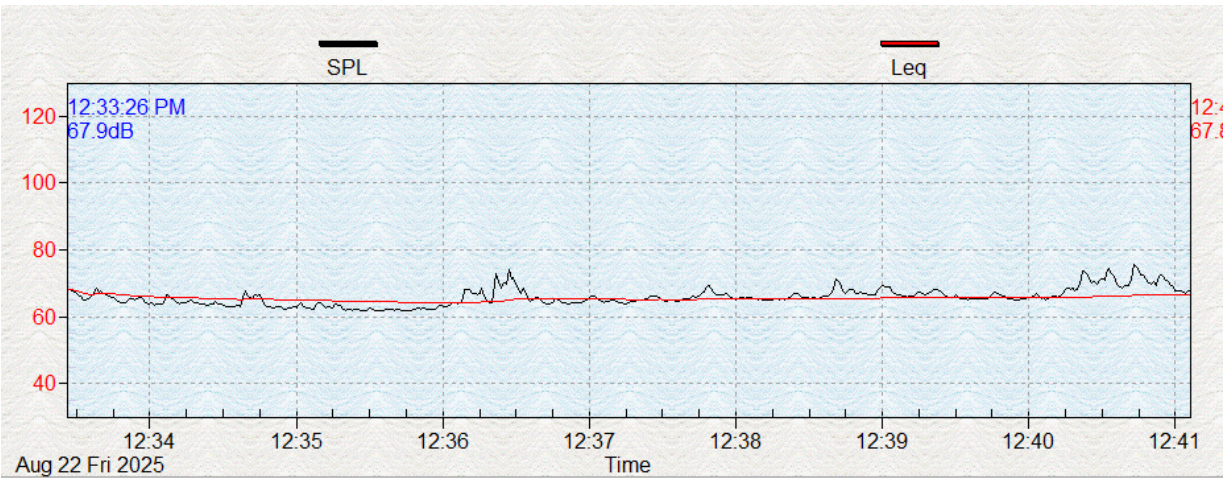
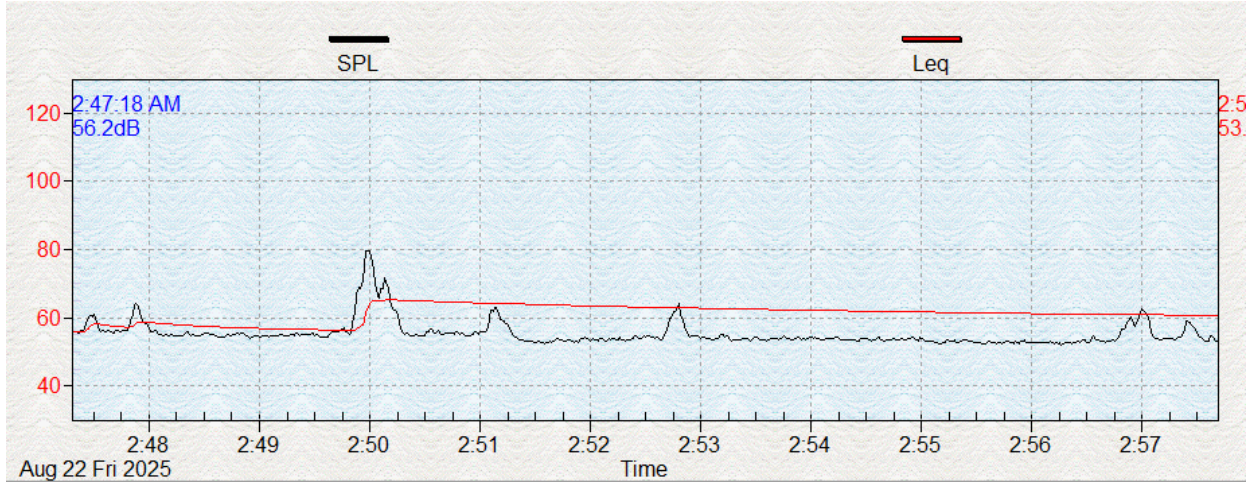

Table for Sound Graph 1	Table for Sound Graph 2
Start Time:8/22/2025 2:33:20 AM	Start Time:8/22/2025 12:33:26 PM
Sampling Rate:1.0	Sampling Rate:1.0
DataNo:644	DataNo:461
Avg.:64.6	Avg.:65.8
Maximum:70.3@8/22/2025 2:35:48 AM	Maximum:75.5@8/22/2025 12:40:43 PM
Minimum:63.8@8/22/2025 2:34:18 AM	Minimum:61.7@8/22/2025 12:35:35 PM
Cursor A:64.1@8/22/2025 2:33:20 AM	Cursor A:67.9@8/22/2025 12:33:26 PM
Cursor B:64.2@8/22/2025 2:44:03 AM	Cursor B:67.8@8/22/2025 12:41:06 PM

Location 2 Data:

Sound Graph 3



Sound Graph 4

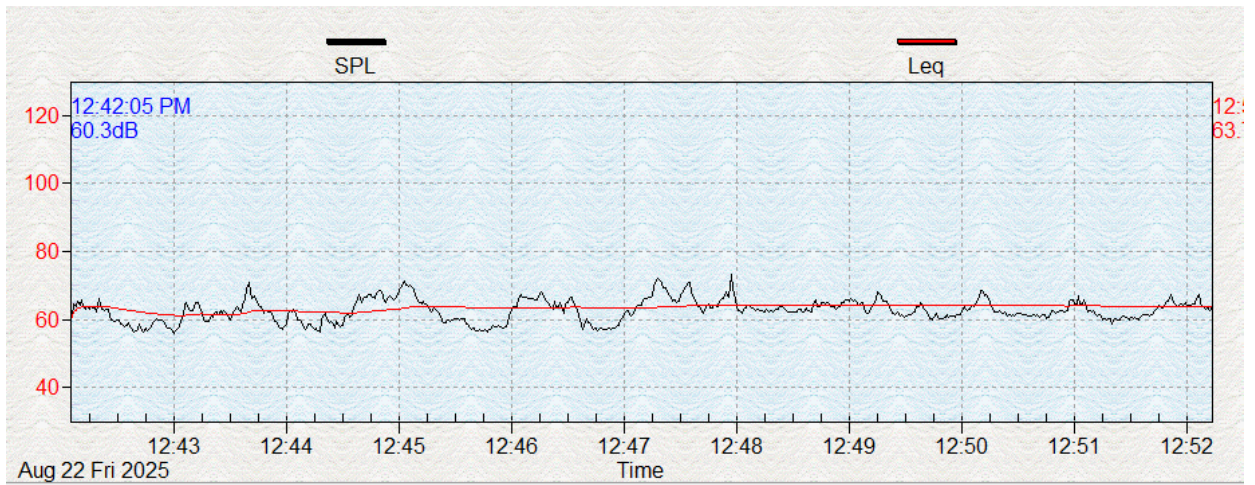
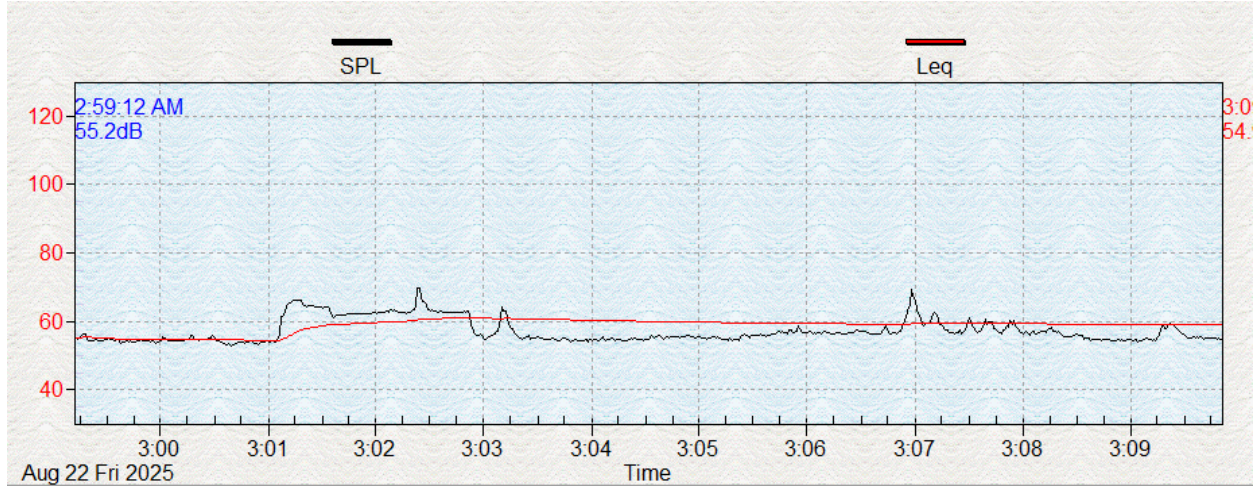

Table for Sound Graph 3	Table for Sound Graph 4
Start Time:8/22/2025 2:47:18 AM	Start Time:8/22/2025 12:42:05 PM
Sampling Rate:1.0	Sampling Rate:1.0
DataNo:624	DataNo:609
Avg.:55.3	Avg.:62.6
Maximum:79.8@8/22/2025 2:49:59 AM	Maximum:73.1@8/22/2025 12:47:57 PM
Minimum:52.1@8/22/2025 2:56:16 AM	Minimum:56.0@8/22/2025 12:43:00 PM
Cursor A:56.2@8/22/2025 2:47:18 AM	Cursor A:60.3@8/22/2025 12:42:05 PM
Cursor B:53.2@8/22/2025 2:57:41 AM	Cursor B:63.7@8/22/2025 12:52:13 PM

Location 3 Data:

Sound Graph 5



Sound Graph 6

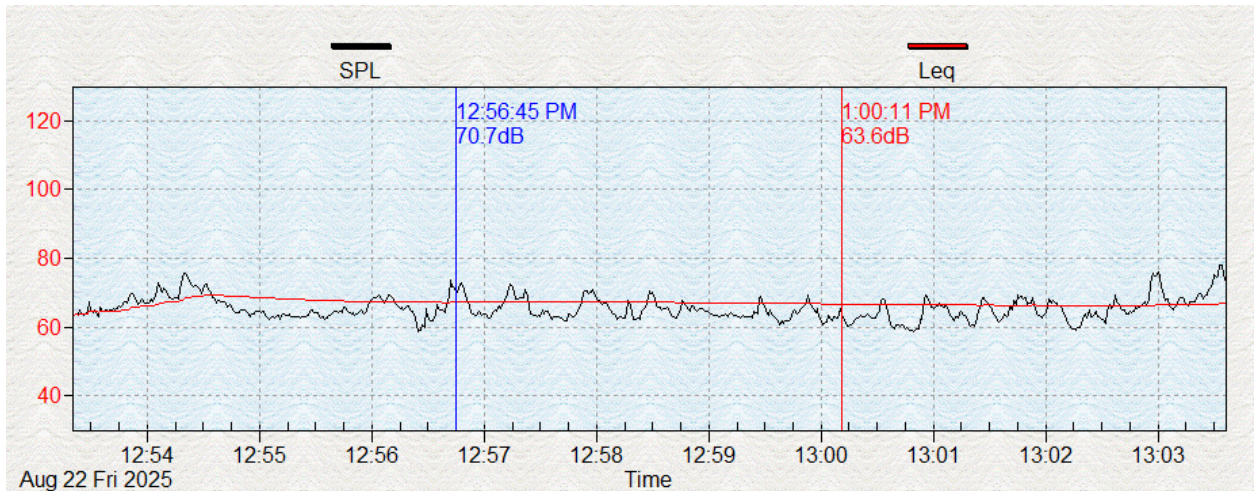

Table for Sound Graph 5	Table for Sound Graph 6
Start Time:8/22/2025 2:59:12 AM	Start Time:8/22/2025 12:53:20 PM
Sampling Rate:1.0	Sampling Rate:1.0
DataNo:640	DataNo:617
Avg.:57.1	Avg.:65.4
Maximum:69.6@8/22/2025 3:02:23 AM	Maximum:78.0@8/22/2025 1:03:34 PM
Minimum:52.9@8/22/2025 3:00:39 AM	Minimum:58.8@8/22/2025 12:56:25 PM
Cursor A:55.2@8/22/2025 2:59:12 AM	Cursor A:70.7@8/22/2025 12:56:45 PM
Cursor B:54.9@8/22/2025 3:09:51 AM	Cursor B:63.6@8/22/2025 1:00:11 PM

# **EXHIBIT 2**



# IEEE Standard for General Requirements for Liquid-Immersed Distribution, Power, and Regulating Transformers

IEEE Power and Energy Society

Developed by the  
Transformers Committee

**IEEE Std C57.12.00™-2021**  
(Revision of IEEE Std C57.12.00-2015)

**STANDARDS**

# **IEEE Standard for General Requirements for Liquid-Immersed Distribution, Power, and Regulating Transformers**

Developed by the

**Transformers Committee**  
of the  
**IEEE Power and Energy Society**

Approved 9 November 2021

**IEEE SA Standards Board**

**Abstract:** Electrical and mechanical requirements for liquid-immersed distribution and power transformers, and autotransformers and regulating transformers; single-phase and polyphase, with voltages of 601 V or higher in the highest voltage winding, are set forth. This standard is a basis for the establishment of performance, and limited electrical and mechanical interchangeability requirements of equipment are described; it is also a basis for assistance in the proper selection of such equipment. The requirements in this standard apply to all liquid-immersed distribution, power, and regulating transformers except the following: instrument transformers, step voltage and induction voltage regulators, arc furnace transformers, rectifier transformers, specialty transformers, grounding transformers, mobile transformers, and mine transformers.

**Keywords:** autotransformers, distribution transformers, electrical requirements, IEEE C57.12.00™, mechanical requirements, power transformers, regulating transformers

---

The Institute of Electrical and Electronics Engineers, Inc.  
3 Park Avenue, New York, NY 10016-5997, USA

Copyright © 2022 by The Institute of Electrical and Electronics Engineers, Inc.  
All rights reserved. Published 21 January 2022. Printed in the United States of America.

IEEE is a registered trademark in the U.S. Patent & Trademark Office, owned by The Institute of Electrical and Electronics Engineers, Incorporated.

PDF: ISBN 978-1-5044-8176-2 STD25089  
Print: ISBN 978-1-5044-8177-9 STDPD25089

*IEEE prohibits discrimination, harassment, and bullying.  
For more information, visit <https://www.ieee.org/about/corporate/governance/p9-26.html>.  
No part of this publication may be reproduced in any form, in an electronic retrieval system or otherwise, without the prior written permission of the publisher.*

## Important Notices and Disclaimers Concerning IEEE Standards Documents

IEEE Standards documents are made available for use subject to important notices and legal disclaimers. These notices and disclaimers, or a reference to this page (<https://standards.ieee.org/ipr/disclaimers.html>), appear in all standards and may be found under the heading “Important Notices and Disclaimers Concerning IEEE Standards Documents.”

## Notice and Disclaimer of Liability Concerning the Use of IEEE Standards Documents

IEEE Standards documents are developed within the IEEE Societies and the Standards Coordinating Committees of the IEEE Standards Association (IEEE SA) Standards Board. IEEE develops its standards through an accredited consensus development process, which brings together volunteers representing varied viewpoints and interests to achieve the final product. IEEE Standards are documents developed by volunteers with scientific, academic, and industry-based expertise in technical working groups. Volunteers are not necessarily members of IEEE or IEEE SA, and participate without compensation from IEEE. While IEEE administers the process and establishes rules to promote fairness in the consensus development process, IEEE does not independently evaluate, test, or verify the accuracy of any of the information or the soundness of any judgments contained in its standards.

IEEE does not warrant or represent the accuracy or completeness of the material contained in its standards, and expressly disclaims all warranties (express, implied and statutory) not included in this or any other document relating to the standard, including, but not limited to, the warranties of: merchantability; fitness for a particular purpose; non-infringement; and quality, accuracy, effectiveness, currency, or completeness of material. In addition, IEEE disclaims any and all conditions relating to results and workmanlike effort. In addition, IEEE does not warrant or represent that the use of the material contained in its standards is free from patent infringement. IEEE Standards documents are supplied “AS IS” and “WITH ALL FAULTS.”

Use of an IEEE standard is wholly voluntary. The existence of an IEEE Standard does not imply that there are no other ways to produce, test, measure, purchase, market, or provide other goods and services related to the scope of the IEEE standard. Furthermore, the viewpoint expressed at the time a standard is approved and issued is subject to change brought about through developments in the state of the art and comments received from users of the standard.

In publishing and making its standards available, IEEE is not suggesting or rendering professional or other services for, or on behalf of, any person or entity, nor is IEEE undertaking to perform any duty owed by any other person or entity to another. Any person utilizing any IEEE Standards document, should rely upon his or her own independent judgment in the exercise of reasonable care in any given circumstances or, as appropriate, seek the advice of a competent professional in determining the appropriateness of a given IEEE standard.

IN NO EVENT SHALL IEEE BE LIABLE FOR ANY DIRECT, INDIRECT, INCIDENTAL, SPECIAL, EXEMPLARY, OR CONSEQUENTIAL DAMAGES (INCLUDING, BUT NOT LIMITED TO: THE NEED TO PROCURE SUBSTITUTE GOODS OR SERVICES; LOSS OF USE, DATA, OR PROFITS; OR BUSINESS INTERRUPTION) HOWEVER CAUSED AND ON ANY THEORY OF LIABILITY, WHETHER IN CONTRACT, STRICT LIABILITY, OR TORT (INCLUDING NEGLIGENCE OR OTHERWISE) ARISING IN ANY WAY OUT OF THE PUBLICATION, USE OF, OR RELIANCE UPON ANY STANDARD, EVEN IF ADVISED OF THE POSSIBILITY OF SUCH DAMAGE AND REGARDLESS OF WHETHER SUCH DAMAGE WAS FORESEEABLE.

## Translations

The IEEE consensus development process involves the review of documents in English only. In the event that an IEEE standard is translated, only the English version published by IEEE is the approved IEEE standard.

## Official statements

A statement, written or oral, that is not processed in accordance with the IEEE SA Standards Board Operations Manual shall not be considered or inferred to be the official position of IEEE or any of its committees and shall not be considered to be, nor be relied upon as, a formal position of IEEE. At lectures, symposia, seminars, or educational courses, an individual presenting information on IEEE standards shall make it clear that the presenter's views should be considered the personal views of that individual rather than the formal position of IEEE, IEEE SA, the Standards Committee, or the Working Group.

## Comments on standards

Comments for revision of IEEE Standards documents are welcome from any interested party, regardless of membership affiliation with IEEE or IEEE SA. However, **IEEE does not provide interpretations, consulting information, or advice pertaining to IEEE Standards documents.**

Suggestions for changes in documents should be in the form of a proposed change of text, together with appropriate supporting comments. Since IEEE standards represent a consensus of concerned interests, it is important that any responses to comments and questions also receive the concurrence of a balance of interests. For this reason, IEEE and the members of its Societies and Standards Coordinating Committees are not able to provide an instant response to comments, or questions except in those cases where the matter has previously been addressed. For the same reason, IEEE does not respond to interpretation requests. Any person who would like to participate in evaluating comments or in revisions to an IEEE standard is welcome to join the relevant IEEE working group. You can indicate interest in a working group using the Interests tab in the Manage Profile & Interests area of the [IEEE SA myProject system](#). An IEEE Account is needed to access the application.

Comments on standards should be submitted using the [Contact Us](#) form.

## Laws and regulations

Users of IEEE Standards documents should consult all applicable laws and regulations. Compliance with the provisions of any IEEE Standards document does not constitute compliance to any applicable regulatory requirements. Implementers of the standard are responsible for observing or referring to the applicable regulatory requirements. IEEE does not, by the publication of its standards, intend to urge action that is not in compliance with applicable laws, and these documents may not be construed as doing so.

## Data privacy

Users of IEEE Standards documents should evaluate the standards for considerations of data privacy and data ownership in the context of assessing and using the standards in compliance with applicable laws and regulations.

## Copyrights

IEEE draft and approved standards are copyrighted by IEEE under US and international copyright laws. They are made available by IEEE and are adopted for a wide variety of both public and private uses. These include

both use, by reference, in laws and regulations, and use in private self-regulation, standardization, and the promotion of engineering practices and methods. By making these documents available for use and adoption by public authorities and private users, IEEE does not waive any rights in copyright to the documents.

## Photocopies

Subject to payment of the appropriate licensing fees, IEEE will grant users a limited, non-exclusive license to photocopy portions of any individual standard for company or organizational internal use or individual, non-commercial use only. To arrange for payment of licensing fees, please contact Copyright Clearance Center, Customer Service, 222 Rosewood Drive, Danvers, MA 01923 USA; +1 978 750 8400; <https://www.copyright.com/>. Permission to photocopy portions of any individual standard for educational classroom use can also be obtained through the Copyright Clearance Center.

## Updating of IEEE Standards documents

Users of IEEE Standards documents should be aware that these documents may be superseded at any time by the issuance of new editions or may be amended from time to time through the issuance of amendments, corrigenda, or errata. An official IEEE document at any point in time consists of the current edition of the document together with any amendments, corrigenda, or errata then in effect.

Every IEEE standard is subjected to review at least every 10 years. When a document is more than 10 years old and has not undergone a revision process, it is reasonable to conclude that its contents, although still of some value, do not wholly reflect the present state of the art. Users are cautioned to check to determine that they have the latest edition of any IEEE standard.

In order to determine whether a given document is the current edition and whether it has been amended through the issuance of amendments, corrigenda, or errata, visit [IEEE Xplore](#) or [contact IEEE](#). For more information about the IEEE SA or IEEE's standards development process, visit the IEEE SA Website.

## Errata

Errata, if any, for all IEEE standards can be accessed on the [IEEE SA Website](#). Search for standard number and year of approval to access the web page of the published standard. Errata links are located under the Additional Resources Details section. Errata are also available in [IEEE Xplore](#). Users are encouraged to periodically check for errata.

## Patents

IEEE Standards are developed in compliance with the [IEEE SA Patent Policy](#).

## IMPORTANT NOTICE

IEEE Standards do not guarantee or ensure safety, security, health, or environmental protection, or ensure against interference with or from other devices or networks. IEEE Standards development activities consider research and information presented to the standards development group in developing any safety recommendations. Other information about safety practices, changes in technology or technology implementation, or impact by peripheral systems also may be pertinent to safety considerations during implementation of the standard. Implementers and users of IEEE Standards documents are responsible for determining and complying with all appropriate safety, security, environmental, health, and interference protection practices and all applicable laws and regulations.

## Participants

At the time this IEEE standard was completed, the Continuous Revision of C57.12.00 Working Group had the following membership:

### Steven Snyder, *Chair*

Tauhid Ansari  
Stephen Antosz  
Eric Davis

Ramsis Girgis  
William Griesacker  
Philip Hopkinson  
Stephen Shull

Ajith Varghese  
Rogerio Verdolin  
David Walker

The following members of the individual Standards Association balloting group voted on this standard. Balloters may have voted for approval, disapproval, or abstention.

Samuel Aguirre  
Gregory Anderson  
Tauhid Haque Ansari  
Stephen Antosz  
I. Antweiler  
Javier Arteaga  
Donald Ayers  
Robert Ballard  
Peter Balma  
Radoslav Barac  
Gilles Bargone  
Thomas Barnes  
Paul Barnhart  
Christopher Baumgartner  
Barry Beaster  
Jeffrey Benach  
W. J. (Bill) Bergman  
Steven Bezner  
Wallace Binder  
Thomas Bishop  
Thomas Blackburn  
Daniel Blyndon  
William Bloethe  
W. Boettger  
Jeffrey Britton  
Darren Brown  
Steven Brown  
Koti Reddy Butukuri  
Thomas Callsen  
Paul Cardinal  
Richard Carter  
Michael Chirico  
Craig Colopy  
John Crouse  
Thomas Dausat  
Scott Digby  
Gary Donner  
Jeffrey Door  
Thomas Dunmore II  
Donald Dunn  
Jorge Fernandez Daher

Joseph Foldi  
Bruce Forsyth  
Carl Fredericks  
Fredric Friend  
Jose Gamboa  
Shubhankar Garg  
Saurabh Ghosh  
David Gilmer  
Ramsis Girgis  
Jalal Gohari  
James Graham  
William Griesacker  
Said Hachichi  
John Harley  
J. Harlow  
Roger Hayes  
Kyle Heiden  
Jeffrey Helzer  
Sergio Hernandez  
Werner Hoelzl  
Robert Hoerauf  
Gary Hoffman  
Philip Hopkinson  
John Houdek  
Mohammad, Iman  
Ramadan Issack  
Richard Jackson  
John John  
Laszlo Kadar  
John Kay  
Gael Kennedy  
Sheldon Kennedy  
Irfan Khan  
Gary King  
James Kinney  
Zan Kiparizoski  
William Knapek  
Boris Kogan  
Axel Kraemer  
Jim Kulchisky  
John Lackey

Chung-Yiu Lam  
Benjamin Lanz  
An Le  
Moonhee Lee  
Giancarlo Leone  
Aleksandr Levin  
Ting Li  
Weijun Li  
Mario Locarno  
Thomas Lundquist  
Tapan Manna  
Richard Marek  
J. Dennis Marlow  
Timothy Marrinan  
Lee Matthews  
James McBride  
Jeffrey McElray  
Mark McNally  
Susan McNelly  
Vinay Mehrotra  
Reza Mirza Hessabi  
Daniel Mulkey  
Jerry Murphy  
Ali Naderian Jahromi  
K. R. M. Nair  
Dennis Neitzel  
Arthur Neubauer  
James Niemira  
Joe Nims  
Sivaraman P.  
Lorraine Padden  
Dwight Parkinson  
Dhiru Patel  
Brian Penny  
Harry Pepe  
Mark Perkins  
Branimir Petosic  
Christopher Petrola  
Sylvain Plante  
Alvaro Portillo  
Bertrand Poulin

Tom Prevost  
Jarrod Prince  
Ion Radu  
Moises Ramos  
Scott Reed  
Clemens Reiss IV  
Jean-Christophe Riboud  
Pierre Riffon  
Bruce Rockwell  
Charles Rogers  
Oleg Roizman  
Rodrigo Ronchi  
Hakan Sahin  
Mahesh Sampat  
Jesus Sanchez-Rodriguez  
Dinesh Sankarakurup  
Daniel Sauer  
Roderick Sauls  
Bartien Sayogo  
Eric Schleismann  
Stephen Schroeder  
Devki Sharma  
Samuel Sharpless

Stephen Shull  
Hyeong Sim  
Jerry Smith  
Gary Smullin  
Steve Snyder  
Thomas Spitzer  
Kyle Stechschulte  
Brian Steinbrecher  
Shankar Subramany  
Humayun Tariq  
Ed TeNyenhuis  
David Tepen  
Juan Thierry  
Michael Thompson  
Eduardo Tolcachir  
Alan Traut  
James Van De Ligt  
Ajith Varghese  
Jason Varnell  
Joshua Verdell  
Rogerio Verdolin  
John Vergis  
Quintin Verzosa

Donald Voltz  
Loren Wagenaar  
Nick Walder  
David Walker  
David Wallace  
David Wallach  
Shelby Walters  
Joe Watson  
Eric Weatherbee  
Lee Welch  
Drew Welton  
Donald Wengerter  
Kenneth White  
Alan Wilks  
Terry Woodyard  
Baitun Yang  
Kipp Yule  
Nicholas Zagrodnik  
David Zech  
Shibao Zhang  
Peter Zhao  
Kris Zibert

When the IEEE SA Standards Board approved this standard on 9 November 2021, it had the following membership:

**Gary Hoffman, *Chair***  
**Jon Walter Rosdahl, *Vice Chair***  
**John D. Kulick, *Past Chair***  
**Konstantinos Karachalios, *Secretary***

Edward A. Addy  
Doug Edwards  
Ramy Ahmed Fathy  
J. Travis Griffith  
Thomas Koshy  
Joseph L. Koepfinger\*  
David J. Law

\*Member Emeritus

Howard Li  
Daozhuang Lin  
Kevin Lu  
Daleep C. Mohla  
Chenhui Niu  
Damir Novosel  
Annette Reilly  
Dorothy Stanley

Mehmet Ulema  
Lei Wang  
F. Keith Waters  
Karl Weber  
Sha Wei  
Howard Wolfman  
Daidi Zhong

## Introduction

This introduction is not part of IEEE Std C57.12.00-2021, IEEE Standard for General Requirements for Liquid-Immersed Distribution, Power, and Regulating Transformers.

Where applicable, editorial changes have been incorporated into this revision. Sentence structure and punctuation have been edited to improve clarity and conciseness. Also, editorial changes have been made to conform to the *2021 IEEE SA Standards Style Manual*.<sup>1</sup> Some changes have also been made to correct errors in previous revisions. When applicable, references to other standards have been updated.

A summary of the major changes is listed in sequential order, as follows:

- a) IEEE Std 1427™ added to Clause 2, Normative references.
- b) Clause 5.7.2, Angular displacement between voltages of windings for three-phase transformers, has been restructured for clarity.
- c) Note f to Table 6, Nameplate information, was revised to more clearly state which basic lightning impulse insulation levels (BIL) are to be shown on the nameplate.
- d) Figure 4 was revised to remove the metric M22 thread alternative because it is not interchangeable with the imperial thread 7/8 in-14, the prevalent usage in North America.
- e) Subclause 6.7.2.1, Grounding of wound cores, was added to emphasize proper core grounding for certain types of transformers utilizing wound cores. A corresponding note was added in Table 17 to specify a special partial discharge test to confirm the adequacy of the core grounding.
- f) Subclause 6.8, Minimum external clearances of transformer live parts, has been completely rewritten and a new Table 10 introduced.
- g) The equations and list of variables in 7.4 have been rearranged to improve clarity.
- h) Equation (14) and Equation (15), for calculating the temperature of windings during a short circuit in 7.4, have been revised due to an earlier metrification conversion error.
- i) An additional test requirement for measuring load loss at the minimum and maximum kVA has been added in Table 17.
- j) The note which describes audible sound level requirements in Table 17 has been moved to a new 8.2.5 for better clarity. Similarly, Annex C has been completely rewritten to incorporate no-load sound pressure levels from NEMA TR1, and to add reference sound pressure levels for load noise.
- k) Annex C, Audible sound pressure levels, has been changed to normative material.
- l) Annex D, Bibliography, has been updated.

Revisions of individual clauses (now modified) were prepared by separate groups within the Transformers Committee. Those clauses were balloted independently in the Working Groups, according to applicable rules and procedures of the Transformers Committee P&P Manual.

Suggestions for improvement resulting from use of this standard will be welcomed.

<sup>1</sup> Available at <https://development.standards.ieee.org/myproject/Public/mytools/draft/styleman.pdf>.

## Contents

1. Overview.....	11
1.1 Scope.....	11
1.2 Purpose .....	11
1.3 Word usage .....	12
2. Normative references .....	12
3. Definitions .....	13
4. Service conditions .....	13
4.1 Usual service conditions.....	13
4.2 Loading at other-than-rated conditions.....	15
4.3 Unusual service conditions.....	16
5. Rating data .....	17
5.1 Cooling classes of transformers.....	17
5.2 Frequency.....	19
5.3 Phases .....	19
5.4 Rated kilovoltamperes.....	20
5.5 Voltage ratings and taps .....	21
5.6 Connections.....	21
5.7 Polarity, angular displacement, and terminal marking .....	21
5.8 Impedance .....	22
5.9 Total losses .....	22
5.10 Insulation levels .....	22
5.11 Temperature rise and loading conditions.....	30
5.12 Nameplates.....	32
6. Construction.....	38
6.1 Bushings.....	38
6.2 Transformer accessories .....	38
6.3 Bushing current transformers .....	38
6.4 Thermometer wells .....	39
6.5 Tank pressure requirements.....	40
6.6 Liquid insulation system .....	40
6.7 Grounding .....	41
6.8 Minimum external clearances of transformer live parts .....	41
7. Short-circuit characteristics .....	45
7.1 Requirements .....	45
7.2 Components .....	51
7.3 Base kilovoltamperes .....	51
7.4 Calculation of winding temperature during a short circuit .....	53
8. Testing and calculations.....	54
8.1 General.....	54
8.2 Routine, design, and other tests for transformers .....	54
8.3 Additional routine tests on transformers with load tap changing or regulating transformers .....	58
8.4 Determination of transformer regulation.....	59
8.5 Determination of thermal duplicate temperature-rise data.....	59
8.6 Frequency conversion of transformer performance parameters (50/60 Hz) .....	59
8.7 Certified test data .....	60

9. Tolerances.....	61
9.1 Tolerances for ratio .....	61
9.2 Tolerances for impedance .....	62
9.3 Tolerances for losses.....	62
9.4 Accuracies required for measuring losses .....	62
10. Connection of transformers for shipment.....	63
Annex A (informative) Cooling class designations .....	64
Annex B (informative) Front-of-wave test levels .....	65
Annex C (normative) Audible sound pressure levels for no-load and load noise of liquid-immersed power and distribution transformers .....	67
Annex D (informative) Bibliography .....	70

# IEEE Standard for General Requirements for Liquid-Immersed Distribution, Power, and Regulating Transformers

## 1. Overview

### 1.1 Scope

This standard describes electrical and mechanical requirements of liquid-immersed distribution and power transformers, and autotransformers and regulating transformers, single-phase and polyphase, with voltages of 601 V or higher in the highest voltage winding.

This standard applies to all liquid-immersed distribution, power, and regulating transformers that do not belong to the following types of apparatus:

- a) Instrument transformers
- b) Step voltage and induction voltage regulators
- c) Arc furnace transformers
- d) Rectifier transformers
- e) Specialty transformers
- f) Grounding transformers
- g) Mobile transformers
- h) Mine transformers

### 1.2 Purpose

This standard is a basis for the establishment of performance and limited electrical and mechanical interchangeability requirements of the equipment are described. It is also a basis for assistance in the proper selection of such equipment.

### 1.3 Word usage

The word *shall* indicates mandatory requirements strictly to be followed in order to conform to the standard and from which no deviation is permitted (*shall* equals *is required to*).<sup>2, 3</sup>

The word *should* indicates that among several possibilities one is recommended as particularly suitable, without mentioning or excluding others; or that a certain course of action is preferred but not necessarily required (*should* equals *is recommended that*).

The word *may* is used to indicate a course of action permissible within the limits of the standard (*may* equals *is permitted to*).

The word *can* is used for statements of possibility and capability, whether material, physical, or causal (*can* equals *is able to*).

### 2. Normative references

The following referenced documents are indispensable for the application of this document (i.e., they must be understood and used, so each referenced document is cited in text and its relationship to this document is explained). For dated references, only the edition cited applies. For undated references, the latest edition of the referenced document (including any amendments or corrigenda) applies.

ANSI C84.1, American National Standard for Electric Power Systems and Equipment—Voltage Ratings (60 Hz).<sup>4</sup>

ASME Boiler and Pressure Vessel Code (BPVC).<sup>5</sup>

ASTM D92, Standard Test Methods for Flash and Fire Points by Cleveland Open Cup Tester.<sup>6</sup>

ASTM D1933, Standard Specification for Nitrogen Gas as an Electrical Insulating Material.

ASTM D2225, Standard Test Methods for Silicone Fluids Used for Electrical Insulation.

ASTM D3487, Standard Specification for Mineral Insulating Oil Used in Electrical Apparatus.

ASTM D5222, Standard Specification for High Fire-Point Mineral Electrical Insulating Oils.

ASTM D6871, Standard Specification for Natural (Vegetable Oil) Ester Fluids Used in Electrical Apparatus.

CGA V-1, Compressed Gas Cylinder Valve Outlet and Inlet Connections.<sup>7</sup>

IEEE Std 315<sup>TM</sup>, IEEE Standard Graphic Symbols for Electrical and Electronics Diagrams (Including Reference Designation Letters).<sup>8, 9</sup>

IEEE Std 315A<sup>TM</sup>, American National Standard/IEEE Standard Supplement to Graphic Symbols for Electrical and Electronics Diagrams (Supplement to IEEE Std 315-1975).

---

<sup>2</sup> The use of the word *must* is deprecated and cannot be used when stating mandatory requirements, *must* is used only to describe unavoidable situations.

<sup>3</sup> The use of *will* is deprecated and cannot be used when stating mandatory requirements, *will* is only used in statements of fact.

<sup>4</sup> ANSI publications are available from the American National Standards Institute (<http://www.ansi.org/>).

<sup>5</sup> ASME publications are available from the American Society of Mechanical Engineers (<http://www.asme.org/>).

<sup>6</sup> ASTM publications are available from the American Society for Testing and Materials (<http://www.astm.org/>).

<sup>7</sup> CGA publications are available at: <https://portal.cganet.com/Publication/index.aspx>.

<sup>8</sup> IEEE publications are available from The Institute of Electrical and Electronics Engineers (<http://standards.ieee.org/>).

<sup>9</sup> The IEEE standards or products referred to in this clause are trademarks of The Institute of Electrical and Electronics Engineers, Inc.

IEEE Std 469™, IEEE Recommended Practice for Voice-Frequency Electrical-Noise Tests of Distribution Transformers.

IEEE Std 1427™, IEEE Guide for Recommended Electrical Clearances and Insulation Levels in Air Insulated Electrical Power Substations.

IEEE Std C57.12.70™, IEEE Standard for Standard Terminal Markings and Connections for Distribution and Power Transformers.

IEEE Std C57.12.80™, IEEE Standard Terminology for Power and Distribution Transformers.

IEEE Std C57.12.90™, IEEE Standard Test Code for Liquid-Immersed Distribution, Power, and Regulating Transformers.

IEEE Std C57.19.01™, IEEE Standard for Performance Characteristics and Dimensions for Power Transformer and Reactor Bushings.

IEEE Std C57.19.04™, IEEE Standard for Performance Characteristics and Dimensions for High Current Power Transformer Bushings with Rated Continuous Current in Excess of 5000 A in Bus Enclosures.

IEEE Std C57.131™, IEEE Standard Requirements for Tap Changers.

### 3. Definitions

Standard transformer terminology available in IEEE Std C57.12.80 shall apply. The *IEEE Standards Dictionary Online* should be consulted for terms not defined in this clause.<sup>10</sup>

## 4. Service conditions

### 4.1 Usual service conditions

#### 4.1.1 General

Transformers conforming to this standard shall be suitable for operation at rated kVA under the following usual service conditions.

#### 4.1.2 Temperature

##### 4.1.2.1 Cooling air temperature limit

When air-cooled, the temperature of the cooling air (ambient temperature) shall not exceed 40 °C, and the average temperature of the cooling air for any 24 h period shall not exceed 30 °C.

##### 4.1.2.2 Liquid temperature limit

The top liquid temperature of the transformer (when operating) shall not be lower than –20 °C. Liquid temperatures below –20 °C are not considered as usual service conditions.

---

<sup>10</sup>*IEEE Standards Dictionary Online* is available at: <http://dictionary.ieee.org>. An IEEE Account is required for access to the dictionary, and one can be created at no charge on the dictionary sign-in page.

#### 4.1.2.3 Cooling water temperature limit

When water-cooled, the temperature of the cooling water (ambient temperature) shall not exceed 30 °C, and the average temperature of the cooling water for any 24 h period shall not exceed 25 °C. Minimum water temperature shall not be lower than 1 °C, unless the cooling water includes antifreeze, which is suitable for –20 °C operation.

#### 4.1.3 Altitude

The altitude shall not exceed 1000 m (3300 ft).

#### 4.1.4 Supply voltage

The supply-voltage wave shape shall be approximately sinusoidal. The phase voltages supplying a polyphase transformer shall be approximately equal in magnitude and time displacement.

#### 4.1.5 Load current

The load current shall be approximately sinusoidal. The harmonic factor shall not exceed 0.05 per unit. Harmonic factor is defined in IEEE Std C57.12.80. Refer to IEEE Std C57.110™ [B20]<sup>11</sup> for information on establishing transformer capability when supplying nonsinusoidal load currents.

#### 4.1.6 Operation above rated voltage or below rated frequency

##### 4.1.6.1 Capability

Transformers shall be capable of the following:

- a) Operating continuously above rated voltage or below rated frequency, at maximum rated kVA for any tap, without exceeding the limits of observable temperature rise in accordance with 5.11.1 when all of the following conditions prevail:

- 1) Secondary voltage and volts per hertz do not exceed 105% of rated values
- 2) Load power factor is 80% or higher
- 3) Frequency is at least 95% of rated value

NOTE—For generator step-up transformers, the maximum value of the primary voltage would be limited by the magnitude of the highest voltage the generator can supply at full load. For all other step-up transformers, the maximum value of the primary voltage would be limited by the highest system voltage at the primary of the transformer. In either case, these levels should be provided by the user and must be indicated on the nameplate of the transformer. If not provided by user, for generator step-up transformers assume 105% of rated voltage, and for all other step-up transformers, use the maximum system voltage as listed in Table 3 Column 1 for distribution and Class I power transformers, and Table 4 Column 1 for Class II power transformers, for the applicable nominal system voltage.<sup>12</sup>

- b) Operating continuously above rated voltage or below rated frequency, on any tap at no load, without exceeding limits of observable temperature rise in accordance with 5.11.1, when neither the voltage nor volts per hertz exceed 110% of rated values.

For multi-winding transformers or autotransformers, 4.1.6.1 applies only to specific loading conditions used as the basis of design. These loading conditions involve simultaneous coordination of kVA input and output, load power factors, and winding voltage combinations [see item j) of 4.3.3]. Differences in loading and voltage regulation for various output windings may prevent simultaneous achievement of 105% voltage on all output terminals. In no

<sup>11</sup> The numbers in brackets correspond to those of the bibliography in Annex D.

<sup>12</sup> Notes in text, tables, and figures of a standard are given for information only and do not contain requirements needed to implement this standard.

case shall the kVA outputs specified for any loading condition require continuous loading of any input winding in excess of its rating.

#### **4.1.6.2 Maximum continuous transformer operating voltage**

The maximum continuous transformer operating voltage should not exceed the levels specified in ANSI C84.1. System conditions may require voltage transformation ratios involving tap voltages higher than the maximum system voltage for regulation purposes. However, the appropriate maximum system voltage should be observed under operating conditions.

#### **4.1.7 Outdoor operation**

Unless otherwise specified, transformers shall be suitable for outdoor operation.

#### **4.1.8 Step-down operation**

Unless otherwise specified, transformers shall be designed for step-down operation.

##### **4.1.8.1 Generator step-up transformers**

Transformers identified as generator step-up transformers shall be designed for step-up operation.

##### **4.1.8.2 System tie transformers**

Transformers identified as system tie transformers or autotransformers shall be designed for step-down operation, or step-up operation, or both, as specified by the user.

#### **4.1.9 Tank or enclosure finish**

Temperature limits and tests shall be based on the use of a nonmetallic pigment surface paint finish. It should be noted that metallic-flake paints, such as aluminum and zinc, have properties that increase the temperature rise of transformers, except in direct sunlight.

## **4.2 Loading at other-than-rated conditions**

IEEE Std C57.91™ [B11] provides guidance for loading at other-than-rated conditions including the following:

- a) Ambient temperatures higher or lower than the basis of rating
- b) Short-time loading in excess of nameplate kVA with normal life expectancy
- c) Loading that results in reduced life expectancy

IEEE Std C57.91 [B11] is an IEEE guide, and as such, it does not specify mandatory requirements. It provides the best-known general information for loading of transformers under various conditions based on typical winding insulation systems. It is based on the best engineering information available at the time of preparation. The guide discusses limitations of ancillary components other than windings that may limit the capability of transformers. When specified, ancillary components and other construction features (such as cables, bushings, tap-changers, insulating liquid expansion space, etc.) shall be supplied in a manner that will not limit the loading to less than the specified capability of the windings.

### 4.3 Unusual service conditions

Conditions other than those described in 4.1 are considered unusual service conditions and, when prevalent, should be brought to the attention of those responsible for the design and application of the apparatus. Examples of some of these conditions are listed in 4.3.3.

#### 4.3.1 Unusual ambient temperature and altitude conditions

Transformers may be used at higher or lower ambient temperatures or at higher altitudes than those specified in 4.1.3, but special consideration should be given to these applications. IEEE Std C57.91 [B11] provides information on recommended practices.

#### 4.3.2 Insulation at high altitude

The dielectric strength of transformers that depend in whole or partly on air for insulation decreases as the altitude increases due to the effect of decreased air density. When specified, transformers shall be designed with larger air spacing between terminals using the correction factors of Table 1 to obtain adequate air dielectric strength at altitudes above 1000 m (3300 ft).

##### 4.3.2.1 Insulation level

The minimum insulation necessary at the required altitude can be obtained by dividing the standard insulation level at 1000 m (3300 ft) by the appropriate correction factor from Table 1.

##### 4.3.2.2 Bushings

Bushings with additional length or arcing distance shall be furnished when necessary for operation above 1000 m (3300 ft).

**Table 1—Dielectric strength correction factor for altitudes greater than 1000 m (3300 ft)**

Altitude m (ft)	Altitude correction factor for dielectric strength
1000 (3300)	1.00
1200 (4000)	0.98
1500 (5000)	0.95
1800 (6000)	0.92
2100 (7000)	0.89
2400 (8000)	0.86
2700 (9000)	0.83
3000 (10 000)	0.80
3600 (12 000)	0.75
4200 (14 000)	0.70
4500 (15 000)	0.67
NOTE—An altitude of 4500 m (15 000 ft) is considered a maximum for transformers conforming to this standard.	

### 4.3.3 Other unusual service conditions

Other unusual service conditions include the following:

- a) Damaging fumes or vapors, excessive or abrasive dust, explosive mixtures of dust or gases, steam, salt spray, excessive moisture or dripping water, etc.
- b) Abnormal vibration, tilting, shock, or seismic conditions.
- c) Ambient temperatures outside of normal range.
- d) Unusual transportation or storage conditions.
- e) Unusual space limitations.
- f) Unusual maintenance problems.
- g) Unusual duty or frequency of operation, or high-current short-duration loading.
- h) Unbalanced ac voltages, or departure of ac system voltages from a substantially sinusoidal wave form.
- i) Loads involving abnormal harmonic currents such as those that may result where appreciable load currents are controlled by solid-state or similar devices. Such harmonic currents may cause excessive losses and abnormal heating. See IEEE Std C57.110 [B20] for more information.
- j) Specified loading conditions (kVA outputs, winding load power factors, and winding voltages) associated with multi-winding transformers or autotransformers.
- k) Excitation exceeding either 110% rated voltage or 110% rated volts per hertz.
- l) Planned short circuits as a part of regular operating or relaying practice.
- m) Unusual short-circuit application conditions differing from those described as usual in Clause 7.
- n) Unusual voltage conditions (transient overvoltages, resonance, switching surges, etc.) may require special consideration in insulation design.
- o) Unusually strong magnetic fields. It should be noted that solar magnetic disturbances may result in the flow of geomagnetically induced current (GIC) in transformer neutrals.
- p) Large transformers with high-current isolated-phase bus ducts. It should be noted that high-current isolated-phase bus ducts with strong magnetic fields may cause unanticipated circulating currents in transformer tanks and covers, and in bus ducts. Losses resulting from these unanticipated currents may result in excessive temperatures when corrective measures are not included in the design.
- q) Parallel operation. It should be noted that while parallel operation is not unusual, it is desirable that users advise the manufacturer when paralleling with other transformers is planned and identify the transformers involved.

## 5. Rating data

### 5.1 Cooling classes of transformers

Transformers shall be identified according to the cooling method employed. For liquid-immersed transformers, this identification is expressed by a four-letter code, described as follows. These designations are consistent with IEC 60076-2:2011 [B4].

*First letter:* Internal cooling medium in contact with the windings:

- O: Insulating liquid with fire point  $\leq 300$  °C (see ASTM D92)<sup>13</sup>
- K: Insulating liquid with fire point  $> 300$  °C
- L: Insulating liquid with no measurable fire point

*Second letter:* Circulation mechanism for internal cooling medium:

- N: Natural convection flow through cooling equipment and in windings
- F: Forced circulation through cooling equipment (i.e., coolant pumps), natural convection flow in windings (also called *non-directed flow*)
- D: Forced circulation through cooling equipment, directed from the cooling equipment into at least the main windings (also called *directed flow*)

*Third letter:* External cooling medium:

- A: Air
- W: Water

*Fourth letter:* Circulation mechanism for external cooling medium:

- N: Natural convection
- F: Forced circulation (fans [air cooling], pumps [water cooling])

NOTE 1— In a transformer with forced, non-directed cooling (second code letter F), the rates of coolant flow through all the windings vary with the loading, and are not directly controlled by the pumps. The pumped insulating liquid flows freely inside the tank and is not forced to flow through the windings.

NOTE 2— In a transformer designated as having forced directed coolant circulation (second code letter D), the rate of coolant flow through the main windings is determined by the pumps and not by the loading. A minor fraction of the coolant flow through the cooling equipment may be directed outside the main windings to provide cooling for core and other parts. Regulating windings and/or other windings having relatively low power may also have non-directed coolant circulation.

A transformer may be specified with more than one kVA rating (also referred to as *cooling stages*). The transformer nameplate shall list the rated kVA and cooling class designation for each rating. The ratings shall be listed in order of increasing kVA. The cooling class designations are normally listed in order with a diagonal slash separating each one.

*Examples:*

ONAN/ONAF. The transformer has a set of fans that may be put in service as desired at high loading. The coolant circulation is by natural convection only.

ONAN/OFAF. The coolant circulation is by natural convection only at base loading. However, the transformer has cooling equipment with pumps and fans to increase the power-carrying capacity at high loading.

---

<sup>13</sup> *Fire point:* The lowest temperature at which a specimen will sustain burning for 5 s (ASTM D92, *Cleveland Open Cup* test method).

Examples of the cooling class designations used in IEEE Std C57.12.00-2006 and in previous revisions, with the corresponding new designations, are provided in Annex A.

## 5.2 Frequency

Unless otherwise specified, transformers shall be designed for operation at a frequency of 60 Hz.

## 5.3 Phases

### 5.3.1 General

Transformers described in this standard are either single phase or three phase. Standard ratings are included in product standards for particular types of transformers. When specified, other phase arrangements may be provided.

### 5.3.2 Scott-connected or T-connected transformers

#### 5.3.2.1 Phase transformation

These may be provided to accomplish three-phase to two-phase transformation, or vice versa, or to accomplish three-phase to three-phase transformation. Common arrangements used to accomplish such transformations are described here in 5.3.2.2, 5.3.2.3, and 5.3.2.4.

#### 5.3.2.2 Dissimilar single-phase transformers

Two single-phase transformers are assembled in an enclosure, and permanently interconnected, with the following characteristics:

- a) Performance characteristics shall be based on bank operation of three-phase to two-phase transformation or vice versa.
- b) The single-phase transformers may not be identical or interchangeable.

#### 5.3.2.3 Three-legged core

Another arrangement uses a three-legged core with main and teaser coil assemblies located on the two outer legs, and a center leg that has no coil assembly. This provides a common magnetic circuit for the two outer legs.

#### 5.3.2.4 Identical single-phase transformers

When specified, two identical single-phase transformers shall be furnished.

- a) The kVA rating of each transformer shall be half the bank output required. The rating of the individual units shall agree with the ratings established for single-phase transformers.
- b) Performance characteristics (except heating) shall be based on single-phase operation.
- c) The temperature rise shall be based on delivering the required bank capacity when transforming from three-phase to two-phase or from two-phase to three-phase, as specified.
- d) Transformers shall be interchangeable as main and teaser.
- e) Regulating taps are not usually supplied on transformers for three-phase to two-phase or from two-phase to three-phase service. When taps are required, the teaser tap shall be 86.6% of the mean regulating taps (used here, *mean* refers to the midpoint of the range of regulating taps).

## 5.4 Rated kilovoltamperes

### 5.4.1 General

The rated kVA of a transformer shall be the output that can be delivered for the time specified at rated secondary voltage and rated frequency without exceeding the specified temperature-rise limitations under prescribed conditions of test, and within the limits of established standards.

### 5.4.2 Preferred continuous kVA ratings

Preferred continuous kVA ratings of single-phase and three-phase distribution and power transformers are based on an average winding rise of 65 °C, in accordance with 5.11.1.1 and are listed in Table 2.

**Table 2—Preferred continuous kilovoltampere ratings**

Single-phase transformers (kVA)	Three-phase transformers (kVA)
5	15
10	30
15	45
25	75
37.5	112.5
50	150
75	225
100	300
167	500
250	750
333	1000
500	1500
—	2000
833	2500
1250	3750
1667	5000
2500	7500
3333	10 000
—	12 000
5000	15 000
6667	20 000
8333	25 000
10 000	30 000
12 500	37 500
16 667	50 000
20 000	60 000
25 000	75 000
33 333	100 000

## 5.5 Voltage ratings and taps

### 5.5.1 General

Standard nominal system voltages and maximum system voltages are included in ANSI C84.1 and listed in Table 3 and Table 4.

### 5.5.2 Voltage ratings

The voltage ratings shall be at no load and shall be based on the turn's ratio.

### 5.5.3 Ratings of transformer taps

Whenever a transformer winding is provided with taps for de-energized operation, they shall be full-capacity taps. Transformers with load tap-changing equipment may have reduced capacity taps, unless specified otherwise, for taps below rated winding voltage. When specified, other capacity taps may be provided. In all cases, the ampacity at each tap shall be stated on the nameplate.

## 5.6 Connections

Standard connection arrangements are included in the standards for particular types of transformers and in IEEE Std C57.12.70.

## 5.7 Polarity, angular displacement, and terminal marking

### 5.7.1 Polarity of single-phase transformers

Single-phase transformers 200 kVA and below with high-voltage ratings of 8660 V and below (winding voltage) shall have additive polarity. All other single-phase transformers shall have subtractive polarity. Transformer polarity is defined and illustrated in IEEE Std C57.12.90.

### 5.7.2 Angular displacement (nominal) between voltages of windings for three-phase transformers

The angular displacement of a polyphase transformer is the time angle expressed in degrees between the line-to-neutral voltage of the reference identified high-voltage terminal  $H_1$  and the line-to-neutral voltage of the corresponding identified low-voltage terminal  $X_1$ .

Unless specified otherwise and identified on the nameplate, the angular displacement between high-voltage and low-voltage phase voltages of three-phase transformers with  $\Delta$ - $\Delta$  or Y-Y connections shall be zero degrees.

The angular displacement between high-voltage and low-voltage phase voltages of three-phase transformers with Y- $\Delta$  or  $\Delta$ -Y connections shall be  $30^\circ$ , with the low voltage lagging the high voltage as shown in Figure 1.

Additional phasor diagrams are described in IEEE Std C57.12.70.

### 5.7.3 Terminal markings

Terminal markings shall be in accordance with IEEE Std C57.12.70.

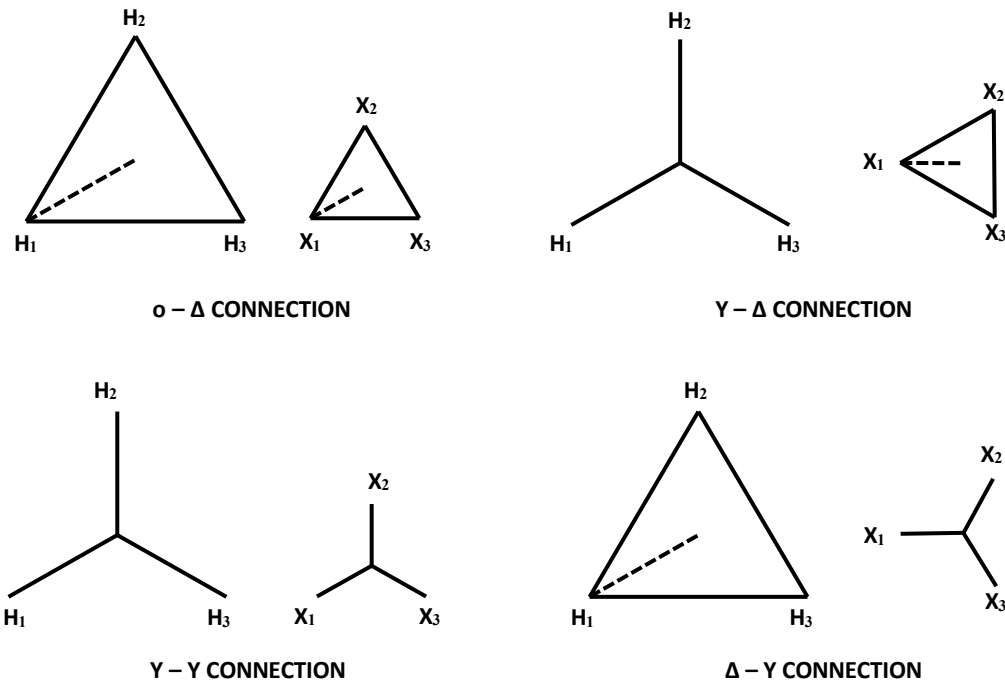

Figure 1—Phase relation of terminal designation for three-phase transformers

## 5.8 Impedance

The impedance shall be referred to the reference temperature defined as 20 °C plus the rated average winding rise. Preferred standard values of impedance are included in the product standards for particular types of transformers.

## 5.9 Total losses

The total losses of a transformer shall be the sum of the no-load losses and the load losses.

The losses of cooling fans, insulating liquid pumps, space heaters, and other ancillary equipment are not included in the total losses. When specified, power loss data on such ancillary equipment shall be furnished.

The standard reference temperature for the load losses of power and distribution transformers shall be defined as 20 °C plus the rated average winding rise. The standard reference temperature for the no-load losses of power and distribution transformers shall be 20 °C.

For Class II transformers (see 5.10), control/auxiliary (cooling) losses shall be measured and recorded. All stages of cooling, pumps, heaters, and all associated control equipment shall be energized, provided these components are integral parts of the transformer.

## 5.10 Insulation levels

Transformers shall be designed to provide coordinated low-frequency and impulse insulation levels on line terminals and low-frequency insulation levels on neutral terminals. The primary identity of a set of coordinated levels shall be its *maximum system voltage* and basic lightning impulse insulation level (BIL). BIL will be selected dependent on the degree of exposure of the transformer and characteristics of the overvoltage protection system.

The system voltage and the type of transformer may also influence insulation levels and test procedures. Therefore, power transformers are separated into two different classes as follows:

- a) Class I power transformers are any that are not categorized as Class II, described in item b).
- b) Class II power transformers shall include power transformers with high-voltage windings rated for 115 kV nominal system voltage and above, and also power transformers with high-voltage windings rated 69 kV through 115 kV nominal system voltage, having a top nameplate rating of at least 15 000 kVA for three-phase transformers or 10 000 kVA for single-phase transformers.

The following tables show various system voltages, insulation, and test levels for various classes of liquid-immersed power transformers:

- Table 3 lists dielectric insulation and low-frequency test levels for distribution and Class I power transformers.
- Table 4 lists dielectric insulation and low-frequency test levels for Class II power transformers.
- Table 5 lists high-frequency test levels.

### 5.10.1 Front-of-wave insulation level

Front-of-wave insulation levels and tests shall be specified when desired; otherwise, withstand insulation capability is not required.

Annex B includes the last published IEEE C57.12.00 front-of-wave test levels for historical reference. See Annex B.

-----

**Table 3—Dielectric insulation levels for distribution and Class I power transformers, voltages in kV**

Maximum system voltage (kV rms)	Nominal system voltage <sup>a, g</sup> (kV rms)	Applied-voltage test <sup>f</sup> (kV rms)			Induced-voltage test <sup>b, f</sup> (phase to ground) (kV rms)	Winding line-end BIL <sup>c, f</sup> (kV crest)			Neutral BIL <sup>d, f, h</sup> (kV crest)	
		Delta or fully insulated wye	Grounded wye	Impedance grounded wye or grounded wye with higher BIL		Minimum	Alternates	Grounded wye	Impedance grounded wye or grounded wye with higher BIL	
Col 1	Col 2	Col 3	Col 4	Col 5	Col 6	Col 7	Col 8	Col 9	Col 10	Col 11
<b>Distribution transformers</b>										
1.5	1.2 <sup>e</sup>	10	—	10	1.4	<b>30</b>			30	30
3.5	2.5 <sup>e</sup>	15	—	15	2.9	<b>45</b>			45	45
6.9	5 <sup>e</sup>	19	—	19	5.8	<b>60</b>			60	60
11	8.7 <sup>e</sup>	26	—	26	10	<b>75</b>			75	75
17	15	34	—	34	17	<b>95</b>	110		75	75
26	25	40	—	40	29	<b>125</b>	<b>150</b>		75	95
36	34.5	50	—	50	40	125	<b>150</b>	<b>200</b>	75	125
48	46	95	—	70	53	200	<b>250</b>		95	150
73	69	140	—	95	80	250	<b>350</b>		95	200
<b>Class I power transformers</b>										
1.5	1.2	10	10	10	1.4	<b>30</b>	<b>45</b>		45	45
3.5	2.5	15	15	15	2.9	<b>45</b>	<b>60</b>		60	60
6.9	5	19	19	19	5.8	<b>60</b>	<b>75</b>		75	75
11	8.7	26	26	26	10	<b>75</b>	<b>95</b>		95	95
17	15	34	26	34	17	<b>95</b>	<b>110</b>		95	110
26	25	50	26	40	29	<b>150</b>			95	125
36	34.5	70	26	50	40	<b>200</b>			95	150
48	46	95	34	70	53	200	<b>250</b>		110	200
73	69	140	34	95	80	250	<b>350</b>		110	250

<sup>a</sup>For nominal system voltage greater than maximum system voltage, use the next higher voltage class for applied-voltage test levels.

<sup>b</sup>Induced-voltage tests shall be conducted at  $2.0 \times$  nominal system voltage for 7200 cycles.

<sup>c</sup>Bold typeface BILs are the most commonly used standard levels.

<sup>d</sup>Y-Y-connected transformers using a common solidly grounded neutral may use neutral BIL selected in accordance with the low-voltage winding rating.

<sup>e</sup>Single-phase distribution and power transformers and regulating transformers for voltage ratings between terminals of 8.7 kV and below are designed for both Y and  $\Delta$  connection, and are insulated for the test voltages corresponding to the Y connection so that a single line of transformers serves for the Y and  $\Delta$  applications. The test voltages for such transformers, when connected and operated, are therefore higher than needed for their voltage rating.

<sup>f</sup>For series windings in transformers, such as regulating transformers, the test values to ground shall be determined by the BIL of the series windings rather than by the rated voltage between terminals.

<sup>g</sup>Values listed as nominal system voltage in some cases (particularly voltages 34.5 kV and below) are applicable to other lesser voltages of approximately the same value. For example, 15 kV encompasses nominal system voltages of 14 440 V, 13 800 V, 13 200 V, 13 090 V, 12 600 V, 12 470 V, 12 000 V, and 11 950 V.

<sup>h</sup>Neutral BIL shall never exceed winding BIL.

**Table 4—Dielectric insulation levels for all windings of Class II power transformers, voltages in kV**

Maximum system voltage (kV rms)	Nominal system voltage <sup>a</sup> (kV rms)	Applied-voltage test <sup>g</sup> (kV rms)			Induced-voltage test <sup>b, c</sup> (phase to ground) (kV rms)		Winding line-end BIL <sup>d</sup> (kV crest)			Neutral BIL <sup>e, g</sup> (kV crest)		
		Delta and fully insulated wye	Grounded wye	Impedance grounded wye or grounded wye with higher BIL	Enhanced 7200 cycle	One hour	Minimum	Alternates		Grounded wye	Impedance grounded wye or grounded wye with higher BIL	
Col 1	Col 2	Col 3	Col 4	Col 5	Col 6	Col 7	Col 8	Col 9	Col 10	Col 11	Col 12	Col 13
≤ 17	≤ 15	34	34	34	16	14	<b>110</b>				110	110
26	25	50	34	40	26	23	<b>150</b>				110	125
36	34.5	70	34	50	36	32	<b>200</b>				110	150
48	46	95	34	70	48	42	200	<b>250</b>			110	200
73	69	140	34	95	72	63	250	<b>350</b>			110	250
121	115	173	34	95	120	105	350	<b>450</b>	550		110	250
145	138	207	34	95	145	125	450	<b>550</b>	650		110	250
169	161	242	34	140	170	145	550	<b>650</b>	750	825	110	350
242	230	345	34	140	240	210	650	<b>750</b>	<b>825</b>	<b>900</b>	110	350
362	345	518	34	140	360	315	900	1050	1175		110	350
550	500	N/A	34	140	550 <sup>f</sup>	475 <sup>f</sup>	1425	1550	1675		110	350
765	735	N/A	34	140	880 <sup>f</sup>	750 <sup>f</sup>	1950 <sup>f</sup>	2050			110	350
800	765	N/A	34	140	885 <sup>f</sup>	795 <sup>f</sup>	1950 <sup>f</sup>	2050			110	350

<sup>a</sup>For nominal system voltage greater than maximum system voltage, use the next higher voltage class for applied-voltage test levels.

<sup>b</sup>Induced-voltage tests shall be conducted at  $1.58 \times$  nominal system voltage for one hour and  $1.80 \times$  nominal system voltage for enhanced 7200 cycle test.

<sup>c</sup>Column 6 and Column 7 provide phase-to-ground test levels that would normally be applicable to wye windings. When the test voltage level is to be measured phase-to-phase (as is normally the case with delta windings), the levels in Column 6 and Column 7 must be multiplied by 1.732 to obtain the required phase-to-phase induced-voltage test level.

<sup>d</sup>Bold typeface BILs are the most commonly used standard levels.

<sup>e</sup>Y-Y-connected transformers using a common solidly grounded neutral may use neutral BIL selected in accordance with the low-voltage winding rating.

<sup>f</sup>For 500 kV to 765 kV nominal system voltages, induced-voltage test levels do not follow rules in footnote b, and 1950 kV BIL is not a standard IEEE level.

<sup>g</sup>If user specifies a different BIL for the neutral than indicated above, the applied test voltage shall also be specified.

## 5.10.2 Line terminals

### 5.10.2.1 Basic lightning impulse insulation level (BIL)

A basic lightning impulse insulation level (BIL) from Table 3 or Table 4 shall be assigned to each line terminal of a winding. The associated insulation levels shall be provided regardless of whether tests are or can be performed.

### 5.10.2.2 Switching impulse insulation level

Windings for system voltages 115 kV and above shall be designed for the basic switching impulse insulation levels (BSL) associated with the assigned BIL as shown in Table 5. In addition, low-voltage windings shall be designed to withstand stresses from switching impulse tests on high-voltage windings regardless of whether or not such tests are specified.

**Table 5—Lightning and switching impulse (high-frequency) tests table**

Lightning impulse (BIL) kV crest $1.2 \times 50 \mu\text{s}$	Chopped wave			Switching impulse (BSL)  kV crest
	kV crest	Minimum time to flashover ( $\mu\text{s}$ )		
	$1.1 \times \text{BIL}$	Class I and distribution	Class II	
Col 1	Col 2	Col 3	Col 4	Col 5
30	33	1.0	2.0	—
45	50	1.5	2.0	—
60	66	1.5	2.0	50
75	83	1.5	2.0	62
95	105	1.8	2.0	79
110	120	2.0	2.0	92
125	138	2.3	2.3	104
150	165	3.0	3.0	125
200	220	3.0	3.0	166
250	275	3.0	3.0	208
350	385	3.0	3.0	291
450	495	N/A	3.0	375
550	605	N/A	3.0	460
650	715	N/A	3.0	540
750	825	N/A	3.0	620
825	910	N/A	3.0	685
900	990	N/A	3.0	745
1050	1155	N/A	3.0	870
1175	1290	N/A	3.0	975
1300	1430	N/A	3.0	1080
1425	1570	N/A	3.0	1180
1550	1705	N/A	3.0	1290
1675	1845	N/A	3.0	1390
1800	1980	N/A	3.0	1500
1950 <sup>a</sup>	2145	N/A	3.0	1550/1620
2050	2255	N/A	3.0	1700

<sup>a</sup>For 1950 kV BIL, a switching impulse (BSL) of 1550 kV is specified by some users. A common BSL of 1620 kV should be used for the 1950 kV BIL.

### 5.10.2.3 Wye-winding line terminal

Each wye-winding line terminal shall be specified on the nameplate as suitable or unsuitable for ungrounded neutral operation.

### 5.10.2.4 Windings that have no terminals brought out

Windings that have no terminals brought out shall be capable of withstanding voltages resulting from the various tests that may be applied to other terminals corresponding to their respective BIL.

## 5.10.3 Neutral terminals

### 5.10.3.1 Wye connection with an accessible neutral external to the tank

A transformer winding designed for wye connection only and with an accessible neutral external to the tank shall be assigned a low-frequency test level for the neutral terminal. This assigned low-frequency test level may be lower than that for line terminals.

### 5.10.3.2 Neutral terminals that are solidly grounded

The assigned low-frequency test level for neutral terminals that are solidly grounded directly or through a current transformer shall be not less than that specified in Column 4 of Table 3 and Table 4.

The assigned low-frequency test level for other cases shall be coordinated with voltages that can occur between the neutral and ground during normal operation or during fault conditions, but shall be not less than those specified in Columns 3, 4, and 5 of Table 3 and Table 4.

It should be noted that IEEE Std C57.32™ [B10] includes additional information on neutral insulation, application, etc.

### 5.10.3.3 Specific BIL

When specified, neutral terminals shall be designed for a specific BIL and a low-frequency test level.

### 5.10.3.4 Insulation level of the neutral bushing

The insulation level of the neutral end of a winding may differ from the insulation level of the neutral bushing being furnished or of the bushing for which provision for future installation is made. In any case, the insulation level of the neutral bushing shall be equal to or greater than the specified insulation level of the neutral end of the winding.

### 5.10.3.5 Neutral not brought out of the tank

Insulation levels shall not be assigned where the neutral end of the winding is not brought out of the tank through a bushing and is solidly grounded to the tank.

## 5.10.4 Coordination of insulation levels

### 5.10.4.1 BIL levels

The BIL chosen for each line terminal shall be such that the lightning impulse, chopped-wave impulse, and switching impulse insulation levels include a suitable margin in excess of the dielectric stresses to which the terminal will be subjected in actual service. For information on surge arrester characteristics and application, see IEEE Std C62.1™-1989 [B46], IEEE Std C62.2™-1989 [B47], IEEE Std C62.11™ [B48], and IEEE Std

C62.22™ [B49]. It should be noted that it is recommended that surge-arrester protection be provided for tertiary windings that have terminals brought out.

#### **5.10.4.2 BSL levels**

A switching surge impulse occurring at one terminal during test or in actual service will be transferred to other winding terminals with a magnitude approximately proportional to the turns ratio involved. This interaction should be considered when evaluating surge arrester application, evaluating expected magnitude of surges, and establishing coordinated insulation levels.

### **5.10.5 Low-frequency voltage tests on line terminals for distribution transformers and power transformers**

#### **5.10.5.1 General**

Low-frequency test requirements for distribution and power transformers shall be applied-voltage tests and induced-voltage tests. Table 3 specifies test levels for distribution and Class I power transformers; Table 4 specifies test levels for Class II power transformers.

#### **5.10.5.2 Applied-voltage test requirements**

A voltage to ground (not necessarily to neutral) shall be developed at each terminal in accordance with the levels specified in Table 3 or Table 4. For ungraded windings, this voltage shall be maintained throughout the winding.

#### **5.10.5.3 Induced-voltage test requirements for distribution and Class I power transformers**

A voltage shall be developed in each winding in accordance with the levels specified in Table 3. Induced-voltage tests shall be conducted at  $2.0 \times$  nominal voltage for 7200 cycles.

#### **5.10.5.4 Exceptions**

Exceptions to the applied-voltage and induced-voltage tests requirements are as follows:

- a) Subject to the limitation that the voltage-to-ground test shall be performed as specified in 5.10.5.2 on the line terminals of the winding with the lowest ratio of test voltage to minimum turns, the test levels may otherwise be reduced so that none of the three test levels required in 5.10.5.3 need be exceeded to meet the requirements of the other two, or so that no winding need be tested above its specified level to meet the test requirements of another winding.
- b) For delta windings, the voltage-to-ground developed at each terminal shall be in accordance with Table 3 for the BIL specified; however, voltage within the winding may be reduced to 87% of the voltage developed at the terminals.

#### **5.10.5.5 Induced-voltage test for Class II power transformers**

With the transformer connected and excited as it will be in service, an induced-voltage test shall be performed as indicated in Figure 2, at voltage levels indicated in Columns 6 and 7 of Table 4. Minimum line-to-ground induced test levels for Class II power transformers shall be a multiple of corresponding line-to-ground nominal system voltage as follows: 1.58 times for one-hour tests and 1.8 times for 7200 cycles enhancement level tests.

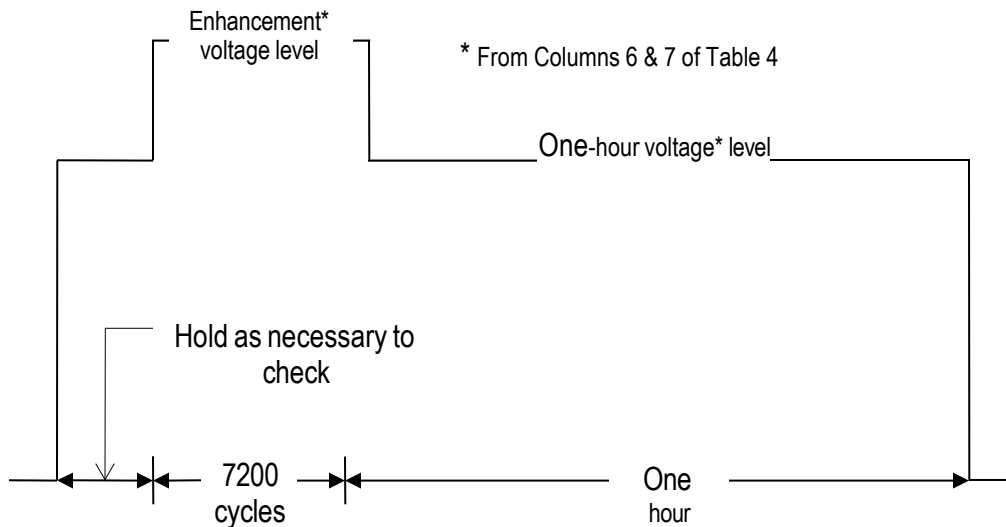

**Figure 2—Induced-voltage test for Class II power transformers**

### 5.10.6 Low-frequency voltage tests on neutral terminals for all transformers

Each neutral terminal shall receive an applied-voltage test at its assigned low-frequency insulation level in accordance with the test levels specified in Table 3 or Table 4.

### 5.10.7 Impulse tests

#### 5.10.7.1 Lightning impulse tests

When required, lightning impulse tests shall be performed on line and neutral terminals at the specified levels per Columns 1 and 2 of Table 5, as selected from either Table 3 or Table 4. Lightning impulse tests shall not be made on windings that do not have terminals brought out through the tank or cover. Lightning impulse tests are not required on terminals brought out from buried windings in the following cases:

- a) When a single terminal is brought out for the purpose of grounding the buried winding.
- b) When two terminals are brought out so that the delta connection may be opened for the purpose of testing the buried winding.
- c) When temporary connections to terminals of a buried winding are brought out only for the purpose of factory tests.

#### 5.10.7.2 Switching impulse tests

When required, switching impulse tests shall be performed. Switching impulse tests on the high-voltage line terminals may over-test or under-test other line terminals depending on the relative BSL levels, the turns ratios between windings, and test connections. Regardless of this fact, tests on the high-voltage terminals shall be controlling, and a switching impulse test at the level specified in Column 5 of Table 5 shall be applied to the high-voltage terminals.

The switching surge insulation of other windings shall be able to withstand voltages resulting from the required switching impulse tests to the high-voltage terminals, even though such voltages on the other windings may exceed their designated BSL listed in Table 5 when applicable.

When the application of the switching impulse to the high-voltage terminals results in a voltage on another winding lower than the BSL requirement for that winding in Table 5, no additional test is necessary to demonstrate switching surge insulation withstand capability on that winding.

## 5.11 Temperature rise and loading conditions

### 5.11.1 Limits of observable temperature rise

#### 5.11.1.1 Winding temperature rises

The average winding temperature rise above ambient temperature shall not exceed 65 °C at rated kVA when tested in accordance with IEEE Std C57.12.90 using the combination of connections and taps that give the highest average winding temperature rise.

The maximum (hottest-spot) winding temperature rise above ambient temperature shall not exceed 80 °C at rated kVA for the particular combination of connections and taps that give the highest maximum (hottest-spot) winding temperature rise. The maximum (hottest-spot) winding temperature rise above ambient shall be determined by one of the following methods:

- a) Direct measurement during a thermal test in accordance with IEEE Std C57.12.90. A sufficient number of direct reading sensors should be used at expected locations of the maximum temperature rise as indicated by prior testing or loss and heat transfer calculations. For additional guidance on the use and location of thermal sensors, refer to IEEE Std 1538™ [B8].
- b) Direct measurement on an exact duplicate transformer design per item a).
- c) Calculations of the temperatures throughout each active winding and all leads. The calculation method shall be based on fundamental loss and heat transfer principles and substantiated by tests on production or prototype transformers or windings.

The maximum (hottest-spot) winding temperature rise above ambient temperature shall be included in the test report, with the other temperature rise data. A note shall indicate which of the preceding methods was used to determine the value.

#### 5.11.1.2 Thermal rating for stabilizing windings (buried tertiary)

In addition to the short-circuit duty (see 7.1.4.4), stabilizing windings shall be designed to withstand the transient and continuous thermal duty as specified by the user and in accordance with the allowable temperature limits of 5.11.1.

In the event that no continuous thermal duty for the stabilizing winding can be established from the user's specification, the manufacturer shall design the stabilizing winding considering the circulating current in that winding resulting from a full single-phase load in the largest main secondary winding. The manufacturer shall determine the kVA rating for the stabilizing winding based on the transformer's equivalent circuit for a single-phase loading condition.

The manufacturer shall calculate values of average and hottest-spot temperatures for the stabilizing winding to verify compliance with allowable temperatures. Initial conditions for these calculations shall be based on the transformer operating at its maximum continuous rating, before switching to the loading conditions described above in the first or second paragraph, whichever is applicable.

NOTE—In this clause, *transformer* is a general term for two winding transformers and autotransformers.

### 5.11.1.3 Other winding rises

Other winding rises may be recognized for unusual ambient conditions or for special applications. These are specified in appropriate applications or in certain product standards. Refer to IEEE Std C57.154™ [B28] for additional guidance on the design and application of high-temperature transformers.

### 5.11.1.4 Rises of metallic parts other than windings

Metallic parts in contact with current-carrying conductor insulation shall not attain a temperature rise in excess of the winding hottest-spot temperature rise.

The core hot spot temperature shall be limited to 130 °C for the condition of highest core over-excitation, rated load, and the maximum average daily ambient temperature for transformers filled with mineral oil. This is to avoid the problem of gas generation in the core caused by thermal breakdown of the thin oil film between the core laminations. Under the same operating conditions, the core surface temperatures shall be limited by the temperature capability of the insulation materials in contact with the core surfaces.

Metallic parts other than those previously described shall not attain excessive temperature rises at maximum rated load. Excessive temperature rise shall be interpreted to mean a temperature rise that results in an operating temperature that would exceed the temperature limits of the insulation material that is in contact with the metallic part.

### 5.11.1.5 Liquid temperature rise

The insulating liquid temperature rise above ambient temperature shall not exceed 65 °C when measured near the top of the main tank.

## 5.11.2 Conditions under which temperature rise limits apply

Temperature limits shall not be exceeded when the transformer is operating on the connection that will produce the highest winding temperature rise above ambient temperature and is delivering the following:

- a) Rated kVA output at rated secondary voltage when there are no taps.
- b) Rated kVA output at the rated secondary voltage for that connection when it is a rated kVA tap connection.
- c) At the rated secondary voltage of that connection, the kVA output corresponding to the rated current of the tap, when the connection is a reduced kVA tap connection.
- d) A specified combination of kVA outputs at specified power factors (for each winding) for multi-winding transformers.
- e) Rated kVA output at rated V/Hz.

NOTE—As used here, the term *rated secondary voltage* or *rated current* means the value assigned by the manufacturer and shown on the nameplate.

### 5.11.3 Basis for temperature limits

Transformers that meet the temperature and loading conditions in this standard shall be manufactured using *thermally upgraded paper* or an alternative insulation system that has been proven to possess minimum aging characteristics that either match or exceed those of thermally upgraded paper. Cellulose paper that has not been chemically modified to improve its thermal characteristics does not qualify as thermally upgraded insulation. This requirement applies to the insulation components that determine the minimum life expectancy, such as winding insulation, layer-to-layer insulation, lead insulation, and other components.

The test procedures to determine the aging characteristics and the minimum life expectancy of an insulation system are provided in IEEE Std C57.100™ [B15].

Acceptable thermal aging performance may be assumed if the insulation system, when tested in accordance with IEEE Std C57.100 [B15] demonstrates a minimum life expectancy of at least 20.5 years (180 000 h), when operated at the hottest-spot temperature, at rated load, as defined in this clause. The minimum insulation life expectancy curve is displayed in Figure 3 and is determined by Equation (1)

$$\text{LIFE} = e^{\left[ \frac{15\,000 - 27.064}{T + 273} \right]} \quad (1)$$

where

LIFE is the life in hours  
 $T$  is the hottest-spot temperature in °C  
 $e$  is the base of natural logarithm

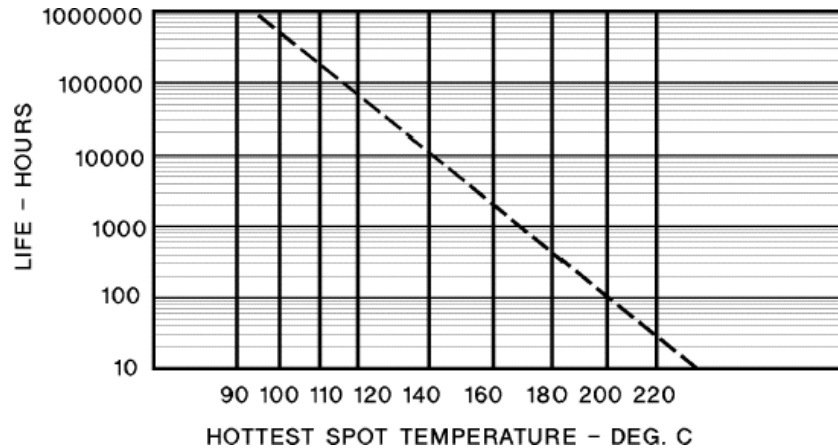

**Figure 3—Minimum life expectancy curve for liquid-immersed distribution, power, and regulating transformers rated in accordance with Clause 5, at 65 °C average winding rise, 80 °C hottest-spot rise**

## 5.12 Nameplates

### 5.12.1 General

A durable metal nameplate shall be affixed to each transformer by the manufacturer. Unless otherwise specified, it shall be made of corrosion-resistant material. It shall bear the rating and other essential operating data as specified in 5.12.2. This standard recognizes the use of metric (SI) and imperial (U.S. customary) units for data appearing on transformer nameplates. It should be noted that although this standard recognizes the possibility of using SI units as an alternative to the U.S. customary units used in the past, it is not intended that both appear on the specific nameplate. However, units used *shall* be explicitly shown.

In accordance with the requirements of IEEE Std C57.131, load tap changer (LTC) transformers shall also contain a tap-changer nameplate, permanently attached to the LTC compartment.

### 5.12.2 Nameplate information

Unless otherwise specified, the minimum information shown on the nameplate shall be that specified in Table 6 and its associated notes, and shall be in accordance with the following categories:

- a) Nameplate A shall be used on transformers rated 500 kVA or below with a high-voltage BIL less than 150 kV.
- b) Nameplate B shall be used on transformers rated 500 kVA or below, which are not covered in item a).
- c) Nameplate C shall be used on transformers rated above 500 kVA.

**Table 6—Nameplate information**

Row	Nameplate A	Nameplate B	Nameplate C
1	Serial number <sup>a</sup>	Serial number <sup>a</sup>	Serial number <sup>a</sup>
2	Month/year of manufacture	Month/year of manufacture	Month/year of manufacture
3	Class (ONAN, ONAF, etc.) <sup>b</sup>	Class (ONAN, ONAF, etc.) <sup>b</sup>	Class (ONAN, ONAF, etc.) <sup>b</sup>
4	Number of phases	Number of phases	Number of phases
5	Frequency	Frequency	Frequency
6	kVA rating <sup>a, b</sup>	kVA rating <sup>a, b</sup>	kVA (or MVA) rating <sup>a, b</sup>
7	Voltage ratings <sup>a, c</sup>	Voltage ratings <sup>a, c</sup>	Voltage ratings <sup>a, c</sup>
8	Tap voltages <sup>d</sup>	Tap voltages <sup>d</sup>	Tap voltages <sup>d</sup>
9	Temperature rise, °C	Temperature rise, °C	Temperature rise, °C
10	Polarity (single-phase transformers)	Polarity (single-phase transformers)	Polarity (single-phase transformers)
11	Phasor diagram (polyphase transformers)	Phasor diagram (polyphase transformers)	Phasor diagram (polyphase transformers)
12	Percent impedance <sup>e</sup>	Percent impedance <sup>e</sup>	Percent impedance <sup>e</sup>
13	—	Basic lightning impulse insulation levels (BIL) <sup>f</sup>	Basic lightning impulse insulation levels (BIL) <sup>f</sup>
14	Approximate total mass in kg or weight in lb <sup>g</sup>	Approximate total mass in kg or weight in lb <sup>h</sup>	Approximate total mass in kg or weight in lb <sup>h</sup>
15	Connection diagram <sup>i</sup>	Connection diagram <sup>i</sup>	Connection diagram <sup>i</sup>
16	Name and location (country) of manufacturer	Name and location (country) of manufacture	Name and location (country) of manufacture
17	Installation and operating instructions reference	Installation and operating instructions reference	Installation and operating instructions reference
18	The word <i>transformer</i> or <i>autotransformer</i>	The word <i>transformer</i> or <i>autotransformer</i>	The word <i>transformer</i> or <i>autotransformer</i>
19	Type of insulating liquid (generic name preferred) <sup>j</sup>	Type of insulating liquid (generic name preferred) <sup>j</sup>	Type of insulating liquid (generic name preferred) <sup>j</sup>
20	Conductor material (of each winding)	Conductor material (of each winding)	Conductor material (of each winding)
21	Liquid volume	—	Step-up operation suitability <sup>k</sup>
22	—	—	Maximum value of primary voltage <sup>l</sup>
23	—	—	Tank, pressure, and liquid data <sup>m</sup>
24	Department of Energy (DOE) compliant <sup>n</sup>	DOE compliant <sup>n</sup>	DOE compliant <sup>n</sup>

<sup>a</sup> The letters and numerals showing kVA, serial number, and voltage ratings shall have a minimum height of 4.00 mm (0.157 in) whether engraved or stamped. The height of other letters and numerals shall be optional with the manufacturer.

<sup>b</sup> When the class of transformer involves more than one kVA (or MVA) rating, all ratings shall be shown. Any winding, such as a tertiary winding, that has a different rating shall have its kVA (or MVA) suitably described. When the transformer has more than one temperature rating, the additional rating shall be shown on the nameplate. Provision for future forced-cooling equipment shall be indicated.

<sup>c</sup> The voltage ratings of a transformer or autotransformer shall be designated by the voltage rating of each winding separated by a dash (-) or voltages may be listed in tables. The winding voltage ratings shall be designated as specified in Table 7 and Table 8.

When the transformer is suitable for Y connection, the nameplate shall be so marked. The nameplate on two-winding single-phase transformer insulated for Y connection on both windings, shall show the Y voltage on the high-voltage side only for transformers that have a high-voltage rating above 600 V.

<sup>d</sup>The tap voltages of a winding shall be designated by listing the winding voltage of each tap, separated by a solidus (/), or shall be listed in tabular form. The rated voltage of each tap shall be shown in volts, except that for transformers rated 500 kVA and smaller with taps in uniform 2.5% or 5% steps, they may be shown as percentages of rated voltage.

Taps shall be identified on the transformer nameplate by means of letters in sequence or Arabic numerals. The numeral “1” or letter “A” shall be assigned to the voltage rating providing the maximum ratio of transformation with tap-changers for de-energized operation. (The ratio of transformation is defined as the high-voltage volts divided by the low-voltage volts.)

The neutral position (the position in which the LTC circuit has no effect on the output voltage) shall be designated by the letter “N” for LTCs. The raise positions shall be designated by Arabic numerals in ascending order corresponding to increasing output voltage, followed by the suffix “R,” such as 1R, 2R, etc. The lower positions shall be designated by Arabic numerals in ascending order, corresponding to decreasing output voltage, followed by the suffix “L,” such as 1L, 2L, etc. (this applies to the relationship between two windings of a transformer only, such as the H and X windings).

In the event of system requirements such as reversal of power flow, regulation of input voltage (LTC in the primary winding), or any unusual conditions, nameplates shall have raise-lower designations specified by the user. This applies to two-winding transformers only.

The rated currents of all windings at the highest kVA rating and on all tap connections shall be shown for transformers rated 501 kVA and larger.

Any reduced capacity taps shall be identified.

<sup>e</sup>Percent impedance shall be given between each pair of windings and shall be the tested value for transformers rated 501 kVA and larger. The voltage connection shall be stated following each percent impedance. When the transformer has more than one kVA rating, the kVA base shall be given.

<sup>f</sup>Full-wave BIL of line and neutral terminals (where applicable) shall be designated as in the following example:

High-voltage winding	450 kV BIL
High-voltage winding neutral	110 kV BIL
Low-voltage winding	95 kV BIL

<sup>g</sup>Weight may be omitted from the nameplate for transformers rated below 37.5 kVA single-phase or below 30 kVA polyphase. In this case, supplemental data shall be available showing the required volume of insulating liquid and the approximate weight of the transformer.

<sup>h</sup>The approximate weights shall be shown as follows:

- a) Core and coils
- b) Tank and fittings
- c) Liquid
- d) Total weight
- e) Untanking weight (heaviest piece)
- f) Original shipping weight, if different than total weight

<sup>i</sup>All winding terminations shall be identified on the nameplate or on the connection diagram. A schematic plan view shall be included, preferably indicating orientation by locating a fixed accessory such as the de-energized tap-changer handle, the LTC, instruments, or other prominent items. All termination or connection points shall be permanently marked to agree with the schematic identification. In general, the schematic view should be arranged to show the low-voltage side at the bottom and the H, high-voltage terminal, at the top left. (This arrangement may be modified in particular cases, such as multi-winding transformers that are equipped with terminal locations that do not conform to the suggested arrangement.)

Indication of voltage transformers, potential devices, current transformers, winding temperature devices, etc., when used, shall be shown.

Any nonlinear devices, capacitors, or resistors installed on the winding assembly or on any tap-changer shall be indicated on the nameplate.

Polarity and location of current transformers shall be identified when used for metering, relaying, or line drop compensation. Polarity need not be shown when current transformers are used for winding temperature equipment or cooling control.

All internal leads and terminals not permanently connected shall be identified with numbers or letters in a manner that permits convenient reference to prevent confusion with terminal and polarity markings.

The scallop symbol shall be used in accordance with IEEE Std 315 and IEEE Std 315A for the development of windings.

<sup>j</sup>The nameplate shall state: “Contains no detectable level of PCB (less than 2 PPM) at the time of manufacture.”

<sup>k</sup>The nameplate shall state when the transformer is suitable for step-up operation.

<sup>l</sup>The maximum value of primary voltage as indicated in 4.1.6.1.

<sup>m</sup>The following tank, pressure, and liquid data for transformers larger than 500 kVA shall be provided:



- a) Maximum operating pressures of liquid preservation system \_\_\_\_\_ kPa (lbf/in<sup>2</sup>) positive and \_\_\_\_\_ kPa (lbf/in<sup>2</sup>) negative.
- b) Tank designed for \_\_\_ kPa (lbf/in<sup>2</sup>) vacuum filling. The manufacturer shall identify any portion of the transformer that cannot withstand the stated vacuum level (i.e., conservator, LTC boards, radiators).
- c) Liquid level below top surface of the highest point of the highest manhole flange at 25 °C \_\_\_\_\_ mm (in). Liquid level changes \_\_\_\_\_ mm (in) per 10 °C change in liquid temperature. (This applies only to transformers that have a gas cushion above the liquid in the transformer.)
- d) The volume of insulating liquid, in liters (gallons), and type shall be shown for the main tank and for each liquid-filled compartment.

<sup>n</sup>The nameplate of transformers that must comply with 10 CFR Part 431 shall include the statement (“DOE Compliant”) when the transformer is to be used in the United States or one of its protectorates or territories. Transformers that must meet this Code of Federal Regulation are defined in 10 CFR 431.192.

**5.12.3 Schematic representation**

Windings shall be represented as shown in Table 7 and Table 8.

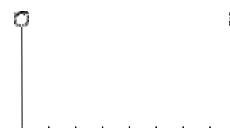
**Table 7—Designation of voltage ratings of single-phase windings (schematic representation)**

Identifi- cation	Nomenclature	Nameplate marking	Typical winding diagram	Condensed usage guide
(1)(a)	E	34 500		E <i>shall</i> indicate a winding of E volts that is suitable for Δ connection on an E volt system.
(1)(b)	E/E <sub>1</sub> Y	2400/4160Y		E/E <sub>1</sub> Y <i>shall</i> indicate a winding of E volts that is suitable for Δ connection on an E volt system, or for Y connection on an E <sub>1</sub> volt system.
(1)(c)	E/E <sub>1</sub> GrdY	39 840/69 000GrdY		E/E <sub>1</sub> GrdY <i>shall</i> indicate a winding of E volts having reduced insulation that is suitable for Δ connection on an E volt system, or Y connection on an E <sub>1</sub> volt system, transformer neutral effectively grounded.

(Table continues)

**Table 7—Designation of voltage ratings of single-phase windings  
(schematic representation) (continued)**

Identification	Nomenclature	Nameplate marking	Typical winding diagram	Condensed usage guide
(1)(d)	$E_1$ GrdY/E	12 470GrdY/7200		$E_1$ GrdY/E shall indicate a winding of E volts with reduced insulation at the neutral end. The neutral end may be connected directly to the tank for Y or for single-phase operation on an $E_1$ volt system, provided the neutral end of the winding is effectively grounded.
(1)(e)	E/2E	120/240, 240/480		E/2E shall indicate a winding; the sections of which can be connected in parallel for operation at E volts, or which can be connected in series for operation at 2E volts, or connected in series with a center terminal for three-wire operation at 2E volts between the extreme terminals and E volts between the center terminal and each of the extreme terminals.
(1)(f)	2E/E	240/120		2E/E shall indicate a winding for 2E volts, two-wire full kilovoltamperes between extreme terminals; or for 2E/E volts three-wire service with 1/2 kVA available only, from midpoint to each extreme terminal.
(1)(g)	$V \times V_1$	240 × 480 2400/4160Y × 4800/8320Y		$V \times V_1$ shall indicate a winding for parallel or series operation only but not suitable for three-wire service.
<p>NOTE 1—E is line-to-neutral voltage of a Y winding or line-to-line voltage of a <math>\Delta</math> winding.</p> <p>NOTE 2—<math>E_1</math> is <math>\sqrt{3}E</math>.</p> <p>NOTE 3—Additional subscripts, H, X, and Y (when used) identify high-voltage, low-voltage, and tertiary-voltage windings.</p>				

**Table 8—Designation of voltage ratings of three-phase windings (schematic representation)**

Identification	Nomenclature	Nameplate marking	Typical winding diagram	Condensed usage guide
(2)(a)	E	2400		E shall indicate a winding that is permanently Δ connected for operation on an E volt system.
(2)(b)	E <sub>1</sub> Y	4160Y		E <sub>1</sub> Y shall indicate a winding that is permanently Y-connected without a neutral brought out (isolated) for operation on an E <sub>1</sub> volt system.
(2)(c)	E <sub>1</sub> Y/E	4160Y/2400		E <sub>1</sub> Y/E shall indicate a winding that is permanently Y-connected with a fully insulated neutral brought out for operation on an E <sub>1</sub> volt system, with E volts available from line to neutral.
(2)(d)	E/E <sub>1</sub> Y	2400/4160Y		E/E <sub>1</sub> Y shall indicate a winding that may be Δ-connected for operation on an E volt system, or may be Y-connected without a neutral brought out (isolated) for operation on an E <sub>1</sub> volt system.
(2)(e)	E/E <sub>1</sub> Y/E	2400/4160Y/2400		E/E <sub>1</sub> Y/E shall indicate a winding that may be Δ-connected for operation on an E volt system, or may be Y-connected with a fully insulated neutral brought out for operation on an E <sub>1</sub> volt system with E volts available from line to neutral.
(2)(f)	E <sub>1</sub> GrdY/E	69 000GrdY/39 840		E <sub>1</sub> GrdY/E shall indicate a winding with reduced insulation and permanently Y-connected, with a neutral brought out and effectively grounded for operation on an E <sub>1</sub> volt system with E volts available from line to neutral.
(2)(g)	E/E <sub>1</sub> GrdY/E	39 840/69 000GrdY/39 840		E/E <sub>1</sub> GrdY/E shall indicate a winding having reduced insulation, which may be Δ-connected for operation on an E volt system; or may be connected Y with a neutral brought out and effectively grounded for operation on an E <sub>1</sub> volt system with E volts available from line to neutral.
(2)(h)	V × V <sub>1</sub>	7200 × 14 400		V × V <sub>1</sub> shall indicate a winding, the sections of which may be connected in parallel to obtain one of the voltage ratings (as defined in a–g) of V, or may be connected in series to obtain one of the voltage ratings (as defined in a–g) of V <sub>1</sub> . Winding are permanently Δ- or Y-connected.

## 6. Construction

### 6.1 Bushings

Transformers shall be equipped with bushings with an insulation level no less than that of the winding terminal to which they are connected, unless otherwise specified.

Bushings for use in transformers shall have impulse and low-frequency insulation levels as listed in Table 9 and IEEE Std C57.19.01 or IEEE Std C57.19.04.

Transformers using bushings that have dimensions in accordance with IEEE Std C57.19.01 or IEEE Std C57.19.04 shall have bushing mounting holes that are adequate to accommodate the maximum “P” dimensions for those bushings, as shown in the applicable tables.

### 6.2 Transformer accessories

Specific information on accessories is contained in the standards applying to particular types of transformers.

### 6.3 Bushing current transformers

Bushing current transformers used with bushings having dimensions in accordance with IEEE Std C57.19.01 or IEEE Std C57.19.04 shall have an inside diameter to accommodate the maximum “D” dimensions for those bushings, as shown in the applicable tables.

**Table 9—Electrical insulation characteristics of transformer bushings (applies only to bushings 34.5 kV and below not listed in IEEE Std C57.19.01 or IEEE Std C57.19.04)**

Outdoor bushing							Indoor bushings <sup>a</sup>		
Power transformers <sup>b</sup>					Distribution transformers <sup>b</sup>				
System voltage <sup>c</sup> (kV)	Minimum creepage distance mm/(in)	Rated frequency withstand		Impulse full wave dry withstand (kV) (1.2/50 μs)	Rated frequency withstand		Impulse full wave dry withstand (kV) (1.2/50 μs)	Rated frequency withstand 1 min dry (kV)	Impulse full wave dry withstand (kV) (1.2/50 μs)
		1 min dry (kV)	10 s wet (kV)		1 min dry (kV)	10 s wet (kV)			
1.2	—	—	—	—	10	6	30	—	—
2.5	—	21	20	60	15	13	45	20	45
5.0	—	27	24	75	21	20	60	24	60
8.7	—	—	—	—	27	24	75	30	75
8.7	178/(7)	35	30	95	—	—	—	—	—
15.0	—	—	—	—	35	30	95	50 <sup>d</sup>	110 <sup>d</sup>
18.0	—	—	—	—	42	36	125	—	—
25.0	—	—	—	—	—	—	—	60	150
34.5	—	—	—	—	—	—	—	80	200

<sup>a</sup>Indoor bushings are those intended for use on indoor transformers. Indoor bushing test values do not apply to bushings used primarily for mechanical protection of insulated cable leads. Wet test values are not assigned to indoor bushings.

<sup>b</sup>Power transformers indicate transformers that are covered under the power transformer product standard IEEE Std C57.12.10™ [B31] and distribution transformers indicate transformers that are covered under the various distribution product standards, such as IEEE Std C57.12.20™ [B32], IEEE Std C57.12.38™ [B37], IEEE Std C57.12.34™ [B35], or IEEE Std C57.12.36™ [B36].

<sup>c</sup>Nominal system voltage values given above are used merely as reference numbers and do not necessarily imply a relation to specific operating voltages.

<sup>d</sup>Small indoor transformers *may* be supplied with bushings for a dry withstand test of 38 kV and an impulse test of 95 kV.

## 6.4 Thermometer wells

Unless otherwise specified in the standard applying to the particular type of transformer, dimensions for thermometer wells shall be as shown in Figure 4.

The thermometer well shall be positioned in such a way that it is at least 25.4 mm (1 in) below the liquid level at minimum operating temperature (either –20 °C or as specified by the user).

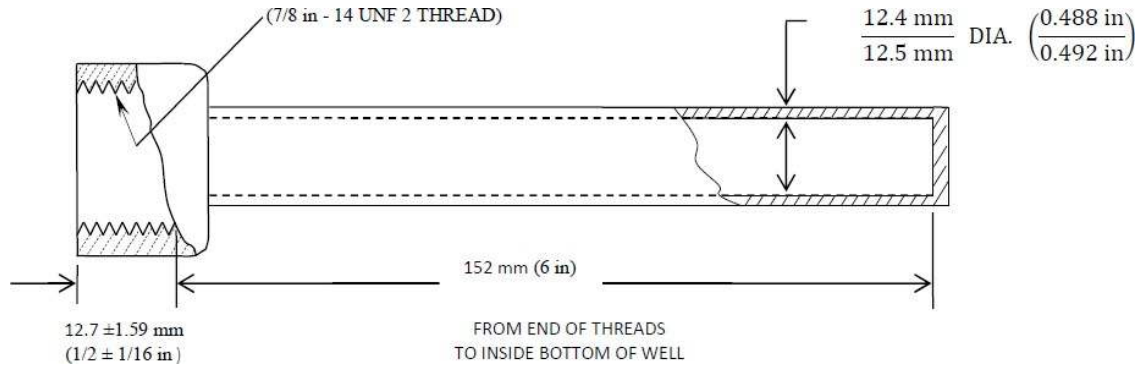

Figure 4—Dimension of thermometer well

## 6.5 Tank pressure requirements

### 6.5.1 Maximum under rated conditions

Tank pressure under rated conditions for sealed transformers shall not exceed two atmospheres (203 kPa) absolute pressure unless requirements of applicable sections of the ASME Boiler and Pressure Vessel Code (BPVC) are met.<sup>14</sup>

### 6.5.2 Limits and tests

Specific pressure limits and tests are included in standards applying to particular types of transformers.

## 6.6 Liquid insulation system

### 6.6.1 Insulating liquids

Transformers shall be filled with a suitable insulating liquid such as the following:

- Mineral oil.* New, unused mineral oil shall meet the requirements of ASTM D3487.  
NOTE—IEEE Std C57.106™ [B18] provides information concerning the acceptance and maintenance of mineral oil, including dielectric test breakdown criteria according to oil application, age, and test method.
- Less-flammable hydrocarbon fluid.* New, unused less-flammable hydrocarbon fluid shall meet the requirements of ASTM D5222.  
NOTE—IEEE Std C57.121™ [B26] provides information concerning the acceptance and maintenance of less-flammable fluid in transformers.
- Silicone insulating fluid.* New, unused silicone insulating fluid shall meet the requirements of ASTM D2225.  
NOTE—IEEE Std C57.111™ [B21] provides information concerning the acceptance and maintenance of silicone insulating fluid in transformers.
- Natural ester insulating liquid.* New, unused natural ester insulating liquid shall meet the requirements of ASTM D6871.  
NOTE—IEEE Std C57.147™ [B27] provides information concerning the acceptance and maintenance of less-flammable natural ester insulating liquid in transformers.

<sup>14</sup>Two atmosphere absolute pressure = 203 kPa or 29.4 psia.

## 6.6.2 Insulating liquid preservation

Transformers shall be equipped with an insulating liquid preservation system such as the following:

- a) Sealed tank
- b) Gas-insulating liquid seal
- c) Conservator
- d) Conservator/diaphragm

NOTE—Various insulating liquid (oil) preservation systems are described and defined in IEEE Std C57.12.80.

## 6.6.3 Nitrogen inert-gas pressure system

Nitrogen for use with inert-gas-protected transformers shall be in accordance with ASTM D1933, Type III. Nitrogen shall be supplied in 5.66 m<sup>3</sup> (200 ft<sup>3</sup>) cylinders equipped with Connection No. 580 of CGA V-1. The filling pressure shall be 15.2 MPa (2200 lbf/in<sup>2</sup>) at 21.1 °C (70 °F).

## 6.7 Grounding

### 6.7.1 Transformer grounding

Transformer grounding facilities shall be furnished in accordance with the standards for particular types of transformers.

### 6.7.2 Grounding of core

The transformer core shall be grounded to the transformer tank for electrostatic purposes.

#### 6.7.2.1 Grounding of wound cores

In transformers with wound cores, five-legged three phase and three-legged single phase, low-voltage/high-voltage winding construction and a high-voltage winding greater than or equal to 25 kV (15 kV to ground), the transformer core shall be properly grounded to the tank. Said grounding may be from the inside or outside of the core as long as there are not two ground locations in the same core. In order to validate that the core will not be susceptible to partial discharges during normal operation, a design test, specific for this type of wound core transformer, is specified in Table 17, and the procedure is described in IEEE Std C57.12.90-2021 subclause 10.7.7.

NOTE—Partial discharge (PD) generation in transformers can possibly occur due to various other factors which may be internal and/or external to the transformer and the capacitive coupling of the core is one of these factors. Partial discharge issues arising from capacitive coupling between the winding and core can be minimized via specific placement of the core ground. Any ground location other than the very inside lamination *may* require a ground shield at the inside of the core. Any ground location other than the outside *may* require insulation between adjacent cores.

## 6.8 Minimum external clearances of transformer live parts

Table 10 describes the minimum external clearances between transformer live parts to ground and to different phases. In the establishment of these clearances, it was recognized that bushing ends normally have rounded electrode shapes. It is also assumed that conductor clamps would be suitably shaped so that they would not reduce the withstand strengths, and the arrangement of the incoming conductors would not reduce the effective clearances provided by the transformer bushing. In other words, the clearances were established based on electrostatic fields that were usually not divergent.

Where adequate previous experience has indicated that smaller clearances are acceptable, the smaller clearances may be applied when agreed on by both the user and the manufacturer. The clearances in this clause are for in service conditions. Factory test conditions may require larger clearances than those defined here. Minimum external clearances shall comply with Table 10 except where suitable grading of local stresses may allow smaller clearances.

The nominal clearance values indicated are subject to normal manufacturing tolerances. Normal manufacturing tolerances should not significantly increase the likelihood of a flashover because the clearances listed in Table 10 are conservative.

-----

**Table 10—Minimum external clearances of transformer live parts**

Maximum system voltage (kV rms)	Nominal system voltage (kV rms)	Winding line-end BIL (kV crest) (from Table 3 and Table 4)	BSL (kV crest) (from Table 5)	Minimum clearance between live parts of one phase and ground, mm (in) <sup>a</sup>	Minimum clearance between live parts of different phases of the same voltage, mm (in) <sup>a</sup>
Col 1	Col 2	Col 3	Col 4	Col 5	Col 6
1.5	1.2	30	—	25 (1)	25 (1)
1.5	1.2	45	—	51 (2)	51 (2)
3.5	2.5	45	—	51 (2)	51 (2)
3.5	2.5	60	—	64 (2.5)	64 (2.5)
6.9	5.0	60	—	64 (2.5)	64 (2.5)
6.9	5.0	75	—	89 (3.5)	102 (4)
11.0	8.7	75	—	89 (3.5)	102 (4)
11.0	8.7	95	—	127 (5)	140 (5.5)
17.0	15.0	95	—	127 (5)	140 (5.5)
17.0	15.0	110	—	140 (5.5)	152 (6)
26.0	25.0	125	—	165 (6.5) <sup>b</sup>	178 (7) <sup>b</sup>
26.0	25.0	150	—	203 (8)	229 (9)
36.0	34.5	125	—	165 (6.5)	178 (7)
36.0	34.5	150	—	203 (8)	229 (9)
36.0	34.5	200	—	305 (12)	330 (13)
48.0	46.0	200	—	305 (12)	330 (13)
48.0	46.0	250	—	381 (15)	432 (17)
72.5	69.0	250	—	381 (15)	432 (17)
72.5	69.0	350	—	584 (23)	635 (25)
121	115.0	350	—	584 (23)	635 (25)
121	115.0	450	—	762 (30)	838 (33)
121	115.0	550	—	940 (37)	1041 (41)
145	138.0	450	—	762 (30)	838 (33)
145	138.0	550	—	940 (37)	1041 (41)
145	138.0	650	—	1118 (44)	1245 (49)
169	161.0	550	—	940 (37)	1041 (41)
169	161.0	650	—	1118 (44)	1245 (49)
169	161.0	750	—	1321 (52)	1448 (57)
169	161.0	825	—	1448 (57)	1600 (63)
242	230.0	650	—	1118 (44)	1245 (49)
242	230.0	750	—	1321 (52)	1448 (57)
242	230.0	825	—	1448 (57)	1600 (63)
242	230.0	900	—	1600 (63)	1778 (70)
362	345.0	900	745	1829 (72) <sup>c</sup>	2337 (92) <sup>d</sup>
362	345.0	1050	870	2210 (87) <sup>c</sup>	2870 (113) <sup>d</sup>
362	345.0	1175	975	2565 (101) <sup>c</sup>	3429 (135) <sup>d</sup>
550	500.0	1425	1080	2946 (116) <sup>c</sup>	3988 (157) <sup>d</sup>
550	500.0	1550	1290	3785 (149) <sup>c</sup>	5461 (215) <sup>d</sup>
550	500.0	1675	1390	4216 (166) <sup>c</sup>	6198 (244) <sup>d</sup>
765	735.0	1950	1550	5004 (197) <sup>c</sup>	NOTE 2
765	735.0	1950	1620	5385 (212) <sup>c</sup>	NOTE 2
765	735.0	2050	1700	5842 (230) <sup>c</sup>	NOTE 2
800	765.0	1950	1620	5385 (212) <sup>c</sup>	NOTE 2
800	765.0	2050	1700	5842 (230) <sup>c</sup>	NOTE 2
1200	1100.0	2250	1870	6934 (273) <sup>c</sup>	NOTE 2

NOTE 1—The above clearances are the minimum recommended to ensure satisfactory operation in service considering only the effects of the electrical stress. Clearances at 230 kV and below in the table are based on lightning impulse. Clearances above 230 kV in the table are based on switching impulse.

NOTE 2—Transformers at nominal system voltages of 735 kV, 765 kV, and 1100 kV are normally single phase so that clearances between live parts of different phases is not an issue.

<sup>a</sup> The external clearances given are for transformers intended for operation at altitudes of 1000 m (3300 ft) or less. Refer to 4.3.2 for operation at altitudes in excess of 1000 m (3300 ft).

<sup>b</sup> Note that IEEE C57.12.34-2015 [B35] specifies a phase-to-ground clearance of 5.75 in (146 mm) and phase-to-phase clearance of 6.25 in (159 mm) for 125 kV BIL, 25 kV nominal system voltage. IEEE C57.12.38-2014 [B37] specifies a phase-to-ground clearance of 5.75 in (146 mm) for 125 kV BIL, 25 kV nominal system voltage. The smaller clearances are acceptable since the bushings are always located within a metal enclosure and are not subject to the same conditions that occur with bushings exposed to the elements.

<sup>c</sup>Phase-to-ground switching impulse clearances may be calculated using Equation (2) and Equation (3). The values in this table were determined using a gap factor of 1.3, probability of withstand of 90%, and coefficient of variation of 7%. IEEE Std 1313.2™ [B7] and IEEE Std 1427 contain more information on these equations.

$$S = \frac{8}{\frac{k_g \times 3400}{\text{CFO}} - 1} \quad (2)$$

$$\text{BIL} = \text{CFO} \times \left( 1 - 1.28 \times \frac{\sigma_f}{\text{CFO}} \right) \quad (3)$$

where

- S is the strike distance in meters
- $k_g$  is the gap factor
- CFO is the critical flashover voltage in kV
- BIL is the basic lightning impulse insulation level in kV
- $\frac{\sigma_f}{\text{CFO}}$  is the coefficient of variation

<sup>d</sup> Phase-to-phase switching impulse clearances may be calculated using Equation (4) and the equations in Note c. The values in this table were determined using a phase-to-phase gap factor of 1.4, probability of withstand of 90%, and coefficient of variation of 5%. IEEE Std 1427 describes in greater detail the application of these calculations.

$$\text{CFO}_{ph-ph} = 1.068 \times \text{BSL}_{ph-grd} \times R_{ph-ph} \quad (4)$$

where

- $\text{CFO}_{ph-ph}$  is the critical flashover voltage phase-to-phase in kV
- $\text{BSL}_{ph-grd}$  is the basic switching impulse insulation level phase-to-ground in kV
- $R_{ph-ph}$  is a dimensionless ratio associating the phase-ground BSL to the phase-phase BSL, taken from IEEE Std 1427 Table 6

### CAUTION

If there is risk that these clearances will be effectively reduced by the intrusion of birds or animals, the user should specify increased clearances between bushings. This is most important at lower system voltages where clearances between bushings are small. In the case where bushings terminate in a closed junction box for connection to cables, intrusion by birds and animals is unlikely; therefore, the above minimum clearances should be adequate.

## 7. Short-circuit characteristics

### 7.1 Requirements

#### 7.1.1 General

Liquid-immersed transformers shall be designed and constructed to withstand the mechanical and thermal stresses produced by external short circuits under the conditions specified in 7.1.3, 7.1.4, and 7.1.5. The external short circuits shall include three-phase, single line-to-ground, double line-to-ground, and line-to-line faults on any one set of terminals at a time. Multi-winding transformers shall be considered to have system fault power supplied at no more than two sets of unfaulted terminals rated greater than 35% of the terminal kVA of the highest capacity winding. For other fault conditions, the requirements shall be specified by those responsible for the application of the transformer.

Short-circuit withstand capability can be adversely affected by the cumulative effects of repeated mechanical and thermal overstressing produced by short circuits and loads above the nameplate rating. It is not feasible to continuously monitor and quantitatively evaluate the degrading effects of such duty; short-circuit tests, when required, should be performed prior to placing transformer(s) in service.

The intention here is not that every transformer be short-circuit tested to demonstrate adequate construction.

When specified, short-circuit tests shall be performed as described in IEEE Std C57.12.90.

#### 7.1.2 Transformer categories

Four categories for the rating of transformers are recognized, as shown in Table 11.

**Table 11—Category of transformer ratings**

Category	Single phase (kVA)	Three phase (kVA)
I <sup>a</sup>	5 to 500	15 to 500
II	501 to 1667	501 to 5000
III	1668 to 10 000	5001 to 30 000
IV	Above 10 000	Above 30 000
NOTE—All kVA ratings listed are minimum nameplate kVA for the principal windings.		

<sup>a</sup>Autotransformers with equivalent two-winding kVA of 500 or less, which are manufactured as distribution transformers in accordance with IEEE Std C57.12.20 [B32], IEEE Std C57.12.23™ [B33], IEEE Std C57.12.24™ [B34], IEEE Std C57.12.34 [B35], IEEE Std C57.12.36 [B36], IEEE Std C57.12.38 [B37], or IEEE Std C57.12.40™ [B38] shall be included in Category I, even though their nameplate kVA may exceed 500.

#### 7.1.3 Short-circuit current duration

##### 7.1.3.1 General

The short-circuit current duration that a transformer shall withstand is defined in 7.1.3.1. The mechanical behavior of the transformer shall be ascertained by short-circuit tests conducted per IEEE Std C57.12.90; the test duration shall be as defined in 7.1.3.2. The short-circuit thermal behavior of the transformer shall be determined by calculations per 7.4; the minimum short-circuit duration applicable for these calculations shall be those defined in 7.1.3.1.

For Category I transformers, the duration of the short circuit *shall* be determined by Equation (5).

For Category II, III, and IV units, the duration of the short-circuit current as defined in 7.1.4 is limited to 2 s, unless otherwise specified by the user.

When used on circuits having reclosing features, transformers in all categories *shall* be capable of withstanding the resulting successive short circuits without cooling to normal operating temperatures between successive occurrence of the short circuit, provided that the accumulated duration of the short circuit does not exceed the maximum duration permitted for single short circuits as defined in 7.1.3.1.

For currents between rated current and maximum short-circuit current, the allowable time duration *should* be obtained by consulting the manufacturer.

IEEE Std C57.12.90 defines a procedure by which the mechanical capability of a transformer to withstand short-circuit stresses *may* be demonstrated. The prescribed tests are not designed to verify thermal performance. Conformance to short-circuit thermal requirements *shall* be by calculation in accordance with 7.4.

### 7.1.3.2 Duration of short-circuit tests

When short-circuit tests are performed, the duration of each test *shall* be 0.25 s except that one test satisfying the symmetrical current requirement *shall* be made for a longer duration on Category I, II, and III transformers. The duration of the long test in each case *shall* be as shown in Equation (5).

Category I:

$$t = \frac{1250}{I^2} \quad (5)$$

where

$t$  is duration (s)  
 $I$  is symmetrical short-circuit current in multiples of normal base current (see 7.1.5.1)

Category II:  $t$  is 1.0 s

Category III:  $t$  is 0.5 s

NOTE—There is no long-duration test for Category IV transformers.

For special applications when longer fault durations are common in service, special long-duration tests *should* be specified at purchase. When making consecutive tests without allowing time for winding cooling, care *should* be exercised to avoid exceeding temperature limits (specified in 7.3.5) for transformers under short-circuit conditions.

### 7.1.4 Short-circuit current magnitude

#### 7.1.4.1 Category I

The symmetrical short-circuit current *shall* be calculated using transformer impedance only, except that the maximum symmetrical current magnitudes *shall* not exceed the values listed in Table 12.

**Table 12—Distribution transformer short-circuit withstand capability**

Single phase (kVA)	Three phase (kVA)	Withstand capability <sup>a</sup> per unit of base current (symmetrical)
5 to 25	15 to 75	40
37.5 to 100	112.5 to 300	35
167 to 500	500	25

<sup>a</sup>Two-winding distribution transformers with secondaries rated above 600 V should be designed to withstand short circuits limited only by the impedance of the transformer. Autotransformers having nameplate kVA greater than 500 that are built as distribution transformers in accordance with IEEE Std C57.12.20 [B32], IEEE Std C57.12.23 [B33], IEEE Std C57.12.24 [B34], IEEE Std C57.12.34 [B35], IEEE Std C57.12.36 [B36], IEEE Std C57.12.38 [B37], or IEEE Std C57.12.40 [B38] shall have withstand capabilities of 25 per unit of base current (symmetrical).

### 7.1.4.2 Category II

The symmetrical short-circuit current *shall* be calculated using transformer impedance only.

### 7.1.4.3 Categories III and IV

The symmetrical short-circuit current shall be calculated using transformer impedance plus system impedance, as specified by the transformer user. When system impedance is not specified, data from 7.1.5.3 shall be used.

### 7.1.4.4 Stabilizing windings

Stabilizing windings in three-phase transformers ( $\Delta$ -connected windings with no external terminals) shall be capable of withstanding the current resulting from any of the system faults specified in 7.1.1, recognizing the system grounding conditions. Appropriate stabilizing winding kVA, voltage, and impedance shall be provided.

## 7.1.5 Short-circuit current calculations

### 7.1.5.1 Symmetrical current (two-winding transformers)

It should be noted that for multi-winding transformers and autotransformers, the required rms value of symmetrical current in each winding shall be determined by calculation as shown in Equation (6) and Equation (7), based on applicable system conditions and fault types.

$$I_{SC} = \frac{I_R}{Z_T + Z_S} \quad (6)$$

$$I = \frac{I_{SC}}{I_R} \quad (7)$$

where

- $I$  is the symmetrical short circuit current in multiple of normal base
- $I_{SC}$  symmetrical short circuit current (A, rms)
- $I_R$  is the rated current on the given tap connection (A, rms)
- $Z_T$  is the transformer impedance on the given tap connection, in per unit on the same apparent power base as  $I_R$
- $Z_S$  is the impedance of the system or permanently connected apparatus, in per unit on the same apparent power base as  $I_R$

### 7.1.5.2 Asymmetrical current

The first-cycle asymmetrical peak current that the transformer is required to withstand *shall* be determined as shown in Equation (8) and Equation (9):

$$I_{SC} (\text{pk asym}) = KI_{SC} \quad (8)$$

$$K = \left\{ 1 + \left[ e^{-\left(\frac{\varphi + \pi}{2}\right) \frac{x}{r}} \right] \sin \varphi \right\} 2 \quad (9)$$

where

- $\varphi$  is arc tan ( $x/r$ ) (radians)
- $e$  is the base of natural logarithm
- $x/r$  is the ratio of effective ac reactance to resistance, both in ohms, in the total impedance that limits the fault current for the transformer connections when the short circuit occurs  
(When the system impedance is included in the fault-current calculation, the  $x/r$  ratio of the external impedance shall be assumed equal to that of the transformer, when not specified. Since the system  $x/r$  is much smaller than the transformer  $x/r$ , the assumed system ratio will have little impact on the asymmetrical peak calculation. The effect it will have is to make the design of the transformer slightly more conservative.)

Values of  $K$  are given in Table 13.

### 7.1.5.3 System characteristics

For Categories III and IV, the characteristics of the system on each set of terminals of the transformer (system fault capacity and the ratio of  $X_0/X_1$ ) should be specified. For terminals connected to rotating machines, the impedance of the connected equipment should be specified. In lieu of specified system fault capacities and rotating machine impedances, values shall be selected for each source from Table 14 and Table 15. In lieu of a specified  $X_0/X_1$  ratio, a value of 1.0 shall be used.

In establishing the fault values shown in Table 14, consideration was given to currently available maximum circuit breaker ratings and existing fault levels determined from user surveys. It is recognized that some systems will present fault levels that exceed these levels. If additional margin is desired, users may specify pre-fault voltage conditions (e.g., 1.05 p.u.) or an infinite bus. For low impedance transformers, specifying an infinite bus may increase the cost of the transformer significantly.

**Table 13—Values of  $K$**

$r/x$	$x/r$	$K$
0.001	1000.00	2.824
0.002	500.00	2.820
0.003	333.00	2.815
0.004	250.00	2.811
0.005	200.00	2.806
0.006	167.00	2.802
0.007	143.00	2.798
0.008	125.00	2.793
0.009	111.00	2.789
0.010	100.00	2.785
0.020	50.00	2.743
0.030	33.30	2.702
0.040	25.00	2.662
0.050	20.00	2.624
0.060	16.70	2.588
0.070	14.30	2.552
0.080	12.50	2.518
0.090	11.10	2.484
0.100	10.00	2.452
0.200	5.00	2.184
0.300	3.33	1.990
0.400	2.50	1.849
0.500	2.00	1.746
0.600	1.67	1.669
0.700	1.43	1.611
0.800	1.25	1.568
0.900	1.11	1.534
1.000	1.00	1.509

NOTE—The expression of  $K$  is an approximation. The tabulated values of  $K$  given in Table 13 are calculated from this approximation and are accurate to within 0.7% of the values calculated by exact methods.

**Table 14—Short-circuit apparent power of the system to be used unless otherwise specified**

Maximum system voltage (ANSI C84.1) (kV rms)	Nominal system voltage (kV rms)	System fault capacity (based on maximum system voltage)	
		(kA rms)	(MVA)
Below 48.3	Below 46	63	—
48.3	46	63	5270
72.5	69	63	7910
121.0	115	80	16 770
145.0	138	80	20 090
169.0	161	80	23 420
242.0	230	80	33 530
362.0	345	80	50 160
550.0	500	80	76 210
765.0	735	80	106 000
800.0	765	80	110 850

**Table 15—Subtransient reactance of three-phase synchronous machines<sup>a</sup>**

Type of machine	Most common reactance per unit	Subtransient reactance range per unit
Two-pole turbine generator	0.10	0.07 to 0.20
Four-pole turbine generator	0.14	0.12 to 0.21
Salient pole generators and motors with dampers	0.20	0.13 to 0.32
Salient pole generators without dampers	0.30	0.20 to 0.50
Condensers, air cooled	0.27	0.19 to 0.30
Condensers, hydrogen cooled	0.32	0.23 to 0.36

<sup>a</sup>Assumptions of rotating machine impedances *should* be defined by the transformer manufacturer.

#### 7.1.5.4 Present limitations

Conventional transformer materials and constructions have inherent short-circuit withstand capability limitations. An example is the tensile withstand capability of annealed copper, which places a limit on the permissible hoop tensile stress in the outer winding of a core form transformer. New materials and construction techniques have been, and will continue to be, developed to extend the withstand capability limitations.

However, in certain circumstances, it may not be possible to provide the requisite strength in the transformer. In such situations, it would become necessary to limit the fault current with additional impedance external to the transformer windings. For example, it may not be possible to design a reduced-capacity auxiliary winding

to withstand a fault directly on its terminals. When the current requirements of 7.1.4 cannot be met, limits of fault-current capability of the transformer shall be specified by the manufacturer in the proposal and shall be identified on the transformer nameplate.

For distribution transformers, the short-circuit withstand capability limits of Table 12 have been accepted as being representative for conventional materials and constructions.

### 7.1.5.5 Application conditions requiring special consideration

The following situations affecting fault-current magnitude, duration, or frequency of occurrence require special consideration and should be identified in transformer specifications:

- a) Regulating transformers with extremely low impedance that depend on the impedance of directly connected apparatus to limit fault currents.
- b) Generator transformers susceptible to excessive overcurrents produced by connection of the generator to the system out of synchronism.
- c) Transformer terminals connected to rotating machines (such as motors or synchronous condensers) that can act as generators to feed current into the transformer under system fault conditions.
- d) Operating voltage that is higher than rated maintained at the unfaulted terminal(s) during a fault condition.
- e) Frequent overcurrents arising from the method of operation or the particular application (for example, furnace transformers, starting taps, applications using grounding switches for relay purposes, and traction feeding transformers).
- f) Station auxiliary transformers or main generator step-up transformers directly connected to a generator that may be subjected to prolonged duration terminal faults as a result of the inability to remove the voltage source quickly. See IEEE Std C57.116™ [B24] for more information.
- g) Faults initiated by circuit breakers that may, under certain conditions, cause fault current in excess of those calculated in accordance with this clause.

## 7.2 Components

Transformer components such as leads, bushings, LTCs, de-energized tap-changers, and current transformers that carry current continuously *shall* comply with all the requirements of 7.1.3 and 7.1.4. However, when not explicitly specified, LTCs are not required to change taps successfully under short-circuit conditions.

## 7.3 Base kilovoltamperes

### 7.3.1 Base kVA of a winding

This is the self-cooled rating of a winding as specified by the nameplate or as determined in accordance with Table 16.

For a transformer without a self-cooled rating, the applicable multiplying factor from Table 16 *shall* be applied to the maximum nameplate kVA rating to obtain the equivalent base kVA rating.

**Table 16—Base current calculation factors**

Type of transformer	Multiplying factor
Water-cooled (ONWF)	1.0
Natural or forced liquid-cooled with either forced-air cooled or forced-water cooled (ONAF, OFAF, ODAF and OFWF, ODWF), and similarly for designations of other insulating fluids	0.60

### 7.3.2 Base current of windings without autotransformer connections

For transformers with two or more windings without autotransformer connections, the base current of a winding is obtained by dividing the base kVA of the winding by the rated kV of the winding on a per-phase basis.

### 7.3.3 Base current of windings with autotransformer connections

For transformers with two or more windings, including one or more autotransformer connections, the base current and base kVA of any winding other than the series and common windings are determined as described in 7.3.2.

The base current of the series winding is equal to the base kVA per phase at the series line terminal, H, divided by the minimum full capacity tap voltage at the series line terminal, H, in kV line to neutral.

The base current of the common winding is equal to the line current at the common winding terminal, X, minus the line current at the series winding terminal, H, under loading conditions resulting in the maximum phasor difference. All conditions of simultaneous loading authorized by the nameplate *should* be considered to obtain the maximum value. Base currents are calculated based on self-cooled loading conditions or equivalent (use multiplying factors).

### 7.3.4 Base current in windings of a regulating transformer

The base current for each winding of a regulating transformer is the maximum current that can occur in that winding for any loading condition authorized by the nameplate. Base currents are calculated based on self-cooled loading conditions or equivalent (use multiplying factors). It *should* be noted that these base current definitions are applicable only to windings designed for connection to load.

### 7.3.5 Temperature limits of transformers for short-circuit conditions

The temperature of the conductor material in the windings of transformers under the short-circuit conditions specified in 7.1.1 through 7.1.4, as calculated by methods described in 7.1.4, *shall* not exceed 250 °C for copper conductor or 200 °C for EC (electrical conductor grade) aluminum conductor. A maximum temperature of 250 °C *shall* be allowed for aluminum alloys that have resistance to annealing properties at 250 °C equivalent to EC aluminum at 200 °C, or for applications of EC aluminum where the characteristics of the fully annealed material satisfy the mechanical requirements. In setting these temperature limits, the following factors were considered:

- a) Gas generation from insulating liquid or solid insulation
- b) Conductor annealing
- c) Insulation aging

## 7.4 Calculation of winding temperature during a short circuit

The final winding temperature,  $T_f$ , at the end of a short circuit of duration,  $t$ , shall be calculated as shown in Equation (10) through Equation (16), on the basis of all heat stored in the conductor material and its associated turn insulation. All temperatures are in degrees Celsius.

$$T_f = (T_k + T_s)m(1 + E + 0.6m) + T_s \quad (10)$$

$$m = \frac{W_s t}{C(T_k + T_s)} \quad (11)$$

$$E = E_r \left( \frac{T_k + T_f}{T_k + T_s} \right)^2 \quad (12)$$

$$W_s = \frac{W N^2 (T_k + T_s)}{M \left( \frac{T_k + T_s}{T_k + T_f} \right)} \quad (13)$$

where

- $t$  is the duration of the short circuit current in seconds
- $T_f$  is final winding temperature
- $T_k$  is 234.5 for copper  
is 225 for EC grade aluminum (the appropriate values for other grades may be used)
- $T_s$  is the starting temperature. It is equal to:
  - a) A 30 °C ambient temperature plus the average winding rise plus the manufacturer's recommended hottest-spot allowance, or
  - b) A 30 °C ambient temperature plus the limiting winding hottest-spot temperature rise specified for the appropriate type of transformer.

$C$  is the average thermal capacitance per kg of conductor material and its associated turn insulation ( $W \cdot s / ^\circ C$ ). It shall be determined by iteration from either of the following empirical equations: (14)

$$\left[ 384 + 0.0496(T_s + T_f) + 243 A_i A_c \right] \text{ for copper} \quad (14)$$

$$\left[ 893 + 0.220(T_s + T_f) + 794 A_i A_c \right] \text{ for aluminum} \quad (15)$$

- $A_i$  is the cross-sectional area of turn insulation in  $mm^2$
- $A_c$  is the cross-sectional area of conductor in  $mm^2$
- $e$  is the base of natural logarithm, 2.718
- $E$  is the per-unit eddy-current loss, based on resistance loss,  $W_s$ , at the starting temperature
- $E_r$  is the per-unit eddy-current loss at the reference temperature
- $T_r$  is the reference temperature, defined as 20 °C plus the rated average winding rise
- $W_s$  is the short-circuit resistance loss of the winding at the starting temperature of conductor material (W/kg)
- $W_r$  is the resistance loss of winding at rated current and reference temperature (W)
- $N$  is the ratio of symmetric short-circuit current magnitude to normal rated current
- $M$  is the mass of winding conductor (kg)

These equations are approximate formulas, and their use should be restricted to values of  $m = 0.6$  or less.

For values of  $m$  in excess of 0.6, the following more nearly exact formula *should* be used:

$$T_f = (T_k + T_s) \left[ \sqrt{e^{2m} + E(e^{2m} - 1)} - 1 \right] + T_s \quad (16)$$

### CAUTION

When applying the preceding equations for calculation, care shall be taken to assure consistent application of units for mass, weights, and cross-sectional areas. This will involve the variables  $W_s$ ,  $M$ ,  $C$ ,  $A_i$ , and  $A_c$ . Mixing of units between SI system and the U.S. customary units (in, lb) will yield incorrect results.

## 8. Testing and calculations

### 8.1 General

Unless otherwise specified, all tests *shall* be made in accordance with IEEE Std C57.12.90. Unless otherwise specified, tests *shall* be made at the factory or other approved testing facilities.

### 8.2 Routine, design, and other tests for transformers

Routine, design, and other tests *shall* be made in accordance with the requirements of Table 17. The sequence of tests listed in Table 17 does not imply the order in which these tests must be performed. Test sequence, when pertinent, is defined in IEEE Std C57.12.90.

#### 8.2.1 Routine tests

Routine tests *shall* be made on every transformer to verify that the product meets the design specifications.

#### 8.2.2 Design tests

Design tests *shall* be made on a transformer of new design to determine the adequacy of the design of a particular type, style, or model of transformer or its component parts. Design adequacy includes but is not limited to: meeting assigned ratings, operating satisfactorily under normal service condition or under special condition if specified, and compliance with appropriate standards of the industry. Design tests are made on representative transformers to substantiate the ratings assigned to all other transformers of basically the same design. Design tests are not intended to be used as a part of normal production. The applicable portion of these design tests *may* also be used to evaluate modifications of a previous design and to assure that performance has not been adversely affected. Test data from previous similar designs *may* be used for current designs, where appropriate. Once made, the tests need not be repeated unless the design is changed to modify performance.

#### 8.2.3 Other tests

Other tests are identified in individual product standards and *may* be specified by the purchaser in addition to routine tests. (Examples: impulse, insulation power factor, audible sound, temperature rise, short circuit.)

**Table 17—Routine, design, and other tests for liquid-immersed transformers**

Tests	Distribution transformers			Class I power transformers			Class II power transformers			Comments
	Routine	Design	Other	Routine	Design	Other	Routine	Design	Other	
<b>Performance</b>										
Resistance measurements of all windings on the rated voltage tap and at the tap extremes of the first unit of a new design	*	*		*			*			Resistance measurement is a <i>design</i> test for distribution transformers rated 2500 kVA and smaller and a <i>routine</i> test for distribution transformers rated greater than 2500 kVA.
Ratio tests on the rated voltage connection and on all tap-positions as listed on the nameplate	*			*			*			For LTC units, see 8.3.1. For multiple winding or dual voltage units, ratio tests shall be performed on all connections.
Polarity and phase relation tests on the rated voltage connection	*			*			*			
No-load losses and excitation current at <b>100%</b> of rated voltage and at rated power frequency on the rated voltage tap connection(s)	*			*			*			
No-load losses and excitation current at <b>110%</b> of rated voltage and at rated power frequency on the rated voltage tap connection(s)			*	*			*			
Impedance voltage and load loss at rated current and rated frequency on the rated voltage connection, and at the tap extremes of the first unit of a new design	*			*			*			These measurements shall be taken only at the rated voltage connection for a two-winding unit, and at all rated voltage connections for units with three or more windings. At least one test shall be performed at the minimum kVA rating and one test at the maximum kVA rating. The tested load loss of duplicate transformers shall be corrected to reference temperature by assuming the same stray and eddy loss as the design test transformer. For LTC units, see 8.3.2.
Operation tests of all devices	*			*			*			All electrical and electro-mechanical devices for controlling auxiliary devices such as fans, pumps, motors, LTCs, etc., shall be operated both in auto and manual mode for proper sequencing/staging and function.

Tests	Distribution transformers			Class I power transformers			Class II power transformers			Comments
	Routine	Design	Other	Routine	Design	Other	Routine	Design	Other	
Control (auxiliary) and cooling consumption losses			*			*	*			Power consumption (auxiliary/cooling) losses associated with fans and pumps shall be measured.
Zero-phase sequence impedance voltage and load loss on the rated tap connection			*		*		*			Zero-phase sequence impedance shall be performed when a neutral is brought out. This test is not applicable to single-phase, shell-form, or transformers with five-legged cores.
Temperature rise at minimum and maximum ratings of the first unit of a new design		*			*			*		
Temperature rise at minimum and maximum ratings, when temperature-rise tests are specified			*			*			*	
Dissolved gas in oil analysis			*			*	*			As a minimum, dissolved gas in oil analysis shall be performed on oil samples drawn before the start of all tests, and after the completion of all tests.
Audible sound level		*	*		*	*		*	*	See 8.2.5 for audible sound level requirements.
Short-circuit capability		*	*			*			*	Testing of large transformers may not be practical because of test facility limitations.
Telephone influence factor (TIF)			*							A test method for measuring TIF may be found in IEEE Std 469. This test is not practical for transformers larger than 50 kVA because of test facility limitations.
<b>Dielectric</b>										
Winding insulation resistance			*	*			*			
Core insulation resistance			*	*			*			The insulation resistance between the core(s) and ground shall be measured after complete assembly of the transformer at a level of at least 500 V dc, for a duration of 1 min.

Tests	Distribution transformers			Class I power transformers			Class II power transformers			Comments
	Routine	Design	Other	Routine	Design	Other	Routine	Design	Other	
Partial discharge test for core gassing		*		*						Test only applies to wound cores. See 6.7.2.1
Insulation power factor and capacitance			*	*			*			
Single-phase excitation tests on the rated voltage connection			*			*			*	This test shall be performed on all phases of any winding only when terminals are brought out and accessible for suitable connections. Only line-to-ground voltage suitable for the winding shall be applied during this measurement.
Low-frequency test on auxiliary devices and control and current transformer circuits			*	*			*			Control and voltage transformer secondary circuits shall be tested at 1500 V ac 50/60 Hz, and current transformer circuits shall be tested at 2.5 kV ac 50/60 Hz for 1 min duration.
Lightning impulse	*	*	*		*	*	*			A special routine impulse test for distribution transformers is required for overhead, pad-mounted, and underground type distribution transformers. This test is specified in 10.4 of IEEE Std C57.12.90-2021.
Front-of-wave impulse						*			*	
Switching impulse, phase-to-ground						*	*		*	Switching impulse tests are routine for transformers with high-voltage windings operating at 345 kV and above.
Low frequency	*			*			*			
Partial discharge test			*			*	*			
<b>Mechanical</b>										
Lifting and moving devices		*			*			*		The mechanical adequacy of the lifting and moving devices may be determined either by test or mathematical analysis.
Pressure		*			*			*		
Leak	*			*			*			

### **8.2.4 Dielectric test for low-voltage control wiring, associated auxiliary control equipment, and current transformer secondary circuits, on Class II power transformers**

For fully assembled Class II power transformers, dielectric withstand test (Hipot) shall be performed for 1 min on low-voltage control wiring (on each terminal or all terminals tied together), including LTC control and motor wiring when terminated in the control box. However:

- 1) All solid state and microprocessor-based devices shall be excluded from the test circuit.
- 2) All three-phase undervoltage relays and withdrawal type devices shall be removed from the test circuits.

At the location of each tap(s) termination in the control box, 2500 V ac shall be applied to the entire current transformer secondary circuits.

### **8.2.5 Audible sound level requirements**

The transformer shall be connected for and energized at rated voltage, frequency, and at no load. Noise-contributing elements of the transformer, such as pumps and fans, shall be operated as appropriate for the rating being tested. At least one test shall be performed at the cooling stage for the minimum rating and one test at the cooling stage for the maximum rating. When it is impractical or undesirable to include the appropriate cooling equipment, the self-cooled sound level may be corrected for cooling noise contribution, if suitable corrections are available and it is mutually agreeable to those concerned. Transformers shall meet standard audible no-load sound level as listed in Table C.1 for power and distribution transformers given in Annex C, or as specified by the purchaser. Upon purchaser's request, the transformer may be tested for its audible load sound level in order to determine the total sound level of the transformer under prespecified load(s) according to the calculations described in 13.6.2.2 of C57.12.90-2021. For reference load sound pressure levels, refer to Table C.2. In either case, the purchaser's specification shall make it clear whether the sound levels to be guaranteed refer to no-load noise or the total noise of the transformer, including load noise. When the purchaser's specification does not make it clear at which condition(s) the sound level shall be guaranteed, the default condition for sound level measurements shall be the no-load condition(s). Sound pressure levels given in Annex C for no-load and load noise correspond to sound levels of transformers where no special design, or external means of noise reduction, are used. These sound pressure levels apply to both single- and three-phase transformers. The objective of these levels is to be used as a measuring stick for how much lower a guaranteed sound level of a transformer is from these levels. Specifying the sound level of a transformer should be based on the required sound level at the substation boundary.

## **8.3 Additional routine tests on transformers with load tap changing or regulating transformers**

### **8.3.1 Ratio tests on load tap changing transformers**

Ratio tests on load tap changing transformers shall be made:

- a) At all connection positions of the tap-changer for de-energized operation with the LTC on the rated voltage position.
- b) At all LTC positions with the tap-changer for de-energized operation on the rated-voltage position.

### **8.3.2 Impedance voltage and load-loss tests on load tap changing transformers**

Impedance voltage and load-loss tests, as listed in Table 18, shall be made on one unit of a given rating when multiple units are produced by one manufacturer at the same time.

**Table 18—Additional tests**

Test number	Voltages for which tap-changers are set	
	Tap changer for de-energized operation	Load tap changer
1	Rated voltage tap position	Maximum voltage tap position
2 <sup>a</sup>	Rated voltage tap position	Minimum voltage tap position
3	Maximum voltage tap position	Maximum voltage tap position
4 <sup>a</sup>	Maximum voltage tap position	Minimum voltage tap position
5	Minimum voltage tap position	Maximum voltage tap position
6 <sup>a</sup>	Minimum voltage tap position	Minimum voltage tap position

<sup>a</sup> For tests 2, 4, and 6, the current held may be such that the current in the winding corresponds to the rated kVA and the rated winding voltage, when the transformer has been so designed with the LTC. All other tests shall be made at currents corresponding to the rated kVA and the voltage of the tap position being tested.

### 8.3.2.1 Impedance testing of regulating transformers

The impedance of regulating transformers shall be tested at the maximum and minimum rated voltage positions and at the neutral position of the LTC.

### 8.3.2.2 Test report

When a test report is specified, the impedance values of impedance voltage and load-loss tests on load tap changing transformers or impedance testing of regulating transformers shall be included in the report.

## 8.4 Determination of transformer regulation

When specified, transformer regulation shall be determined for the rated voltage, kVA, and frequency by means of calculations based on the tested impedance and load losses in accordance with IEEE Std C57.12.90. Regulation calculations shall be based on a reference temperature defined as 20 °C plus the rated average winding temperature rise.

## 8.5 Determination of thermal duplicate temperature-rise data

When specifications state that a thermal test may be omitted if there are thermal test data available for a thermal duplicate transformer, then calculated data based on the thermal test data may be submitted as thermal duplicate test data. A thermal duplicate is a transformer whose thermal design characteristics are identical to a design previously tested, or whose differences in thermal characteristics are within agreed-on variations, such that the thermal performance of the thermal duplicate transformer shall comply with performance guarantees established by standards or specifications.

## 8.6 Frequency conversion of transformer performance parameters (50/60 Hz)

It is preferred to do the tests at the rated frequency. When the tests cannot be done at the rated frequency, upon mutual agreement with the customer at the tender stage or prior to a contract, conversion factors given in IEEE Std C57.12.90 shall be used to convert the measured values from the frequency used for measurement

to the required rated frequency. The purpose of the frequency conversion factors is to have uniformity among the manufacturers when such cases arise.

## 8.7 Certified test data

The minimum information listed in this subclause shall be included in manufacturer's certified test data.

- a) Order data
  - 1) Purchaser
  - 2) Purchaser's order number
  - 3) Manufacturer's production order number and serial number
  
- b) Rating data
  - 1) Type (power, auto, grounding, etc.)
  - 2) Type of construction (core form or shell form)\*
  - 3) Cooling class
  - 4) Number of phases
  - 5) Connections (delta, wye, zigzag, etc.)
  - 6) Polarity for single-phase transformers
  - 7) Frequency\*
  - 8) Insulating liquid (mineral oil, less-flammable hydrocarbon fluid, silicone insulating fluid, natural ester fluid, etc.)\*
  - 9) Temperature rise\*
  - 10) Winding ratings: voltage, voltampere, BIL, all temperature rise ratings specified, including future ratings\*
  - 11) Harmonic loss factor if other than standard\*
  
- c) Test and calculated data (by individual serial number; if the results are from another transformer "design" tested, provide serial number, kV and kVA ratings, and date of the test)
  - 1) Date of test
  - 2) Winding resistances, including stabilizing winding when two external terminals are available.\*\*
  - 3) Losses: no-load, load, auxiliary, and total
  - 4) Impedance(s) in %
  - 5) Excitation current in %
  - 6) Thermal performance data\*\*
    - i. Ambient temperature
    - ii. Tap position, total loss, and line currents for total loss runs
    - iii. Insulating liquid flow in winding (directed or non-directed)
    - iv. Final bottom and top insulating liquid temperature rise over ambient for total loss run for each test
    - v. Average winding temperature rise over ambient for each winding for each test
    - vi. Calculated winding hottest spot temperature rise over ambient for maximum rating
  - 7) Zero-sequence impedance (when specified)\*
  - 8) Regulation (calculated when specified)
  - 9) Applied-voltage test values for each winding\*

- 10) Induced-voltage test value, including measured PD values when required\*
- 11) Impulse test data per IEEE Std C57.98™ [B14] (when required or specified)\*
- 12) Switching impulse test data (when specified)\*
- 13) Sound level test results (when specified)\*
- 14) Short-circuit test results (when specified)\*
- 15) Ratio test results\*
- 16) Phase relation or polarity test results\*
- 17) DOE compliant. If this transformer is to be used in the United States or one of its protectorates or territories and is required to comply with 10 CFR Part 431 [B3], the phrase “DOE Compliant” shall be included. Transformers that must meet this Code of Federal Regulation are defined in 10 CFR 431.192. At the discretion of the user, the actual calculated DOE efficiency value may be substituted for this phrase. This efficiency calculation shall be performed per 10 CFR Part 431 and 10 CFR 431.192.
- 18) Other special test results (when specified)\*

d) Certification statement and approval

NOTE 1—Items identified with an asterisk (\*) are not required for distribution transformers unless specified by the user.

NOTE 2—Number of significant figures of reported data should reflect the level of the data accuracy.

NOTE 3—All temperature sensitive data should be reported after correcting to the reference temperature as defined by IEEE Std C57.12.80 and 5.9 of this standard.

NOTE 4—Other significant information, such as tap position during induced potential test, test connection used, and any particular method used when alternatives are allowed in the test code, should be included.

NOTE 5—Other drawings, such as nameplate and outline, may be made a part of certified test data in place of duplicating the same information.

NOTE 6—Items identified with a double asterisk (\*\*) are not required for distribution transformers 2500 kVA and smaller, unless specified by the user.

## 9. Tolerances

### 9.1 Tolerances for ratio

The turns ratios between windings shall be such that, with the transformer at no load and with rated voltage on the winding with the least number of turns, the voltages of all other windings and all tap connections shall be within 0.5% of the nameplate voltages. However, when the volts per turn of the winding exceeds 0.5% of the nameplate voltage, the turns ratio of the winding on all tap connections shall be to the nearest turn.

For three-phase Y-connected windings, this tolerance applies to the phase-to-neutral voltage. When the phase-to-neutral voltage is not explicitly marked on the nameplate, the rated phase-to-neutral voltage shall be calculated by dividing the phase-to-phase voltage markings by  $\sqrt{3}$ .

For transformers with reactance type tap-changers, the turns ratio at the bridging tap position is the average of the two adjacent non-bridging tap positions, since the preventive autotransformer/reactor provides the center tap. Caution is advised when measuring the ratio by a ratio meter that applies a small voltage, since in the bridging tap position the excitation current drawn by the reactor affects the output voltage, and the ratio value displayed by the instrument could be in error. For this reason, the ratio at the bridging tap shall not be subject to the tolerance limit, provided the ratio at the adjacent non-bridging positions is within the tolerance limit, and it can be shown that the incorrect ratio is the result of meter limitations, and not due to incorrect design, construction, or connection of the reactor. If equalizer windings are used, the preventive autotransformer will be energized in all tap positions (bridging and non-bridging), and the highest voltage

can be experienced in either bridging or non-bridging positions. The ratio meter could also be affected in non-bridging position if a small voltage is applied.

## 9.2 Tolerances for impedance

The tolerances for impedance shall be as follows:

- a) The impedance of a two-winding transformer with an impedance voltage greater than 2.5% shall have a tolerance of  $\pm 7.5\%$  of the specified value, and those with an impedance voltage of 2.5% or less shall have a tolerance of  $\pm 10\%$  of the specified value.

Differences of impedance between duplicate two-winding transformers, when two or more units of a given rating are produced by one manufacturer at the same time, shall not exceed 7.5% of the specified value.

- b) The impedance of a transformer having three or more windings, or having zigzag windings, shall have a tolerance of  $\pm 10\%$  of the specified value.

Differences of impedance between duplicate three-winding or zigzag transformers, when two or more units of a given rating are produced by one manufacturer at the same time, shall not exceed 10% of the specified value.

- c) The impedance of an autotransformer shall have a tolerance of  $\pm 10\%$  of the specified value.

Differences of impedance between duplicate autotransformers, when two or more units of a given rating are produced by one manufacturer at the same time, shall not exceed 10% of the specified value.

- d) Transformers shall be considered suitable for operation in parallel when reactances come within the limitations of the preceding paragraphs, provided that turns ratios and other controlling characteristics are suitable for such operation.

## 9.3 Tolerances for losses

Unless otherwise specified, the losses represented by a test of a transformer shall be subject to the following tolerances: The no-load losses of a transformer shall not exceed the specified no-load losses by more than 10%, and the total losses of a transformer shall not exceed the specified total losses by more than 6%. Failure to meet the loss tolerances shall not warrant immediate rejection, but shall lead to consultation between purchaser and manufacturer regarding the further investigation of possible causes and the consequences of the higher losses.

It is important to note that this subclause is only an acceptance criterion and is not intended to replace a manufacturer's guarantee of losses for economic loss evaluation purposes.

## 9.4 Accuracies required for measuring losses

Measured values of electric power, voltages, currents, resistances, and temperatures are used in the calculations of reported data. To ensure sufficient accuracy in the measured and calculated data, the following requirements shall be met:

- a) Test procedures in accordance with IEEE Std C57.12.90-2021 Clause 5, Clause 8, and Clause 9 are required.
- b) The test equipment utilized for measuring losses of power and distribution transformers shall meet the requirements of IEEE Std C57.12.90-2021 Clause 5, Clause 8, and Clause 9.
- c) The test system accuracy for each quantity measured shall fall within the limits specified in Table 19.

- d) Frequency of the test source shall be within  $\pm 0.5\%$  of the rated frequency of the transformer under test.

**Table 19—Test system accuracy requirements**

Quantity measured	Test system accuracy
Losses	$\pm 3.0\%$
Voltage	$\pm 0.5\%$
Current	$\pm 0.5\%$
Resistance	$\pm 0.5\%$
Temperature	$\pm 1.5\text{ }^{\circ}\text{C}$

## 10. Connection of transformers for shipment

Single-phase and three-phase transformers shall be shipped with both high-voltage and low-voltage windings connected for their rated voltage. Unless otherwise specified, single-phase transformers designed for both series-multiple and three-wire operation shall be shipped connected in series with the midpoint out for three-wire operation. Single-phase and three-phase transformers designed for series-multiple operation shall be shipped connected in series.

Unless otherwise specified, three-phase transformers designed for both  $\Delta$  and Y operation shall be shipped connected for the Y voltage.

## Annex A

(informative)

### Cooling class designations

Examples of the cooling class designations used in IEEE Std C57.12.00-1993 and in previous revisions, with the corresponding present designations, are reproduced in Table A.1 for historical reference (previously Table 2 in IEEE Std C57.12.00-2010). Additional descriptive information for cooling class designations may be found in Annex A of IEEE Std C57.12.80.

**Table A.1—Cooling class designations**

Present designations	Previous designations
ONAN	OA
ONAF	FA
ONAN/ONAF/ONAF	OA/FA/FA
ONAN/ONAF/OFAF	OA/FA/FOA
ONAN/OFAF	OA/FOA
ONAN/ODAF/ODAF	OA/FOA <sup>a</sup> /FOA <sup>a</sup>
OFAF	FOA
OFWF	FOW
ODAF	FOA <sup>a</sup>
ODWF	FOW <sup>a</sup>
<p>NOTE—In a transformer designated as having forced directed coolant circulation (second code letter D), the rate of coolant flow through the main windings is determined by the pumps and not by the loading. A minor fraction of the coolant flow through the cooling equipment may be directed outside the main windings to provide cooling for core and other parts. Regulating windings and/or other windings having relatively low power may also have non-directed coolant circulation.</p>	

<sup>a</sup>Indicates directed oil flow per NOTE.

## Annex B

(informative)

### Front-of-wave test levels

With improved arrester technology, front-of-wave tests are no longer necessary or standard for distribution or power transformers, so these tests were removed as a requirement from IEEE Std C57.12.00. Gapped silicon carbide arresters have switching characteristics that closely mimic front-of-wave shapes. Metal oxide varistor (MOV) surge arresters have clamping characteristics that more nearly emulate full-wave and chopped-wave conditions. They have replaced silicon carbide arresters, negating the need for front-of-wave testing. However, a few users continue to specify front-of-wave tests, and as a historical reference, Table B.1 lists the front-of-wave test levels as published in Table 4 of IEEE Std C57.12.00-1980.

**Table B.1—Front-of-wave test, voltages in kV**  
 (The front-of wave test is no longer specified in IEEE C57™ standards, but is documented for historical purposes.)

Application	BIL (kV)	Minimum crest voltage (kV)	Specific time to sparkover <sup>a</sup> (μs)
Distribution	30	—	—
	45	—	—
	60	—	—
	75	—	—
	95	—	—
	125	—	—
	150	—	—
	200	—	—
	250	—	—
Power	350	—	—
	45	—	—
	60	—	—
	75	—	—
	95	165	0.5
	110	195	0.5
	150	260	0.5
	200	345	0.5
	250	435	0.5
	350	580	0.58
	450	710	0.71
	550	825	0.825
	650	960	0.96
750	1070	1.07	
825	1150	1.15	

**Table B.1—Front-of-wave test, voltages in kV (continued)**

Application	BIL (kV)	Minimum crest voltage (kV)	Specific time to sparkover <sup>a</sup> (μs)
Power	900	1240	1.24
	1050	1400	1.40
	1175	1530	1.53
	1300	—	—
	1425	—	—
	1550	—	—
	1675	—	—
	1800	—	—
	1925	—	—
	2050	—	—
	2175	—	—
	2300	—	—
	2425	—	—

<sup>a</sup>Tolerance on time-to-flashover is -0.1 and +0.3 μs.

-----

**Annex C**

(normative)

**Audible sound pressure levels for no-load and load noise of liquid-immersed power and distribution transformers**

**Table C.1—Audible sound pressure levels for no-load noise of liquid-immersed power and distribution transformers**

Sound pressure level, dB (A)	Equivalent two-winding kVA rating																		
	350 kV BIL and below			450 kV, 550 kV, 650 kV BIL			750 kV and 825 kV BIL			900 kV and 1050 kV BIL			1175 kV BIL			1300 kV BIL and above			
	1	2	3	1	2	3	1	2	3	1	2	3	1	2	3	1	2	3	
48	≤ 50																		
51	100																		
55	300																		
56	500																		
57	700																		
58	1000																		
59				700															
60	1500			1000															
61	2000																		
62	2500			1500															
63	3000			2000															
64	4000			2500															
65	5000			3000															
66	6000			4000			3000												
67	7500	6250*		5000	3750*		4000	3125*											
68	10 000	7500		6000	5000		5000	3750											
69	12 500	9375		7500	6250		6000	5000											
70	15 000	12 500		10 000	7500		7500	6250											
71	20 000	16 667		12 500	9375		10 000	7500											
72	25 000	20 000	20 800	15 000	12 500		12 500	9375											
73	30 000	26 667	25 000	20 000	16 667		15 000	12 500		12 500									
74	40 000	33 333	33 333	25 000	20 000	20 800	20 000	16 667		15 000			12 500						
75	50 000	40 000	41 687	30 000	26 667	25 000	25 000	20 000	20 800	20 000	16 667		15 000			12 500			
76	60 000	53 333	50 000	40 000	33 333	33 333	30 000	26 667	25 000	25 000	20 000	20 800	20 000	16 667		15 000			
77	80 000	66 687	66 667	50 000	40 000	41 667	40 000	33 333	33 333	30 000	26 667	25 000	25 000	20 000	20 800	20 000	20 000	16 667	20 800
78	100 000	80 000	83 333	60 000	53 333	50 000	50 000	40 000	41 667	50 000	33 333	33 333	30 000	26 667	25 000	25 000	20 000	20 000	20 800
79		106 667	100 000	80 000	66 667	66 667	60 000	53 333	50 000	60 000	40 000	41 667	40 000	33 333	33 333	30 000	26 667	25 000	
80		133 333	133 333	100 000	80 000	83 333	80 000	66 667	66 667	80 000	53 333	50 000	50 000	40 000	41 667	40 000	33 333	33 333	
81			166 667		10 6667	100 000	100 000	80 000	83 333	100 000	66 667	66 667	60 000	53 333	50 000	50 000	40 000	41 667	
82			200 000		133 333	133 333		106 867	100 000		80 000	83 333	80 000	66 667	66 667	60 000	53 333	50 000	
83			250 000			166 667		133 333	133 333		106 867	100 000	100 000	80 000	83 333	80 000	66 667	68 667	
84			300 000			200 000			166 667		133 333	133 333		106 667	100 000	100 000	80 000	83 333	
85			400 000			250 000			200 000			166 667		133 333	133 333		106 667	100 000	
86						300 000			250 000			200 000			166 667		133 333	133 333	
87						400 000			300 000			250 000			200 000		168 667	168 667	
88									400 000			300 000			250 000			200 000	

IEEE Std C57.12.00-2021  
IEEE Standard for General Requirements for Liquid-Immersed Distribution, Power, and Regulating Transformers

Sound pressure level, dB (A)	Equivalent two-winding kVA rating																				
	350 kV BIL and below			450 kV, 550 kV, 650 kV BIL			750 kV and 825 kV BIL			900 kV and 1050 kV BIL			1175 kV BIL			1300 kV BIL and above					
	1	2	3	1	2	3	1	2	3	1	2	3	1	2	3	1	2	3			
89												400 000						300 000			250 000
90																		400 000			300 000
91																					400 000

Note 1 Column 1 Class ONAN, ONWN, OFWF, ODWF, and ONWF ratings

Column 2 Class ONAF, OFAF, and ODAF first stage auxiliary cooling

Column 3 Straight OFAF ratings, ONAF, and ODAF second stage auxiliary cooling

Note 2 Classes of cooling, see 5.1

Note 3 First- and second-stage auxiliary cooling, see Table 1 of IEEE Std C57.12.10-2017

Note 4 For Column 2 and 3 ratings, the sound levels are with the auxiliary cooling equipment in operation

Note 5 For intermediate kVA ratings, use the average sound level of the next larger kVA rating

Note 6 The equivalent two-winding 65 °C rise rating is defined as one-half the sum of the kVA rating of all of the main windings of the transformer

Note 7 BIL level is for the high-voltage winding of the transformer

Note 8 The sound pressure levels listed here are the same as those listed in NEMA TR1-2013 [B50]

\* 67 dB for all kVA ratings equal to this or smaller

*Reprinted by permission of the National Electrical Manufacturers Association, NEMA TR1-2013.*

**Table C.2—Reference audible sound pressure levels of load noise**

MVA**	Sound pressure level, dB (A)
20	61
30	64
40	66
60	68
80	70
100	71
120	72
140	73
160	74
180 to 220	75
240 to 400	76
420 to 520	77
540 to 800	78

NOTE—For intermediate MVA ratings, interpolate using the sound levels in the range of the closest MVA ratings.

\*\* Top MVA rating

## Annex D

(informative)

### Bibliography

Bibliographical references are resources that provide additional or helpful material but do not need to be understood or used to implement this standard. Reference to these resources is made for informational use only.

- [B1] ASME B1.1, Unified Inch Screw Threads (UN and UNR Thread Form).<sup>15</sup>
- [B2] ASTM D117-2010, Standard Guide for Sampling, Test Methods, Specifications, and Guide for Electrical Insulating Oils of Petroleum Origin.<sup>16</sup>
- [B3] Code of Federal Regulations Title 10 Part 431 Subpart K (10CFR431.K), Energy Efficiency Program for Certain Commercial and Industrial Equipment.<sup>17</sup>
- [B4] IEC 60076-2:2011, Power transformers—Part 2: Temperature rise for liquid-immersed transformers.<sup>18</sup>
- [B5] IEC 60076-10:2001, Power transformers—Part 10: Determination of sound levels.
- [B6] IEEE Std 4™, IEEE Standard for High-Voltage Testing Techniques.<sup>19, 20</sup>
- [B7] IEEE Std 1313.2™, IEEE Guide for the Application of Insulation Coordination.
- [B8] IEEE Std 1538™, IEEE Guide for Determination of Maximum Winding Temperature Rise in Liquid-Filled Transformers.
- [B9] IEEE Std C57.21™, IEEE Standard Requirements, Terminology, and Test Code for Shunt Reactors Rated over 500 kVA.
- [B10] IEEE Std C57.32™, IEEE Standard for Requirements, Terminology, and Test Procedures for Neutral Grounding Devices.
- [B11] IEEE Std C57.91™, IEEE Guide for Loading Mineral-Oil-Immersed Transformers and Step Voltage Regulators.
- [B12] IEEE Std C57.93™, IEEE Guide for Installation and Maintenance of Liquid-Immersed Power Transformers.
- [B13] IEEE Std C57.95™, IEEE Guide for Loading Liquid-Immersed Step-Voltage and Induction-Voltage Regulators.
- [B14] IEEE Std C57.98™, IEEE Guide for Transformer Impulse Tests.
- [B15] IEEE Std C57.100™, IEEE Standard Test Procedure for Thermal Evaluation of Insulation Systems for Liquid-Immersed Distribution and Power Transformers.
- [B16] IEEE Std C57.104™, IEEE Guide for the Interpretation of Gases Generated in Mineral Oil-Immersed Transformers.

---

<sup>15</sup> ASME publications are available from the American Society of Mechanical Engineers (<https://www.asme.org/>).

<sup>16</sup> ASTM publications are available from the American Society for Testing and Materials (<https://www.astm.org/>).

<sup>17</sup> CFR publications are available from the U.S. Government Printing Office (<http://www.gpo.gov/>).

<sup>18</sup> IEC publications are available from the International Electrotechnical Commission (<https://www.iec.ch>) and the American National Standards Institute (<https://www.ansi.org/>).

<sup>19</sup> IEEE publications are available from The Institute of Electrical and Electronics Engineers (<http://standards.ieee.org/>).

<sup>20</sup> The IEEE standards or products referred to in Annex D are trademarks owned by The Institute of Electrical and Electronics Engineers, Incorporated.

- [B17] IEEE Std C57.105™, IEEE Guide for Application of Transformer Connections in Three-Phase Distribution Systems.
- [B18] IEEE Std C57.106™, IEEE Guide for Acceptance and Maintenance of Insulating Oil in Equipment.
- [B19] IEEE Std C57.109™, IEEE Guide for Liquid-Immersed Transformer Through-Fault-Current Duration.
- [B20] IEEE Std C57.110™, IEEE Recommended Practice for Establishing Liquid-Filled and Dry-Type Power and Distribution Transformer Capability When Supplying Nonsinusoidal Load Currents.
- [B21] IEEE Std C57.111™, IEEE Guide for Acceptance of Silicone Insulating Fluid and Its Maintenance in Transformers.
- [B22] IEEE Std C57.113™, IEEE Guide for Partial Discharge Measurement in Liquid-Filled Power Transformers and Shunt Reactors.
- [B23] IEEE Std C57.114™, IEEE Seismic Guide for Power Transformers and Reactors.
- [B24] IEEE Std C57.116™, IEEE Guide for Transformers Directly Connected to Generators.
- [B25] IEEE Std C57.120™, IEEE Loss Evaluation Guide for Power Transformers and Reactors.
- [B26] IEEE Std C57.121™, IEEE Guide for Acceptance and Maintenance of Less-Flammable Hydrocarbon Fluid in Transformers.
- [B27] IEEE Std C57.147™, IEEE Guide for Acceptance and Maintenance of Natural Ester Fluids in Transformers.
- [B28] IEEE Std C57.154™, IEEE Standard for the Design, Testing, and Application of Liquid-Immersed Distribution, Power, and Regulating Transformers Using High-Temperature Insulation Systems and Operating at Elevated Temperatures.
- [B29] IEEE Std C57.155™, IEEE Guide for Interpretation of Gases Generated in Natural Ester and Synthetic Ester-Immersed Transformers.
- [B30] IEEE Std C57.163™, IEEE Guide for Establishing Power Transformer Capability while under Geomagnetic Disturbances.
- [B31] IEEE Std C57.12.10™, IEEE Standard Requirements for Liquid-Immersed Power Transformers.
- [B32] IEEE Std C57.12.20™, IEEE Standard for Overhead-Type Distribution Transformers, 500 KVA and Smaller, High Voltage 34500 Volts and Below; Low Voltage 7970/13800Y Volts and Below.
- [B33] IEEE Std C57.12.23™, IEEE Standard for Submersible Single-Phase Transformers: 167 kVA and Smaller; High Voltage 25 000 V and Below; Low Voltage 600 V and Below.
- [B34] IEEE Std C57.12.24™, IEEE Standard for Submersible, Three-Phase Transformers, 3750 kVA and Smaller: High Voltage, 34 500 GrdY/19 920 V and Below; Low Voltage, 600 Volts and Below.
- [B35] IEEE Std C57.12.34™, IEEE Standard for Requirements for Pad-Mounted, Compartmental-Type, Self-Cooled, Three-Phase Distribution Transformers, 10 MVA and Smaller; High-Voltage, 34.5 kV Nominal System Voltage and Below; Low-Voltage, 15 kV Nominal System Voltage and Below.
- [B36] IEEE Std C57.12.36™, IEEE Standard Requirements for Liquid-Immersed Distribution Substation Transformers.
- [B37] IEEE Std C57.12.38™, IEEE Standard for Pad-Mounted-Type, Self-Cooled, Single-Phase Distribution Transformers 250 kVA and Smaller: High Voltage, 34 500 GrdY/19 920 V and Below; Low Voltage, 480/240 V and Below.
- [B38] IEEE Std C57.12.40™, IEEE Standard for Requirements for Secondary Network Transformers—Subway and Vault Types (Liquid-Immersed).
- [B39] IEEE Std C57.13™, IEEE Standard Requirements for Instrument Transformers.
- [B40] IEEE Std C57.13.1™, IEEE Guide for Field Testing of Relaying Current Transformers.

- [B41] IEEE Std C57.13.2<sup>TM</sup>, IEEE Standard Conformance Test Procedures for Instrument Transformers.
- [B42] IEEE Std C57.13.3<sup>TM</sup>, IEEE Guide for the Grounding of Instrument Transformer Secondary Circuits and Cases.
- [B43] IEEE Std C57.15<sup>TM</sup>/IEC 60076-21, IEEE/IEC International Standard—Power Transformers—Part 21: Standard requirements, terminology, and test code for step-voltage regulators.
- [B44] IEEE Std C57.19.00<sup>TM</sup>, IEEE Standard General Requirements and Test Procedures for Power Apparatus Bushings.
- [B45] IEEE Std C57.19.100<sup>TM</sup>, IEEE Guide for Application of Power Apparatus Bushings.
- [B46] IEEE Std C62.1<sup>TM</sup>-1989 (withdrawn), IEEE Standard for Gapped Silicon-Carbide Surge Arresters for AC Power Circuits.<sup>21</sup>
- [B47] IEEE Std C62.2<sup>TM</sup>-1987 (withdrawn), IEEE Guide for Application of Gapped Silicon-Carbide Surge Arresters for Alternating Current Systems.
- [B48] IEEE Std C62.11<sup>TM</sup>, IEEE Standard for Metal-Oxide Surge Arresters for AC Power Circuits (>1 kV).
- [B49] IEEE Std C62.22<sup>TM</sup>, IEEE Guide for the Application of Metal-Oxide Surge Arresters for Alternating-Current Systems.
- [B50] NEMA TR1-2013, Transformers, Step Voltage Regulators and Reactors.<sup>22</sup>

---

<sup>21</sup> IEEE Std C62.1-1989 and IEEE Std C62.2-1987 have been withdrawn; however, copies can be obtained from The Institute of Electrical and Electronics Engineers (<http://standards.ieee.org/>).

<sup>22</sup> NEMA publications are available from the National Electrical Manufacturers Association (<https://www.nema.org/>).

# RAISING THE WORLD'S STANDARDS

---

Connect with us on:



Twitter: [twitter.com/ieeesa](https://twitter.com/ieeesa)



Facebook: [facebook.com/ieeesa](https://facebook.com/ieeesa)



LinkedIn: [linkedin.com/groups/1791118](https://linkedin.com/groups/1791118)



Beyond Standards blog: [beyondstandards.ieee.org](https://beyondstandards.ieee.org)



YouTube: [youtube.com/ieeesa](https://youtube.com/ieeesa)

[standards.ieee.org](https://standards.ieee.org)

Phone: +1 732 981 0060

## **EXHIBIT 2**

# **PECO ENERGY COMPANY**

## **MATERIAL SPECIFICATION**

### **133 - P- 402**

#### **THREE-PHASE PADMOUNTED DISTRIBUTION TRANSFORMERS**

#### **1.0 Scope**

- 1.1 This specification covers the requirements for 60 Hertz, mineral oil-filled, self-cooled, three-phase, padmounted distribution transformers.
- 1.2 The transformers are classified as follows:
- 1.2.1 4kV - transformer shall operate on the 4kV distribution voltage system
  - 1.2.2 13kV - transformer shall operate on the 13kV distribution voltage system
  - 1.2.3 34kV - transformer shall operate on the 34kV distribution voltage system
  - 1.2.4 DTS - transformer is designed so that the primary is connected WYE with an isolated neutral and the secondary is 240V DELTA with 120V mid-tap
  - 1.2.5 STEP - transformer is a step or interposing unit designed to operate between two different distribution systems.
- 1.3 Transformers furnished under this specification shall be constructed in accordance with the Institute of Electrical and Electronics Engineers (IEEE) Standard for Requirements for Pad-Mounted, Compartmental-Type, Self-Cooled, Three-Phase Distribution Transformers, 5 MVA and Smaller; High-Voltage: 34.5 kV Nominal System Voltage and Below; Low Voltage, 15 kV Nominal System Voltage and Below, C57.12.34 - 2015 any other applicable IEEE standards.
- Transformers with an output voltage of 600 V or less shall also be constructed in accordance with the Department of Energy - Code of Federal Regulations (CRF) 10CFR Part 431 - Energy Conservation Program: Energy Conservation Standards for Distribution Transformers.
- 1.3.1 Exceptions to the IEEE standards are provided for within this specification.

#### **2.0 Ratings**

- 2.1 Kilovolt-Ampere Ratings
- 2.1.1 The KVA ratings for three-phase padmounted distribution transformers are specified in TABLE 1.
- 2.2 Voltage and Tap Ratings
- 2.2.1 The voltage rating shall be as defined in TABLE 1.
  - 2.2.2 No taps shall be provided.

#### **3.0 Basic Impulse Insulation Level (BIL)**

- 3.1 All components of the high-voltage system shall have a minimum BIL as stated below:
- 34kV - 150kV BIL**
  - 13kV - 95kV BIL**
  - 4kV - 60kV BIL**
- 3.2 For units that are designated as STEP, the low-voltage system shall have a BIL rating as specified in section 3.1.

## **4.0 Design**

### **4.1 Core and Coils**

**4.1.1** The transformers shall be designed to prevent tank heating due to fault conditions or unbalanced loads. This shall be accomplished by means of three single-phase core and coil units or five-legged core construction.

**4.1.2** The high-voltage and low-voltage coils for units designated as STEP shall be copper.

### **4.2 Low-Voltage Mid-Tap Neutral (DTS units only)**

**4.2.1** A mid-tap (X4 designation) shall be provided on the 240 Volt winding section midway (electrically) between the X1 and X2 terminals.

**4.2.2** The mid-tap lead shall have the same current carrying capacity as the low-voltage phase leads.

**4.2.3** The mid-tap bushing shall be fully insulated.

**4.2.4** A removable, external ground strap shall be connected between the X4 terminal and a ground pad located directly beneath the terminal in the low-voltage compartment.

### **4.3 Electrical Operation**

The transformers shall be designed for primary loop feed system operation.

### **4.4 Impedance**

**4.4.1** The impedance of the transformers shall be as specified in TABLE 2 of this specification.

## **5.0 Compartment/Enclosure Construction**

### **5.1 High-Voltage Bushings**

**5.1.1** Two 200 Amp, three-phase rated, high-voltage, loadbreak, insulated, separable connector bushings shall be provided per phase on the transformer for loop feed system operation.

**5.1.2** The following applies to units designated as 34kV Class:

**5.1.2.1** The bushings shall be 21.1kV phase-to-ground/36.6kV phase-to-phase rated, integral, loadbreak bushings. The bushings shall be either ERMCO **Part # 9U02DBC001** or Cooper Power Systems **Part # 2637024C01M**.

**5.1.2.2** The bushings shall be externally replaceable. The bushings shall be externally clamped and the leads shall have sufficient slack to allow the bushing to be disconnected.

**5.1.2.3** A label or stencil (minimum 1/2" height letters) with the words "**THREE PHASE RATED BUSHINGS**" shall be placed next to the high-voltage bushings. The label or stencil is to have a purple background (or letters) to indicate the color of the bushing nose cone.

**5.1.2.4** The bushing clamps shall have a four (4) studs configuration.

**5.1.3** The following applies to units designated as 4kV and 13kV Class:

**5.1.3.1** The bushings shall be 8.3kV phase-to-ground/14.4kV phase-to-phase rated, loadbreak bushings. The bushings shall be either integral bushings or bushing wells with inserts.

**5.1.3.2** The integral bushings or bushing wells shall be externally replaceable. The integral bushings or bushing wells shall be externally clamped and the leads shall have sufficient slack to allow the bushing to be disconnected.

5.1.4 Weather-tight protective caps shall be installed on the loadbreak bushings to provide protection during transportation and storage.

5.1.5 The make and model of the high-voltage bushings shall be shown on drawings to be reviewed and approved by PECO Energy Company.

5.2 Low-Voltage and Neutral Terminals and Bushings

5.2.1 The following applies to all units **except for units designated as STEP:**

5.2.1.1 The low-voltage and neutral terminals shall have a minimum number of useable NEMA spaced holes per phase as specified in the following table:

No. of Holes	Secondary Voltage			
	<u>208Y/120</u>	<u>240/120</u>	<u>240Y/139</u>	<u>480Y/277</u>
	KVA			
4	<b>75 - 150</b>	<b>75 - 150</b>	<b>150</b>	<b>150</b>
6	<b>300</b>	<b>300</b>	<b>300</b>	<b>300 - 750</b>
8	<b>500</b>	<b>500</b>	<b>500</b>	<b>1000</b>
10	-	-	<b>750</b>	-
12	<b>750</b>	-	-	<b>1500</b>
14	<b>1000</b>	-	-	-

5.2.1.2 For units designated as DTS or “floating” Y, the high-voltage neutral (H0) shall not be internally connected to ground or to the tank. The low-voltage mid-tap neutral shall be brought out externally through the X4 terminal and connected to the tank with an external jumper. The jumper shall be made of corrosion resistant material and be electrically equivalent to a minimum #4 AWG copper wire.

5.2.1.3 For units designated as “grounded” Y (GRDY) units, the high-voltage neutral (H0) and low-voltage neutral (X0) shall be connected internally through a removable link and brought out externally through the H0/X0 neutral terminal and connected to the tank with an external jumper. The jumper shall be made of corrosion resistant material and be electrically equivalent to a minimum #4 AWG copper wire. The H0/X0 removable link shall be accessible through the handhole (see 5.4.5.1).

5.2.1.4 The low-voltage and neutral terminals shall be externally replaceable.

5.2.1.5 The low-voltage and neutral terminals shall be designed to withstand the weight and/or vertical movement due to expansion and contraction of the low-voltage cables.

5.2.1.6 The low-voltage and neutral terminals provided shall conform to Figure 19 of IEEE Standard C57.12.34 -2015 and shall be plated or tinned to be compatible with copper or aluminum connectors and minimum useable NEMA spaced holes as specified in 5.2.1.1.

5.2.1.7 All transformers rated 300KVA and greater shall be furnished with additional insulated supports, designed by the manufacturer, at the end of the low-voltage terminals furthest from the tank wall. The supports shall be designed such that they will not interfere with the installation of secondary cables onto the low voltage terminals.

5.2.2 The following applies to units designated as STEP:

5.2.2.1 The low-voltage bushings shall be 8.3kV phase-to-ground/14.4kV phase to-phase rated, loadbreak bushings. The bushings shall be either integral bushings or bushing wells with inserts.

5.2.2.2 The low-voltage bushings arrangement shall be in-line type with parking stands in accordance with Figure 3 of IEEE C57.12.34 – 2015. The height of the bushings from the transformer base shall be 39” for units greater than 500KVA and 31” for units less than or equal to 500KVA. The neutral bushing (X0) shall be located 8” min. below the X1 bushing.

5.2.2.3 The integral bushings or bushing wells shall be externally replaceable. The integral bushings or bushing wells shall be externally clamped and the leads shall have sufficient slack to allow the bushing to be disconnected.

5.2.2.4 Weather-tight protective caps shall be installed on the low-voltage bushings to provide protection during transportation and storage.

5.2.2.5 The neutral terminal shall have a fully insulated bushing that is externally replaceable. The neutral terminal shall be an externally replaceable "H" spade and connected to the tank with an external jumper. The jumper shall be made of corrosion resistant material and be electrically equivalent to a minimum #4 AWG copper wire.

5.2.4 The make and model of the low-voltage and neutral terminals and bushings shall be shown on drawings to be reviewed and approved by PECO Energy Company.

### 5.3 Dimensions

5.3.1 Clearance above the parking stands shall be sufficient to allow for the use of "feed-throughs".

5.3.2 The maximum height of the sill shall be 18 inches.

5.3.3 The maximum depth, excluding cooling, of all transformer bases shall be 70 inches. The maximum width of all transformer bases shall be as follows:

<b>VOLTAGE CLASS</b>	<b>SIZE (KVA)</b>	<b>WIDTH (inches)</b>
4kV & 13 kV	750 & smaller	72
4kV & 13 kV	1000	78
34 kV	150 to 2500	84

### 5.4 Compartment Arrangement and Doors

5.4.1 The low-voltage compartment shall have, as a minimum, the dimensions and arrangement shown in Figure 8(a) of IEEE C57.12.34 - 2009.

5.4.2 The high-voltage compartment for the 4kV, 13kV and 34kV units shall conform to the dimensions and arrangements shown in FIGURES 2 and 3 of this specification.

5.4.3 The high-voltage compartment door shall be secured in the closed position with a captive, pentahead bolt. The pentahead bolt shall be accessible only after the low-voltage compartment door has been opened. The low-voltage compartment door shall also be secured in the closed position by means of a captive and recessed pentahead bolt.

5.4.4 The compartment doors shall be equipped with stops for latching in the open position.

#### 5.4.5 False Cover

5.4.5.1 A bolted handhole or main cover located on top of the transformer tank shall be made tamperproof by means of a false cover. The false cover shall be removable only after the low-voltage compartment door has been opened. The false cover shall not extend above the top of the high-voltage/low-voltage compartment.

5.4.5.2 The size of the handhole or main cover shall be reviewed and approved by PECO Energy Company prior to the manufacture of the transformers.

- 5.4.6 The compartment door padlock provisions shall be approved by PECO Energy Company prior to the manufacture of the transformers.
- 5.4.7 The high-voltage compartment door shall have the PECO Energy Company stock code number for the required bayonet fuse stenciled on the inside of the compartment door as described in Section 6.8.3 and oriented so as to be readable when opening the door.
- 5.5 Tank Grounding Connection
- 5.5.1 Two vise type, ground connectors shall be provided, near the bottom of the faceplate, to permit connection of a ground conductor to the transformer tank. The connector shall be corrosion resistant and shall accommodate two #2 AWG copper or aluminum conductors.
- 5.6 Hold - Down Provisions
- 5.6.1 Two hold-down cleats shall be provided to secure the transformer to its foundation or pad.
- 5.7 Transformer Oil
- 5.7.1 The transformer shall be mineral oil-filled.
- 5.7.2 The oil shall be PCB free, defined as less than 2 PPM.
- 5.7.3 A PCB free label shall be affixed on the on the compartment door as shown in FIGURE 2 of this specification.
- 5.8 Coating System
- 5.8.1 The transformer enclosure shall be finished with a topcoat color Munsell Number 7GY 3.29/1.5 pad-mount green in accordance with IEEE Standard C57.12.28 - 2014.

## **6.0 Accessories**

- 6.1 Overcurrent Protection
- 6.1.1 The transformer shall be equipped with a coordinated set of high-voltage loadbreak bayonet and partial range current limiting fuses to protect the system from overcurrent conditions inside the transformer. The bayonet and partial range current limiting fuse values for each KVA and voltage are specified in TABLE 2. The electrical connection (for each phase) of the fuses and gang-operated loadbreak switch, and if applicable, the surge arrester shall be as shown in FIGURE 1 attached to this specification. Any exceptions or deviations from these requirements shall be approved by the PECO Energy Company.
- 6.1.2 The bayonet expulsion fuse assembly shall be a Cooper Power System model 4000361C99FV except for the 4038361C05CB type bayonet fuse. For this bayonet type fuse, a Cooper fuse assembly model 4038804B03M shall be used.
- 6.1.3 The loadbreak rated bayonet fuse holder shall be physically located in the high-voltage compartment.
- 6.1.4 A drip tray shall be provided for the bayonet fuse. The tray shall be installed in such a manner to allow the tray to be removed without affecting the bayonet holder.
- 6.1.5 The fuse holders shall be designed to accommodate hot-line tools.
- 6.1.6 All parts and locations of the overcurrent protection for the transformer shall be shown on approval drawings sent to the PECO Energy Company.
- 6.1.7 The manufacturer shall supply a Time-Current Curve (TCC) for each transformer stock number. Each TCC shall have all the components of the overcurrent protection system and must include the transformer damage curve and the bayonet and partial current limiting fuses' min. and max melting curves. The TCCs shall be submitted to PECO Energy Company for approval prior to the manufacture of the transformers.

## 6.2 Primary Surge Arrester

6.2.1 For transformers that are designated as 34kV Class, a 27kV rated under-oil MOV surge arrester shall be mounted internally in the transformer for each phase.

6.2.1.1 The surge arrester supplied shall be either a Cooper Power Systems or General Electric type.

**Cooper**  
**AZU100L027**

**General Electric**  
**9L25BUK132B**

6.2.2 The ground lead of the surge arrester shall be solidly grounded inside the tank. An arrester ground disconnect switch shall be supplied to disconnect (isolate) the ground lead from the tank for testing purposes. A label shall be located next to the arrester switch in plain view to identify the switch and its on/off positions.

6.2.3 The MOV arresters shall be protected by the current limiting and bayonet fuses.

6.2.4 The words "**INTERNAL MOV ARRESTERS**" shall be stenciled on the transformer tank. The stenciling shall be located such that it is not obstructed from view.

## 6.3 Gang-Operated Loadbreak Switch

6.3.1 A high-voltage, gang-operated, two-position loadbreak switch shall be provided to energize and de-energize the transformer.

6.3.2 The switch shall be electrically connected as shown in FIGURE 1 of this specification.

6.3.3 The operating handle of the loadbreak switch shall be located in the high-voltage compartment in plain view in a manner as not to impede its operation with a hot-line tool. A label or stencil that reads: "**LOADBREAK SWITCH**" shall be located next to the switch in plain view.

6.3.4 The positions of the switch shall be clearly indicated.

6.3.5 The operating handle of the loadbreak switch shall be designed for hot line tools operation.

6.3.6 All parts of the high-voltage gang-operated switch external to the tank shall be of corrosion resistant material such stainless steel or solid brass. Aluminum, cast aluminum and/or plastic material **are not acceptable**.

6.3.7 The model/part number of the high-voltage gang operated switch and the location of the operating handle shall be shown on drawings to be submitted to PECO Energy Company for review and approval prior to the manufacture of the transformer.

## 6.4 Drain Valve

A drain valve with oil sampling capabilities shall be provided for all KVA size transformers and shall be located inside the high voltage compartment 6" (min.) from the centerline of the valve to the High/Low voltage barrier and at a height as to allow the oil to be completely drained from inside the tank.

## 6.5 Sight Glass

6.5.1 A sight glass, Heartland Solution Catalog No. HLG-1011 or equivalent, with corrosion resistant body and 120°C temperature rating shall be provided.

6.5.2 The sight glass shall be located inside the high voltage compartment at the minimum height where the oil is visible and it is acceptable to operate the primary loadbreak switch.

6.5.3 The sight glass shall be located at a height such that the oil level will be visible in the middle of the sight glass, at a minimum, when the ambient temperature of - 20°C and the transformer is not in service (e.g. de-energized).

## 6.6 Pressure Relief Device

6.6.1 A pressure relief valve shall be provided with the following venting and sealing characteristics.

6.6.1.1 Cracking pressure 10 psig +/- 2 psig

6.6.1.2 Resealing pressure 6 psig minimum

6.6.1.3 Flow at 15 psig, 35 SCFM minimum

6.6.1.4 Zero leakage from reseal pressure to -8 psig

## 6.7 Nameplate

6.7.1 A stainless steel Nameplate B, in accordance with IEEE Standard C57.12.00 - 2010, shall be installed inside the compartment and must include the following additional information:

- **Gallons of Oil**
- **PECO Energy Specification Number (133-P-401)**
- **PECO Energy Catalog id. (133-XXXXX)**
- **The words: "DOE 2016 COMPLIANT"** (for transformers with an output voltage of 600 V or less).

6.7.2 The nameplate schematic diagram shall show the electrical location of all the accessories supplied with the transformer such as the loadbreak switch and fuses.

## 6.8 Stenciling and Terminal Marking Requirements

6.8.1 The transformer's HV, LV and neutral terminal designations (i.e., H0, H1-3A, H1-3B, X0, X1, X2, X3 and X4) shall be marked on the tank wall adjacent to the terminals with a minimum of 1-1/2 inch minimum high yellow letters, either decal or stencil.

6.8.2 A 9" X 9" adhesive label containing the following information shall be affixed on the tank wall as show in FIGURE 4:

- System voltage: **4kV, 13kV or 34kV**
- KVA value and
- PECO Catalog ID. **133-XXXXX**

These labels shall be purchased from the UTICOM Company. Labels from an alternate manufacturer will not be acceptable unless approved by PECO:

6.8.3 The bayonet or full range current limiting fusing information (See Table 2 for Operating Voltage, Amp value, and PECO Energy Company stock code number for single and dual voltage units) shall be marked inside the compartment door and oriented so as to be readable when the door is opened with a 1 inch minimum high yellow letters, either decal or stencil. The following example shall be used to stencil the bayonet fusing information:

**"USE \_\_\_\_ AMP BAYONET FUSE PECO CODE NUMBER 138-\_\_\_\_"**

6.8.4 The transformers shall be shipped with PECO Energy Company high-voltage equipment Warning/Caution/Notice and PCB labels affixed externally on the compartment door. The labels shall be located in the center of the door above the top of the sill plate as shown in FIGURE 4 of this specification.

6.8.5 The Warning/Caution/Notice label shall be in accordance with FIGURE 5 of this specification. This label will be supplied to the manufacturer upon verbal request. Contact the PECO Energy Company's Procurement Specialist to obtain a supply of labels. Two weeks advance notice is required.

6.8.6 A yellow "CAUTION" decal, with minimum 1/4" black lettering shall be affixed below or next to the sight glass and read: "**DO NOT OPERATE PRIMARY SWITCH IF FLOAT INDICATOR IS AT THE BOTTOM OF SIGHT GLASS**" (see Section 6.5).

6.8.7 A yellow "CAUTION" decal, with minimum 1/4" black lettering shall be affixed below or next to the bayonet fuses and read: "**DO NOT OPERATE BAYONET FUSES IF FLOAT INDICATOR IS AT THE BOTTOM OF SIGHT GLASS**".

6.8.8 Lower size letters on smaller KVA units may be acceptable upon PECO's approval of drawings that show the stenciling and/or labels.

6.8.9 All markings (decal or stencil) and labels shall be weather resistant.

## **7.0 Design Approval and Test Data**

### **7.1 Design Approval**

7.1.1 The following drawings shall be submitted to PECO Energy Company for review and approval.

7.1.1.1 An outline drawing with a detailed bill of material (BOM). The BOM shall list all part numbers including manufacturer. The drawing shall show critical tank characteristics including but not limited to the following: tank material, size, dimensions, hanger bracket type, weight, accessories (e.g. loadbreak switch), labels, coating system, and terminal markings.

7.1.1.2 Drawings for each of the following transformer accessories:

7.1.1.2.1 High-voltage bushings

7.1.1.2.2 Low-voltage bushings and terminals

7.1.1.2.3 Neutral terminals

7.1.1.2.4 High-voltage gang operated load break switch

7.1.1.2.5 Bayonet fuse assembly

7.1.1.2.6 Pressure Relief Valve

7.1.1.2.7 Surge Arrester

7.1.1.2.8 Sight Glass

7.1.1.2.9 Drain Valve

7.1.1.3 A nameplate drawing that contains the information listed in Section 6.7.

7.1.2 All drawings, except for the part drawings, shall reference PECO Energy Company's specification number and Catalog Id. number.

7.1.3 Revisions to any drawing previously submitted and approved shall be re-submitted to PECO Energy Company for review and approval.

### **7.2 Test Data**

7.2.1 The manufacturer shall furnish, without cost to the PECO Energy Company, one certified copy of factory test data set for each transformer shipped. The data requirements shall include the standard, extended and calculated data sets listed in sections 4.2, 4.3 and 4.4 of IEEE Standard C57.12.37 - 2015 and transmitted to PECO Energy Company electronically (Microsoft EXCEL or compatible format) in accordance with the same standard. The price of the unit shall also be included in the standard data set.

7.2.2 Upon request, the manufacturer shall furnish, without cost to the PECO Energy Company, one certified copy of all factory design data. Design data may include, but not limited to: electrical tests including ANSI/IEEE dielectric tests, mechanical tests (pressure relief tests, etc.), and coating/corrosion minimizing tests.

## **8.0 Compliance Requirements**

- 8.1** The manufacturer shall comply with all the requirements of this specification and the Request for Proposal (RFP) covered by the Exelon Energy Delivery Purchase Order.
- 8.2** Any exceptions or deviations from either this specification or the RFP requirements shall be submitted in writing by the manufacturer to PECO Energy Company for review and approval.
- 8.3** Revision to drawings previously approved by PECO Energy Company must be re-submitted to PECO Energy Company for review and approval.

## **9.0 Packing and Shipping Requirements**

- 9.1** Transformers shall be firmly secured to wooden pallets for shipping. Pallets shall be made of wood with sufficient thickness as not to break under the weight of the transformer during shipment and storage, sized such that no part of the transformer extends beyond the vertical extension of the pallet's edges, and designed so that they can be picked up by a forklift truck. Transformers shall be side-loaded on open-top trucks for shipping.

**TABLE 1**

SYSTEM VOLTAGE CLASS	DESCRIPTION	75KVA	150KVA	300KVA	500KVA	750KVA	1000KVA	1500KVA	2500KVA
4kV	HV: 4160GRDY/2400 LV: 208Y/120	133-73000	133-73001	133-73002	133-73003	133-73004	-	-	-
4kV	HV: 4160GRDY/2400 LV: 480Y/277	-	133-73006	133-73007	133-73008	133-73009	133-73010	-	-
4kV DST	HV: 4160Y LV: 240 Delta w/120 MT	133-73011	133-73012	133-73013	133-73014	-	-	-	-
13kV	HV: 13200GRDY/7620 LV: 208Y/120	133-71491	133-71492	133-71494	133-71495	133-71496	133-72206	-	-
13kV	HV: 13200GRDY/7620 LV: 480Y/277	-	133-72195	133-72196	133-72197	133-72198	133-73024	133-73025	-
13kV DST	HV: 13200Y LV: 240 Delta w/120 MT	133-71497	133-71498	133-71499	133-73016	-	-	-	-
34kV	HV: 33260GRDY/19200 LV: 208Y/120	133-71478	133-71479	133-71480	133-71481	133-71482	-	-	-
34kV	HV: 33260GRDY/19200 LV: 480Y/277	-	133-72200	133-71486	133-71487	133-71488	133-71489	133-71490	-
34kV	HV: 33260GRDY/19200 LV: 240Y/139	-	133-72295	133-72296	133-72297	133-72298	-	-	-
13kV STEP	HV: 13200GRDY/7620 LV: 4160Y/2400	-	-	133-72225	133-72226	133-72227	133-72228	-	-
34kV STEP	HV: 33260GRDY/19200 LV: 4160Y/2400	-	-	-	133-72202	133-72244	133-72203	-	-
34kV STEP	HV: 33260GRDY/19200 LV: 13200Y/7620	-	-	-	-	-	-	133-72294	133-72293

DST- Unit connected with a Primary WYE and a Secondary DELTA  
STEP - STEP Down or Interposing Transformer

**TABLE 2**  
**IMPEDANCE AND FUSING REQUIREMENTS**

SYSTEM VOLTAGE CLASS	PECO Transformer Code Number	KVA Size	Min. IZ (%)	Operating Voltage	Fuse Size (Amp)	PECO Fuse Code No.	Bayonet Fuse Cooper Type	Partial or Full Range Current Limiting Fuse. Cooper Type Unless Specified
4kV	133-73000	75	2.0	4kV	25	138-29890	4000358C10	CBUC08100C100
	133-73001	150	2.0	4kV	50	138-29891	4000358C12	CBUC08165D100
	133-73002	300	3.0	4kV	100	138-29921	4000353C16	CBUC08165D100
	133-73003	500	4.0	4kV	140	138-29905	4000353C17	CBUC08150D100
	133-73004	750	5.5	4kV	125	138-76096	4038361C05CB	CBUC08250D100
	133-73006	150	2.0	4kV	50	138-29891	4000358C12	CBUC08165D100
	133-73007	300	3.0	4kV	100	138-29921	4000353C16	CBUC08165D100
	133-73008	500	4.0	4kV	140	138-29905	4000353C17	CBUC08150D100
	133-73009	750	5.5	4kV	125	138-76096	4038361C05CB	CBUC08250D100
4kV DTS	133-73010	1000	5.5	4kV	-	-	(*)	Parallel Hi-Tech HTSS232165
	133-73011	75	2.0	4kV	25	138-29890	4000358C10	CBUC08125C100
	133-73012	150	2.0	4kV	50	138-29891	4000358C12	CBUC08150D100
	133-73013	300	3.0	4kV	100	138-29921	4000353C16	CBUC08165D100
13kV	133-71491	75	1.6	13kV	8	138-29888	4000358C05	CBUC08030C100
	133-71492	150	2.0	13kV	15	138-29889	4000358C08	CBUC08080C100
	133-71494	300	3.0	13kV	40	138-29920	4000353C12	CBUC08100C100
	133-71495	500	3.5	13kV	50	138-29891	4000358C12	CBUC08150D100
	133-71496	750	4.0	13kV	100	138-29921	4000353C16	CBUC08165D100
	133-72206	1000	5.5	13kV	140	138-29905	4000353C17	CBUC08150D100 (2)**
	133-72195	150	2.0	13kV	15	138-29889	4000358C08	CBUC08080C100
	133-72196	300	3.0	13kV	40	138-29920	4000353C12	CBUC08100C100
	133-72197	500	3.5	13kV	50	138-29891	4000358C12	CBUC08150D100
	133-72198	750	5.5	13kV	100	138-29921	4000353C16	CBUC08165D100
	133-73024	1000	5.5	13kV	140	138-29905	4000353C17	CBUC08150D100 (2)**
	133-73025	1500	5.5	13kV	140	138-29905	4000353C17	CBUC08150D100 (2)**
13kV DTS	133-71497	75	1.5	13kV	8	138-29888	4000358C05	CBUC15030C100
	133-71498	150	3.0	13kV	15	138-29889	4000358C08	CBUC15080C100
	133-71499	300	2.0	13kV	40	138-29920	4000353C12	CBUC15100C100
	133-73016	500	3.5	13kV	50	138-29891	4000358C12	CBUC15125C100
34kV	133-71478	75	1.6	34kV	3	138-29887	4000358C03	CBUC23030C100
	133-71479	150	2.0	34kV	8	138-29888	4000358C05	CBUC23030C100
	133-71480	300	3.0	34kV	15	138-29889	4000358C08	CBUC23080C100
	133-71481	500	3.5	34kV	25	138-29890	4000358C10	CBUC23080C100
	133-71482	750	5.5	34kV	40	138-29920	4000353C12	CBUC23080C100
	133-72200	150	2.0	34kV	8	138-29888	4000358C05	CBUC23030C100
	133-71486	300	3.0	34kV	15	138-29889	4000358C08	CBUC23080C100
	133-71487	500	3.5	34kV	25	138-29890	4000358C10	CBUC23080C100
	133-71488	750	5.5	34kV	40	138-29920	4000353C12	CBUC23080C100
	133-71489	1000	5.5	34kV	50	138-29891	4000358C12	CBUC23125D100
	133-71490	1500	5.5	34kV	65	138-29902	4000353C14	CBUC23150D100
	133-72295	150	2.0	34kV	8	138-29888	4000358C05	CBUC23030C100
	133-72296	300	3.0	34kV	15	138-29889	4000358C08	CBUC23080C100
	133-72297	500	2.0	34kV	25	138-29890	4000358C10	CBUC23080C100
133-72298	750	5.5	34kV	40	138-29920	4000353C12	CBUC23080C100	
13kV STEP	133-72225	300	1.5	13kV	40	138-29920	4000353C12	CBUC08125C100
	133-72226	500	2.0	13kV	50	138-29891	4000358C12	CBUC08165D100
	133-72227	750	4.0	13kV	100	138-29921	4000353C16	CBUC08165D100
	133-72228	1000	5.5	13kV	140	138-29905	4000353C17	CBUC08150D100 (2)**
34kV STEP	133-72202	500	3.5	34kV	25	138-29890	4000358C10	CBUC23080C100
	133-72244	750	5.5	34kV	40	138-29920	4000353C12	CBUC23080C100
	133-72203	1000	5.5	34kV	50	138-29891	4000358C12	CBUC23125D100
	133-72294	1500	5.5	34kV	65	138-29902	4000353C14	CBUC23150D100
	133-72293	2500	5.5	34kV	-	-	-	-

(\*) In-Oil Expulsion Fuse ABB 592B581G32

(\*\*) 2 in Parallel

# FIGURE 1

## THREE PHASE PADMOUNTED TRANSFORMER

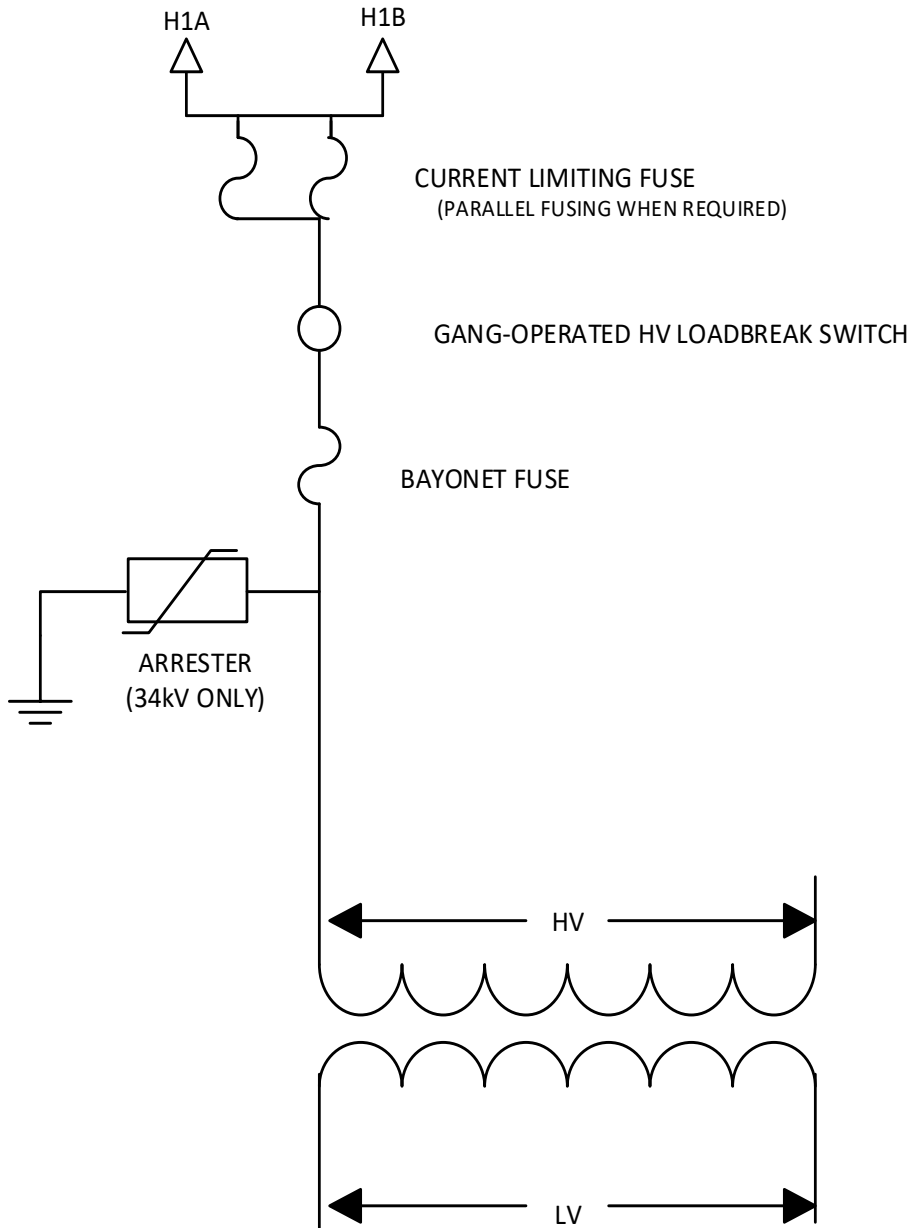

(Only one Phase is shown for Illustration Purposes Only)

## FIGURE 2

### THREE PHASE PADMOUNTED TRANSFORMER 4kV and 13kV HIGH VOLTAGE COMPARTMENT

NOTE: NOT DRAWN TO SCALE

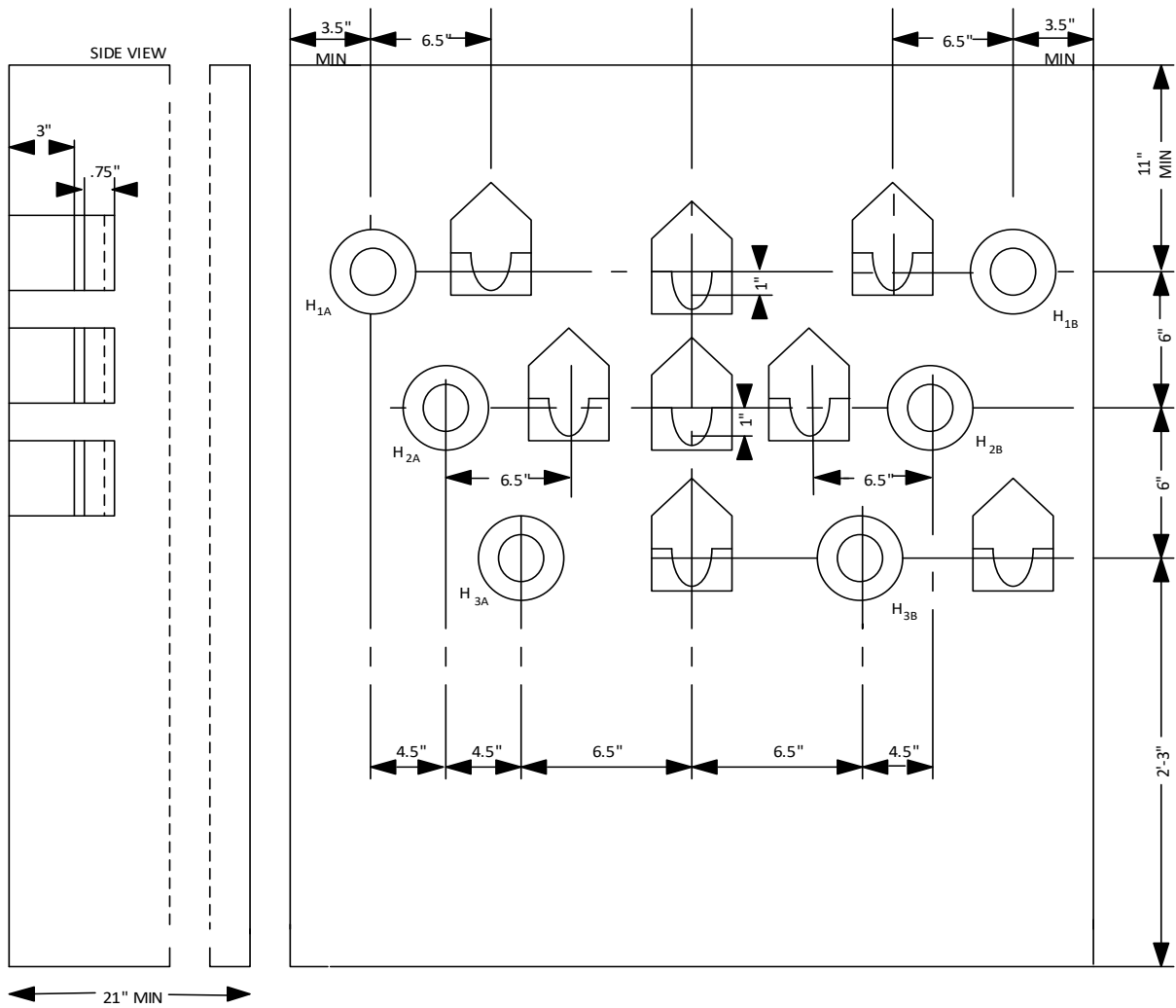

# FIGURE 3

## THREE PHASE PADMOUNTED TRANSFORMER 34KV HIGH VOLTAGE COMPARTMENT

NOTE: NOT DRAWN TO SCALE

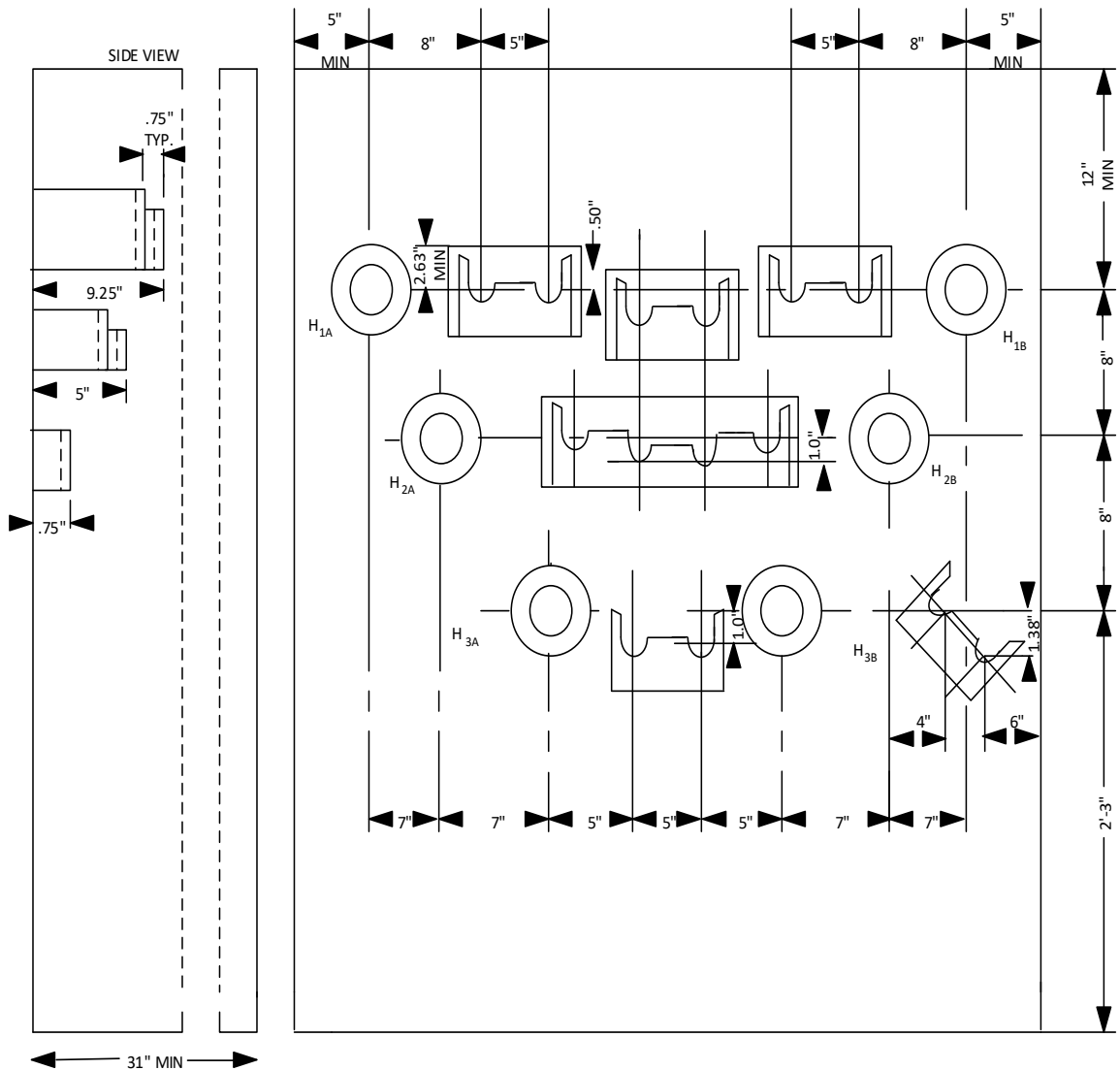

# FIGURE 4

## THREE PHASE PADMOUNTED TRANSFORMER EXTERNAL STENCILING/DECAL AND LABELING REQUIREMENTS

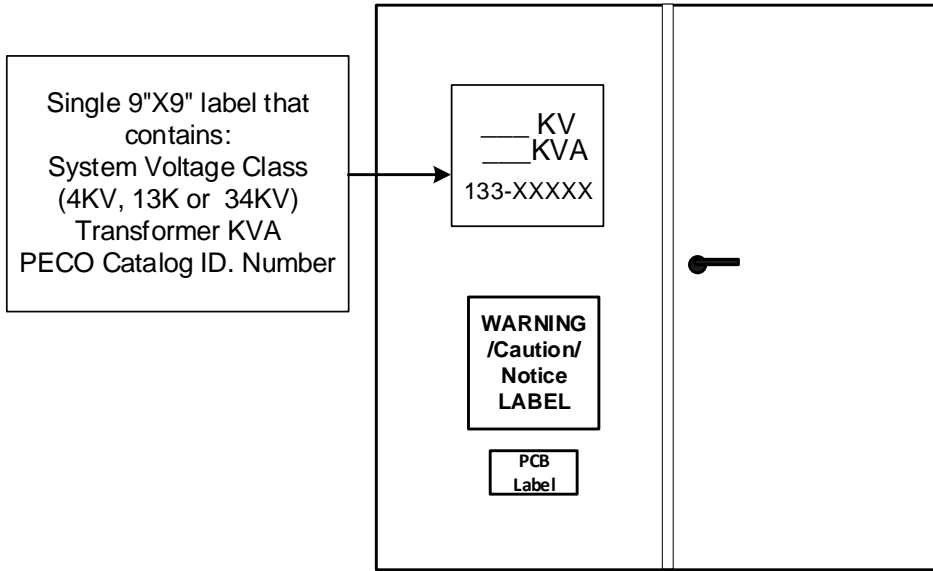

TRANSFORMER FRONT VIEW

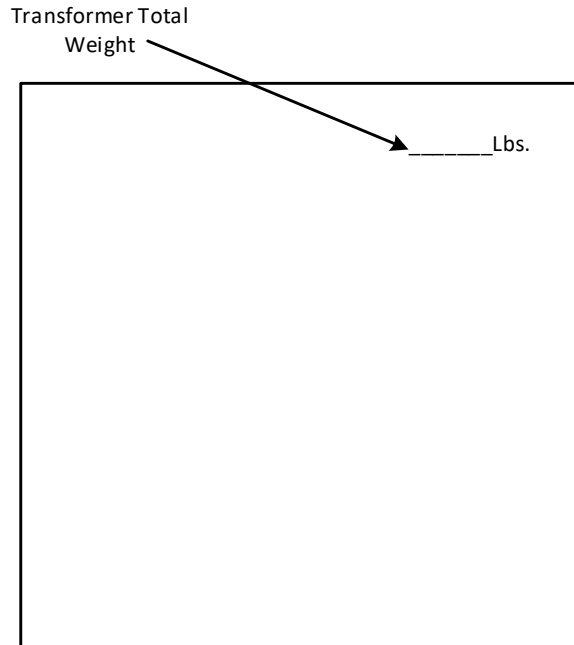

TRANSFORMER BACK VIEW

FIGURE 5

9.5"

**! WARNING**

**Hazardous voltage. KEEP OUT!**

Can shock, burn or cause death. If this enclosure is found unlocked, open or damaged, immediately call:

**PECO ENERGY COMPANY**  
1-800-494-4000



**! ¡ADVERTENCIA!**

**Alto Voltaje Adentro. NO ACERCARSE!**

Puede electrocutar, quemar o causar muerte. Si este cerco es encontrado sin trancar, abierto o dañado, llame inmediatamente a:

**PECO ENERGY COMPANY**  
1-800-494-4000



**! WARNING**

Underground power cables are located in this area.



**BEFORE YOU DIG-DRILL-BLAST**  
PA ONE CALL SYSTEM  
1-800-242-1776  
PA LAW REQUIRES ADVANCED NOTIFICATION

Can shock, burn or cause death.



**! ¡ADVERTENCIA!**

Cables subterráneos de alto voltaje existen en esta area.



**ANTES DE QUE USTED EXCAVE - PERFORE - EXPLOTE**  
LLAME AL SISTEMA DE LLAMADAS PA ONE  
1-800-242-1776  
LA LEY DEL PA REQUIERE LA NOTIFICACIÓN AVANZADA

Puede electrocutar, quemar o causar muerte.



11.5"

**NOTICE**

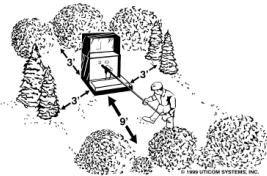

We need room to work safely on this device. Please keep shrubs and structures 9 feet away from the side with doors and 3 feet from other sides.

Obstructions may be damaged or removed during service restoration or maintenance.

**AVISO**

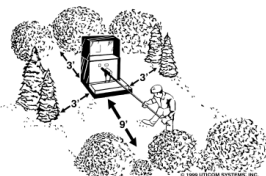

Necesitamos espacio suficiente para trabajar sin riesgos en este aparato. Por favor mantenga arbustos y estructuras a 9 pies de las puertas y 3 pies de los lados.

Estas obstrucciones podrán ser dañadas o removidas durante la restauración del servicio o mantenimiento.

▲ US1 U139-84563-C

## **EXHIBIT 3**

# **PECO ENERGY COMPANY**

## **MATERIAL SPECIFICATION**

### **133 - P- 401**

#### **SINGLE-PHASE PADMOUNTED DISTRIBUTION TRANSFORMERS**

#### **1.0 Scope**

1.1 This specification covers the requirements for 60 Hertz, mineral-oil-filled, self-cooled, single-phase, padmounted distribution transformers.

1.2 The transformers are classified as follows:

1.2.1 4kV - transformer shall operate on the 4kV distribution voltage system

1.2.2 13kV - transformer shall operate on the 13kV distribution voltage system

1.2.3 34kV - transformer shall operate on the 34kV distribution voltage system

1.2.4 DV - transformer is a dual-voltage unit, capable of operating on two different distribution voltage systems (unit is classified at the higher voltage class)

1.3 Transformers furnished under this specification shall be constructed in accordance with the requirements of the Institute of Electrical and Electronics Institute (IEEE) Standard for Pad-Mounted, Type, Self-cooled, Single-Phase Distribution Transformers; High Voltage, 34 500 GrdY/ 19 920 V and Below; Low Voltage, 240/120 V; 167 kVA and Smaller", C57.12.38 - 2014 and any other applicable IEEE standards.

Transformers with an output voltage of 600 V or less shall also be constructed in accordance with the Department of Energy - Code of Federal Regulations (CRF) 10CFR Part 431 - Energy Conservation Program: Energy Conservation Standards for Distribution Transformers.

1.3.1 Exceptions to the IEEE standards are provided for within this specification.

#### **2.0 Ratings and Polarity**

2.1 Kilovolt-Ampere Ratings

2.2.1 The KVA ratings for single-phase padmounted distribution transformers are specified in TABLE 1.

2.2 Voltage and Tap Ratings

2.2.1 The voltage rating shall be as defined in TABLE 1.

2.2.2 No taps shall be provided.

2.3 Polarity

2.3.1 The polarity of the transformers shall conform to all IEEE standards. Dual-voltage units shall have the polarity of the higher voltage.

#### **3.0 Basic Impulse Insulation Level (BIL)**

3.1 All components of the high-voltage system shall have a minimum BIL as stated below:

**34kV - 150kV BIL**

**13kV - 95kV BIL**

**4kV - 60kV BIL**

3.2 If the unit is a dual-voltage unit, both high-voltage settings (series and multiple) shall have the higher BIL rating.

3.2.1 The high voltage winding on 19.2kV X 2.4kV dual voltage units shall be designed for 150kV BIL in both positions. The vendor shall submit dielectric test data done according to ANSI/IEEE design level test procedures with the bid or must be pre-qualified before the bid. The dielectric tests shall include Hi-Pot and Chopped Wave tests.

#### 4.0 Design

4.1 The following applies to units designated as Dual Voltage (DV):

4.1.1 The transformers in TABLE 1 designated as DV units shall be designed for series-multiple operation of the high-voltage winding. The series rating shall be the higher voltage and the multiple rating shall be the lower voltage.

<u>UNIT</u>	<u>HIGH</u>	<u>LOW</u>
34 X 4	34kV	4kV

4.1.2 The high-voltage rating shall be capable of being changed by means of an externally operated dual-voltage switch.

4.1.3 It is preferred that the BIL rating at the lower voltage be achieved by winding design alone. Consideration will be given to alternate winding configurations that also achieve the dual voltage rating and maintain the BIL of the higher voltage, provided the voltage could be changed with an externally operated switch. The alternate design shall not require the replacement of any components. If the design of the high voltage windings does not utilize the entire primary winding in both positions, or leaves floating windings, the design, and how the higher BIL is maintained shall be described in the approval drawings.

#### 4.2 Electrical Operation

The transformers shall be designed for primary loop feed system operation.

#### 5.0 Compartment/Enclosure Construction

##### 5.1 High-Voltage Bushings

5.1.1 Two 200 Amp, three-phase rated, high-voltage, loadbreak, insulated, separable, connector bushings shall be provided on the transformer for loop feed system operation.

5.1.2 The following applies to units designated as 34kV Class (including DV units):

5.1.2.1 The bushings shall be 21.1kV phase-to-ground/36.6kV phase-to-phase rated, integral, loadbreak bushings. The bushings shall be either ERMCO Part # **9U02DBC001** or Cooper Power Systems # **2637024C01M**.

5.1.2.2 The bushings shall be externally replaceable. The bushings shall be externally clamped and the leads shall have sufficient slack to allow the bushing to be disconnected.

5.1.2.3 The bushing clamps shall have a four (4) studs configuration.

5.1.3 The following applies to units designated as 4kV and 13kV Class:

5.1.3.1 The bushings shall be 8.3kV phase-to-ground/14.4kV phase-to-phase rated, loadbreak bushings. The bushings shall be either integral bushings or wells with inserts.

5.1.3.2 The integral bushings or bushing wells shall be externally replaceable. The integral bushings or bushing wells shall be externally clamped and the leads shall have sufficient slack to allow the bushing to be disconnected.

- 5.1.4 Weather-tight protective caps shall be installed on the loadbreak bushings to provide protection during transportation and storage.
- 5.1.5 The make and model of the high-voltage bushings shall be shown on drawings to be reviewed and approved by PECO Energy Company.

5.2 Low Voltage and Neutral Terminals and Bushings

- 5.2.1 The low-voltage terminals shall have a minimum number of useable NEMA spaced holes per phase as follows:

<u>KVA</u>	<u>Minimum Number of Useable NEMA Spaced Holes</u>
25 & 50	6
75, 100 & 167	8

- 5.2.2 The low-voltage neutral shall have a fully insulated bushing and shall not be internally connected to the ground or to the tank. The terminal shall be an externally replaceable "H" spade and connected to the tank with an external jumper. The jumper shall be made of corrosion resistant material and be electrically equivalent to #4 AWG copper wire or greater.
- 5.2.3 The low-voltage and neutral bushings shall be externally replaceable. The low-voltage and neutral bushings shall be externally clamped and the bushing leads shall include sufficient slack to allow the bushings to be disconnected.
- 5.2.4 The low-voltage and neutral terminals shall conform to Figure 6 of IEEE Std. C57.12.38 - 2014 and shall be plated or tinned to be compatible with copper or aluminum connectors.
- 5.2.5 The low-voltage and neutral bushings shall be designed to withstand the weight and/or vertical movement due to expansion and contraction of the low-voltage cables.
- 5.2.6 The make and model of the low-voltage and neutral terminals and bushings shall be shown on drawings to be reviewed and approved by PECO Energy Company.

5.3 Dimensions

- 5.3.1 Clearance above the parking stands shall be sufficient to allow for the use of "feed-throughs".
- 5.3.2 The minimum base of all transformers shall be 28 inches wide and 34 inches deep.
- 5.3.3 The maximum base of all transformers shall be 37 inches wide and 43 inches deep.
- 5.3.4 The maximum height is as follows:
  - 26 inches - all 4kV and 13kV Class transformers 75kVA and smaller
  - 34 inches - all 4kV and 13kV Class transformers 100kVA and 167kVA
  - 36 inches - all 34kV Class transformers 75kVA and smaller
  - 40 inches - all 34kV Class transformers 100kVA and 167kVA
- 5.3.5 The maximum height of the sill shall be 6.5 inches.

5.4 Compartment Arrangement and Door

- 5.4.1 All 4kV and 13kV transformers shall have the TYPE 2 compartment arrangement as in Figure 3 of IEEE Std. C57.12.38 - 2014.
- 5.4.2 All 34kV transformers shall have the TYPE 1 compartment arrangement as in Figure 2 of IEEE Std. C57.12.38 - 2014.
- 5.4.3 A single "flip-top" type compartment door shall be provided.
- 5.4.4 The compartment door shall be hinged at the top of the tank and shall be capable of being removed only when fully open.

- 5.4.5 The compartment door shall be secured in the closed position with a captive and recessed pentahead bolt.
- 5.4.6 The compartment door padlock provisions shall be approved by PECO Energy Company prior to the manufacture of the transformers.
- 5.4.7 A 21/64" hole shall be pre-drilled as shown in FIGURE 1 on the compartment door. The hole shall be secured with a carriage bolt to prevent access inside the compartment from the outside.
- 5.4.8 The compartment door shall have the PECO Energy Company stock code number for the required bayonet fuse stenciled on the inside of the compartment door as described in Section 6.6.5. The characters shall be at least one inch high and oriented so as to be readable when opening the door.

## 5.5 Tank Grounding Connection

- 5.5.1 Two vise type, ground connectors shall be provided, near the bottom of the faceplate, to permit connection of a ground conductor to the transformer tank. The connectors shall be corrosion resistant and shall each accommodate #2 AWG copper or aluminum conductors.

## 5.6 Hold - Down Provisions

- 5.6.1 Two hold-down cleats shall be provided to secure the transformer to its foundation or pad. The cleats shall only be accessible when the compartment door is open.

## 5.7 Transformer Dielectric Fluid

- 5.7.1 The transformer shall be mineral oil filled.
- 5.7.2 The oil shall be PCB free, defined as less than 2 PPM.
- 5.7.3 A PCB free label shall be affixed on the on the compartment door as shown in FIGURE 2 of this specification.

## 5.8 Coating System

- 5.8.1 The transformer enclosure shall be finished with a topcoat color Munsell Number 7GY 3.29/1.5 pad-mount green in accordance with IEEE Std. C57.12.28 - 2014.

## 5.9 Oil Fill In/Level Plug

- 5.9.1 The oil fill in/level plug shall be 1" in diameter.

## **6.0 Accessories**

### 6.1 Overcurrent Protection

- 6.1.1 The transformer shall be equipped with a coordinated set of loadbreak bayonet and partial range current limiting fuses. The bayonet fuse for each KVA and voltage is specified in TABLE 2. Dual voltage units shall be supplied with the bayonet fuse for the lower voltage selection.
- 6.1.2 The bayonet expulsion fuse assembly shall be a Cooper Power Systems model 4000361C99FV.
- 6.1.3 The loadbreak rated bayonet fuse holder shall be physically located in the upper left hand corner of the high-voltage segment.
- 6.1.4 A drip tray shall be provided for the bayonet fuse. The tray shall be installed in such a manner to allow the tray to be removed without affecting the bayonet holder.

6.1.5 The manufacturer shall select partial range current limiting fuse(s) to coordinate with the bayonet fuse. The crossover point between the bayonet and current limiting fuse maximum clear curves shall be greater than the maximum fault current according to the following calculation:

$$\text{Maximum Fault Current} = \frac{\text{Full Load Current} \times 100 \times 1.25}{\text{Percent Impedance}}$$

The manufacturer shall coordinate the bayonet and partial range current limiting fuses for all voltages such that the current limiting fuse will not be damaged by an overload or secondary faults.

6.1.6 The electrical connection of the fuses and the surge arrester, if applicable, shall be as outlined in FIGURE 1 of this specification. The bayonet fuse shall be electrically located between the current limiting fuse and the high voltage winding.

6.1.7 All parts and locations of the overcurrent protection system for the transformer and the minimum impedance shall be shown on the drawings to be approved by PECO Energy Company prior to the manufacture of the transformers.

6.1.8 Units designated as 34kV DV shall be shipped with the appropriate bayonet fuses installed for the lower voltage connection (4kV). A bayonet fuse for the higher voltage class (34kV) shall be fastened inside the compartment, and shipped with the transformer.

6.1.9 The manufacturer shall supply a Time-Current Curve (TCC) for each transformer stock number. Each TCC shall have all the components of the overcurrent protection system and must include the transformer damage curve and the bayonet and partial current limiting fuses' min. and max melting curves. The TCCs shall be submitted to PECO Energy Company for approval prior to the manufacture of the transformers.

6.2 Primary Surge Arrester

6.2.1 For transformers that are designated as 34kV Class, a 27kV rated under-oil MOV surge arrester shall be mounted internally in the transformer.

6.2.1.1 The surge arrester supplied shall be either a Cooper Power Systems or General Electric (GE)

**Cooper**  
**AZU100L027**

**GE**  
**9L25BUK132B**

6.2.2 The ground lead of the MOV arrester shall be solidly grounded inside the tank. An arrester ground disconnect switch shall be supplied to disconnect (isolate) the ground lead from the tank for testing purposes. A label shall be located next to the arrester switch in plain view to identify the switch and its on/off positions.

6.2.3 The MOV arrester shall be protected by the current limiting and bayonet fuses.

6.3 High-Voltage, Dual-Voltage Switch (DV Units Only)

6.3.1 The transformer shall be provided with an internal, two-position, dual-voltage switch to change the high-voltage rating. The switch shall be electrically connected as shown in FIGURE 1 of this specification and select the correct fuse if internal fuses are utilized at the two high-voltage ratings.

6.3.2 The dual-voltage switch handle shall be located externally on the wall. The switch shall have positive stops to prevent handle rotation beyond the indicated switch positions.

6.3.3 The dual-voltage switch shall be equipped with a positive locking device to prevent inadvertent operation.

- 6.3.4 The dual-voltage switch positions shall be clearly marked on the tank wall with the appropriate voltage setting.
- 6.3.5 The transformer shall be shipped with the dual-voltage switch set for the “**LOW**” volt (4kV) rating. The orientation of the voltage selections on the tank wall shall be such that the pointer on the switch handle rotates in a clockwise direction to the high-voltage selection and counter-clockwise to the low-voltage selection.
- 6.3.6 All parts of the dual-voltage switch external to the tank shall be of corrosion resistant material other than aluminum.
- 6.3.7 The model/part number of the dual-voltage switch and the location of the operating handle shall be shown on drawings to be submitted to the PECO Energy Company for review and approval prior to the manufacture of the transformer.

#### 6.4 Pressure Relief Device

- 6.4.1 A pressure relief valve shall be provided with the following venting and sealing characteristics.
- 6.4.1.1 Cracking pressure 10 psig +/- 2 psig
- 6.4.1.2 Resealing pressure 6 psig minimum
- 6.4.1.3 Flow at 15 psig, 35 SCFM minimum
- 6.4.1.4 Zero leakage from reseal pressure to -8 psig

#### 6.5 Nameplate

- 6.5.1 A stainless steel Nameplate B, in accordance with IEEE Std. C57.12.00 - 2010, shall be installed inside the compartment and must include the following additional information:
- **Gallons of Oil**
  - **PECO Energy Specification Number (133-P-401)**
  - **PECO Energy Catalog id. (133-XXXXX)**
  - **The words: “DOE 2016 COMPLIANT”** (for transformers with an output voltage of 600 V or less).
- 6.5.2 The nameplate schematic diagram shall show the electrical location of all the accessories supplied with the transformer such as the dual-voltage switch and fuses. The correlation between the dual-voltage switch' positions and the transformer's voltages shall be clearly shown on the nameplate.

#### 6.6 Stenciling and Terminal Marking Requirements

- 6.6.1 The transformer's HV, LV and neutral terminal designations (i.e., H1A, H1B, X0, X1, X2 and **X3**) shall be marked on the tank wall adjacent to the terminals with a minimum of 1 - 1/2 inch minimum high yellow letters, either decal or stencil.
- 6.6.2 A 9" X 9" adhesive label containing the following information shall be affixed on the tank wall as show in FIGURE 2:
- System voltage: **4kV, 13kV, 34kV** or **4kV X 34KV** (for dual ratio units)
  - KVA value and
  - PECO Catalog ID. **133-XXXXX**

**Note:** The label for units designated as LV: 480/240 shall also contain 240/480 below the KVA value.

These labels shall be purchased from the UTICOM Company. Labels from an alternate manufacturer will not be acceptable unless approved by PECO:

6.6.3 The bayonet or full range current limiting fusing information (See Table 2 for Operating Voltage, Amp value, and PECO Energy Company stock code number for single and dual voltage units) shall be marked inside the compartment door and oriented so as to be readable when the door is opened with a 1 inch minimum high yellow letters, either decal or stencil. The following examples shall be used to stencil the bayonet fusing information.

For single voltage units:

**“USE \_\_\_ AMP BAYONET FUSE PECO CODE NUMBER 138-\_\_\_”**

For dual voltage units:

**“AT \_\_\_ kV USE \_\_\_ AMP BAYONET FUSE PECO CODE NUMBER 138-\_\_\_”**

**AT \_\_\_ kV USE \_\_\_ AMP BAYONET FUSE PECO CODE NUMBER 138-\_\_\_”**

6.6.4 Units that are designated as LV: 480/240 shall be marked as **“480/240”** on the transformer compartment door below the KVA marking with a 1-1/2 inch minimum high yellow letters, either decal or stencil.

6.6.5 Units designated as 34KV Class, including DV, units shall have a label or stencil with 1" inch minimum high black or yellow letters with the words:

6.6.5.1 **“THREE PHASE RATED BUSHINGS”** placed next to the high-voltage bushings. The label or stencil is to have a purple background (or letters) to indicate the color of the bushing nose cone.

6.6.5.2 **“INTERNAL MOV ARRESTER”** placed on the transformer tank such that it is not obstructed from view.

6.6.6 Units designated as 34kV Class, DV units only shall have the following labels or stenciling in black or yellow letters placed next to the DV switch:

6.6.6.1 Voltage settings (1 inch minimum high letters)

(High Voltage Setting)  
**19.2kV**

(Low Voltage Setting)  
**2.4kV**

6.6.6.2 **“DO NOT OPERATE WHILE ENERGIZED”** (1" inch minimum high letters)

6.6.6.3 **“WHEN CHANGING VOLTAGE SETTING CHANGE FUSE TO PROPER SIZE”** (1" inch minimum high letters)

6.6.7 A yellow **“CAUTION”** decal, with minimum 1/4" black lettering shall be affixed near the bayonet fuse and read: **“DO NOT USE BAYONET FUSE FOR LOADBREAK OPERATION IF FLOAT INDICATOR IS AT THE BOTTOM OF SIGHT GLASS”** (see Section 6.4).

6.6.8 The transformers shall be shipped with Warning/Caution/Notice and PCB labels affixed externally on the compartment door. The labels shall be located in the center of the door above the top of the sill plate as shown in FIGURE 2 of this specification.

6.6.9 The Warning/Caution/Notice label shall be in accordance with FIGURE 2 of this specification. This label will be supplied to the manufacturer upon verbal request. Contact the PECO Energy Company's Procurement Specialist to obtain a supply of labels. Two weeks advance notice is required.

6.6.10 Lower size letters on smaller KVA units may be acceptable upon PECO's approval of drawings that show the stenciling and/or labels.

6.6.11 All markings (decal or stencil) and labels shall be weather resistant.

## **7.0 Design Approval and Test Data**

### **7.1 Design Approval**

**7.1.1** The following drawings shall be submitted to PECO Energy Company for review and approval.

**7.1.1.1** An outline drawing with a detailed bill of material (BOM). The BOM shall list all part numbers including manufacturer. The drawing shall show critical tank characteristics including but not limited to the following: tank material, size, dimensions, hanger bracket type, weight, accessories (e.g. dual-voltage switch), labels, coating system, and terminal markings.

**7.1.1.2** Drawings for each of the following transformer accessories:

**7.1.1.2.1** High-voltage bushings

**7.1.1.2.2** Low-voltage bushings and terminals

**7.1.1.2.3** Neutral bushings and terminals

**7.1.1.2.4** High-voltage Dual-Voltage switch

**7.1.1.2.5** Bayonet fuse assembly

**7.1.1.2.6** Pressure Relief Valve.

**7.1.1.3** A nameplate drawing that contains the information listed in Section 6.6.

**7.1.2** All drawings, except for the part drawings, shall reference PECO Energy Company's specification number and Catalog Id. number.

**7.1.3** Revisions to any drawing previously submitted and approved shall be re-submitted to PECO Energy Company for review and approval.

### **7.2 Test Data**

**7.2.1** The manufacturer shall furnish, without cost to the PECO Energy Company, one certified copy of factory test data set for each transformer shipped. The data requirements shall include the standard, extended and calculated data sets listed in sections 4.2, 4.3 and 4.4 of IEEE Std. C57.12.37 - 2015 and transmitted to PECO Energy Company electronically (Microsoft EXCEL or compatible format) in accordance with the same standard. The price of the unit shall also be included in the standard data set.

**7.2.2** Upon request, the manufacturer shall furnish, without cost to the PECO Energy Company, one certified copy of all factory design data. Design data may include, but not limited to: electrical tests including ANSI/IEEE dielectric tests, mechanical tests (pressure relief tests, etc.), and coating/corrosion minimizing tests.

## **8.0 Compliance Requirements**

**8.1** The manufacturer shall comply with all the requirements of this specification and the Request for Proposal (RFP) covered by the Exelon Energy Delivery Purchase Order.

**8.2** Any exceptions or deviations from either this specification or the RFP requirements shall be submitted in writing by the manufacturer to PECO Energy Company for review and approval.

**8.3** Revision to drawings previously approved by PECO Energy Company, must be re-submitted to PECO Energy Company for review and approval.

## **9.0 Packing and Shipping Requirements**

**9.1** Transformers shall be firmly secured to wooden pallets for shipping. Pallets shall be made of wood with sufficient thickness as not to break under the weight of the transformer during shipment and storage, sized such that no part of the transformer extends beyond the vertical extension of the pallet's edges, and designed so that they can be picked up by a forklift truck. Transformers shall be side-loaded on open-top trucks for shipping.

**TABLE 1**

<b>SYSTEM VOLTAGE CLASS</b>	<b>DESCRIPTION</b>	<b>25kVA</b>	<b>50kVA</b>	<b>75kVA</b>	<b>100kVA</b>	<b>167kVA</b>
<b>4kV</b>	<b>HV: 4160GRDY/2400 LV: 240/120</b>	<b>133-72277</b>	<b>133-72278</b>	<b>133-72279</b>	<b>133-72280</b>	<b>133-72281</b>
<b>4kV</b>	<b>HV: 4160GRDY/2400 LV: 480/240</b>	<b>-</b>	<b>133-72282</b>	<b>-</b>	<b>-</b>	<b>-</b>
<b>13kV</b>	<b>HV: 13200GRDY/7620 LV: 240/120</b>	<b>133-71445</b>	<b>133-71446</b>	<b>133-71447</b>	<b>133-71448</b>	<b>133-71449</b>
<b>13kV</b>	<b>HV: 13200GRDY/7620 LV: 480/240</b>	<b>-</b>	<b>133-72256</b>	<b>-</b>	<b>-</b>	<b>-</b>
<b>34kV</b>	<b>HV: 33260GRDY/19200 LV: 240/120</b>	<b>-</b>	<b>133-71390</b>	<b>133-71357</b>	<b>133-71358</b>	<b>133-71359</b>
<b>34kV DV</b>	<b>HV: 4160GRDY/2400 X 33260GRDY/19200 LV: 240/120</b>	<b>133-72264</b>	<b>133-72265</b>	<b>133-72266</b>	<b>133-72267</b>	<b>133-72268</b>
<b>34kV DV</b>	<b>HV: 4160GRDY/2400 X 33260GRDY/19200 LV: 480/240</b>	<b>-</b>	<b>133-72269</b>	<b>-</b>	<b>-</b>	<b>-</b>
<b>DV - DUAL VOLTAGE UNIT</b>						

**TABLE 2****FUSING REQUIREMENTS**

<b>SYSTEM VOLTAGE CLASS</b>	<b>PECO Transformer Code Number</b>	<b>KVA Size</b>	<b>Operating Voltage</b>	<b>Fuse Size (Amp)</b>	<b>PECO Fuse Code No.</b>	<b>Bayonet Fuse Cooper Type</b>
<b>4kV</b>	133-72277	25	4 kV	25	138-29890	4000358C10
	133-72278	50	4 kV	50	138-29891	4000358C12
	133-72279	75	4 kV	100	138-29921	4000353C16
	133-72280	100	4 kV	100	138-29921	4000353C16
	133-72281	167	4 kV	140	138-29905	4000353C17
	133-72282	50	4 kV	50	138-29891	4000358C12
<b>13kV</b>	133-71445	25	13kV	8	138-29888	4000358C05
	133-71446	50	13kV	15	138-29889	4000358C08
	133-71447	75	13kV	40	138-29920	4000353C12
	133-71448	100	13kV	40	138-29920	4000353C12
	133-71449	167	13kV	50	138-29891	4000358C12
	133-72256	50	13kV	15	138-29889	4000358C08
<b>34kV</b>	133-71390	50	34 kV	8	138-29888	4000358C05
	133-71357	75	34 kV	8	138-29888	4000358C05
	133-71358	100	34 kV	15	138-29889	4000358C08
	133-71359	167	34 kV	25	138-29890	4000358C10
<b>34kV DV</b>	133-72264	25	4 kV	25	138-29890	4000358C10
			34 kV	3	138-29887	4000358C03
	133-72265	50	4 kV	50	138-29891	4000358C12
			34 kV	8	138-29888	4000358C05
	133-72266	75	4 kV	100	138-29921	4000353C16
			34 kV	8	138-29888	4000358C05
	133-72267	100	4 kV	100	138-29921	4000353C16
			34 kV	15	138-29889	4000358C08
	133-72268	167	4 kV	140	138-29905	4000353C17
			34 kV	25	138-29890	4000358C10
133-72269	50	4 kV	50	138-29891	4000358C12	
		34 kV	8	138-29888	4000358C05	

# FIGURE 1

SINGLE PHASE  
PADMOUNTED TRANSFORMER

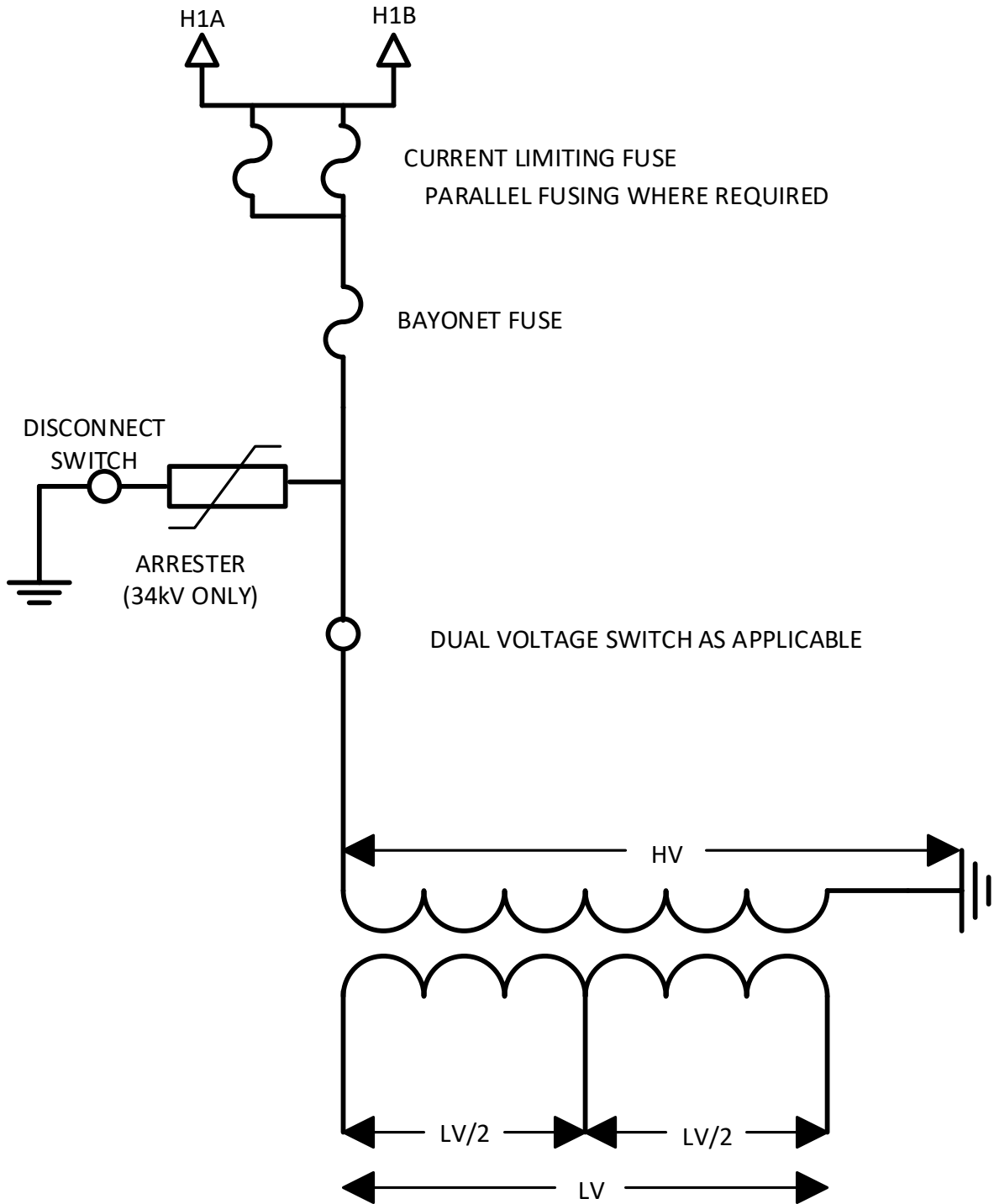

## FIGURE 2

### SINGLE-PHASE PADMOUNTED TRANSFORMER

#### EXTERNAL LABELING REQUIREMENTS

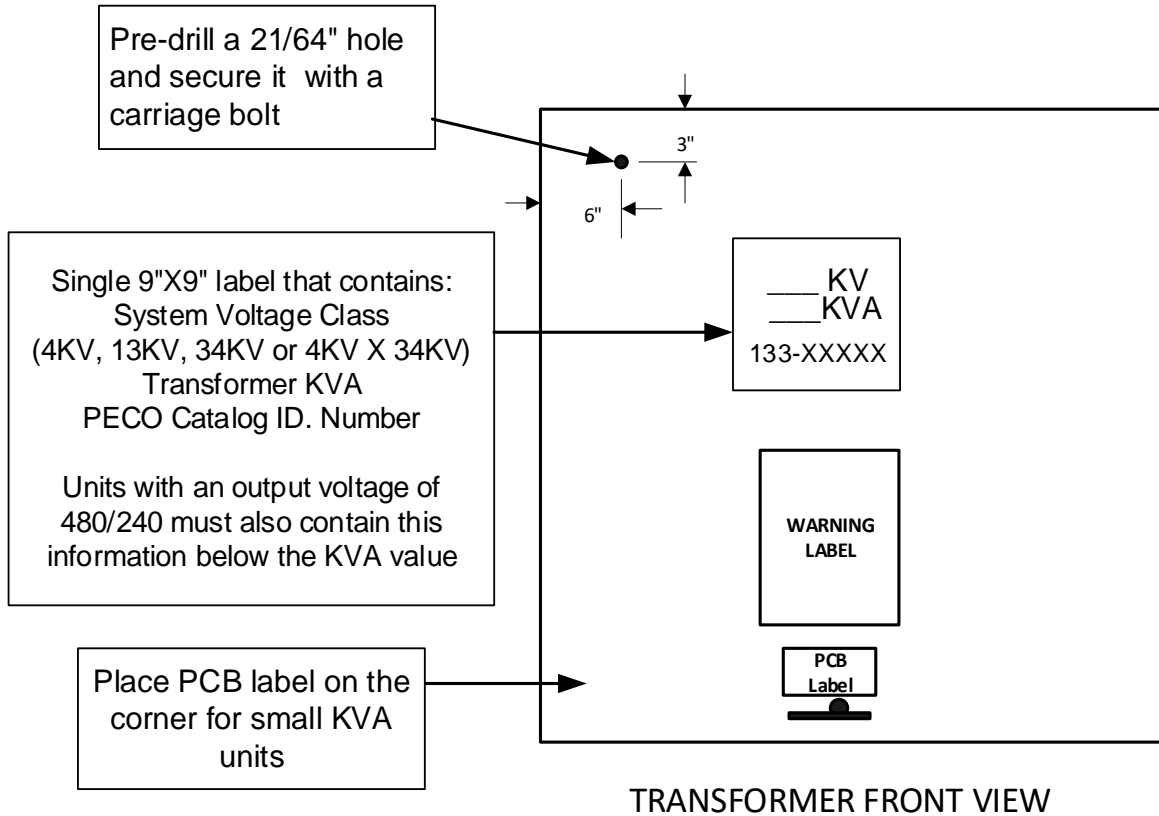

FIGURE 2

9.5"

**! WARNING**

**Hazardous voltage. KEEP OUT!**

Can shock, burn or cause death. If this enclosure is found unlocked, open or damaged, immediately call:

**PECO ENERGY COMPANY**  
1-800-494-4000



**! ¡ADVERTENCIA!**

**Alto Voltaje Adentro. NO ACERCARSE!**

Puede electrocutar, quemar o causar muerte. Si este cerco es encontrado sin trancar, abierto o dañado, llame inmediatamente a:

**PECO ENERGY COMPANY**  
1-800-494-4000



**! WARNING**

Underground power cables are located in this area.



**BEFORE YOU DIG-DRILL-BLAST**

**PA ONE CALL SYSTEM**  
1-800-242-1776  
PA LAW REQUIRES ADVANCED NOTIFICATION



Can shock, burn or cause death.

**! ¡ADVERTENCIA!**

Cables subterráneos de alto voltaje existen en esta area.



**ANTES DE QUE USTED EXCAVE - PERFORE - EXPLOTE**

**LLAME AL SISTEMA DE LLAMADAS PA ONE**  
1-800-242-1776  
LA LEY DEL PA REQUIERE LA NOTIFICACIÓN AVANZADA



Puede electrocutar, quemar o causar muerte.

11.5"

**NOTICE**

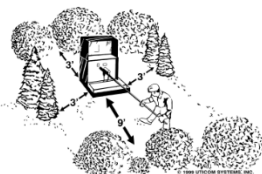

We need room to work safely on this device. Please keep shrubs and structures 9 feet away from the side with doors and 3 feet from other sides.

Obstructions may be damaged or removed during service restoration or maintenance.

**AVISO**

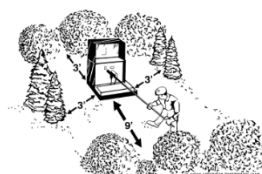

Necesitamos espacio suficiente para trabajar sin riesgos en este aparato. Por favor mantenga arbustos y estructuras a 9 pies de las puertas y 3 pies de los lados.

Estas obstrucciones podrán ser dañadas o removidas durante la restauración del servicio o mantenimiento.

▲ USI U139-84563-C

# **EXHIBIT 3**

# **PECO ENERGY COMPANY**

## **MATERIAL SPECIFICATION**

### **133 - P- 401**

#### **SINGLE-PHASE PADMOUNTED DISTRIBUTION TRANSFORMERS**

#### **1.0 Scope**

1.1 This specification covers the requirements for 60 Hertz, mineral-oil-filled, self-cooled, single-phase, padmounted distribution transformers.

1.2 The transformers are classified as follows:

1.2.1 4kV - transformer shall operate on the 4kV distribution voltage system

1.2.2 13kV - transformer shall operate on the 13kV distribution voltage system

1.2.3 34kV - transformer shall operate on the 34kV distribution voltage system

1.2.4 DV - transformer is a dual-voltage unit, capable of operating on two different distribution voltage systems (unit is classified at the higher voltage class)

1.3 Transformers furnished under this specification shall be constructed in accordance with the requirements of the Institute of Electrical and Electronics Institute (IEEE) Standard for Pad-Mounted, Type, Self-cooled, Single-Phase Distribution Transformers; High Voltage, 34 500 GrdY/ 19 920 V and Below; Low Voltage, 240/120 V; 167 kVA and Smaller", C57.12.38 - 2014 and any other applicable IEEE standards.

Transformers with an output voltage of 600 V or less shall also be constructed in accordance with the Department of Energy - Code of Federal Regulations (CRF) 10CFR Part 431 - Energy Conservation Program: Energy Conservation Standards for Distribution Transformers.

1.3.1 Exceptions to the IEEE standards are provided for within this specification.

#### **2.0 Ratings and Polarity**

2.1 Kilovolt-Ampere Ratings

2.2.1 The KVA ratings for single-phase padmounted distribution transformers are specified in TABLE 1.

2.2 Voltage and Tap Ratings

2.2.1 The voltage rating shall be as defined in TABLE 1.

2.2.2 No taps shall be provided.

2.3 Polarity

2.3.1 The polarity of the transformers shall conform to all IEEE standards. Dual-voltage units shall have the polarity of the higher voltage.

#### **3.0 Basic Impulse Insulation Level (BIL)**

3.1 All components of the high-voltage system shall have a minimum BIL as stated below:

**34kV - 150kV BIL**

**13kV - 95kV BIL**

**4kV - 60kV BIL**

3.2 If the unit is a dual-voltage unit, both high-voltage settings (series and multiple) shall have the higher BIL rating.

3.2.1 The high voltage winding on 19.2kV X 2.4kV dual voltage units shall be designed for 150kV BIL in both positions. The vendor shall submit dielectric test data done according to ANSI/IEEE design level test procedures with the bid or must be pre-qualified before the bid. The dielectric tests shall include Hi-Pot and Chopped Wave tests.

#### **4.0 Design**

4.1 The following applies to units designated as Dual Voltage (DV):

4.1.1 The transformers in TABLE 1 designated as DV units shall be designed for series-multiple operation of the high-voltage winding. The series rating shall be the higher voltage and the multiple rating shall be the lower voltage.

<u>UNIT</u>	<u>HIGH</u>	<u>LOW</u>
34 X 4	34kV	4kV

4.1.2 The high-voltage rating shall be capable of being changed by means of an externally operated dual-voltage switch.

4.1.3 It is preferred that the BIL rating at the lower voltage be achieved by winding design alone. Consideration will be given to alternate winding configurations that also achieve the dual voltage rating and maintain the BIL of the higher voltage, provided the voltage could be changed with an externally operated switch. The alternate design shall not require the replacement of any components. If the design of the high voltage windings does not utilize the entire primary winding in both positions, or leaves floating windings, the design, and how the higher BIL is maintained shall be described in the approval drawings.

#### 4.2 Electrical Operation

The transformers shall be designed for primary loop feed system operation.

#### **5.0 Compartment/Enclosure Construction**

##### 5.1 High-Voltage Bushings

5.1.1 Two 200 Amp, three-phase rated, high-voltage, loadbreak, insulated, separable, connector bushings shall be provided on the transformer for loop feed system operation.

5.1.2 The following applies to units designated as 34kV Class (including DV units):

5.1.2.1 The bushings shall be 21.1kV phase-to-ground/36.6kV phase- to-phase rated, integral, loadbreak bushings. The bushings shall be either ERMCO Part # **9U02DBC001** or Cooper Power Systems # **2637024C01M**.

5.1.2.2 The bushings shall be externally replaceable. The bushings shall be externally clamped and the leads shall have sufficient slack to allow the bushing to be disconnected.

5.1.2.3 The bushing clamps shall have a four (4) studs configuration.

5.1.3 The following applies to units designated as 4kV and 13kV Class:

5.1.3.1 The bushings shall be 8.3kV phase-to-ground/14.4kV phase-to-phase rated, loadbreak bushings. The bushings shall be either integral bushings or wells with inserts.

5.1.3.2 The integral bushings or bushing wells shall be externally replaceable. The integral bushings or bushing wells shall be externally clamped and the leads shall have sufficient slack to allow the bushing to be disconnected.

- 5.1.4 Weather-tight protective caps shall be installed on the loadbreak bushings to provide protection during transportation and storage.
- 5.1.5 The make and model of the high-voltage bushings shall be shown on drawings to be reviewed and approved by PECO Energy Company.

5.2 Low Voltage and Neutral Terminals and Bushings

- 5.2.1 The low-voltage terminals shall have a minimum number of useable NEMA spaced holes per phase as follows:

<u>KVA</u>	<u>Minimum Number of Useable NEMA Spaced Holes</u>
25 & 50	6
75, 100 & 167	8

- 5.2.2 The low-voltage neutral shall have a fully insulated bushing and shall not be internally connected to the ground or to the tank. The terminal shall be an externally replaceable "H" spade and connected to the tank with an external jumper. The jumper shall be made of corrosion resistant material and be electrically equivalent to #4 AWG copper wire or greater.
- 5.2.3 The low-voltage and neutral bushings shall be externally replaceable. The low-voltage and neutral bushings shall be externally clamped and the bushing leads shall include sufficient slack to allow the bushings to be disconnected.
- 5.2.4 The low-voltage and neutral terminals shall conform to Figure 6 of IEEE Std. C57.12.38 - 2014 and shall be plated or tinned to be compatible with copper or aluminum connectors.
- 5.2.5 The low-voltage and neutral bushings shall be designed to withstand the weight and/or vertical movement due to expansion and contraction of the low-voltage cables.
- 5.2.6 The make and model of the low-voltage and neutral terminals and bushings shall be shown on drawings to be reviewed and approved by PECO Energy Company.

5.3 Dimensions

- 5.3.1 Clearance above the parking stands shall be sufficient to allow for the use of "feed-throughs".
- 5.3.2 The minimum base of all transformers shall be 28 inches wide and 34 inches deep.
- 5.3.3 The maximum base of all transformers shall be 37 inches wide and 43 inches deep.
- 5.3.4 The maximum height is as follows:
  - 26 inches - all 4kV and 13kV Class transformers 75kVA and smaller
  - 34 inches - all 4kV and 13kV Class transformers 100kVA and 167kVA
  - 36 inches - all 34kV Class transformers 75kVA and smaller
  - 40 inches - all 34kV Class transformers 100kVA and 167kVA
- 5.3.5 The maximum height of the sill shall be 6.5 inches.

5.4 Compartment Arrangement and Door

- 5.4.1 All 4kV and 13kV transformers shall have the TYPE 2 compartment arrangement as in Figure 3 of IEEE Std. C57.12.38 - 2014.
- 5.4.2 All 34kV transformers shall have the TYPE 1 compartment arrangement as in Figure 2 of IEEE Std. C57.12.38 - 2014.
- 5.4.3 A single "flip-top" type compartment door shall be provided.
- 5.4.4 The compartment door shall be hinged at the top of the tank and shall be capable of being removed only when fully open.

- 5.4.5 The compartment door shall be secured in the closed position with a captive and recessed pentahead bolt.
- 5.4.6 The compartment door padlock provisions shall be approved by PECO Energy Company prior to the manufacture of the transformers.
- 5.4.7 A 21/64" hole shall be pre-drilled as shown in FIGURE 1 on the compartment door. The hole shall be secured with a carriage bolt to prevent access inside the compartment from the outside.
- 5.4.8 The compartment door shall have the PECO Energy Company stock code number for the required bayonet fuse stenciled on the inside of the compartment door as described in Section 6.6.5. The characters shall be at least one inch high and oriented so as to be readable when opening the door.

## 5.5 Tank Grounding Connection

- 5.5.1 Two vise type, ground connectors shall be provided, near the bottom of the faceplate, to permit connection of a ground conductor to the transformer tank. The connectors shall be corrosion resistant and shall each accommodate #2 AWG copper or aluminum conductors.

## 5.6 Hold - Down Provisions

- 5.6.1 Two hold-down cleats shall be provided to secure the transformer to its foundation or pad. The cleats shall only be accessible when the compartment door is open.

## 5.7 Transformer Dielectric Fluid

- 5.7.1 The transformer shall be mineral oil filled.
- 5.7.2 The oil shall be PCB free, defined as less than 2 PPM.
- 5.7.3 A PCB free label shall be affixed on the on the compartment door as shown in FIGURE 2 of this specification.

## 5.8 Coating System

- 5.8.1 The transformer enclosure shall be finished with a topcoat color Munsell Number 7GY 3.29/1.5 pad-mount green in accordance with IEEE Std. C57.12.28 - 2014.

## 5.9 Oil Fill In/Level Plug

- 5.9.1 The oil fill in/level plug shall be 1" in diameter.

## **6.0 Accessories**

### 6.1 Overcurrent Protection

- 6.1.1 The transformer shall be equipped with a coordinated set of loadbreak bayonet and partial range current limiting fuses. The bayonet fuse for each KVA and voltage is specified in TABLE 2. Dual voltage units shall be supplied with the bayonet fuse for the lower voltage selection.
- 6.1.2 The bayonet expulsion fuse assembly shall be a Cooper Power Systems model 4000361C99FV.
- 6.1.3 The loadbreak rated bayonet fuse holder shall be physically located in the upper left hand corner of the high-voltage segment.
- 6.1.4 A drip tray shall be provided for the bayonet fuse. The tray shall be installed in such a manner to allow the tray to be removed without affecting the bayonet holder.

6.1.5 The manufacturer shall select partial range current limiting fuse(s) to coordinate with the bayonet fuse. The crossover point between the bayonet and current limiting fuse maximum clear curves shall be greater than the maximum fault current according to the following calculation:

$$\text{Maximum Fault Current} = \frac{\text{Full Load Current} \times 100 \times 1.25}{\text{Percent Impedance}}$$

The manufacturer shall coordinate the bayonet and partial range current limiting fuses for all voltages such that the current limiting fuse will not be damaged by an overload or secondary faults.

6.1.6 The electrical connection of the fuses and the surge arrester, if applicable, shall be as outlined in FIGURE 1 of this specification. The bayonet fuse shall be electrically located between the current limiting fuse and the high voltage winding.

6.1.7 All parts and locations of the overcurrent protection system for the transformer and the minimum impedance shall be shown on the drawings to be approved by PECO Energy Company prior to the manufacture of the transformers.

6.1.8 Units designated as 34kV DV shall be shipped with the appropriate bayonet fuses installed for the lower voltage connection (4kV). A bayonet fuse for the higher voltage class (34kV) shall be fastened inside the compartment, and shipped with the transformer.

6.1.9 The manufacturer shall supply a Time-Current Curve (TCC) for each transformer stock number. Each TCC shall have all the components of the overcurrent protection system and must include the transformer damage curve and the bayonet and partial current limiting fuses' min. and max melting curves. The TCCs shall be submitted to PECO Energy Company for approval prior to the manufacture of the transformers.

6.2 Primary Surge Arrester

6.2.1 For transformers that are designated as 34kV Class, a 27kV rated under-oil MOV surge arrester shall be mounted internally in the transformer.

6.2.1.1 The surge arrester supplied shall be either a Cooper Power Systems or General Electric (GE)

**Cooper**  
**AZU100L027**

**GE**  
**9L25BUK132B**

6.2.2 The ground lead of the MOV arrester shall be solidly grounded inside the tank. An arrester ground disconnect switch shall be supplied to disconnect (isolate) the ground lead from the tank for testing purposes. A label shall be located next to the arrester switch in plain view to identify the switch and its on/off positions.

6.2.3 The MOV arrester shall be protected by the current limiting and bayonet fuses.

6.3 High-Voltage, Dual-Voltage Switch (DV Units Only)

6.3.1 The transformer shall be provided with an internal, two-position, dual-voltage switch to change the high-voltage rating. The switch shall be electrically connected as shown in FIGURE 1 of this specification and select the correct fuse if internal fuses are utilized at the two high-voltage ratings.

6.3.2 The dual-voltage switch handle shall be located externally on the wall. The switch shall have positive stops to prevent handle rotation beyond the indicated switch positions.

6.3.3 The dual-voltage switch shall be equipped with a positive locking device to prevent inadvertent operation.

- 6.3.4 The dual-voltage switch positions shall be clearly marked on the tank wall with the appropriate voltage setting.
- 6.3.5 The transformer shall be shipped with the dual-voltage switch set for the “**LOW**” volt (4kV) rating. The orientation of the voltage selections on the tank wall shall be such that the pointer on the switch handle rotates in a clockwise direction to the high-voltage selection and counter-clockwise to the low-voltage selection.
- 6.3.6 All parts of the dual-voltage switch external to the tank shall be of corrosion resistant material other than aluminum.
- 6.3.7 The model/part number of the dual-voltage switch and the location of the operating handle shall be shown on drawings to be submitted to the PECO Energy Company for review and approval prior to the manufacture of the transformer.

#### 6.4 Pressure Relief Device

- 6.4.1 A pressure relief valve shall be provided with the following venting and sealing characteristics.
- 6.4.1.1 Cracking pressure 10 psig +/- 2 psig
- 6.4.1.2 Resealing pressure 6 psig minimum
- 6.4.1.3 Flow at 15 psig, 35 SCFM minimum
- 6.4.1.4 Zero leakage from reseal pressure to -8 psig

#### 6.5 Nameplate

- 6.5.1 A stainless steel Nameplate B, in accordance with IEEE Std. C57.12.00 - 2010, shall be installed inside the compartment and must include the following additional information:
- **Gallons of Oil**
  - **PECO Energy Specification Number (133-P-401)**
  - **PECO Energy Catalog id. (133-XXXXX)**
  - **The words: “DOE 2016 COMPLIANT”** (for transformers with an output voltage of 600 V or less).
- 6.5.2 The nameplate schematic diagram shall show the electrical location of all the accessories supplied with the transformer such as the dual-voltage switch and fuses. The correlation between the dual-voltage switch' positions and the transformer's voltages shall be clearly shown on the nameplate.

#### 6.6 Stenciling and Terminal Marking Requirements

- 6.6.1 The transformer's HV, LV and neutral terminal designations (i.e., H1A, H1B, X0, X1, X2 and **X3**) shall be marked on the tank wall adjacent to the terminals with a minimum of 1 - 1/2 inch minimum high yellow letters, either decal or stencil.
- 6.6.2 A 9" X 9" adhesive label containing the following information shall be affixed on the tank wall as show in FIGURE 2:
- System voltage: **4kV, 13kV, 34kV** or **4kV X 34KV** (for dual ratio units)
  - KVA value and
  - PECO Catalog ID. **133-XXXXX**

**Note:** The label for units designated as LV: 480/240 shall also contain 240/480 below the KVA value.

These labels shall be purchased from the UTICOM Company. Labels from an alternate manufacturer will not be acceptable unless approved by PECO:

6.6.3 The bayonet or full range current limiting fusing information (See Table 2 for Operating Voltage, Amp value, and PECO Energy Company stock code number for single and dual voltage units) shall be marked inside the compartment door and oriented so as to be readable when the door is opened with a 1 inch minimum high yellow letters, either decal or stencil. The following examples shall be used to stencil the bayonet fusing information.

For single voltage units:

**“USE \_\_\_ AMP BAYONET FUSE PECO CODE NUMBER 138-\_\_\_”**

For dual voltage units:

**“AT \_\_\_ kV USE \_\_\_ AMP BAYONET FUSE PECO CODE NUMBER 138-\_\_\_”**

**AT \_\_\_ kV USE \_\_\_ AMP BAYONET FUSE PECO CODE NUMBER 138-\_\_\_”**

6.6.4 Units that are designated as LV: 480/240 shall be marked as **“480/240”** on the transformer compartment door below the KVA marking with a 1-1/2 inch minimum high yellow letters, either decal or stencil.

6.6.5 Units designated as 34KV Class, including DV, units shall have a label or stencil with 1" inch minimum high black or yellow letters with the words:

6.6.5.1 **“THREE PHASE RATED BUSHINGS”** placed next to the high-voltage bushings. The label or stencil is to have a purple background (or letters) to indicate the color of the bushing nose cone.

6.6.5.2 **“INTERNAL MOV ARRESTER”** placed on the transformer tank such that it is not obstructed from view.

6.6.6 Units designated as 34kV Class, DV units only shall have the following labels or stenciling in black or yellow letters placed next to the DV switch:

6.6.6.1 Voltage settings (1 inch minimum high letters)

(High Voltage Setting)  
**19.2kV**

(Low Voltage Setting)  
**2.4kV**

6.6.6.2 **“DO NOT OPERATE WHILE ENERGIZED”** (1" inch minimum high letters)

6.6.6.3 **“WHEN CHANGING VOLTAGE SETTING CHANGE FUSE TO PROPER SIZE”** (1" inch minimum high letters)

6.6.7 A yellow **“CAUTION”** decal, with minimum 1/4" black lettering shall be affixed near the bayonet fuse and read: **“DO NOT USE BAYONET FUSE FOR LOADBREAK OPERATION IF FLOAT INDICATOR IS AT THE BOTTOM OF SIGHT GLASS”** (see Section 6.4).

6.6.8 The transformers shall be shipped with Warning/Caution/Notice and PCB labels affixed externally on the compartment door. The labels shall be located in the center of the door above the top of the sill plate as shown in FIGURE 2 of this specification.

6.6.9 The Warning/Caution/Notice label shall be in accordance with FIGURE 2 of this specification. This label will be supplied to the manufacturer upon verbal request. Contact the PECO Energy Company's Procurement Specialist to obtain a supply of labels. Two weeks advance notice is required.

6.6.10 Lower size letters on smaller KVA units may be acceptable upon PECO's approval of drawings that show the stenciling and/or labels.

6.6.11 All markings (decal or stencil) and labels shall be weather resistant.

## **7.0 Design Approval and Test Data**

### **7.1 Design Approval**

**7.1.1** The following drawings shall be submitted to PECO Energy Company for review and approval.

**7.1.1.1** An outline drawing with a detailed bill of material (BOM). The BOM shall list all part numbers including manufacturer. The drawing shall show critical tank characteristics including but not limited to the following: tank material, size, dimensions, hanger bracket type, weight, accessories (e.g. dual-voltage switch), labels, coating system, and terminal markings.

**7.1.1.2** Drawings for each of the following transformer accessories:

**7.1.1.2.1** High-voltage bushings

**7.1.1.2.2** Low-voltage bushings and terminals

**7.1.1.2.3** Neutral bushings and terminals

**7.1.1.2.4** High-voltage Dual-Voltage switch

**7.1.1.2.5** Bayonet fuse assembly

**7.1.1.2.6** Pressure Relief Valve.

**7.1.1.3** A nameplate drawing that contains the information listed in Section 6.6.

**7.1.2** All drawings, except for the part drawings, shall reference PECO Energy Company's specification number and Catalog Id. number.

**7.1.3** Revisions to any drawing previously submitted and approved shall be re-submitted to PECO Energy Company for review and approval.

### **7.2 Test Data**

**7.2.1** The manufacturer shall furnish, without cost to the PECO Energy Company, one certified copy of factory test data set for each transformer shipped. The data requirements shall include the standard, extended and calculated data sets listed in sections 4.2, 4.3 and 4.4 of IEEE Std. C57.12.37 - 2015 and transmitted to PECO Energy Company electronically (Microsoft EXCEL or compatible format) in accordance with the same standard. The price of the unit shall also be included in the standard data set.

**7.2.2** Upon request, the manufacturer shall furnish, without cost to the PECO Energy Company, one certified copy of all factory design data. Design data may include, but not limited to: electrical tests including ANSI/IEEE dielectric tests, mechanical tests (pressure relief tests, etc.), and coating/corrosion minimizing tests.

## **8.0 Compliance Requirements**

**8.1** The manufacturer shall comply with all the requirements of this specification and the Request for Proposal (RFP) covered by the Exelon Energy Delivery Purchase Order.

**8.2** Any exceptions or deviations from either this specification or the RFP requirements shall be submitted in writing by the manufacturer to PECO Energy Company for review and approval.

**8.3** Revision to drawings previously approved by PECO Energy Company, must be re-submitted to PECO Energy Company for review and approval.

## **9.0 Packing and Shipping Requirements**

**9.1** Transformers shall be firmly secured to wooden pallets for shipping. Pallets shall be made of wood with sufficient thickness as not to break under the weight of the transformer during shipment and storage, sized such that no part of the transformer extends beyond the vertical extension of the pallet's edges, and designed so that they can be picked up by a forklift truck. Transformers shall be side-loaded on open-top trucks for shipping.

**TABLE 1**

<b>SYSTEM VOLTAGE CLASS</b>	<b>DESCRIPTION</b>	<b>25kVA</b>	<b>50kVA</b>	<b>75kVA</b>	<b>100kVA</b>	<b>167kVA</b>
<b>4kV</b>	<b>HV: 4160GRDY/2400 LV: 240/120</b>	<b>133-72277</b>	<b>133-72278</b>	<b>133-72279</b>	<b>133-72280</b>	<b>133-72281</b>
<b>4kV</b>	<b>HV: 4160GRDY/2400 LV: 480/240</b>	<b>-</b>	<b>133-72282</b>	<b>-</b>	<b>-</b>	<b>-</b>
<b>13kV</b>	<b>HV: 13200GRDY/7620 LV: 240/120</b>	<b>133-71445</b>	<b>133-71446</b>	<b>133-71447</b>	<b>133-71448</b>	<b>133-71449</b>
<b>13kV</b>	<b>HV: 13200GRDY/7620 LV: 480/240</b>	<b>-</b>	<b>133-72256</b>	<b>-</b>	<b>-</b>	<b>-</b>
<b>34kV</b>	<b>HV: 33260GRDY/19200 LV: 240/120</b>	<b>-</b>	<b>133-71390</b>	<b>133-71357</b>	<b>133-71358</b>	<b>133-71359</b>
<b>34kV DV</b>	<b>HV: 4160GRDY/2400 X 33260GRDY/19200 LV: 240/120</b>	<b>133-72264</b>	<b>133-72265</b>	<b>133-72266</b>	<b>133-72267</b>	<b>133-72268</b>
<b>34kV DV</b>	<b>HV: 4160GRDY/2400 X 33260GRDY/19200 LV: 480/240</b>	<b>-</b>	<b>133-72269</b>	<b>-</b>	<b>-</b>	<b>-</b>
<b>DV - DUAL VOLTAGE UNIT</b>						

**TABLE 2****FUSING REQUIREMENTS**

<b>SYSTEM VOLTAGE CLASS</b>	<b>PECO Transformer Code Number</b>	<b>KVA Size</b>	<b>Operating Voltage</b>	<b>Fuse Size (Amp)</b>	<b>PECO Fuse Code No.</b>	<b>Bayonet Fuse Cooper Type</b>
<b>4kV</b>	133-72277	25	4 kV	25	138-29890	4000358C10
	133-72278	50	4 kV	50	138-29891	4000358C12
	133-72279	75	4 kV	100	138-29921	4000353C16
	133-72280	100	4 kV	100	138-29921	4000353C16
	133-72281	167	4 kV	140	138-29905	4000353C17
	133-72282	50	4 kV	50	138-29891	4000358C12
<b>13kV</b>	133-71445	25	13kV	8	138-29888	4000358C05
	133-71446	50	13kV	15	138-29889	4000358C08
	133-71447	75	13kV	40	138-29920	4000353C12
	133-71448	100	13kV	40	138-29920	4000353C12
	133-71449	167	13kV	50	138-29891	4000358C12
	133-72256	50	13kV	15	138-29889	4000358C08
<b>34kV</b>	133-71390	50	34 kV	8	138-29888	4000358C05
	133-71357	75	34 kV	8	138-29888	4000358C05
	133-71358	100	34 kV	15	138-29889	4000358C08
	133-71359	167	34 kV	25	138-29890	4000358C10
<b>34kV DV</b>	133-72264	25	4 kV	25	138-29890	4000358C10
			34 kV	3	138-29887	4000358C03
	133-72265	50	4 kV	50	138-29891	4000358C12
			34 kV	8	138-29888	4000358C05
	133-72266	75	4 kV	100	138-29921	4000353C16
			34 kV	8	138-29888	4000358C05
	133-72267	100	4 kV	100	138-29921	4000353C16
			34 kV	15	138-29889	4000358C08
	133-72268	167	4 kV	140	138-29905	4000353C17
			34 kV	25	138-29890	4000358C10
133-72269	50	4 kV	50	138-29891	4000358C12	
		34 kV	8	138-29888	4000358C05	

# FIGURE 1

SINGLE PHASE  
PADMOUNTED TRANSFORMER

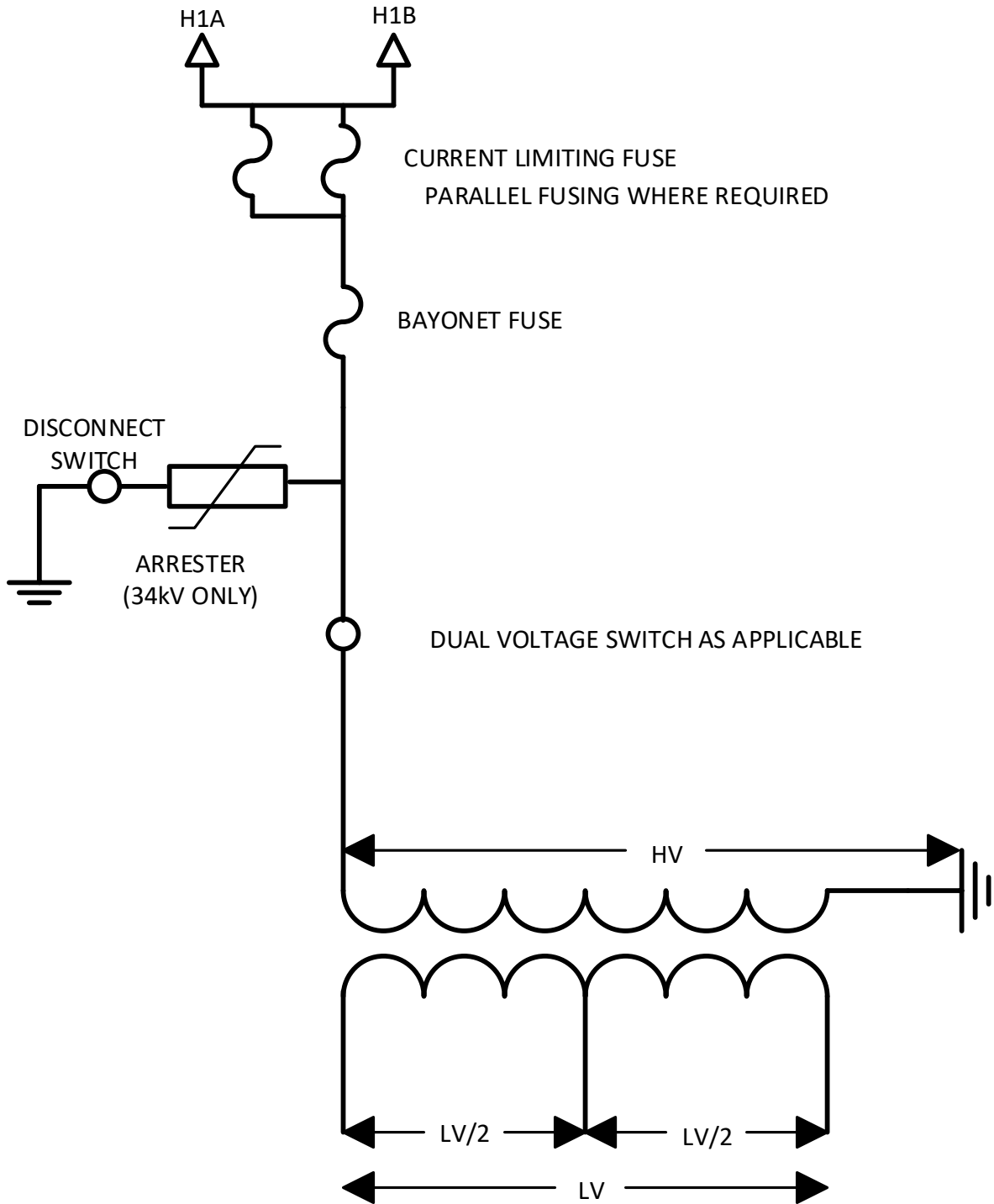

## FIGURE 2

### SINGLE-PHASE PADMOUNTED TRANSFORMER

#### EXTERNAL LABELING REQUIREMENTS

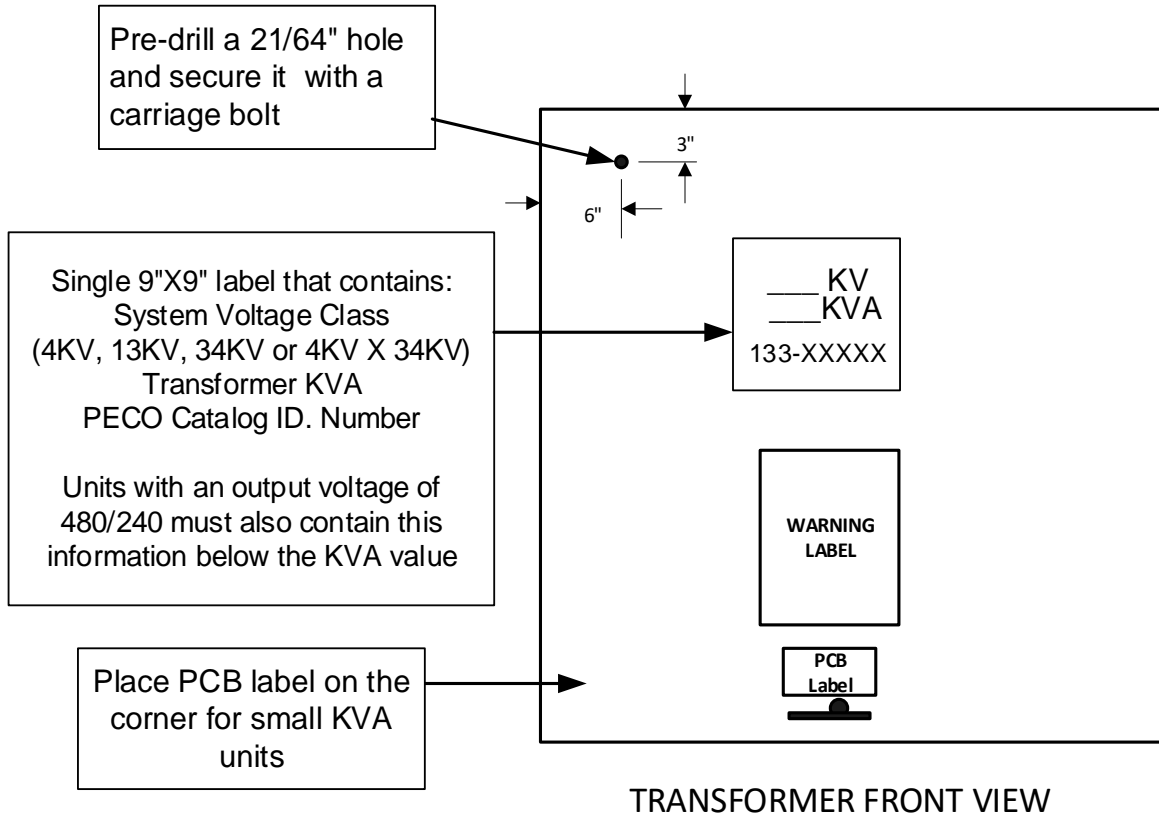

FIGURE 2

9.5"

**! WARNING**

**! ¡ADVERTENCIA!**

**Hazardous voltage. KEEP OUT!**

**Alto Voltaje Adentro. NO ACERCARSE!**

Can shock, burn or cause death. If this enclosure is found unlocked, open or damaged, immediately call:

Puede electrocutar, quemar o causar muerte. Si este cerco es encontrado sin trancar, abierto o dañado, llame inmediatamente a:

**PECO ENERGY COMPANY**  
1-800-494-4000

**PECO ENERGY COMPANY**  
1-800-494-4000



**! WARNING**

**! ¡ADVERTENCIA!**

Underground power cables are located in this area.

Cables subterráneos de alto voltaje existen en esta area.



**BEFORE YOU DIG-DRILL-BLAST**

**PA ONE CALL SYSTEM**  
1-800-242-1776  
PA LAW REQUIRES ADVANCED NOTIFICATION

**ANTES DE QUE USTED EXCAVE - PERFORE - EXPLOTE**

**LLAME AL SISTEMA DE LLAMADAS PA ONE**  
1-800-242-1776  
LA LEY DEL PA REQUIERE LA NOTIFICACIÓN AVANZADA

Can shock, burn or cause death.

Puede electrocutar, quemar o causar muerte.



**NOTICE**

**AVISO**

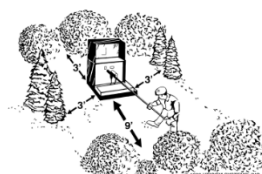
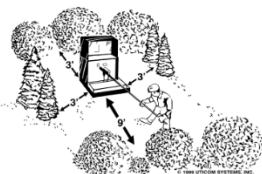

We need room to work safely on this device. Please keep shrubs and structures 9 feet away from the side with doors and 3 feet from other sides.

Necesitamos espacio suficiente para trabajar sin riesgos en este aparato. Por favor mantenga arbustos y estructuras a 9 pies de las puertas y 3 pies de los lados.

Obstructions may be damaged or removed during service restoration or maintenance.

Estas obstrucciones podrán ser dañadas o removidas durante la restauración del servicio o mantenimiento.

▲ USI U139-84563-C

11.5"

# **EXHIBIT 4**

# **PECO ENERGY COMPANY**

## **MATERIAL SPECIFICATION**

### **133 - P- 402**

#### **THREE-PHASE PADMOUNTED DISTRIBUTION TRANSFORMERS**

#### **1.0    Scope**

- 1.1    This specification covers the requirements for 60 Hertz, mineral oil-filled, self-cooled, three-phase, padmounted distribution transformers.
- 1.2    The transformers are classified as follows:
  - 1.2.1    4kV - transformer shall operate on the 4kV distribution voltage system
  - 1.2.2    13kV - transformer shall operate on the 13kV distribution voltage system
  - 1.2.3    34kV - transformer shall operate on the 34kV distribution voltage system
  - 1.2.4    DTS - transformer is designed so that the primary is connected WYE with an isolated neutral and the secondary is 240V DELTA with 120V mid-tap
  - 1.2.5    STEP - transformer is a step or interposing unit designed to operate between two different distribution systems.
- 1.3    Transformers furnished under this specification shall be constructed in accordance with the Institute of Electrical and Electronics Engineers (IEEE) Standard for Requirements for Pad-Mounted, Compartmental-Type, Self-Cooled, Three-Phase Distribution Transformers, 5 MVA and Smaller; High-Voltage: 34.5 kV Nominal System Voltage and Below; Low Voltage, 15 kV Nominal System Voltage and Below, C57.12.34 - 2015 any other applicable IEEE standards.

Transformers with an output voltage of 600 V or less shall also be constructed in accordance with the Department of Energy - Code of Federal Regulations (CRF) 10CFR Part 431 - Energy Conservation Program: Energy Conservation Standards for Distribution Transformers.

  - 1.3.1    Exceptions to the IEEE standards are provided for within this specification.

#### **2.0    Ratings**

- 2.1    Kilovolt-Ampere Ratings
  - 2.1.1    The KVA ratings for three-phase padmounted distribution transformers are specified in TABLE 1.
- 2.2    Voltage and Tap Ratings
  - 2.2.1    The voltage rating shall be as defined in TABLE 1.
  - 2.2.2    No taps shall be provided.

#### **3.0    Basic Impulse Insulation Level (BIL)**

- 3.1    All components of the high-voltage system shall have a minimum BIL as stated below:
  - 34kV - 150kV BIL**
  - 13kV - 95kV BIL**
  - 4kV - 60kV BIL**
- 3.2    For units that are designated as STEP, the low-voltage system shall have a BIL rating as specified in section 3.1.

## **4.0 Design**

### **4.1 Core and Coils**

**4.1.1** The transformers shall be designed to prevent tank heating due to fault conditions or unbalanced loads. This shall be accomplished by means of three single-phase core and coil units or five-legged core construction.

**4.1.2** The high-voltage and low-voltage coils for units designated as STEP shall be copper.

### **4.2 Low-Voltage Mid-Tap Neutral (DTS units only)**

**4.2.1** A mid-tap (X4 designation) shall be provided on the 240 Volt winding section midway (electrically) between the X1 and X2 terminals.

**4.2.2** The mid-tap lead shall have the same current carrying capacity as the low-voltage phase leads.

**4.2.3** The mid-tap bushing shall be fully insulated.

**4.2.4** A removable, external ground strap shall be connected between the X4 terminal and a ground pad located directly beneath the terminal in the low-voltage compartment.

### **4.3 Electrical Operation**

The transformers shall be designed for primary loop feed system operation.

### **4.4 Impedance**

**4.4.1** The impedance of the transformers shall be as specified in TABLE 2 of this specification.

## **5.0 Compartment/Enclosure Construction**

### **5.1 High-Voltage Bushings**

**5.1.1** Two 200 Amp, three-phase rated, high-voltage, loadbreak, insulated, separable connector bushings shall be provided per phase on the transformer for loop feed system operation.

**5.1.2** The following applies to units designated as 34kV Class:

**5.1.2.1** The bushings shall be 21.1kV phase-to-ground/36.6kV phase-to-phase rated, integral, loadbreak bushings. The bushings shall be either ERMCO **Part # 9U02DBC001** or Cooper Power Systems **Part # 2637024C01M**.

**5.1.2.2** The bushings shall be externally replaceable. The bushings shall be externally clamped and the leads shall have sufficient slack to allow the bushing to be disconnected.

**5.1.2.3** A label or stencil (minimum 1/2" height letters) with the words "**THREE PHASE RATED BUSHINGS**" shall be placed next to the high-voltage bushings. The label or stencil is to have a purple background (or letters) to indicate the color of the bushing nose cone.

**5.1.2.4** The bushing clamps shall have a four (4) studs configuration.

**5.1.3** The following applies to units designated as 4kV and 13kV Class:

**5.1.3.1** The bushings shall be 8.3kV phase-to-ground/14.4kV phase-to-phase rated, loadbreak bushings. The bushings shall be either integral bushings or bushing wells with inserts.

**5.1.3.2** The integral bushings or bushing wells shall be externally replaceable. The integral bushings or bushing wells shall be externally clamped and the leads shall have sufficient slack to allow the bushing to be disconnected.

5.1.4 Weather-tight protective caps shall be installed on the loadbreak bushings to provide protection during transportation and storage.

5.1.5 The make and model of the high-voltage bushings shall be shown on drawings to be reviewed and approved by PECO Energy Company.

5.2 Low-Voltage and Neutral Terminals and Bushings

5.2.1 The following applies to all units **except for units designated as STEP:**

5.2.1.1 The low-voltage and neutral terminals shall have a minimum number of useable NEMA spaced holes per phase as specified in the following table:

No. of Holes	Secondary Voltage			
	<u>208Y/120</u>	<u>240/120</u>	<u>240Y/139</u>	<u>480Y/277</u>
	KVA			
4	<b>75 - 150</b>	<b>75 - 150</b>	<b>150</b>	<b>150</b>
6	<b>300</b>	<b>300</b>	<b>300</b>	<b>300 - 750</b>
8	<b>500</b>	<b>500</b>	<b>500</b>	<b>1000</b>
10	-	-	<b>750</b>	-
12	<b>750</b>	-	-	<b>1500</b>
14	<b>1000</b>	-	-	-

5.2.1.2 For units designated as DTS or “floating” Y, the high-voltage neutral (H0) shall not be internally connected to ground or to the tank. The low-voltage mid-tap neutral shall be brought out externally through the X4 terminal and connected to the tank with an external jumper. The jumper shall be made of corrosion resistant material and be electrically equivalent to a minimum #4 AWG copper wire.

5.2.1.3 For units designated as “grounded” Y (GRDY) units, the high-voltage neutral (H0) and low-voltage neutral (X0) shall be connected internally through a removable link and brought out externally through the H0/X0 neutral terminal and connected to the tank with an external jumper. The jumper shall be made of corrosion resistant material and be electrically equivalent to a minimum #4 AWG copper wire. The H0/X0 removable link shall be accessible through the handhole (see 5.4.5.1).

5.2.1.4 The low-voltage and neutral terminals shall be externally replaceable.

5.2.1.5 The low-voltage and neutral terminals shall be designed to withstand the weight and/or vertical movement due to expansion and contraction of the low-voltage cables.

5.2.1.6 The low-voltage and neutral terminals provided shall conform to Figure 19 of IEEE Standard C57.12.34 -2015 and shall be plated or tinned to be compatible with copper or aluminum connectors and minimum useable NEMA spaced holes as specified in 5.2.1.1.

5.2.1.7 All transformers rated 300KVA and greater shall be furnished with additional insulated supports, designed by the manufacturer, at the end of the low-voltage terminals furthest from the tank wall. The supports shall be designed such that they will not interfere with the installation of secondary cables onto the low voltage terminals.

5.2.2 The following applies to units designated as STEP:

5.2.2.1 The low-voltage bushings shall be 8.3kV phase-to-ground/14.4kV phase to-phase rated, loadbreak bushings. The bushings shall be either integral bushings or bushing wells with inserts.

5.2.2.2 The low-voltage bushings arrangement shall be in-line type with parking stands in accordance with Figure 3 of IEEE C57.12.34 – 2015. The height of the bushings from the transformer base shall be 39” for units greater than 500KVA and 31” for units less than or equal to 500KVA. The neutral bushing (X0) shall be located 8” min. below the X1 bushing.

5.2.2.3 The integral bushings or bushing wells shall be externally replaceable. The integral bushings or bushing wells shall be externally clamped and the leads shall have sufficient slack to allow the bushing to be disconnected.

5.2.2.4 Weather-tight protective caps shall be installed on the low-voltage bushings to provide protection during transportation and storage.

5.2.2.5 The neutral terminal shall have a fully insulated bushing that is externally replaceable. The neutral terminal shall be an externally replaceable "H" spade and connected to the tank with an external jumper. The jumper shall be made of corrosion resistant material and be electrically equivalent to a minimum #4 AWG copper wire.

5.2.4 The make and model of the low-voltage and neutral terminals and bushings shall be shown on drawings to be reviewed and approved by PECO Energy Company.

### 5.3 Dimensions

5.3.1 Clearance above the parking stands shall be sufficient to allow for the use of "feed-throughs".

5.3.2 The maximum height of the sill shall be 18 inches.

5.3.3 The maximum depth, excluding cooling, of all transformer bases shall be 70 inches. The maximum width of all transformer bases shall be as follows:

<b>VOLTAGE CLASS</b>	<b>SIZE (KVA)</b>	<b>WIDTH (inches)</b>
4kV & 13 kV	750 & smaller	72
4kV & 13 kV	1000	78
34 kV	150 to 2500	84

### 5.4 Compartment Arrangement and Doors

5.4.1 The low-voltage compartment shall have, as a minimum, the dimensions and arrangement shown in Figure 8(a) of IEEE C57.12.34 - 2009.

5.4.2 The high-voltage compartment for the 4kV, 13kV and 34kV units shall conform to the dimensions and arrangements shown in FIGURES 2 and 3 of this specification.

5.4.3 The high-voltage compartment door shall be secured in the closed position with a captive, pentahead bolt. The pentahead bolt shall be accessible only after the low-voltage compartment door has been opened. The low-voltage compartment door shall also be secured in the closed position by means of a captive and recessed pentahead bolt.

5.4.4 The compartment doors shall be equipped with stops for latching in the open position.

#### 5.4.5 False Cover

5.4.5.1 A bolted handhole or main cover located on top of the transformer tank shall be made tamperproof by means of a false cover. The false cover shall be removable only after the low-voltage compartment door has been opened. The false cover shall not extend above the top of the high-voltage/low-voltage compartment.

5.4.5.2 The size of the handhole or main cover shall be reviewed and approved by PECO Energy Company prior to the manufacture of the transformers.

- 5.4.6 The compartment door padlock provisions shall be approved by PECO Energy Company prior to the manufacture of the transformers.
- 5.4.7 The high-voltage compartment door shall have the PECO Energy Company stock code number for the required bayonet fuse stenciled on the inside of the compartment door as described in Section 6.8.3 and oriented so as to be readable when opening the door.
- 5.5 Tank Grounding Connection
- 5.5.1 Two vise type, ground connectors shall be provided, near the bottom of the faceplate, to permit connection of a ground conductor to the transformer tank. The connector shall be corrosion resistant and shall accommodate two #2 AWG copper or aluminum conductors.
- 5.6 Hold - Down Provisions
- 5.6.1 Two hold-down cleats shall be provided to secure the transformer to its foundation or pad.
- 5.7 Transformer Oil
- 5.7.1 The transformer shall be mineral oil-filled.
- 5.7.2 The oil shall be PCB free, defined as less than 2 PPM.
- 5.7.3 A PCB free label shall be affixed on the on the compartment door as shown in FIGURE 2 of this specification.
- 5.8 Coating System
- 5.8.1 The transformer enclosure shall be finished with a topcoat color Munsell Number 7GY 3.29/1.5 pad-mount green in accordance with IEEE Standard C57.12.28 - 2014.

## **6.0 Accessories**

- 6.1 Overcurrent Protection
- 6.1.1 The transformer shall be equipped with a coordinated set of high-voltage loadbreak bayonet and partial range current limiting fuses to protect the system from overcurrent conditions inside the transformer. The bayonet and partial range current limiting fuse values for each KVA and voltage are specified in TABLE 2. The electrical connection (for each phase) of the fuses and gang-operated loadbreak switch, and if applicable, the surge arrester shall be as shown in FIGURE 1 attached to this specification. Any exceptions or deviations from these requirements shall be approved by the PECO Energy Company.
- 6.1.2 The bayonet expulsion fuse assembly shall be a Cooper Power System model 4000361C99FV except for the 4038361C05CB type bayonet fuse. For this bayonet type fuse, a Cooper fuse assembly model 4038804B03M shall be used.
- 6.1.3 The loadbreak rated bayonet fuse holder shall be physically located in the high-voltage compartment.
- 6.1.4 A drip tray shall be provided for the bayonet fuse. The tray shall be installed in such a manner to allow the tray to be removed without affecting the bayonet holder.
- 6.1.5 The fuse holders shall be designed to accommodate hot-line tools.
- 6.1.6 All parts and locations of the overcurrent protection for the transformer shall be shown on approval drawings sent to the PECO Energy Company.
- 6.1.7 The manufacturer shall supply a Time-Current Curve (TCC) for each transformer stock number. Each TCC shall have all the components of the overcurrent protection system and must include the transformer damage curve and the bayonet and partial current limiting fuses' min. and max melting curves. The TCCs shall be submitted to PECO Energy Company for approval prior to the manufacture of the transformers.

## 6.2 Primary Surge Arrester

6.2.1 For transformers that are designated as 34kV Class, a 27kV rated under-oil MOV surge arrester shall be mounted internally in the transformer for each phase.

6.2.1.1 The surge arrester supplied shall be either a Cooper Power Systems or General Electric type.

**Cooper**  
**AZU100L027**

**General Electric**  
**9L25BUK132B**

6.2.2 The ground lead of the surge arrester shall be solidly grounded inside the tank. An arrester ground disconnect switch shall be supplied to disconnect (isolate) the ground lead from the tank for testing purposes. A label shall be located next to the arrester switch in plain view to identify the switch and its on/off positions.

6.2.3 The MOV arresters shall be protected by the current limiting and bayonet fuses.

6.2.4 The words "**INTERNAL MOV ARRESTERS**" shall be stenciled on the transformer tank. The stenciling shall be located such that it is not obstructed from view.

## 6.3 Gang-Operated Loadbreak Switch

6.3.1 A high-voltage, gang-operated, two-position loadbreak switch shall be provided to energize and de-energize the transformer.

6.3.2 The switch shall be electrically connected as shown in FIGURE 1 of this specification.

6.3.3 The operating handle of the loadbreak switch shall be located in the high-voltage compartment in plain view in a manner as not to impede its operation with a hot-line tool. A label or stencil that reads: "**LOADBREAK SWITCH**" shall be located next to the switch in plain view.

6.3.4 The positions of the switch shall be clearly indicated.

6.3.5 The operating handle of the loadbreak switch shall be designed for hot line tools operation.

6.3.6 All parts of the high-voltage gang-operated switch external to the tank shall be of corrosion resistant material such stainless steel or solid brass. Aluminum, cast aluminum and/or plastic material **are not acceptable**.

6.3.7 The model/part number of the high-voltage gang operated switch and the location of the operating handle shall be shown on drawings to be submitted to PECO Energy Company for review and approval prior to the manufacture of the transformer.

## 6.4 Drain Valve

A drain valve with oil sampling capabilities shall be provided for all KVA size transformers and shall be located inside the high voltage compartment 6" (min.) from the centerline of the valve to the High/Low voltage barrier and at a height as to allow the oil to be completely drained from inside the tank.

## 6.5 Sight Glass

6.5.1 A sight glass, Heartland Solution Catalog No. HLG-1011 or equivalent, with corrosion resistant body and 120°C temperature rating shall be provided.

6.5.2 The sight glass shall be located inside the high voltage compartment at the minimum height where the oil is visible and it is acceptable to operate the primary loadbreak switch.

6.5.3 The sight glass shall be located at a height such that the oil level will be visible in the middle of the sight glass, at a minimum, when the ambient temperature of - 20°C and the transformer is not in service (e.g. de-energized).

## 6.6 Pressure Relief Device

6.6.1 A pressure relief valve shall be provided with the following venting and sealing characteristics.

6.6.1.1 Cracking pressure 10 psig +/- 2 psig

6.6.1.2 Resealing pressure 6 psig minimum

6.6.1.3 Flow at 15 psig, 35 SCFM minimum

6.6.1.4 Zero leakage from reseal pressure to -8 psig

## 6.7 Nameplate

6.7.1 A stainless steel Nameplate B, in accordance with IEEE Standard C57.12.00 - 2010, shall be installed inside the compartment and must include the following additional information:

- **Gallons of Oil**
- **PECO Energy Specification Number (133-P-401)**
- **PECO Energy Catalog id. (133-XXXXX)**
- **The words: "DOE 2016 COMPLIANT"** (for transformers with an output voltage of 600 V or less).

6.7.2 The nameplate schematic diagram shall show the electrical location of all the accessories supplied with the transformer such as the loadbreak switch and fuses.

## 6.8 Stenciling and Terminal Marking Requirements

6.8.1 The transformer's HV, LV and neutral terminal designations (i.e., H0, H1-3A, H1-3B, X0, X1, X2, X3 and X4) shall be marked on the tank wall adjacent to the terminals with a minimum of 1-1/2 inch minimum high yellow letters, either decal or stencil.

6.8.2 A 9" X 9" adhesive label containing the following information shall be affixed on the tank wall as show in FIGURE 4:

- System voltage: **4kV, 13kV or 34kV**
- KVA value and
- PECO Catalog ID. **133-XXXXX**

These labels shall be purchased from the UTICOM Company. Labels from an alternate manufacturer will not be acceptable unless approved by PECO:

6.8.3 The bayonet or full range current limiting fusing information (See Table 2 for Operating Voltage, Amp value, and PECO Energy Company stock code number for single and dual voltage units) shall be marked inside the compartment door and oriented so as to be readable when the door is opened with a 1 inch minimum high yellow letters, either decal or stencil. The following example shall be used to stencil the bayonet fusing information:

**"USE \_\_\_\_ AMP BAYONET FUSE PECO CODE NUMBER 138-\_\_\_\_"**

6.8.4 The transformers shall be shipped with PECO Energy Company high-voltage equipment Warning/Caution/Notice and PCB labels affixed externally on the compartment door. The labels shall be located in the center of the door above the top of the sill plate as shown in FIGURE 4 of this specification.

6.8.5 The Warning/Caution/Notice label shall be in accordance with FIGURE 5 of this specification. This label will be supplied to the manufacturer upon verbal request. Contact the PECO Energy Company's Procurement Specialist to obtain a supply of labels. Two weeks advance notice is required.

6.8.6 A yellow "CAUTION" decal, with minimum 1/4" black lettering shall be affixed below or next to the sight glass and read: "**DO NOT OPERATE PRIMARY SWITCH IF FLOAT INDICATOR IS AT THE BOTTOM OF SIGHT GLASS**" (see Section 6.5).

6.8.7 A yellow "CAUTION" decal, with minimum 1/4" black lettering shall be affixed below or next to the bayonet fuses and read: "**DO NOT OPERATE BAYONET FUSES IF FLOAT INDICATOR IS AT THE BOTTOM OF SIGHT GLASS**".

6.8.8 Lower size letters on smaller KVA units may be acceptable upon PECO's approval of drawings that show the stenciling and/or labels.

6.8.9 All markings (decal or stencil) and labels shall be weather resistant.

## **7.0 Design Approval and Test Data**

### **7.1 Design Approval**

7.1.1 The following drawings shall be submitted to PECO Energy Company for review and approval.

7.1.1.1 An outline drawing with a detailed bill of material (BOM). The BOM shall list all part numbers including manufacturer. The drawing shall show critical tank characteristics including but not limited to the following: tank material, size, dimensions, hanger bracket type, weight, accessories (e.g. loadbreak switch), labels, coating system, and terminal markings.

7.1.1.2 Drawings for each of the following transformer accessories:

7.1.1.2.1 High-voltage bushings

7.1.1.2.2 Low-voltage bushings and terminals

7.1.1.2.3 Neutral terminals

7.1.1.2.4 High-voltage gang operated load break switch

7.1.1.2.5 Bayonet fuse assembly

7.1.1.2.6 Pressure Relief Valve

7.1.1.2.7 Surge Arrester

7.1.1.2.8 Sight Glass

7.1.1.2.9 Drain Valve

7.1.1.3 A nameplate drawing that contains the information listed in Section 6.7.

7.1.2 All drawings, except for the part drawings, shall reference PECO Energy Company's specification number and Catalog Id. number.

7.1.3 Revisions to any drawing previously submitted and approved shall be re-submitted to PECO Energy Company for review and approval.

### **7.2 Test Data**

7.2.1 The manufacturer shall furnish, without cost to the PECO Energy Company, one certified copy of factory test data set for each transformer shipped. The data requirements shall include the standard, extended and calculated data sets listed in sections 4.2, 4.3 and 4.4 of IEEE Standard C57.12.37 - 2015 and transmitted to PECO Energy Company electronically (Microsoft EXCEL or compatible format) in accordance with the same standard. The price of the unit shall also be included in the standard data set.

7.2.2 Upon request, the manufacturer shall furnish, without cost to the PECO Energy Company, one certified copy of all factory design data. Design data may include, but not limited to: electrical tests including ANSI/IEEE dielectric tests, mechanical tests (pressure relief tests, etc.), and coating/corrosion minimizing tests.

## **8.0 Compliance Requirements**

- 8.1** The manufacturer shall comply with all the requirements of this specification and the Request for Proposal (RFP) covered by the Exelon Energy Delivery Purchase Order.
- 8.2** Any exceptions or deviations from either this specification or the RFP requirements shall be submitted in writing by the manufacturer to PECO Energy Company for review and approval.
- 8.3** Revision to drawings previously approved by PECO Energy Company must be re-submitted to PECO Energy Company for review and approval.

## **9.0 Packing and Shipping Requirements**

- 9.1** Transformers shall be firmly secured to wooden pallets for shipping. Pallets shall be made of wood with sufficient thickness as not to break under the weight of the transformer during shipment and storage, sized such that no part of the transformer extends beyond the vertical extension of the pallet's edges, and designed so that they can be picked up by a forklift truck. Transformers shall be side-loaded on open-top trucks for shipping.

**TABLE 1**

SYSTEM VOLTAGE CLASS	DESCRIPTION	75KVA	150KVA	300KVA	500KVA	750KVA	1000KVA	1500KVA	2500KVA
4kV	HV: 4160GRDY/2400 LV: 208Y/120	133-73000	133-73001	133-73002	133-73003	133-73004	-	-	-
4kV	HV: 4160GRDY/2400 LV: 480Y/277	-	133-73006	133-73007	133-73008	133-73009	133-73010	-	-
4kV DST	HV: 4160Y LV: 240 Delta w/120 MT	133-73011	133-73012	133-73013	133-73014	-	-	-	-
13kV	HV: 13200GRDY/7620 LV: 208Y/120	133-71491	133-71492	133-71494	133-71495	133-71496	133-72206	-	-
13kV	HV: 13200GRDY/7620 LV: 480Y/277	-	133-72195	133-72196	133-72197	133-72198	133-73024	133-73025	-
13kV DST	HV: 13200Y LV: 240 Delta w/120 MT	133-71497	133-71498	133-71499	133-73016	-	-	-	-
34kV	HV: 33260GRDY/19200 LV: 208Y/120	133-71478	133-71479	133-71480	133-71481	133-71482	-	-	-
34kV	HV: 33260GRDY/19200 LV: 480Y/277	-	133-72200	133-71486	133-71487	133-71488	133-71489	133-71490	-
34kV	HV: 33260GRDY/19200 LV: 240Y/139	-	133-72295	133-72296	133-72297	133-72298	-	-	-
13kV STEP	HV: 13200GRDY/7620 LV: 4160Y/2400	-	-	133-72225	133-72226	133-72227	133-72228	-	-
34kV STEP	HV: 33260GRDY/19200 LV: 4160Y/2400	-	-	-	133-72202	133-72244	133-72203	-	-
34kV STEP	HV: 33260GRDY/19200 LV: 13200Y/7620	-	-	-	-	-	-	133-72294	133-72293

**DST**- Unit connected with a Primary WYE and a Secondary DELTA  
**STEP** - STEP Down or Interposing Transformer

**TABLE 2**  
**IMPEDANCE AND FUSING REQUIREMENTS**

SYSTEM VOLTAGE CLASS	PECO Transformer Code Number	KVA Size	Min. IZ (%)	Operating Voltage	Fuse Size (Amp)	PECO Fuse Code No.	Bayonet Fuse Cooper Type	Partial or Full Range Current Limiting Fuse. Cooper Type Unless Specified
4kV	133-73000	75	2.0	4kV	25	138-29890	4000358C10	CBUC08100C100
	133-73001	150	2.0	4kV	50	138-29891	4000358C12	CBUC08165D100
	133-73002	300	3.0	4kV	100	138-29921	4000353C16	CBUC08165D100
	133-73003	500	4.0	4kV	140	138-29905	4000353C17	CBUC08150D100
	133-73004	750	5.5	4kV	125	138-76096	4038361C05CB	CBUC08250D100
	133-73006	150	2.0	4kV	50	138-29891	4000358C12	CBUC08165D100
	133-73007	300	3.0	4kV	100	138-29921	4000353C16	CBUC08165D100
	133-73008	500	4.0	4kV	140	138-29905	4000353C17	CBUC08150D100
	133-73009	750	5.5	4kV	125	138-76096	4038361C05CB	CBUC08250D100
4kV DTS	133-73010	1000	5.5	4kV	-	-	(*)	Parallel Hi-Tech HTSS232165
	133-73011	75	2.0	4kV	25	138-29890	4000358C10	CBUC08125C100
	133-73012	150	2.0	4kV	50	138-29891	4000358C12	CBUC08150D100
	133-73013	300	3.0	4kV	100	138-29921	4000353C16	CBUC08165D100
13kV	133-71491	75	1.6	13kV	8	138-29888	4000358C05	CBUC08030C100
	133-71492	150	2.0	13kV	15	138-29889	4000358C08	CBUC08080C100
	133-71494	300	3.0	13kV	40	138-29920	4000353C12	CBUC08100C100
	133-71495	500	3.5	13kV	50	138-29891	4000358C12	CBUC08150D100
	133-71496	750	4.0	13kV	100	138-29921	4000353C16	CBUC08165D100
	133-72206	1000	5.5	13kV	140	138-29905	4000353C17	CBUC08150D100 (2)**
	133-72195	150	2.0	13kV	15	138-29889	4000358C08	CBUC08080C100
	133-72196	300	3.0	13kV	40	138-29920	4000353C12	CBUC08100C100
	133-72197	500	3.5	13kV	50	138-29891	4000358C12	CBUC08150D100
	133-72198	750	5.5	13kV	100	138-29921	4000353C16	CBUC08165D100
	133-73024	1000	5.5	13kV	140	138-29905	4000353C17	CBUC08150D100 (2)**
	133-73025	1500	5.5	13kV	140	138-29905	4000353C17	CBUC08150D100 (2)**
13kV DTS	133-71497	75	1.5	13kV	8	138-29888	4000358C05	CBUC15030C100
	133-71498	150	3.0	13kV	15	138-29889	4000358C08	CBUC15080C100
	133-71499	300	2.0	13kV	40	138-29920	4000353C12	CBUC15100C100
	133-73016	500	3.5	13kV	50	138-29891	4000358C12	CBUC15125C100
34kV	133-71478	75	1.6	34kV	3	138-29887	4000358C03	CBUC23030C100
	133-71479	150	2.0	34kV	8	138-29888	4000358C05	CBUC23030C100
	133-71480	300	3.0	34kV	15	138-29889	4000358C08	CBUC23080C100
	133-71481	500	3.5	34kV	25	138-29890	4000358C10	CBUC23080C100
	133-71482	750	5.5	34kV	40	138-29920	4000353C12	CBUC23080C100
	133-72200	150	2.0	34kV	8	138-29888	4000358C05	CBUC23030C100
	133-71486	300	3.0	34kV	15	138-29889	4000358C08	CBUC23080C100
	133-71487	500	3.5	34kV	25	138-29890	4000358C10	CBUC23080C100
	133-71488	750	5.5	34kV	40	138-29920	4000353C12	CBUC23080C100
	133-71489	1000	5.5	34kV	50	138-29891	4000358C12	CBUC23125D100
	133-71490	1500	5.5	34kV	65	138-29902	4000353C14	CBUC23150D100
	133-72295	150	2.0	34kV	8	138-29888	4000358C05	CBUC23030C100
	133-72296	300	3.0	34kV	15	138-29889	4000358C08	CBUC23080C100
	133-72297	500	2.0	34kV	25	138-29890	4000358C10	CBUC23080C100
133-72298	750	5.5	34kV	40	138-29920	4000353C12	CBUC23080C100	
13kV STEP	133-72225	300	1.5	13kV	40	138-29920	4000353C12	CBUC08125C100
	133-72226	500	2.0	13kV	50	138-29891	4000358C12	CBUC08165D100
	133-72227	750	4.0	13kV	100	138-29921	4000353C16	CBUC08165D100
	133-72228	1000	5.5	13kV	140	138-29905	4000353C17	CBUC08150D100 (2)**
34kV STEP	133-72202	500	3.5	34kV	25	138-29890	4000358C10	CBUC23080C100
	133-72244	750	5.5	34kV	40	138-29920	4000353C12	CBUC23080C100
	133-72203	1000	5.5	34kV	50	138-29891	4000358C12	CBUC23125D100
	133-72294	1500	5.5	34kV	65	138-29902	4000353C14	CBUC23150D100
	133-72293	2500	5.5	34kV	-	-	-	-

(\*) In-Oil Expulsion Fuse ABB 592B581G32

(\*\*) 2 in Parallel

# FIGURE 1

## THREE PHASE PADMOUNTED TRANSFORMER

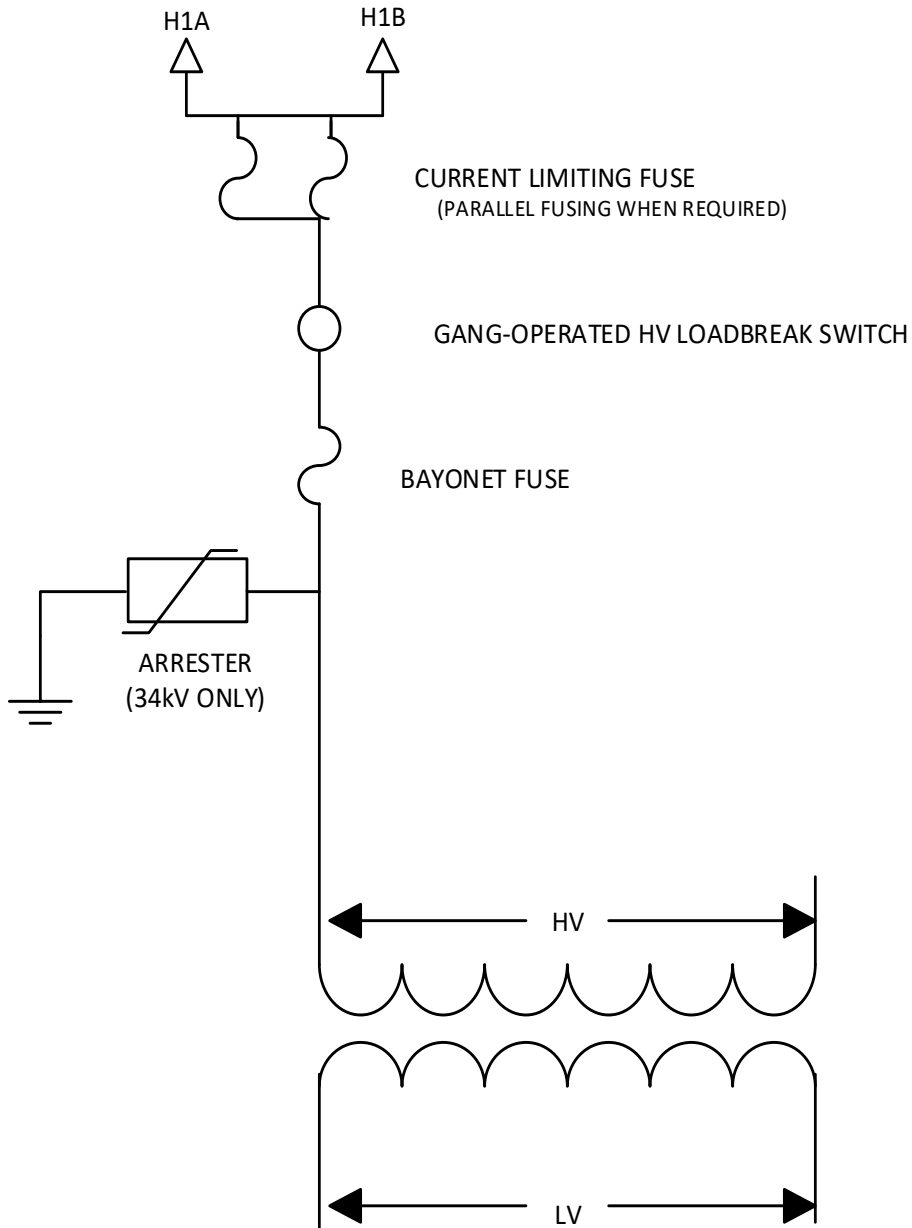

(Only one Phase is shown for Illustration Purposes Only)

# FIGURE 2

## THREE PHASE PADMOUNTED TRANSFORMER 4kV and 13kV HIGH VOLTAGE COMPARTMENT

NOTE: NOT DRAWN TO SCALE

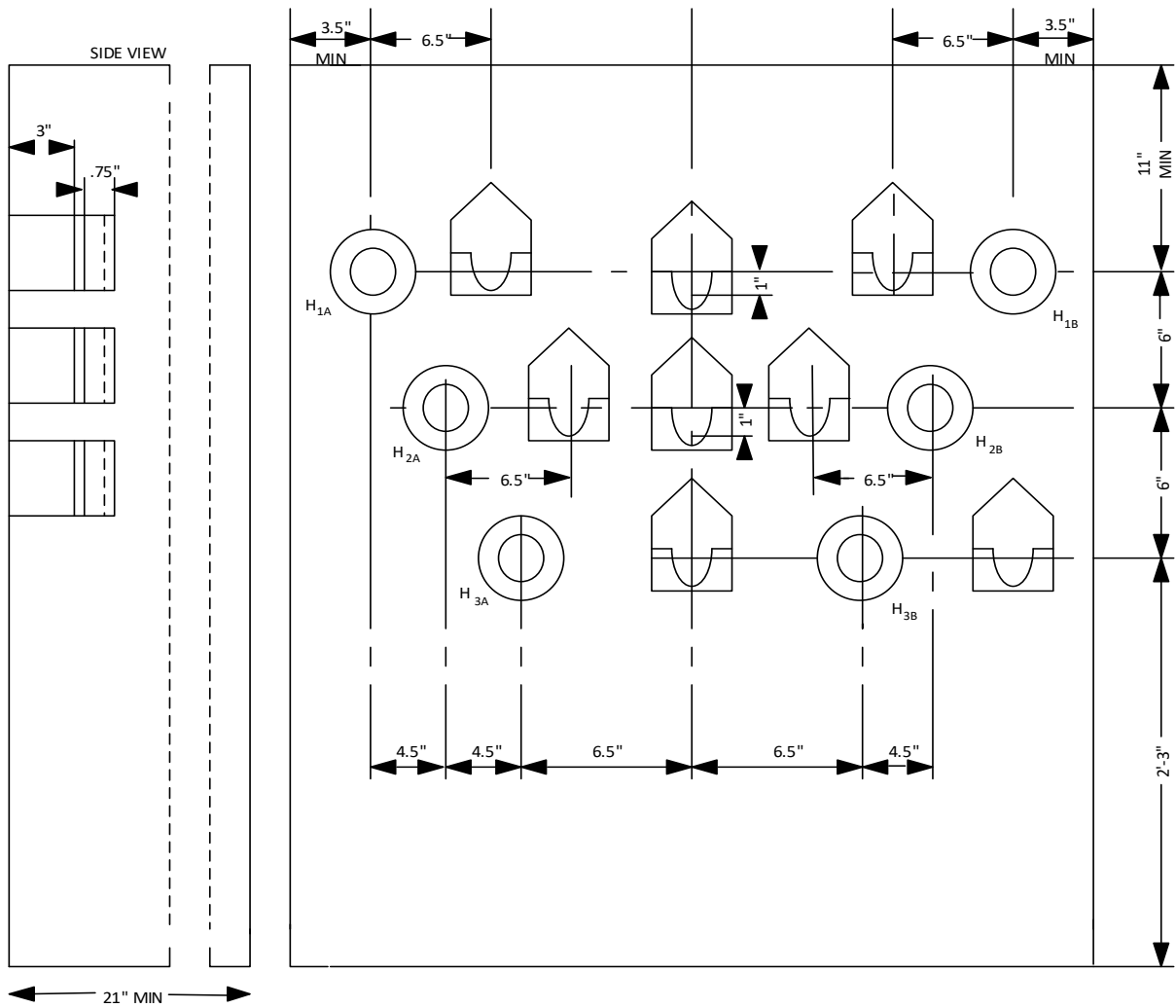

# FIGURE 3

## THREE PHASE PADMOUNTED TRANSFORMER 34KV HIGH VOLTAGE COMPARTMENT

NOTE: NOT DRAWN TO SCALE

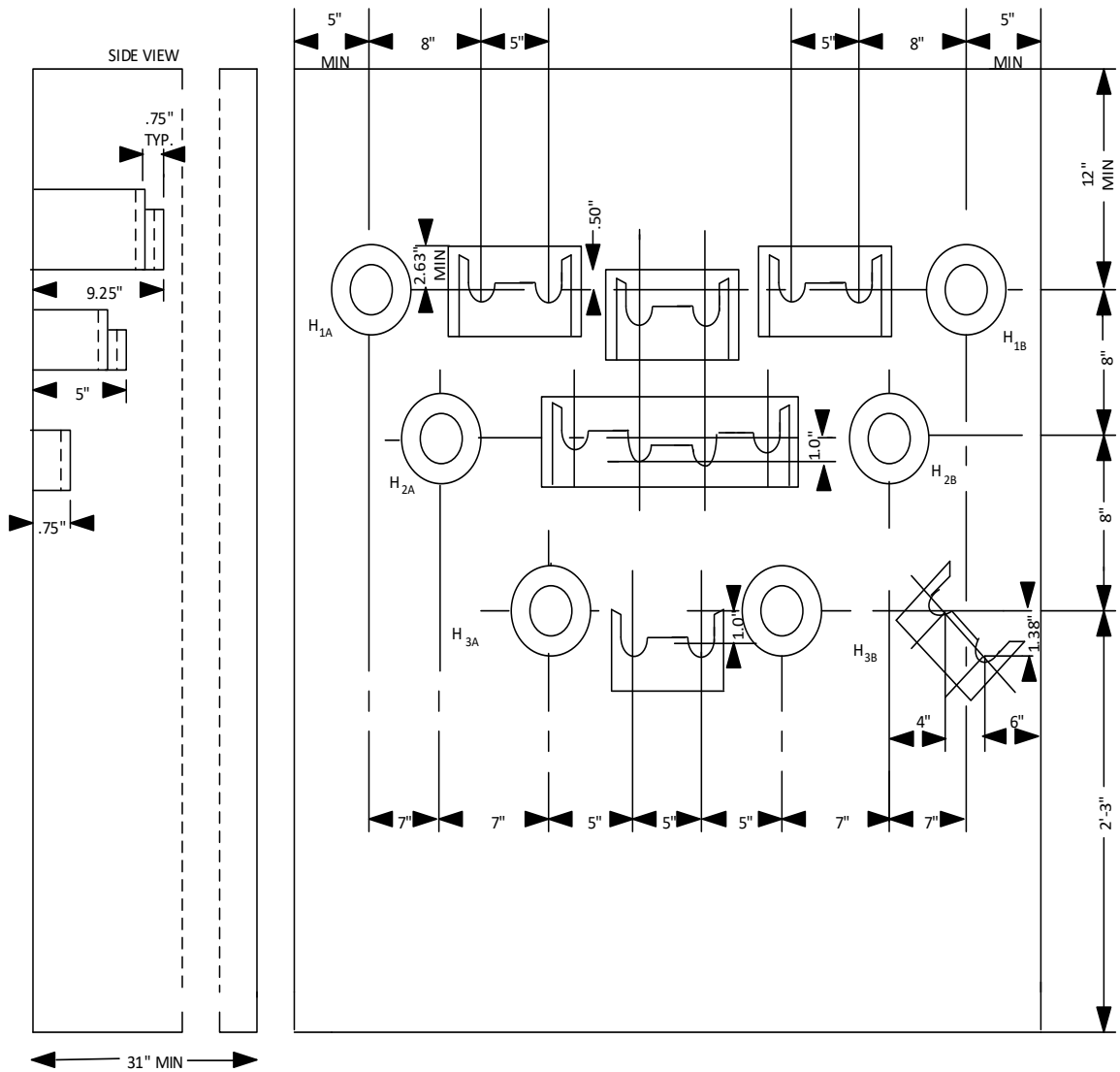

# FIGURE 4

## THREE PHASE PADMOUNTED TRANSFORMER EXTERNAL STENCILING/DECAL AND LABELING REQUIREMENTS

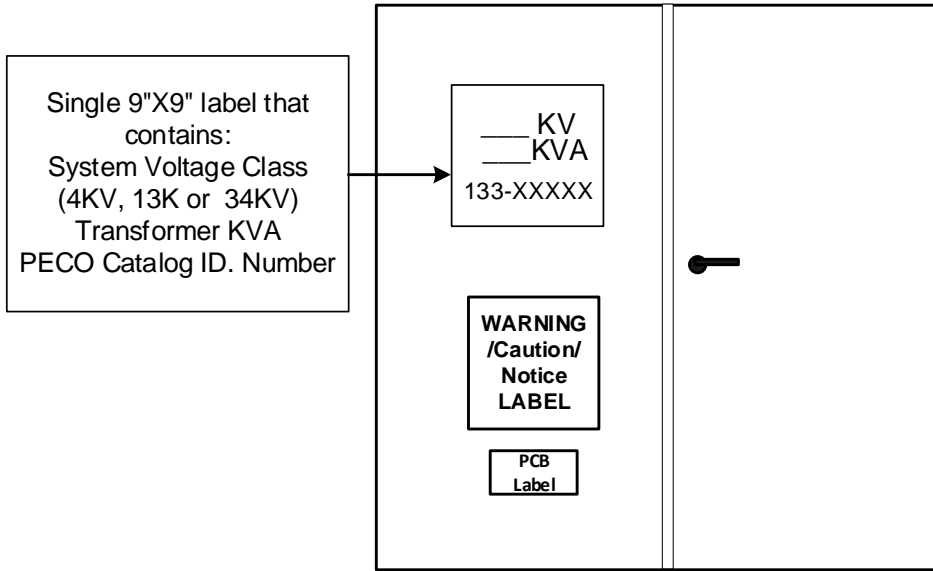

TRANSFORMER FRONT VIEW

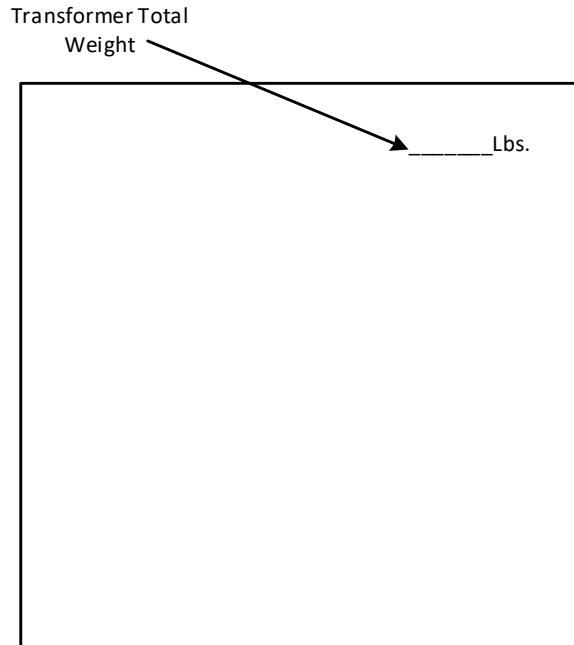

TRANSFORMER BACK VIEW

FIGURE 5

9.5"

**! WARNING**

**Hazardous voltage. KEEP OUT!**

Can shock, burn or cause death. If this enclosure is found unlocked, open or damaged, immediately call:

**PECO ENERGY COMPANY**  
1-800-494-4000



**! ¡ADVERTENCIA!**

**Alto Voltaje Adentro. NO ACERCARSE!**

Puede electrocutar, quemar o causar muerte. Si este cerco es encontrado sin trancar, abierto o dañado, llame inmediatamente a:

**PECO ENERGY COMPANY**  
1-800-494-4000



**! WARNING**

Underground power cables are located in this area.



**BEFORE YOU DIG-DRILL-BLAST**  
PA ONE CALL SYSTEM  
1-800-242-1776  
PA LAW REQUIRES ADVANCED NOTIFICATION



Can shock, burn or cause death.

**! ¡ADVERTENCIA!**

Cables subterráneos de alto voltaje existen en esta area.



**ANTES DE QUE USTED EXCAVE - PERFORE - EXPLOTE**  
LLAME AL SISTEMA DE LLAMADAS PA ONE  
1-800-242-1776  
LA LEY DEL PA REQUIERE LA NOTIFICACIÓN AVANZADA



Puede electrocutar, quemar o causar muerte.

11.5"

**NOTICE**

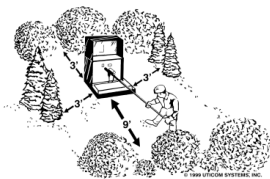

We need room to work safely on this device. Please keep shrubs and structures 9 feet away from the side with doors and 3 feet from other sides.

Obstructions may be damaged or removed during service restoration or maintenance.

**AVISO**

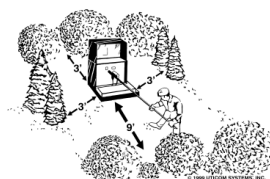

Necesitamos espacio suficiente para trabajar sin riesgos en este aparato. Por favor mantenga arbustos y estructuras a 9 pies de las puertas y 3 pies de los lados.

Estas obstrucciones podrán ser dañadas o removidas durante la restauración del servicio o mantenimiento.

▲ US1 U139-84563-C

# **EXHIBIT 5**

BARTHOLOMEW LAWRENCE

446 SHURS LANE

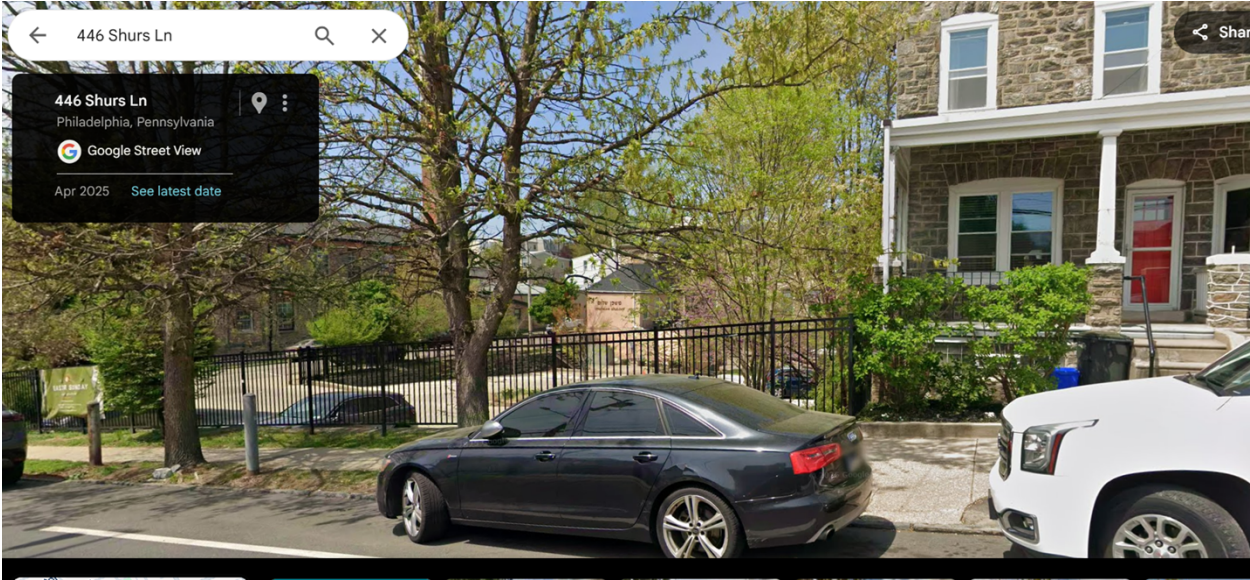
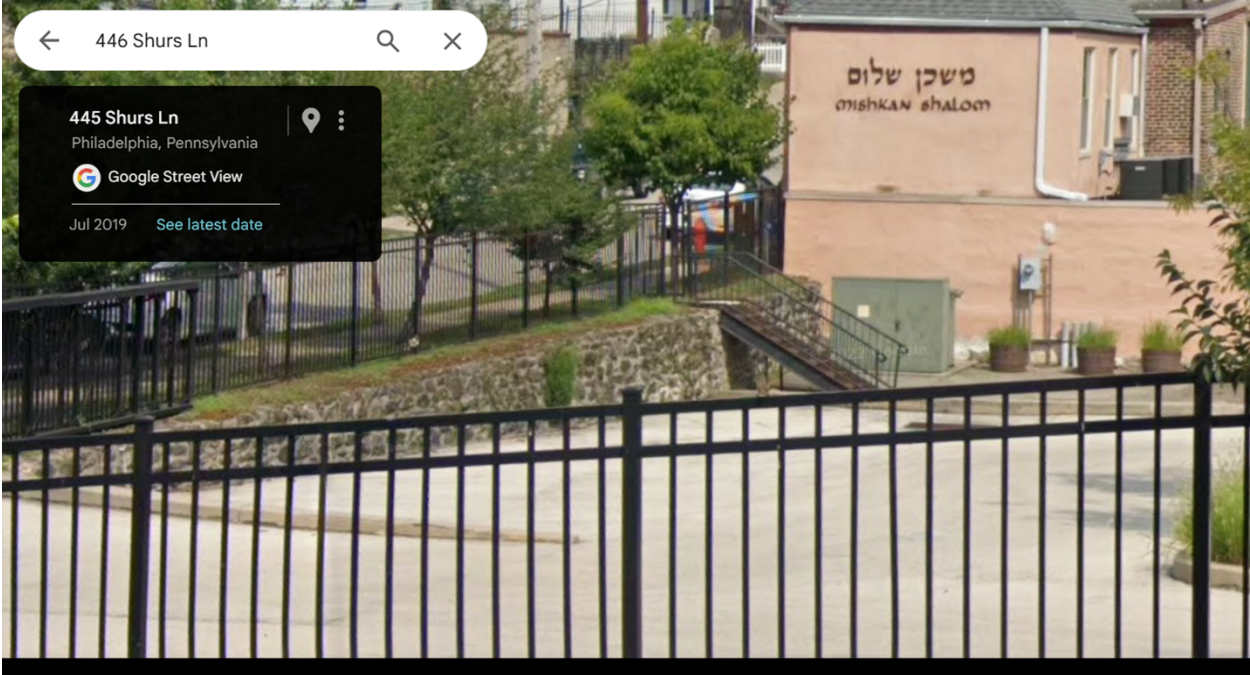

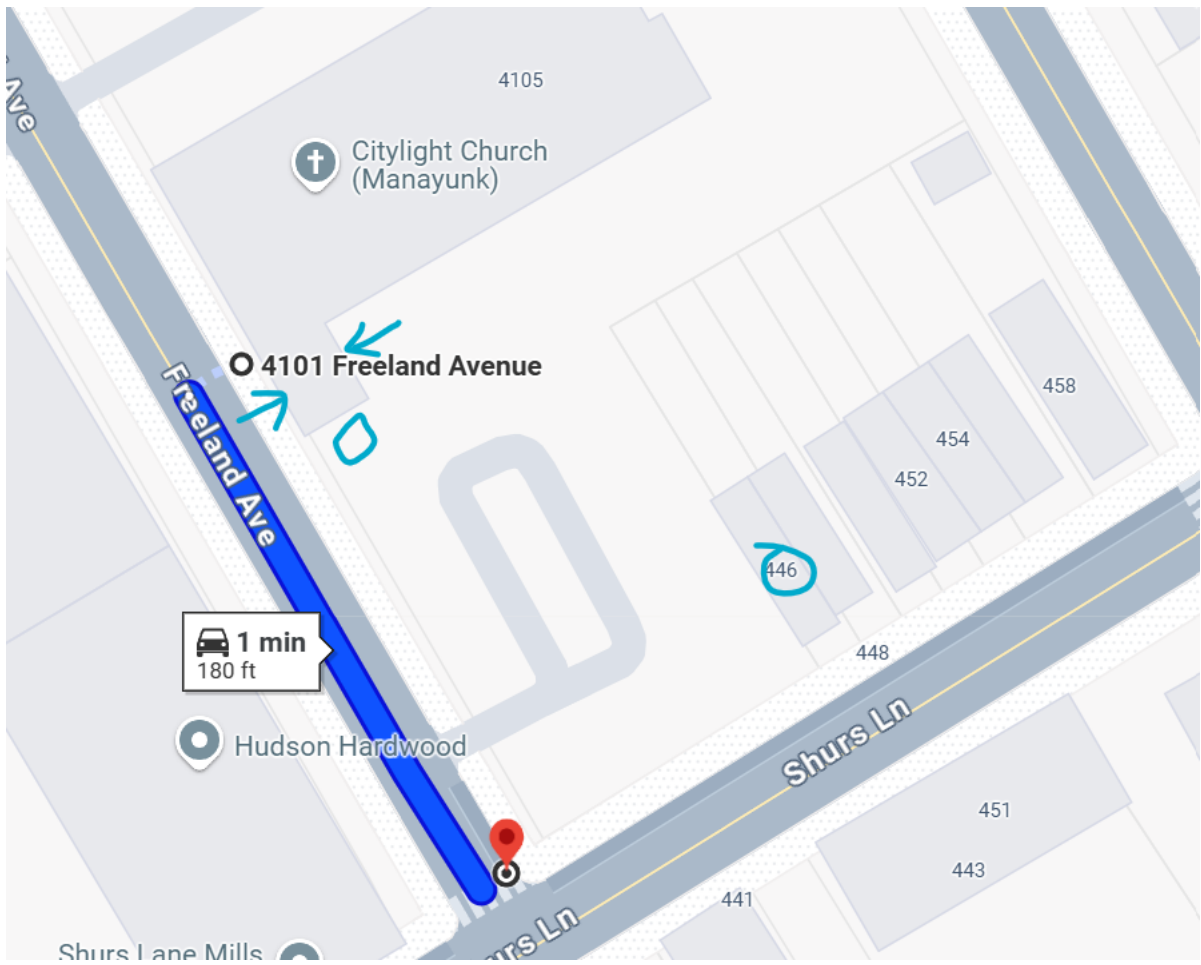
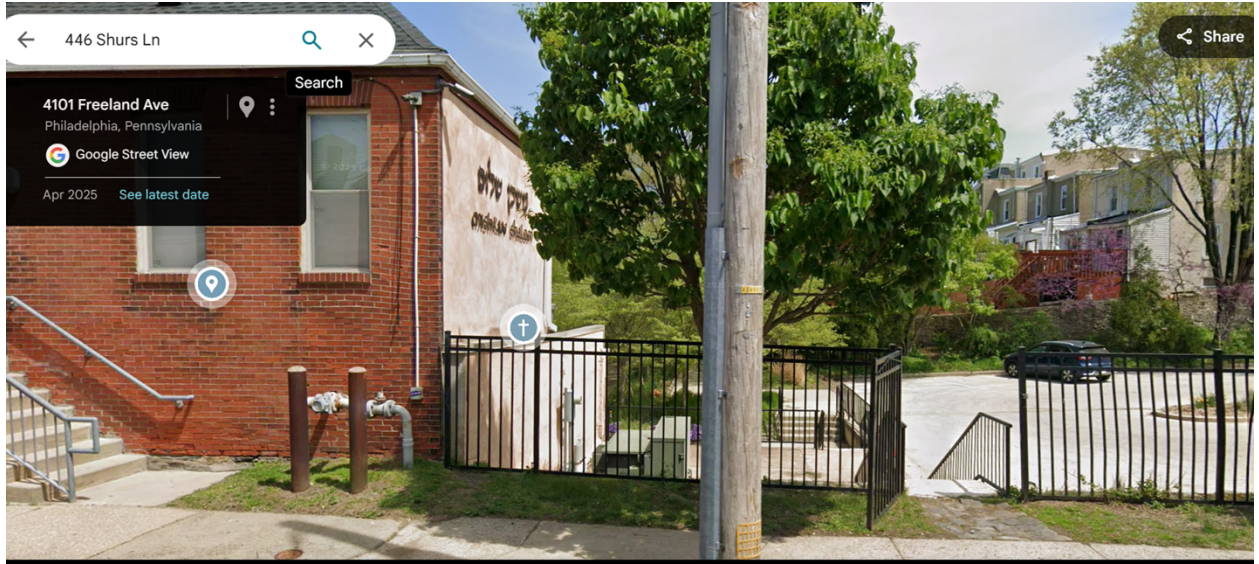

Hearing 9/30/25 @ 1PM

# Noisy PECO Transformer location to 446 Shurs Lane

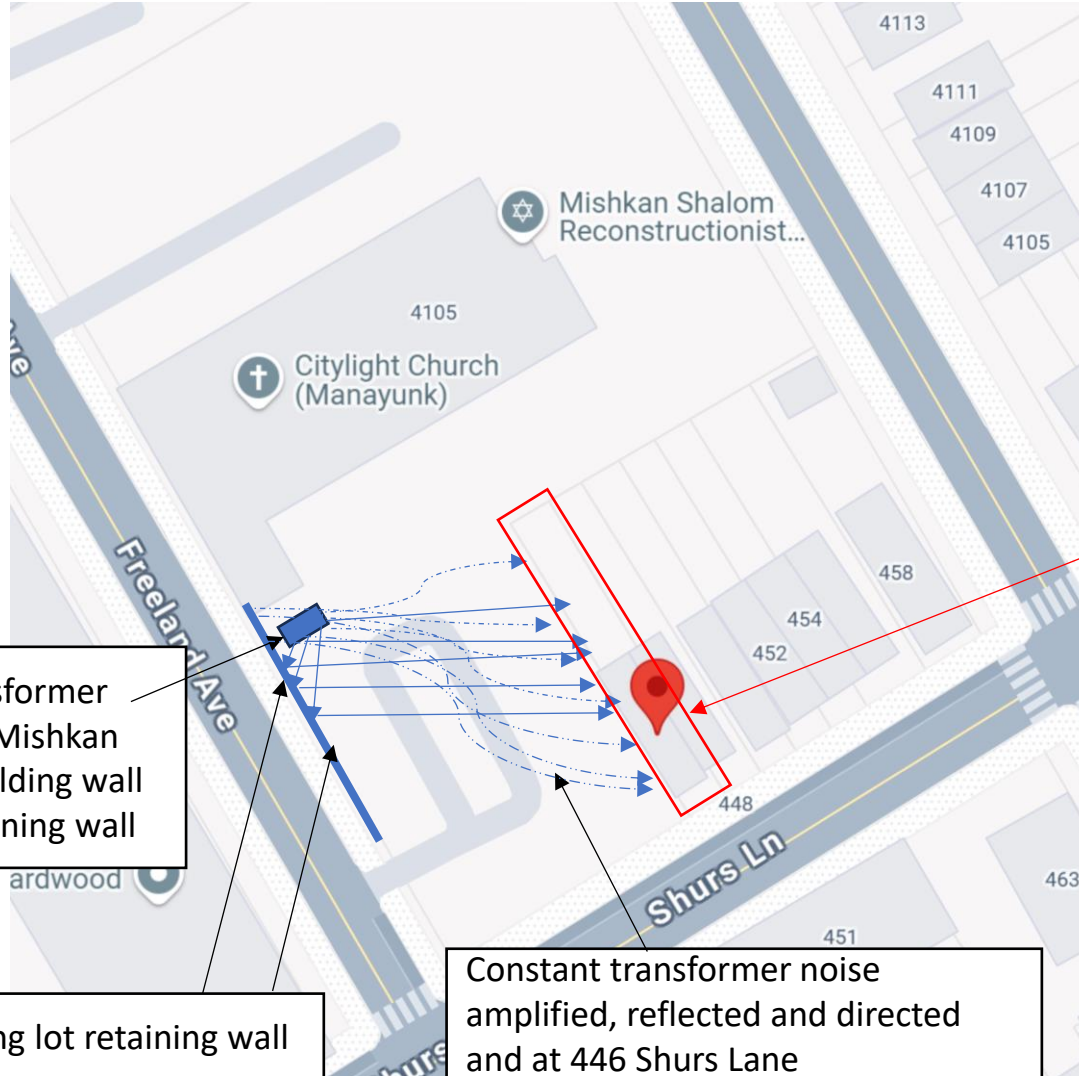

PECO PAD mount transformer mounted at corner of Mishkan Shalom Synagogue building wall and 4' parking lot retaining wall

4-foot parking lot retaining wall

Constant transformer noise amplified, reflected and directed and at 446 Shurs Lane

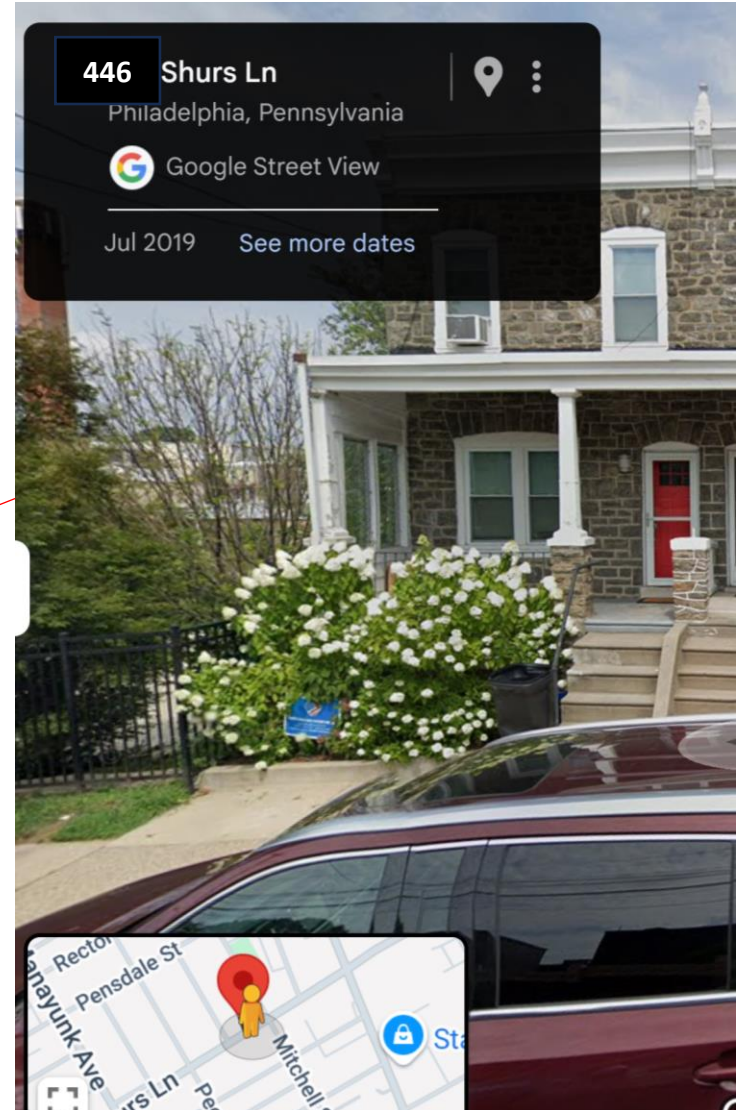

# Noisy PECO Transformer location to 446 Shurs Lane

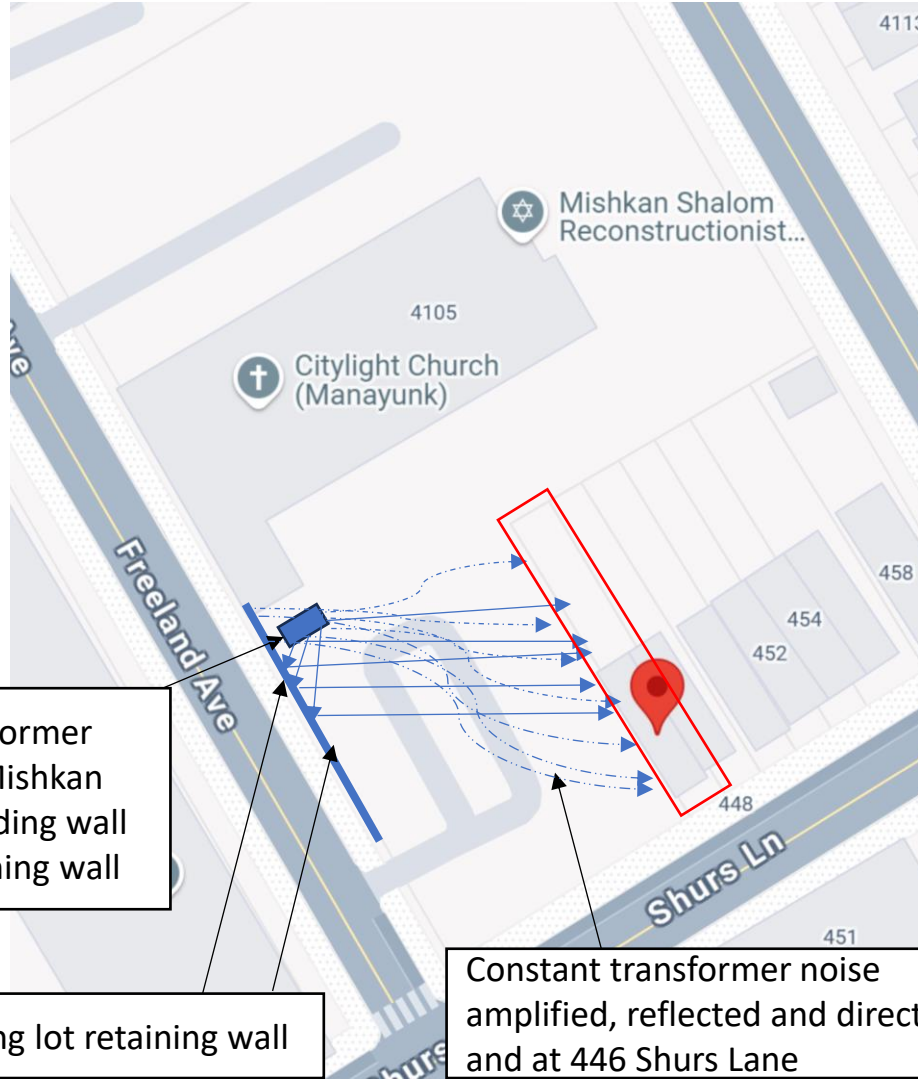

PECO PAD mount transformer mounted at corner of Mishkan Shalom Synagogue building wall and 4' parking lot retaining wall

4-foot parking lot retaining wall

Constant transformer noise amplified, reflected and directed and at 446 Shurs Lane



Our property at 446 runs alongside the synagogue's entire parking lot and walkways

# Noisy PECO Transformer location to 446 Shurs Lane

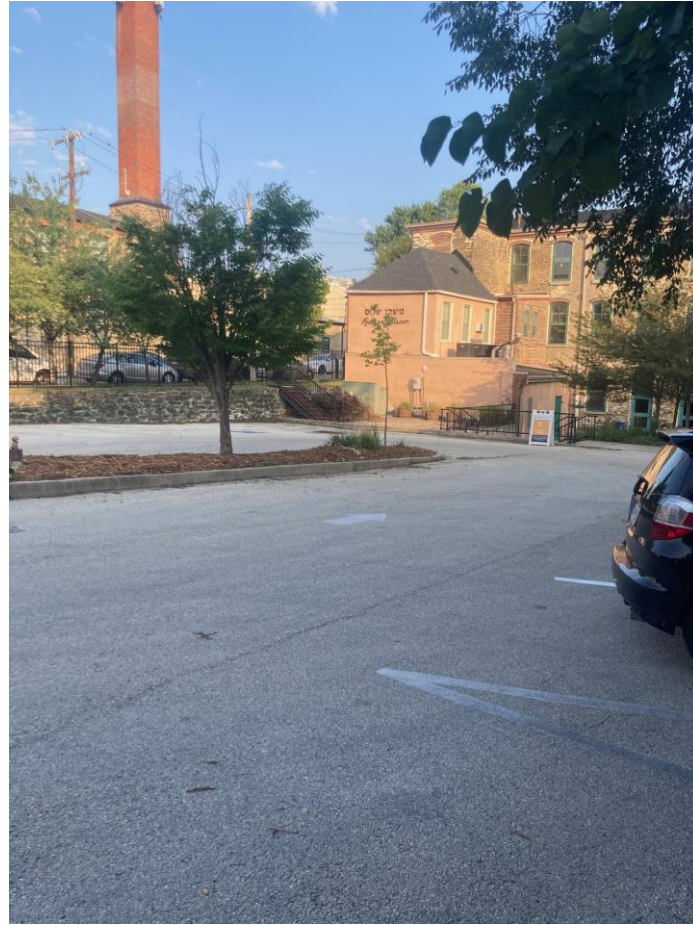

Our property at 446 runs alongside the synagogue's entire parking lot and walkways

# Noisy PECO Transformer location to 446 Shurs Lane



Our property at 446 runs alongside the synagogue's entire parking lot and walkways

# Noisy PECO Transformer location to 446 Shurs Lane



Our property at 446 runs alongside the synagogue's entire parking lot and walkways

# Pad Mount Transformers Should Not Be Placed in Corners

- PECO & Mishkan Shalom ignored accepted Industry practices and installed their Transformer in high walled corner creating noise issues
- High walled corners around transformer act as acoustic reflectors amplifying and directing all noise at 446 Shurs Lane property.
- Placement in corner limits noise dissipation in other directions increasing transformer noise levels directed at 446 Shurs Lane.
- Tight corner placement creates reverberation and standing sound waves directed at 446 Shurs lane property.



## What google says about placing transformers in corners

While a corner installation might seem convenient, it's generally not recommended to install a utility pad transformer in a corner, as it can lead to increased noise and sound transmission to surrounding structures.

Here's a more detailed explanation:

**Sound Transmission:**  
Corners, walls, and ceilings can amplify and reflect sound, making a transformer installed in a corner potentially louder and more disruptive.

**Clearance and Safety:**  
While the specific requirements can vary depending on the transformer size and local codes, it's generally best to avoid placing transformers directly against walls or other structures to ensure adequate clearance for maintenance and safety.

**Alternative Solutions:**  
If a corner installation is unavoidable, consider using sound-absorbing materials on the walls

## What Eaton, the maker of this transformer, says about placing their transformers in corners like this



**Sound dampening**  
To minimize sound transmission to surrounding structures, it is recommended that the transformer be installed away from corners, walls, or ceilings. For installations that must be near a corner, sound absorbing materials can be used on the walls and ceiling.  
The use of flexible conduit to make the connections to the transformers is also recommended to reduce vibration and sound transmission.



Vibration isolation options

eaton.com

# Eaton's Transformer Catalog – “Transformers Should Not Be Placed in Corners”



PECO & Mishkan Shalom installed their transformer in high walled corner creating noise issues

- Installed against Transformer Manufacturer's written installation instructions
- Installed against industry's accepted best practices
- Also, PECO's transformer may violate NEMA ST-200, Maximum Audio Sound Levels for 600V Class Transformers



**What Eaton, the maker of this transformer, says about placing their transformers in corners like this**

**Dry-Type Distribution Transformers**  
**General Purpose**  
 General Purpose Ventilated Transformers

Design Guide DG009001EN  
 Effective February 2025  
**19.1-4**

**Enclosures**

The transformer enclosure is made of heavy-gauge steel and is finished using a continuous process of degreasing, cleaning and phosphatizing, followed by electrostatic deposition of a thermo-setting polyester powder coating and subsequent baking. The coating color is ANSI 61 and is UL recognized for outdoor use. In compliance with NEMA ST-20, Eaton's ventilated transformers are designed such that the maximum temperature on the top of the enclosure does not exceed 50 °C rise above the ambient temperature.

For ventilated transformers, the enclosure construction is ventilated, drip-proof, NEMA 2, with lifting provisions.

All ventilation openings are protected against falling dirt. Proper installation of weathershields on ventilated transformers makes the enclosure NEMA 3R rated and suitable for outdoor use.

To ensure proper ventilation and cooling of the transformer, follow manufacturer's recommended clearances around ventilation openings.

**Installation Clearances**

Eaton's transformers should be installed with a minimum clearance around the transformer enclosure to prevent accidental contact with flammable or combustible materials. The minimum required clearance from the back panel varies by transformer design. Many small kVA ventilated transformers (150 kVA and smaller) require just 2 inches of clearance, while larger kVA transformers require 6-inch clearance or more. Minimum installation clearances are stated on the nameplate of all transformers.

The NEC requires a minimum of 36 inches clearance in front of the transformer for safe installation and maintenance. Care should be taken to avoid restricting the airflow through the bottom of the transformer.

Transformers should be located in areas not accessible to the public.

**Sound Levels**

All transformers emit some audible sound due mainly to the vibration generated in their core by alternating flux. NEMA ST-20 defines the maximum average sound levels for transformers.

All Eaton ventilated transformers are designed to have audible sound levels lower than those required by NEMA ST-20 (2014). However, consideration should be given to the specific location of a transformer and its installation to minimize the potential for sound transmission to surrounding structures and sound reflection. Installation and ambient conditions at a specific location can result in field-measured audible sound levels as much as 15 dBA greater than those levels measured in a sound-proof chamber. The following installation methods should be considered:

1. If possible, mount the transformer away from corners of walls or ceilings. For installations that must be near a corner, use sound-absorbing materials on the walls and ceiling if necessary to eliminate reflection.

2. Provide a solid foundation for mounting the transformer and use vibration dampening mounts if not already provided in the transformer. Eaton's ventilated transformers contain a built-in vibration dampening system to minimize and isolate sound transmission. However, supplemental vibration dampening mounts installed between the floor and the transformer may provide additional sound dampening.

3. Make electrical connections to the transformer using flexible conduit.

4. Locate the transformer in an area where audible sound is not offensive to building inhabitants.

5. If a transformer is going to be installed in a location where the audible sound could be objectionable, consider installing a transformer specifically designed to have reduced sound levels. Eaton offers many transformers with a sound reduction up to 5 dB below NEMA ST-20 limits.

**Table 19.1-1. NEMA ST-20 (2014) Maximum Audible Sound Levels for 600 V Class Transformers (dBA)**

Equivalent Winding kVA Range	Average Sound Level, Decibels			
	Self-Cooled Ventilated			Self-Cooled Sealed
	A	B	C	
	K Factor = 1 K Factor = 4 K Factor = 9	K Factor = 13 K Factor = 20	Forced Air When Fans Running	
3.00 and below	40	40	67	45
3.01 to 9.00	40	40	67	45
9.01 to 15.00	45	45	67	50
15.01 to 30.00	45	45	67	50
30.01 to 50.00	45	48	67	50
50.01 to 75.00	50	53	67	55
75.01 to 112.50	50	53	67	55
112.51 to 150.00	50	53	67	55
150.01 to 225.00	55	58	67	57
225.01 to 300.00	55	58	67	57
300.01 to 500.00	60	63	67	59
500.01 to 700.00	62	65	67	61
700.01 to 1000.00	64	67	67	63
Greater than 1000	Consult factory			

**Note:** Consult factory for nonlinear requirements exceeding a K-factor rating of 20. When the fans are not running, columns A and B apply. Sound levels are measured using the A-weighted scale (dBA).

# Eaton's Installation Instructions—“Transformers Should Not Be Placed in Corners”



PECO & Mishkan Shalom installed their transformer in high walled corner creating noise issues

- Installed against Transformer Manufacturer's written installation instructions
- Installed against industry's accepted best practices
- Also, PECO's transformer may violate NEMA ST-200, Maximum Audio Sound Levels for 600V Class Transformers



## What Eaton, the maker of this transformer, says about placing their transformers in corners like this

Page 4 of 9      Pag. 4 de 9      I.L. PG24836G-591H

**4. STORAGE PRIOR TO ENERGIZATION**

Store Low-Voltage Dry-Type Distribution Transformers in their original shipping cartons indoors in a clean, dry, temperature stable environment.

**5. LOCATION AND MOUNTING**

All dry-type transformers:

- Locate the transformer in an area where the transformer is easily accessible and serviceable by qualified personnel.
- Install the transformer in accordance with the requirements of Article 450 of the National Electrical Code and other appropriate local codes.
- Install the transformer in a protected electrical circuit. Do not subject the transformer to voltage surges unless it is properly protected.
- Transformers are not tamper proof and should be installed in secured locations away from all unauthorized personnel.
- Locate transformer in a well-ventilated area free from excessive moisture, dust, dirt, or explosive/corrosive gases or vapors.
- Locate the transformer at least the minimum distance marked on the nameplate to assure proper air circulation. Avoid any obstruction to the bottom and top panel ventilation openings.
- Install transformer on a surface strong enough to support the weight of the transformer.
- Install ventilated transformers in an upright position only.
- Encapsulated transformers for indoor use may be mounted in any position. To maintain their Type 3R, Type 12, Type 4, or Type 4X enclosure rating, the transformer must be installed in an upright position with the top point upward.

Wall mount installation:

- For wall mounted ventilated transformers see Instruction Leaflet IL00902EN (Wall-mounting bracket kits WMB04 and WMB05 assembly instructions).
- WMB04 maximum weight capacity 1400 Lb.
- WMB05 maximum weight capacity 810 Lb.
- Do not install wall-mounted transformers over flammable materials, and do not store flammable materials under a wall-mounted transformer

**6. HOW TO REDUCE SOUND TRANSMISSION**

All transformers produce sound due to the vibration generated in its core by alternating flux. NEMA ST-200 defines the sound levels for dry-type distribution transformers.

All general purpose dry-type distribution transformers are designed to meet NEMA ST-200 established sound levels. However, to minimize the potential for sound transmission to surrounding structures and sound reflection, follow these instructions:

1. Mount the transformer away from corners, walls or ceilings. For installations which must be near a corner, use

Effective: February 2024

Page 5 of 9      Pag. 5 de 9      I.L. PG24836G-591H

sound absorbing materials on the adjacent walls and ceiling.

2. Use flexible conduit to make the connections to the transformers.
3. Locate the transformers as far away as possible from areas where noise is of concern.
4. Install the transformer over vibration isolators; for better results use Eaton B-Line's vibration isolation products.

**7. CONNECTING CABLES TO TRANSFORMER TERMINATIONS.**

Any standard cable of the conductor size specified in NEC Section 310 can be used. Recommended external cable should be rated 90°C and sized at 75% ampacity for encapsulated transformers and sized at 75°C for ventilated. Connectors should be selected on the basis of the type of cable and cable size used to wire the specific transformer, proper torque should be applied based on the connector's manufacturer recommendations.

- Remove access panels to access the wiring compartment.
- Top entry of cable should be avoided.
- Clean all electrical joints.
- Connect primary wiring first to correct terminal as shown on the transformer nameplate.

Transformers labeled as "Bi-directional" are suitable for reverse-feeding (back-feeding). Transformers are designed to have the incoming cables connected to the primary terminals. Transformers marked as bi-directional are suited to have the incoming cables connected to the secondary terminals. When the secondary connection is a Y (208Y/120 for example), the neutral terminal (X0 or H0) should not be connected. If the secondary is a delta connection with a center tap (aka lighting tap or convenience tap), the center tap (normally X4) cannot be connected.

When reverse-feeding a transformer the circuit breakers and fuses should be the time-delay type.

Make sure to follow NEC 250 system grounding.

Reverse-feeding a transformer may result in higher than normal inrush currents.

Reverse-feeding a transformer may cause nuisance tripping of overcurrent protective devices.

**WARNING**

Effective: Febrero 2024

una esquina, use materiales que absorban el sonido en paredes adyacentes y techo.

2. Use conducto flexible para hacer las conexiones al transformador.
3. Instale el transformador lo más alejado posible de áreas donde el ruido sea motivo de preocupación.
4. Utilice aisladores de vibración en la instalación del transformador, para mejores resultados use aisladores de vibración Eaton B-Line.

**7. CONEXION DE CABLES A LAS TERMINALES DEL TRANSFORMADOR**

Cualquier conductor estándar del calibre especificado por NEC sección 310 puede ser usado. El cable recomendado debe de estar clasificado para 90°C calculado al 75% de ampacidad en transformadores encapsulados, y calculado para 75°C en ventilados. Los conectores deberán seleccionarse específicamente de acuerdo al tipo y al calibre del conductor utilizado en la conexión al transformador, el torque correcto deberá ser aplicado de acuerdo a las recomendaciones del fabricante del conector.

- Remueva los paneles de acceso al compartimiento de alambrado.
- Evite el acceso de cable por la parte superior del gabinete.
- Limpie todas las uniones eléctricas.
- Conecte el devanado primario a la terminal correcta según se muestre en la placa de datos.

Transformadores etiquetados como "Bidireccional" pueden ser alimentados en reversa (back-feeding). Los transformadores están diseñados para conectar los cables de alimentación a las terminales del primario. Los transformadores marcados como bidireccional pueden recibir cables de alimentación a las terminales del secundario. Cuando la conexión del secundario está en estrella (por ejemplo 208Y/120), La terminal neutral (X0 o H0) no debe ser conectada. Si el secundario es una configuración delta con derivación central (derivación de alambrado), la derivación central (normalmente X4) no puede ser conectada.

Cuando se alimente un transformador en reversa, las protecciones deben de ser con retardo.

Siga NEC 250 para el Sistema de tierra física.

Alimentar en reversa un transformador puede resultar en corrientes de arranque mayores a lo normal.

Alimentar en reversa un transformador puede causar falsos disparos de las protecciones.

**ADVERTENCIA**

Effective: Febrero 2024

# PECO Transformer May Emit Sound that Exceeds NEMA ST-20

PECO & Mishkan Shalom installed their transformer in high walled corner creating noise issues

- Installed against Transformer Manufacturer's written installation instructions
- Installed against industry's accepted best practices
- Also, PECO's transformer may exceed NEMA ST-200, **Maximum Audio Sound Levels for 600V Class Transformers**
- **Want to see PECO testing showing sound transmission of this transformer compared to NEMA ST-20 before install**
- **Want to see PECO's sound site survey from when transformer was installed in 2019**

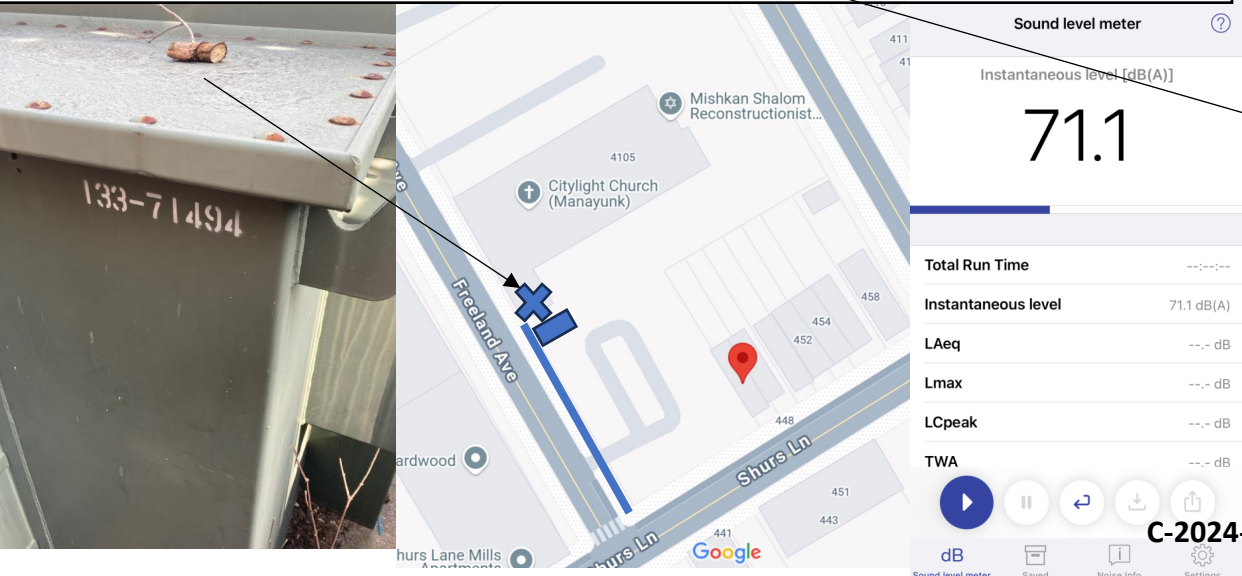

Table 19.1-1. NEMA ST-20 (2014) Maximum Audible Sound Levels for 600 V Class Transformers (dBA)

Equivalent Winding kVA Range	Average Sound Level, Decibels			
	Self-Cooled Ventilated			Self-Cooled Sealed
	A	B	C	D
	K Factor = 1 K Factor = 4 K Factor = 9	K Factor = 13 K Factor = 20	Forced Air When Fans Running	
3.00 and below	40	40	67	45
3.01 to 9.00	40	40	67	45
9.01 to 15.00	45	45	67	50
15.01 to 30.00	45	45	67	50
30.01 to 50.00	45	48	67	50
50.01 to 75.00	50	53	67	55
75.01 to 112.50	50	53	67	55
112.51 to 150.00	50	53	67	55
150.01 to 225.00	55	58	67	57
225.01 to 300.00	55	58	67	57
300.01 to 500.00	60	63	67	59
500.01 to 700.00	62	65	67	61
700.01 to 1000.00	64	67	67	63
Greater than 1000	Consult factory			

**Note:** Consult factory for nonlinear requirements exceeding a K-factor rating of 20. When the fans are not running, columns A and B apply. Sound levels are measured using the A-weighted scale (dBA).

71.1 db. behind transformer in corner between the synagogue's wall and the retaining wall. This is 13 dB to 21 dB above NEMA-ST



C-2024-3050908

# Sound Level Readings - Mishkan Shalom's Parking Lot

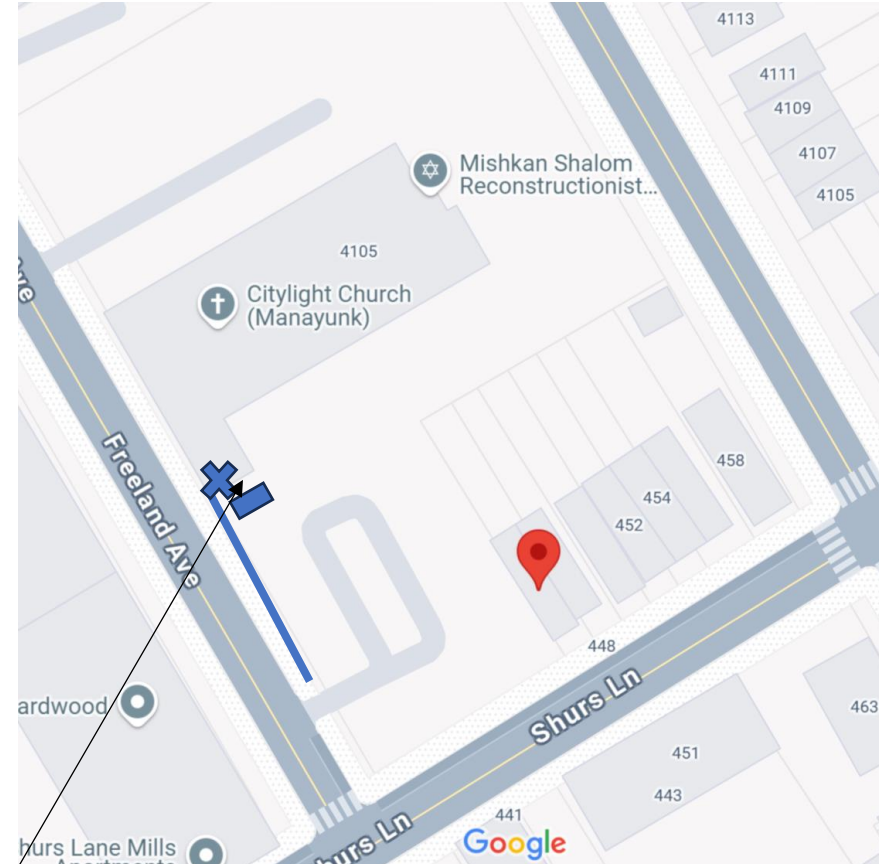
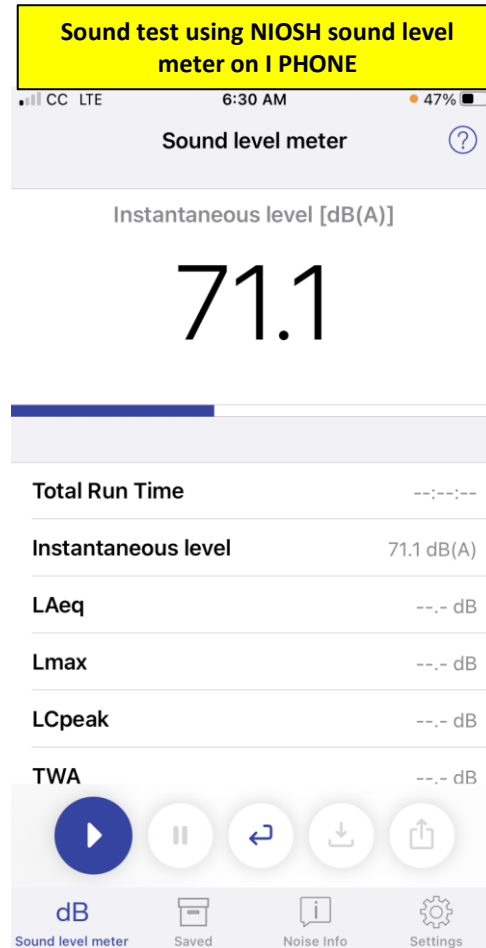

71.1 dB behind transformer in corner between the synagogue's wall and the retaining wall

# Sound Level Reading - Mishkan Shalom Parking Lot

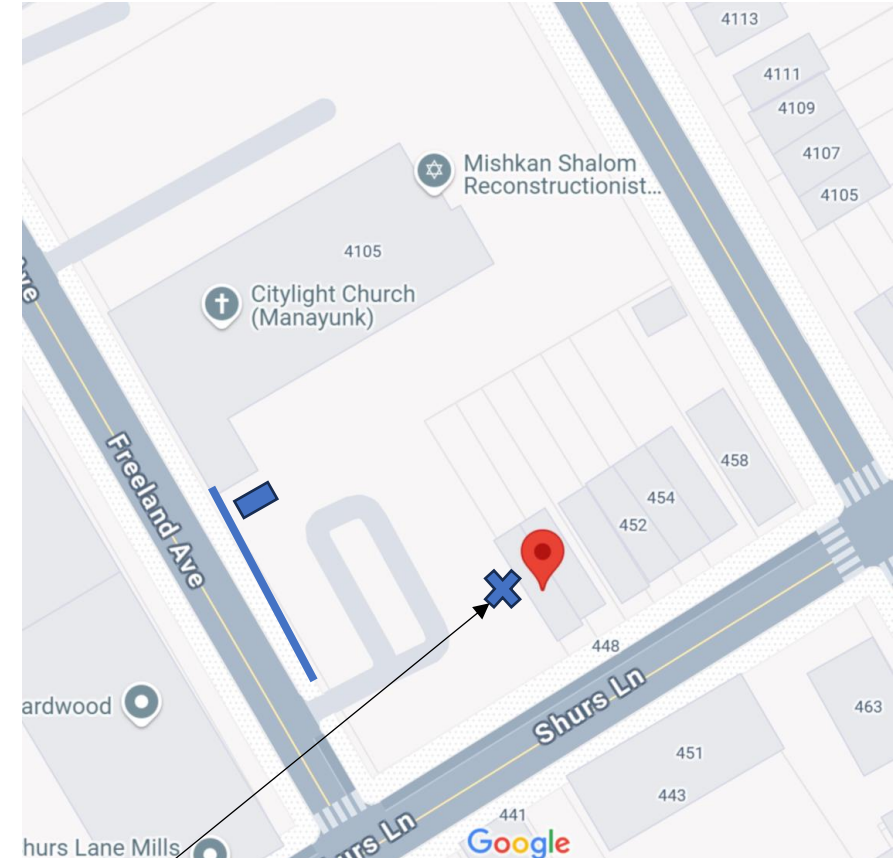
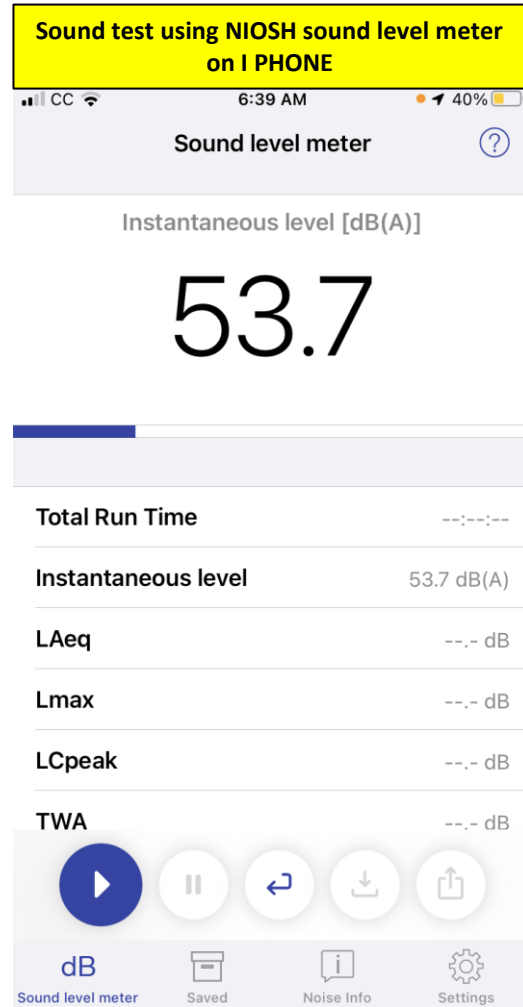

53.7 dB at approx. 65 ft from transformer in parking lot midway down the house line

# Sound Level Reading - Mishkan Shalom Parking Lot

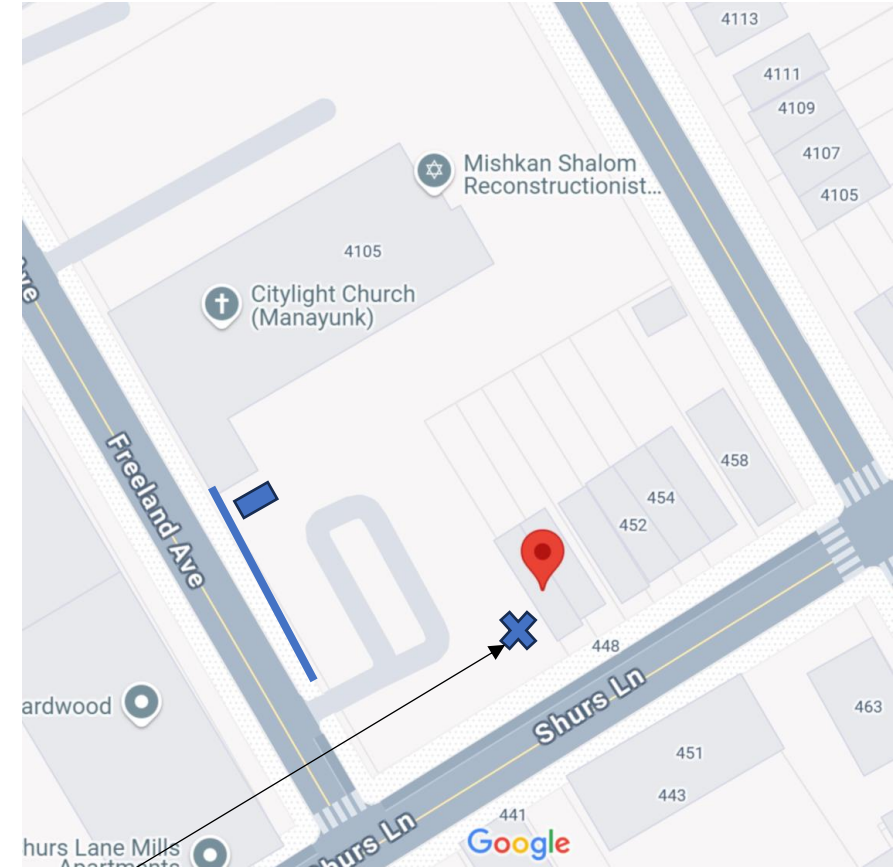
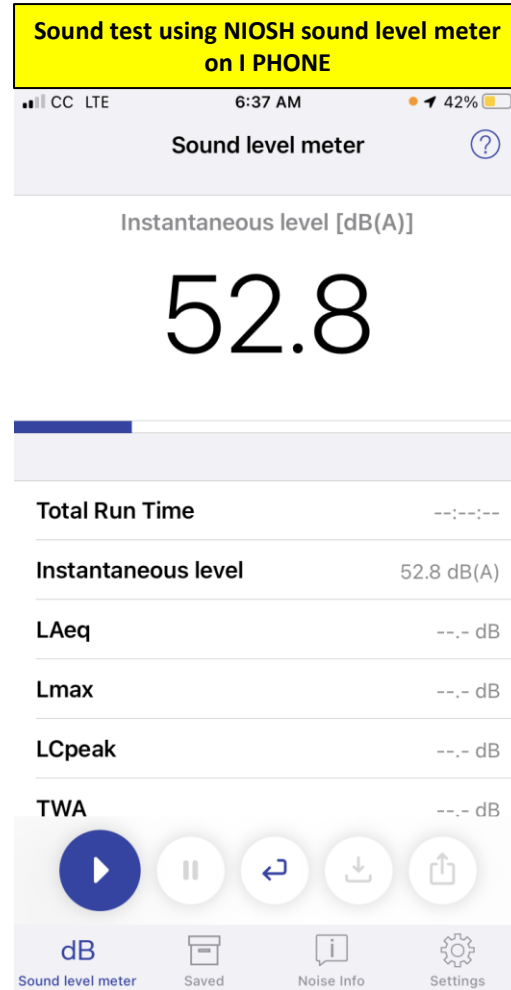

52.8 dB at 80 ft from transformer in far corner of parking lot

# Sound Level Reading - Outside of Mishkan Shalom's Lot

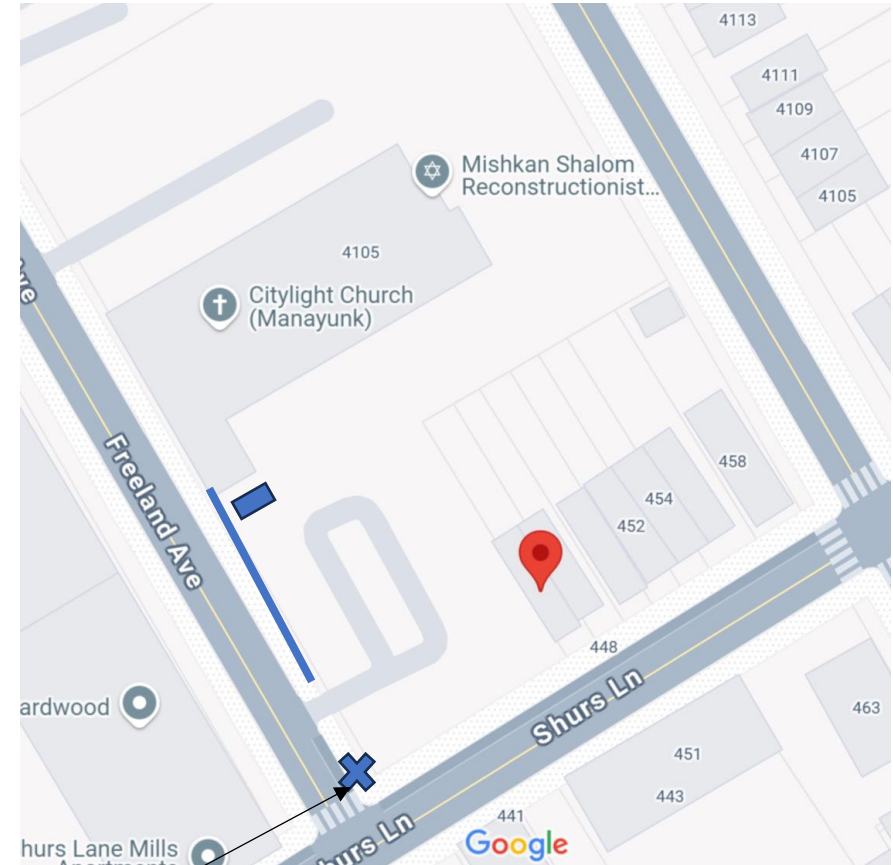
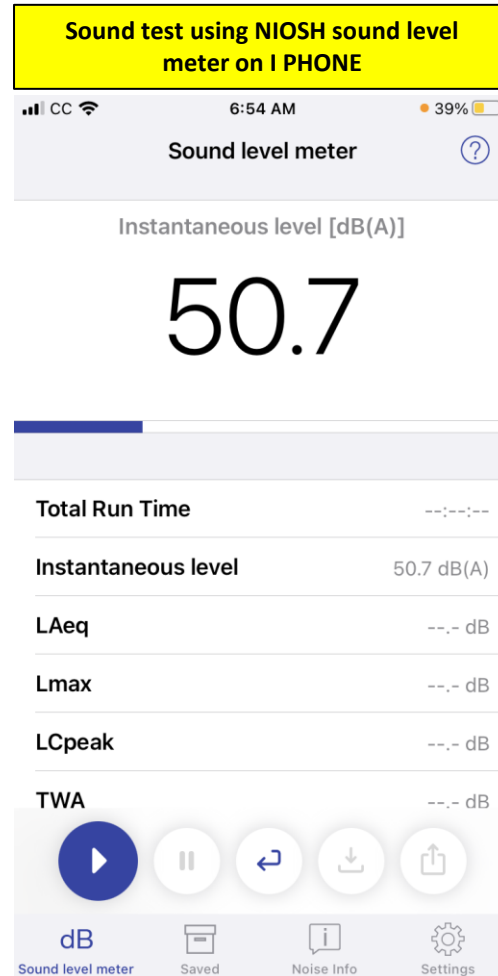

50.7 dB at 65 ft from transformer standing outside of the parking lot at corner of Shurs Lane and Freedland ave

# Sound Level Reading - On Back Deck of House

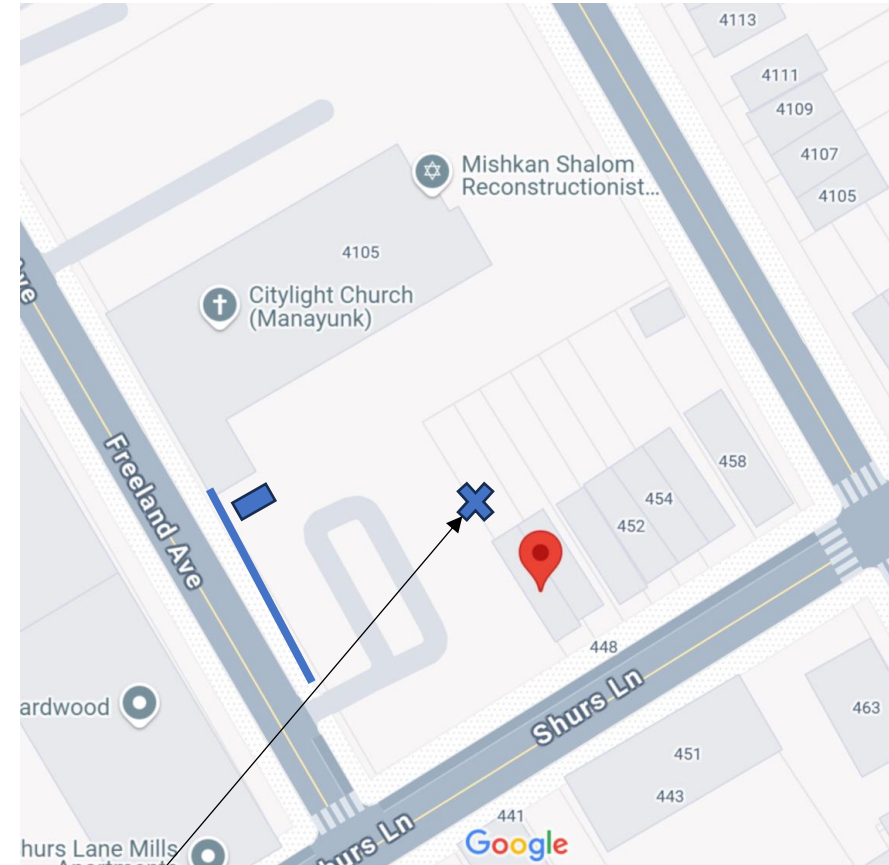
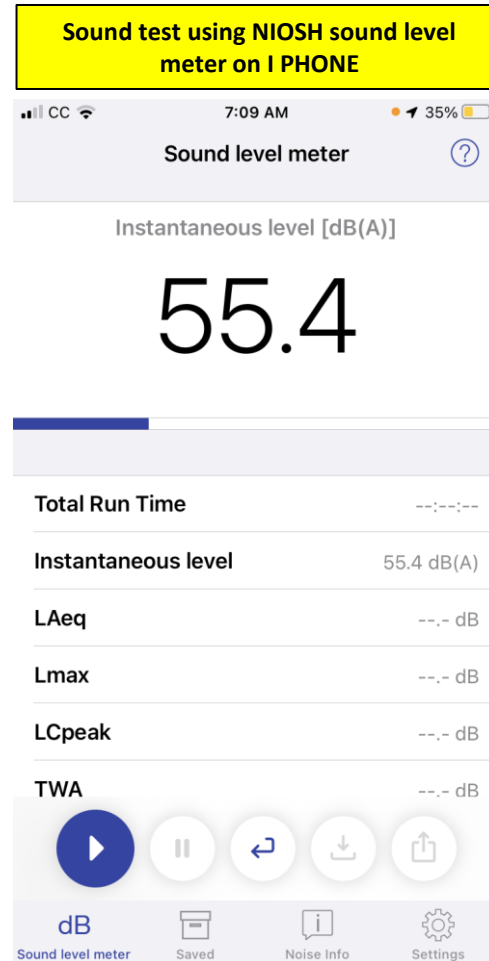

55.4 dB standing on back deck behind house approx. 65-70 ft from transformer

# Sound Level Reading – at 1st Floor Back Door & Windows

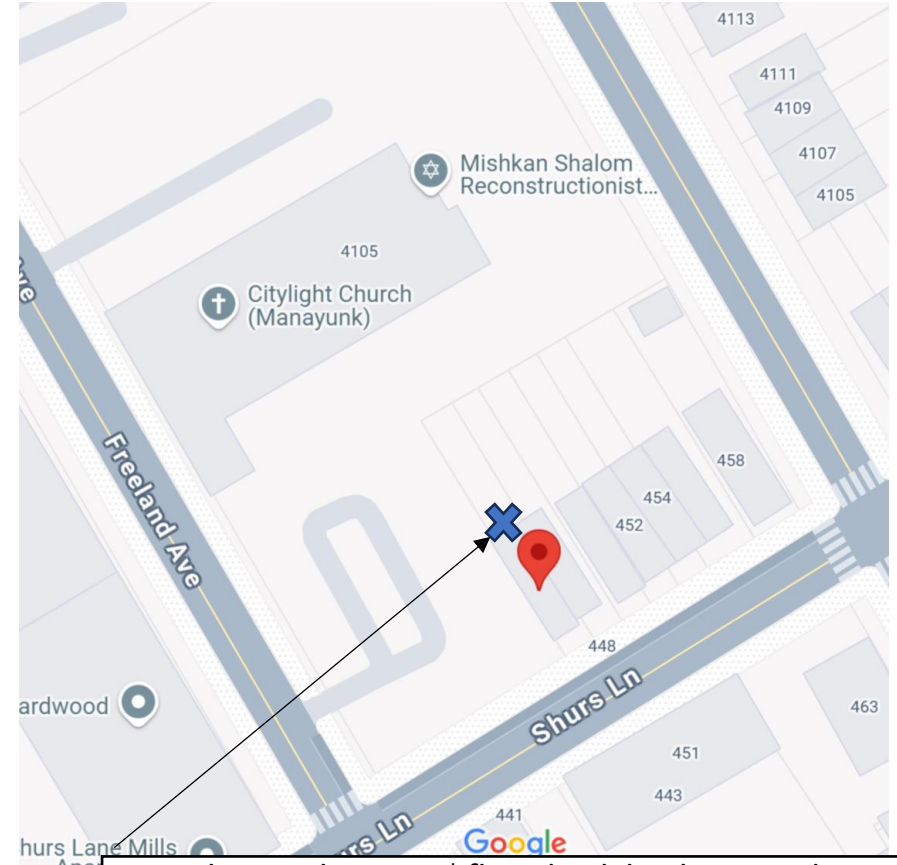
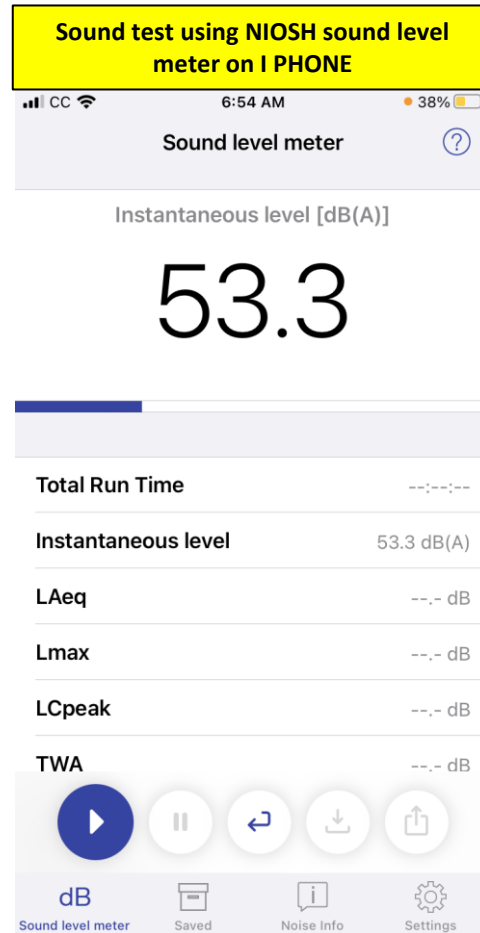

53.3 dB standing at 1<sup>st</sup> floor back kitchen window and doors approx. 70 ft from transformer

# Sound Level Reading - 1<sup>st</sup> floor Kitchen / Dining Room

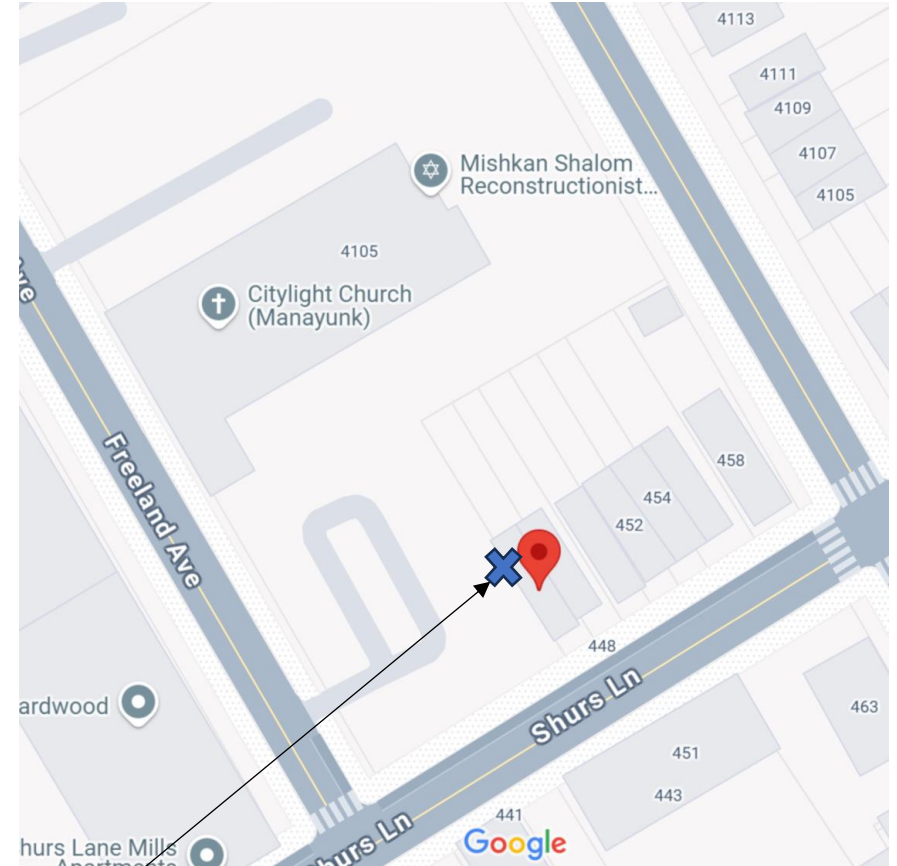
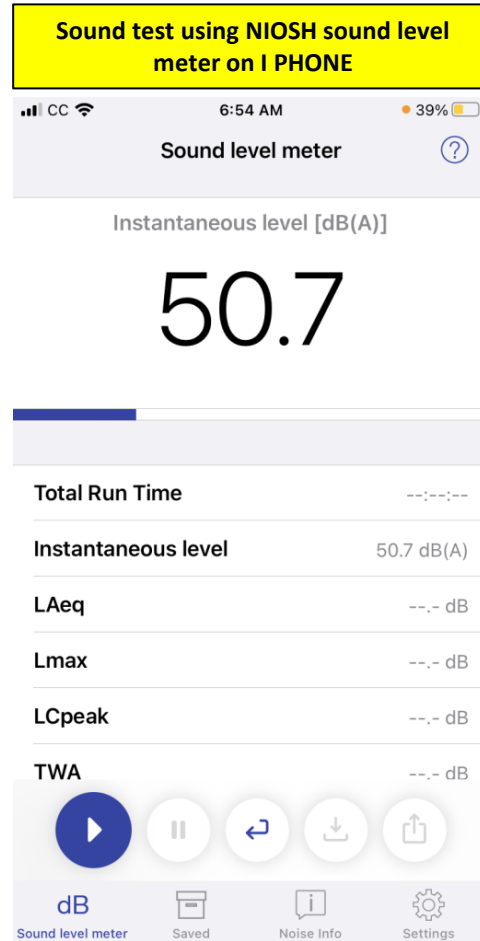

50.7 dB standing at 1<sup>st</sup> floor dining room window approx. 70 ft from transformer

# Sound Level Reading - House Second Floor Office

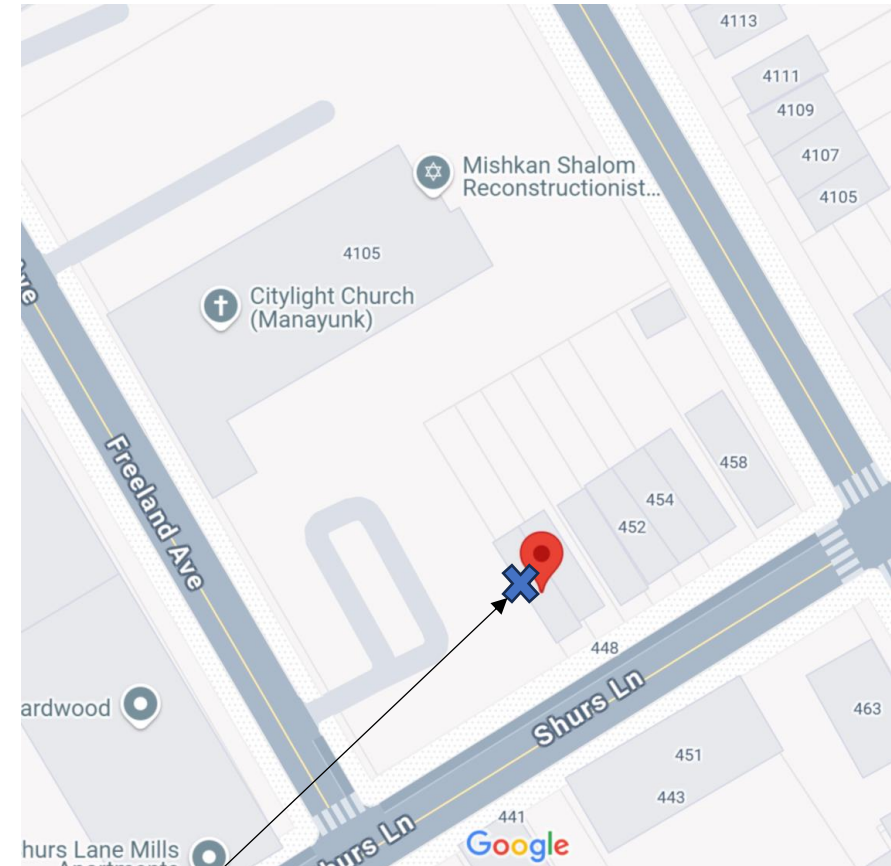
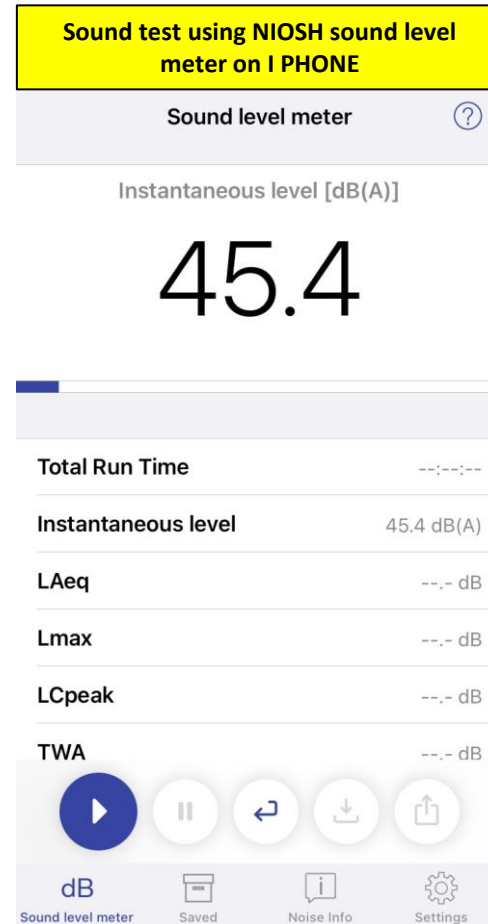
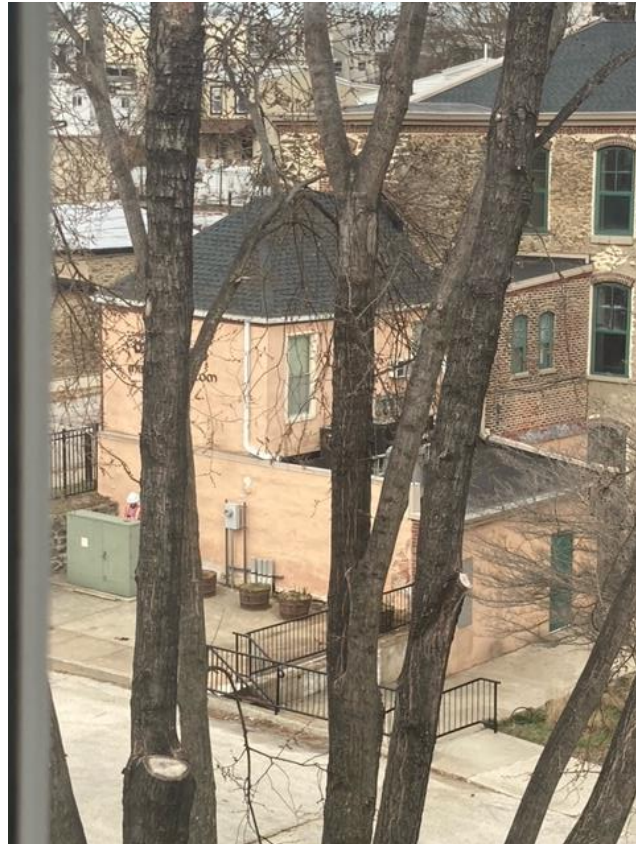

Constant noise directed and reflected at our entire property

45.4 dB at ft 2<sup>nd</sup> floor office window approx. 85 ft from transformer

C-2024-3050908

# Other PECO Pad Mount Transformers Are Much Quieter

- Example 1 of quieter PECO transformer within 2 Blocks of 446 Shurs Lane
- Pad mount transformer in parking lot of AFC Urgent Care at Ridge and Shurs, it is not placed in a high walled corner
- Sound reading of approx. 40 db. standing right next to transformer next to transformer
- **The transformer in Mishkan Shaloms parking (at 65-70 dB's) is 62% louder than this transformer**

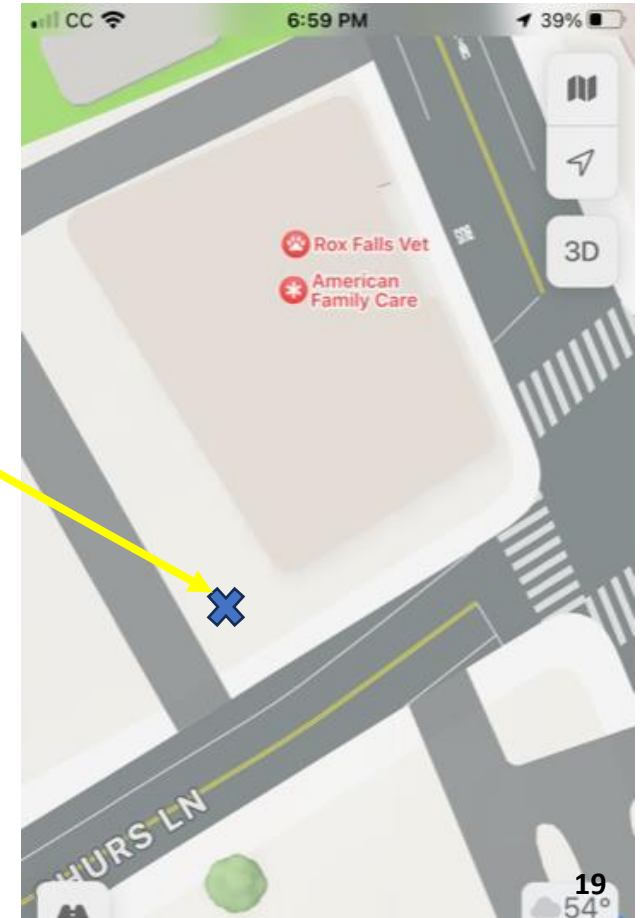

# Other PECO Pad Mount Transformers Are Much Quieter

- Example 2 of quieter transformer within 2 Blocks of 446 Shurs Lane
- Pad mount transformer in parking lot of the View Apartments at 4136 Mitchell St, it is not placed in high walled corner
- Sound reading of approx. 35-40 db. standing right next to transformer next to transformer
- **The transformer in Mishkan Shaloms parking (at 65-70 dB's) is 62% louder than this transformer**
- You can not hear this transformer until you are standing right next to it

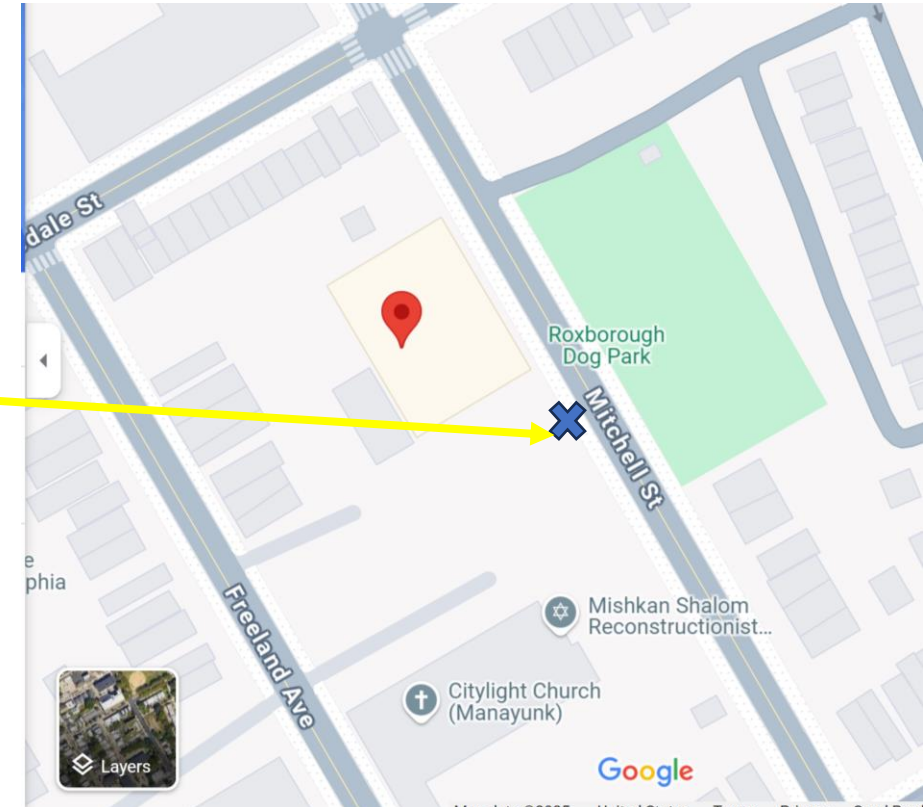

# Other PECO Pad Mount Transformers Are Much Quieter





 **Khadijah: Scott** 11/19/24  
To: Bart, Teri-Lee Cc: Renee >

Good afternoon Mr. Lawrence,

PECO did inspect the property approximately two weeks after our conference call. The design consultant and engineer did state that the padmount transformer at issue was humming louder than other padmounts in the area. However, there was construction nearby so they were unable to identify if it could be heard at a distance. They intended to return at a later date after construction would be completed. I intended to provide an update on the next mediation report date of December 2<sup>nd</sup> after they had an opportunity to return.

I understand your request to move forward with a formal complaint hearing. PECO has no objection. In the interim, I will still have the engineers return to the property to identify if there is a solution to your concern.

Enjoy your day,  
Khadijah

- PECO Admits that their transformer at 4101 Freeland street is humming louder than other transformers in the area
- **This transformer is humming 75% to 100% louder than similar transformers (not placed in corners) located within a 2- block radius**

# Corner Placement May Violate NEC - Transformer Might be too Close to Building

Transformer is only 4 ft from synagogue's wall



transformer?

How far does a transformer need to be from a wall?

10 feet

Space separation for transformers shall be as follows: Transformer pad locations shall be a minimum of **10 feet (3 m)** from any building, building overhangs, canopies, exterior walls, balconies, exterior stairs and/or walkways connected to the building.

<https://up.codes>

**604.12 Separation From Transformers - UpCodes**

Can you cover a pad mounted transformer?

Where is your transformer located?

Where does transformers take place at?

What is the 25 foot rule for

Q should pad mounted transformwr be placed in c

installed away from corners, walls, or ceilings.

<https://www.eaton.com> PDF

Best practices for the installation and inspection of dry-type distribution ...

About featured snippets Feedback

People also ask

Where do you put a pad-mounted transformer?

PADMOUNT OIL-INSULATED TRANSFORMERS IN SIZES ABOVE 100kVA SHALL BE LOCATED A **MINIMUM OF 10' FROM THE BUILDING WALL OR ADHERE TO THE CLEARANCE FROM BUILDING DOORS, WINDOW AND OTHER OPENINGS AS SET FORTH FOR NON-COMBUSTIBLE WALLS, IF APPLICABLE.**

<https://www.mnpower.com>

**PADMOUNT TRANSFORMERS NEAR BUILDINGS - Minnesota Power**

Where should transformers be placed?

Q should pad mounted transformwr be placed in c

# Noise Disrupts Quiet Enjoyment of Outdoor Living Spaces

- Transformer noise disrupts our quiet enjoyment of 750 sq ft. of Back Deck and Backyard outdoor living

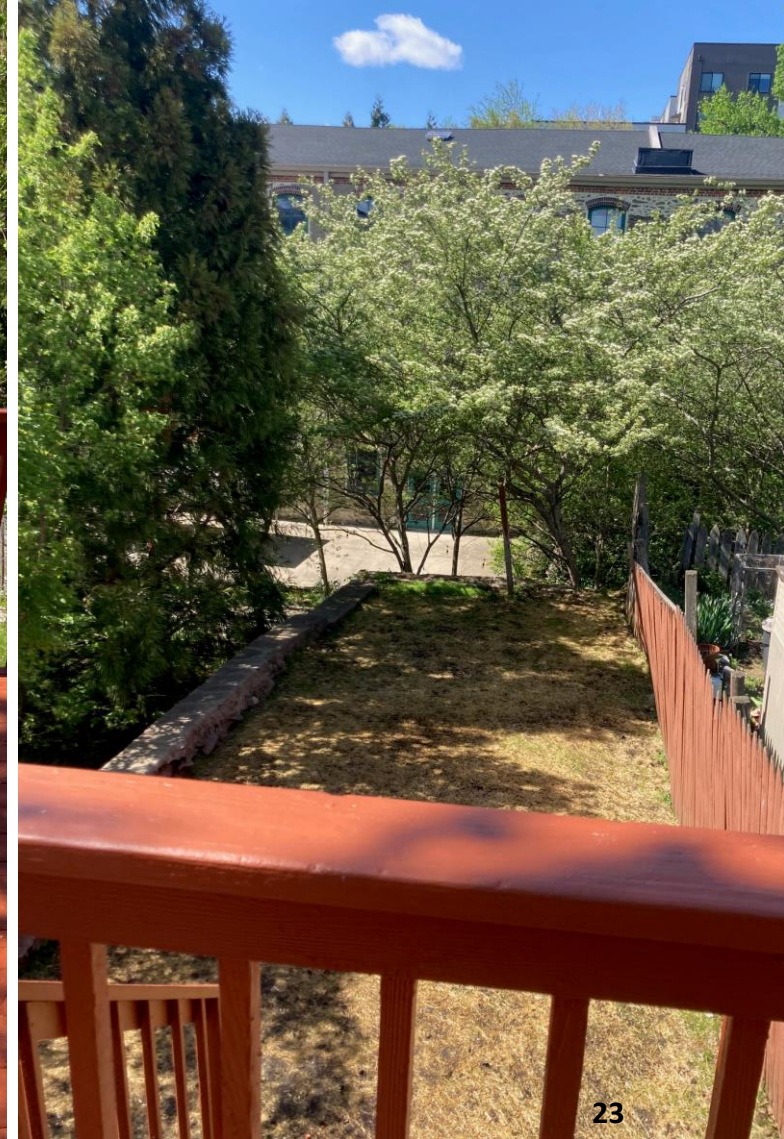
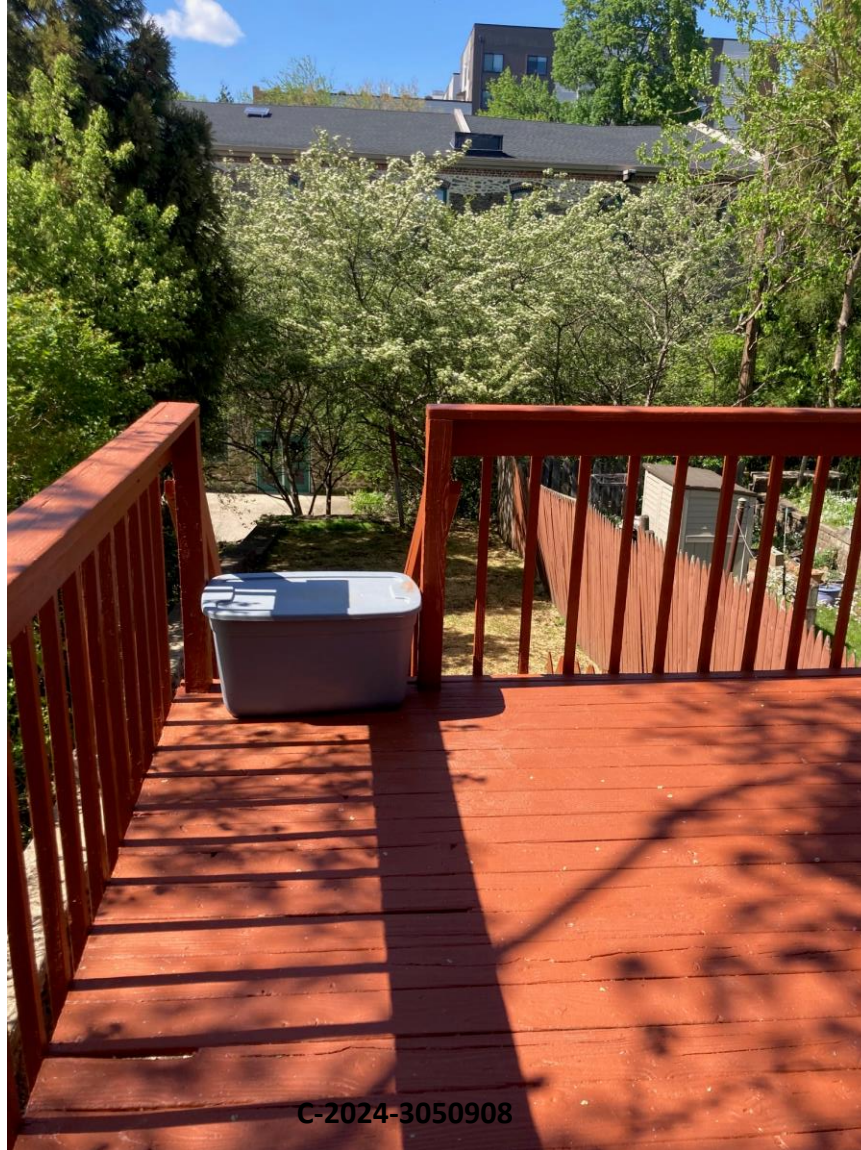

# PECO Transformer Violates Section 3 of 10-403, Philadelphia's Noise Ordinance

PECO & Mishkan Shalom installed their transformer in high walled corner creating noise issues

- Installed against Transformer Manufacturer's written installation instructions
- Installed against industry's accepted best practices
- **Violates Section 3 of 10-403, "of more than 5 dB above background measured at property line of nearest occupied property"**



PA > Philadelphia > The Philadelphia C... > § 10-403. Prohibited Conduct.

**§ 10-403. Prohibited Conduct. 85**

(1) *Sound Near Protected Facilities.* No person shall create or cause, or permit the creation of, sound that exceeds 3 decibels above background level measured at the property boundary of any hospital, nursing home, house of worship, courthouse, school, library or day care facility. This provision shall apply, notwithstanding the potential applicability of a less restrictive standard in this Chapter.

(2) *Sound From Residential Properties.* No person shall create or cause, or permit the creation of, sound originating from a residential property audible at a distance greater than one hundred feet from the property boundary or that exceeds 3 decibels above background level measured beyond the property boundary except for the following:

- (a) the operation of lawn maintenance equipment between the hours of 8 a.m. and 8 p.m., provided the equipment is functioning within manufacturer's specifications and with sound-reducing equipment in use and in proper operating condition;
- (b) sound originating from an air conditioning or refrigeration unit or system; sound from such a source shall not exceed:
  - (1) 5 decibels above background level measured at the property boundary of the nearest occupied residential property;
  - (2) 10 decibels above background level measured at the property boundary of the nearest occupied non-residential property;
- (c) sound from animals, to which the restrictions of subsection (6) apply; and
- (d) the unamplified human voice.

(3) *Sound From Non-Residential Properties.* No person shall create or cause, or permit the creation of, sound originating from a property used for a non-residential purpose that exceeds:

- (a) 5 decibels above background level measured at the property boundary of the nearest occupied residential property; or
- (b) 10 decibels above background level measured at the property boundary of the nearest occupied non-residential property.

(4) *Special Assembly Occupancies.* No person shall create or cause, or permit the creation of, sound originating from a special assembly occupancy, as defined under [Subcode B](#) (The Building Code) of [Title 4](#) of this Code, audible at a distance greater than one hundred feet from the property boundary of such special assembly occupancy. This subsection shall apply regardless whether it is more restrictive than the limitations imposed by subsection (3) of this Section.

(5) *Sound From Concert Venues and Stadia.* No person shall create or cause, or permit the creation of, sound originating from a concert venue or stadium that contributes to a total sound level, exclusive of extraneous sounds, that exceeds 70 decibels measured at the property boundary of the nearest occupied residential property.

< Previous Doc C-2024-3050908 Next Doc > 24

# PECO Transformer Emits 15 dB above background noise at Property Line - **Violates Philadelphia's Noise Ordinance**

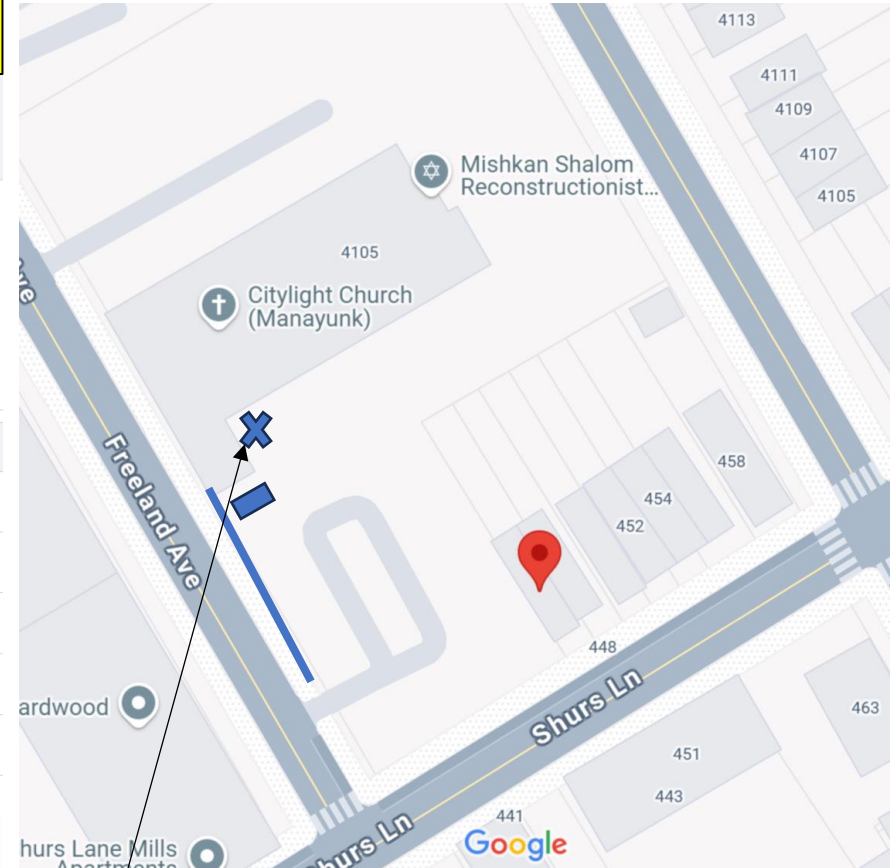
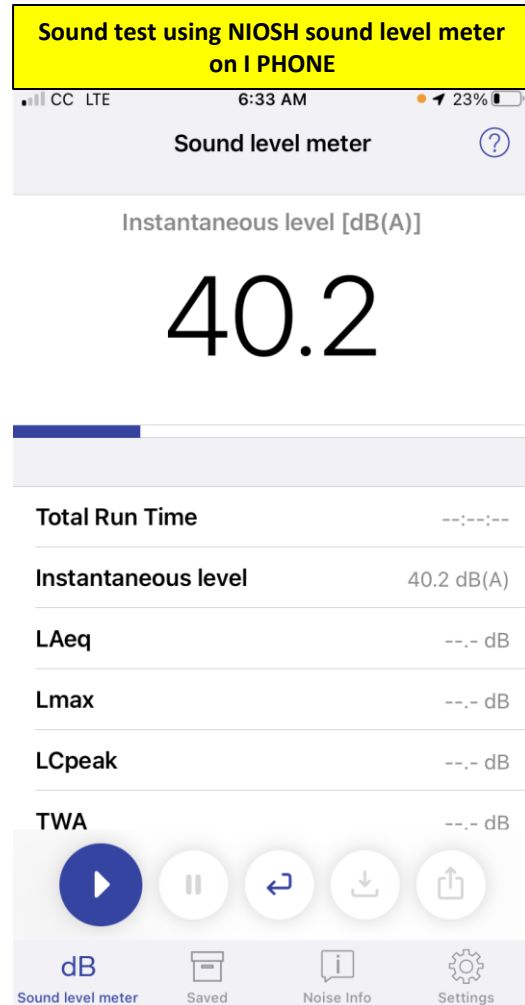
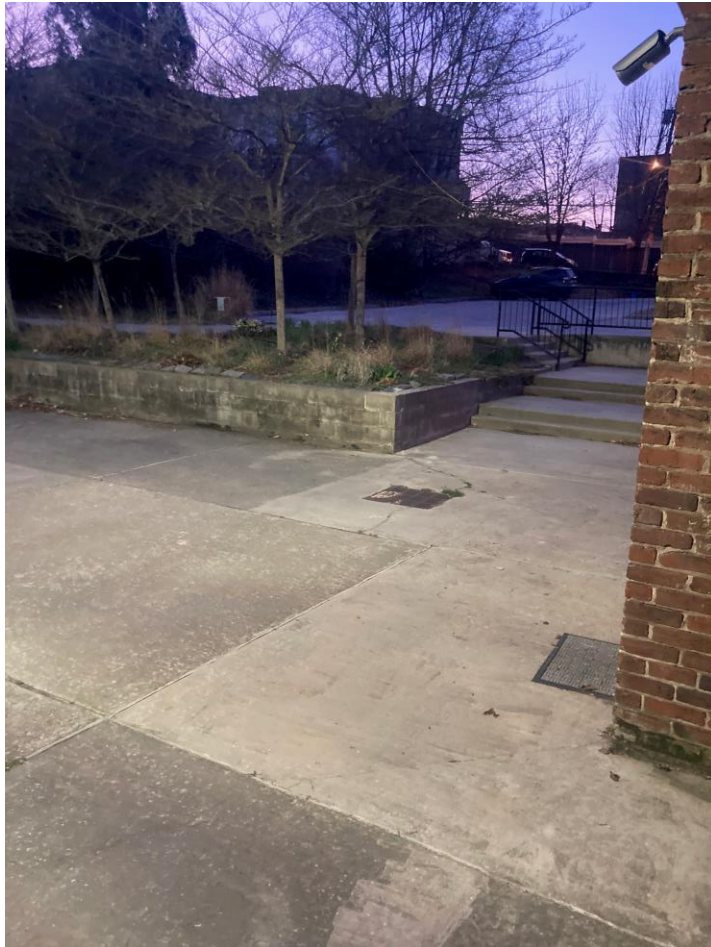

**Establishing background noise levels –take readings along synagogue wall shielded from transformer noise by a wall**  
40.2 dB at corner 5ft from transformer **25**

# PECO Transformer Emits 15 dB above background noise at Property - **Violates Philadelphia's Noise Ordinance**

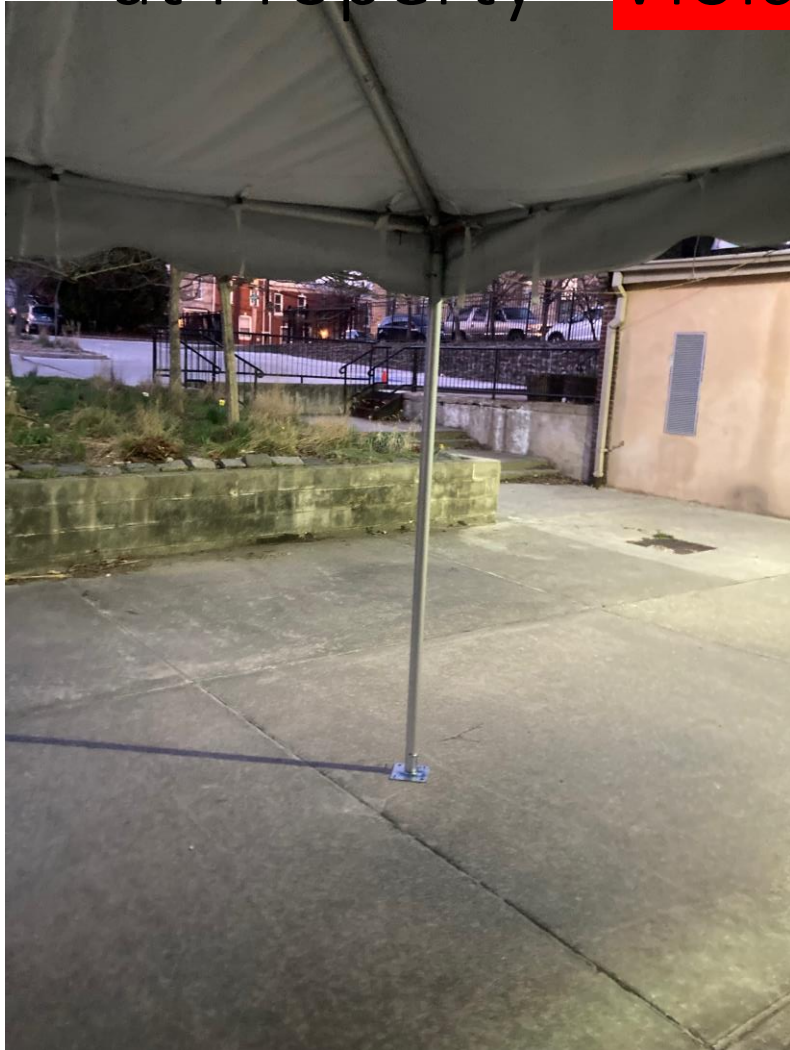

Sound test using NIOSH sound level meter on I PHONE

CC LTE 6:37 AM 21%

Sound level meter

Instantaneous level [dB(A)]

# 39.1

Total Run Time	--:--:--
Instantaneous level	39.1 dB(A)
L <sub>Aeq</sub>	--. dB
L <sub>max</sub>	--. dB
L <sub>Cpeak</sub>	--. dB
TWA	--. dB

dB Sound level meter Saved Noise info Settings

C-2024-3050908

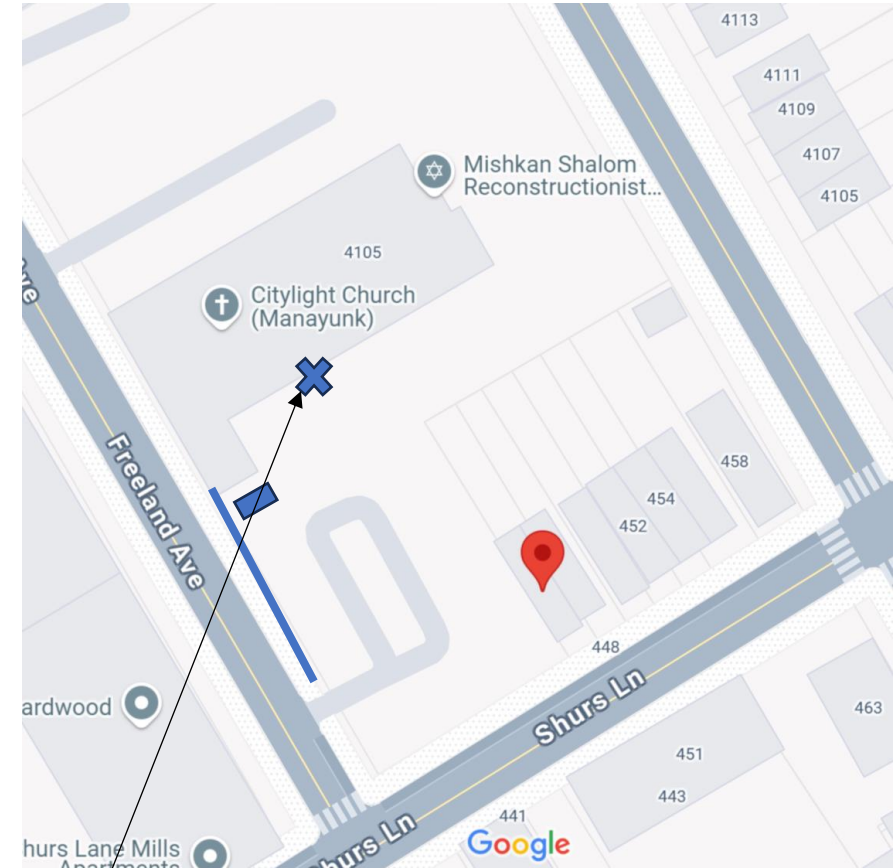

**Establishing background noise levels –take readings along synagogue wall shielded from transformer noise by a wall 39.1 dB along synagogue wall shielded by corner 10-15ft from transformer**

# PECO Transformer Emits 15 dB above background noise at Property Line - Violates Philadelphia's Noise Ordinance

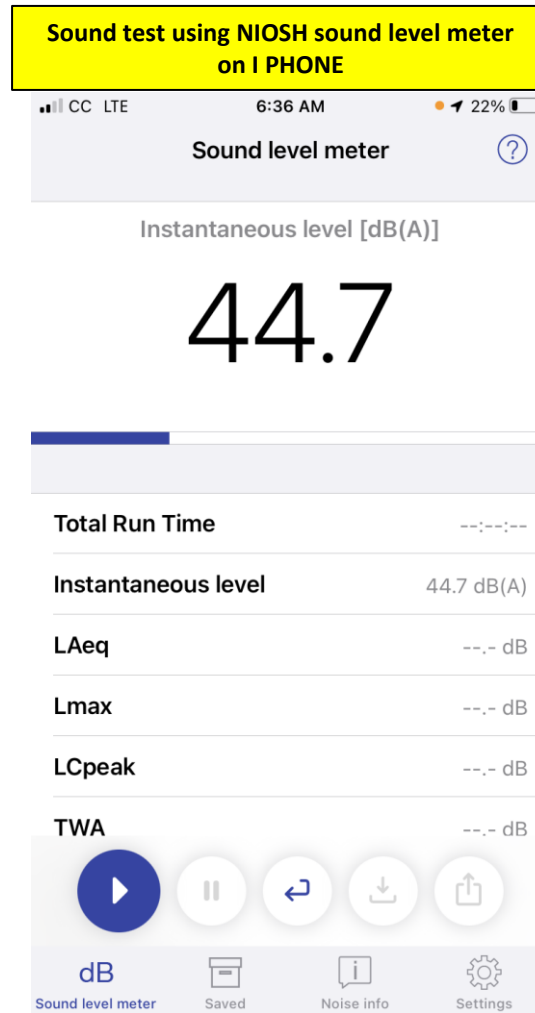

C-2024-3050908

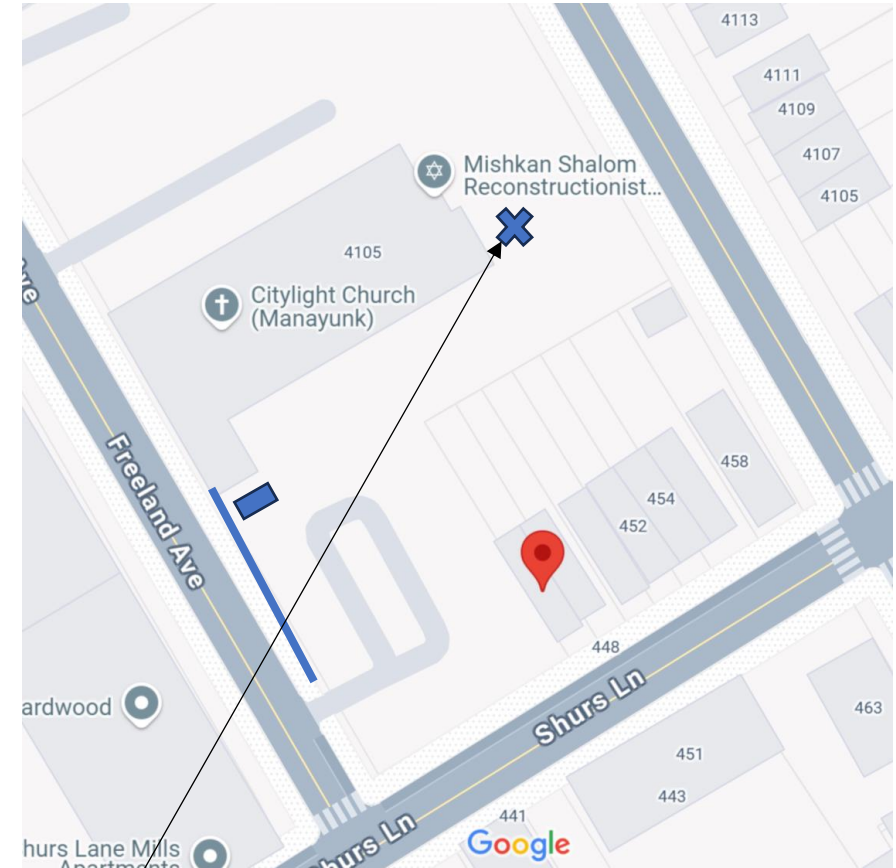

Establishing background noise levels –take readings along synagogue wall shielded from transformer noise by a wall 44.7 dB on side of synagogue wall shielded by 2 corners 20-40 ft from transformer

# PECO Transformer Emits 15 dB above background noise at Property Line - **Violates Philadelphia's Noise Ordinance**

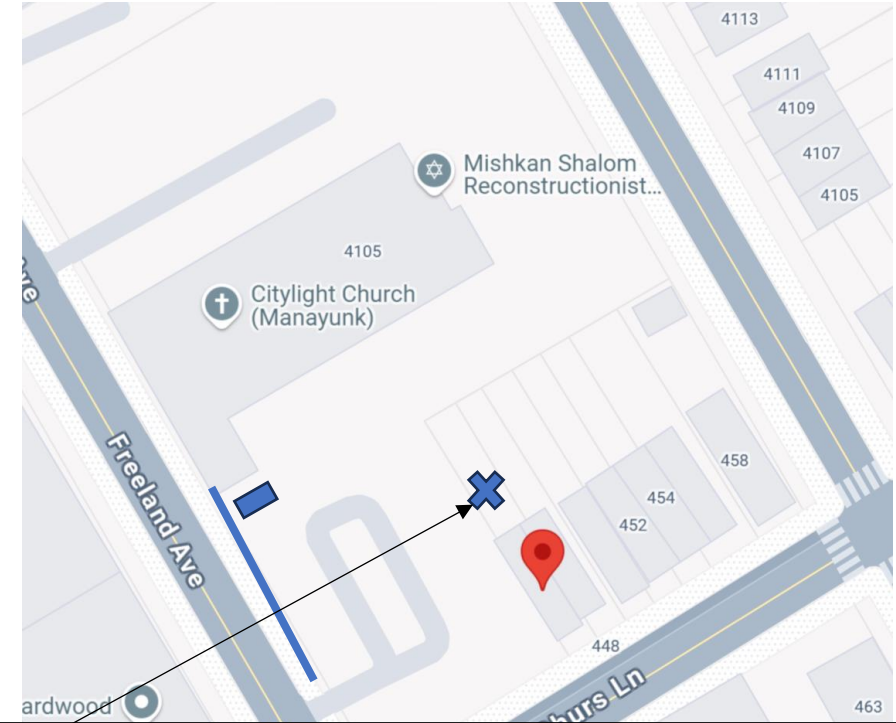
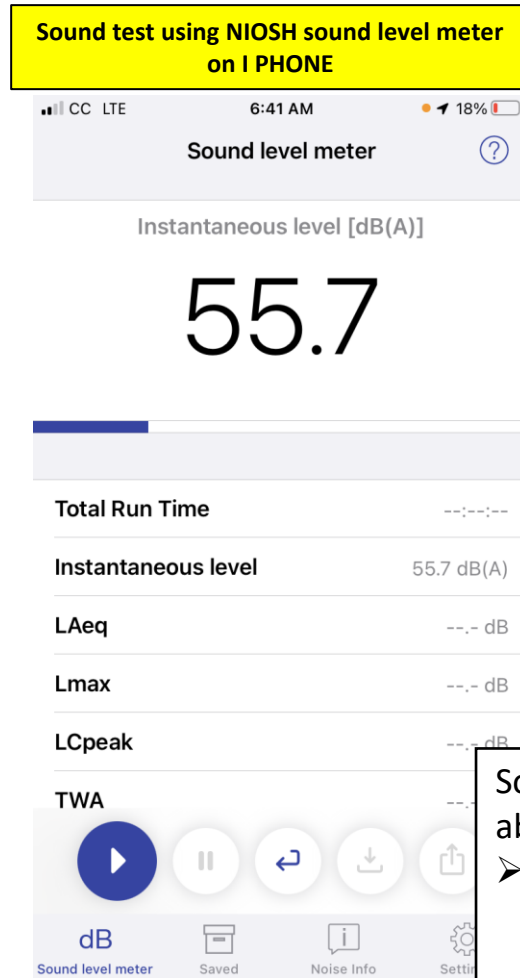

Sound reading is 55.7 dB at our property line standing in our backyard about 55-60 ft from transformer

- **PECO Transformer emits 15 dB above background noise (avg of 41.1 dB) at property line. This violates Philadelphia's Noise Ordinance which allows for sound emission from non-residential properties of no more than 5 dB at property line of nearest occupied property.**

# PECO Transformer also Violates Section 1 of 10-403, Philadelphia's Noise Ordinance

PECO & Mishkan Shalom installed their transformer in high walled corner creating noise issues

- Installed against Transformer Manufacturer's written installation instructions
- Installed against industry's accepted best practices
- **Transformer itself Violates Section 1 of 10-403, being installed on a "protected facility" a "house of worship"**



PA > Philadelphia > The Philadelphia C... > § 10-403. Prohibited Conduct.

§ 10-403. Prohibited Conduct. 85

(1) *Sound Near Protected Facilities.* No person shall create or cause, or permit the creation of, sound that exceeds 3 decibels above background level measured at the property boundary of any hospital, nursing home, house of worship, courthouse, school, library or day care facility. This provision shall apply, notwithstanding the potential applicability of a less restrictive standard in this Chapter.

(2) *Sound From Residential Properties.* No person shall create or cause, or permit the creation of, sound originating from a residential property audible at a distance greater than one hundred feet from the property boundary or that exceeds 3 decibels above background level measured beyond the property boundary except for the following:

- (a) the operation of lawn maintenance equipment between the hours of 8 a.m. and 8 p.m., provided the equipment is functioning within manufacturer's specifications and with sound-reducing equipment in use and in proper operating condition;
- (b) sound originating from an air conditioning or refrigeration unit or system; sound from such a source shall not exceed:
  - (1) 5 decibels above background level measured at the property boundary of the nearest occupied residential property;
  - (2) 10 decibels above background level measured at the property boundary of the nearest occupied non-residential property;
- (c) sound from animals, to which the restrictions of subsection (6) apply; and
- (d) the unamplified human voice.

(3) *Sound From Non-Residential Properties.* No person shall create or cause, or permit the creation of, sound originating from a property used for a non-residential purpose that exceeds:

- (a) 5 decibels above background level measured at the property boundary of the nearest occupied residential property; or
- (b) 10 decibels above background level measured at the property boundary of the nearest occupied non-residential property.

(4) *Special Assembly Occupancies.* No person shall create or cause, or permit the creation of, sound originating from a special assembly occupancy, as defined under [Subcode B](#) (The Building Code) of [Title 4](#) of this Code, audible at a distance greater than one hundred feet from the property boundary of such special assembly occupancy. This subsection shall apply regardless whether it is more restrictive than the limitations imposed by subsection (3) of this Section.

(5) *Sound From Concert Venues and Stadia.* No person shall create or cause, or permit the creation of, sound originating from a concert venue or stadium that contributes to a total sound level, exclusive of extraneous sounds, that exceeds 70 decibels measured at the property boundary of the nearest occupied residential property.

C-2024-3050908

< Previous Doc > Next Doc >

# Synagogue is adding **240** 400W Solar Panels(**96000W**) to Roof

**July 2025 Synagogue installs 240 6ft 400W solar panels and inverters to roof which are tied to this already Noisy transformer**

- This additional 96 KW of Solar load to this already noisy transformer. This has potential to make PECO noisy ground mount pad transformer even noisier. Also 240 inverters used on this solar power install may introduce harmonics affecting power quality thereby increasing noise emitted from this transformer
- Around the time of this install on 7/21/25 PECO volunteers to conduct sound study and replace transformer if out of NEMA standard, this is 7 days prior to the initial formal complaint hearing scheduled 7/29/25
- 7/22/25 Bart Lawrence informs PECO to factor this large grid tied Solar panel installation into their sound testing
- **Did PECO review and approve this large solar power installation and its additional load on this transformer?**



C-2024-3050908

# Insulating Row House Will Not Stop Excess Noise & is Costly

- \$15K to \$20K to insulate a corner row house
- Insulation will not block transformer noise, also house has multiple side and back windows (10 side and back windows)
- Windows are newly upgraded, replaced in 2015 house renovation
- Windows are open for ventilation in Spring, Fall and open for some of winter & summer, this increases transformer noise
- House insulation will not stop noise in outdoor living spaces; on Back Deck and in Backyard

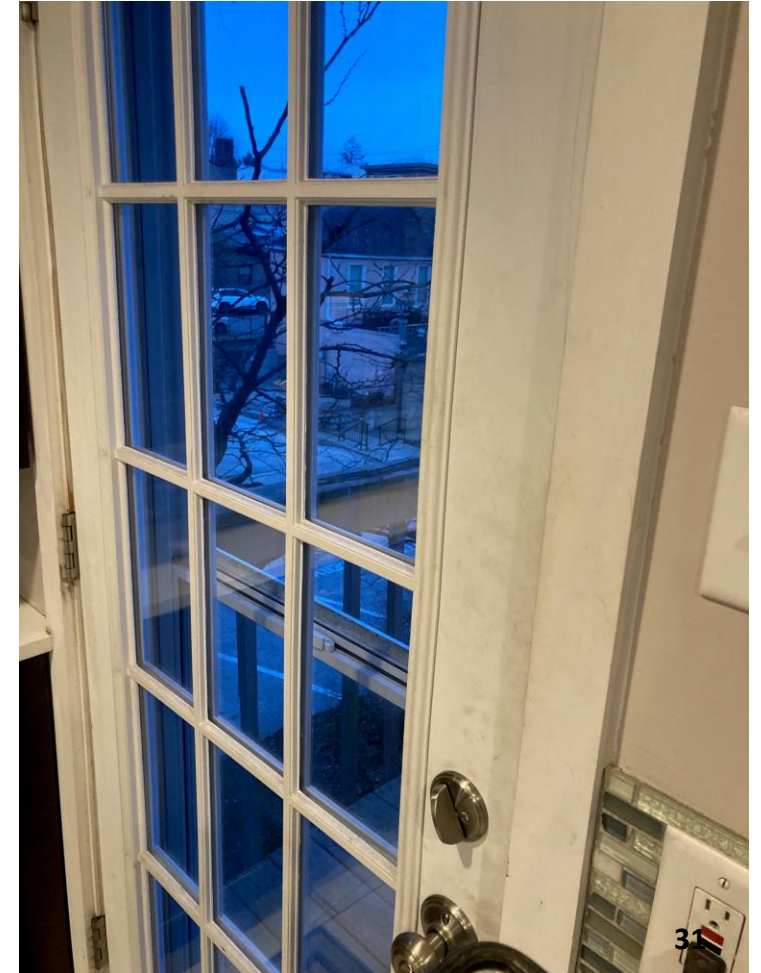
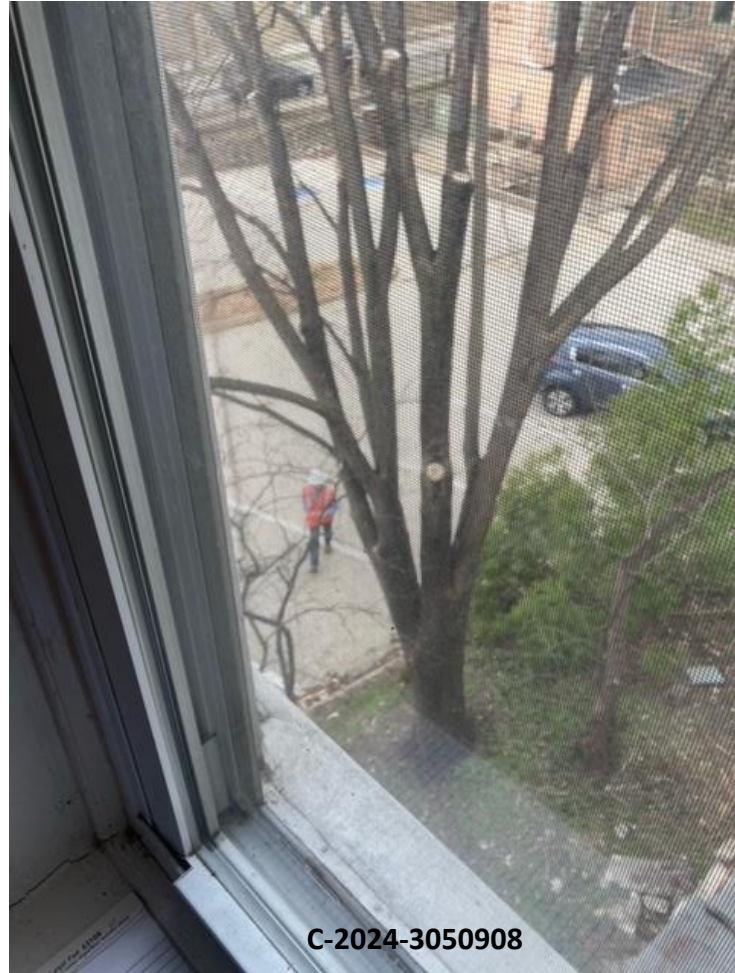

# Recommend Building High Wall(s) to Block Transformer Noise

- Build High wall along side of transformer facing property and place sound absorption material on both synagogue and parking lot retaining walls behind the transformer, or
- Build high wall U shaped enclosure around transformer, leaving front of transformer open

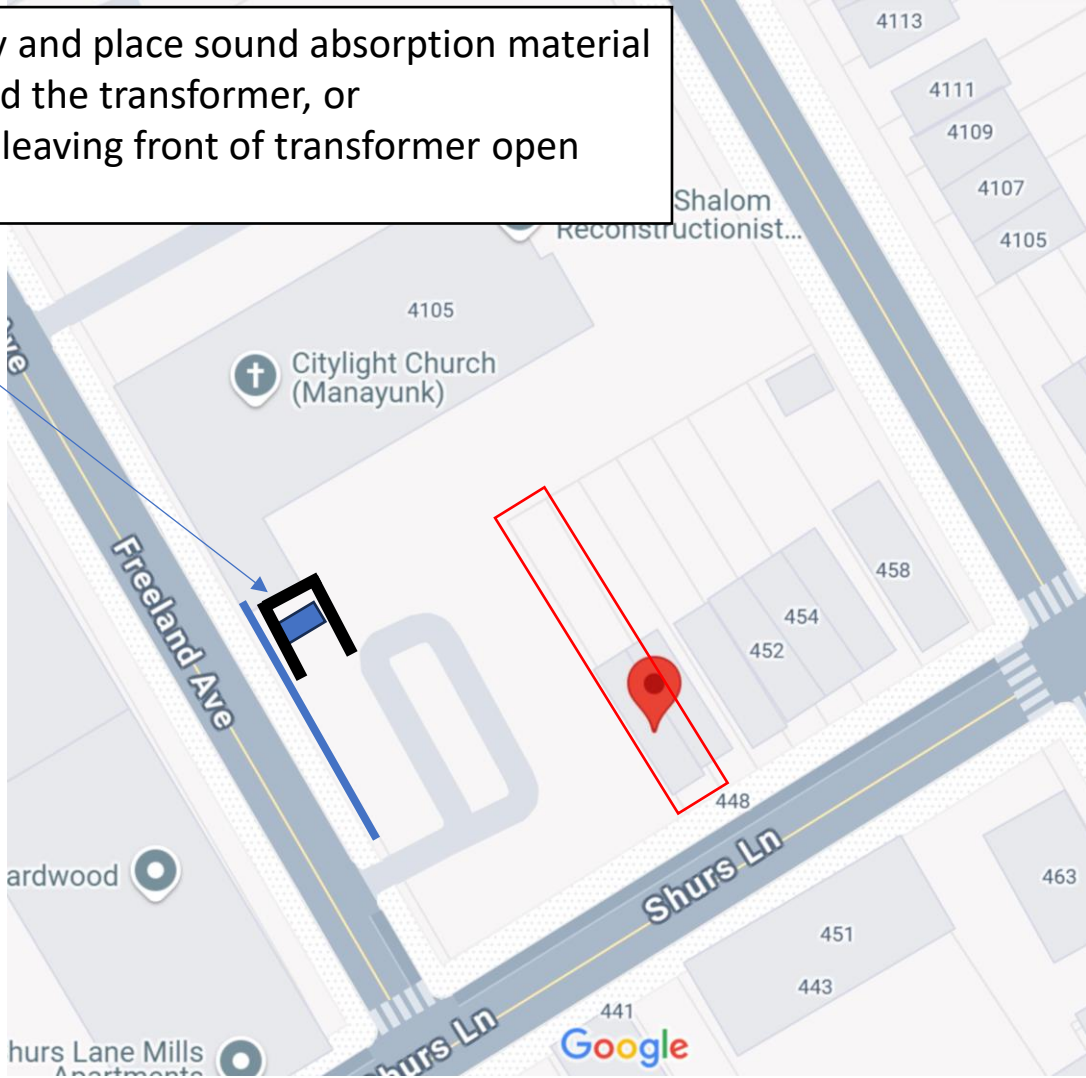

# Recommend Build Enclosure to Shield 446 Shurs from Noise

Example of an enclosure built around a PECO pad mount transformer at Pensdale village at Pensdale ave and Mitchell St



C-2024-3050908

# Recommend Building High Wall(s) to Block Transformer Noise

Example of an enclosure built around a PECO pad mount transformer, Shurs Lane Condominium at Pechin St and Shurs Lane

- PECO suggested raising transformer up to ground level
- Simpler to just build 8 ft tall U-Shaped enclosure around transformer on property

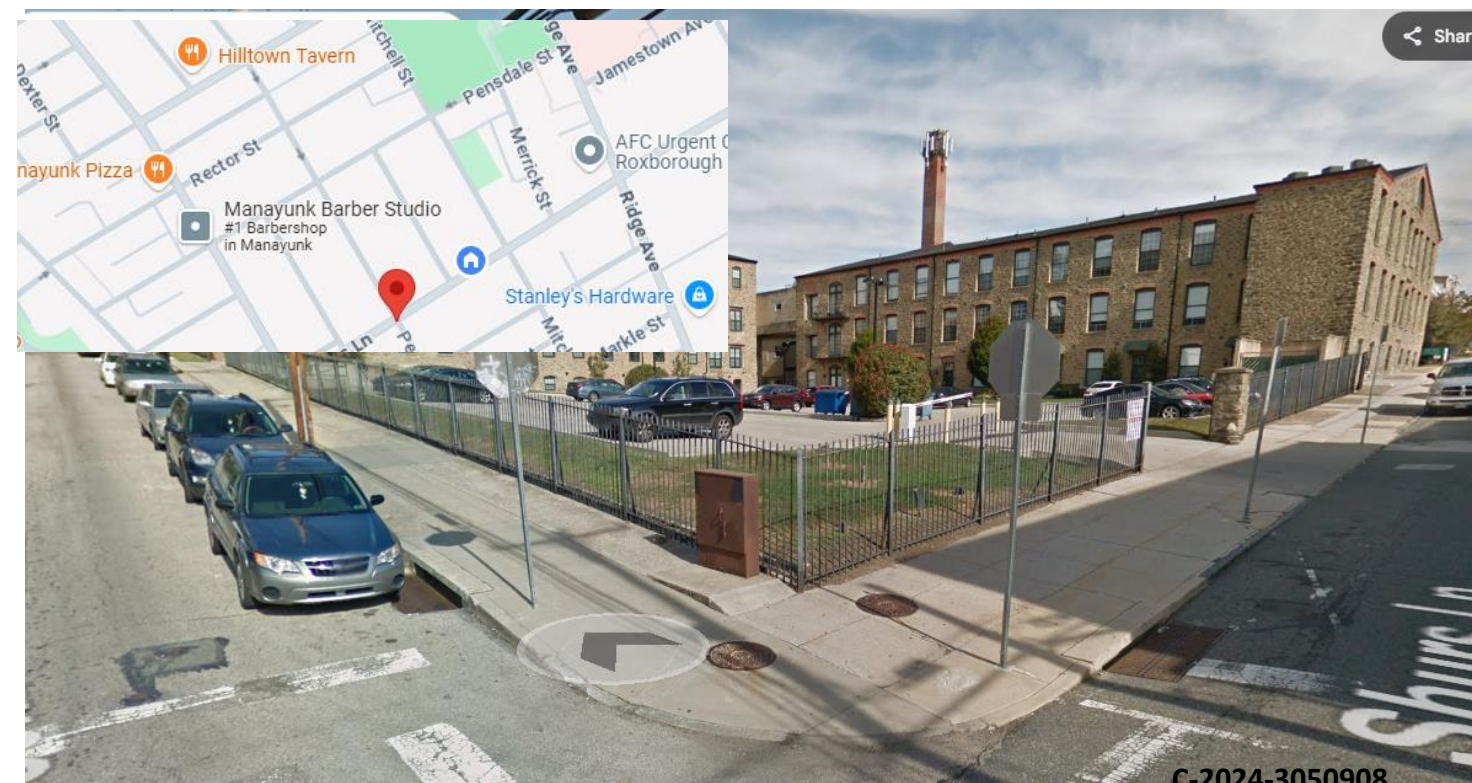

C-2024-3050908



34

# Recommend Building High Wall(s) to Block Transformer Noise

## Understanding Transformer Noise



ISO 9001:2008  
REGISTERED



To measure amounts of noise in each frequency range you need a frequency analyzer. This is a worthwhile acquisition.

It is always necessary to measure the background (ambient) noise level before you start and when you finish the tests. There has to be a difference between the ambient reading and the average noise level of 7dB or better, for it to be valid, otherwise you could be increasing the actual reading of the transformer. This sometimes makes night owls of the testers!

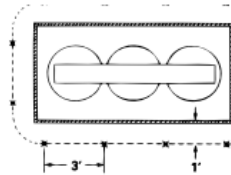

**SO NOW WE KNOW WHERE THE NOISE COMES FROM AND HOW TO MEASURE IT. WHAT CAN WE DO ABOUT IT?**

First of all, accept that there is a noise and you are stuck with it. We have to consider how to avoid making it a nuisance to people. The most obvious strategy is to place the transformer in a field miles away from habitation. The noise level drops away as the square of the distance from the noise, but even so, it would take a very large field to hide it. However, we invariably have to place transformers near people and we must face up to that fact.

We have both noise and vibration to worry about and as we have said NOISE is usually air borne, VIBRATION is structure borne.

### METHODS OF CUTTING AIR BORNE NOISE

Put the object in room in which the walls, floor are massive enough to reduce the noise to a person listening on the other side. Noise is usually reduced (attenuated) as it tries to pass through a massive wall. Walls can be of brick, steel, concrete, lead, etc.



Put the object inside an enclosure which uses a limp wall technique. This is a method which uses two thin plates separated by viscous (rubbery) material. The noise hits the inner sheet – its energy (some) is used up inside the viscous material. The outer sheet should not vibrate.

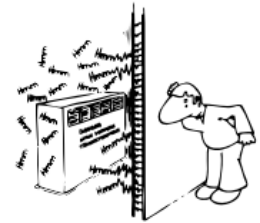

Build a screen wall around the unit. This is cheaper than a full room. It will reduce the noise to those near the wall, but the noise will get over the screen and fall elsewhere (at a lower level). Screens have been made from wood, concrete, brick and with dense bushes (although the latter becomes psychological).



Do not make any reflecting surface coincident with half the wave length of the frequency. What does this mean?

Well, every frequency has a wave length. To find the wave length in air, for instance, you divide the speed of sound, in air (generally reckoned as 1130 feet/second) by the frequency.

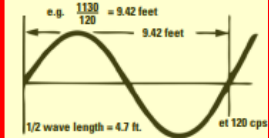

If a noise hits a reflecting surface at these dimensions it will produce what is called a standing wave. Standing waves will cause reverberations (echoes) and an increase in the sound level. If you hit these dimensions and get echoes you have to apply absorbent materials to the offending walls (fiber-glass, wool, etc.).

### METHODS OF CUTTING STRUCTURE BORNE VIBRATION

Isolate the core and coils of the transformer from the ground. In air cooled dry types this means to isolate the core and coil from its support on the ground. For an oil filled unit it means to isolate the core and coil from its tank base, and isolate its tank base from the supporting ground.

Use isolating materials guaranteed to eliminate transformer frequencies (at 120 cps upwards). This is important. Not many materials can do this. Seek advice on the best anti-vibration pads to use.

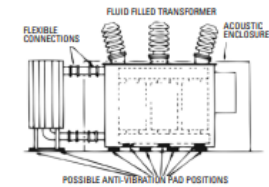

TYPICAL TRANSFORMER CONNECTIONS – DRY-TYPE TRANSFORMERS

# Recommend Building High Wall(s) to Block Transformer Noise

## Understanding Transformer Noise



### A SUMMARY - THE DO'S AND THE DON'TS

It might be useful to review the salient points and give some extra pointers:

1. **Transformer noise is difficult to change at the source.** Flux density reduction is the main thrust, but this means increased cost.
2. **Transformer core constructions help to a degree.** Reputable manufacturers will use good joints, flat steel, consistent thickness, good core supports, few bolts, etc.
3. **Transformer current loading has little or no effect** on the noise level.
4. **Placing transformers in liquid (oil) does not help** since oils are incompressible.
5. **Vibration – isolating core and coils within a tank does assist vibration isolation** although isolation of the whole tank is still needed.
6. **Noise reduction by distance is the simplest form of attenuation.** If it can be achieved without cost-excellent. Usually it cannot.
7. **Noise reduction by screens, bushes, etc., is the next simplest** but use should be made of the topography of the site. Remember the shadow effect means the noise could be heard outside the shadow of that screen.
8. **Full enclosure is usually the only option left to a troublesome transformer.**
9. **Full enclosure can be made of any material with a high mass/weight ratio.** Brick, concrete, steel have been used. Expect 25-30dBA reductions.
10. **Full enclosures using masonry products are not easily demountable.** Prefabricated concrete block is the best for this application.
11. **Steel, mass or limp panel techniques make good demountable enclosures.** A 15 – 20dBA reduction is possible with properly designed enclosures.
12. **External cooling to the enclosure requires flexible treatments to the connecting pipework.**
13. **Enclosure mounts should be separate from the transformer base – or at least, isolated somehow.**
14. **All connections - cables, etc. to enclosed transformers should be flexible.**
15. **Remember bushings vibrate and losses (acoustic) are experienced through them.** Flexible acoustic protection between enclosure and bushings are needed.
16. **Bushings used in an enclosure might have to have a longer ground sleeve to accommodate the enclosure roof distances.**
17. **Pay close attention to access doors and removable covers on enclosures.** Tight fits are essential.
18. **Watch the dimensions of rooms in which units are mounted.** Damp them if necessary, suitable
19. **Damping materials are needed if standing waves or reverberations are possible.**
20. **Choose damping materials compatible with transformer frequencies.**
21. **Carry out sound surveys before and after installations.** Remember to do a frequency analysis so that transformer noise can be differentiated.
22. **Anticipate transformer noise problems when accommodating them inside a building - especially for dry types.**
23. **Pay careful attention to removing unnecessary bolting or stiffening used originally for shipping.** Federal Pacific transformers are provided with vibration isolators under the core and coil assembly. These isolators are made ineffective during shipment by shipping bars and/or tightened bolt-down hardware. Upon installation, this shipping hardware and fasteners should be removed or loosened according to the installation manual. All other shipping hardware painted red should be removed. See installation manual for details.
24. **Remember transformers need cooling air in rooms.** Be careful (acoustically) when you position air ducts, ventilators and grilles, etc.
25. **Pay attention to flexible connections inside rooms containing transformers.**
26. **Select rooms which are not near potential complaint areas.**
27. **Check the voltage on the system.** Increased flux density by having a higher than normal system voltage will raise the noise level. Most Federal Pacific transformers are provided with tap connections to accommodate higher voltages if necessary. This will prevent the flux density from being elevated. See instruction manual for details on how to change these taps and make the connections properly
28. When assessing the required noise level of a transformer work backwards from the required noise level at a location. Consider the inefficiencies of the site.
29. Consider very carefully where transformers will be mounted. Resilient structures such as wooden mezzanines might be harmful.

It has not been possible to give all the points and suggestions that might assist a user in producing a trouble free (noise) site. However, we are always available for assistance.

The purpose of this leaflet is to make people aware of the important points. If we have encouraged users to plan ahead with their noise problems then we have succeeded.