Garrett P. Lent

glent@postschell.com
717-612-6032 Direct
717-731-1985 Direct Fax
File #: 217030

February 27, 2026

VIA ELECTRONIC FILING

Matthew L. Homsher, Secretary
Pennsylvania Public Utility Commission
Commonwealth Keystone Building
400 North Street, 2nd Floor
Harrisburg, PA 17120

**Re: Letter of Notification of Mid-Atlantic Interstate Transmission, LLC, For Approval of the 115 kV Transmission Line Relocations to Mountain Substation Project in South Middleton Township, Cumberland County, Pennsylvania
Docket No. A-2026-_____**

Dear Secretary Homsher:

Enclosed for filing on behalf of Mid-Atlantic Interstate Transmission, LLC (“MAIT”) is a Letter of Notification (“LON”) requesting approval for the 115 Kilovolt (“kV”) Transmission Line Relocations to Mountain Substation Project (“Project”). This LON is being filed pursuant to the Pennsylvania Public Utility Commission’s (“Commission”) regulations at 52 Pa. Code § 57.72(d). Copies of this LON have been served upon the parties as required by 52 Pa. Code § 57.74 and noted on the attached Certificate of Service.

Subject to the Commission’s approval, the Project has a scheduled construction date of April 27, 2026, to meet an in-service date of December 31, 2026. To support this construction timeline, MAIT respectfully requests the Commission’s expedited review and approval for the LON on or before the March 26, 2026, Public Meeting in order to allow construction to commence immediately thereafter.

Request for Special Treatment of Certain Information

Please note that the unredacted version of MAIT Exhibits 6 and 7 to the LON contain “Confidential Security Information,” for the purposes of the Public Utility Confidential Security Information Act, 35 P.S. § 2141.1-2141.6, and for the purposes of Chapter 102 of the Commission’s regulations, 52 Pa. Code §§ 102.1-102.4, and should be afforded confidential treatment as described in the statute and regulation. These exhibits also contain privileged and confidential

Matthew L. Homsher, Secretary
February 27, 2026
Page 2

information and/or critical infrastructure information (“CEII”) that should not be released pursuant to 18 C.F.R. §388.112. The unredacted versions of MAIT Exhibits 6 and 7 are labelled “CONFIDENTIAL – CONTAINS CRITICAL ENERGY INFRASTRUCTURE INFORMATION” and will be kept on file with Post & Schell, P.C. and only shared with other parties to this proceeding pursuant to a Stipulated Protective Agreement or Protective Order entered in this proceeding.

If you have any questions pertaining to this matter, please do not hesitate to contact me.

Respectfully submitted,

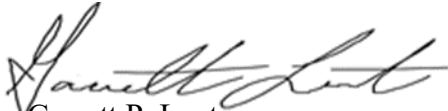
Garrett P. Lent
Principal

GPL/sa
Enclosure

cc: Deb Backer, Bureau of Technical Utilities (*via email; w/attachment*)
Jordan Van Order, Bureau of Technical Utilities (*via email; w/attachment*)
Certificate of Service

CERTIFICATE OF SERVICE

I hereby certify that a true and correct copy of the foregoing Letter of Notification has been served upon the following persons, in the manner indicated, in accordance with the requirements of 52 Pa. Code § 57.72(d)(3).

VIA CERTIFIED MAIL: RETURN RECEIPT REQUESTED

Office of Small Business Advocate
555 Walnut Street
1st Floor Forum Place
Harrisburg, PA 17101

Pennsylvania Department of
Conservation and Natural Resources
400 Market St.
Harrisburg, PA 17105

Office of Consumer Advocate
555 Walnut Street
5th Floor Forum Place
Harrisburg, PA 17101-1923

PA Department of Environmental
Protection
ATTN: Bureau of Waterways
Engineering and Wetlands
400 Market Street
Harrisburg, PA 17101

Pennsylvania Public Utility
Commission
Bureau of Investigation and
Enforcement
P.O. Box 3265
Harrisburg, PA 17105-3265

PA Department of Environmental
Protection
ATTN: Office of Chief Counsel
400 Market St., 9th Floor
Harrisburg, PA 17105
CC: Secretary to PADEP Chief
Counsel

Ms. Andrea Lowery, Executive
Director
Pennsylvania Historical & Museum
Commission
300 North Street
Harrisburg, PA 17120-0024

Pennsylvania Fish and Boat
Commission
1601 Elmerton Ave.
Harrisburg, PA 17110

Mr. Carl Goshorn
Manager, Cumberland County
Conservation District
310 Allen Road
Carlisle, PA 17013

Pennsylvania Game Commission
2001 Elmerton Ave.
Harrisburg, PA 17110-9797

Office of Chief Counsel, Real
Property Division
Pennsylvania Department of
Transportation
Commonwealth Keystone Building
400 North Street, 9th Floor
Harrisburg, PA 17120

US Fish and Wildlife Service
Pennsylvania Field Office
110 Radnor Road, Suite 101
State College, PA 16801-4850

Mr. Rick Reighard
Chair, Supervisor
520 Park Drive
Boiling Springs, PA 17007

Ms. Shelly Capozzi
Vice Chair, Supervisor
520 Park Drive
Boiling Springs, PA 17007

Ms. Jean Foschi
Vice Chair, Cumberland County
1 Courthouse Square
Carlisle, PA 17013

Mr. Bryan Gembusia
Supervisor
520 Park Drive
Boiling Springs, PA 17007

Mr. Gary Eichelberger
Secretary, Cumberland County
1 Courthouse Square
Carlisle, PA 17013

Mr. Ron Hamilton
Supervisor
520 Park Drive
Boiling Springs, PA 17007

Mountain Power LLC
Suite 2000
1360 Post Oak Boulevard
Houston, TX 77056

Ms. Kelly Neiderer
Chairman, Cumberland County
1 Courthouse Square
Carlisle, PA 17013

Date: February 27, 2026



Garrett P. Lent

**BEFORE THE
PENNSYLVANIA PUBLIC UTILITY COMMISSION**

LETTER OF NOTIFICATION OF :
MID-ATLANTIC INTERSTATE :
TRANSMISSION, LLC FOR :
APPROVAL OF THE 115 KILOVOLT :
TRANSMISSION LINE : **Docket No.** _____
RELOCATIONS TO MOUNTAIN :
SUBSTATION PROJECT IN SOUTH :
MIDDLETON TOWNSHIP, :
CUMBERLAND COUNTY, :
PENNSYLVANIA :

LETTER OF NOTIFICATION

TO THE PENNSYLVANIA PUBLIC UTILITY COMMISSION:

Pursuant to 52 Pa. Code § 57.72(d)(1)(i) and (vi), Mid-Atlantic Interstate Transmission, LLC (“MAIT”) hereby files this Letter of Notification requesting approval from the Pennsylvania Public Utility Commission (“Commission”) for the 115 kilovolt (“kV”) Transmission Line Relocations to Mountain Substation Project (“115 kV Transmission Line Relocations to Mountain Substation Project” or “Project”) in South Middleton Township, Cumberland County, Pennsylvania.

The Project was developed as a supplemental project through the PJM Interconnection, LLC (“PJM”) Open Access Transmission Tariff (“OATT”) Attachment M-3 process. The Project is designed to address transmission system needs by reconfiguring and upgrading the 115 kV straight bus portion of the Mountain Substation to a more reliable and resilient ring bus configuration, which will improve the reliability and operational flexibility of the transmission system in the area. In addition to reconfiguring the Mountain Substation to a ring bus configuration, the Project will replace existing circuit breakers and re-terminate three existing 115

kV transmission lines into new bay locations within the Mountain Substation. The transmission line relocations include: (1) replacing approximately 460 feet (0.09 mile) of conductor and shield wire to re-terminate the existing MAIT-owned Gardners-Mountain 115 kV Transmission Line; (2) reusing approximately 177 feet (.03 mile) and 177 total feet (.03 mile) of shield wire to re-terminate the existing NRG Energy, Inc. (“NRG”)-owned NRG Mountain-Mountain CT 115 kV Transmission Line¹; and (3) reusing approximately 379 feet (.1 mile) of conductor and 379 feet (.1 mile) of shield wire to re-terminate the existing MAIT-owned Mountain-PPGI 115 kV Transmission Line.

Completing the Project will: (i) reduce the number of area-wide power disruptions to residential and commercial customers due to transmission bus outages; (ii) improve the reliability of the transmission network and the local distribution system by upgrading the substation with a redundant bus and protection scheme; (iii) eliminate the simultaneous outages of multiple transmission facilities in the area; and (iv) prevent the loss of generation due to simultaneous loss of multiple network facilities.

The Project will be constructed in South Middleton Township, Cumberland County, Pennsylvania. MAIT has provided information regarding this Project to all identified political subdivisions, and none of them have objected to the Project. Subject to the Commission’s approval, construction on the Project is scheduled to begin on or about April 27, 2026, to meet an in-service date of December 31, 2026. To support this construction timeline, MAIT respectfully requests that the Commission issue its final ruling by March 26, 2026.

In support thereof, MAIT submits as follows:

¹ The Company has received conformation and approval from NRG regarding the proposed Project.

I. INTRODUCTION

1. MAIT is a public utility subject to the jurisdiction of the Commission over the siting and construction of transmission lines pursuant to Chapter 57, Subchapter G, of the Commission's regulations.

2. The address of MAIT's principal business office is:

Mid-Atlantic Interstate Transmission, LLC
341 White Pond Drive
Akron, OH 44320

3. The attorneys representing MAIT in this matter authorized to receive notices and communications on its behalf are:

Tori L. Giesler (ID #207742)
FirstEnergy Service Company
341 White Pond Dr.
Akron, OH 44320
(610) 921-6658
tgiesler@firstenergycorp.com

David B. MacGregor (ID #28804)
Garrett P. Lent (ID #321566)
Megan Rulli (ID # 331981)
Post & Schell, P.C.
17 North Second Street
12th Floor
Harrisburg, PA 17101-1601
(717) 731-1970
dmacgregor@postschell.com
glent@postschell.com
mrulli@postschell.com

MAIT agrees to accept electronic service in this proceeding.

4. MAIT also requests that a copy of all notices and communications regarding this matter be sent to:

Thomas Ladson
Transmission Siting Specialist
FirstEnergy Service Company
10802 Bower Avenue
Williamsport, MD 21795
trladson@firstenergycorp.com

5. MAIT provides the following attached Exhibits in support of this Letter of Notification:

- **Exhibit 1:** A depiction of the general location of the Project on a topographic map;
- **Exhibit 2:** A depiction of the general layout of the Project;
- **Exhibit 3:** A depiction of a 115 kV single circuit wood pole equivalent steel horizontal post delta single pole angle structure;
- **Exhibit 4:** A depiction of a 115 kV single circuit steel pole suspension vertical single pole angle structure;
- **Exhibit 5:** A copy of the PJM Subregional Regional Transmission Expansion Plan (“RTEP”) Committee meeting slides dated November 16, 2023, and August 15, 2024;
- **Exhibit 6:** A **CONFIDENTIAL CRITICAL ENERGY INFRASTRUCTURE INFORMATION (“CEII”)** depiction of the existing Mountain Substation configuration;
- **Exhibit 7:** A **CONFIDENTIAL CEII** depiction of the proposed Mountain Substation configuration;
- **Exhibit 8:** A copy of the Wetland Delineation Report prepared by GAI Consultants, Inc (“GAI”), dated April 19, 2024;
- **Exhibit 9:** A copy of the Pennsylvania Natural Diversity Inventory (“PNDI”) receipt dated October 31, 2024;
- **Exhibit 10:** A copy of the response letter from the Pennsylvania Fish and Boat Commission (“PFBC”), dated February 26, 2025; and
- **Exhibit 11:** A copy of the response letter from the Pennsylvania State Historic Preservation Office (“SHPO”), dated January 29, 2025.

- **Exhibit 12:** A list of entities or landowners impacted or potentially impacted by this Project.

6. This Letter of Notification and accompanying Exhibits, which are incorporated herein by reference, contain all the information required by 52 Pa. Code § 57.72(d)(4).

II. THE PROJECT

A. NEED FOR THE PROJECT

7. As explained in more detail below, the proposed Project was developed as a supplemental project that through the PJM OATT Attachment M-3 process for supplemental projects. The Project is needed to: (i) reduce the number of area-wide power disruptions to residential and commercial customers due to transmission bus outages; (ii) improve the reliability of the transmission network and the local distribution system by upgrading the substation with a redundant bus and protection scheme; (iii) eliminate the simultaneous outages of multiple transmission facilities in the area; and (iv) prevent the loss of generation due to simultaneous loss of multiple network facilities. The proposed Project is designed to address these transmission system needs.

1. Existing System

8. The Mountain 115-13.2 kV Substation is located in Cumberland County. It serves as the transmission and distribution power hub for Cumberland County and the surrounding Adams, Lebanon, and York counties. As a distribution hub, the 13.2 kV power from the Mountain Substation directly serves approximately 33 megawatts (“MW”) of load and supplies six FirstEnergy Pennsylvania Electric Company (“FE PA”) distribution circuits in parts of Adams, Cumberland, Lebanon, and York counties. The 13.2 kV portion of the substation directly serves

a total of approximately 7,331 Met-Ed region² customers. The critical customers served from Mountain Substation include one health support facility, eight residences with life support systems, and thirteen major commercial facilities – for a total of 22 critical customers.

9. The 115 kV portion of the Mountain Substation is presently constructed in a straight bus configuration with two 115 kV buses connected by a bus tie switch, as shown in **Exhibit 6 (CEII)**. Each 115 kV bus is connected to one transmission source and one 115-13.2 kV transformer. The two 115-13.2 kV transformers serve two 13.2 kV buses connected by a normally open bus tie breaker. The two 115 kV transmission sources into Mountain Substation are the existing MAIT-owned Mountain-PPGI 115 kV and Gardners-Mountain 115 kV Transmission Lines. Bus 1 also contains an additional connection for the NRG-owned NRG Mountain-Mountain CT 115 kV Transmission Line, which connects to the Mountain NRG generation plant.

10. The existing Gardners-Mountain 115 kV Transmission Line currently utilizes 336.4 26/7 kcmil aluminum conductor steel reinforced (“ACSR”) (LINNET) with 3/8” extra high strength (“EHS”) steel shield wire. The Gardners-Mountain 115 kV Transmission Line re-termination will utilize new conductor and shield wire to match the existing types between structure #130_131_132 and the Mountain Substation. The Mountain-PPGI 115 kV Transmission Line re-termination will reuse the existing 336.4 kcmil 26/7 ACSR with 3/8” EHS steel shield wire to re-terminate the line into the new bay location in the Mountain Substation. Similarly, the NRG-owned NRG Mountain-Mountain CT 115 kV Transmission Line re-termination will reuse the existing 336.4 kcmil 26/7 ACSR with 3/8” EHS steel shield wire to re-terminate into the new bay

² On December 7, 2023, the Commission approved, among other things, the merger of FirstEnergy’s Pennsylvania operating companies, including Metropolitan Edison Company (“Met-Ed”), into FE PA. The merger transaction closed January 1, 2024. FE PA is now the successor in interest to Met-Ed. For this filing, all reference to property/and or assets owned by FE PA, unless stated otherwise, mean property and/or assets located in the rate district of former Met-Ed. For continuity with the merger transaction, the service territory previously served by Met-Ed will be referred to as the “Met-Ed region” for purposes of this filing.

location in the Mountain Substation.

11. The three existing 115 kV transmission lines connected to Mountain Substation are currently supported by one single circuit wood pole deadend structure (existing structure #130_131_132), one single circuit wood pole tangent structure (existing structure #133-134), and one single circuit wood pole deadend structure (existing structure #1), which range from approximately 60 to 70 feet in height. The three existing 115 kV transmission lines connected to Mountain Substation are a mix of vertical and horizontal configurations.

12. A map of the existing system configuration is provided as part of **Exhibit 2**.

2. Identification of Need

13. The Project includes the replacement of the 115 kV portion of the Mountain Substation, which is currently configured as a straight bus scheme where multiple elements are connected to a common bus. The Project will expand the existing substation fence to reconfigure and upgrade the 115 kV bus to a more reliable and resilient ring bus configuration. The Project also includes re-terminating the three 115 kV transmission lines identified above into the newly reconfigured substation.

14. The Project was developed pursuant to the PJM OATT Attachment M-3 process for supplemental projects. As required by the Attachment M-3 process, the need for the proposed substation upgrade project was presented at the PJM Subregional RTEP Committee - Mid-Atlantic meeting on November 16, 2023, and the solution was presented on August 15, 2024. Upon completion of the Attachment M-3 process, PJM assigned the Upgrade ID numbers s3605.1 and s3605.2. Copies of the relevant PJM slides are included as **Exhibit 5** to this Letter of Notification.

15. PJM, a Regional Transmission Organization (“RTO”), is responsible for ensuring the reliability of the electric transmission system under its functional control and coordinating the

movement of wholesale electricity in all or parts of thirteen states and the District of Columbia, including Pennsylvania. PJM is responsible for assuring compliance with North American Electric Reliability Corporation (“NERC”) standards for the bulk electric system within its control area. NERC reliability standards, mandated by the Federal Energy Regulatory Commission, require that the bulk electric system be designed to operate within the applicable thermal and voltage criteria limits, defined in FirstEnergy’s and PJM’s Transmission Planning Criteria, under various system loading conditions and in consideration of credible outages of elements on the bulk electric system

16. PJM, in its capacity as the regional Planning Coordinator, the Transmission Planner and the Transmission Operator, identifies the need and timing for the mandatory transmission system upgrades as part of the reliability planning, economic planning, and interconnection planning processes, to preserve the reliability of the electricity grid that is under its operational control as the RTO. The PJM planning process is an 18-month cycle starting in September of every calendar year. The process ultimately produces a PJM-approved RTEP 18 months later (February). The RTEP identifies transmission system upgrades and enhancements to provide for the operational, economic, and reliability requirements of PJM. The RTEP consists of system upgrades produced from one or more of four planning processes: reliability planning; economic planning; interconnection planning; and local planning.

17. Supplemental upgrades are Transmission Owner (“TO”) initiated projects and are part of the local planning process. In accordance with the Attachment M-3 of the OATT, the TO provides the information regarding the criteria used to plan and identify the supplemental projects at an Assumptions Meeting. The process for developing supplemental projects requires the identification of the system need at a meeting of the PJM Subregional RTEP Committee, which provides an opportunity for industry stakeholders to comment on the project. Next, there is a

solution meeting where the solution to the previously identified need is presented, as well as any alternatives that were considered. The stakeholders again can provide comments to the TO on the solution presented.

18. MAIT supplemental upgrades typically consist of: (i) requests for electric service from new or existing customers; and/or (ii) projects identified pursuant to MAIT's Reliability Enhancement methodology. This methodology and any identified projects are presented to PJM and industry stakeholders in accordance with the PJM OATT Attachment M-3, as described above. Supplemental projects in the Met-Ed transmission zone, like this Project, are in the PJM Mid-Atlantic Subregion, and are presented at the PJM Subregional RTEP Committee – Mid-Atlantic meetings, which occur monthly. Supplemental upgrade projects that have been reviewed through the Attachment M-3 process are identified with an "s" followed by a four-digit number. Supplemental upgrades are not mandated or directed by PJM but are necessary to address planning functions not transferred to PJM (*e.g.*, asset management and customer interconnections). These projects reflect the TO's obligation to reliably serve its local service territory and are grounded in good utility practice.

19. In general, MAIT's Reliability Enhancement methodology is intended to: (i) proactively upgrade or replace transmission lines and substation components that present an increasing risk to reliability; (ii) modernize the transmission infrastructure by implementing technological advances to enhance reliability and promote increased efficiencies; (iii) increase or restore load serving capability; (iv) improve the resiliency of the existing transmission system to better withstand and recover from storms and unusual weather events such as extreme heat and cold; (v) address heightened concerns with cyber and physical security; (vi) improve customer reliability by installing new equipment with real-time monitoring capabilities to optimize

maintenance intervals and reduce the likelihood of equipment failure; and (vii) better address customers' needs by reducing the duration and frequency of unscheduled outages. Reliability Enhancement projects, like this Project, are largely driven by increased reliability needs of customers.

20. The proposed Project eliminates the straight bus configuration that is no longer used for new transmission substations in the MAIT transmission system while improving reliability, resiliency, and operational flexibility for customers served directly from Mountain Substation, as well as other customers served from the 115 kV Transmission Line. The Project is consistent with PJM's General Transmission Owner Guidelines, which are intended to:

- Minimize the magnitude and duration of system outages in the event of a component failure;
- Minimize widespread system effects on voltage, dynamic stability, etc., that occur because of an unplanned event;
- Facilitate the isolation of failed component(s) while maximizing the amount of transmission system equipment that can remain in service; and
- Include plans for expeditious restoration of failed facilities/components (dedicated spare equipment, etc.).

21. FirstEnergy's transmission planning is based on deterministic criteria, and not probabilistic criteria. In other words, FirstEnergy transmission planning assessments result in recommendations to reinforce the transmission system based on an adverse planning event occurring and not based on the probability of the event occurring. FirstEnergy cannot know or predict when a failure or fault will occur but must plan the system for the occurrence.

22. The 115 kV portion of the Mountain Substation is presently constructed in a straight bus configuration. With the existing 115 kV straight bus configuration, a fault on Bus 1 or Transformer 1 would result in an outage of the entire Mountain Substation. A faulted breaker or a breaker failure to open for a transmission line fault would have the same consequences. Similarly, any fault associated with Bus 2 or Transformer 3 would also result in an outage of the Mountain Substation.

23. Further, the existing tie switch between the two 115 kV buses is not able to interrupt a fault from either bus or transformer as the tie switch lacks this capability. An outage of the Mountain Substation would result in the loss of 33 MW serving approximately 7,331 customers.

24. To address these issues, MAIT proposes to build a ring bus configuration at Mountain Substation, as shown in **Exhibit 7 (CEII)**. Construction of the ring bus configuration will significantly reduce the likelihood of a simultaneous outage of multiple facilities at Mountain Substation via a bus fault, transformer fault, or breaker failure condition, which would result in the direct loss of electric service to retail customers, as well as increase reliability and operational flexibility of the transmission system. The proposed ring bus arrangement ensures that no more than two elements would be interrupted due to a breaker failure condition.

25. MAIT reviewed the impact of contingency scenarios on the distribution system's reliability metrics.³ If these contingency scenarios were to take place with the existing transmission system configuration, there would be significant negative impacts to the reliability metrics: System Average Interruption Duration Index ("SAIDI"), System Average Interruption

³ The contingency scenarios used to evaluate the impact on the distribution system's reliability metrics are contingencies that would impact distribution customers directly. That is, any contingency that would cause an interruption of the distribution transformers. In this case, a breaker fault on one of the transmission lines, a bus fault, or a transformer fault would result in an interruption of the entire 115 kV transmission bus at Mountain Substation and interrupt service to the distribution customers served from Mountain Substation.

Frequency Index (“SAIFI”), and Customer Average Interruption Duration Index (“CAIDI”).

26. The negative impacts to the reliability metrics and the Commission’s benchmark for FE PA’s Met-Ed region are summarized in **Table 1** below. This table assumes a three-hour outage duration, which was determined based on historic off-hours outage restoration times necessary to assemble a crew, dispatch the crew to the scene, allow the crew time to determine the issue, and then perform switching to restore customers. **Table 2** below depicts the evaluation of peak loads and customers interrupted both pre and post Project.

Table 1. Impact to reliability metrics.

Reliability Metric	PA PUC Benchmark for Met-Ed region	Outage Impact	Outage Impact on Benchmark
SAIDI	135	2.269	137.3
SAIFI	1.15	0.01261	1.16
CAIDI	117	180	118.1

Table 2. Evaluation of peak load and customers interrupted before and after the proposed Project.

Contingency	Monitored Facility	Before Project		After Project	
		Peak MW Interrupted	Customers Interrupted	Peak MW Interrupted	Customers Interrupted
(1) Fault on Mountain 115 kV bus	Mountain 115 kV Bus	33 (+ 38 MW generator)	7,369	0	0
(2) Fault at Transformer No.1	Mountain 115 – 13.2 kV Transformer No.1	33 (+ 38 MW generator)	7,369	0	0
(3) Fault at Transformer No.2	Mountain 115 – 13.2 kV Transformer No.2	33 (+ 38 MW generator)	7,369	0	0

Contingency	Monitored Facility	Before Project		After Project	
		Peak MW Interrupted	Customers Interrupted	Peak MW Interrupted	Customers Interrupted
(4) Stuck breaker Fault	Mountain 115 kV Bus	33 (+ 38 MW generator)	7,369	0	0
(5) Circuit Switcher Failure/Fault	Mountain 115 kV Capacitor Bank	33 (+ 38 MW generator)	7,369	0	0

27. In the last seven years, there have been 11 unscheduled outages at the Mountain Substation. See **Table 3** below for additional details. The shortest outage time was a few minutes while the longest outage lasted almost 25 hours. The 25-hour outage was due to the failure of AC equipment at the substation, specifically the capacitor bank. The average outage time was 156 minutes, or 2.6 hours. Five of the outages were related to equipment failure, three outages were due to human error, and three outages were due to lightning. In one of the events, a human error caused a 46-minute outage at Mountain Substation that resulted in the interruption to 7,076 customers.

28. Currently configured as a straight bus, any fault event at the station results in the entire substation being out of service until the failed component can be isolated and unaffected portions of the substation restored. Upon conversion to a ring bus, each element of the substation will be configured so that in the event of a fault on an element, only the element impacted will be tripped. The remaining elements connected to the ring bus will be unaffected, continuing to operate. The only exceptions are a stuck breaker condition in which a breaker would fail to operate for a component fault or a faulted breaker condition where a breaker has a component fail such as a bushing or a fault internal to the breaker. In this scenario, the next closest breaker would operate to isolate the failed components. Given the proposed ring design, at a maximum a stuck breaker

would result in two elements out of service at Mountain Substation simultaneously, while the remaining elements connected to the ring bus remain unaffected.

Table 3. Reliability outage history for Mountain Substation

Outage Start	Outage Restored	Duration (Hours)	Outage Type	Cause Category	Cause	Customers Impacted
09/25/2018 9:04:56 AM	09/25/2018 9:51:27 AM	0.78	Unscheduled	Human Error	Human Error - FE Contractor	7,076
09/25/2018 9:04:56 AM	09/25/2018 9:51:27 AM	0.78	Unscheduled	Human Error	Human Error - FE Contractor	0
08/15/2019 9:56:37 PM	08/15/2019 10:00:46 PM	0.07	Unscheduled	Failed AC Substation Equipment	Transformer Failed	0
08/15/2019 9:56:37 PM	08/15/2019 10:01:05 PM	0.07	Unscheduled	Failed AC Substation Equipment	Transformer Failed	0
08/15/2019 9:56:37 PM	08/15/2019 10:02:03 PM	0.09	Unscheduled	Failed AC Substation Equipment	Transformer Failed	0
04/15/2020 10:46:00 AM	04/15/2020 12:00:00 PM	1.23	Unscheduled	Human Error	Relay Design Incorrect (Human Error - Eng)	0
08/18/2021 6:02:00 PM	08/18/2021 6:14:00 PM	0.20	Unscheduled	Lightning	No correlation available	0
08/18/2021 6:02:43 PM	08/18/2021 6:14:09 PM	0.19	Unscheduled	Lightning	No correlation available	0
08/18/2021 6:02:43 PM	08/18/2021 6:14:57 PM	0.20	Unscheduled	Lightning	No correlation available	0
01/13/2024 2:06:39 PM	01/13/2024 2:06:39 PM	0.00	Unscheduled	Failed AC Circuit Equipment	Down Ground	0
08/27/2024 12:57:29 PM	08/28/2024 1:52:00 PM	24.91	Unscheduled	Failed AC Substation Equipment	Cap - Unbalance - Failed Unit	0

B. THE PROPOSED PROJECT

29. For this Project, MAIT proposes to expand the existing substation fence to reconfigure Mountain Substation⁴ to a ring bus configuration. As a result, the existing Gardners-Mountain 115 kV Transmission Line, Mountain-PPGI 115 kV Transmission Line, and NRG-owned NRG Mountain-Mountain CT 115 kV Transmission Line must be re-terminated at three new terminal locations within the substation. Presently, all lines are a single circuit configuration supported by wood pole structures located on existing easements.

30. To facilitate the reconfiguration of Mountain Substation, approximately 460 feet of new conductor and shield wire will be installed from existing structure #130_131_132 of the Gardners-Mountain 115 kV Transmission Line through proposed structure #133_134 into the new southeast terminal at Mountain Substation. Fiber will be installed into the new control house to connect the existing control house within Mountain Substation. The existing angle of termination is approximately 3.90 degrees and the proposed angle of termination is approximately 2.25 degrees.

31. The existing NRG-owned NRG Mountain-Mountain CT 115 kV Transmission Line will utilize existing structure # NRG-1 to connect to the middle eastern terminal at Mountain Substation. The proposed NRG-owned NRG Mountain-Mountain CT 115 kV Transmission Line terminal at Mountain Substation extends approximately 70 feet further east than the existing terminal, thus, existing conductor and shield wire will be utilized. The existing angle of termination is -38.73 degrees and the proposed angle of termination is -40.56 degrees.

⁴ Presently, the Mountain Substation is wholly owned by FE PA. After this Project is complete and the assets placed in service, the Mountain Substation will be a dual MAIT/FE PA substation with MAIT owning the networked transmission assets and FE PA owning distribution assets within the substation yards

32. Similarly, the proposed Mountain-PPGI 115 kV Transmission Line terminal at Mountain Substation will extend approximately 90 feet further northeast than the existing terminal. Existing structure #1 of the Mountain-PPGI 115 kV Transmission Line will be replaced and relocated approximately 30 feet northeast of existing location and the existing conductor and shield wire will be utilized to terminate into the proposed northeast terminal at Mountain Substation. The existing angle of termination is -39.64 degrees and the proposed angle of termination is -45.86 degrees.

33. Existing structure #133_134 of the Gardners-Mountain 115 kV Transmission Line is approximately 60 feet in height, and the proposed new single wood pole equivalent steel structure #133_134 will be approximately 61.5 feet in height and is depicted in **Exhibit 3**. Existing structure #130_131_132 of the Gardners-Mountain 115 kV Transmission Line will be modified by replacing old shield wire and conductor assemblies as well as adding additional down guy wire. Existing structure #1 of the Mountain-PPGI 115 kV Transmission Line is approximately 70 feet in height, and the proposed new steel custom structure #1 will be approximately 66 feet in height and is depicted in **Exhibit 4**.

34. Overall, approximately 460 feet (0.09 mile) of conductor and shield wire will be replaced on the existing Gardners-Mountain 115 kV Transmission Line terminating into Mountain Substation. The existing NRG-owned NRG Mountain-Mountain CT 115 kV Transmission Line conductors and shield wire will be reused from Structure # NRG-1 into the substation for a total conductor distance of approximately 177 feet (.03 mile) and 177 total feet (.03 mile) of shield wire. The existing Mountain-PPGI 115 kV Transmission Line will have existing structure #1 replaced and existing conductors and shield wires utilized for a distance of approximately 379 feet (.1 mile) of conductor and 379 feet (.1 mile) of shield wire.

35. The proposed Project will modify the Mountain Substation to meet the current minimum FirstEnergy design standard for new substations and mitigate the contingency scenarios discussed. The minimum FirstEnergy requirements for new transmission substations are either a “breaker-and-a-half” configuration or a “ring bus” configuration, as documented in FirstEnergy’s “Requirements for Transmission Connected Facilities” document. Three types of breaker configurations were considered when planning the upgrade to the Mountain Substation – the “double-breaker” configuration, the “breaker-and-a-half” configuration, and the “ring bus” configuration. All the considered alternatives meet the requirements outlined in FirstEnergy’s “Requirements for Transmission Connected Facilities” document.

36. The double-breaker configuration would be the most reliable substation configuration since it provides full redundancy for every terminal (i.e., two breakers per substation element/terminal). The double-breaker configuration is also the most expensive option as it would require the greatest number of circuit breakers –12 breakers would be required for the six transmission elements (two transformers, one capacitor bank, and three transmission lines). As such, the double-breaker configuration was not selected.

37. The breaker-and-a-half configuration was also considered; however, this configuration was not required due to the number of elements connected to the substation bus. Presently, there are three 115 kV transmission lines that terminate at the substation, two distribution transformers, and one capacitor bank for a total of six connected elements. The preferred maximum number of elements in a ring bus configuration for a FirstEnergy substation is six. If the number of ring bus elements was greater or is expected to exceed the maximum number of allowable attachments to a ring bus, then a breaker-and-a-half configuration would have been the preferred substation configuration. Since there are no future elements presently

anticipated to connect to the Mountain Substation, and there are only six existing elements connected, the preferred solution is to design the substation in a ring bus configuration. The ring bus configuration is the least expensive alternative considered and meets FirstEnergy's minimum substation design requirements.

38. FirstEnergy's Engineering resources evaluated the layout of the existing Mountain Substation and determined that constructing a new 115 kV ring bus at the existing substation location would be feasible. After the Project is completed, Mountain Substation will include a new 115 kV yard with the ring bus, the current substation with the 115-13.2 kV transformers, and the 13.2 kV switchyard. This will be similar to the current layout of the substation as the new 115 kV yard will simply replace the existing 115 kV yard. The 13.2 kV distribution substation equipment will remain as-is and two short 115 kV tie lines will connect the new 115 kV assets to the two existing 115-13.2 kV transformers, all within the same fenced footprint.

39. Upgrading the 115 kV bus in the existing substation from the existing straight bus scheme to a more robust ring bus scheme will provide redundancy, eliminate the single contingency risk associated with the 115 kV bus, breaker, or transformer failures, and reduce the risk of a complete transmission outage to the transmission support at Mountain Substation. Note that the proposed substation project is not needed to address a NERC, PJM, or FirstEnergy Planning Criteria violation and is not part of a larger project. The Project is a supplemental project driven by the FirstEnergy Reliability Enhancement methodology based on the existing system configuration and its impact on the reliability of electric service to the residents and businesses of the area.

40. With the upgrade of the 115 kV bus, MAIT did not consider the use of any advanced technologies since the majority of the work will be completed within the existing Mountain

Substation. Examples of advanced technologies that MAIT considers while proposing reliability projects include the use of Dynamic Line Rating technologies and/or the use of advanced conductors. Dynamic Line Rating technologies use software and hardware to determine the thermal limits of a transmission line in real time based on rating methodologies and ambient conditions within a given area which can either increase or decrease the thermal ratings of the transmission line. Advanced conductors are a class of conductors that can operate at higher temperatures, may use composite (i.e., non-steel) cores, and have a lower resistance than conventional transmission line conductors. These advanced conductors allow for increased capacity on a given transmission line due to the reduced sagging of the transmission line at higher temperatures. These advanced technologies were not considered since the transmission line work that is part of this Letter of Notification is ancillary to the substation project.

41. The Project will make the power system in the area more resilient and reliable. The new ring bus configuration at Mountain Substation will greatly reduce the potential for outages in the area.

42. A depiction of the general location of the Project is available in **Exhibit 1**. A depiction of the general layout for the Project is available in **Exhibit 2**.

43. If approved, pre-outage construction of the 115 kV Transmission Line Relocations to Mountain Substation Project is anticipated to begin on or about March 2, 2026, and planned to be placed in service by December 31, 2026.

44. The estimated total cost for the proposed transmission line facilities is approximately \$1,415,000.⁵ This cost includes approximately \$343,000 for engineering, \$89,000 for materials, and \$983,000 for construction. The cost of the Project will be paid for by MAIT.

⁵ The cost associated with upgrading the Mountain Substation, which is not part of this filing, is approximately \$22,000,000.

MAIT owns the Mountain-PPGI 115 kV and Gardners-Mountain 115 kV Transmission Lines. The NRG Mountain-Mountain CT 115 kV Transmission Line is owned by NRG. The point of interconnection (“POI”) between MAIT and NRG is located within the substation. MAIT will perform the transmission line relocation for the NRG-owned line as the sponsor for the overall Project.

III. HEALTH AND SAFETY

45. The proposed Project will not create any unreasonable risk of danger to public health or safety. The Project will be designed to meet or exceed all requirements of the latest revision of the National Electrical Safety Code (“NESC”) under all operating conditions as well as FirstEnergy’s current design criteria.

46. FirstEnergy’s design criteria require that 115 kV transmission lines have a designed vertical conductor-to-ground clearance of 26 feet. This design value exceeds the NESC minimum of 20.2 feet by a margin of 5.8 feet. In general, FirstEnergy’s clearance criteria exceed the NESC minimums by various margins ranging from two feet to seven feet, depending on the voltage and specific clearance measurement. The transmission line’s maximum operating temperature will be 212 degrees Fahrenheit.

47. The design, construction, and operation of the Project will meet or exceed all applicable safety standards established by the Occupational Safety and Health Administration (“OSHA”). Moreover, the Project will be constructed in accordance with the Company’s standard construction practices to perform all work safely. All work will be performed in keeping with NESC, OSHA, and all other applicable state and federal requirements.

IV. DESCRIPTION OF THE RIGHT-OF-WAY

48. The Project will utilize existing right-of-way (“ROW”) that is 200 feet wide. The

existing transmission centerline is offset by approximately 50 feet from the edge of the 200-foot-wide ROW, as shown on **Exhibit 2**. Proposed structures will generally be located in the same location as existing structures along the centerline.

49. The Project is being executed by MAIT, a FirstEnergy company which owns transmission assets and provides transmission service in Pennsylvania. Presently, all lines are a single circuit configuration supported by wood pole structures located on existing ROW.

V. LAND USE AND ENVIRONMENTAL EVALUATION

50. As explained above, construction of the proposed Project will take place entirely within the existing ROW. Therefore, it is anticipated that the proposed Project will have minimal incremental impacts on land use in the area.

51. A Wetland and Watercourse Delineation Report for the Project area was conducted by GAI in April 2024 and a copy of the Field Report Memo dated April 19, 2024 is included as **Exhibit 8**. No streams or wetlands were identified in the Project area during the field review. It is anticipated that no Pennsylvania Department of Environmental Protection (“PA DEP”) Chapter 105 permitting will be required for the proposed substation upgrades due to the lack of water resources on site.

52. The proposed limit of disturbance (“LOD”) for the Project is anticipated to be under one acre, but greater than 5,000 square feet. Since the project LOD is anticipated to be greater than 5,000-square feet, a Site-Specific Erosion and Sediment Control Plan was prepared and submitted to Cumberland County Conservation District for review to meet PA DEP Chapter 102 provisions.

53. A PNDI search was conducted on October 31, 2024, for the proposed Project area and is enclosed as **Exhibit 9**. The Pennsylvania Department of Conservation and Natural

Resources, Pennsylvania Game Commission, and U.S. Fish and Wildlife Service indicated no known impacts to threatened and endangered species and/or special concern species and resources within the Project area. The PFBC indicated a potential impact to the Eastern Spade-foot toad (*Scaphiopus holbrookii*), which is listed as threatened. A habitat assessment was conducted in Fall of 2024. During the survey, potential Eastern Spade-foot toad habitat was identified. These findings were submitted to the PFBC in January 2025 for review and comment. PFBC conducted a site visit on February 24, 2025, and confirmed the presence of potential habitat. On February 26, 2025, the PFBC issued a Species Impact Review Letter, which is enclosed as **Exhibit 10**, confirming that the site contains potential habitats for the Eastern Spade-foot toad, that the proposed Project activities will not directly impact any seasonal pool, and that proposed construction activities are contained to degraded portions of habitat under the existing electrical lines. Given the nearby occurrences of the species, PFBC recommend the following avoidance and minimization measures:

- Earth moving and disturbance should be limited to the inactive season of the Eastern Spade-foot toad (November 15 – April 15).
- If earth moving and disturbance occur during the active season, then Eastern Spadefoot toads should be removed from the area by a qualified surveyor. Following clearance of the area a silt fence should be installed and strict erosion and sediment control plan implemented.

MAIT has reviewed recommendations provided by the PFBC and will adhere to the above provisions.

54. Consultation with the SHPO was initiated on January 17, 2025, and SHPO response was received January 29, 2025. The response indicated no effect to above ground resources and no effect to archeological resources. The response letter from SHPO is included as **Exhibit 11**.

55. No tree clearing is anticipated for the Project. MAIT will implement appropriate measures during construction, and throughout the subsequent operation of the Project, to avoid or minimize potential impacts to environmental resources. MAIT will obtain the applicable state and federal permits and approvals needed to construct the Project. An erosion and sediment control plan will be submitted to the Cumberland County Conservation District for approval. Best management practices for soil erosion and sediment control will be put in place prior to any earth disturbance.

VI. NOTICE

56. MAIT has provided information regarding the Project to representatives of South Middleton Township, the Cumberland County Conservation District, and the Cumberland County Planning Commission. These entities have not objected to the proposed Project. Copies of the Letter of Notification will be served upon all state agencies, federal agencies, county agencies, municipalities, and landowners in accordance with 52 Pa. Code § 57.72(d)(3). A list of the same entities or landowners impacted or potentially impacted by this Project is provided in **Exhibit 12**.

VII. LETTER OF NOTIFICATION

57. MAIT is proceeding by means of a Letter of Notification, instead of a full Application, pursuant to the Commission's regulations at 52 Pa. Code § 57.72(d)(1)(i) and (d)(1)(vi).

58. The Project involves the removal and replacement of two existing structures, modification of one existing structure, installation of approximately 460 feet of conductor and

shield wire, and reuse of approximately 1,668 feet (.32 mile) of conductor and 556 feet (.11 mile) of shield wire, located in South Middleton Township, Cumberland County, Pennsylvania. In addition, the Project will utilize existing 200-foot-wide ROW, and the proposed structures will generally be located in the same location as existing structures along the centerline of the existing ROW. As such, the Project meets the parameters of 52 Pa. Code § 57.72(d)(1)(i) of the Commission's regulations because the Project is proposed to be located on an existing transmission line ROW and will not substantially alter the existing transmission line ROW. *See* 52 Pa. Code § 57.72(d)(1)(i). The Project also meets the parameters of Pa. Code § 57.72(d)(1)(vi) because the total line length of the re-terminated transmission lines is less than 2 miles. *See* 52 Pa. Code § 57.72(d)(1)(vi).

59. This Letter of Notification is filed on the date set forth below. As provided in 52 Pa. Code § 57.72(d)(5), the Commission will review and, by order, approve or disapprove this Letter of Notification. If the Commission approves this Letter of Notification, the proposed Project will be constructed as proposed herein without the formal application process set forth at 52 Pa. Code §§ 57.71, *et seq.*

WHEREFORE, Mid-Atlantic Interstate Transmission, LLC respectfully requests that the Commission review and approve the proposed 115 kV Transmission Line Relocations to Mountain Substation Project located in South Middleton Township, Cumberland County, Pennsylvania, that is explained above and in the Exhibits attached hereto, on or before March 26, 2026.



Tori L. Giesler (ID #207742)
FirstEnergy Service Company
341 White Pond Drive
Akron, OH 44320
Phone: (717) 490-3292
Email: tgiesler@firstenergycorp.com

David B. MacGregor (ID #28804)
Garrett P. Lent (ID #321566)
Megan E. Rulli (ID # 331981)
Post & Schell, P.C.
17 North Second Street
12th Floor
Harrisburg, PA 17101-1601
Phone: (717) 731-1970
Fax: (717) 731-1985
E-mail: dmacgregor@postschell.com
E-mail: glent@postschell.com
Email: mrulli@postschell.com

Date: February 27, 2026

Attorneys for Mid-Atlantic Interstate
Transmission, LLC

Exhibit 1



SOUTH MIDDLETON TWP
CUMBERLAND COUNTY
PENNSYLVANIA

LEGEND:

- ★ Mountain Substation
- ▲ MAIT Substation
- ▲ Foreign Substation
- 115 kV Transmission Line
- Foreign 115 kV Transmission Line

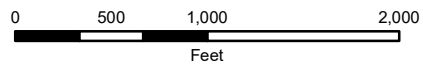

Reference:

USGS Topographical Overlay

Coordinate System:

NAD 1983 StatePlane Pennsylvania South FIPS 3702 Feet
Projection - Conformal Conic; Units - US Feet

KEY MAP - NOT TO SCALE

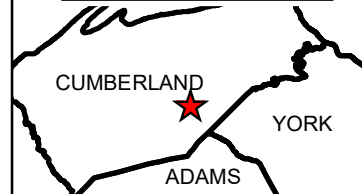

EXHIBIT 1



**115 kV Transmission Line Relocations
To Mountain Substation Project**

Exhibit 2

PAPER SIZE: 11X17

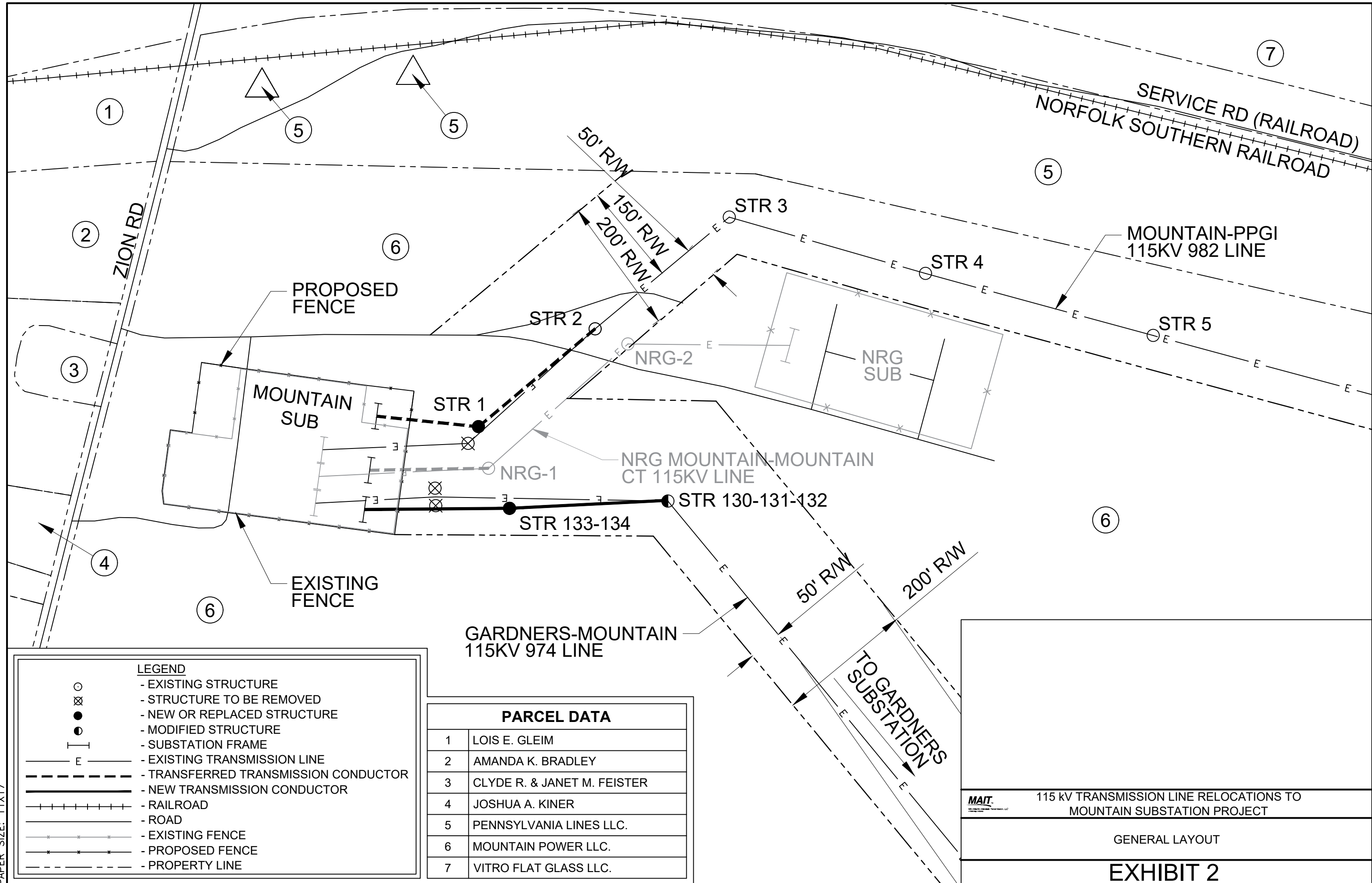

LEGEND

- - EXISTING STRUCTURE
- ⊗ - STRUCTURE TO BE REMOVED
- - NEW OR REPLACED STRUCTURE
- ◐ - MODIFIED STRUCTURE
- - SUBSTATION FRAME
- E — - EXISTING TRANSMISSION LINE
- - - - - TRANSFERRED TRANSMISSION CONDUCTOR
- — — — — NEW TRANSMISSION CONDUCTOR
- +++++ - RAILROAD
- — — — — ROAD
- * - * - EXISTING FENCE
- * - * - PROPOSED FENCE
- - - - - PROPERTY LINE

PARCEL DATA	
1	LOIS E. GLEIM
2	AMANDA K. BRADLEY
3	CLYDE R. & JANET M. FEISTER
4	JOSHUA A. KINER
5	PENNSYLVANIA LINES LLC.
6	MOUNTAIN POWER LLC.
7	VITRO FLAT GLASS LLC.

MAIT 115 kV TRANSMISSION LINE RELOCATIONS TO MOUNTAIN SUBSTATION PROJECT

GENERAL LAYOUT

EXHIBIT 2

Exhibit 3

PAPER SIZE: 8.5X11

61'-6"

SCALE: NTS

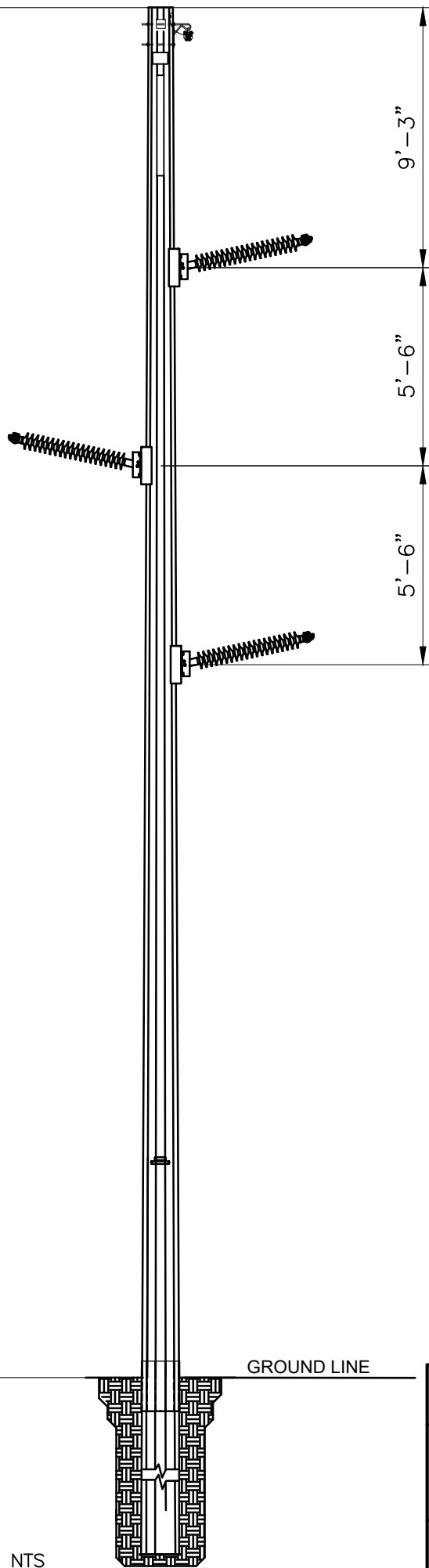

115 kV Transmission Line Relocations To
Mountain Substation Project

115KV SINGLE CIRCUIT WOOD POLE EQUIVALENT
STEEL STRUCTURE HORIZONTAL POST DELTA
SINGLE POLE ANGLES 0° TO 2°

EXHIBIT 3

PRELIMINARY PRINT ONLY
NOT FOR CONSTRUCTION

Exhibit 4

PAPER SIZE: 8.5X11

SCALE: NTS

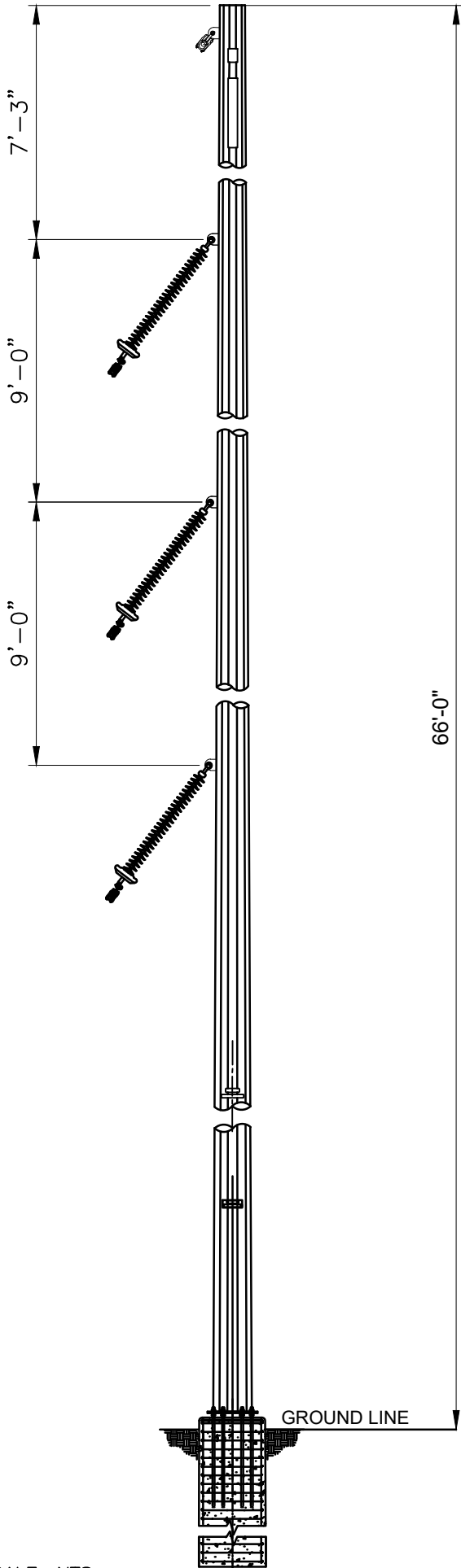

PRELIMINARY PRINT ONLY
 NOT FOR CONSTRUCTION

	115 kV Transmission Line Relocations To Mountain Substation Project
115KV SINGLE CIRCUIT STEEL POLE ON DRILLED PIER SUSPENSION VERTICAL SINGLE POLE ANGLES 30° TO 60°	
EXHIBIT 4	

Exhibit 5

Need Number: ME-2023-017

Process Stage: Solution Meeting – 08/15/2024

Previously Presented: Needs Meeting – 11/16/2023

Project Driver:

Operational Flexibility and Efficiency

Specific Assumption Reference:

System Performance Projects

- Add/Expand Bus Configuration
- Load at risk in planning and operational scenarios
- Reduce the amount of exposed potential local load loss during contingency conditions
- Eliminate simultaneous outages to multiple networked elements

Problem Statement:

Mountain Substation can be outaged from a fault on the 115 kV bus, a fault on the No. 1 or No. 2 115-13.2 kV transformers, a fault on the Mountain CT transformer, or a stuck breaker on the PPGI or Gardners 115 kV line exits. Mountain Substation serves 7,320 customers and approximately 31.8 MW.

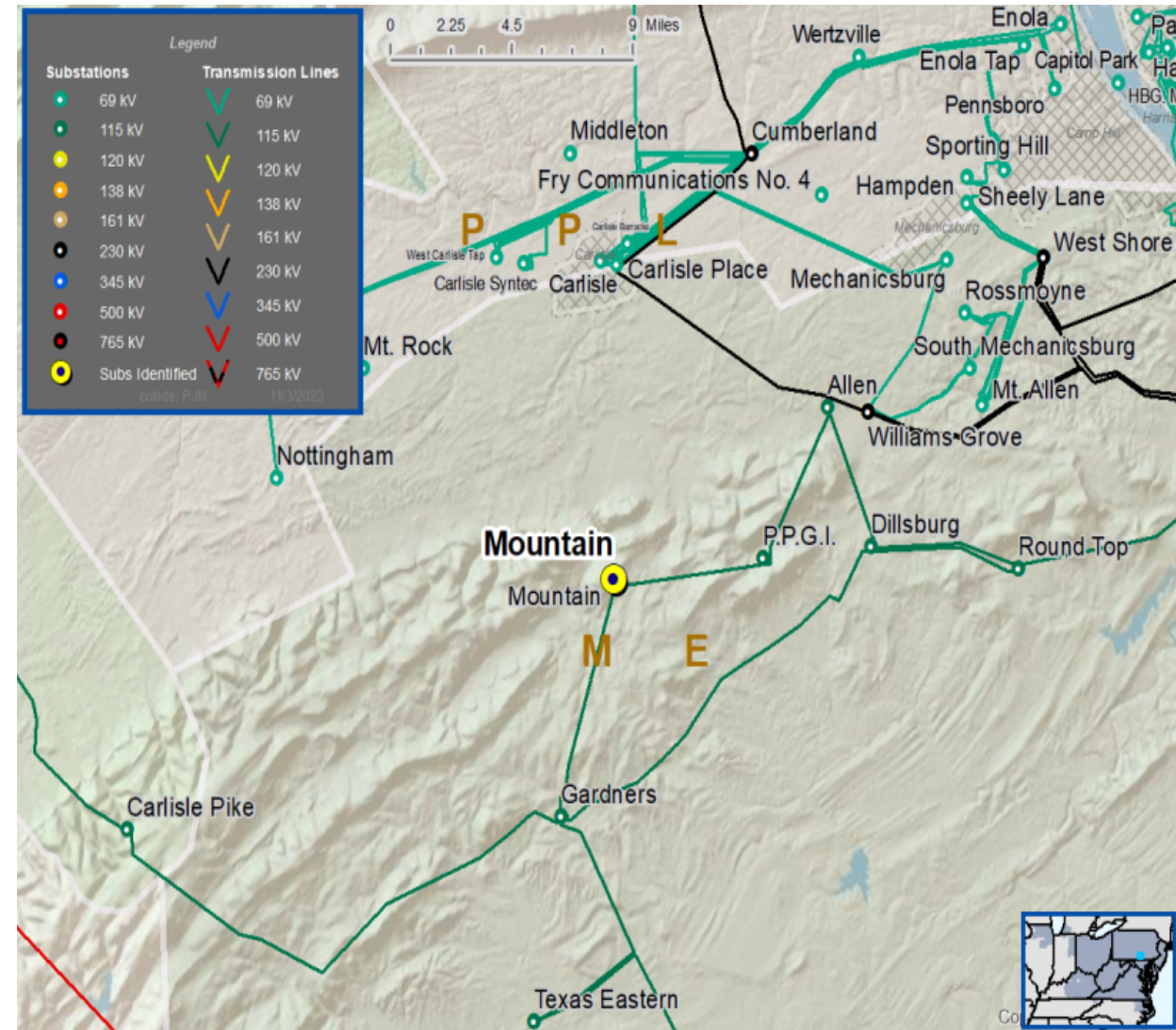

Need Number: ME-2023-017

Process Stage: Solution Meeting – 08/15/2024

Proposed Solution:

- Convert Mountain 115 kV into a six-breaker ring bus
- At PPGI, replace one 115 kV circuit breaker

Alternatives Considered:

Maintain existing condition with reliability risk to customers.

Estimated Project Cost: \$11.4M

Projected In-Service: 12/31/2026

Status: Conceptual

Model: 2023 RTEP model for 2028 Summer (50/50)

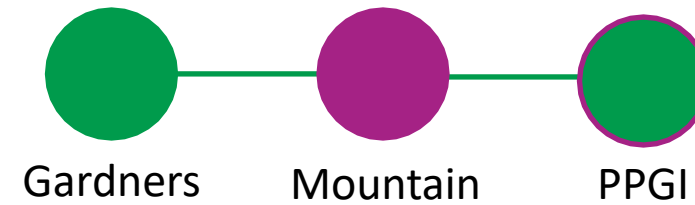

Legend	
500 kV	
345 kV	
230 kV	
138 kV	
115 kV	
69 kV	
46 kV	
34.5 kV	
23 kV	
New	

Exhibit 6

Exhibit 6

Exhibit 6 contains Confidential Security Information for the purposes of the Public Utility Confidential Security Information Act, 35 P.S. § 2141.1-2141.6, and for the purposes of Chapter 102 of the Rules and Regulations of the Pennsylvania Public Utility Commission, 52 Pa. Code § 102.1-102.4, and should be afforded confidential treatment as described in the statute and regulation. This exhibit also contains privileged and confidential information and/or critical infrastructure information (“CEII”). Do not release pursuant to 18 C.F.R. §388.112.

This exhibit has been redacted.

Exhibit 7

Exhibit 7

Exhibit 7 contains Confidential Security Information for the purposes of the Public Utility Confidential Security Information Act, 35 P.S. § 2141.1-2141.6, and for the purposes of Chapter 102 of the Rules and Regulations of the Pennsylvania Public Utility Commission, 52 Pa. Code § 102.1-102.4, and should be afforded confidential treatment as described in the statute and regulation. This exhibit also contains privileged and confidential information and/or critical infrastructure information (“CEII”). Do not release pursuant to 18 C.F.R. §388.112.

This exhibit has been redacted.

Exhibit 8

Field Report Memo

Date:	April 19, 2024
Project No.	R230982.01, Task 001
Project Name:	Mountain Substation Expansion Project, Cumberland County, Pennsylvania

Summary of Events

On April 4th, 2024, GAI Consultants, Inc. (GAI), on behalf of FirstEnergy Corporation, conducted an environmental resource survey for wetlands and streams within a fourteen-acre area surrounding the existing substation for the Mountain Substation Expansion Project (Project) in Cumberland County, Pennsylvania (PA).

Review of existing data indicates the Project area is within the Mountain Creek Hydrologic Unit Code 12 Watershed (020503050503). On-site habitats surrounding the Project study area consists of maintained open grassy areas, disturbed honeysuckle forests, industrial complexes and agricultural fields. The site received several days of heavy rain proceeding the field study. Attachment 1 depicts the Project area on the Feature Overview Map.

Wetland and Stream Field Survey Results

Wetland reviews were conducted according to the 1987 United States Army Corps of Engineers *Wetlands Delineation Manual* and the *Regional Supplement to the Corps of Engineers Wetland Delineation Manual: Eastern Mountains and Piedmont Region* (Version 2.0). Prior to the environmental field review, GAI obtained and reviewed United States Geological Survey topographic mapping, National Wetlands Inventory database, National Hydrography Dataset (NHD), and the United States Department of Agriculture-Natural Resources Conservation Service's soil mapping to supplement the field data. No NHD streams were identified within the project area. One National Wetlands Inventory wetland was indicated within the Project area and was analyzed at STP-BJY-003.

No wetlands were identified during the environmental resource survey.

No streams were identified during the environmental resource survey.

Three soil test pits were dug and characterized to rule out possible wetland areas. Field indicators for hydrology, hydrophytic vegetation and hydric soil were not present at the time of the survey.

The results of the wetland and stream survey are displayed on the Feature Overview Map in Attachment 1, and representative photographs of the soil test pits are provided in Attachment 2.

Exhibit 9

1. PROJECT INFORMATION

Project Name: **Mountain Substation**

Date of Review: **10/31/2024 10:43:52 AM**

Project Category: **Energy Storage, Production, and Transfer, Energy Transfer, Power/electric line - New (new location for above/under-ground line)**

Project Area: **14.49 acres**

County(s): **Cumberland**

Township/Municipality(s): **SOUTH MIDDLETON TOWNSHIP**

ZIP Code:

Quadrangle Name(s): **MOUNT HOLLY SPRINGS**

Watersheds HUC 8: **Lower Susquehanna-Swatara**

Watersheds HUC 12: **Mountain Creek**

Decimal Degrees: **40.122639, -77.174837**

Degrees Minutes Seconds: **40° 7' 21.4991" N, 77° 10' 29.4145" W**



2. SEARCH RESULTS

Agency	Results	Response
PA Game Commission	No Known Impact	No Further Review Required
PA Department of Conservation and Natural Resources	No Known Impact	No Further Review Required
PA Fish and Boat Commission	Potential Impact	FURTHER REVIEW IS REQUIRED, See Agency Response
U.S. Fish and Wildlife Service	No Known Impact	No Further Review Required

As summarized above, Pennsylvania Natural Diversity Inventory (PNDI) records indicate there may be potential impacts to threatened and endangered and/or special concern species and resources within the project area. If the response above indicates "No Further Review Required" no additional communication with the respective agency is required. If the response is "Further Review Required" or "See Agency Response," refer to the appropriate agency comments below. Please see the DEP Information Section of this receipt if a PA Department of Environmental Protection Permit is required.

Mountain Substation





-  Buffered Project Boundary
-  Project Boundary

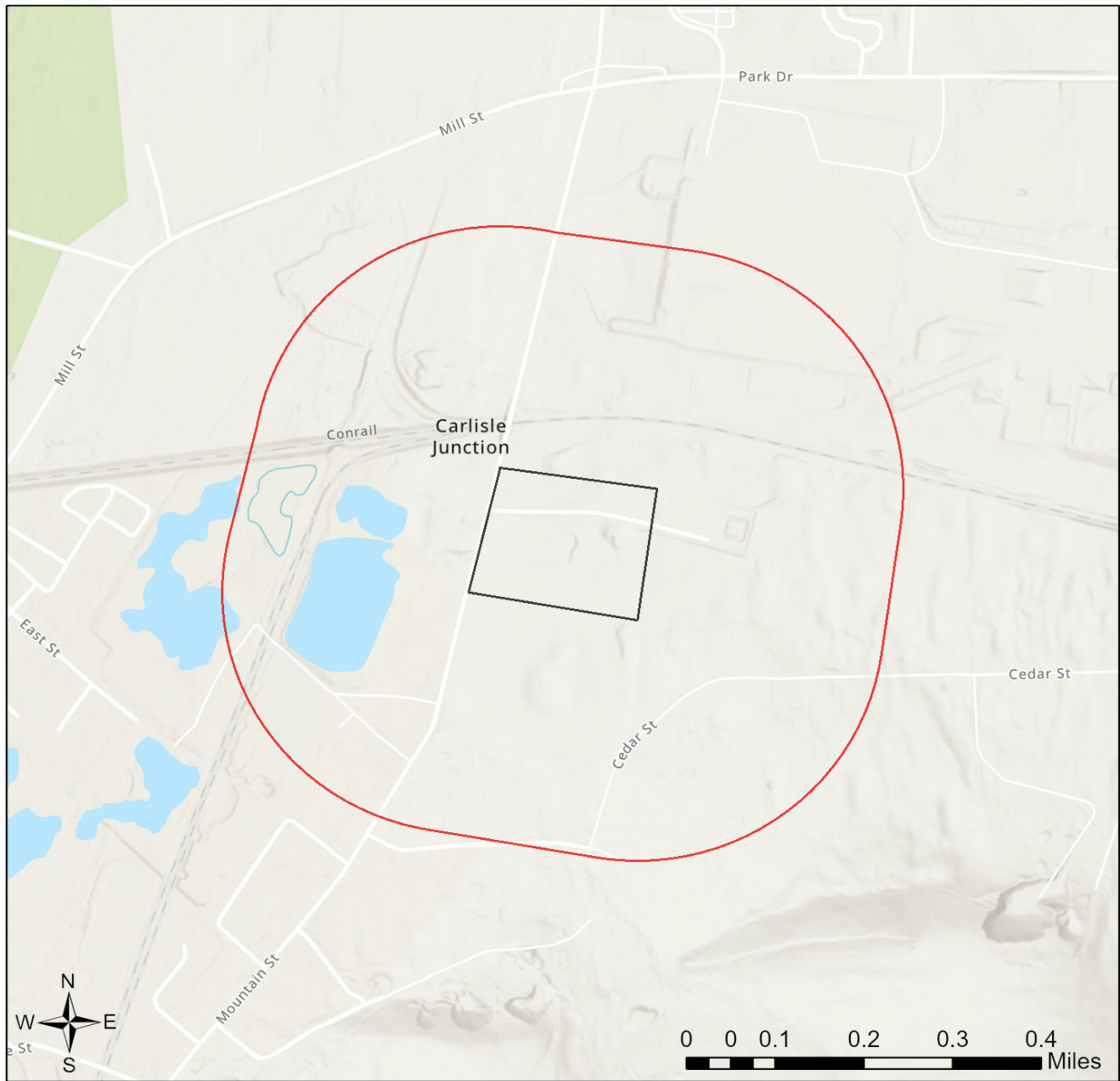

Sources: Esri, Airbus DS, USGS, NGA, NASA, CGIAR, N Robinson, NCEAS, NLS, OS, NMA, Geodatastyrelsen, Rijkswaterstaat, GSA, Geoland, FEMA, Intermap and the GIS user community

Mountain Substation



-  Buffered Project Boundary
-  Project Boundary

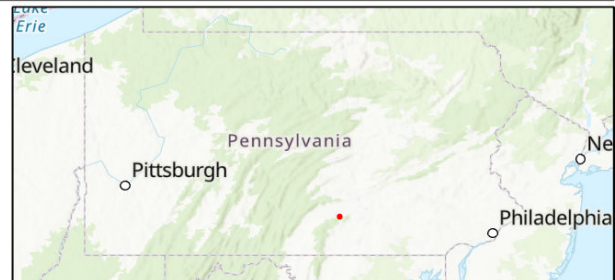

Sources: Esri, Airbus DS, USGS, NGA, NASA, CGIAR, N Robinson, NCEAS, NLS, OS, NMA, Geodatastyrelsen, Rijkswaterstaat, GSA, Geoland, FEMA, Intermap and the GIS user community

RESPONSE TO QUESTION(S) ASKED

Q1: Accurately describe what is known about wetland presence in the project area or on the land parcel by selecting ONE of the following. "Project" includes all features of the project (including buildings, roads, utility lines, outfall and intake structures, wells, stormwater retention/detention basins, parking lots, driveways, lawns, etc.), as well as all associated impacts (e.g., temporary staging areas, work areas, temporary road crossings, areas subject to grading or clearing, etc.). Include all areas that will be permanently or temporarily affected -- either directly or indirectly -- by any type of disturbance (e.g., land clearing, grading, tree removal, flooding, etc.). Land parcel = the lot(s) on which some type of project(s) or activity(s) are proposed to occur.

Your answer is: Someone qualified to identify and delineate wetlands (holding a natural resource degree or equivalent work experience) has investigated the site, and determined that NO wetlands are located in or within 300 feet of the project area. (A written report from the wetland specialist, and detailed project maps should document this.)

Q2: The proposed project is in the range of the Indiana bat. Describe how the project will affect bat habitat (forests, woodlots and trees) and indicate what measures will be taken in consideration of this. Round acreages up to the nearest acre (e.g., 0.2 acres = 1 acre).

Your answer is: The project will affect 1 to 39 acres of forests, woodlots and trees.

Q3: Is tree removal, tree cutting or forest clearing of 40 acres or more necessary to implement all aspects of this project?

Your answer is: No

3. AGENCY COMMENTS

Regardless of whether a DEP permit is necessary for this proposed project, any potential impacts to threatened and endangered species and/or special concern species and resources must be resolved with the appropriate jurisdictional agency. In some cases, a permit or authorization from the jurisdictional agency may be needed if adverse impacts to these species and habitats cannot be avoided.

These agency determinations and responses are **valid for two years** (from the date of the review), and are based on the project information that was provided, including the exact project location; the project type, description, and features; and any responses to questions that were generated during this search. If any of the following change: 1) project location, 2) project size or configuration, 3) project type, or 4) responses to the questions that were asked during the online review, the results of this review are not valid, and the review must be searched again via the PNDI Environmental Review Tool and resubmitted to the jurisdictional agencies. The PNDI tool is a primary screening tool, and a desktop review may reveal more or fewer impacts than what is listed on this PNDI receipt. The jurisdictional agencies **strongly advise against** conducting surveys for the species listed on the receipt prior to consultation with the agencies.

PA Game Commission

RESPONSE:

No Impact is anticipated to threatened and endangered species and/or special concern species and resources.

PA Department of Conservation and Natural Resources

RESPONSE:

No Impact is anticipated to threatened and endangered species and/or special concern species and resources.

PA Fish and Boat Commission

RESPONSE:

Further review of this project is necessary to resolve the potential impact(s). Please send project information to this agency for review (see WHAT TO SEND).

PFBC Species: (Note: The Pennsylvania Conservation Explorer tool is a primary screening tool, and a desktop review may reveal more or fewer species than what is listed below.)

Scientific Name	Common Name	Current Status
Sensitive Species**		Threatened

U.S. Fish and Wildlife Service

RESPONSE:

No impacts to **federally** listed or proposed species are anticipated. Therefore, no further consultation/coordination under the Endangered Species Act (87 Stat. 884, as amended; 16 U.S.C. 1531 et seq. is required. Because no take of federally listed species is anticipated, none is authorized. This response does not reflect potential Fish and Wildlife Service concerns under the Fish and Wildlife Coordination Act or other authorities.

* Special Concern Species or Resource - Plant or animal species classified as rare, tentatively undetermined or candidate as well as other taxa of conservation concern, significant natural communities, special concern populations (plants or animals) and unique geologic features.

** Sensitive Species - Species identified by the jurisdictional agency as collectible, having economic value, or being susceptible to decline as a result of visitation.

WHAT TO SEND TO JURISDICTIONAL AGENCIES

If project information was requested by one or more of the agencies above, upload* or email the following information to the agency(s) (see AGENCY CONTACT INFORMATION). Instructions for uploading project materials can be found [here](#). This option provides the applicant with the convenience of sending project materials to a single location accessible to all three state agencies (but not USFWS).

*If information was requested by USFWS, applicants must email, or mail, project information to IR1_ESPenn@fws.gov to initiate a review. USFWS will not accept uploaded project materials.

Check-list of Minimum Materials to be submitted:

___ Project narrative with a description of the overall project, the work to be performed, current physical characteristics of the site and acreage to be impacted.

___ A map with the project boundary and/or a basic site plan (particularly showing the relationship of the project to the physical features such as wetlands, streams, ponds, rock outcrops, etc.)

In addition to the materials listed above, USFWS REQUIRES the following

___ **SIGNED** copy of a Final Project Environmental Review Receipt

The inclusion of the following information may expedite the review process.

___ Color photos keyed to the basic site plan (i.e. showing on the site plan where and in what direction each photo was taken and the date of the photos)

___ Information about the presence and location of wetlands in the project area, and how this was determined (e.g., by a qualified wetlands biologist), if wetlands are present in the project area, provide project plans showing the location of all project features, as well as wetlands and streams.

4. DEP INFORMATION

The Pa Department of Environmental Protection (DEP) requires that a signed copy of this receipt, along with any required documentation from jurisdictional agencies concerning resolution of potential impacts, be submitted with applications for permits requiring PNDI review. Two review options are available to permit applicants for handling PNDI coordination in conjunction with DEP's permit review process involving either T&E Species or species of special concern. Under sequential review, the permit applicant performs a PNDI screening and completes all coordination with the appropriate jurisdictional agencies prior to submitting the permit application. The applicant will include with its application, both a PNDI receipt and/or a clearance letter from the jurisdictional agency if the PNDI Receipt shows a Potential Impact to a species or the applicant chooses to obtain letters directly from the jurisdictional agencies. Under concurrent review, DEP, where feasible, will allow technical review of the permit to occur concurrently with the T&E species consultation with the jurisdictional agency. The applicant must still supply a copy of the PNDI Receipt with its permit application. The PNDI Receipt should also be submitted to the appropriate agency according to directions on the PNDI Receipt. The applicant and the jurisdictional agency will work together to resolve the potential impact(s). See the DEP PNDI policy at <https://conservationexplorer.dcnr.pa.gov/content/resources>.

5. ADDITIONAL INFORMATION

The PNDI environmental review website is a preliminary screening tool. There are often delays in updating species status classifications. Because the proposed status represents the best available information regarding the conservation status of the species, state jurisdictional agency staff give the proposed statuses at least the same consideration as the current legal status. If surveys or further information reveal that a threatened and endangered and/or special concern species and resources exist in your project area, contact the appropriate jurisdictional agency/agencies immediately to identify and resolve any impacts.

For a list of species known to occur in the county where your project is located, please see the species lists by county found on the PA Natural Heritage Program (PNHP) home page (www.naturalheritage.state.pa.us). Also note that the PNDI Environmental Review Tool only contains information about species occurrences that have actually been reported to the PNHP.

6. AGENCY CONTACT INFORMATION

PA Department of Conservation and Natural Resources

Bureau of Forestry, Ecological Services Section
400 Market Street, PO Box 8552
Harrisburg, PA 17105-8552
Email: RA-HeritageReview@pa.gov

PA Fish and Boat Commission

Division of Environmental Services
595 E. Rolling Ridge Dr., Bellefonte, PA 16823
Email: RA-FBPACENOTIFY@pa.gov

U.S. Fish and Wildlife Service

Pennsylvania Field Office
Endangered Species Section
110 Radnor Rd; Suite 101
State College, PA 16801
Email: IR1_ESPenn@fws.gov
NO Faxes Please

PA Game Commission

Bureau of Wildlife Management
Division of Environmental Review
2001 Elmerton Avenue, Harrisburg, PA 17110-9797
Email: RA-PGC_PNDI@pa.gov
NO Faxes Please

7. PROJECT CONTACT INFORMATION

Name: Kelsey Schwenk
Company/Business Name: FirstEnergy Corporation
Address: 2800 Pottsville Pike
City, State, Zip: Reading, PA 19612-6001
Phone: (484)332-3492 Fax: ()
Email: kmschwenk@firstenergycorp.com

8. CERTIFICATION

I certify that ALL of the project information contained in this receipt (including project location, project size/configuration, project type, answers to questions) is true, accurate and complete. In addition, if the project type, location, size or configuration changes, or if the answers to any questions that were asked during this online review change, I agree to re-do the online environmental review.

Kelsey M Schwenk

applicant/project proponent signature

01/05/2025

date

Exhibit 10



February 26, 2025

IN REPLY REFER TO

SIR# 60578

GAI Consultants, Inc.
Lars Peterson
385 East Waterfront Drive
Homestead, Pennsylvania 15120

**RE: Species Impact Review (SIR) – Rare, Candidate, Threatened and Endangered Species
PNDI Search No. 825372_1
Mountain Substation
South Middleton Township: CUMBERLAND County**

Dear Lars Peterson :

This letter is in response to ongoing consultation between us regarding the potential of the above-referenced project to impact the Eastern Spadefoot (*Scaphiopus holbrookii*). Andy Brookens, a recognized qualified surveyor for the Eastern Spadefoot, evaluated the habitats on site to determine their potential to support the species of concern. According to the report, the site does contain several potential breeding pools and suitable soils in the surrounding uplands. Therefore, Kathy Gipe of my staff and I met with Mr. Brookens on site on February 24, 2025 to consider the project footprint with respect to the identified potential habitats.

During the site visit, we confirmed that the site contained potential habitats for the Eastern Spadefoot. However, the proposed project activities will not directly impact any seasonal pools and are contained to degraded portions of the habitat under the existing electrical lines. Given nearby occurrences of the Eastern Spadefoot but without an onsite presence/absence survey, consider the following recommendations for avoidance and minimization measures that are needed to avoid significant adverse impacts from the proposed development on the Eastern Spadefoot.

If earth moving is confined to the inactive season of the Eastern Spadefoot (November 15-April 15), then no further avoidance is necessary. If earth moving occurs during the active season (April 15-November 15), Eastern Spadefoot toads should be cleared from the construction work area in the vicinity of the ephemeral pools by a qualified Eastern Spadefoot surveyor, who possesses the proper Scientific Collectors' and Endangered Species permits. Following clearance of these construction areas, a silt fence should be installed to prevent reentry of Eastern Spadefoot toads to the construction site. If these avoidance measures can be implemented, along with a strict erosion and sedimentation control plan, then I do not foresee any adverse impacts to the Eastern Spadefoot from the proposed project.

This response represents the most up-to-date summary of the PNDI data and our files and is valid for two (2) years from the date of this letter. An absence of recorded species information does not necessarily imply species absence. Our data files and the PNDI system are continuously being updated with species occurrence information. Should project plans change or additional information on listed or

proposed species become available, this determination may be reconsidered, and consultation shall be re-initiated.

If you have any questions regarding this review, please contact Kathy Gipe at 814-359-5186 or c-kgipe@pa.gov and refer to the SIR # 60578. Thank you for your cooperation and attention to this important matter of species conservation and habitat protection.

Sincerely,

A handwritten signature in black ink that reads "Christopher A. Urban". The signature is written in a cursive style with a large, prominent initial "C".

Christopher A. Urban, Chief
Natural Diversity Section

CAU/KDG/dn

Cc: Andy Brookens

Exhibit 11



January 29, 2025

Sent Via PA-SHARE

RE: ER Project # 2025PR00441.001, Mountain Substation Expansion Project, PA Utility Commission, South Middleton Township, Cumberland County

Dear Submitter,

Thank you for submitting information concerning the above referenced project. The Pennsylvania State Historic Preservation Office (PA SHPO) reviews projects in accordance with state and federal laws. Section 106 of the National Historic Preservation Act of 1966, and the implementing regulations (36 CFR Part 800) of the Advisory Council on Historic Preservation, is the primary federal legislation. The Environmental Rights amendment, Article 1, Section 27 of the Pennsylvania Constitution and the Pennsylvania History Code, 37 Pa. Cons. Stat. Section 500 et seq. (1988) is the primary state legislation. These laws include consideration of the project's potential effects on both historic and archaeological resources.

Above Ground Resources

No Above Ground Concerns - Environmental Review - No Effect - Above Ground

Based on the information received and available within our files, it is our opinion that the proposed project will have No Effect on above ground historic properties, including historic buildings, districts, structures, and/or objects, should they exist. Should the scope of the project change and/or should you be made aware of historic property concerns, you will need to reinitiate consultation with our office using PA-SHARE.

For questions concerning above ground resources, please contact Blair Horton at blahorton@pa.gov.

Archaeological Resources

No Archaeological Concerns - Environmental Review - No Effect - Archaeological

Based on the information received and available in our files, in our opinion, the proposed project should have No Effect on archaeological resources. Should the scope of the project be amended to include additional ground-disturbing activity and/or should you be made aware of historic property concerns regarding archaeological resources, you will need to reinitiate consultation with our office using PA-SHARE.

For questions concerning archaeological resources, please contact Blair Horton at blahorton@pa.gov.

Sincerely,

A handwritten signature in black ink, appearing to read "B. Frederick". The signature is written in a cursive style with a large initial "B" and a distinct "F".

Barbara Frederick
Environmental Review Division Manager

Exhibit 12

MAIT Exhibit 12
Entities or Landowners Associated with the Project

Known persons, corporations and other entities of record owning property within the proposed right-of-way:

Mountain Power LLC
Suite 2000
1360 Post Oak Boulevard
Houston, TX 77056

Entities the Project is Seeking Approval From:

Agency/Address	Permit/Clearance Required	Status
Cumberland County Conservation District 310 Allen Road Carlisle, PA 17013	-Sediment & Erosion Control Plan	Submitted – 1/14/2025 Approved – 2/12/2025

**BEFORE THE
PENNSYLVANIA PUBLIC UTILITY COMMISSION**

LETTER OF NOTIFICATION OF :
MID-ATLANTIC INTERSTATE :
TRANSMISSION, LLC FOR :
APPROVAL OF THE 115 KILOVOLT :
TRANSMISSION LINE : **Docket No.** _____
RELOCATIONS TO MOUNTAIN :
SUBSTATION PROJECT IN SOUTH :
MIDDLETON TOWNSHIP, :
CUMBERLAND COUNTY, :
PENNSYLVANIA :

VERIFICATION

I, Thomas R. Ladson, state that I am a Transmission Specialist II at FirstEnergy Service Company; that I am authorized to make this Verification on behalf of Mid-Atlantic Interstate Transmission, LLC; and that the facts set forth are true and correct to the best of my knowledge, information, and belief. I understand that the statements herein are made subject to the penalties of 18 Pa.C.S. § 4904 (relating to unsworn falsification to authorities).

February 27, 2026



Thomas R. Ladson