



BEFORE
PENNSYLVANIA PUBLIC UTILITY COMMISSION

Application Docket No.
To Be Assigned

Rail Safety Division Application Type (check all that apply):

E-Installation, removal or substitution of warning devices at a public crossing

G-Construction, alteration, relocation, abolition or suspension of a public crossing

P-Installation of traffic signals with preemption on the approach to a public crossing

W-Installation of a fixed utility company's facilities at a public crossing (Pipe & Wire)

X-Exemption from the Commission's railroad clearance requirement

For Applications E/G/P/W use caption 1, for X use caption 2 (delete unused caption):

In re:

(1) Application of Southwest Pennsylvania Railroad Company for approval to alter the public crossing (DOT #145 335S) by upgrading active warning devices to include automatic gates where Burgess field road crosses at grade the track of Southwest Pennsylvania Railroad Company, located in Georges Township in Fayette county.

To Pennsylvania Public Utility Commission:

1. The name, address, telephone number, and e-mail address of the applicant are:

Southwest Pennsylvania Railroad Company
 519 Cedar way
 Bldg1, Suite 100
 Oakmont, PA 15139
 justinsparks@carloadexpress.com

2. The name, address, telephone number, and e-mail address of the applicant's attorney are:

Eric M Hocky Clark Hill, PLC
 Two Commerce Square, 2001 Market Street, Suite 2620,
 Philadelphia, PA 19103
 ehocky@clarkhill.com

3. The SWP Railroad Company would like to upgrade active highway crossing protection to include automatic gates, 12" LED flashing lights, and audible bell.

4. The proposed upgrade will comprise of replacing all underground cables, 5" mast with foundations, and relay signal house. The burgess field Road at grade crossing (DOT# 145 355S) sits at low elevation compared to its surroundings and has poor site distance due to the terrain. Construction of this upgrade is anticipated to begin in July of 2026 if approval is obtained. See As Designed plans attached with this application.

5. The parties that may be affected by the proposed alteration are as follows (see attached Certificate of Service):

Karen Cummings Counsel for Applicant Office of Chief Counsel Pennsylvania Department of Transportation P.O. Box 8212, Harrisburg, PA 17105-8212 kcummings@pa.gov

Mark Chappell P.E. Chief Right of Way, Utilities & Grade Crossing Division
Pennsylvania Department of Transportation P.O. Box 3362, Harrisburg, PA 17105-3362 marhappel@pa.gov

Thomas A Ryczek Jr District Grade Crossing Engineer / Turnpike Coordinator
PA Department of Transportation Engineering District 12-0 825 N Gallatin Ave Ext Uniontown, PA 15401
tryczek@pa.gov

Amy Revak, Fayette County Commissioners 61 East Main Street Uniontown, PA 15401 arevak@fayettepa.org

Linda M Smith, Georges Township 1151 Township Drive Uniontown, PA 15401 lsmith@georgestownship.com

Fairchance Georges Joint Municipal Sewage Authority
80 N Morgantown St Fairchance, PA 15436 billing@fgjmsa.com

Frank Mutnansky The North Fayette County Municipal Authority PO Box 368 1634 University Drive Dunbar, PA 15431 frank@nfcma.org

William B Carnahan 4100 William Penn Hwy Ste 44, Monroeville, PA 15146 Verizon Western/Central PA
william.b.carnahan@verizon.com

6. [Not a State Route - traffic unknown
1 train movement in morning 1 train movement in afternoon

7. The estimated cost to perform this project is \$50,000

8. The application is necessary or proper for the following reason(s):

The Southwest Pennsylvania Railroad will pay all cost for the upgrade and continue to maintain the active warning devices.

Wherefore, we pray your Honorable Commission to approve the application:



(Signature of Applicant)

VERIFICATION

I, **Justin Sparks**, hereby state that the facts above set forth are true and correct (or are true and correct to the best of my knowledge, information and belief) and that I expect to be able to prove the same at a hearing held in this matter. I understand that the statements herein are made subject to the penalties of 18 Pa. C.S. § 4904 (relating to unsworn falsification to authorities).

03-05-2026

Date

A handwritten signature in cursive script that reads "Justin Sparks". The signature is written in black ink and is positioned above a horizontal line.

(Signature)

CERTIFICATE OF SERVICE

I hereby certify that I have this day served a true copy of the foregoing document upon the participants, listed below, in accordance with the requirements of § 1.54 (*relating to service by participant*).

Karen Cummings Counsel for Applicant Office of Chief
Counsel Pennsylvania Department of Transportation
P.O. Box 8212, Harrisburg, PA 17105-8212
kcummings@pa.gov

Mark Chappell P.E. Chief Right of Way, Utilities &
Grade Crossing Division
Pennsylvania Department of Transportation P.O. Box
3362, Harrisburg, PA 17105-3362 marhappel@pa.gov

Thomas A Ryczek Jr District Grade Crossing
Engineer / Turnpike Coordinator
PA Department of Transportation Engineering District
12-0 825 N Gallatin Ave Ext Uniontown, PA 15401
tryczek@pa.gov

Amy Revak, Fayette County Commissioners 61 East
Main Street Uniontown, PA 15401
arevak@fayettepa.org

Linda M Smith, Georges Township 1151 Township
Drive Uniontown, PA 15401
lsmith@georgestownship.com

Fairchance Georges Joint Municipal Sewage Authority
80 N Morgantown St Fairchance, PA 15436
billing@fgjmsa.com

Frank Mutnansky The North Fayette County Municipal
Authority PO Box 368 1634 University Drive Dunbar,
PA 15431 frank@nfcma.org

William B Carnahan 4100 William Penn Hwy Ste 44,
Monroeville, PA 15146 Verizon Western/Central PA
william.b.carnahan@verizon.com

[List names, addresses and email addresses
of participants served.

Participants shall include the Pennsylvania
Department of Transportation, the Railroad
Company, the county and municipality where
the crossing is located, and any fixed utility
companies with facilities at the crossing.
The applicant is responsible to serve all
parties a copy of its application and
associated exhibits. The Commission does
not serve any party on your behalf.]

(Continues next page)

CERTIFICATE OF SERVICE

I hereby certify that I have this day served a true copy of the foregoing document upon the participants, listed below, in accordance with the requirements of § 1.54 (*relating to service by participant*).

[List names, addresses and email addresses of participants served.]

Participants shall include the Pennsylvania Department of Transportation, the Railroad Company, the county and municipality where the crossing is located, and any fixed utility companies with facilities at the crossing.

The applicant is responsible to serve all parties a copy of its application and associated exhibits. The Commission does not serve any party on your behalf.]

[List names, addresses and email addresses of participants served.]

Participants shall include the Pennsylvania Department of Transportation, the Railroad Company, the county and municipality where the crossing is located, and any fixed utility companies with facilities at the crossing.

The applicant is responsible to serve all parties a copy of its application and associated exhibits. The Commission does not serve any party on your behalf.]

Dated this 5 day of March , 20 26



(Signature)

Carload Express

Southwest Pennsylvania Railroad FM & P Subdivision Burgess Field Road Highway Crossing Book of Plans Georges Township, PA

As Designed

Carload Express, Inc.
319 Cedar Way
Bldg. I, Suite 100
Oakton, PA 15139

Designed: JIS
Drawn: JIS
Approved: JIS

FM & P Subdivision

Sheet 1 of 11
Drawing No C001

Revisions

Southwest Pennsylvania Railroad
Communication and Signal Department
Burgess Field Road
Cover
DOT #1453355 MP. F 74.88

Revisions

Drawing No.	Revision	Description
C001	0	Cover Page
I001	0	Index
T001	0	Track and Cable Plan
E001	0	Control Circuits
E002	0	Flasher Circuits
G001	0	Gate Circuits
P001	0	Power and Lighting Circuits
W001	0	House Layout 'A'
W002	0	House Layout 'B'
W003	0	House Layout 'C'
W004	0	House Layout 'D'

As Designed

Cardinal Express, Inc.
 319 Cedar Way
 Bldg 1, Suite 100
 Oakmont, PA 15139

Designed: JIS
 Drawn: JIS
 Approved: JIS

FM & P Subdivision

Sheet 2 of 11
 Drawing No 1001

Southwest Pennsylvania Railroad
 Communication and Signal Department
 Burgess Field Road
 Index
 DOT #1453355 MP. F 74.88



Burgess Field Road

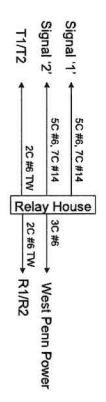
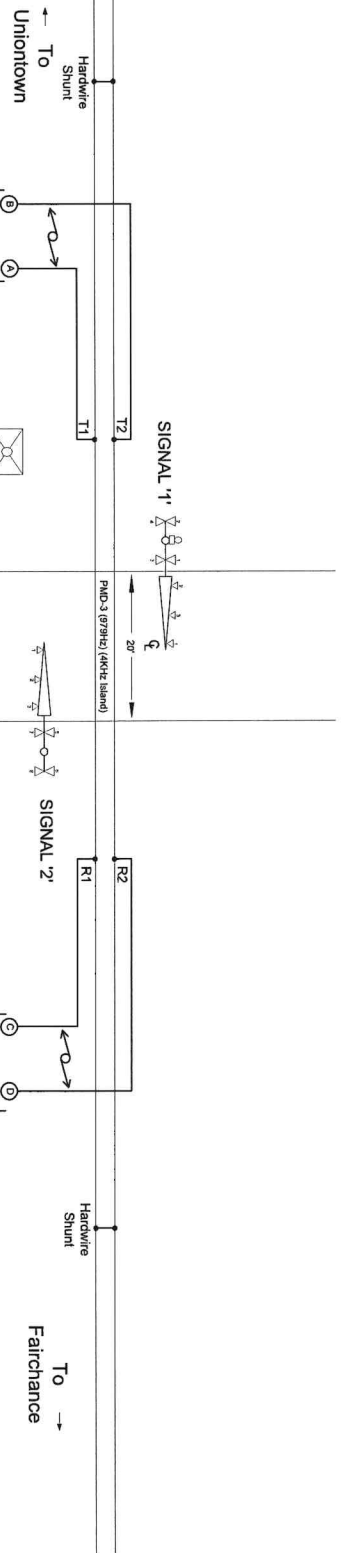

LOCATION	Burgessfield Road
FREQUENCY	979HZ 4K RSI FLT0
TERMINATION	HWS
OVERLAPPING FREQ	None
	TRACK #1
Minimum Track Clearance Distance	<35'
Maximum Authorized Train speed	10 MPH 14.7 FPS
Minimum Time (MT)	30 441
Clearance Time (CT)	0 0
Exit Gate Clearance Time (EGCT)	0 0
Prescribed Warning Time (PWT)	30 441
Buffer Time (BT)	0 0
ERT - Control (ERT-C)	3 44.1
ERT - Delay (ERT-D)	0 0
Programmed Warning Time	33 485.1
Advance Preemption Time (APT)	0 0
ERT - Acquisition (ERT-A)	4 58.8
System Design Time (SDT)	37 543.9

Revisions	
-----------	--

As Designed

Carload Express, Inc.
519 Cedar Way
Bldg I, Suite 100
Oakmont, PA 15139

Southwest Pennsylvania Railroad
Communication and Signal Department

Burgess Field Road
Track and Cable Plan
DOT #145335S MP. F 74.88

FM & P Subdivision

Design: JIS
Draw: JIS
Approval: JIS

Sheet 3 of 11
Drawing No T001

As Designed

Cardinal Express, Inc.
519 Cedar View
Bldg. I, Suite 100
Oakmont, PA 15189



Design: JIS
Drawn: JIS
Approved: JIS

Southwest Pennsylvania Railroad
Communication and Signal Department
Burgess Field Road
Control and Flasher Circuits
DOT #1453355 MP. F.74.88

PM & P Subdivision

Sheet 4 of 11

Drawing No E001

Notes:
 DENOTES TWISTED PAIR
 DENOTES GOLD TEST TERMINAL

Continued on
Drawing No. T001

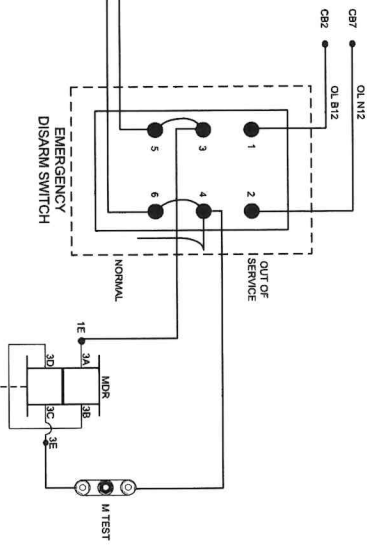
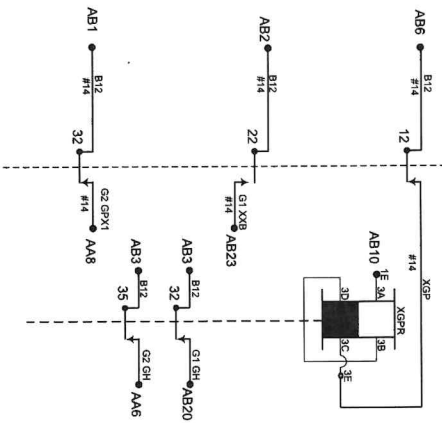
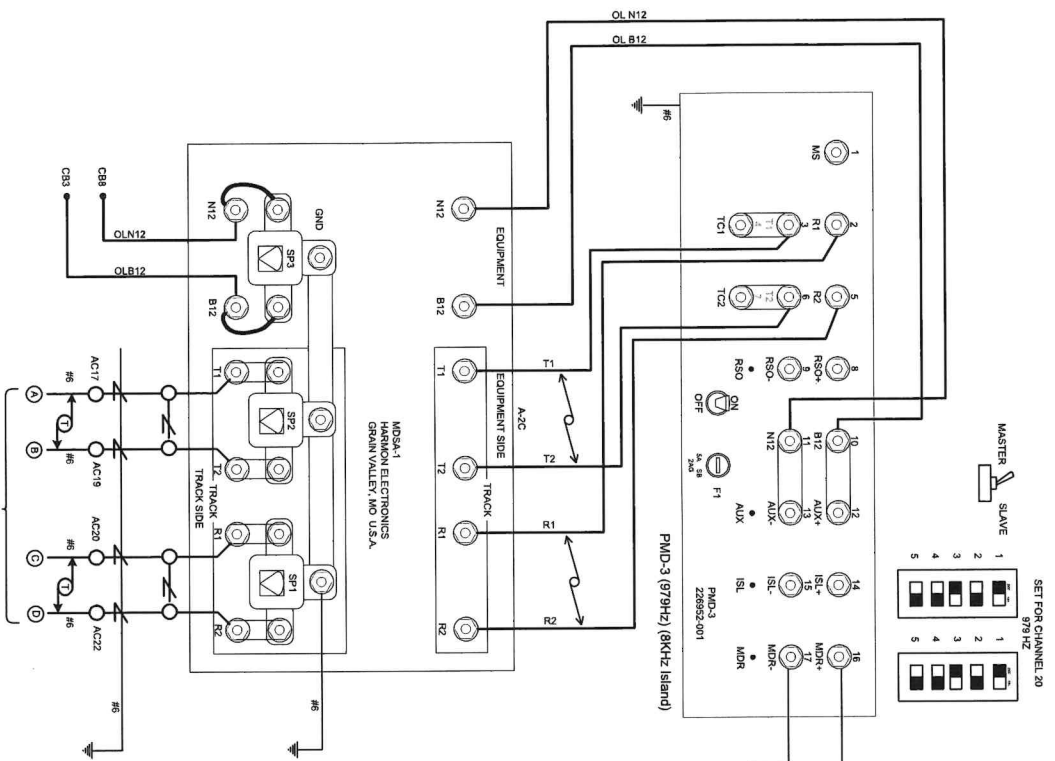

Revisions

As Designed

Cardox Express, Inc.
519 Cedar Way
Bldg. I, Suite 100
Oakmont, PA 15139

Designed: JIS
Drawn: JIS
Approved: JIS

Sheet 5 of 11
Drawing No E002

Southwest Pennsylvania Railroad
Communication and Signal Department
Burgess Field Road
Flasher Layout Circuits
DOT #145385S MP F 74.88

FM & P Subdivision

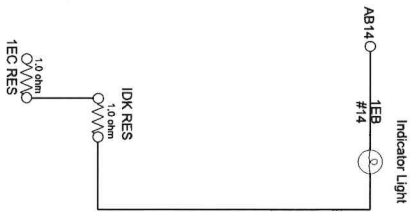
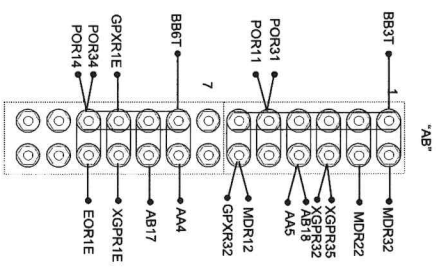
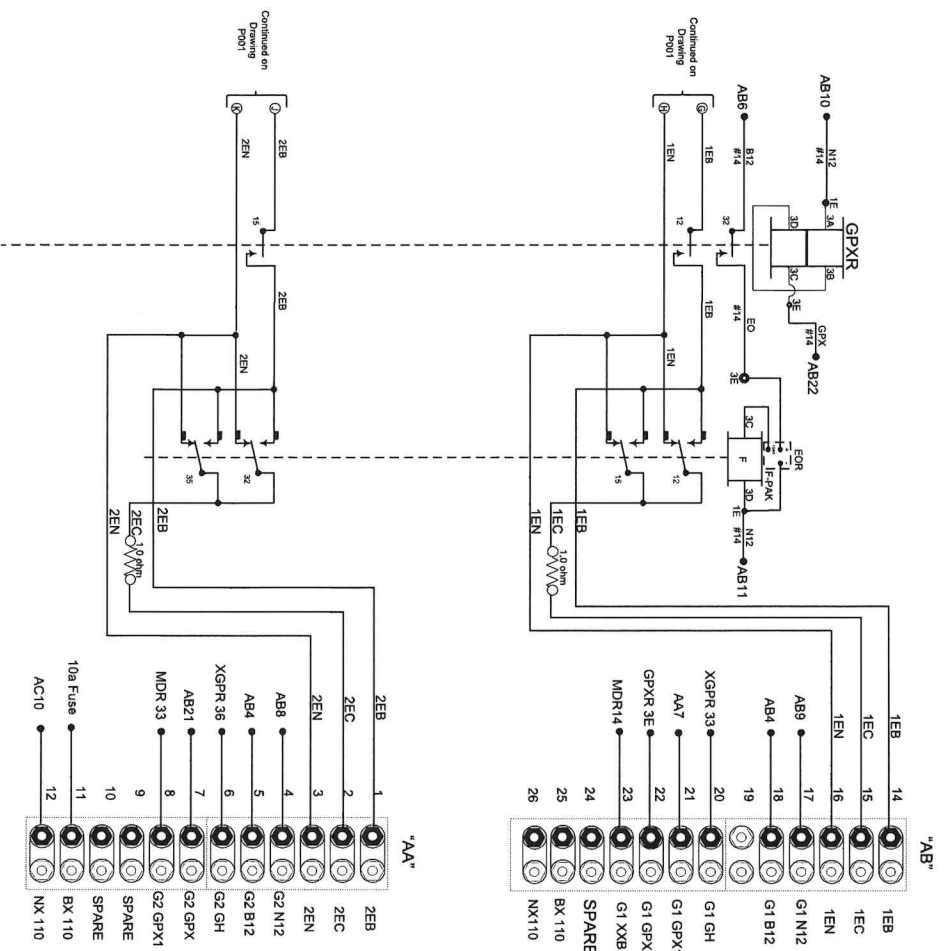

Revisions

--	--	--

Contact	Closed	Function	Tension
1B	75-90 Degrees	Power Down	18-28 OZ
2	0-70 Degrees	Shud Down	18-28 OZ
3	0-86 Degrees	Power Up	18-28 OZ
4	0-10 Degrees	Gate Down	16-24 OZ
5	82-90 Degrees	Gate Clear	16-24 OZ
6	10-90 Degrees	Bell	16-24 OZ
7	Spare	Spare	16-24 OZ
	0-10 Degrees	Shud	16-24 OZ

As Designed

Cardox Express, Inc.
519 Cedar Way
Bldg 1, Suite 100
Oakmont, PA 15189

Designed: JIS
Drawn: JIS
Approved: JIS

● DENOTES GOLD TEST TERMINAL
ALL WIRES #10 UNLESS OTHERWISE NOTED

Southwest Pennsylvania Railroad
Communication and Signal Department
Burgess Field Road
Gate Circuit
DOT #1453355 MP F 74.88

FM & P Subdivision

Sheet 6 of 11

Drawing No G001

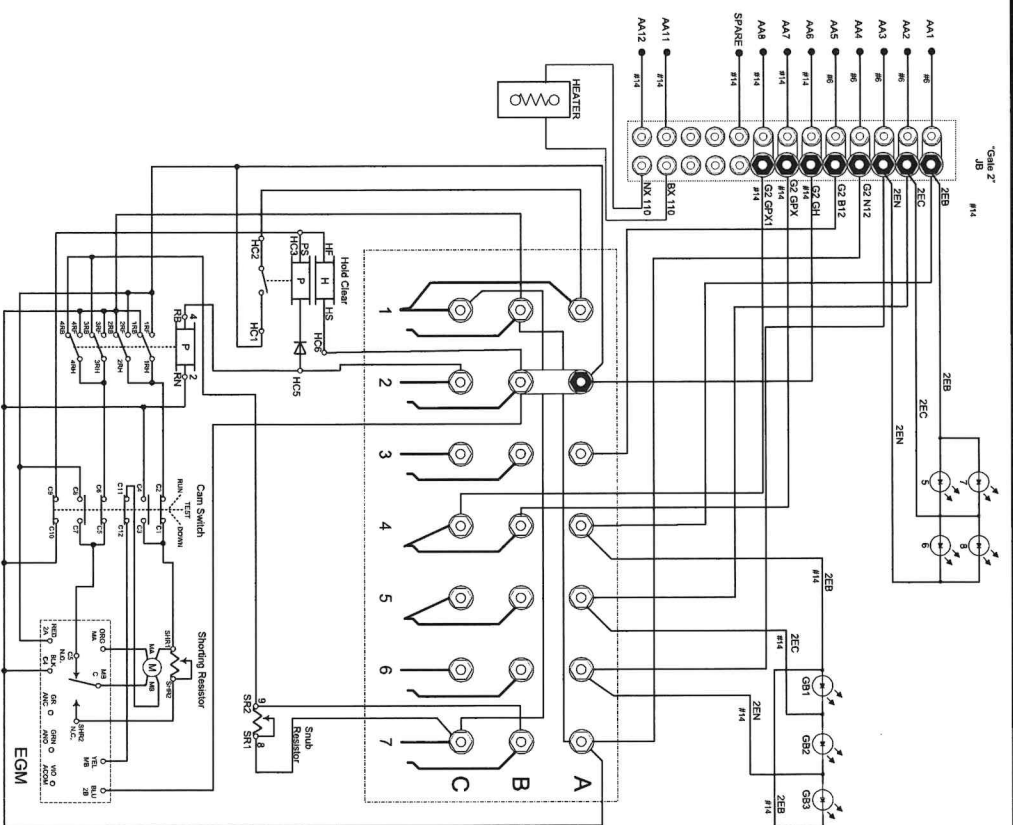
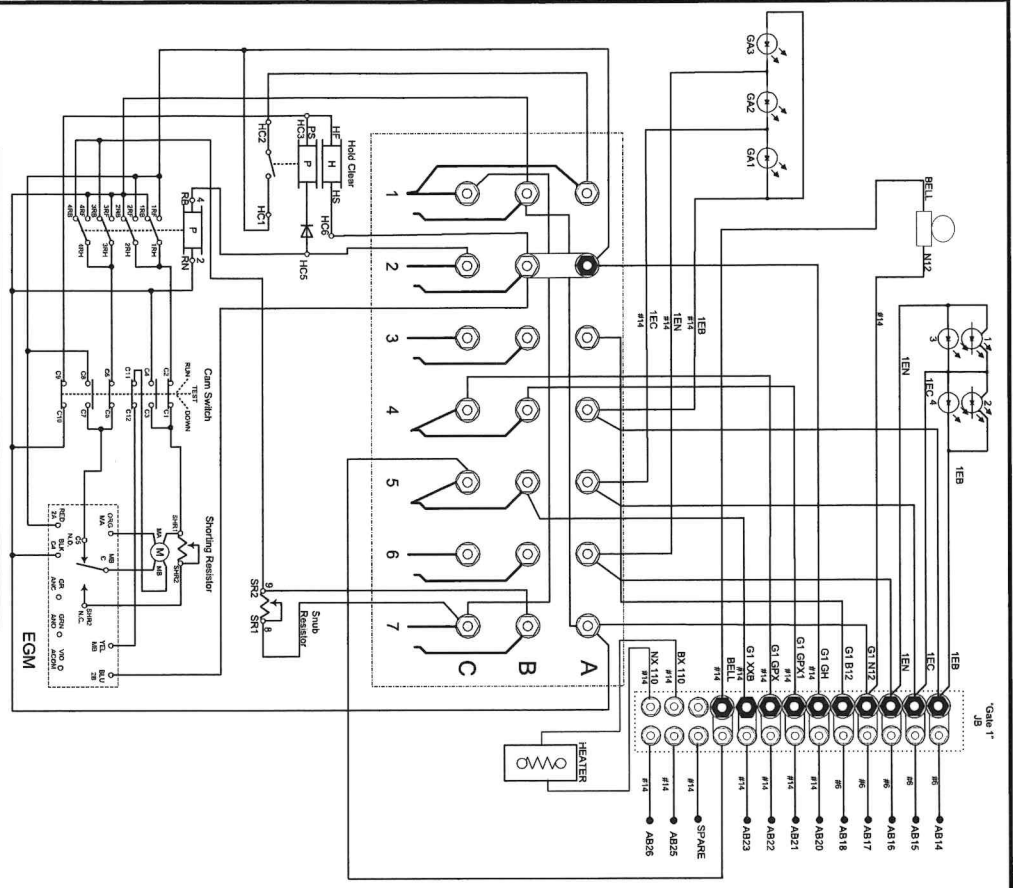

Revisions

--	--

As Designed

Cardinal Express, Inc.
 519 Cedar Way
 Bldg. 1, Suite 100
 Oakton, PA 15139

Designed: JIS	Sheet 7 of 11
Drawn: JIS	Drawing No P001
Approved: JIS	

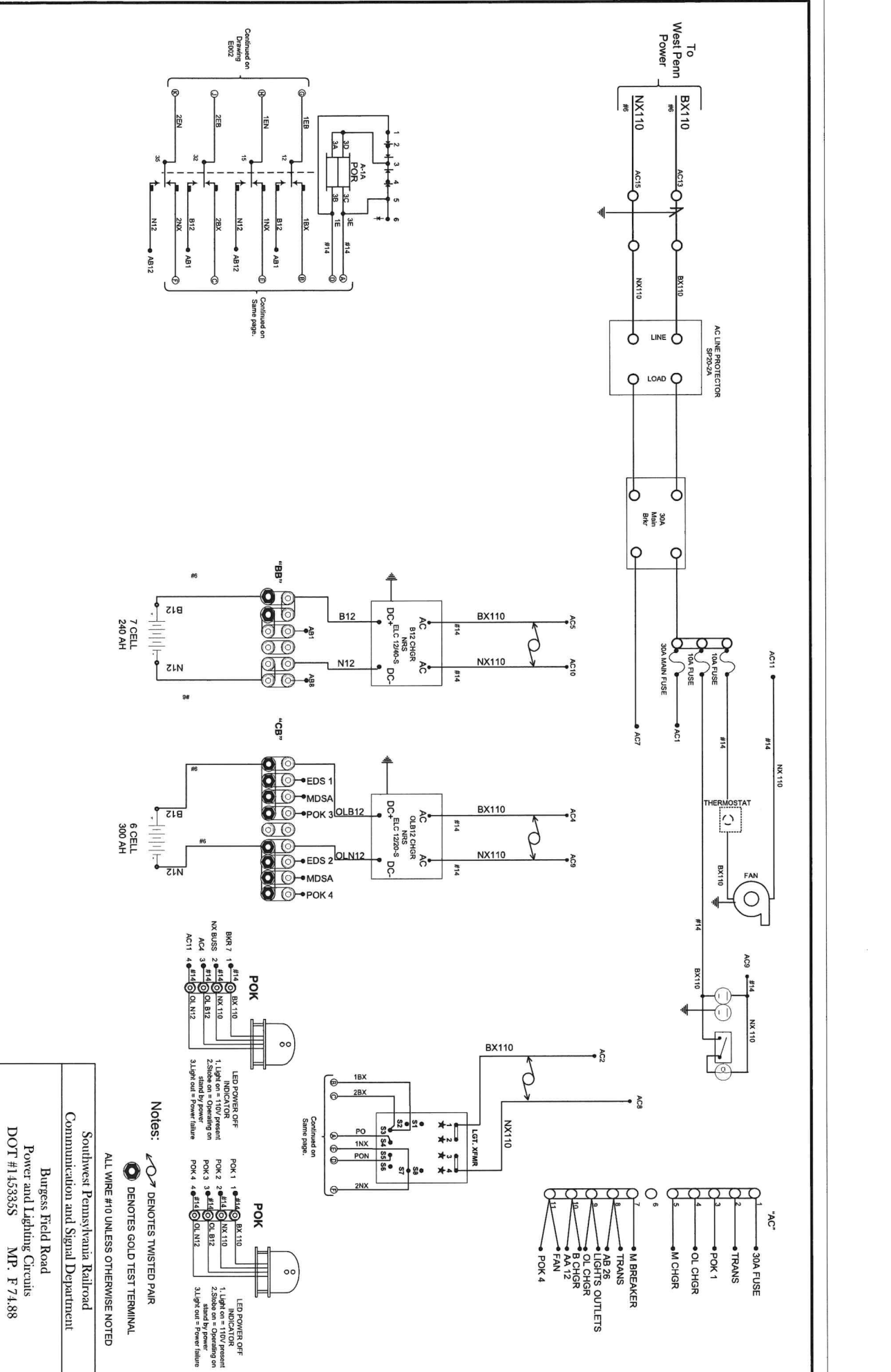

Notes:

- ⚡ DENOTES GOLD TEST TERMINAL
- ALL WIRE #10 UNLESS OTHERWISE NOTED

POK 1 1-#14 BX110
 LED POWER OFF INDICATOR
 1. Light on = 110V present
 2. Slides on = Operating on stand by power
 3. Light out = Power failure

POK 2 2-#14 NX110
 LED POWER OFF INDICATOR
 1. Light on = 110V present
 2. Slides on = Operating on stand by power
 3. Light out = Power failure

POK 3 3-#14 OL B12
 LED POWER OFF INDICATOR
 1. Light on = 110V present
 2. Slides on = Operating on stand by power
 3. Light out = Power failure

POK 4 4-#14 OL N12
 LED POWER OFF INDICATOR
 1. Light on = 110V present
 2. Slides on = Operating on stand by power
 3. Light out = Power failure

Southwest Pennsylvania Railroad
 Communication and Signal Department
 Burgess Field Road
 Power and Lighting Circuits
 DOT #1453355 MP, F 74.88

Cardinal Express, Inc.
 519 Cedar Way
 Bldg. 1, Suite 100
 Oakton, PA 15139

Continued on Drawing E002

Continued on Same page

'B'

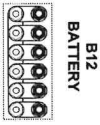
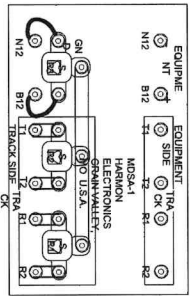

B12 CHGR
NRS
ELC 12/40-S

PMD-3

7 CELLS MAINT
FREE 300 AH
B12 BATTERY

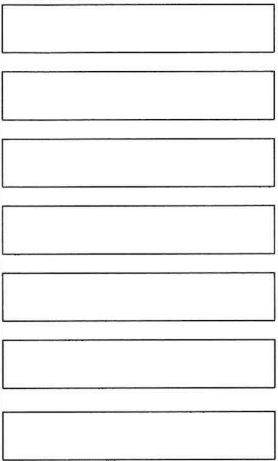

As Designed

Cardinal Express, Inc.
519 Cedar Way
Bldg 1, Suite 100
Oakton, PA 15139

Designed: JIS
Drawn: JIS
Approved: JIS

FM & P Subdivision

Sheet 9 of 11

Drawing No W002

Southwest Pennsylvania Railroad
Communication and Signal Department
Burgess Field Road
House Layout 'B'
DOT #1453355 MP. F 74.88

Revisions

'C'

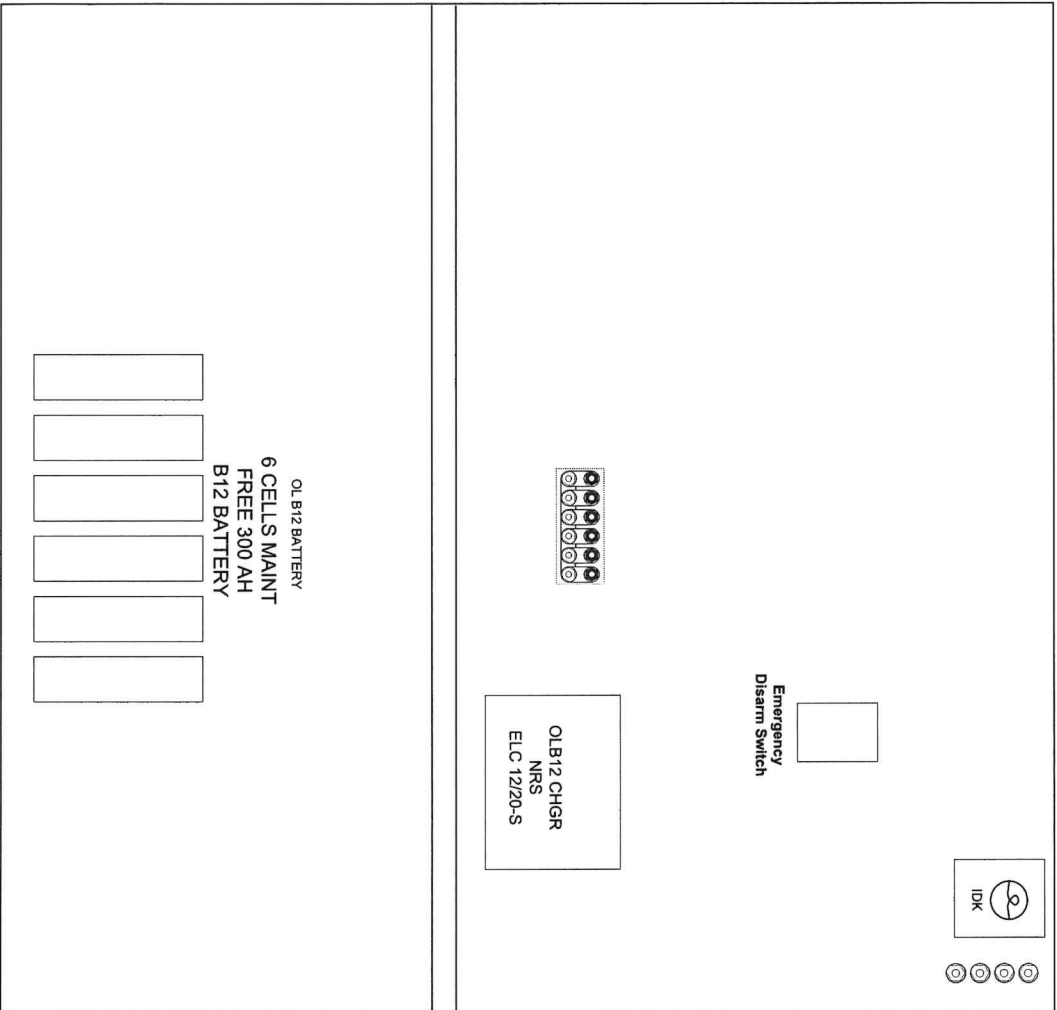

Notes:

Southwest Pennsylvania Railroad
Communication and Signal Department
Burgess Field Road
House Layout 'C'
DOT #145355 MP. F 74.88

EM & P Subdivision
Designed: JIS
Drawn: JIS
Approved: JIS
Sheet 10 of 11
Drawing No W003

Cardinal Express, Inc.
519 Cedar Way
Bldg. I, Suite 100
Oakton, PA 15139

As Designed

Revisions

'D'

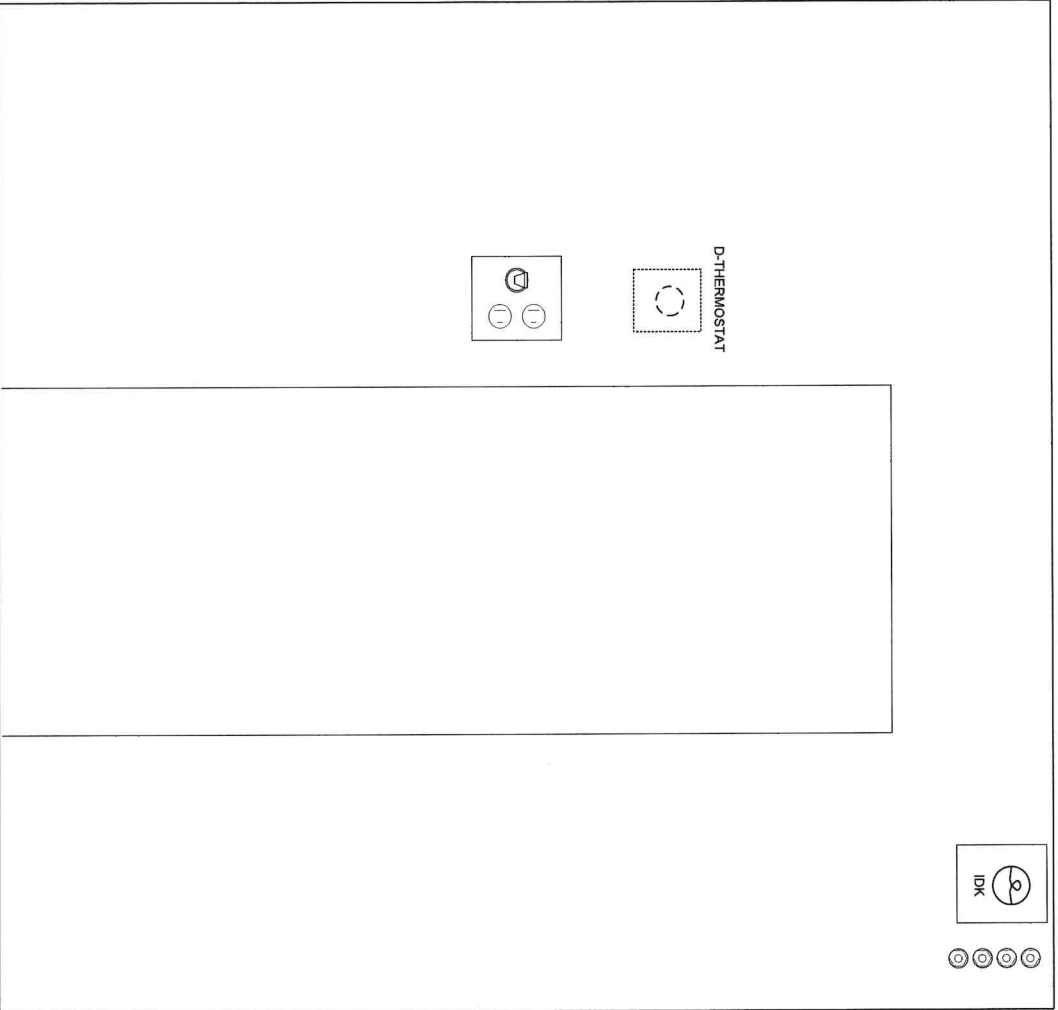

As Designed

Carload Express, Inc.
519 Cedar Way
Bldg 1, Suite 100
Oakton, PA 15139

Designed: JIS
Drawn: JIS
Approved: JIS

Southwest Pennsylvania Railroad
Communication and Signal Department
Burgess Field Road
House Layout 'D'
DOT #1453355 MP. F74.88

FM & P Subdivision

Sheet 11 of 11

Drawing No W7004