

**BEFORE
PENNSYLVANIA PUBLIC UTILITY COMMISSION**

In re: Application of Gigapower LLC for approval of the alteration of the crossing 249617X by the installation of fiber optic cable where Salem St crosses above grade of the tracks of Delaware-Lackawanna Railroad, located in the Borough of Archbald in Lackawanna County. Application Docket No.

To Pennsylvania Public Utility Commission:

1. The name and address of applicant are:

GIGAPOWER, LLC (see local mailing address pg. 2)
311 S Akard St. – 21st Floor
Dallas, TX 75202

2. The name and address of applicant's attorney are:

Thomas Grace - CCO and Chief Counsel

GIGAPOWER, LLC
311 S Akard St. – 21st Floor
Dallas, TX 75202

3. GIGAPOWER, LLC provides Optical Network Infrastructure for use by Internet Service Providers and other data transmission.
4. Adding a figure-8 aerial duct and fiber optic cable attached to the existing joint use pole 60538-N49217 located at (41.4967500, -75.5384299) 50 ft West from the crossing the Delaware-Lackawanna Railroad (41.496657 -75.538256) and Salem St. and to the joint use pole 60545-N49215 (41.4967057, -75.5380853) 48 ft East from the crossing. The cable will pass above the railway. No attachments will be made to the beams, head wall, or any part of the rail bridge structure.
5. The following public utilities who may be affected by or concerned with the proposed alteration of the crossing are Pennsylvania Power and Light, Verizon, Xfinity, Frontier, T-Mobile, Astound Broadband, Service Electric Cable TV. The following municipalities of Borough of Archbald who may be affected by or concerned with the proposed alteration of the crossing are the . The following property owners who may be affected by or concerned with the proposed alteration of the crossing are Delaware & Lackawanna Railroad.
6. Estimated cost of construction not to exceed \$10,000 – Gigapower LLC. Is responsible for the installation, maintenance, and inspection of such facilities and will be the responsible for all associated costs related to the installation, maintenance, and inspection of such facilities.

7. The alteration is necessary or proper for the following reasons: To provide the residence of the Borough of Archbald with access to high quality fiber internet.

Wherefore, applicant prays your Honorable Commission to approve the application:

Rich Rehak Jr.
Director of Network Operations NEPA
GIGAPOWER, LLC
Po BOX 179
East Greenville, PA 18041

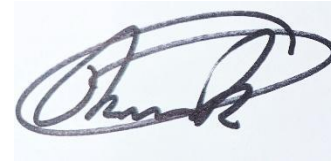

(Signature of Applicant)

§ 1.36. Verification.

- (a) Applications, petitions, formal complaints, motions and answers thereto containing an averment of fact not appearing of record in the action or containing a denial of fact shall be personally verified by a party thereto or by an authorized officer of the party if a corporation or association. Verification means a signed written statement of fact supported by oath or affirmation or made subject to the penalties of 18 Pa. C.S. §4904 (relating to unsworn falsification to authorities). If verification is required, notarization is not necessary.
- (b) The Verification form should comply substantially with the following:

VERIFICATION

I, Rich Rehak Jr. , hereby state that the facts above set forth are true and correct (or are true and correct to the best of my knowledge, information and belief) and that I expect to be able to prove the same at a hearing held in this matter. I understand that the statements herein are made subject to the penalties of 18 Pa. C.S. § 4904 (relating to unsworn falsification to authorities).

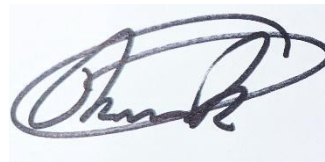

Date: March 23, 2028

(Signature)

CERTIFICATE OF SERVICE

I hereby certify that I have this day served a true copy of the foregoing document upon the participants, listed below, in accordance with the requirements of § 1.54 (relating to service by participant).

Railroad:

*Pennsylvania Northeast Regional Authority (Owner)
Charlene Doyle, Sr Vice President of Administration cdoyle@pnrra.org
280 Cliff St, Scranton, PA 18503*

*Delaware-Lackawanna Railroad
Lorie Ransom, General Superintendent lransom@pnrra.org
280 Cliff St, Scranton, PA 18503*

*PADOT: Jeremiah Gonzalo
jgonzalo@pa.gov
55 Keystone Industrial Park, Dunmore, PA 18512*

*Borough of Archbald, Brian Dulay
bdulay@archbaldboroughpa.gov
400 Church St., Archbald, PA 18403*

*PPL: Rana Souryal
rsouryal@pplweb.com
P.O. Box 25239, Lehigh Valley, PA 18002-5239*

*Verizon Pennsylvania Inc.: Deborah Barum
poleconduitadmin1@verizon.com, dgcavuto@ctdi.com
1026 Hay St., Wilkesburg, PA 15221*

*North Penn Long Distance Corporation: Empire/North Penn Telephone
ospeng@etcnpt.com
34 Main Street, Prattsburgh, NY 14873*

*Comcast - Duryea: Americomm
carol@americomm-llc.com, heather@americomm-llc.com
21 State Ave (Suite 1), Carlisle, PA 17013*

*ION Holdco LLC: Sheena Wiater
scharney@firstlight.net, swiater@firstlight.net, smercier@firstlight.net, flf-licensing@firstlight.net,
rsitler@firstlight.net
7890 Lehigh Crossing, Victor, NY 14564*

*Teleport Communications America LLC: MCarlo Verdi III
cverdi@att.com, jay@treccgroup.com
900 Old Marple Rd., Springfield, PA 19064*

*CTSI, LLC: Mary Rodman
PA.Structure.Access@ftr.com
100 CTE Drive, Dallas, PA 18612*

*ZitoMedia / Zito West Holding, LLC: Kelly Ragosta
kelly.ragosta@zitomedia.com
PO Box 665 - 102 South Main Street, Coudersport, PA 16915*

*XO Communications, Inc.: Scott Dreiling
scott.j.dreiling@xo.com
1220 Broadcasting Road, Wyomissing, PA 19610*

Chris Sloce

Dated this 23rd day of March, 2026

(Signature)

h0Vhk-h'k'u@V
 \t V-k
 8@h\t-k
 h\ "\CE
 -' au8k-Vt@ h'
 V@V O'' u=-k=\Q
)@-#u\k\7V-ut \kMh-k'u@Vo
 V@V O'' u=-k=\Q 8@h\t-k#\U
 k@=k=-'M
 \yuo@-hO Vuoy"K#uU'uu-k'-@-ku
 k@=k=-'M 8@h\t-k#\U
)'V@Oou-UJ'#M
 #\Vouky#u@V O')'h'
)'V@Oou-UJ'#M 8@h\t-k#\U
 -V8@-k@87@U
 #\kV@8hO#-
 #='kOuu- V#
 -)t @k\8-ko
 hk\8k'U U'V'8-k
 k\8-ko- #\kV@8#\U
 -)@O,t-
 o-V@k\yuo@-hO Vu'-V8@-k
 O,t--') #\kV@8#\U
 h-kU@)k't V''
 #=k@O@#-
 ok\ch-V8
 o@#-# #\kV@8#\U

hk\K#u@V
 U'ou-khk\K#u 8@h\t-k' V-\V O@'
 hk\K#uV'U-'
 #\kV@8hk\K#uVyU"-k' h'
 hhO'hhO# u@V VyU"-k'
 \kU 7k'7)'u'
 k'@'\')-O't'k'-O#M't'VV'k'@'\')O
 "k'V#=\k'O@-V'U- #'k'\V)'O'U'@
 kk'U@h\au
 V-'k-ouu@-u'"O'au'u@V "'k#=""'Q
 u@-u'"O'ch--') V'

8=GHF=7H	7CI BHM	6CFCl ; <	FCI H9	G9; A9BH	C : G9H	HCH5@ G<99HG
()	5F7<65@8	%\$(%)	\$\$&\$!!!!	-
)	5F7<65@8	%\$(%)	\$\$&\$!!!!	

hy" O@# yu@u@o#\ U U @oo@V'
 k° @k\ °) 'h-kU @u° hhO@° u@V
 #k\oo@8 VyU "-k 'g Jî Fî Y'
 i° Q U'ou
 ° k#="" ° Q 'h°
 O #M t ° VV° #\yVu'

G<99H' =B89L	
:! \$\$%	7CJ 9F' G<99H
:! \$\$&	BCH9G
:! \$\$'	@9; 9B8
7! \$\$(<	D@5B' CJ 9FJ =9K
7! \$\$)	DFC: =@9 5
7! \$\$*	DFC: =@9 6
N!) \$%	DC@9 89H5=@G

)° u-'

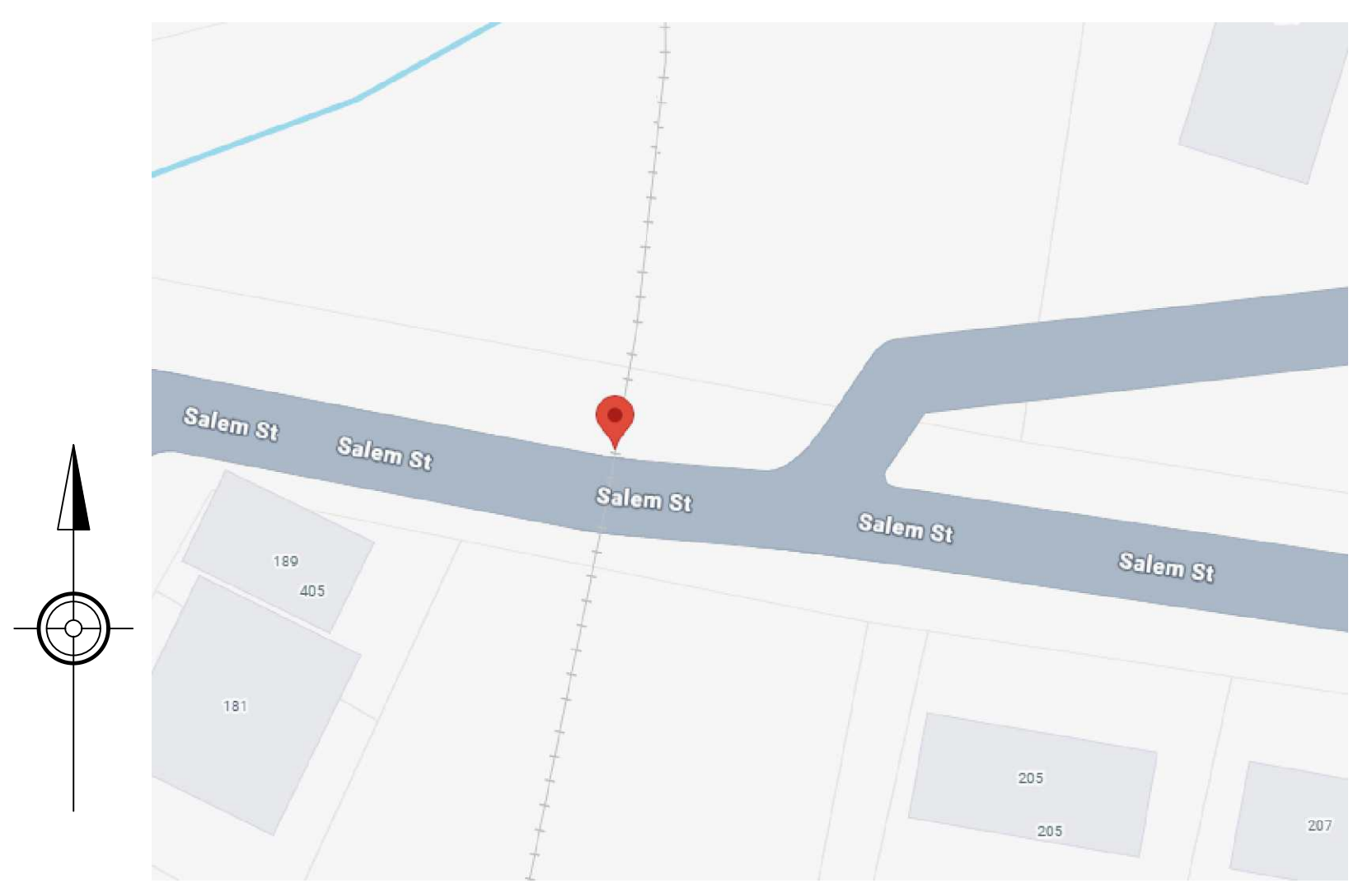

Q #° u@V U° h
 Vuo

ou° u-'=t' _____
 "\k\y8='ouk--uo - - - - -
 t° u-k t' ' _____
 hk\K#u@V @o - - - - -

h-VVo' O'° V@

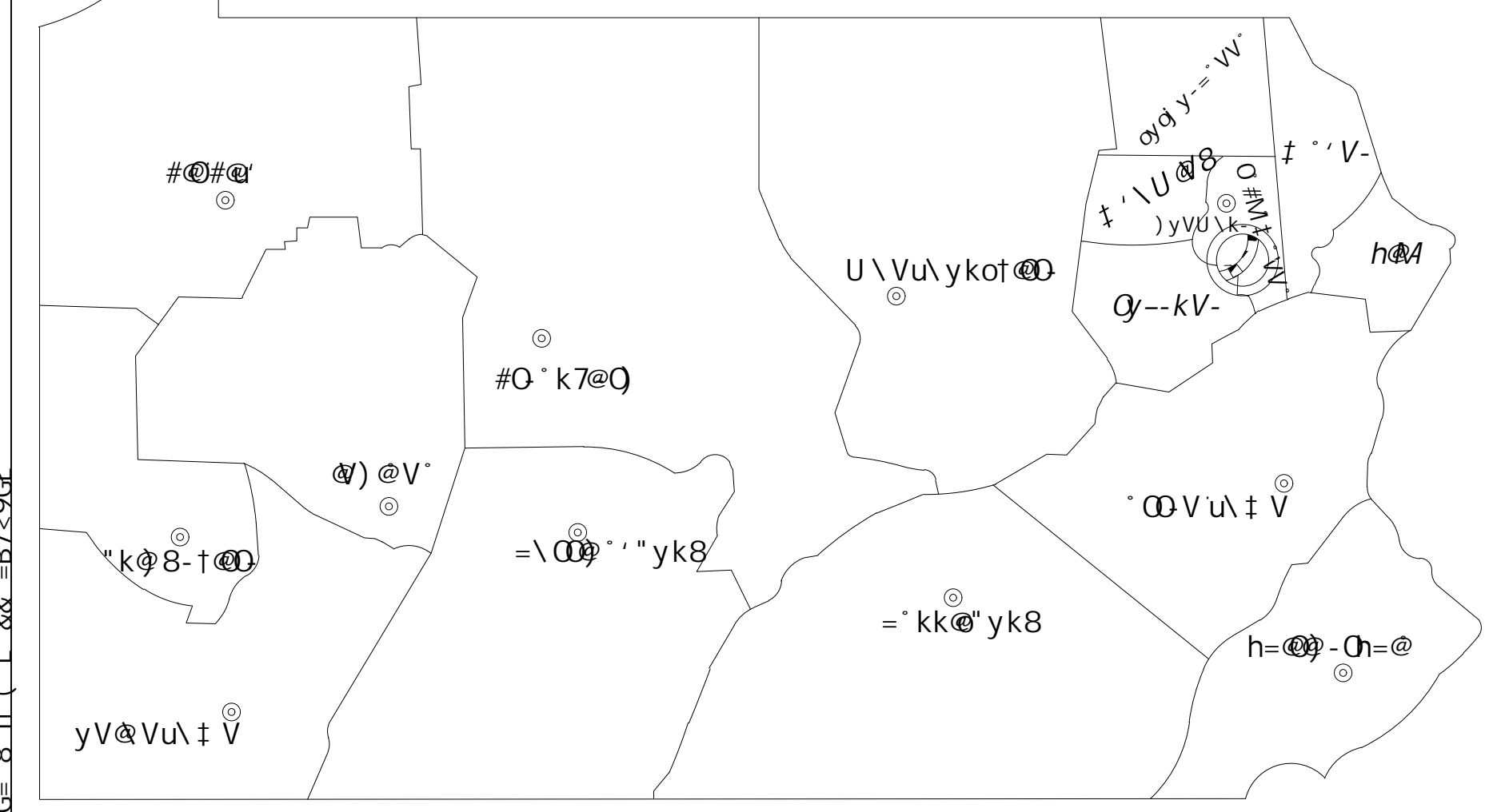

hk\K#u@V

F9J=G=CBG		
F9J	85H9	89G7F=DH=CB

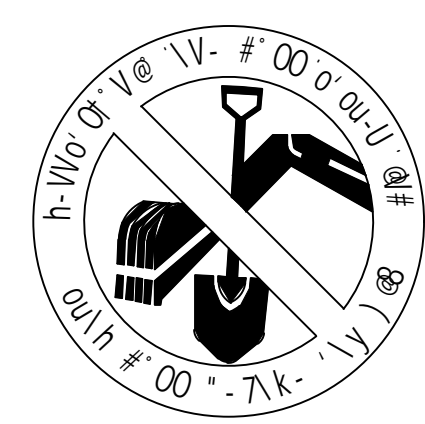

#'O° -\k-' \y) @
 h-VVo' O'° V@' O' t' k-j y@-o' u\ ' t' \kM@8) ' 'oV\ u@- \k #\ Vouky#u@V
 h='o' " 'o-) \Vhk\K#u#\U hO (@ ' " V) ' ' t' \kM@8) ' ' o@) -o@V ou' 8-
 ou\h# " O
 u=- h' \V- #' OOV\ u@# u@Voh-k\kU-) yk@8hk\K#u)-t-O.hU -Vu" k-
 'o\k\k t o
 hk-O@ @' k') -o@V'o-k@OV\ 'o-k@OVyU"-k \V') 'u- \k

) -o@V) -o@V° u@V
 =@t' ' #O o@# u@V 7k--' ##-oo
) -o@V (h--) U h=
 h' t-U-Vu t @u=
 o=\yQ -k t @u=

D@CH: 85H9 . . #.% #&\$& z' _CF =: =B5@ G=N9 5BG= : 8 fl (. L . && =B7<9CH

0.#' u@V)' u'				o=- -uV\
)@uk@u	#\yVu'	k\yu-	o-8U -Vu	\ 77o-u
hk\K#uV' U-				# \ 7
\k@V' O)' u- U				
)k' ‡ @8V' U- hk\ 7@''				
)k' ‡ @8o#' O				



hk\h\o-) ' ° 7 '#u° -k@07@-k
 @' 7@yk- 'o-07'oyhh\ ku@8
 ° -k@0) y#u

ÚÒP P ÙÿŠX@P QÁUUY ÒÜ
 Í É I Í È I JGFÍ
 OÈ/VO@P Á@V/K@ CÄ
 ŠOÈ/KÁ FÈ JÍ I Í É I
 ŠUPŒKÄ Í È H I GJJ

AERIAL RR PROFILE OE

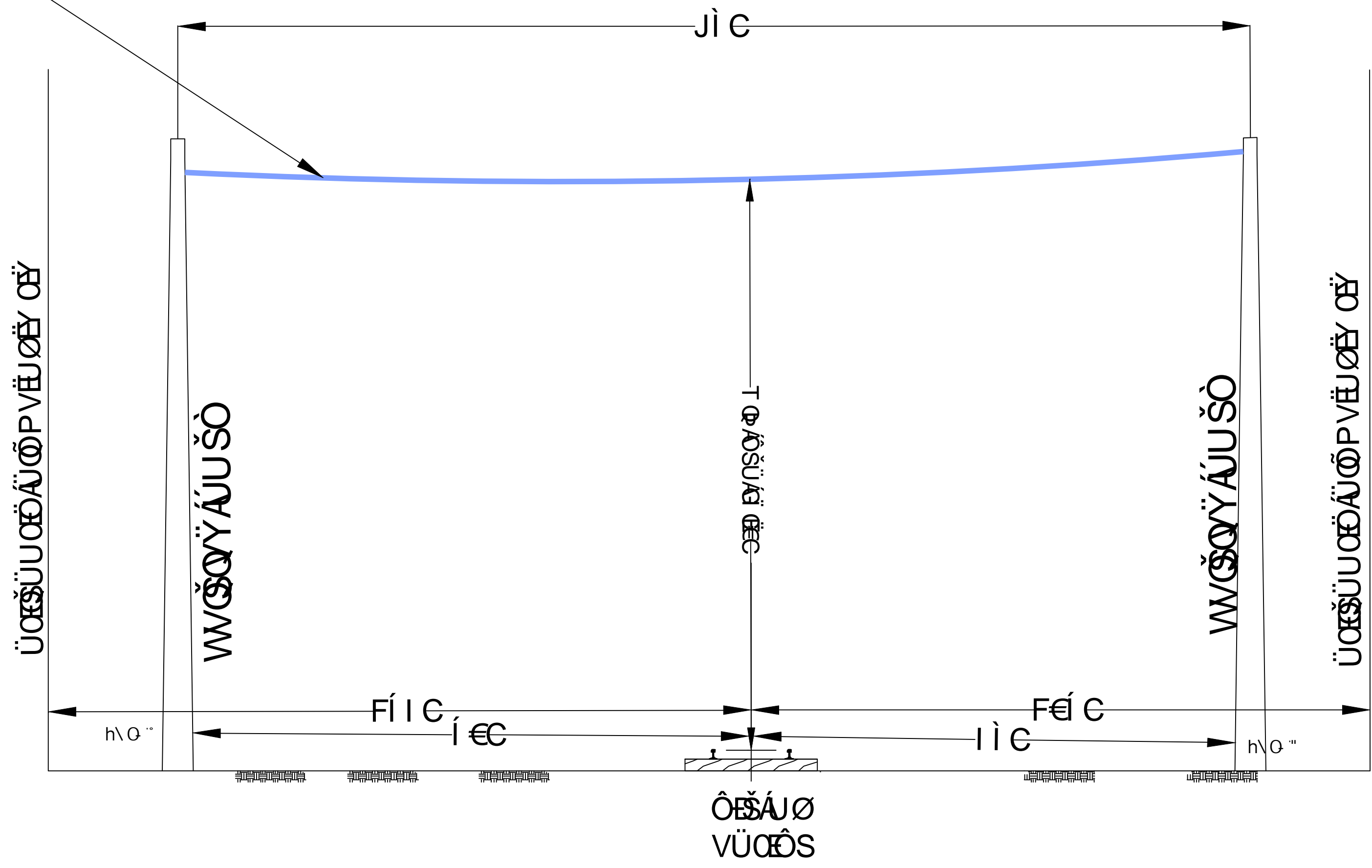

ÚÒP P ÙÿŠX@P QÁUUY ÒÜ
 Í É I Í È I JGFÍ
 OÈ/VO@P Á@V/K@ CÄ
 ŠOÈ/KÁ FÈ JÍ I Í É I
 ŠUPŒKÄ Í È H I GJJ

F5=@FC58'7FCGG-B ; '59F=5@
7@95F5B79'fIG5@9A'GH'@CC?=B ; 'BCFH<L

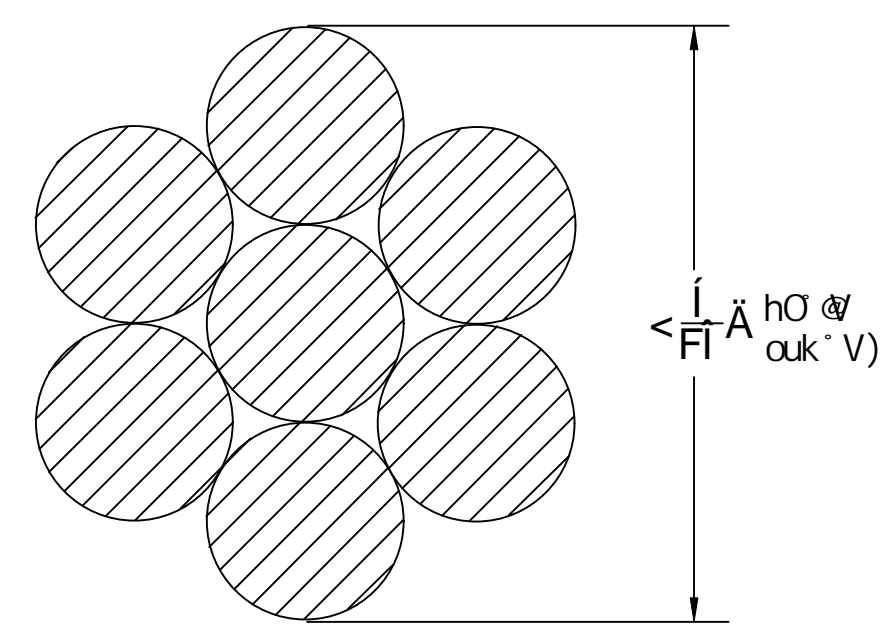

5% DC@9'5'HC'6
 GWY. '% (

u' h# O) - u' ②	o-- - uV\
hk\K#uV' U -	
\k②O' u- U	- \ 7
)k' ‡ ②8V' U -	- t'yQ) - u' ②

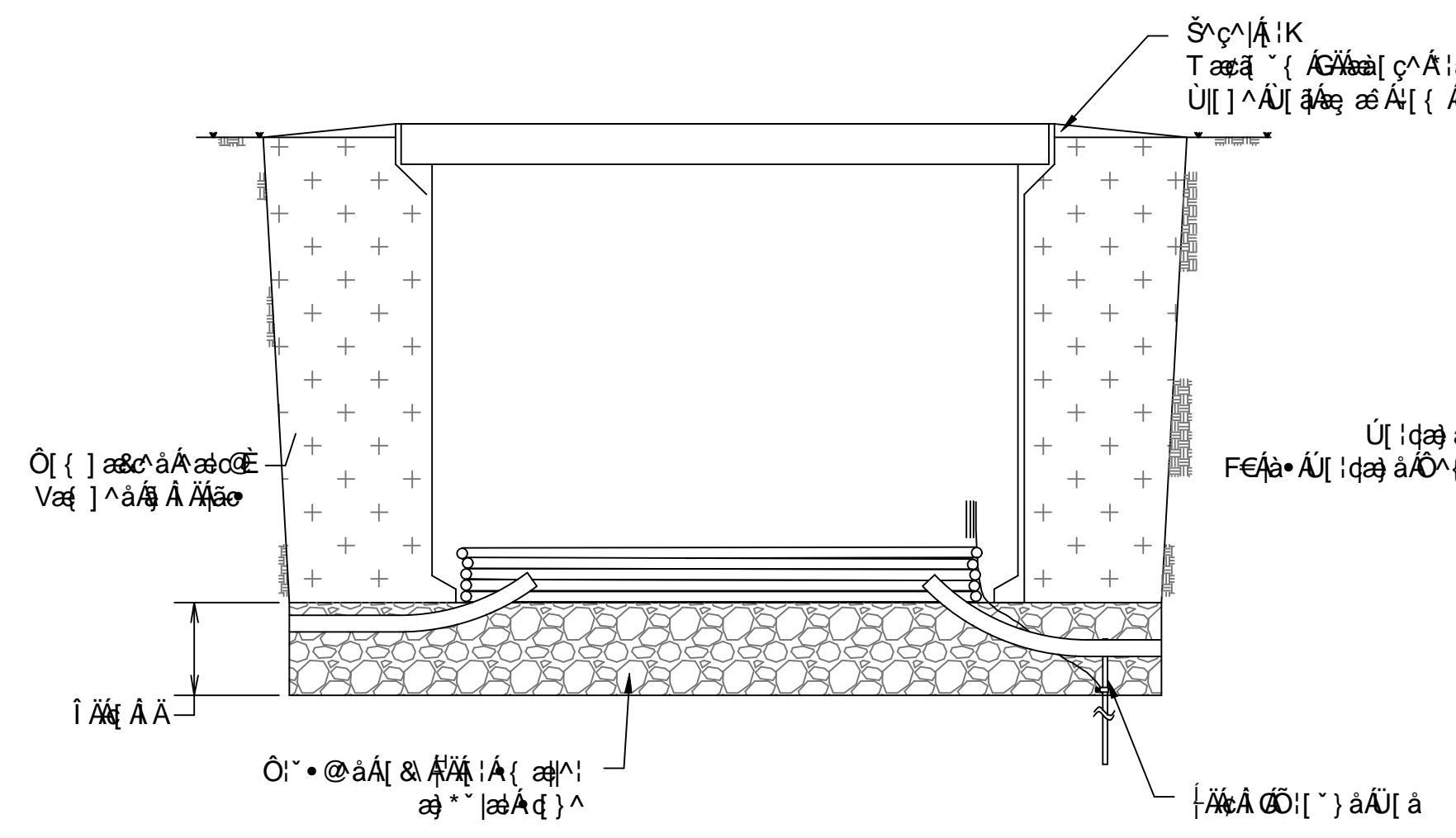
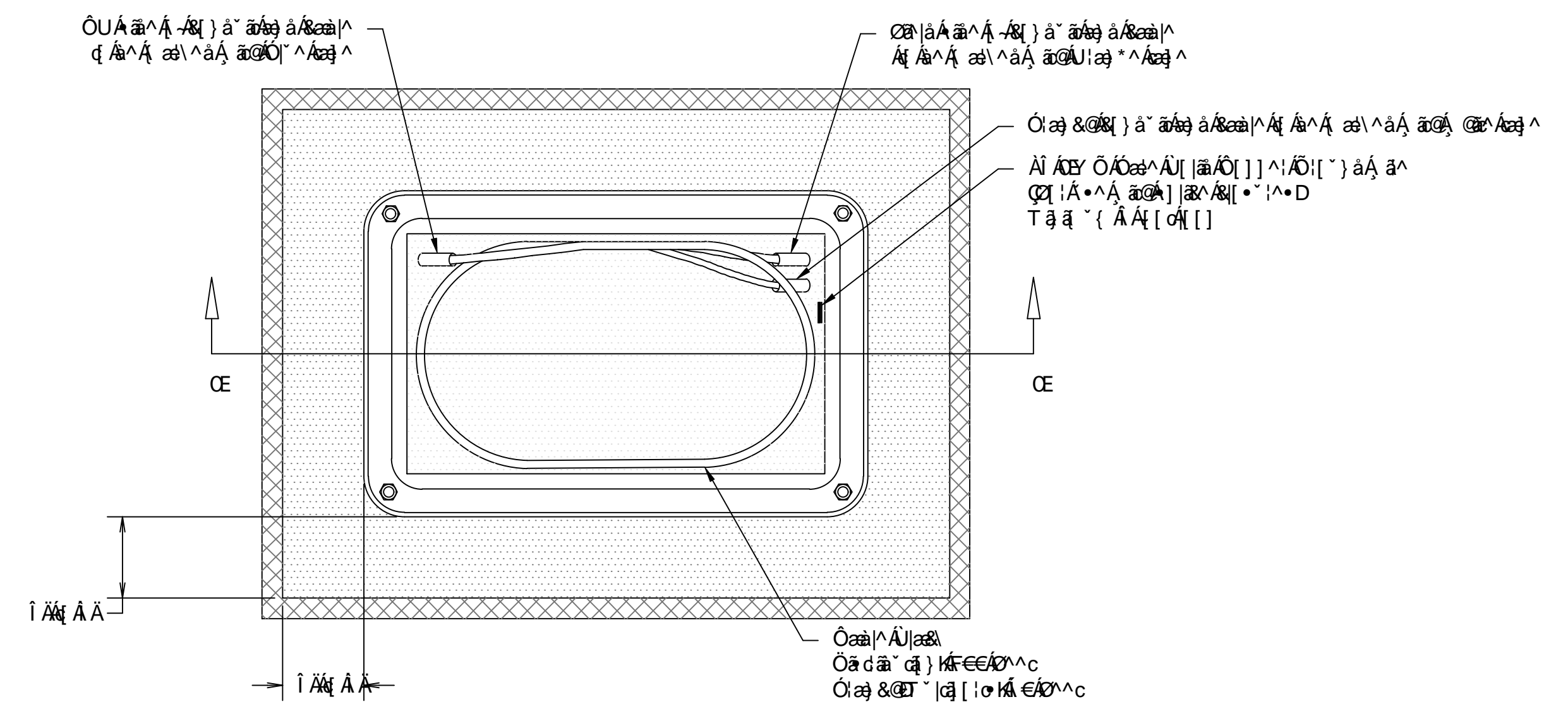

Ó!^ ^ } , áé ÁÁ • ááááá }

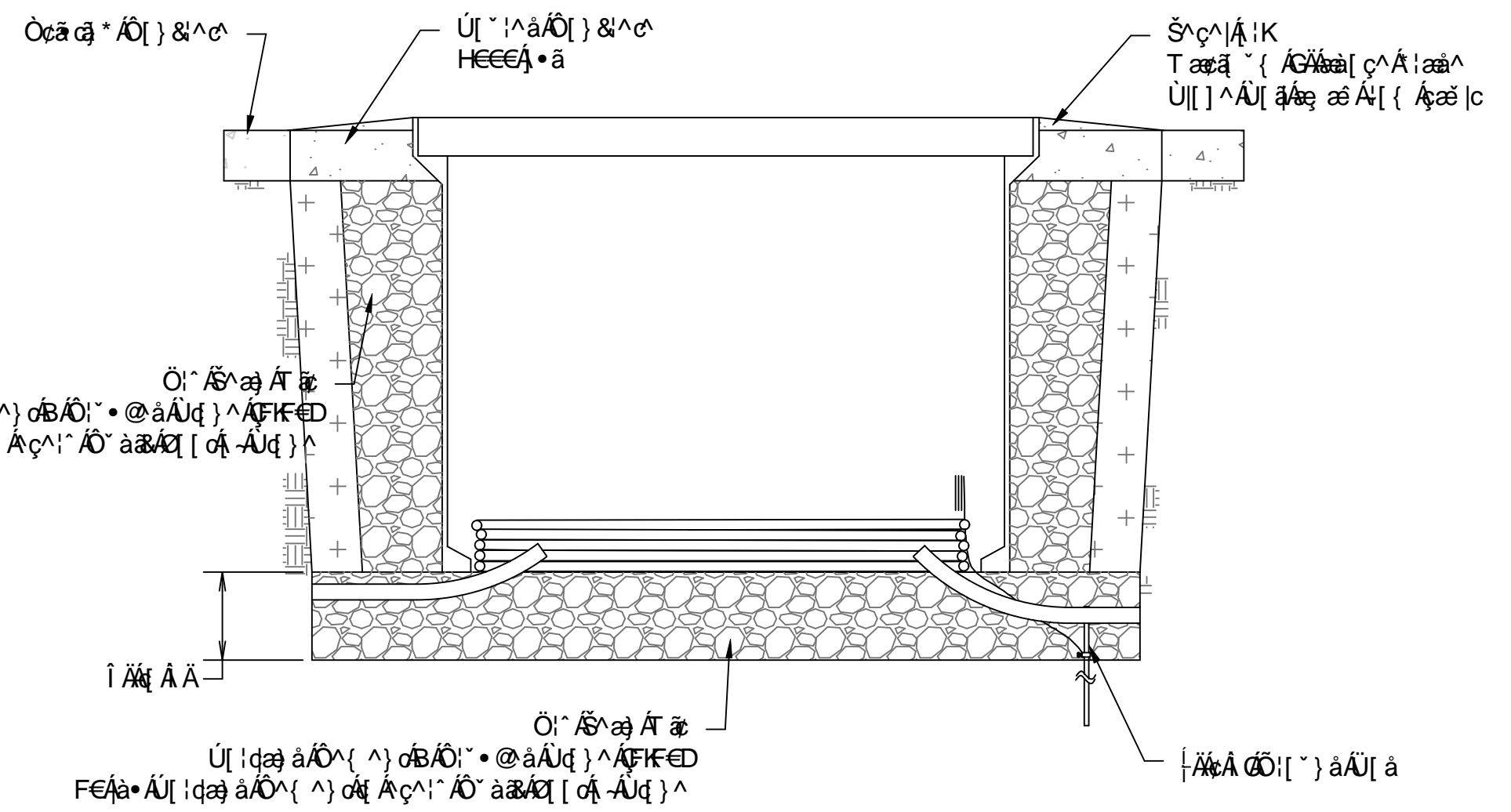

Úáá { ^ } áé ! ÁÁ [] & ^ á ÁÁ • ááááá }

