

# Morgan Lewis

**Catherine G. Vasudevan**  
catherine.vasudevan@morganlewis.com

March 31, 2026

**CONFIDENTIAL TREATMENT REQUESTED**

**Via E-Filing and Overnight Courier**

Matthew L. Homsher, Secretary  
Pennsylvania Public Utility Commission  
Commonwealth Keystone Building  
400 North Street  
Harrisburg, PA 17120

RECEIVED

MAR 31 2026

PA PUBLIC UTILITY COMMISSION  
SECRETARY'S BUREAU

**Re: S-2026-\_\_\_\_\_**  
**Abbreviated Securities Certificate of Fiber AssetCo LLC and Fiber FinCo, LLC**

Dear Secretary Homsher:

Fiber AssetCo LLC ("Fiber AssetCo") and Fiber FinCo, LLC ("Fiber FinCo" and together with Fiber AssetCo, the "Parties"), pursuant to Section 1901 of the Pennsylvania Public Utility Code, 66 Pa. C.S. § 1901, and Section 3.602 of the regulations of the Pennsylvania Public Utility Commission ("Commission"), 52 Pa. Code § 3.602, file this Abbreviated Securities Certificate requesting that the Commission issue a Notice of Registration authorizing Fiber AssetCo to participate in certain Financing Arrangements (as defined below) in connection with an indirect transfer of control of Fiber AssetCo to Fiber FinCo.<sup>1</sup>

The Parties respectfully submit that Fiber AssetCo's participation in the Financing Arrangements qualifies for abbreviated treatment under Section 3.602(a)(3)(ii) of the Commission's regulations, 52 Pa. Code § 3.602(a)(3)(ii). Specifically, as a newly formed company not yet operating in Pennsylvania, Fiber AssetCo's total gross operating revenue received from intrastate telecommunications services rendered in Pennsylvania constituted less than ten percent (10%) of its total gross operating revenue for fiscal year 2025. The Parties respectfully request that the Commission promptly register this Abbreviated Securities Certificate regarding Fiber AssetCo's participation in the Financing Arrangements and issue a Notice of Registration pursuant to the abbreviated procedure.

Please note that certain information on pages 4 and 5 of this Abbreviated Securities Certificate (the "Confidential Information") has been redacted from the electronic filing. An unredacted paper

---

<sup>1</sup> The Commission approved the indirect transfer of control of Fiber AssetCo to Fiber FinCo in Docket No. A-2025-3055301 on August 21, 2025.

**Morgan, Lewis & Bockius LLP**

2222 Market Street  
Philadelphia, PA 19103-3007  
United States

📞 +1.215.963.5000  
📠 +1.215.963.5001

Matthew L. Homsher, Secretary  
March 31, 2026  
Page 2

copy is being sent to the Commission via overnight courier. The Parties consider the Confidential Information to be confidential as it contains sensitive information regarding the Parties' business operations which is not normally subject to inspection by the public and which, if disclosed, would result in substantial harm to the Parties' competitive position. Therefore, the Parties respectfully request that access to the Confidential Information be limited to the Commissioners and Commission Staff who are involved in the consideration of this Abbreviated Securities Certificate and that the unredacted, confidential version of this Abbreviated Securities Certificate not be posted to any public website or maintained in any public file or public filing room.

In support of this filing, the Parties provide the following information:

### **Background**

This Abbreviated Securities Certificate is being filed in connection with a *Pro Forma* Assignment of certain assets and an indirect Transfer of Control, through which (1) Crown Castle Fiber LLC will assign to Fiber AssetCo certain of its fiber network assets in Pennsylvania, including communications optical fiber, certain customer contracts, rights in third party fibers, and associated telecommunications equipment used to provision services or facilities to the affected customers<sup>2</sup> and (2) Fiber FinCo, an indirect subsidiary of Front Range Intermediate, Inc. ("Zayo Parent"), will subsequently acquire all of the stock in Fiber NewCo LLC ("Fiber NewCo"), the direct parent of Fiber AssetCo<sup>3</sup> (together, the "Transaction"). The Transaction also involves obtaining financing, as described below, to support that fiber network business and operations and for other general corporate purposes. Charts depicting the Transaction are included in **Exhibit A**.

In connection with the Transaction, Fiber AssetCo will participate in certain Financing Arrangements by pledging its assets in support of debt incurred by Fiber FinCo, its indirect parent following the Transaction. Therefore, this Abbreviated Securities Certificate seeks authority for Fiber AssetCo to participate in the Financing Arrangements up to the Aggregate Amount (as defined below).

### **Description of the Parties**

#### **A. Fiber AssetCo LLC ("Fiber AssetCo")**

Fiber AssetCo, a wholly owned subsidiary of Fiber NewCo, is a Delaware limited liability company with a principal office located at 8020 Katy Freeway, Houston, Texas 77024. Fiber NewCo, an indirect wholly owned subsidiary of Crown Castle Operating Company ("CCOC"), is a Delaware limited liability company with a principal office located at 8020 Katy Freeway, Houston, Texas 77024. CCOC is a Delaware corporation and a wholly owned subsidiary of Crown Castle Inc. ("CCI"), a publicly traded Delaware corporation (NYSE: CCI). Since January 1, 2014, CCI has operated as a real estate investment trust ("REIT") for U.S. federal income tax purposes. CCI,

---

<sup>2</sup> The *Pro Forma* Assignment was approved by the Commission in Docket No. A-2025-3055297 on August 21, 2025.

<sup>3</sup> As mentioned above, the indirect Transfer of Control was approved by the Commission in Docket No. A-2025-3055301 on August 21, 2025.

Matthew L. Homsher, Secretary

March 31, 2026

Page 3

through certain of its indirect subsidiaries, owns, operates, leases, or manages approximately 40,000 towers and rooftop sites for wireless communications equipment with a significant presence in the top 100 U.S. markets (CCI and its subsidiaries are collectively referred to as "Crown Castle").

Crown Castle subsidiaries deploy approximately 105,000 small cells nodes and approximately 90,000 route miles of fiber in the United States. These Crown Castle subsidiaries provide transport, backhaul, and small cells services as well as dedicated point-to-point telecommunications services. More information can be found on Crown Castle's website at [www.crowncastle.com](http://www.crowncastle.com).

In Pennsylvania, Fiber AssetCo is authorized as a competitive access provider pursuant to authority granted in Docket No. A-2025-3055237 on July 24, 2025.

### **B. Fiber FinCo, LLC ("Fiber FinCo")**

Fiber FinCo is a Delaware limited liability company with a principal office located at 1401 Wynkoop Street, Suite 500, Denver, Colorado 80202, which was created for the purpose of acquiring CCOC's fiber network business. Fiber FinCo is an indirect, wholly owned subsidiary of Zayo Parent, which is an intermediate parent of Zayo Group, LLC ("Zayo Group"), a Delaware limited liability company (together with Zayo Parent and its subsidiaries referred to herein as "Zayo"). Zayo is ultimately owned by investment funds affiliated with (1) DigitalBridge Group, Inc., a publicly traded Maryland corporation (NYSE: DBRG) and (2) EQT AB, a Swedish alternative investment firm.

Zayo is a U.S. provider of bandwidth infrastructure and interconnection services over regional and metropolitan fiber networks. These services enable customers to manage, operate, and scale their telecommunications and data networks. Zayo Group customers consist primarily of wireless service providers, national and regional communications service providers, media, Internet, and content companies, government agencies, banks, and other bandwidth-intensive enterprises. Zayo Parent does not provide any services and holds no Federal Communications Commission ("FCC") or state PUC authorizations to provide telecommunications services. Zayo Group is authorized to provide competitive local exchange, competitive access, and/or interexchange services in the District of Columbia and every U.S. state except Alaska. In Pennsylvania, Zayo Group is authorized as a competitive local exchange carrier, competitive access provider, a detariffed interexchange toll reseller, and a detariffed interexchange toll facilities-based carrier.<sup>4</sup> In addition, Zayo Network Services, LLC (formerly known as Zayo Northeast, LLC) ("Zayo-NS"), an indirect subsidiary of Zayo Group, is authorized in Pennsylvania as a competitive access provider, granted in Docket No. A-2024-3049106 on April 10, 2025.<sup>5</sup> Zayo Group is also authorized by the FCC to provide domestic (interstate) and international telecommunications services, and Zayo-NS is authorized by the FCC to provide domestic (interstate) telecommunications services

---

<sup>4</sup> See Docket Nos. A-2011-2224412, A-2011-2224413, A-2011-2224414, A-2011-222435, A-2023-3038652, and A-2023-3038653.

<sup>5</sup> The Commission reissued the certificate to reflect the legal name change from Zayo Northeast, LLC to Zayo Network Services, LLC in Docket No. R-2025-3056371 effective July 21, 2025.

Matthew L. Homsher, Secretary  
March 31, 2026  
Page 4

in addition to certain point-to-point wireless services. More information can be found on Zayo's website at [www.zayo.com](http://www.zayo.com).

For the Commission's reference, diagrams depicting the corporate ownership structures of the Parties are included with **Exhibit A**.

### **Designated Contacts**

Questions, correspondence, or other communications concerning this filing should be directed to:

Catherine G. Vasudevan  
PA I.D. No. 210254  
MORGAN, LEWIS & BOCKIUS LLP  
2222 Market Street  
Philadelphia, PA 19103-3007  
Tel: 215-963-5000  
Fax: 215-963-5001  
[catherine.vasudevan@morganlewis.com](mailto:catherine.vasudevan@morganlewis.com)

*With a copy to:*

Edward B. Adams, Jr.  
Executive Vice President and General Counsel  
Crown Castle Inc.  
8020 Katy Freeway  
Houston, TX 77024  
Tel: 713-570-3000  
[teddy.adams@crowncastle.com](mailto:teddy.adams@crowncastle.com)

Russell M. Blau  
Catherine Wang  
Joshua M. Bobeck  
Danielle Burt  
MORGAN, LEWIS & BOCKIUS LLP  
1111 Pennsylvania Ave., N.W.  
Washington, D.C. 20004-2541  
Tel: 202-739-3000  
Fax: 202-739-3001  
[russell.blau@morganlewis.com](mailto:russell.blau@morganlewis.com)  
[catherine.wang@morganlewis.com](mailto:catherine.wang@morganlewis.com)  
[joshua.bobeck@morganlewis.com](mailto:joshua.bobeck@morganlewis.com)  
[danielle.burt@morganlewis.com](mailto:danielle.burt@morganlewis.com)

*and:*

Lauren Lantero  
Zayo Group, LLC  
1401 Wynkoop Street, Suite 500  
Denver, CO 80202  
Tel: 303-381-3239  
[lauren.lantero@zayo.com](mailto:lauren.lantero@zayo.com)

### **Abbreviated Securities Certificate**

Fiber AssetCo seeks Commission approval to participate in existing, new, amended or restated financing arrangements ("Financing Arrangements") up to an aggregate amount of **[BEGIN CONFIDENTIAL]** [REDACTED] **[END CONFIDENTIAL]**. To maintain adequate flexibility to respond to market conditions and requirements and to respond to future expansion, financing and other business opportunities, authority is sought for Fiber AssetCo to participate in Financing Arrangements (including future refinancings thereof) that are generally consistent with the terms outlined below, which would permit, to the extent market conditions may warrant, modifications to the specific structure of the financing in a manner most favorable to Fiber AssetCo or the borrower:

Matthew L. Homsher, Secretary

March 31, 2026

Page 5

**Amount:** [BEGIN CONFIDENTIAL] [REDACTED] [END CONFIDENTIAL] (the "Aggregate Amount").

**Borrower:** It is currently expected that Fiber FinCo will be the borrower under the Financing Arrangements.

**Debt Instruments:** The Financing Arrangements are expected to initially include term loans but may also include one or more of the following debt instruments: notes or debentures (including notes convertible into equity and private notes that may be exchanged for public notes); conventional credit facilities, such as revolving credit facilities and term loans; letters of credit; and bridge loans; or a combination thereof.

**Security:** Some or all of the Financing Arrangements may be secured facilities, which may include a grant of a security interest in the assets of Fiber NewCo and its current and future subsidiaries, including Fiber AssetCo. A portion of the Financing Arrangements may be unsecured facilities. For the secured facilities, the equity of Fiber FinCo and its current and future subsidiaries, including Fiber AssetCo, may be pledged as additional security. Additionally, Fiber FinCo's current and future subsidiaries, including Fiber AssetCo, may provide a guaranty as security in support of the Financing Arrangements.

**Purpose:** The Financing Arrangements may be used for (i) acquisitions, (ii) refinancing then-existing debt, (iii) funding capital to support growth capital needs, including those of Fiber AssetCo, and (iv) providing working capital to fund general corporate purposes.

**Other Provisions:** The interest rates, terms and conditions, maturity dates, and dates of issuance will be determined by market conditions and lenders' requirements at the time of each issuance.

Fiber AssetCo seeks to participate in Financing Arrangements, after the Transaction closes, up to the Aggregate Amount and thereby to incur debt as a guarantor and to pledge its assets as security for Financing Arrangements up to the Aggregate Amount with terms materially consistent with those outlined above.

The Financing Arrangements will serve the public interest in promoting competition among telecommunications carriers by providing Fiber AssetCo with access to financial resources that will allow it to be an effective competitor. The Financing Arrangements are necessary and appropriate, are consistent with the performance by Fiber AssetCo of its services to the public, will not impair its ability to perform such services, and will promote its corporate purposes. The Financing Arrangements will have no adverse impact on the customers of Fiber AssetCo and will not disrupt service or cause customer confusion or inconvenience.

### **Conclusion**

WHEREFORE, the Parties respectfully request that the Commission promptly register this Abbreviated Securities Certificate and issue a Notice of Registration, pursuant to Section 1901 of the Pennsylvania Public Utility Code, 66 Pa. C.S. § 1901, and Section 3.602(c) of the Commission's regulations, 52 Pa. Code § 3.602(c), authorizing Fiber AssetCo to participate in the Financing

Matthew L. Homsher, Secretary  
March 31, 2026  
Page 6

Arrangements up to the Aggregate Amount substantially consistent with the parameters outlined above.

As required by the Commission's rules, a filing fee in the amount of \$25.00 is being paid by credit card through the Commission's electronic filing system.

The Parties would appreciate acknowledgement of receipt and acceptance of this filing. Should you have any questions concerning this Abbreviated Securities Certificate, please contact my colleague Joshua M. Bobeck at [joshua.bobek@morganlewis.com](mailto:joshua.bobek@morganlewis.com).

Respectfully submitted,

/s/ Catherine G. Vasudevan

Catherine G. Vasudevan  
PA I.D. No. 210254  
MORGAN, LEWIS & BOCKIUS.LLP  
2222 Market Street  
Philadelphia, PA 19103-3007  
Tel: 215-963-5000  
Fax: 215-963-5001  
[catherine.vasudevan@morganlewis.com](mailto:catherine.vasudevan@morganlewis.com)

*Counsel to the Parties*

**EXHIBIT A**

**Depiction of the Transaction and Corporate Ownership Structures**

RECEIVED

MAR 31 2026

PA PUBLIC UTILITY COMMISSION  
SECRETARY'S BUREAU

# Pre-Transaction Ownership Structure Charts

**CHART 1**  
**PRE-TRANSACTION OWNERSHIP STRUCTURE OF CROWN CASTLE FIBER LLC\***

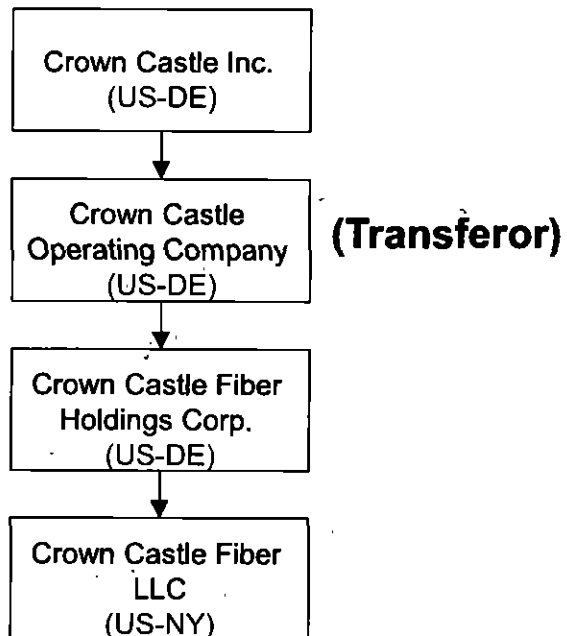

\*All ownership percentages are 100%.

# Post-Crown Castle Restructuring Ownership Structure Chart

**CHART 2**

**POST-RESTRUCTURING OWNERSHIP STRUCTURE OF CROWN CASTLE FIBER LLC\***

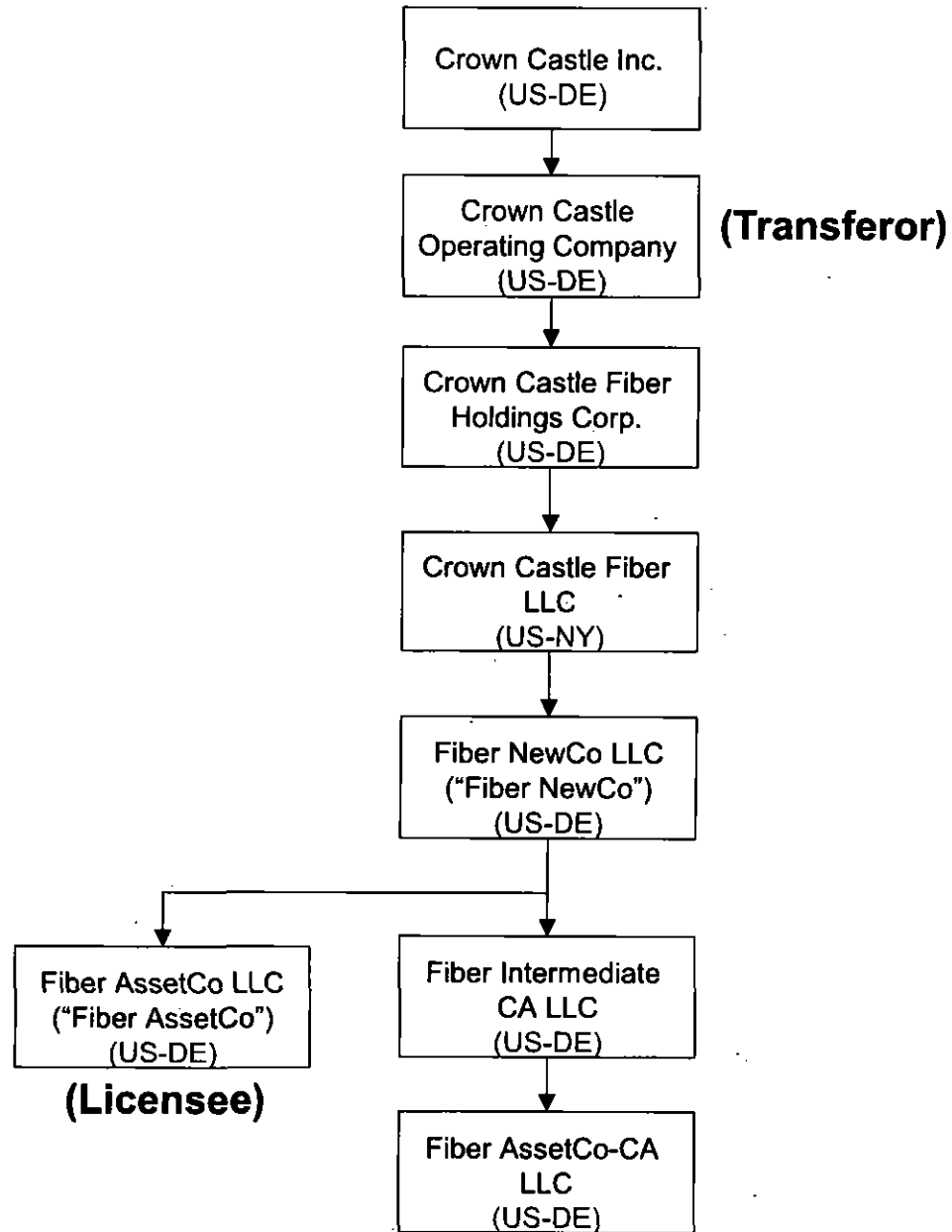

# Post-Transaction Ownership Structure Charts

### CHART 3 EQT AB STRUCTURE

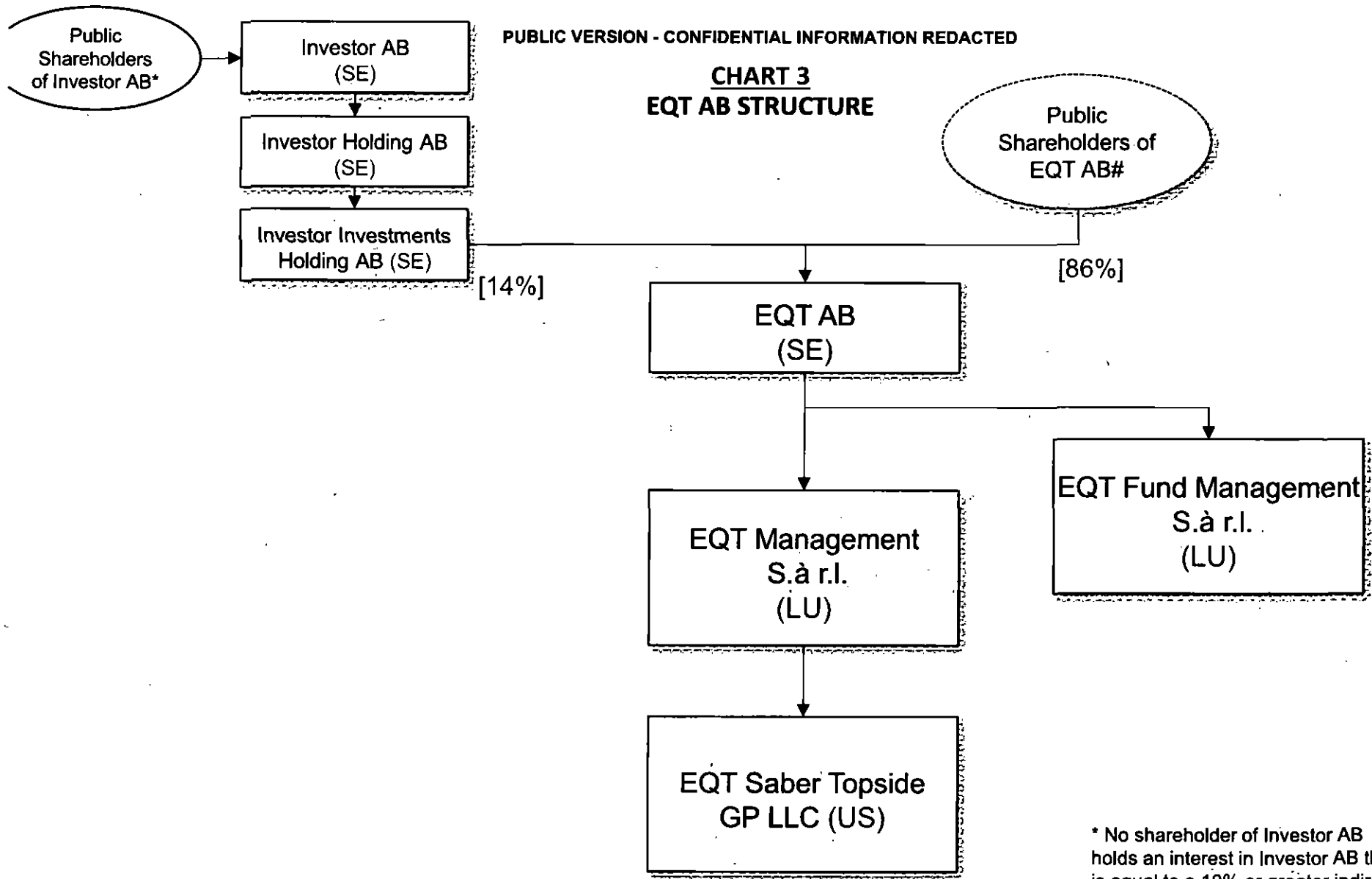

\* No shareholder of Investor AB holds an interest in Investor AB that is equal to a 10% or greater indirect interest in Fiber FinCo LLC.  
# No other shareholder of EQT AB holds an interest in EQT AB that is equal to a 10% or greater indirect interest in Fiber FinCo LLC.

(See Chart 5)

- Economic Ownership
- General Partner

All rights are 100% unless noted otherwise

**CHART 4**  
**DIGITALBRIDGE STRUCTURE**

All rights are 100% unless noted otherwise

\*Omits vehicles for employee Incentives plans/carried Interest

\* No shareholder of DigitalBridge Group Inc. holds an interest in DigitalBridge Group Inc. that is equal to a 10% or greater indirect interest in Fiber FinCo LLC.

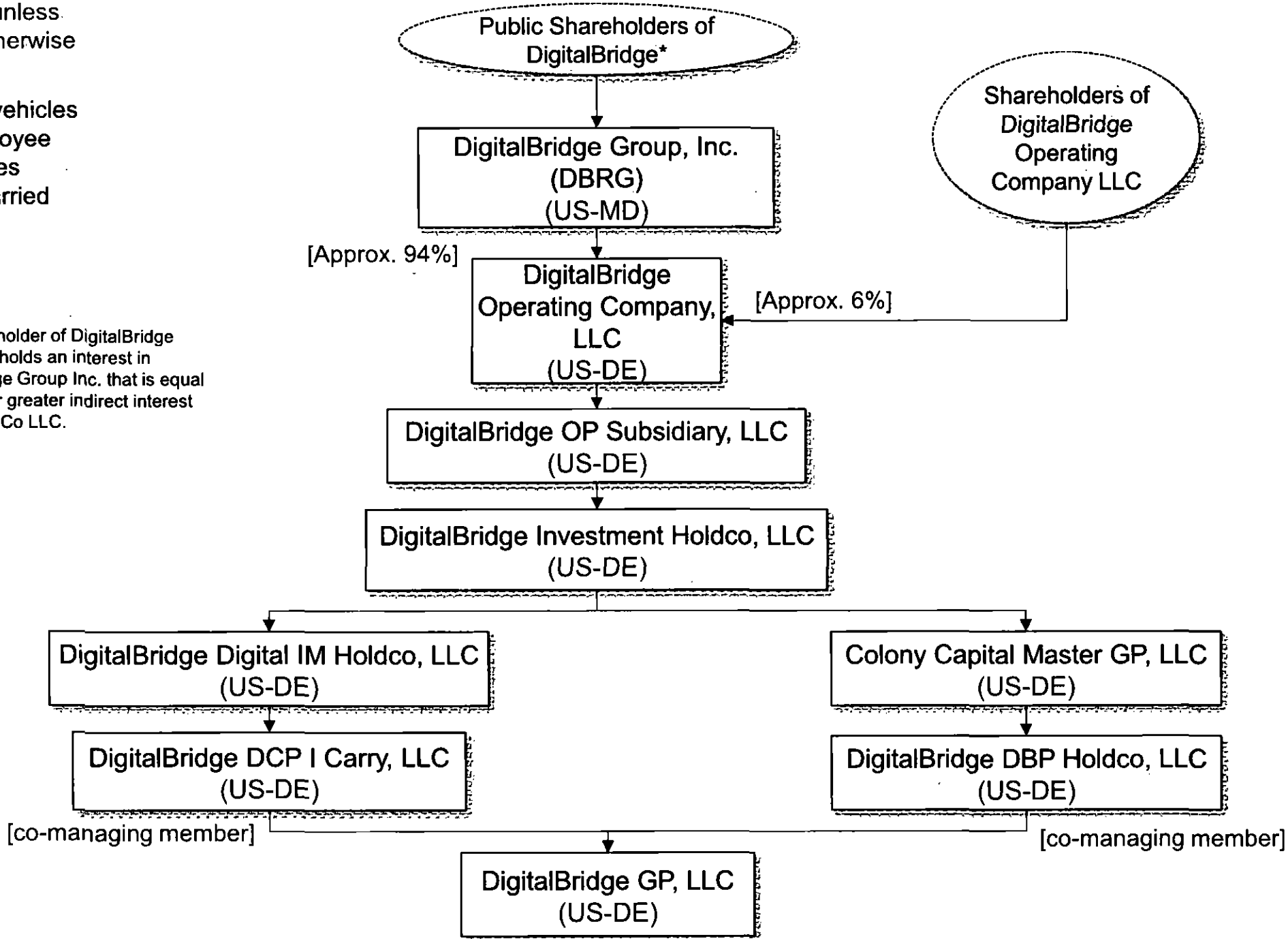

(See Chart 5)

**CHART 5**

**PUBLIC VERSION - CONFIDENTIAL INFORMATION REDACTED**  
(See Chart 3)

**FRONT RANGE JV, LP OWNERSHIP STRUCTURE**

- Limited Partner
- Economic Ownership
- Board Seat/Control
- General Partner

All rights are 100% unless noted otherwise

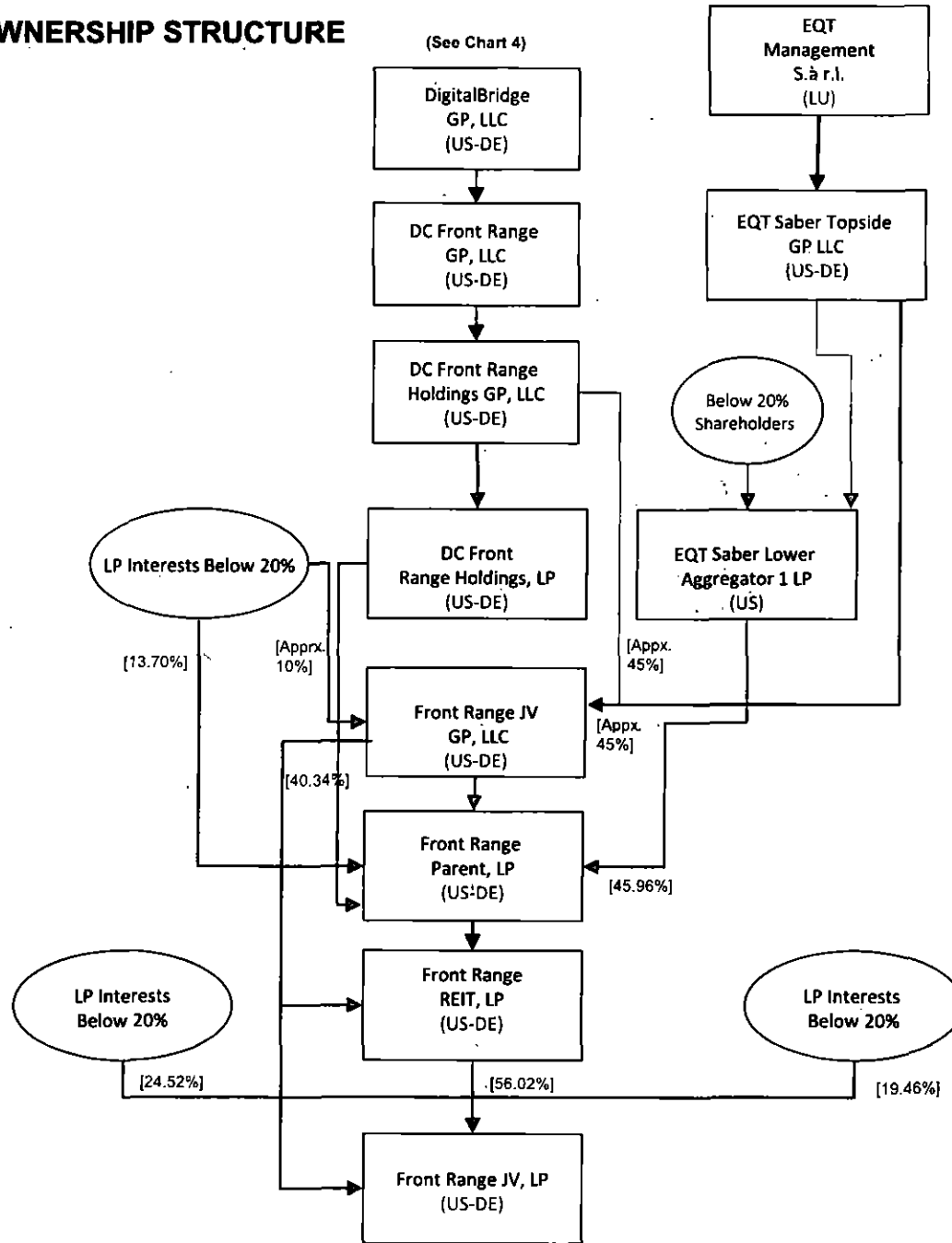

(See Chart 6)

**CHART 6**  
**Post Close Ownership of Fiber NewCo\***

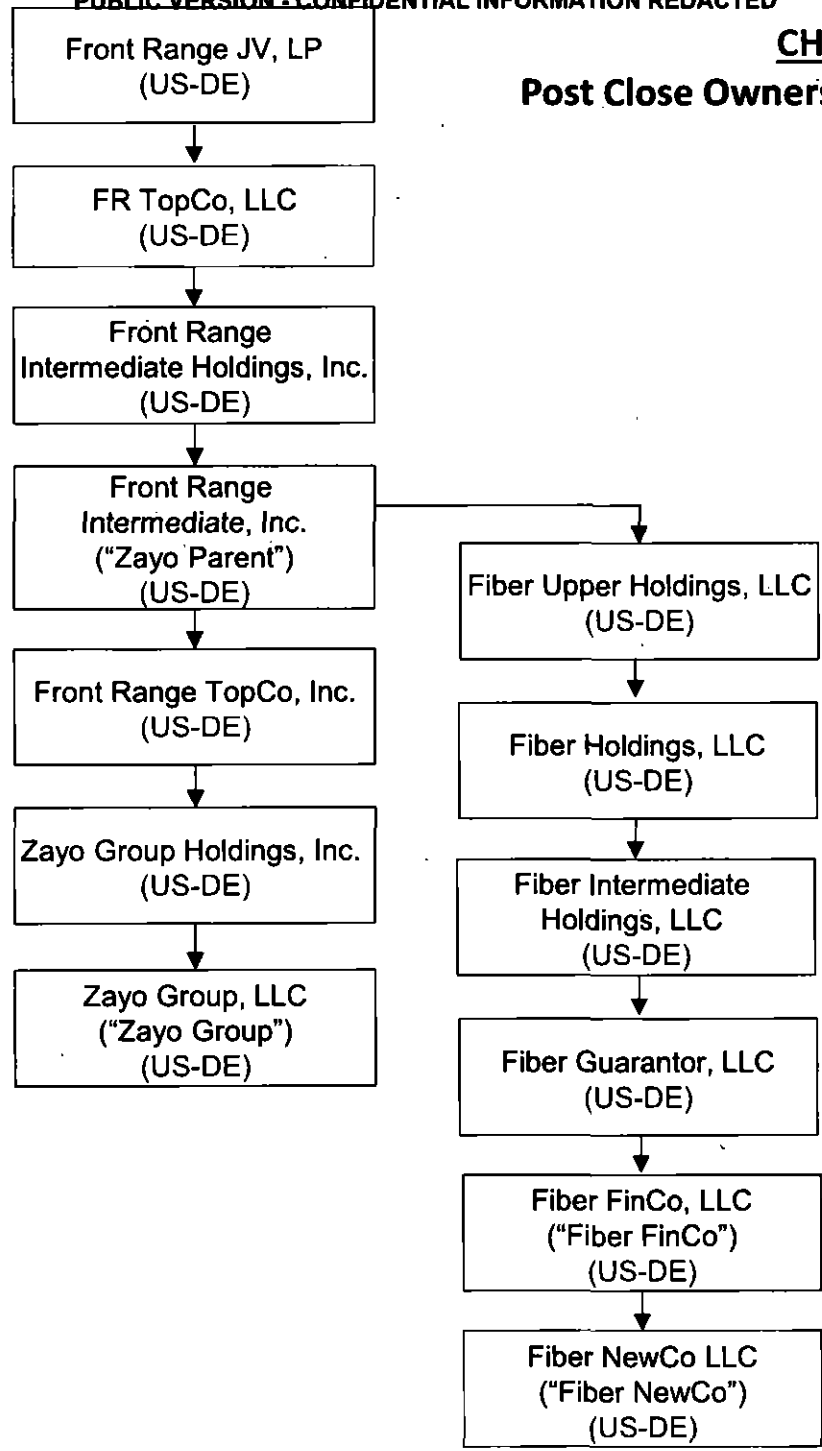

**(Transferee)**

(See Chart 7)

\*All ownership percentages are 100%

\*The entities listed include (i) subsidiaries of Fiber FinCo that currently provide or may in the future provide intrastate, interstate or international telecommunications services in the United States, and (ii) those entities in their ownership chain. The chart excludes all other subsidiaries of Fiber FinCo.

**CHART 7**  
**OWNERSHIP STRUCTURE OF FIBER FINCO LLC\***

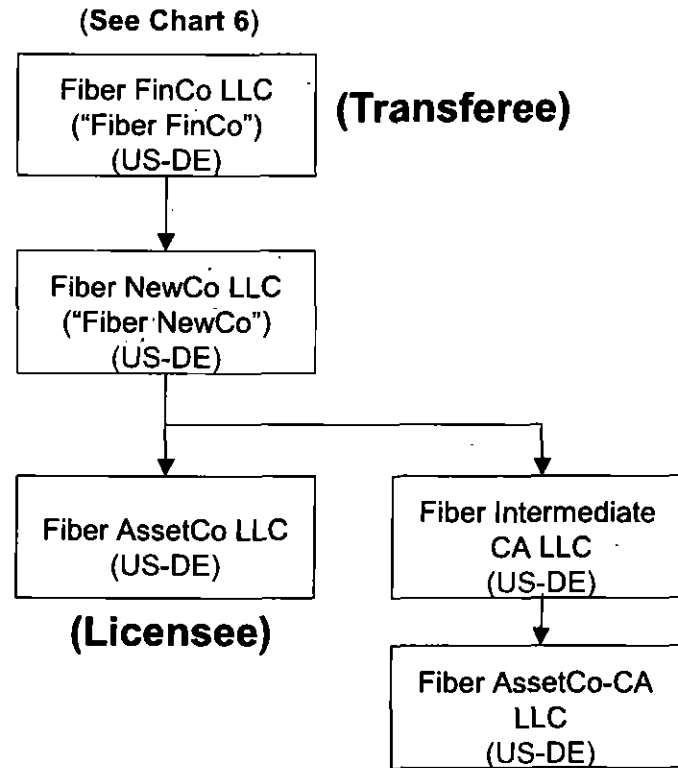

\*\*All ownership percentages are 100%.

**VERIFICATION**

I, Edward B. Adams, Jr., hereby declare that I am Executive Vice President and General Counsel of Crown Castle Inc.; that I am authorized to make this Verification on behalf of Fiber AssetCo LLC (the "Company"); that the foregoing filing was prepared under my direction and supervision; that the contents set forth above with respect to the Company are true and correct to the best of my knowledge, information, and belief; and that I expect to be able to prove the same at a hearing held in this matter. I understand that the statements herein are made subject to the penalties of 18 Pa.C.S. § 4904 (relating to unsworn falsification to authorities).

Dated: March 30, 2026



Edward B. Adams, Jr.  
Executive Vice President and General Counsel  
Crown Castle Inc.

**RECEIVED**

MAR 31 2026

PA PUBLIC UTILITY COMMISSION  
SECRETARY'S BUREAU

**VERIFICATION**

I, Lauren Lantero, hereby declare that I am Chief Legal Officer and Secretary of Fiber FinCo, LLC and Zayo Group, LLC (together, the "Company"); that I am authorized to make this Verification on behalf of the Company; that the foregoing filing was prepared under my direction and supervision; that the contents set forth above with respect to the Company are true and correct to the best of my knowledge, information, and belief; and that I expect to be able to prove the same at a hearing held in this matter. I understand that the statements herein are made subject to the penalties of 18 Pa.C.S. § 4904 (relating to unsworn falsification to authorities).

Dated: March 31, 2026



---

Lauren Lantero  
Chief Legal Officer and Secretary  
Fiber FinCo, LLC and Zayo Group, LLC

**RECEIVED**

**MAR 31 2026**

**PA PUBLIC UTILITY COMMISSION  
SECRETARY'S BUREAU**

**CERTIFICATE OF SERVICE**

I, Micah A. Leval, hereby certify that on this 31<sup>st</sup> day of March 2026, a copy of the foregoing Abbreviated Securities Certificate was served via first class, prepaid postage mail delivery upon the following:

Office of Consumer Advocate  
555 Walnut Street  
5th Floor, Forum Place  
Harrisburg, PA 17101-1923

Office of Small Business Advocate  
Commerce Building, Suite 1102  
555 Walnut Street, 1st Floor – Forum Place  
Harrisburg, PA 17101

Office of Attorney General  
Bureau of Consumer Protection  
15th Floor, Strawberry Square  
Harrisburg, PA 17120

Pennsylvania Public Utility Commission  
Bureau of Investigations and Enforcement  
Commonwealth Keystone Building  
400 North Street, 2<sup>nd</sup> Floor West  
Harrisburg, PA 17120

/s/ Micah A. Leval

Micah A. Leval

3/31/26 10:34 AM