Garrett P. Lent

glent@postschell.com
717-612-6032 Direct
717-731-1985 Direct Fax

June 4, 2026

VIA ELECTRONIC FILING

Matthew Homsher, Secretary
Pennsylvania Public Utility Commission
Commonwealth Keystone Building
400 North Street, Second Floor
Harrisburg, PA 17120

**Re: Joint Letter of Notification of Keystone Appalachian Transmission Company and FirstEnergy Pennsylvania Electric Company for Approval of the Kiski Valley-North Washington 138 Kilovolt Interconnection Project in Washington Township, Westmoreland County, Pennsylvania.
Docket No.**

Dear Secretary Homsher:

Enclosed for filing on behalf of Keystone Appalachian Transmission Company (“KATCo”) and FirstEnergy Pennsylvania Electric Company (“FE PA”) is a Joint Letter of Notification (“LON”), requesting approval for the Kiski Valley-North Washington 138 Kilovolt (“kV”) Interconnection Project (“Project”). This LON is filed pursuant to the Pennsylvania Public Utility Commission’s (“Commission”) regulations at 52 Pa. Code § 57.72(d)(1). Copies of this LON have been served upon the parties as required by 52 Pa. Code § 57.74 and noted on the attached Certificate of Service. We request that one filing fee be counted for both dockets.

Subject to the Commission’s approval, the Project has a scheduled construction date of August 31, 2026, to meet an in-service date of June 9, 2027. To support this construction timeline, KATCo and FE PA respectfully request the Commission’s review and approval of the LON on or before the August 6, 2026, Public Meeting in order to allow construction to commence immediately thereafter.

Matthew Homsher, Secretary
June 4, 2026
Page 2

**REQUEST FOR CONFIDENTIAL TREATMENT
OF PROPRIETY AND NON-PUBLIC INFORMATION**

KATCo and FE PA further note that Attachment A included in this filing contains **CONFIDENTIAL AND PROPRIETARY**, non-public information: Attachment A is designated “**CONFIDENTIAL**” because it contains sensitive information, including commercially sensitive pricing information for certain Project components. In addition, Attachment A has been clearly marked as “**CONFIDENTIAL**” and removed from the public version of the above-captioned Letter of Notification and associated materials and separately filed with the Commission. KATCo and FE PA request that Attachment A be given confidential treatment by the Commission, including its various offices and bureaus. That is, KATCo and FE PA request that Attachment A be excluded from the Commission’s public document folder and that the confidential copies not be disclosed to the public. KATCo and FE PA will provide copies of these materials to parties in this proceeding that have executed appropriate Non-Disclosure Certificates pursuant to a Stipulated Protective Agreement or Protective Order.

If you have any questions pertaining to this matter, please do not hesitate to contact me.

Respectfully submitted,



Garrett P. Lent

GPL/sll
Enclosures

cc: Deb Backer - Bureau of Technical Utility Services
Jordan Van Order - Bureau of Technical Utility Services
Certificate of Service

CERTIFICATE OF SERVICE

I hereby certify that a true and correct copy of the foregoing Letter of Notification has been served upon the following persons, in the manner indicated, in accordance with the requirements of 52 Pa. Code § 57.72(d)(3).

VIA CERTIFIED MAIL: RETURN RECEIPT REQUESTED

Office of Consumer Advocate
555 Walnut Street
5th Floor Forum Place
Harrisburg, PA 17101-1923

Pennsylvania Department of
Conservation and Natural Resources
400 Market St.
Harrisburg, PA 17105

Office of Small Business Advocate
555 Walnut Street,
1st Floor Forum Place
Harrisburg, PA 17101

Pennsylvania Game Commission
2001 Elmerton Ave.
Harrisburg, PA 17110-9797

Pennsylvania Public Utility Commission
Bureau of Investigation and Enforcement
P.O. Box 3265
Harrisburg, PA 17105-3265

Pennsylvania Fish and Boat
Commission
1601 Elmerton Ave.
Harrisburg, PA 17110

Pennsylvania Department of Environmental
Protection
ATTN: Office of Chief Counsel
400 Market St., 9th Floor
Harrisburg, PA 17105
CC: Secretary to PADEP Chief Counsel

US Fish and Wildlife Service
Pennsylvania Field Office
110 Radnor Road, Suite 101
State College, PA 16801-4850

Pennsylvania Department of Environmental
Protection
ATTN: Bureau of Waterways Engineering
and Wetlands
400 Market Street
Harrisburg, PA 17101

Andrea Lowery – Executive Director
Pennsylvania Historical & Museum
Commission
300 North Street
Harrisburg, PA 17120-0024

Office of Chief Counsel
Real Property Division
Pennsylvania Department of Transportation
Commonwealth Keystone Building
400 North Street, 9th Floor
Harrisburg, PA 17120

Sean Kertes – Chair
Westmoreland County
Commissioner
2 N. Main St. Suite 101
Greensburg, PA 15601

Douglas W. Chew – Vice Chair
Westmoreland County
Commissioner
2 N. Main St. Suite 101
Greensburg, PA 15601

Ted Kopas – Secretary
Westmoreland County Commissioner
2 N. Main St. Suite 101
Greensburg, PA 15601

Jared M. Squires – Treasurer
Westmoreland County
2 N. Main St. Suite 110
Greensburg, PA 15601

Rob Cronauer – District Manager/CEO
Westmoreland County Conservation District
J. Roy Houston Conservation Center
218 Donohoe Road
Greensburg, PA 15601

Richard Gardner – Chairman
Supervisor Board
Washington Township
285 Pine Run Church Road
Apollo, PA 15613

Joseph Olszewski – Vice-Chairman
Supervisor Board
Washington Township
285 Pine Run Church Road
Apollo, PA 15613

Matt Thornton – Member
Supervisor Board
Washington Township
285 Pine Run Church Road
Apollo, PA 15613

Date: June 4, 2026

Jason Rigone – Executive Director
Westmoreland County
Planning Commission
40 N. Pennsylvania Ave
5th Floor, Suite 520
Greensburg, PA 15601

CNX Resources Corporation
1000 Horizon Vue Dr.
Canonsburg, PA 15317

Mummert Robert Etal
4484 State Route 66
Apollo, PA 15613



Garrett P. Lent

**BEFORE THE
PENNSYLVANIA PUBLIC UTILITY COMMISSION**

**JOINT LETTER OF NOTIFICATION
OF KEYSTONE APPALACHIAN
TRANSMISSION COMPANY AND
FIRSTENERGY PENNSYLVANIA
ELECTRIC COMPANY FOR
APPROVAL OF THE KISKI
VALLEY–NORTH WASHINGTON 138
KILOVOLT INTERCONNECTION
PROJECT IN WASHINGTON
TOWNSHIP, WESTMORELAND
COUNTY, PENNSYLVANIA**

:
:
:
:
: Docket No. _____
:
:
:
:
:
:
:
:
:
:
:

JOINT LETTER OF NOTIFICATION

TO THE PENNSYLVANIA PUBLIC UTILITY COMMISSION:

Pursuant to 52 Pa. Code § 57.72(d)(1)(iii) and (d)(1)(vi), Keystone Appalachian Transmission Company (“KATCo”) and FirstEnergy Pennsylvania Electric Company (“FE PA”) (together, the “Companies”) submit this Joint Letter of Notification requesting approval from the Pennsylvania Public Utility Commission (“Commission”) to site and construct a transmission line tap from the existing Kiski Valley–North Washington 138 Kilovolt (“kV”) Transmission Line to the new customer-owned Strawberry Substation (“Kiski Valley–North Washington 138 kV Interconnection Project” or “Project”) in Washington Township, Westmoreland County, Pennsylvania.

The proposed Project was developed to provide a new 138 kV retail delivery point to CNX Gas Company, LLC (“Customer”). The Customer requested the proposed delivery point for

electric service to its new Strawberry Substation. The Project will consist of tapping the existing Kiski Valley–North Washington 138 kV Transmission Line by constructing approximately 0.04 miles of 138 kV transmission line. As described in detail below, KATCo will own and operate the facilities that are being replaced along the Kiski Valley–North Washington 138 kV Transmission Line. FE PA will own and operate the new transmission line tap, including all conductor and structures between the KATCo and FE PA point of interconnection and the FE PA and Customer point of interconnection. KATCo will provide transmission service to FE PA, and FE PA will provide distribution service to the Customer. The total estimated cost of this Project, as detailed below, is approximately \$2,818,000.

The Project will be constructed in Washington Township, Westmoreland County, Pennsylvania. The Companies have provided information regarding this Project to all identified political subdivisions, and none of them have objected to the Project. Subject to the Commission’s approval, construction on the Project is scheduled to begin on August 31, 2026, to meet an in-service date of June 9, 2027. To support this construction timeline, the Companies respectfully request that the Commission issue its final ruling no later than the Public Meeting scheduled for August 6, 2026.

In support thereof, the Companies submit as follows:

I INTRODUCTION

1. KATCo is a “public utility” as defined by Section 102 of the Public Utility Code. *See* 66 Pa.C.S. § 102. KATCo exclusively provides interstate electric transmission service in the Commonwealth of Pennsylvania.
2. FE PA is a “public utility” and an “electric distribution company” as defined in Sections 102 and 2803 of the Pennsylvania Public Utility Code, 66 Pa.C.S. §§ 102, 2803.
3. KATCo and FE PA are wholly owned subsidiaries of FirstEnergy Corp..

4. KATCo and FE PA are public utilities subject to the jurisdiction of the Commission over the siting and construction of transmission lines pursuant to Chapter 57, Subchapter G, of the Commission's regulations.

5. The addresses of KATCo's and FE PA's principal business office are:

Keystone Appalachian
Transmission Company
341 White Pond Drive
Akron, OH 44320

FirstEnergy Pennsylvania
Electric Company
800 Cabin Hill Drive
Greensburg, PA 15601

6. The attorneys representing KATCo and FE PA in this matter, authorized to receive notices and communications on its behalf, are:

Tori Giesler (ID #207742)
FirstEnergy Service Company
341 White Pond Drive
Akron, OH 44320
Phone: (717) 490-3292
E-mail: tgiesler@firstenergycorp.com

David B. MacGregor (ID #28804)
Garrett P. Lent (ID #321566)
Megan Rulli (ID # 331981)
Post & Schell, P.C.
17 North Second Street
12th Floor
Harrisburg, PA 17101-1601
Phone: (717) 731-1970
E-mail: dmacgregor@postschell.com
glent@PostSchell.com
mrulli@postschell.com

Emily S. Greco (ID #337777)
Post & Schell, P.C.
One Oxford Centre
301 Grant Street, Suite 3010
Pittsburgh, PA 15219
Phone: (412) 506-6368
Fax: (412) 227-9065
E-mail: egreco@postschell.com

KATCo and FE PA agree to accept electronic service in this proceeding.

7. KATCo and FE PA also request that a copy of all notices and communications regarding this matter be sent to:

Anthony Oberhauser
Transmission Specialist II
FirstEnergy Service Company
341 White Pond Drive
Akron, OH 44320
Phone: (330) 384-5188
E-mail: aoberhauser@firstenergycorp.com

8. The Companies provide the following attached exhibits in support of this Letter of Notification:

- **Exhibit 1:** A topographic map depicting the location of the proposed Project;
- **Exhibit 2:** A depiction of the general layout of the Project;
- **Exhibit 3:** A copy of the PJM Interconnection, LLC (“PJM”) Attachment M-3 Process Solutions Slides;
- **Exhibit 4:** A depiction of a 138 kV single circuit steel deadend structure (#50);
- **Exhibit 5:** A depiction of a 138 kV single circuit steel monopole; supervisory control and data acquisition (“SCADA”) switch structure (#49A, #50A, #50-1);
- **Exhibit 6:** A depiction of a 138 kV single circuit steel deadend structure (#50-2);
- **Exhibit 7:** A copy of the Wetland and Stream Report prepared by GAI Consultants, Inc. (“GAI”), dated December 3, 2025;
- **Exhibit 8:** A copy of the Pennsylvania Natural Diversity Inventory (“PNDI”) review dated December 12, 2025, and agency clearance correspondence with the Pennsylvania Game Commission (“PGC”), Pennsylvania Department of Conservation and Natural Resources (“DCNR”), Pennsylvania Fish and Boat Commission (“PFBC”), and U.S. Fish and Wildlife Service (“USFWS”), as well as copies of the USFWS concurrence letters for the Indiana Bat, Northern Long-eared Bat, and Tricolored Bat, dated December 12, 2025; and
- **Exhibit 9:** A copy of the Pennsylvania State Historic Preservation Office (“SHPO”) Clearance letter dated January 27, 2026.

9. This Joint Letter of Notification and accompanying exhibits, which are incorporated herein by reference, contain all the information required by 52 Pa. Code § 57.72(d)(4).

II. THE PROJECT

A. NEED FOR THE PROJECT

10. As explained in further detail below, the proposed Project is needed to provide a new 138 kV retail delivery point to the Customer.

11. KATCo, as a transmission owner and as a public utility, has a responsibility to provide transmission assets and maintain them in a manner that is safe, reliable, and resilient to meet the needs of the electric system and the service expectations of its customers. To meet this duty, KATCo applies its transmission asset management planning procedure, which includes system performance and condition assessments. These performance and condition assessments identify system needs and prioritize projects based on several variables such as equipment age, condition, maintenance schedule, and impact on system reliability and performance to ensure a reliable electric grid and reasonable service to its customers.

12. FE PA, as a public utility, has a general right and obligation to serve customers in its service territory, subject to the terms and conditions of its certificate of public convenience.

Specifically, under Section 1501 of the Public Utility Code, FE PA:

shall furnish and maintain adequate, efficient, safe, and reasonable service and facilities, and shall make all such repairs, changes, alterations, substitutions, extensions, and improvements in or to such service and facilities as shall be necessary or proper for the accommodation, convenience, and safety of its patrons, employees, and the public.

66 Pa.C.S. § 1501 (emphasis added); *see also id.* § 1103(a). Section 2802(12) of the Public Utility Code further emphasizes that “[r]eliable electric service is of the utmost importance to the health, safety and welfare of the citizens of the Commonwealth. Electric industry restructuring should ensure the reliability of the interconnected electric system by maintaining the efficiency of the

transmission and distribution system.” *Id.* § 2802(12). Pennsylvania appellate courts and the Commission have further confirmed this obligation to serve.¹

13. FE PA also has a duty to make line extensions in its service territory, in order to serve customers who request service. 52 Pa. Code § 57.19(b).

1. Existing System

14. The existing Kiski Valley–North Washington 138 kV Transmission Line consists of 954 kcmil 45/7 aluminum conductor steel reinforced (“ACSR”) conductor and 7#9 Alumoweld shield wire. The existing structures in the area of the Project range from approximately 75 to 80 feet tall and are wood two-pole and three-pole structures, supporting the Kiski Valley–North Washington 138 kV Transmission Line.

15. A general layout of the Project is provided in **Exhibit 2**.

2. Identification of Need

16. The proposed Project is needed to provide a new 138 kV retail delivery point to the Customer. The Customer requested the proposed delivery point for electric service to a new substation. The proposed load addition is approximately 9.9 megavolt-amperes. The Project is not part of a larger project and is solely needed to provide the requested new 138 kV retail delivery point.

17. PJM is the regional transmission organization for Pennsylvania and 12 other states, plus the District of Columbia. PJM functions as the regional planning coordinator, transmission planner, and transmission operator to preserve the reliability of the bulk electricity grid under its

¹ See, e.g., *Pa. Gas Co. v. Pub. Serv. Comm’n*, 83 Pa. Super. 557, 565-66 (1924); *Philadelphia Transp. Co. v. Pa. PUC*, 37 A.2d 138, 147 (Pa. Super. 1944); *Application of Leatherstocking Gas Co., LLC, for Approval to Supply Natural Gas Serv. to the Pub. in N. Susquehanna Cnty., in the Twps. of Bridgewater, Forest Lake, Great Bend, Harmony, New Milford, and Oakland, and in the Boroughs of Great Bend, Hallstead, Lanesboro, Montrose, New Milford, Oakland and Susquehanna*, Docket No. A-2011-2275595, 2012 Pa. PUC LEXIS 1391, at *22 (Order entered Aug. 30, 2012).

operational control. The PJM planning process culminates in a PJM board-approved Regional Transmission Expansion Plan (“RTEP”), which identifies the need and timing of transmission system upgrades and enhancements to provide for the operational, economic, and reliability requirements of PJM customers. The RTEP consists of system upgrades produced from one or more of four planning processes: reliability planning, economic planning, interconnection planning, and local planning.

18. The proposed Project is a “Supplemental Project” or upgrade initiated by KATCo, the Transmission Owner (“TO”), as part of PJM’s local planning process, which is governed by Attachment M-3 of the PJM Open Access Transmission Tariff (“OATT”). In accordance with the Attachment M-3 process, the TO provides information regarding the criteria used to plan and identify Supplemental Projects at a PJM Assumptions Meeting. The process for developing Supplemental Projects requires the identification of a system “need” at a meeting of the PJM Subregional RTEP (“SRRTEP”) Committee, which provides an opportunity for industry stakeholders to comment on the project need. Next, there is a “solutions” meeting where a proposed solution to the previously identified need is presented, along with any alternatives that were considered. Stakeholders can provide comments on the proposed solution.

19. In accordance with the PJM OATT, Attachment M-3, the proposed Project was presented at the PJM Subregional Regional Transmission Expansion Plan – Western Need meeting on September 19, 2025, and Solution meeting on October 17, 2025. The Company’s PJM SRRTEP – Western presentation slides are included as **Exhibit 3**.

20. Once PJM completes its do-no-harm analysis of the Project, PJM will assign the Project a supplementer identifier beginning with an “s” followed by a four-digit number. The Supplemental Number for the proposed Project will be provided once it becomes available. Supplemental upgrades are not mandated or directed by PJM; however, the upgrades are necessary

in order to address planning functions not transferred to PJM (*e.g.*, asset management and customer interconnections). These projects reflect the TOs' obligation to serve its local service territory and are grounded in good utility practice.

21. There are no feasible alternatives that were considered when determining the solution for the proposed Project, because the Project is needed to provide retail delivery service to the Customer.

22. The implementation of advanced transmission technologies was considered as part of this Project. Three new SCADA switches will be installed. SCADA switches offer significant advantages over traditional air switches, primarily due to their enhanced remote control, monitoring, and automation capabilities. SCADA systems allow for real-time data collection and analysis, enabling remote monitoring of multiple devices, troubleshooting problems, and even controlling equipment from anywhere. Air switches, while simple, lack these advanced features and are typically manually operated.

B. THE PROPOSED PROJECT

23. In this Project, the Companies propose to create a 0.04-mile (227.9 feet) line tap from the Kiski Valley–North Washington 138 kV Transmission Line to the new Strawberry Substation.

24. The Project will be constructed between existing structure # 49 and the North Washington Substation. To facilitate the construction of the Project, one structure will be replaced and two new structures will be added to the existing Kiski Valley–North Washington 138 kV Transmission Line. Existing structure #50, a three-pole wood structure (approximately 75 feet tall), will be replaced with a single circuit steel monopole on a concrete foundation tap structure (approximately 81 feet tall), as depicted in **Exhibit 4**. In addition to the replacement of existing structure #50, two single circuit steel monopole switch structures (approximately 81 feet tall and

designated as structures #49A and #50A) will be installed in line on each side of structure #50. An additional single circuit steel monopole switch structure (approximately 81 feet tall and designated as structure # 50-1) will be installed immediately to the north of structure #50 and in line with the transmission line tap. A depiction of these switches is shown in **Exhibit 5**. The new switch structures will support new 2000 amp SCADA-controlled switches. The facilities and assets described in this paragraph will be owned and operated by KATCo.

25. To facilitate construction of the transmission line tap to the new customer substation, a single circuit steel pole deadend structure (approximately 66 feet tall and designated as structure #50-2) will be installed, as depicted in **Exhibit 6**. This facility and associated assets will be owned and operated by FE PA. Lastly, one structure will be installed between structure #50-2 and the new Customer-owned substation, which will be owned and operated by the Customer.

26. The Project will require the installation of approximately 0.04 miles (227.9 feet) of new 954 kcmil 45/7 ACSR “Rail” conductor, and two 7#9 Alumoweld shield wires will be installed on structures #50-1 and #50-2 to the Customer-owned pole structure, terminating at the new Customer-owned Strawberry Substation.

27. The existing Kiski Valley–North Washington 138 kV Transmission Line is owned, operated, and maintained by KATCo. The proposed 0.04-mile transmission line tap will be owned by FE PA from structure #50-1 to the new Customer-owned structure outside of the new Customer substation. The Customer-owned structure and new substation will be owned, operated, and maintained by the Customer. The current estimated Project cost is approximately \$2,818,000. This cost includes approximately \$227,000 for engineering, \$626,000 for materials, and \$2,009,000 for construction. KATCo will be responsible for \$1,210,000, and FE PA will be

responsible for \$1,610,000. The Customer will reimburse KATCo and FE PA a total of \$1,580,000. **CONFIDENTIAL Attachment A** contains a detailed breakdown of these costs.

III. HEALTH AND SAFETY

28. The Project will be designed to meet or exceed all requirements of the latest revision of the National Electrical Safety Code (“NESC”) under all operating conditions, as well as current KATCo design criteria, which states that 138 kV transmission lines shall have a designed vertical conductor to ground clearance of 26 feet. This design value exceeds the NESC minimum of 20.7 feet by a margin of 5.3 feet. In general, KATCo clearance criteria exceed the NESC minimums by margins ranging from two to seven feet, depending on the voltage and specific clearance measurement. The maximum operating temperature will be 212 degrees Fahrenheit.

29. The design, construction, and operation of the Project will meet or exceed all applicable safety standards established by the Occupational Safety and Health Administration (“OSHA”). Moreover, the Project will be constructed in accordance with KATCo’s standard construction practices to perform all work safely. All work will be done in accordance with NESC, OSHA, and all other applicable state and federal requirements.

IV. DESCRIPTION OF RIGHT-OF-WAY

30. The proposed Project will be located within new and existing 100-foot-wide rights-of-way (“ROW”). The Kiski Valley–North Washington 138 kV Transmission Line will remain on its existing centerline in the ROW.

31. The transmission line tap will be located within the 0.04 miles of existing and new easements required for the 138 kV overhead transmission line. Structure numbers 49A, 50, and 50A will be in the existing easement. Structure numbers 50-1, 50-2, owned by FE Pennsylvania, and an additional customer-owned structure will exist within the customers new ROW to the customer-owned Strawberry Substation. All required easements have been secured. The proposed

new ROW will impact one parcel. The one replaced structure and four new structures will all be located on parcel 63-05-00-0-222.

V. LAND USE AND ENVIRONMENTAL EVALUATION

32. As explained above, construction of the proposed Project will take place within the existing ROW for the existing Kiski Valley–North Washington 138 kV Transmission Line or in the newly acquired 100-foot-wide ROW.

33. A field review for wetlands and streams in the Project Area was conducted by GAI. **Exhibit 7** is a copy of the Wetland and Stream Report for the Project, dated December 3, 2025. Three palustrine emergent wetlands were identified within the delineation boundary. No environmental features are anticipated to be impacted by Project activities. Existing access roads will be used to the maximum extent practicable, and non-existing roads and work areas are expected to be temporary for the construction associated with the transmission lines and the proposed interconnection tap line. A section of this Project is covered under the Customer’s National Pollutant Discharge Elimination System (“NPDES”) permit, which was approved by the Westmoreland County Conservation District on April 8, 2025. Areas of the Project that fall outside of the Customer’s NPDES permit boundary are anticipated to include less than one acre of earth disturbance and will not require additional permitting by KATCo.

34. The DCNR and the PFBC have stated that no impacts to protected resources are anticipated by the construction of the Project based on their PNDI review dated December 12, 2025. The PGC identified a conservation measure under the jurisdiction of both the PGC and the USFWS and deferred comments to the USFWS. The USFWS requested that the Project be screened through the Information for Planning and Consultation (“IPaC”) tool, which was completed on December 12, 2025, along with the keys for the Indiana Bat, Tricolored Bat, and the

Northern Long-eared Bat. The results stated that the Project will have no effect on these species. Copies of the PNDI receipt and the IPaC coordination are attached as **Exhibit 8**.

35. Initial consultation with the Pennsylvania SHPO was submitted on November 10, 2025. The SHPO's concurrence, stating that the Project will have no effect on above-ground resources or archaeological resources, was received on January 27, 2026, and is attached as **Exhibit 9**.

VI NOTICE

36. The Companies have provided information regarding the Project to representatives of Washington Township and Westmoreland County. These entities have not objected to the proposed Project. Copies of the Letter of Notification will be served upon all state agencies, federal agencies, county agencies, municipalities, and impacted landowners in accordance with 52 Pa. Code § 57.72(d)(3).

VII LETTER OF NOTIFICATION

37. The Companies are proceeding by means of a Letter of Notification, instead of a full Application, pursuant to the Commission's regulations at 52 Pa. Code § 57.72(d)(1)(iii) and (d)(1)(vi).

38. The proposed Project involves the replacement of one structure and the addition of two structures within an existing transmission line ROW, as well as the construction of a 0.04-mile tap line, which includes two additional structures. As such, the proposed Project qualifies for use of a Letter of Notification because it will be a high voltage ("HV") line which is proposed to be located entirely within the applicant's existing transmission line ROW and the property of the sole customer to be served by the line, and the size, character, design or configuration of the proposed HV line does not substantially alter the right-of-way. *See* 52 Pa. Code § 57.72(d)(1)(iii).

In addition, the Project qualifies for a Letter of Notification because it consists of an HV line with a proposed route of two miles or less. *See* 52 Pa. Code § 57.72(d)(1)(vi).

39. This Letter of Notification is filed on the date set forth below. As provided in 52 Pa. Code § 57.72(d)(5), the Commission will review and, by order, approve or disapprove this Letter of Notification. If the Commission approves this Letter of Notification, the proposed Project will be constructed as proposed herein without the formal application process set forth at 52 Pa. Code §§ 57.71, *et seq.*

WHEREFORE, Keystone Appalachian Transmission Company and FirstEnergy Pennsylvania Electric Company respectfully request that the Pennsylvania Public Utility Commission review and approve the Kiski Valley–North Washington 138 kV Interconnection Project in Washington Township, Westmoreland County, Pennsylvania, as explained above and in the exhibits, attached hereto, on or before the Public Meeting scheduled for August 6, 2026.

Tori L. Giesler (ID #207742)
FirstEnergy Service Company
341 White Pond Drive
Akron, OH 44320
Phone: (610) 921-6658
E-mail: tgiesler@firstenergycorp.com

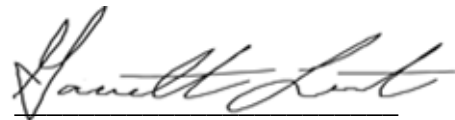

David B. MacGregor (ID #28804)
Garrett P. Lent (ID #321566)
Megan E. Rulli (ID # 331981)
Post & Schell, P.C.
17 North Second Street
12th Floor
Harrisburg, PA 17101-1601
Phone: (717) 731-1970
Fax: (717) 731-1985
E-mail: dmacgregor@postschell.com
glent@postschell.com
mrulli@postschell.com

Emily S. Grecu (ID # 337777)
Post & Schell, P.C.
One Oxford Centre
301 Grant Street, Suite 3010
Pittsburgh, PA 15219
Phone: (412) 506-6368
Fax: (412) 227-9065
E-mail: egrecu@postschell.com

Date: June 4, 2026

Attorneys for Keystone Appalachian
Transmission Company, LLC

EXHIBIT 1

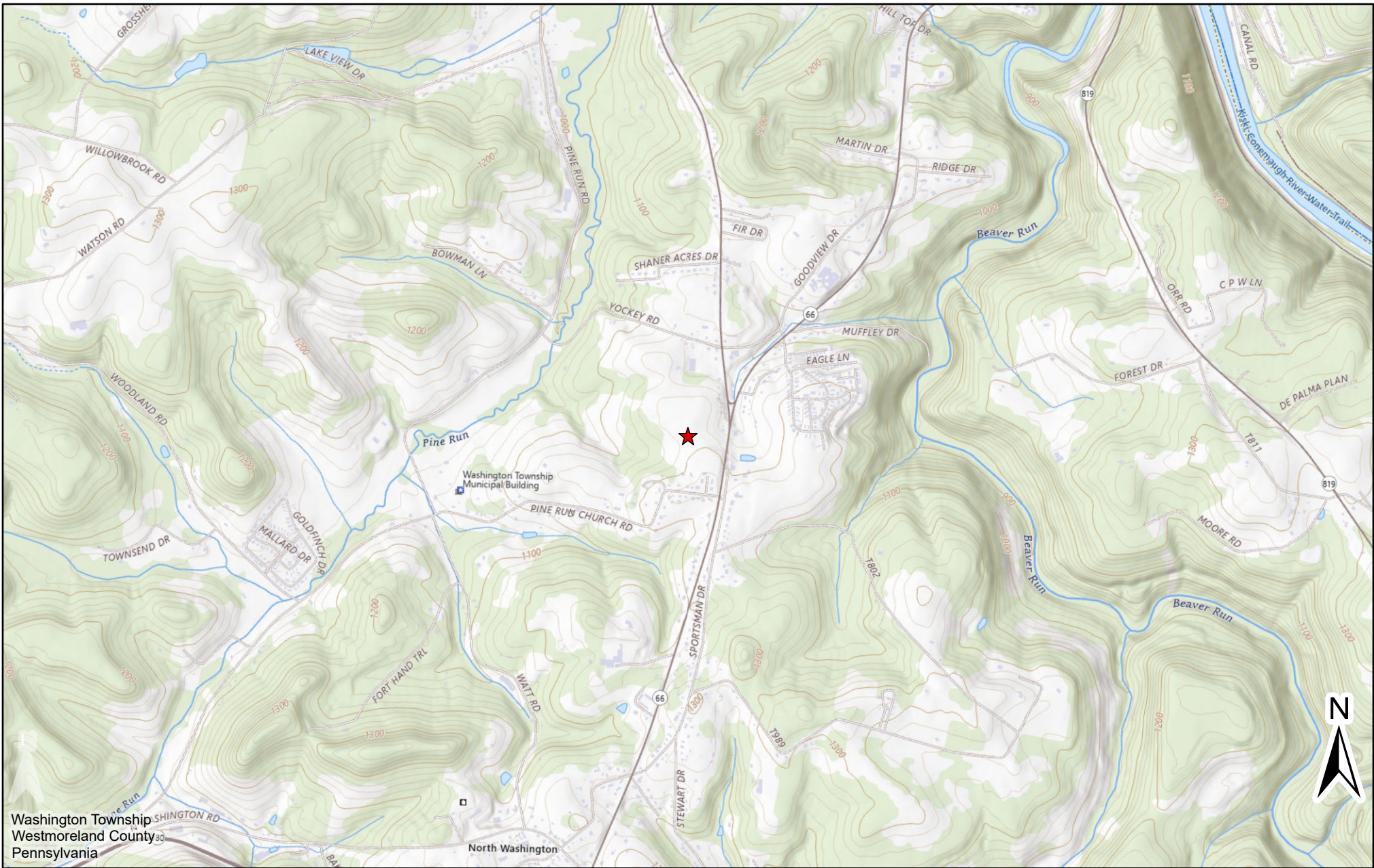

Legend
 ★ Project Location

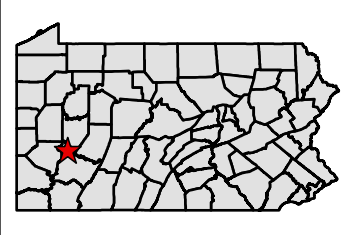

0 1,000 2,000 4,000
 Feet
 Reference Scale: 1:24,000

References:
 ESRI Aerial Imagery, USGS National Map, PennDOT

Coordinate System:
 NAD 1983 StatePlane Pennsylvania South FIPS 3702 Feet

EXHIBIT 1

KATCo
 Keystone Appalachian Transmission Company
 a subsidiary of

**KISKI VALLEY-NORTH WASHINGTON 138kV
 TRANSMISSION LINE INTERCONNECTION PROJECT**

EXHIBIT 2

WESTMORELAND CO, PA



356 PROPERTIES LLC
63-05-00-0-196

MUMMERT ROBERT ETAL
63-05-00-0-222

PINE VUE DR

SR 66

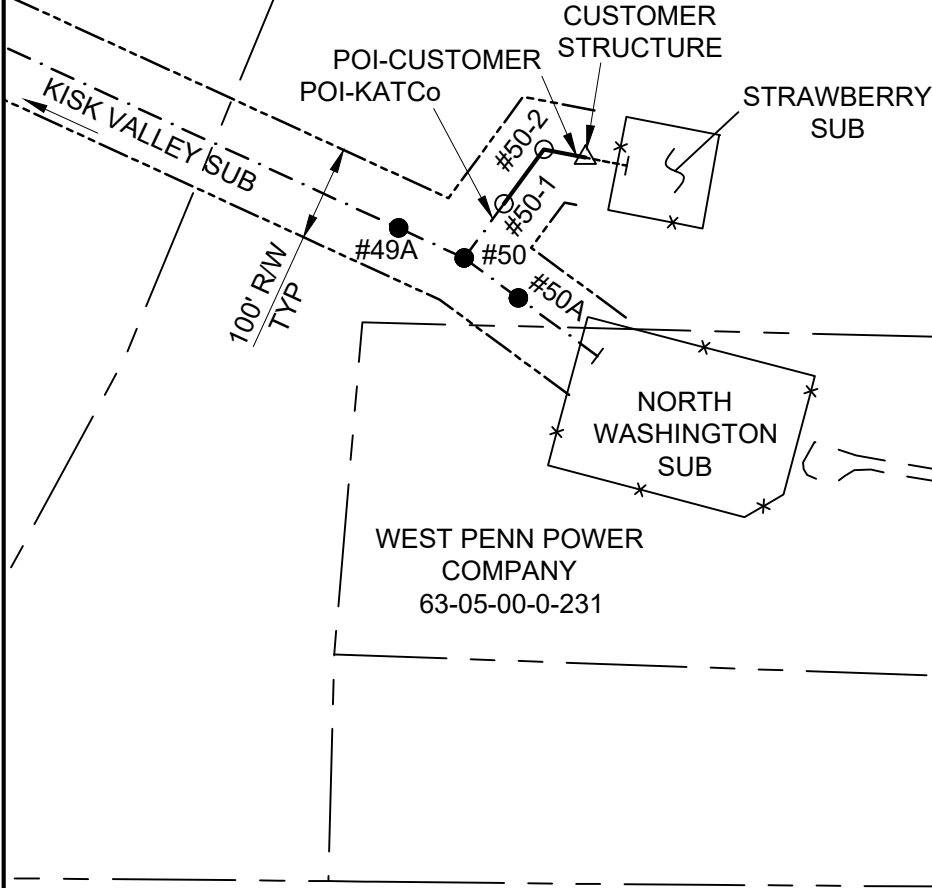

LEGEND

- △ - CUSTOMER PROPOSED STRUCTURE
- - FE PENNSYLVANIA PROPOSED STRUCTURE
- - KATCO PROPOSED STRUCTURE
- - CUSTOMER TRANSMISSION LINE
- . - . - . - KATCO TRANSMISSION LINE
- - FE PENNSYLVANIA ELECTRIC COMPANY (FE PA)
- - PROPERTY LINE



KISKI VALLEY-NORTH WASHINGTON 138KV
TAP TO STRAWBERRY SUBSTATION

GENERAL LAYOUT

EXHIBIT 2

PAPER SIZE: 8.5X11

SCALE: NTS

CE25-246-WP

EXHIBIT 3

APS Transmission Zone M-3 Process Kiski Valley - North Washington 138 kV Line

Need Number: APS-2025-027
Process Stage: Solution Meeting - SRRTEP-W - 10/17/2025
Previously Presented: Need Meeting - SRRTEP-W - 09/19/2024

Project Driver:

Customer Service, Other

Specific Assumption Reference:

FE's Requirements for Transmission Connected Facilities and FE's Transmission Planning Criteria documents

Problem Statement:

New Customer Connection: A new customer has requested a 138 kV delivery point near the existing Kiski Valley - North Washington 138 kV Line.

The requested load is 9.9 MW with a requested in-service date of 6/9/2027. The delivery point is adjacent to North Washington Substation.

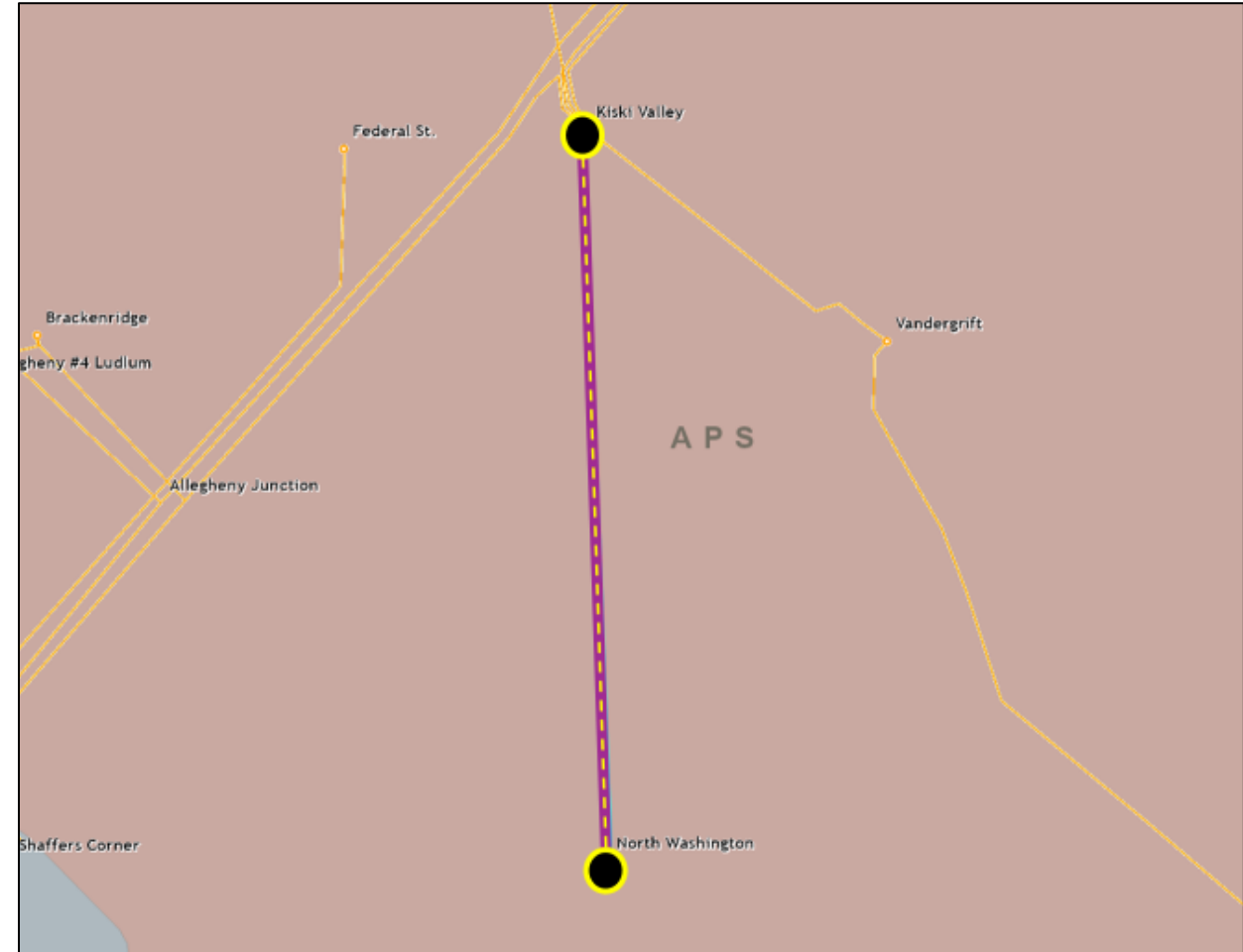

Need Number: APS-2025-027
Process Stage: Solution Meeting - SRRTEP-W - 10/17/2025

Proposed Solution:

Kiski Valley - North Washington 138 kV Line

- Tap the Kiski Valley-North Washington 138 kV Line
- Install three SCADA controlled switches at tap location
- Construct 1-2 spans of transmission line conductor from tap location to customer POI
- Install 138 kV revenue metering within customer substation
- Adjust relay settings at Kiski Valley and North Washington substations

Ratings:

Kiski Valley - Customer Tap 138 kV Line

- After Proposed Solution: 153 / 1 53 / 153 / 153 MVA (SN/SE/WN/WE)

Customer Tap - North Washington 138 kV Line

- After Proposed Solution: 308 / 376 / 349 / 445 MVA (SN/SE/WN/WE))

Alternatives Considered:

No reasonable alternatives were considered due to the customer's proximity to the Kiski Valley - North Washington 138 kV Line.

Estimated Project Cost: \$2.79M
Projected In-Service: 03/27/2030
Project Status: Conceptual
Model: 2024 RTEP - 2029 Summer 50/50 Case

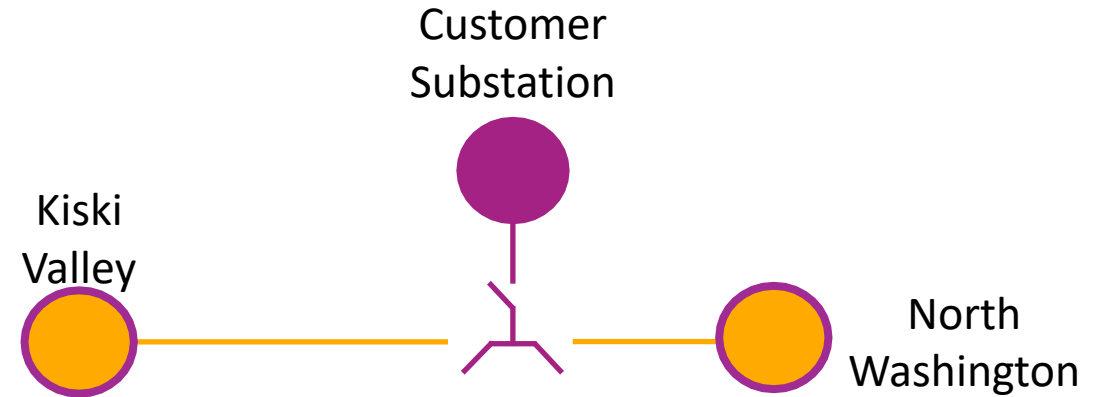

Legend	
500 kV	
345 kV	
230 kV	
138 kV	
115 kV	
69 kV	
46 kV	
34.5 kV	
23 kV	
New	

EXHIBIT 4

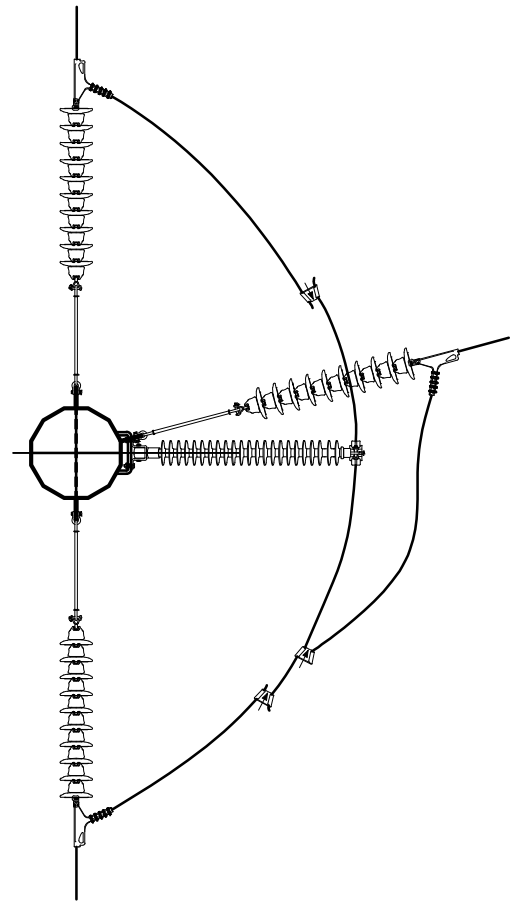
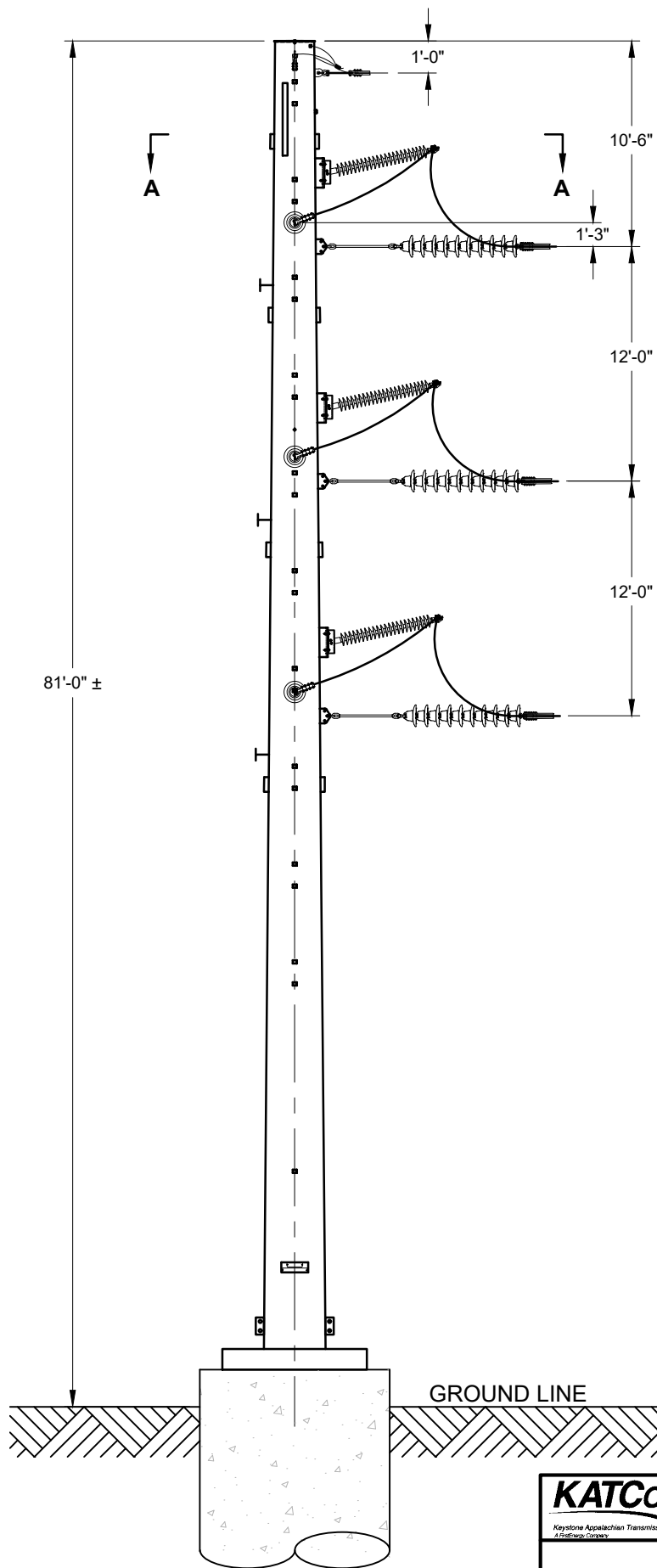

SECTION A-A

STRUCTURE # 50



KISKI VALLEY - NORTH WASHINGTON 138 kV
TRANSMISSION LINE INTERCONNECTION PROJECT

138kV SINGLE CIRCUIT TUBULAR STEEL
TAP STRUCTURE DEADEND SINGLE POLE

EXHIBIT 4

PAPER SIZE: 8.5X11

SCALE: NTS

CE25-246-WP

EXHIBIT 5

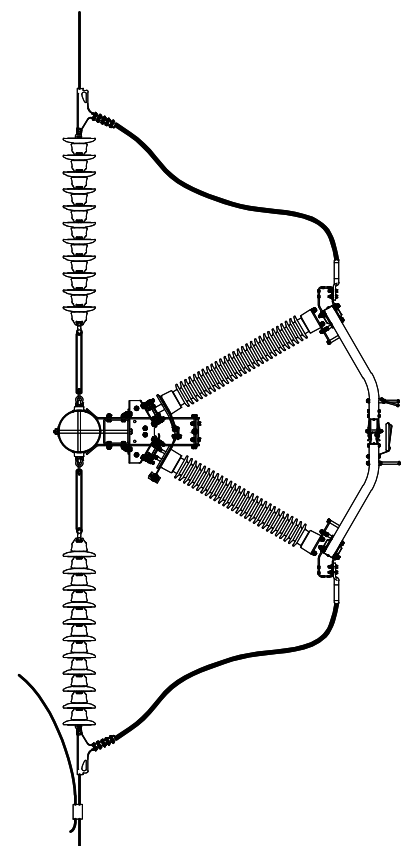
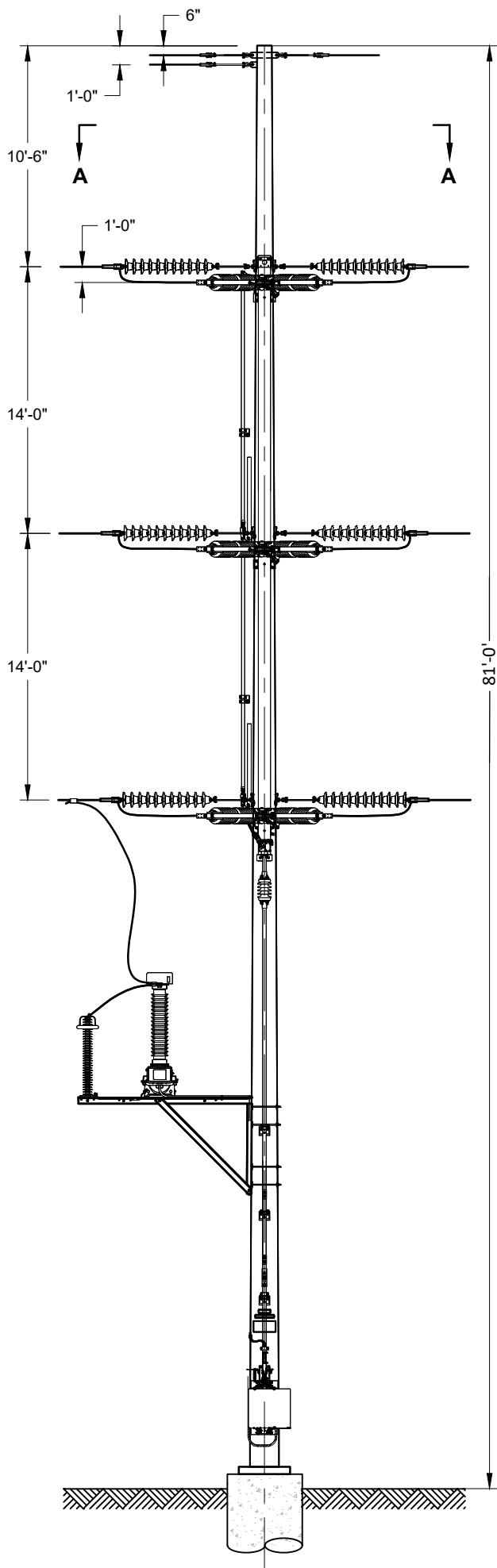

SECTION A-A

STRUCTURES 49A, 50A, & 50-1

KATCo
 Keystone Application Transmission Company
 A Fortney Group Company

KISKI VALLEY - NORTH WASHINGTON 138 kV
 TRANSMISSION LINE INTERCONNECTION PROJECT

138kV SINGLE CIRCUIT TUBULAR STEEL
 UNITIZED 2000A SWITCH STRUCTURE

EXHIBIT 5

PAPER SIZE: 8.5X11

SCALE: NTS

CE25-246-WP

EXHIBIT 6

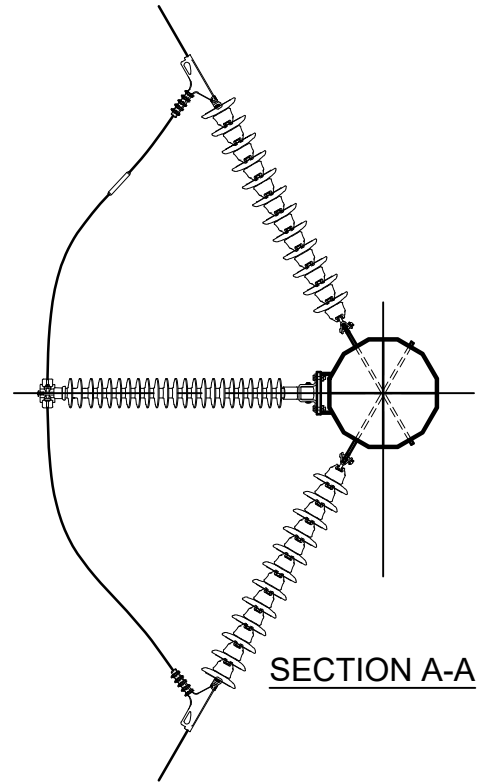
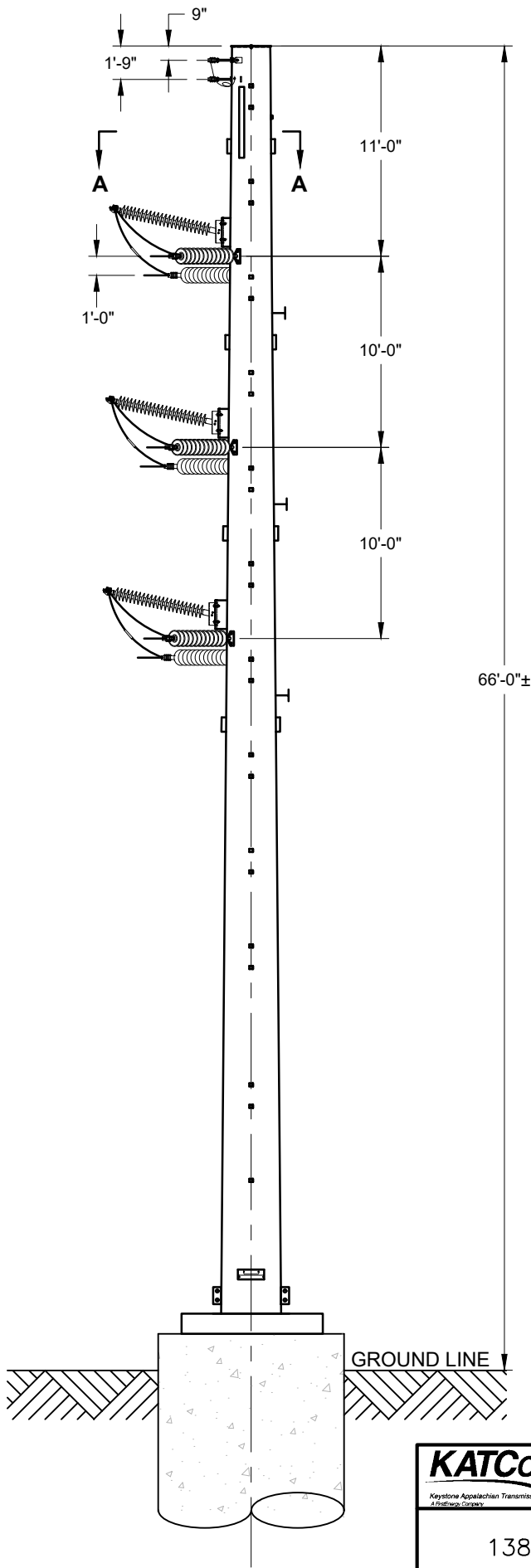

SECTION A-A

STRUCTURE # 50-2

KATCo
Keystone Appalachian Transmission Company
 A Fortney Group Company

KISKI VALLEY - NORTH WASHINGTON 138 kV
 TRANSMISSION LINE INTERCONNECTION PROJECT

138kV SINGLE CIRCUIT STEEL POLE DEADEND

EXHIBIT 6

PAPER SIZE: 8.5X11

SCALE: NTS

CE25-246-WP

EXHIBIT 7

Field Report Memo

Date:	December 3, 2025
Project No.	R251609.00, Task 001
Project Name:	Kiski Valley – North Washington Interconnect, Westmoreland County, Pennsylvania

Summary of Events

On September 30, 2025 GAI Consultants, Inc. (GAI), on behalf of FirstEnergy Corporation, conducted an environmental resource survey for wetlands and streams within the approximately 8-acre study area for the Kiski Valley – North Washington Project (R251609.00) in Westmoreland County, Pennsylvania (PA). The project will connect a new substation to an existing 138kV transmission line in Washington Township, Westmoreland County Pa.

Review of existing data indicates the Project area is within the Pine Run Hydrologic Unit Code 12 (050100080204) Watershed. Land use surrounding the Project study area consists of forest as well as residential and transmission line right of way. Attachment 1 depicts the Project area.

Wetland and Stream Field Survey Results

The study area was reviewed for wetlands according to the 1987 United States Army Corps of Engineers (USACE) *Wetlands Delineation Manual* and the *Regional Supplement to the Corps of Engineers Wetland Delineation Manual: Eastern Mountains and Piedmont Region* (Version 2.0). Prior to the environmental field review, GAI obtained and reviewed United States Geological Survey topographic mapping, National Wetlands Inventory database, National Hydrography Dataset (NHD), and the United States Department of Agriculture-Natural Resources Conservation Service's soil mapping to supplement the field data. No NHD streams or National Wetlands Inventory wetlands were identified within the Project area.

A total of three wetlands were identified during the environmental resource study. Wetland WPA-LMB-001, WPA-LMB-002, and WPA-LMB-003 were identified as an adjacent PEM (Palustrine Emergent) wetland. WPA-LMB-001 and WPA-LMB-003 consist of GcB: Gilpin channery silt loam, 3 to 8 percent slope, WPA-LMB-002 consists of GcC: Gilpin channery silt loam, 8 to 15 percent slopes.

The results of the wetland and stream survey are displayed on the Feature Overview Map in Attachment 1, USACE wetland and upland determination forms are included in Attachment 2, and representative photographs of the identified features are provided in Attachment 3.

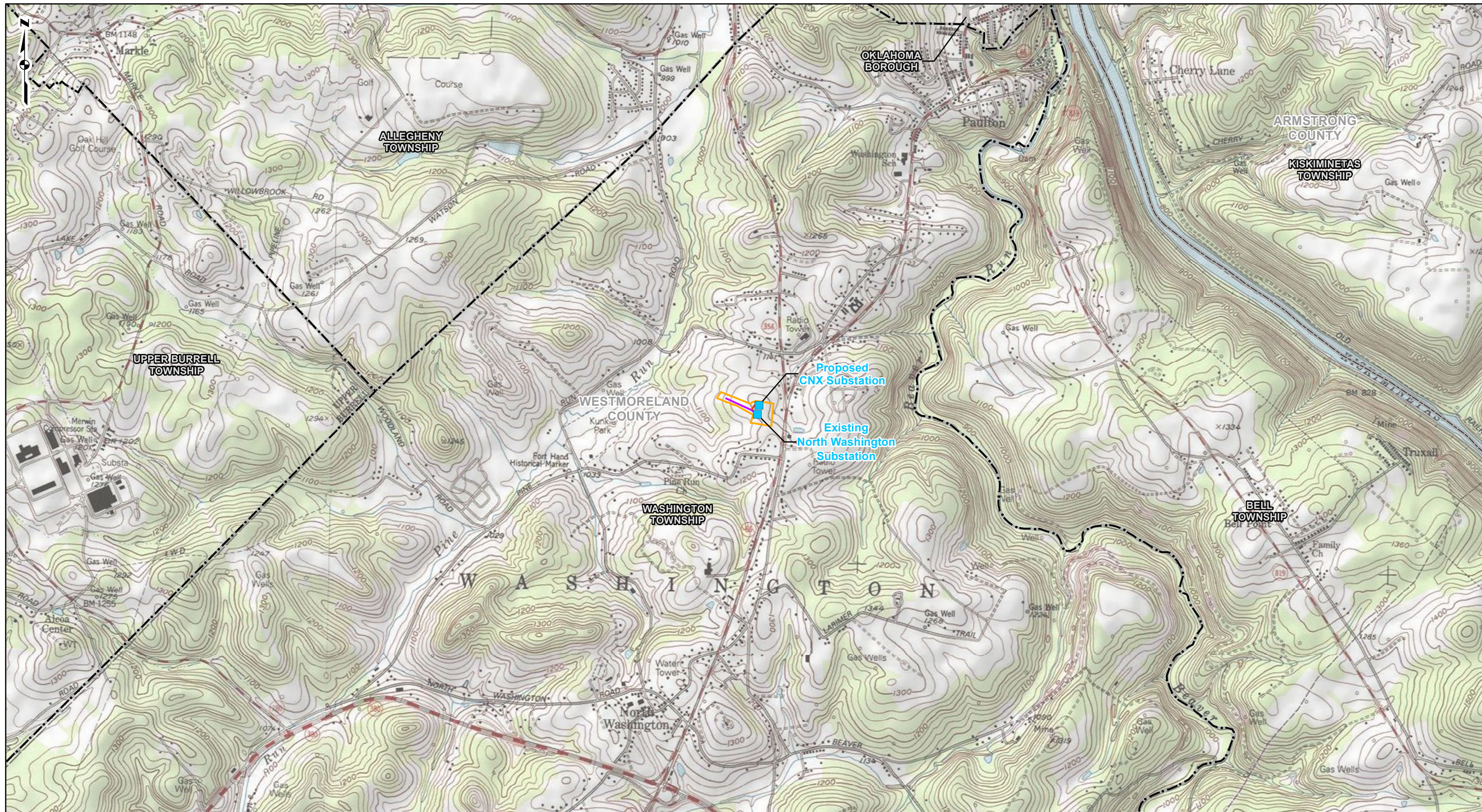

ATTACHMENT 1
FEATURE OVERVIEW MAP

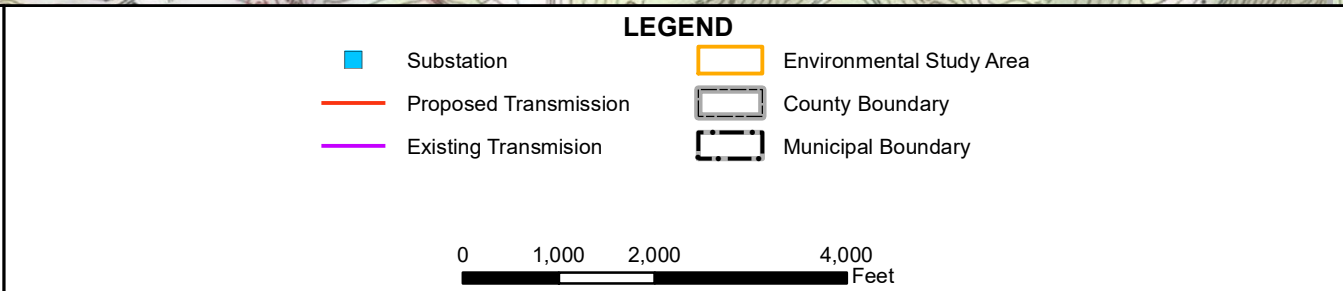

REFERENCE: USGS 7.5' TOPOGRAPHIC QUADRANGLES: NEW KENSINGTON EAST (1980) AND VANDERGRIFT (1980), PENNSYLVANIA, OBTAINED THROUGH ESRI USA TOPO MAPS, NATIONAL GEOGRAPHIC TOPO AND USGS, ACCESSED 12/2025.



**FIGURE 1
PROJECT LOCATION MAP**

**KISKI VALLEY-NORTH WASHINGTON
138kV INTERCONNECT PROJECT**
 FIRSTENERGY CORPORATION
 

DRAWN BY: MTS DATE: 12/9/2025
 CHECKED: JAP APPROVED: BMR



PROJECT LOCATION

WESTMORELAND COUNTY, PENNSYLVANIA

REFERENCE: WORLD IMAGERY, MAXAR (2024), ESRI, ARCGIS ONLINE, ACCESSED 12/2025. WORLD TRANSPORTATION, ESRI, ARCGIS ONLINE, ACCESSED 12/2025. NATIONAL HYDROGRAPHY DATASET (NHD) STREAMS, USGS, 2023. NATIONAL WETLAND INVENTORY (NWI) WETLANDS, USFWS, 2024. SOIL SURVEY GEOGRAPHIC (SSURGO) DATABASE, USDA/NRCS, 2025. FLOODPLAINS/FLOODWAYS, FEDERAL EMERGENCY MANAGEMENT AGENCY (FEMA), 2024. CONTOUR DATA, PAMAP PROGRAM, PA DCNR, PASDA, 2006.

LEGEND

- ▼ Upland Data Point
- ▲ Wetland Data Point
- Open-Ended Boundary
- Wetland
- Environmental Study Area
- - - NHD Stream
- ▨ NWI Wetland
- Soil Type Boundary
- 100-Year FEMA Floodplain
- 2-Ft Contour

0 100 200 400 Feet

**FIGURE 2
RESOURCE LOCATION MAP**

**KISKI VALLEY-NORTH WASHINGTON
138kV INTERCONNECT PROJECT**
 FIRSTENERGY CORPORATION

DRAWN BY: MTS DATE: 12/9/2025
 CHECKED: JAP APPROVED: BMR

ATTACHMENT 2
WETLAND DETERMINATION FORMS

WETLAND DETERMINATION DATA FORM – Eastern Mountains and Piedmont

Project/Site: R251609.00 Kiski Interconnect City/County: Westmoreland Sampling Date: 09/30/2025
 Applicant/Owner: FirstEnergy State: PA Sampling Point: WPA-LMB-001
 Investigator(s): LMB/NDR Section, Township, Range: N/A

Landform (hillslope, terrace, etc.): Hillslope Local relief (concave, convex, none): Concave Slope (%): 5
 Subregion (LRR or MLRA): LRR N Lat: 40.551205 Long: -79.593023 Datum: NAD 83

Soil Map Unit Name: GcB: Gilpin channery silt loam, 3 to 8 percent slope NWI classification: None

Are climatic / hydrologic conditions on the site typical for this time of year? Yes No (If no, explain in Remarks.)

Are Vegetation , Soil , or Hydrology significantly disturbed? Are "Normal Circumstances" present? Yes No

Are Vegetation , Soil , or Hydrology naturally problematic? (If needed, explain any answers in Remarks.)

SUMMARY OF FINDINGS – Attach site map showing sampling point locations, transects, important features, etc.

Hydrophytic Vegetation Present? Yes <input checked="" type="checkbox"/> No <input type="checkbox"/> Hydric Soil Present? Yes <input checked="" type="checkbox"/> No <input type="checkbox"/> Wetland Hydrology Present? Yes <input checked="" type="checkbox"/> No <input type="checkbox"/>	Is the Sampled Area within a Wetland? Yes <input checked="" type="checkbox"/> No <input type="checkbox"/>
Remarks: Data point for PEM adjacent wetland WPA-LMB-001	

HYDROLOGY

Wetland Hydrology Indicators: <u>Primary Indicators (minimum of one is required; check all that apply)</u> <input type="checkbox"/> Surface Water (A1) <input type="checkbox"/> True Aquatic Plants (B14) <input type="checkbox"/> High Water Table (A2) <input type="checkbox"/> Hydrogen Sulfide Odor (C1) <input type="checkbox"/> Saturation (A3) <input checked="" type="checkbox"/> Oxidized Rhizospheres on Living Roots (C3) <input type="checkbox"/> Water Marks (B1) <input type="checkbox"/> Presence of Reduced Iron (C4) <input type="checkbox"/> Sediment Deposits (B2) <input type="checkbox"/> Recent Iron Reduction in Tilled Soils (C6) <input type="checkbox"/> Drift Deposits (B3) <input type="checkbox"/> Thin Muck Surface (C7) <input type="checkbox"/> Algal Mat or Crust (B4) <input type="checkbox"/> Other (Explain in Remarks) <input type="checkbox"/> Iron Deposits (B5) <input type="checkbox"/> Inundation Visible on Aerial Imagery (B7) <input type="checkbox"/> Water-Stained Leaves (B9) <input type="checkbox"/> Aquatic Fauna (B13)	<u>Secondary Indicators (minimum of two required)</u> <input type="checkbox"/> Surface Soil Cracks (B6) <input type="checkbox"/> Sparsely Vegetated Concave Surface (B8) <input type="checkbox"/> Drainage Patterns (B10) <input type="checkbox"/> Moss Trim Lines (B16) <input type="checkbox"/> Dry-Season Water Table (C2) <input type="checkbox"/> Crayfish Burrows (C8) <input type="checkbox"/> Saturation Visible on Aerial Imagery (C9) <input type="checkbox"/> Stunted or Stressed Plants (D1) <input checked="" type="checkbox"/> Geomorphic Position (D2) <input type="checkbox"/> Shallow Aquitard (D3) <input type="checkbox"/> Microtopographic Relief (D4) <input checked="" type="checkbox"/> FAC-Neutral Test (D5)
Field Observations: Surface Water Present? Yes <input type="checkbox"/> No <input checked="" type="checkbox"/> Depth (inches): _____ Water Table Present? Yes <input type="checkbox"/> No <input checked="" type="checkbox"/> Depth (inches): _____ Saturation Present? Yes <input type="checkbox"/> No <input checked="" type="checkbox"/> Depth (inches): _____ (includes capillary fringe)	Wetland Hydrology Present? Yes <input checked="" type="checkbox"/> No <input type="checkbox"/>
Describe Recorded Data (stream gauge, monitoring well, aerial photos, previous inspections), if available:	

Remarks:

None

VEGETATION (Four Strata) – Use scientific names of plants.

Sampling Point: WPA-LMB-001

	Absolute % Cover	Dominant Species?	Indicator Status	
Tree Stratum (Plot size: <u>30</u>)				
1. <u>Absent</u>		-	-	Dominance Test worksheet: Number of Dominant Species That Are OBL, FACW, or FAC: <u>2</u> (A) Total Number of Dominant Species Across All Strata: <u>2</u> (B) Percent of Dominant Species That Are OBL, FACW, or FAC: <u>100%</u> (A/B)
2. _____		-	-	
3. _____		-	-	
4. _____		-	-	
5. _____		-	-	
6. _____		-	-	
7. _____		-	-	
8. _____		-	-	
	<u>0</u>	= Total Cover		
Sapling/Shrub Stratum (Plot size: <u>15</u>)				
1. <u>Absent</u>		-	-	Prevalence Index worksheet: Total % Cover of: _____ Multiply by: _____ OBL species _____ x 1 = _____ FACW species _____ x 2 = _____ FAC species _____ x 3 = _____ FACU species _____ x 4 = _____ UPL species _____ x 5 = _____ Column Totals: <u>0</u> (A) <u>0</u> (B) Prevalence Index = B/A = <u>0</u>
2. _____		-	-	
3. _____		-	-	
4. _____		-	-	
5. _____		-	-	
6. _____		-	-	
7. _____		-	-	
8. _____		-	-	
9. _____		-	-	
10. _____		-	-	
	<u>0</u>	= Total Cover		
Herb Stratum (Plot size: <u>5</u>)				
1. <u>Cyperus strigosus</u>	<u>45</u>	YES	FACW	Hydrophytic Vegetation Indicators: <input checked="" type="checkbox"/> 1 - Rapid Test for Hydrophytic Vegetation <input checked="" type="checkbox"/> 2 - Dominance Test is >50% <input type="checkbox"/> 3 - Prevalence Index is ≤3.0 ¹ <input type="checkbox"/> 4 - Morphological Adaptations ¹ (Provide supporting data in Remarks or on a separate sheet) <input type="checkbox"/> Problematic Hydrophytic Vegetation ¹ (Explain)
2. <u>Juncus effusus</u>	<u>20</u>	YES	FACW	
3. <u>Solidago rugosa</u>	<u>10</u>	NO	FAC	
4. <u>Carex vulpinoidea</u>	<u>10</u>	NO	OBL	
5. <u>Phalaris arundinacea</u>	<u>10</u>	NO	FACW	
6. <u>Symphotrichum lateriflorum</u>	<u>5</u>	NO	FACW	
7. _____		-	-	
8. _____		-	-	
9. _____		-	-	
10. _____		-	-	
11. _____		-	-	
12. _____		-	-	
	<u>100</u>	= Total Cover		
Woody Vine Stratum (Plot size: <u>30</u>)				
1. <u>Absent</u>		-	-	Definitions of Four Vegetation Strata: Tree – Woody plants, excluding vines, 3 in. (7.6 cm) or more in diameter at breast height (DBH), regardless of height. Sapling/Shrub – Woody plants, excluding vines, less than 3 in. DBH and greater than 3.28 ft (1 m) tall. Herb – All herbaceous (non-woody) plants, regardless of size, and woody plants less than 3.28 ft tall. Woody vine – All woody vines greater than 3.28 ft in height.
2. _____		-	-	
3. _____		-	-	
4. _____		-	-	
5. _____		-	-	
6. _____		-	-	
	<u>0</u>	= Total Cover		
Hydrophytic Vegetation Present? Yes <input checked="" type="checkbox"/> No _____				
Remarks: (Include photo numbers here or on a separate sheet.)				

WETLAND DETERMINATION DATA FORM – Eastern Mountains and Piedmont

Project/Site: R251609.00 Kiski Interconnect City/County: Westmoreland Sampling Date: 09/30/2025
 Applicant/Owner: FirstEnergy State: PA Sampling Point: WPA-LMB-002
 Investigator(s): LMB/NDR Section, Township, Range: N/A

Landform (hillslope, terrace, etc.): Hillslope Local relief (concave, convex, none): Concave Slope (%): 5
 Subregion (LRR or MLRA): LRR N Lat: 40.551321 Long: -79.593494 Datum: NAD 83

Soil Map Unit Name: GcC: Gilpin channery silt loam, 8 to 15 percent slopes NWI classification: None

Are climatic / hydrologic conditions on the site typical for this time of year? Yes No (If no, explain in Remarks.)

Are Vegetation , Soil , or Hydrology significantly disturbed? Are "Normal Circumstances" present? Yes No

Are Vegetation , Soil , or Hydrology naturally problematic? (If needed, explain any answers in Remarks.)

SUMMARY OF FINDINGS – Attach site map showing sampling point locations, transects, important features, etc.

Hydrophytic Vegetation Present? Yes <input checked="" type="checkbox"/> No <input type="checkbox"/> Hydric Soil Present? Yes <input checked="" type="checkbox"/> No <input type="checkbox"/> Wetland Hydrology Present? Yes <input checked="" type="checkbox"/> No <input type="checkbox"/>	Is the Sampled Area within a Wetland? Yes <input checked="" type="checkbox"/> No <input type="checkbox"/>
Remarks: Data point for PEM adjacent wetland WPA-LMB-002	

HYDROLOGY

Wetland Hydrology Indicators: <u>Primary Indicators (minimum of one is required; check all that apply)</u> <input type="checkbox"/> Surface Water (A1) <input type="checkbox"/> True Aquatic Plants (B14) <input type="checkbox"/> High Water Table (A2) <input type="checkbox"/> Hydrogen Sulfide Odor (C1) <input type="checkbox"/> Saturation (A3) <input checked="" type="checkbox"/> Oxidized Rhizospheres on Living Roots (C3) <input type="checkbox"/> Water Marks (B1) <input type="checkbox"/> Presence of Reduced Iron (C4) <input type="checkbox"/> Sediment Deposits (B2) <input type="checkbox"/> Recent Iron Reduction in Tilled Soils (C6) <input type="checkbox"/> Drift Deposits (B3) <input type="checkbox"/> Thin Muck Surface (C7) <input type="checkbox"/> Algal Mat or Crust (B4) <input type="checkbox"/> Other (Explain in Remarks) <input type="checkbox"/> Iron Deposits (B5) <input type="checkbox"/> Inundation Visible on Aerial Imagery (B7) <input type="checkbox"/> Water-Stained Leaves (B9) <input type="checkbox"/> Aquatic Fauna (B13)	<u>Secondary Indicators (minimum of two required)</u> <input type="checkbox"/> Surface Soil Cracks (B6) <input type="checkbox"/> Sparsely Vegetated Concave Surface (B8) <input type="checkbox"/> Drainage Patterns (B10) <input type="checkbox"/> Moss Trim Lines (B16) <input type="checkbox"/> Dry-Season Water Table (C2) <input type="checkbox"/> Crayfish Burrows (C8) <input type="checkbox"/> Saturation Visible on Aerial Imagery (C9) <input type="checkbox"/> Stunted or Stressed Plants (D1) <input checked="" type="checkbox"/> Geomorphic Position (D2) <input type="checkbox"/> Shallow Aquitard (D3) <input type="checkbox"/> Microtopographic Relief (D4) <input checked="" type="checkbox"/> FAC-Neutral Test (D5)
Field Observations: Surface Water Present? Yes <input type="checkbox"/> No <input checked="" type="checkbox"/> Depth (inches): _____ Water Table Present? Yes <input type="checkbox"/> No <input checked="" type="checkbox"/> Depth (inches): _____ Saturation Present? Yes <input type="checkbox"/> No <input checked="" type="checkbox"/> Depth (inches): _____ (includes capillary fringe)	Wetland Hydrology Present? Yes <input checked="" type="checkbox"/> No <input type="checkbox"/>
Describe Recorded Data (stream gauge, monitoring well, aerial photos, previous inspections), if available:	

Remarks:

None

VEGETATION (Four Strata) – Use scientific names of plants.

Sampling Point: WPA-LMB-002

	Absolute % Cover	Dominant Species?	Indicator Status	
Tree Stratum (Plot size: <u>30</u>)				
1. <u>Absent</u>		-	-	Dominance Test worksheet: Number of Dominant Species That Are OBL, FACW, or FAC: <u>2</u> (A) Total Number of Dominant Species Across All Strata: <u>2</u> (B) Percent of Dominant Species That Are OBL, FACW, or FAC: <u>100%</u> (A/B)
2. _____		-	-	
3. _____		-	-	
4. _____		-	-	
5. _____		-	-	
6. _____		-	-	
7. _____		-	-	
8. _____		-	-	
	<u>0</u>	= Total Cover		
Sapling/Shrub Stratum (Plot size: <u>15</u>)				
1. <u>Absent</u>		-	-	Prevalence Index worksheet: Total % Cover of: _____ Multiply by: _____ OBL species _____ x 1 = _____ FACW species _____ x 2 = _____ FAC species _____ x 3 = _____ FACU species _____ x 4 = _____ UPL species _____ x 5 = _____ Column Totals: <u>0</u> (A) <u>0</u> (B) Prevalence Index = B/A = <u>0</u>
2. _____		-	-	
3. _____		-	-	
4. _____		-	-	
5. _____		-	-	
6. _____		-	-	
7. _____		-	-	
8. _____		-	-	
9. _____		-	-	
10. _____		-	-	
	<u>0</u>	= Total Cover		
Herb Stratum (Plot size: <u>5</u>)				
1. <u>Cyperus strigosus</u>	<u>40</u>	YES	FACW	Hydrophytic Vegetation Indicators: <input checked="" type="checkbox"/> 1 - Rapid Test for Hydrophytic Vegetation <input checked="" type="checkbox"/> 2 - Dominance Test is >50% <input type="checkbox"/> 3 - Prevalence Index is ≤3.0 ¹ <input type="checkbox"/> 4 - Morphological Adaptations ¹ (Provide supporting data in Remarks or on a separate sheet) <input type="checkbox"/> Problematic Hydrophytic Vegetation ¹ (Explain)
2. <u>Echinochloa crus-galli</u>	<u>20</u>	YES	FAC	
3. <u>Carex vulpinoidea</u>	<u>10</u>	NO	OBL	
4. <u>Euthamia graminifolia</u>	<u>10</u>	NO	FAC	
5. <u>Symphotrichum lateriflorum</u>	<u>10</u>	NO	FACW	
6. <u>Phalaris arundinacea</u>	<u>5</u>	NO	FACW	
7. <u>Setaria faberi</u>	<u>5</u>	NO	UPL	
8. _____		-	-	
9. _____		-	-	
10. _____		-	-	
11. _____		-	-	
12. _____		-	-	
	<u>100</u>	= Total Cover		
Woody Vine Stratum (Plot size: <u>30</u>)				
1. <u>Absent</u>		-	-	Definitions of Four Vegetation Strata: Tree – Woody plants, excluding vines, 3 in. (7.6 cm) or more in diameter at breast height (DBH), regardless of height. Sapling/Shrub – Woody plants, excluding vines, less than 3 in. DBH and greater than 3.28 ft (1 m) tall. Herb – All herbaceous (non-woody) plants, regardless of size, and woody plants less than 3.28 ft tall. Woody vine – All woody vines greater than 3.28 ft in height. Hydrophytic Vegetation Present? Yes <input checked="" type="checkbox"/> No _____
2. _____		-	-	
3. _____		-	-	
4. _____		-	-	
5. _____		-	-	
6. _____		-	-	
7. _____		-	-	
8. _____		-	-	
	<u>0</u>	= Total Cover		
Remarks: (Include photo numbers here or on a separate sheet.)				

WETLAND DETERMINATION DATA FORM – Eastern Mountains and Piedmont

Project/Site: R251609.00 Kiski Interconnect City/County: Westmoreland Sampling Date: 09/30/2025
 Applicant/Owner: FirstEnergy State: PA Sampling Point: WPA-LMB-003
 Investigator(s): LMB/NDR Section, Township, Range: N/A

Landform (hillslope, terrace, etc.): Terrace Local relief (concave, convex, none): None Slope (%): 0
 Subregion (LRR or MLRA): LRR N Lat: 40.551252 Long: -79.591620 Datum: NAD 83

Soil Map Unit Name: GcB: Gilpin channery silt loam, 3 to 8 percent slopes NWI classification: None

Are climatic / hydrologic conditions on the site typical for this time of year? Yes No (If no, explain in Remarks.)

Are Vegetation , Soil , or Hydrology significantly disturbed? Are "Normal Circumstances" present? Yes No

Are Vegetation , Soil , or Hydrology naturally problematic? (If needed, explain any answers in Remarks.)

SUMMARY OF FINDINGS – Attach site map showing sampling point locations, transects, important features, etc.

Hydrophytic Vegetation Present? Yes <input checked="" type="checkbox"/> No <input type="checkbox"/> Hydric Soil Present? Yes <input checked="" type="checkbox"/> No <input type="checkbox"/> Wetland Hydrology Present? Yes <input checked="" type="checkbox"/> No <input type="checkbox"/>	Is the Sampled Area within a Wetland? Yes <input checked="" type="checkbox"/> No <input type="checkbox"/>
Remarks: Data point for PEM adjacent wetland WPA-LMB-003	

HYDROLOGY

Wetland Hydrology Indicators: <u>Primary Indicators (minimum of one is required; check all that apply)</u> <input type="checkbox"/> Surface Water (A1) <input type="checkbox"/> True Aquatic Plants (B14) <input type="checkbox"/> High Water Table (A2) <input type="checkbox"/> Hydrogen Sulfide Odor (C1) <input type="checkbox"/> Saturation (A3) <input checked="" type="checkbox"/> Oxidized Rhizospheres on Living Roots (C3) <input type="checkbox"/> Water Marks (B1) <input type="checkbox"/> Presence of Reduced Iron (C4) <input type="checkbox"/> Sediment Deposits (B2) <input type="checkbox"/> Recent Iron Reduction in Tilled Soils (C6) <input type="checkbox"/> Drift Deposits (B3) <input type="checkbox"/> Thin Muck Surface (C7) <input type="checkbox"/> Algal Mat or Crust (B4) <input type="checkbox"/> Other (Explain in Remarks) <input type="checkbox"/> Iron Deposits (B5) <input type="checkbox"/> Inundation Visible on Aerial Imagery (B7) <input type="checkbox"/> Water-Stained Leaves (B9) <input type="checkbox"/> Aquatic Fauna (B13)	<u>Secondary Indicators (minimum of two required)</u> <input checked="" type="checkbox"/> Surface Soil Cracks (B6) <input checked="" type="checkbox"/> Sparsely Vegetated Concave Surface (B8) <input type="checkbox"/> Drainage Patterns (B10) <input type="checkbox"/> Moss Trim Lines (B16) <input type="checkbox"/> Dry-Season Water Table (C2) <input type="checkbox"/> Crayfish Burrows (C8) <input type="checkbox"/> Saturation Visible on Aerial Imagery (C9) <input type="checkbox"/> Stunted or Stressed Plants (D1) <input checked="" type="checkbox"/> Geomorphic Position (D2) <input type="checkbox"/> Shallow Aquitard (D3) <input type="checkbox"/> Microtopographic Relief (D4) <input checked="" type="checkbox"/> FAC-Neutral Test (D5)
Field Observations: Surface Water Present? Yes <input type="checkbox"/> No <input checked="" type="checkbox"/> Depth (inches): _____ Water Table Present? Yes <input type="checkbox"/> No <input checked="" type="checkbox"/> Depth (inches): _____ Saturation Present? (includes capillary fringe) Yes <input type="checkbox"/> No <input checked="" type="checkbox"/> Depth (inches): _____	Wetland Hydrology Present? Yes <input checked="" type="checkbox"/> No <input type="checkbox"/>
Describe Recorded Data (stream gauge, monitoring well, aerial photos, previous inspections), if available:	

Remarks:

None

VEGETATION (Four Strata) – Use scientific names of plants.

Sampling Point: WPA-LMB-003

	Absolute % Cover	Dominant Species?	Indicator Status	
Tree Stratum (Plot size: <u>30</u>)				
1. <u>Absent</u>		-	-	Dominance Test worksheet: Number of Dominant Species That Are OBL, FACW, or FAC: <u>3</u> (A) Total Number of Dominant Species Across All Strata: <u>3</u> (B) Percent of Dominant Species That Are OBL, FACW, or FAC: <u>100%</u> (A/B)
2. _____		-	-	
3. _____		-	-	
4. _____		-	-	
5. _____		-	-	
6. _____		-	-	
7. _____		-	-	
8. _____		-	-	
	<u>0</u>	= Total Cover		
Sapling/Shrub Stratum (Plot size: <u>15</u>)				
1. <u>Absent</u>		-	-	Prevalence Index worksheet: Total % Cover of: _____ Multiply by: _____ OBL species _____ x 1 = _____ FACW species _____ x 2 = _____ FAC species _____ x 3 = _____ FACU species _____ x 4 = _____ UPL species _____ x 5 = _____ Column Totals: <u>0</u> (A) <u>0</u> (B) Prevalence Index = B/A = <u>0</u>
2. _____		-	-	
3. _____		-	-	
4. _____		-	-	
5. _____		-	-	
6. _____		-	-	
7. _____		-	-	
8. _____		-	-	
9. _____		-	-	
10. _____		-	-	
	<u>0</u>	= Total Cover		
Herb Stratum (Plot size: <u>5</u>)				
1. <u>Typha latifolia</u>	<u>20</u>	YES	OBL	Hydrophytic Vegetation Indicators: <input checked="" type="checkbox"/> 1 - Rapid Test for Hydrophytic Vegetation <input checked="" type="checkbox"/> 2 - Dominance Test is >50% <input type="checkbox"/> 3 - Prevalence Index is ≤3.0 ¹ <input type="checkbox"/> 4 - Morphological Adaptations ¹ (Provide supporting data in Remarks or on a separate sheet) <input type="checkbox"/> Problematic Hydrophytic Vegetation ¹ (Explain)
2. <u>Schoenoplectus tabernaemontani</u>	<u>20</u>	YES	OBL	
3. <u>Juncus acuminatus</u>	<u>20</u>	YES	OBL	
4. <u>Eleocharis obtusa</u>	<u>10</u>	NO	OBL	
5. <u>Phalaris arundinacea</u>	<u>10</u>	NO	FACW	
6. _____		-	-	
7. _____		-	-	
8. _____		-	-	
9. _____		-	-	
10. _____		-	-	
11. _____		-	-	
12. _____		-	-	
	<u>80</u>	= Total Cover		
Woody Vine Stratum (Plot size: <u>30</u>)				
1. <u>Absent</u>		-	-	Definitions of Four Vegetation Strata: Tree – Woody plants, excluding vines, 3 in. (7.6 cm) or more in diameter at breast height (DBH), regardless of height. Sapling/Shrub – Woody plants, excluding vines, less than 3 in. DBH and greater than 3.28 ft (1 m) tall. Herb – All herbaceous (non-woody) plants, regardless of size, and woody plants less than 3.28 ft tall. Woody vine – All woody vines greater than 3.28 ft in height.
2. _____		-	-	
3. _____		-	-	
4. _____		-	-	
5. _____		-	-	
6. _____		-	-	
	<u>0</u>	= Total Cover		
Hydrophytic Vegetation Present? Yes <input checked="" type="checkbox"/> No _____				
Remarks: (Include photo numbers here or on a separate sheet.)				

ATTACHMENT 3
PHOTOGRAPH



**Photograph 1. WPA-LMB-001 PEM adjacent,
Facing Northwest (09/30/2025)**



**Photograph 2. WPA-LMB-001 PEM adjacent,
Facing South (09/30/2025)**



**Photograph 3. WPA-LMB-001 PEM adjacent,
Facing Southeast (09/30/2025)**



**Photograph 4. WPA-LMB-001 PEM Adjacent,
Facing North (09/30/2025)**



**Photograph 5. WPA-LMB-002 PEM adjacent,
Facing Northwest (09/30/2025)**



**Photograph 6. WPA-LMB-002 PEM adjacent,
Facing North (09/30/2025)**



Photograph 7. WPA-LMB-002 PEM adjacent, Facing Southeast (09/30/2025)



Photograph 8. WPA-LMB-002 PEM adjacent, Facing South (09/30/2025)



Photograph 9. WPA-LMB-003 Pem adjacent Facing Northwest (09/30/2025)



Photograph 10. WPA-LMB-003 PEM adjacent Facing Southeast (09/30/2025)



Photograph 11. WPA-LMB-003 PEM adjacent Facing South (09/30/2025)



Photograph 12. WPA-LMB-003 PEM adjacent Facing North (09/30/2025)

EXHIBIT 8

1. PROJECT INFORMATION

EXHIBIT 8

Project Name: **Kiski Valley-North Washington 138kV Interconnect Project**

Date of Review: **12/12/2025 12:21:37 PM**

Project Category: **Energy Storage, Production, and Transfer, Energy Transfer, Power/electric line - service, replace existing above/under-ground line**

Project Area: **5.62 acres**

County(s): **Westmoreland**

Township/Municipality(s): **Washington Township**

ZIP Code:

Quadrangle Name(s): **VANDERGRIFT**

Watersheds HUC 8: **Kiskiminetas**

Watersheds HUC 12: **Beaver Run Reservoir-Beaver Run; Pine Run**

Decimal Degrees: **40.550745, -79.591728**

Degrees Minutes Seconds: **40° 33' 2.6802" N, 79° 35' 30.2203" W**



2. SEARCH RESULTS

Agency	Results	Response
PA Game Commission	Conservation Measure	No Further Review Required, See Agency Comments
PA Department of Conservation and Natural Resources	No Known Impact	No Further Review Required
PA Fish and Boat Commission	No Known Impact	No Further Review Required
U.S. Fish and Wildlife Service	No Known Impact	No Further Review Required

Pennsylvania Natural Diversity Inventory (PNDI) records indicate that while threatened and endangered and/or special concern species and resources are in the project vicinity and that recommended Conservation Measures should be implemented in their entirety to avoid and minimize impacts to these species, no further coordination is required with the jurisdictional agencies. If a DEP permit is required for this project, DEP has the discretion to incorporate one or more Conservation Measures into its permit. This response does not reflect potential agency concerns regarding potential impacts to other ecological resources, such as wetlands.

Kiski Valley-North Washington 138kV Interconnect Project





-  Buffered Project Boundary
-  Project Boundary

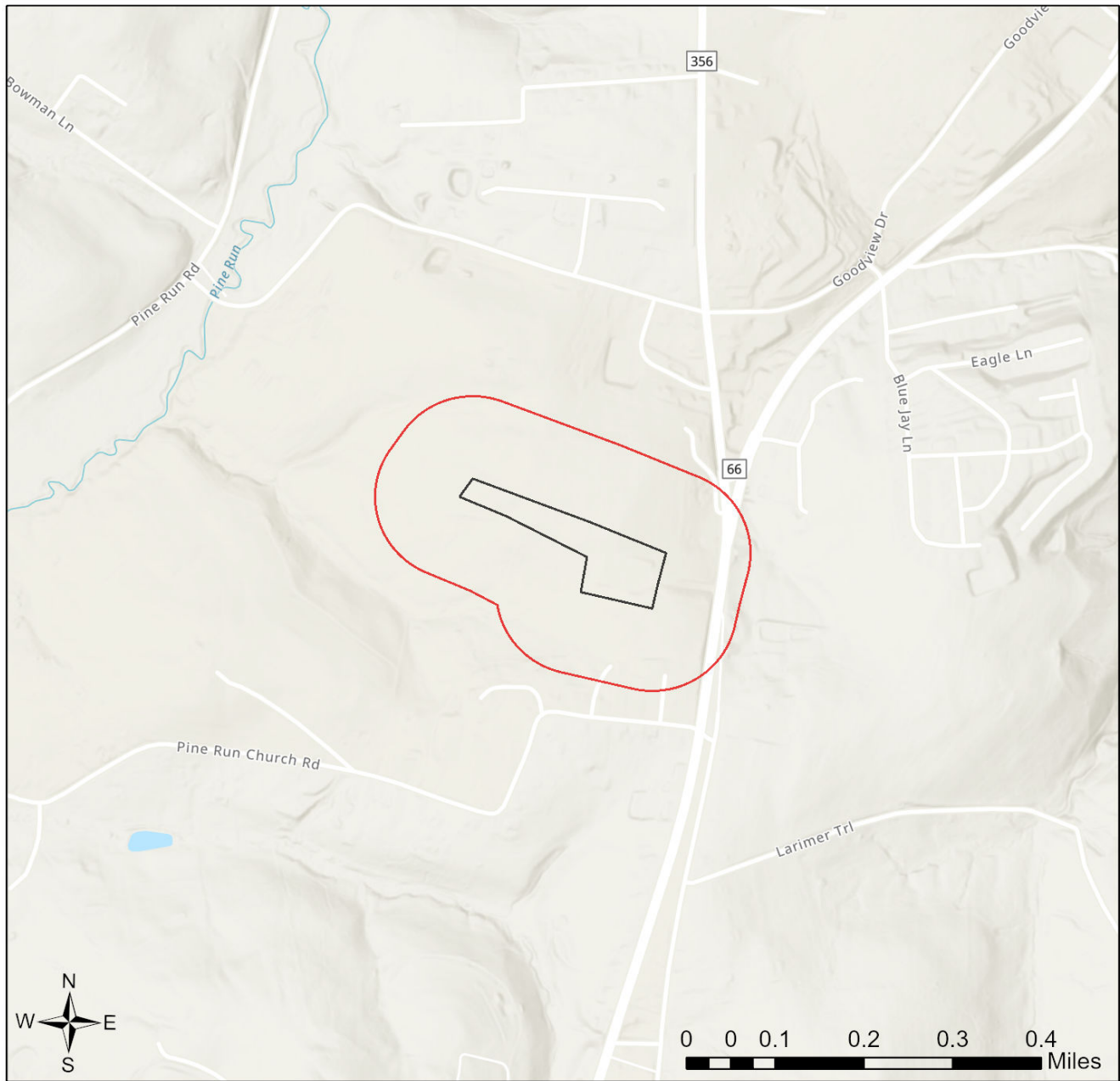

Sources: Esri, Vantor, Airbus DS, USGS, NGA, NASA, CGIAR, N Robinson, NCEAS, NLS, OS, NMA, Geodatastyrelsen, Rijkswaterstaat, GSA, Geoland, FEMA, Intermap, and the GIS user community

Kiski Valley-North Washington 138kV Interconnect Project



-  Buffered Project Boundary
-  Project Boundary



Sources: Esri, Vantor, Airbus DS, USGS, NGA, NASA, CGIAR, N Robinson, NCEAS, NLS, OS, NMA, Geodatastyrelsen, Rijkswaterstaat, GSA, Geoland, FEMA, Intermap, and the GIS user community

RESPONSE TO QUESTION(S) ASKED

Q1: Will the action include disturbance to trees such as tree cutting (or other means of knocking down, or bringing down trees, tree topping, or tree trimming), pesticide/herbicide application or prescribed fire?

Your answer is: No

Q2: Does the action area contain any caves (or associated sinkholes, fissures, or other karst features), mines, rocky outcroppings, culverts, or tunnels that could provide habitat for hibernating bats?

Your answer is: No

Q3: Will the action include disturbance to trees such as tree cutting (or other means of knocking down, or bringing down trees, tree topping, or tree trimming), pesticide/herbicide application or prescribed fire?

Your answer is: No

Q4: Does the action area contain any caves (or associated sinkholes, fissures, or other karst features), mines, rocky outcroppings, culverts, or tunnels that could provide habitat for hibernating bats?

Your answer is: No

3. AGENCY COMMENTS

Regardless of whether a DEP permit is necessary for this proposed project, any potential impacts to threatened and endangered species and/or special concern species and resources must be resolved with the appropriate jurisdictional agency. In some cases, a permit or authorization from the jurisdictional agency may be needed if adverse impacts to these species and habitats cannot be avoided.

These agency determinations and responses are **valid for two years** (from the date of the review), and are based on the project information that was provided, including the exact project location; the project type, description, and features; and any responses to questions that were generated during this search. If any of the following change: 1) project location, 2) project size or configuration, 3) project type, or 4) responses to the questions that were asked during the online review, the results of this review are not valid, and the review must be searched again via the PNDI Environmental Review Tool and resubmitted to the jurisdictional agencies. The PNDI tool is a primary screening tool, and a desktop review may reveal more or fewer impacts than what is listed on this PNDI receipt. The jurisdictional agencies **strongly advise against** conducting surveys for the species listed on the receipt prior to consultation with the agencies.

PA Game Commission

RESPONSE:

Conservation Measure: Potential impacts to state and federally listed species which are under the jurisdiction of both the Pennsylvania Game Commission (PGC) and the U.S. Fish and Wildlife Service may occur as a result of this project. As a result, the PGC defers comments on potential impacts to federally listed species to the U.S. Fish and Wildlife Service. No further coordination with the Pennsylvania Game Commission is required at this time.

PA Department of Conservation and Natural Resources

RESPONSE:

No impact is anticipated to threatened and endangered species and/or special concern species and resources.

PA Fish and Boat Commission

RESPONSE:

No impact is anticipated to threatened and endangered species and/or special concern species and resources.

U.S. Fish and Wildlife Service

RESPONSE:

No impacts to **federally** listed or proposed species are anticipated. Therefore, no further consultation/coordination under the Endangered Species Act (87 Stat. 884, as amended; 16 U.S.C. 1531 et seq. is required. Because no take of federally listed species is anticipated, none is authorized. This response does not reflect potential Fish and Wildlife Service concerns under the Fish and Wildlife Coordination Act or other authorities.

4. DEP INFORMATION

The Pa Department of Environmental Protection (DEP) requires that a signed copy of this receipt, along with any required documentation from jurisdictional agencies concerning resolution of potential impacts, be submitted with applications for permits requiring PNDI review. Two review options are available to permit applicants for handling PNDI coordination in conjunction with DEP's permit review process involving either T&E Species or species of special concern. Under sequential review, the permit applicant performs a PNDI screening and completes all coordination with the appropriate jurisdictional agencies prior to submitting the permit application. The applicant will include with its application, both a PNDI receipt and/or a clearance letter from the jurisdictional agency if the PNDI Receipt shows a Potential Impact to a species or the applicant chooses to obtain letters directly from the jurisdictional agencies. Under concurrent review, DEP, where feasible, will allow technical review of the permit to occur concurrently with the T&E species consultation with the jurisdictional agency. The applicant must still supply a copy of the PNDI Receipt with its permit application. The PNDI Receipt should also be submitted to the appropriate agency according to directions on the PNDI Receipt. The applicant and the jurisdictional agency will work together to resolve the potential impact(s). See the DEP PNDI policy at <https://conservationexplorer.dcnr.pa.gov/content/resources>.



5. ADDITIONAL INFORMATION

The PNDI environmental review website is a preliminary screening tool. There are often delays in updating species status classifications. Because the proposed status represents the best available information regarding the conservation status of the species, state jurisdictional agency staff give the proposed statuses at least the same consideration as the current legal status. If surveys or further information reveal that a threatened and endangered and/or special concern species and resources exist in your project area, contact the appropriate jurisdictional agency/agencies immediately to identify and resolve any impacts.

For a list of species known to occur in the county where your project is located, please see the species lists by county found on the PA Natural Heritage Program (PNHP) home page (www.naturalheritage.state.pa.us). Also note that the PNDI Environmental Review Tool only contains information about species occurrences that have actually been reported to the PNHP.

6. AGENCY CONTACT INFORMATION

PA Department of Conservation and Natural Resources

Bureau of Forestry, Ecological Services Section
400 Market Street, PO Box 8552
Harrisburg, PA 17105-8552
Email: RA-HeritageReview@pa.gov

PA Fish and Boat Commission

Division of Environmental Services
595 E. Rolling Ridge Dr., Bellefonte, PA 16823
Email: RA-FBPACENOTIFY@pa.gov

U.S. Fish and Wildlife Service

Pennsylvania Field Office
Endangered Species Section
110 Radnor Rd; Suite 101
State College, PA 16801
Email: IR1_ESPenn@fws.gov
NO Faxes Please

PA Game Commission

Bureau of Wildlife Management
Division of Environmental Review
2001 Elmerton Avenue, Harrisburg, PA 17110-9797
Email: RA-PGC_PNDI@pa.gov
NO Faxes Please

7. PROJECT CONTACT INFORMATION

Name: Amy Ruszala
Company/Business Name: West Penn Power Company
Address: 341 White Pond Drive
City, State, Zip: Akron, OH 44320
Phone: (330) -714-8155 Fax: ()
Email: aruszala@firstenergycorp.com

8. CERTIFICATION

I certify that ALL of the project information contained in this receipt (including project location, project size/configuration, project type, answers to questions) is true, accurate and complete. In addition, if the project type, location, size or configuration changes, or if the answers to any questions that were asked during this online review change, I agree to re-do the online environmental review.



applicant/project proponent signature

12/14/2025

date

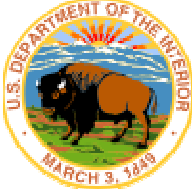

United States Department of the Interior



FISH AND WILDLIFE SERVICE
Pennsylvania Ecological Services Field Office
110 Radnor Road Suite 101
State College, PA 16801-7987
Phone: (814) 234-4090 Fax: (814) 234-0748

In Reply Refer To:

12/12/2025 16:49:45 UTC

Project code: 2026-0026455

Project Name: Kiski Valley-North Washington 138kV Interconnect

Federal Nexus: no

Federal Action Agency (if applicable):

Subject: Federal agency coordination under the Endangered Species Act, Section 7 for 'Kiski Valley-North Washington 138kV Interconnect'

Dear Brendan Rick:

This letter records your determination using the Information for Planning and Consultation (IPaC) system provided to the U.S. Fish and Wildlife Service (Service) on December 12, 2025, for “Kiski Valley-North Washington 138kV Interconnect” (here forward, Project). This project has been assigned Project Code 2026-0026455 and all future correspondence should clearly reference this number.

The Service developed the IPaC system and associated species’ determination keys in accordance with the Endangered Species Act of 1973 (ESA; 87 Stat. 884, as amended; 16 U.S.C. 1531 et seq.) and based on a standing analysis. All information submitted by the Project proponent into the IPaC must accurately represent the full scope and details of the Project. Failure to accurately represent or implement the Project as detailed in IPaC or the Northeast Determination Key (DKey), invalidates this letter. **Answers to certain questions in the DKey commit the project proponent to implementation of conservation measures that must be followed for the ESA determination to remain valid.**

To make a no effect determination, the full scope of the proposed project implementation (action) should not have any effects (either positive or negative effect(s)), to a federally listed species or designated critical habitat. Effects of the action are all consequences to listed species or critical habitat that are caused by the proposed action, including the consequences of other activities that are caused by the proposed action. A consequence is caused by the proposed action if it would not occur but for the proposed action and it is reasonably certain to occur. Effects of the action may occur later in time and may include consequences occurring outside the immediate area involved in the action. (See § 402.17). Under Section 7 of the ESA, if a federal action agency makes a no effect determination, no further consultation with, or concurrence from, the Service is

required (ESA §7). If a proposed Federal action may affect a listed species or designated critical habitat, formal consultation is required (except when the Service concurs, in writing, that a proposed action "is not likely to adversely affect" listed species or designated critical habitat [50 CFR §402.02, 50 CFR§402.13]).

The IPaC results indicated the following species is (are) potentially present in your project area and, based on your responses to the Service's Northeast DKey, you determined the proposed Project will have the following effect determinations:

Species	Listing Status	Determination
Indiana Bat (<i>Myotis sodalis</i>)	Endangered	No effect

Conclusion If there are no updates on listed species, no further consultation/coordination for this project is required for the species identified above. However, the Service recommends that project proponents re-evaluate the Project in IPaC if: 1) the scope, timing, duration, or location of the Project changes (includes any project changes or amendments); 2) new information reveals the Project may impact (positively or negatively) federally listed species or designated critical habitat; or 3) a new species is listed, or critical habitat designated. If any of the above conditions occurs, additional consultation with the Service should take place before project implements any changes which are final or commits additional resources.

Other Species and Critical Habitat that May be Present in the Action Area

In addition to the species listed above, the following species and/or critical habitats may also occur in your project area and are not covered by this conclusion:

- Monarch Butterfly *Danaus plexippus* Proposed Threatened
- Northern Long-eared Bat *Myotis septentrionalis* Endangered
- Tricolored Bat *Perimyotis subflavus* Proposed Endangered

Please Note: If the Action may impact bald or golden eagles, additional coordination with the Service under the Bald and Golden Eagle Protection Act (BGEPA) (54 Stat. 250, as amended, 16 U.S.C. 668a-d) by the prospective permittee may be required. Please contact the Migratory Birds Permit Office, (413) 253-8643, or PermitsR5MB@fws.gov, with any questions regarding potential impacts to Eagles.

If you have any questions regarding this letter or need further assistance, please contact the Pennsylvania Ecological Services Field Office and reference the Project Code associated with this Project.

Action Description

You provided to IPaC the following name and description for the subject Action.

1. Name

Kiski Valley-North Washington 138kV Interconnect

2. Description

The following description was provided for the project 'Kiski Valley-North Washington 138kV Interconnect':

The project involves replacing structures along an existing transmission line to facilitate a new interconnect point.

The approximate location of the project can be viewed in Google Maps: <https://www.google.com/maps/@40.55075665,-79.59129069922287,14z>



QUALIFICATION INTERVIEW

1. As a representative of this project, do you agree that all items submitted represent the complete scope of the project details and you will answer questions truthfully?

Yes

2. Does the proposed project include, or is it reasonably certain to cause, intentional take of listed species?

Note: This question could refer to research, direct species management, surveys, and/or studies that include intentional handling/encountering, harassment, collection, or capturing of any individual of a federally listed threatened, endangered, or proposed species.

No

3. Is the action authorized, permitted, licensed, funded, or being carried out by a Federal agency in whole or in part?

Note: for projects in Pennsylvania: Projects requiring authorization under Section 404 of the Clean Water Act and/or Section 10 of the Rivers and Harbors Act would be considered as having a federal nexus. Since the U.S. Army Corps of Engineers (Corps) has issued the Pennsylvania State Programmatic General Permit (PASPGP), which may be verified by the PA Department of Environmental Protection or certain Conservation Districts, the need to receive a Corps authorization to perform the work under the PASPGP serves as a federal nexus. As such, if proposing to use the PASPGP, you would answer 'yes' to this question.

No

4. Will the proposed project involve the use or storage of herbicide?

No

5. Will the proposed project involve herbaceous native vegetation removal (including prescribed fire that would result in burning of plants) or mowing?

Yes

6. Does any component of the project associated with this action include activities or structures that may pose a collision risk to **birds** (e.g., plane-based surveys, new or enlarged communication towers or broadcast towers, high voltage transmission lines, any type of towers with or without guy wires)?

Yes

7. Will the proposed project involve demolition, rehabilitation, property elevation, renovation, and/or rebuilding of one or more existing buildings (e.g., residential, commercial and industrial buildings, or utilities)? Note: if project activities include modification of bridges and/or culverts, answer this question "No".

No

8. Will the proposed project involve earth moving or other ground disturbance that could cause erosion and sedimentation, and/or contamination within 300 feet of a freshwater wetland or along a stream?

Note: Answer "Yes" to this question if erosion and sediment control measures will be used.

Yes

9. Will the proposed project impact streams or tributaries of streams where listed species may be present through activities such as, but not limited to, valley fills, large-scale vegetation removal that could result in ground destabilization, and/or change in site topography?

No

10. Will the proposed project involve vegetation removal within 300 feet of a perennial stream bank where aquatic listed species may be present?

No

11. Will erosion and sedimentation control Best Management Practices (BMPs) associated with applicable state and/or Federal permits, be applied to the project?

Note: If BMPs have been provided by and/or coordinated with and approved by the appropriate Ecological Services Field Office, answer "Yes" to this question.

Yes

12. Is the project being funded, lead, or managed in whole or in part by U.S Fish and Wildlife Restoration and Recovery Program (e.g., Partners, Coastal, Fisheries, Wildlife and Sport Fish Restoration, Refuges)?

No

13. Does the proposed project involve construction or installation of a non-commercial boat dock on a stream?

No

14. Does any component of the project associated with this action include activities or structures that may pose a collision risk to **bats** (e.g., plane-based surveys, land-based or offshore wind)?

No

15. Will the proposed project result in permanent changes to surface water or groundwater quantity, retention, quality or timing in areas where **bats** may be present?

No

16. Will the proposed project affect wetlands in areas where **bats** may be present?

No

17. Will the proposed project involve blasting where bats may be present?

No

18. Does the project intersect the Indiana bat species list area?

Automatically answered

Yes

19. Are there any caves, mines, or mine features that are suitable for hibernating Indiana bats within the area expected to be impacted by the project?

No

20. Are trees present within the action area?

Note: If there are trees within the action area that are of a sufficient size to be potential roosts for bats (i.e., live trees and/or snags ≥ 5 inches dbh (12.7 centimeter), answer "Yes". If you are unsure, answer "Yes." Or refer to Appendix A of the Range-wide Indiana Bat and Northern Long-Eared Bat Survey Guidelines for definitions and an assessment form that will assist you in determining if suitable habitat is present within your project's action area. Suitable summer habitat for Indiana bat consists of a wide variety of forested/wooded habitats where they roost, forage, and travel and may also include some adjacent and interspersed non-forested habitats such as emergent wetlands and adjacent edges of agricultural fields, old fields and pastures. This includes forests and woodlots containing potential roosts (i.e., live trees and/or snags ≥ 5 inches dbh (12.7 centimeter) that have exfoliating bark, cracks, crevices, and/or hollows), as well as linear features such as fencerows, riparian forests, and other wooded corridors. These wooded areas may be dense or loose aggregates of trees with variable amounts of canopy closure. Individual trees may be considered suitable habitat when they exhibit the characteristics of a potential roost tree and are located within 1,000 feet (305 meters) of other forested/wooded habitat.

No

21. Does the project intersect the Small-anthered bittercress species list area?

Automatically answered

No

22. Does the project intersect the Smooth Coneflower species list area?

Automatically answered

No

23. Do you have any other documents that you want to include with this submission?

No

PROJECT QUESTIONNAIRE

1. Approximately how many acres of trees would the proposed project remove?

0

2. Approximately how many total acres of disturbance are within the disturbance/ construction limits of the proposed project?

2

3. Briefly describe the habitat within the construction/disturbance limits of the project site.

the majority of the project will occur within a maintained transmission line right of way. the surrounding habitat includes agricultural field, forest, and residential areas.

IPAC USER CONTACT INFORMATION

Agency: GAI Consultants, Inc.

Name: Brendan Rick

Address: 385 E. Waterfront Dr.

City: Homestead

State: PA

Zip: 15120

Email: b.rick@gaiconsultants.com

Phone: 4124762000



United States Department of the Interior



FISH AND WILDLIFE SERVICE
Pennsylvania Ecological Services Field Office
110 Radnor Road Suite 101
State College, PA 16801-7987
Phone: (814) 234-4090 Fax: (814) 234-0748

In Reply Refer To:

12/12/2025 16:43:40 UTC

Project Code: 2026-0026455

Project Name: Kiski Valley-North Washington 138kV Interconnect

Subject: List of threatened and endangered species that may occur in your proposed project location or may be affected by your proposed project

To Whom It May Concern:

The enclosed species list identifies threatened, endangered, proposed and candidate species, as well as proposed and final designated critical habitat, that may occur within the boundary of your proposed project and/or may be affected by your proposed project. The species list fulfills the requirements of the U.S. Fish and Wildlife Service (Service) under section 7(c) of the Endangered Species Act (Act) of 1973, as amended (16 U.S.C. 1531 *et seq.*).

New information based on updated surveys, changes in the abundance and distribution of species, changed habitat conditions, or other factors could change this list. Please feel free to contact us if you need more current information or assistance regarding the potential impacts to federally proposed, listed, and candidate species and federally designated and proposed critical habitat. Please note that under 50 CFR 402.12(e) of the regulations implementing section 7 of the Act, the accuracy of this species list should be verified after 90 days. This verification can be completed formally or informally as desired. The Service recommends that verification be completed by visiting the IPaC website at regular intervals during project planning and implementation for updates to species lists and information. An updated list may be requested through the IPaC system by completing the same process used to receive the enclosed list.

The purpose of the Act is to provide a means whereby threatened and endangered species and the ecosystems upon which they depend may be conserved. Under sections 7(a)(1) and 7(a)(2) of the Act and its implementing regulations (50 CFR 402 *et seq.*), Federal agencies are required to utilize their authorities to carry out programs for the conservation of threatened and endangered species and to determine whether projects may affect threatened and endangered species and/or designated critical habitat.

A Biological Assessment is required for construction projects (or other undertakings having similar physical impacts) that are major Federal actions significantly affecting the quality of the human environment as defined in the National Environmental Policy Act (42 U.S.C. 4332(2) (c)). For projects other than major construction activities, the Service suggests that a biological

evaluation similar to a Biological Assessment be prepared to determine whether the project may affect listed or proposed species and/or designated or proposed critical habitat. Recommended contents of a Biological Assessment are described at 50 CFR 402.12.

If a Federal agency determines, based on the Biological Assessment or biological evaluation, that listed species and/or designated critical habitat may be affected by the proposed project, the agency is required to consult with the Service pursuant to 50 CFR 402. In addition, the Service recommends that candidate species, proposed species and proposed critical habitat be addressed within the consultation. More information on the regulations and procedures for section 7 consultation, including the role of permit or license applicants, can be found in the "Endangered Species Consultation Handbook" at:

<https://www.fws.gov/sites/default/files/documents/endangered-species-consultation-handbook.pdf>

Migratory Birds: In addition to responsibilities to protect threatened and endangered species under the Endangered Species Act (ESA), there are additional responsibilities under the Migratory Bird Treaty Act (MBTA) and the Bald and Golden Eagle Protection Act (BGEPA) to protect native birds from project-related impacts. Any activity resulting in take of migratory birds, including eagles, is prohibited unless otherwise permitted by the U.S. Fish and Wildlife Service (50 C.F.R. Sec. 10.12 and 16 U.S.C. Sec. 668(a)). For more information regarding these Acts see <https://www.fws.gov/program/migratory-bird-permit/what-we-do>.

It is the responsibility of the project proponent to comply with these Acts by identifying potential impacts to migratory birds and eagles within applicable NEPA documents (when there is a federal nexus) or a Bird/Eagle Conservation Plan (when there is no federal nexus). Proponents should implement conservation measures to avoid or minimize the production of project-related stressors or minimize the exposure of birds and their resources to the project-related stressors. For more information on avian stressors and recommended conservation measures see <https://www.fws.gov/library/collections/threats-birds>.

In addition to MBTA and BGEPA, Executive Order 13186: *Responsibilities of Federal Agencies to Protect Migratory Birds*, obligates all Federal agencies that engage in or authorize activities that might affect migratory birds, to minimize those effects and encourage conservation measures that will improve bird populations. Executive Order 13186 provides for the protection of both migratory birds and migratory bird habitat. For information regarding the implementation of Executive Order 13186, please visit <https://www.fws.gov/partner/council-conservation-migratory-birds>.

We appreciate your concern for threatened and endangered species. The Service encourages Federal agencies to include conservation of threatened and endangered species into their project planning to further the purposes of the Act. Please include the Consultation Code in the header of this letter with any request for consultation or correspondence about your project that you submit to our office.

Attachment(s):

- Official Species List

- USFWS National Wildlife Refuges and Fish Hatcheries

OFFICIAL SPECIES LIST

This list is provided pursuant to Section 7 of the Endangered Species Act, and fulfills the requirement for Federal agencies to "request of the Secretary of the Interior information whether any species which is listed or proposed to be listed may be present in the area of a proposed action".

This species list is provided by:

Pennsylvania Ecological Services Field Office

110 Radnor Road Suite 101

State College, PA 16801-7987

(814) 234-4090

PROJECT SUMMARY

Project Code: 2026-0026455
Project Name: Kiski Valley-North Washington 138kV Interconnect
Project Type: Distribution Line - Maintenance/Modification - Above Ground
Project Description: The project involves replacing structures along an existing transmission line to facilitate a new interconnect point.

Project Location:

The approximate location of the project can be viewed in Google Maps: <https://www.google.com/maps/@40.55075665,-79.59129069922287,14z>



Counties: Westmoreland County, Pennsylvania

ENDANGERED SPECIES ACT SPECIES

There is a total of 4 threatened, endangered, or candidate species on this species list.

Species on this list should be considered in an effects analysis for your project and could include species that exist in another geographic area. For example, certain fish may appear on the species list because a project could affect downstream species.

IPaC does not display listed species or critical habitats under the sole jurisdiction of NOAA Fisheries¹, as USFWS does not have the authority to speak on behalf of NOAA and the Department of Commerce.

See the "Critical habitats" section below for those critical habitats that lie wholly or partially within your project area under this office's jurisdiction. Please contact the designated FWS office if you have questions.

-
1. [NOAA Fisheries](#), also known as the National Marine Fisheries Service (NMFS), is an office of the National Oceanic and Atmospheric Administration within the Department of Commerce.

MAMMALS

NAME	STATUS
Indiana Bat <i>Myotis sodalis</i> There is final critical habitat for this species. Your location does not overlap the critical habitat. Species profile: https://ecos.fws.gov/ecp/species/5949	Endangered
Northern Long-eared Bat <i>Myotis septentrionalis</i> No critical habitat has been designated for this species. Species profile: https://ecos.fws.gov/ecp/species/9045	Endangered
Tricolored Bat <i>Perimyotis subflavus</i> No critical habitat has been designated for this species. Species profile: https://ecos.fws.gov/ecp/species/10515	Proposed Endangered

INSECTS

NAME	STATUS
Monarch Butterfly <i>Danaus plexippus</i> There is proposed critical habitat for this species. Your location does not overlap the critical habitat. Species profile: https://ecos.fws.gov/ecp/species/9743	Proposed Threatened

CRITICAL HABITATS

THERE ARE NO CRITICAL HABITATS WITHIN YOUR PROJECT AREA UNDER THIS OFFICE'S JURISDICTION.

YOU ARE STILL REQUIRED TO DETERMINE IF YOUR PROJECT(S) MAY HAVE EFFECTS ON ALL ABOVE LISTED SPECIES.

USFWS NATIONAL WILDLIFE REFUGE LANDS AND FISH HATCHERIES

Any activity proposed on lands managed by the [National Wildlife Refuge](#) system must undergo a 'Compatibility Determination' conducted by the Refuge. Please contact the individual Refuges to discuss any questions or concerns.

REFUGE INFORMATION WAS NOT AVAILABLE WHEN THIS SPECIES LIST WAS GENERATED. PLEASE CONTACT THE FIELD OFFICE FOR FURTHER INFORMATION.

IPAC USER CONTACT INFORMATION

Agency: GAI Consultants, Inc.

Name: Brendan Rick

Address: 385 E. Waterfront Dr.

City: Homestead

State: PA

Zip: 15120

Email: b.rick@gaiconsultants.com

Phone: 4124762000



United States Department of the Interior



FISH AND WILDLIFE SERVICE
Pennsylvania Ecological Services Field Office
110 Radnor Road Suite 101
State College, PA 16801-7987
Phone: (814) 234-4090 Fax: (814) 234-0748

In Reply Refer To:

12/12/2025 16:53:45 UTC

Project code: 2026-0026455

Project Name: Kiski Valley-North Washington 138kV Interconnect

Federal Nexus: no

Federal Action Agency (if applicable):

Subject: Record of project representative's no effect determination for 'Kiski Valley-North Washington 138kV Interconnect'

Dear Brendan Rick:

This letter records your determination using the Information for Planning and Consultation (IPaC) system provided to the U.S. Fish and Wildlife Service (Service) on December 12, 2025, for 'Kiski Valley-North Washington 138kV Interconnect' (here forward, Project). This project has been assigned Project Code 2026-0026455 and all future correspondence should clearly reference this number. **Please carefully review this letter.**

Ensuring Accurate Determinations When Using IPaC

The Service developed the IPaC system and associated species' determination keys in accordance with the Endangered Species Act of 1973 (ESA; 87 Stat. 884, as amended; 16 U.S.C. 1531 et seq.) and based on a standing analysis. All information submitted by the Project proponent into IPaC must accurately represent the full scope and details of the Project.

Failure to accurately represent or implement the Project as detailed in IPaC or the **Northern Long-eared Bat and Tricolored Bat Range-wide Determination Key (Dkey)**, invalidates this letter. ***Answers to certain questions in the DKey commit the project proponent to implementation of conservation measures that must be followed for the ESA determination to remain valid.***

Determination for the Northern Long-Eared Bat and/or Tricolored Bat

Based upon your IPaC submission and a standing analysis, your project has reached the following effect determinations:

Species	Listing Status	Determination
Northern Long-eared Bat (<i>Myotis septentrionalis</i>)	Endangered	No effect

Tricolored Bat (*Perimyotis subflavus*)

Proposed
Endangered

No effect

Federal agencies must consult with U.S. Fish and Wildlife Service under section 7(a)(2) of the Endangered Species Act (ESA) when an action *may affect* a listed species. Tricolored bat is proposed for listing as endangered under the ESA, but not yet listed. For actions that may affect a proposed species, agencies cannot consult, but they can *confer* under the authority of section 7(a)(4) of the ESA. Such conferences can follow the procedures for a consultation and be adopted as such if and when the proposed species is listed. Should the tricolored bat be listed, agencies must review projects that are not yet complete, or projects with ongoing effects within the tricolored bat range that previously received a NE or NLAA determination from the key to confirm that the determination is still accurate.

To make a no effect determination, the full scope of the proposed project implementation (action) should not have any effects (either positive or negative), to a federally listed species or designated critical habitat. Effects of the action are all consequences to listed species or critical habitat that are caused by the proposed action, including the consequences of other activities that are caused by the proposed action. A consequence is caused by the proposed action if it would not occur but for the proposed action and it is reasonably certain to occur. Effects of the action may occur later in time and may include consequences occurring outside the immediate area involved in the action. (See § 402.17).

Under Section 7 of the ESA, if a federal action agency makes a no effect determination, no consultation with the Service is required (ESA §7). If a proposed Federal action may affect a listed species or designated critical habitat, formal consultation is required except when the Service concurs, in writing, that a proposed action "is not likely to adversely affect" listed species or designated critical habitat [50 CFR §402.02, 50 CFR§402.13].

Other Species and Critical Habitat that May be Present in the Action Area

The IPaC-assisted determination key for the northern long-eared bat and tricolored bat does not apply to the following ESA-protected species and/or critical habitat that also may occur in your Action area:

- Indiana Bat *Myotis sodalis* Endangered
- Monarch Butterfly *Danaus plexippus* Proposed Threatened

You may coordinate with our Office to determine whether the Action may affect the animal species listed above and, if so, how they may be affected.

Next Steps

If there are no updates on listed species, no further consultation/coordination for this project is required with respect to the species covered by this key. However, the Service recommends that project proponents re-evaluate the Project in IPaC if: 1) the scope, timing, duration, or location of the Project changes (includes any project changes or amendments); 2) new information reveals

the Project may impact (positively or negatively) federally listed species or designated critical habitat; or 3) a new species is listed, or critical habitat designated. If any of the above conditions occurs, additional coordination with the Service should take place to ensure compliance with the Act.

If you have any questions regarding this letter or need further assistance, please contact the Pennsylvania Ecological Services Field Office and reference Project Code 2026-0026455 associated with this Project.

Action Description

You provided to IPaC the following name and description for the subject Action.

1. Name

Kiski Valley-North Washington 138kV Interconnect

2. Description

The following description was provided for the project 'Kiski Valley-North Washington 138kV Interconnect':

The project involves replacing structures along an existing transmission line to facilitate a new interconnect point.

The approximate location of the project can be viewed in Google Maps: <https://www.google.com/maps/@40.55075665,-79.59129069922287,14z>



DETERMINATION KEY RESULT

Based on the information you provided, you have determined that the Proposed Action will have no effect on the species covered by this determination key. Therefore, no consultation with the U.S. Fish and Wildlife Service pursuant to Section 7(a)(2) of the Endangered Species Act of 1973 (87 Stat. 884, as amended 16 U.S.C. 1531 *et seq.*) is required for those species.

QUALIFICATION INTERVIEW

1. Does the proposed project include, or is it reasonably certain to cause, intentional take of listed bats or any other listed species?

Note: Intentional take is defined as take that is the intended result of a project. Intentional take could refer to research, direct species management, surveys, and/or studies that include intentional handling/encountering, harassment, collection, or capturing of any individual of a federally listed threatened, endangered or proposed species?

No

2. Is the action area wholly within Zone 2 of the year-round active area for northern long-eared bat and/or tricolored bat?

Automatically answered

No

3. Does the action area intersect Zone 1 of the year-round active area for northern long-eared bat and/or tricolored bat?

Automatically answered

No

4. Does any component of the action involve leasing, construction or operation of wind turbines? Answer 'yes' if the activities considered are conducted with the intention of gathering survey information to inform the leasing, construction, or operation of wind turbines.

No

5. Is the proposed action authorized, permitted, licensed, funded, or being carried out by a Federal agency in whole or in part?

Note for projects in Pennsylvania: Projects requiring authorization under Section 404 of the Clean Water Act and/or Section 10 of the Rivers and Harbors Act would be considered as having a federal nexus. Since the U.S. Army Corps of Engineers (Corps) has issued the Pennsylvania State Programmatic General Permit (PASPGP), which may be verified by the PA Department of Environmental Protection or certain Conservation Districts, the need to receive a Corps authorization to perform the work under the PASPGP serves as a federal nexus. As such, if proposing to use the PASPGP, you would answer 'yes' to this question.

No

6. [Semantic] Is the action area located within 0.5 miles of a known bat hibernaculum or winter roost? Note: The map queried for this question contains proprietary information and cannot be displayed. If you need additional information, please contact your state wildlife agency.

Automatically answered

No

7. Does the action area contain any winter roosts or caves (or associated sinkholes, fissures, or other karst features), mines, rocky outcroppings, or tunnels that could provide habitat for hibernating bats?

No

8. Does the action area contain (1) talus or (2) anthropogenic or naturally formed rock shelters or crevices in rocky outcrops, rock faces or cliffs?

No

9. Will the action cause effects to a bridge?

Note: Covered bridges should be considered as bridges in this question.

No

10. Will the action result in effects to a culvert or tunnel at any time of year?

No

11. Are trees present within 1000 feet of the action area?

Note: If there are trees within the action area that are of a sufficient size to be potential roosts for bats answer "Yes". If unsure, additional information defining suitable summer habitat for the northern long-eared bat and tricolored bat can be found in Appendix A of the USFWS' Range-wide Indiana Bat and Northern long-eared bat Survey Guidelines at: <https://www.fws.gov/media/range-wide-indiana-bat-and-northern-long-eared-bat-survey-guidelines>.

Yes

12. Does the action include the intentional exclusion of bats from a building or building-like structure? **Note:** Exclusion is conducted to deny bats' entry or reentry into a building. To be effective and to avoid harming bats, it should be done according to established standards. If your action includes bat exclusion and you are unsure whether northern long-eared bats or tricolored bats are present, answer "Yes." Answer "No" if there are no signs of bat use in the building/structure. If unsure, contact your local Ecological Services Field Office to help assess whether northern long-eared bats or tricolored bats may be present. Contact a Nuisance Wildlife Control Operator (NWCO) for help in how to exclude bats from a structure safely without causing harm to the bats (to find a NWCO certified in bat standards, search the Internet using the search term "National Wildlife Control Operators Association bats"). Also see the White-Nose Syndrome Response Team's guide for bat control in structures.

No

13. Does the action involve removal, modification, or maintenance of a human-made building-like structure (barn, house, or other building) **known or suspected to contain roosting bats?**

No

14. Will the action cause construction of one or more new roads open to the public?

For federal actions, answer 'yes' when the construction or operation of these facilities is either (1) part of the federal action or (2) would not occur but for an action taken by a federal agency (federal permit, funding, etc.).

No

15. Will the action include or cause any construction or other activity that is reasonably certain to increase average night-time traffic permanently or temporarily on one or more existing roads? **Note:** For federal actions, answer 'yes' when the construction or operation of these facilities is either (1) part of the federal action or (2) would not occur but for an action taken by a federal agency (federal permit, funding, etc.). .

No

16. Will the action include or cause any construction or other activity that is reasonably certain to increase the number of travel lanes on an existing thoroughfare?

For federal actions, answer 'yes' when the construction or operation of these facilities is either (1) part of the federal action or (2) would not occur but for an action taken by a federal agency (federal permit, funding, etc.).

No

17. Will the proposed Action involve the creation of a new water-borne contaminant source (e.g., leachate pond, pits containing chemicals that are not NSF/ANSI 60 compliant)?

Note: For information regarding NSF/ANSI 60 please visit <https://www.nsf.org/knowledge-library/nsf-ansi-standard-60-drinking-water-treatment-chemicals-health-effects>

No

18. Will the proposed action involve the creation of a new point source discharge from a facility other than a water treatment plant or storm water system?

No

19. Will the action include drilling or blasting?

No

20. Will the action involve military training (e.g., smoke operations, obscurant operations, exploding munitions, artillery fire, range use, helicopter or fixed wing aircraft use at night)?

No

21. Will the proposed action involve the use of herbicides or pesticides (e.g., fungicides, insecticides, or rodenticides)?

No

22. Will the action include or cause activities that are reasonably certain to cause chronic or intense nighttime noise (above current levels of ambient noise in the area) in suitable summer habitat for the northern long-eared bat or tricolored bat during the active season?

Chronic noise is noise that is continuous or occurs repeatedly again and again for a long time. Sources of chronic or intense noise that could cause adverse effects to bats may include, but are not limited to: road traffic; trains; aircraft; industrial activities; gas compressor stations; loud music; crowds; oil and gas extraction; construction; and mining.

Note: Additional information defining suitable summer habitat for the northern long-eared bat and tricolored bat can be found in Appendix A of the USFWS' Range-wide Indiana Bat and Northern long-eared bat Survey Guidelines at: <https://www.fws.gov/media/range-wide-indiana-bat-and-northern-long-eared-bat-survey-guidelines>.

No

23. Does the action include, or is it reasonably certain to cause, the use of permanent or temporary artificial lighting within 1000 feet of suitable northern long-eared bat or tricolored bat roosting habitat?

Note: Additional information defining suitable summer habitat for the northern long-eared bat and tricolored bat can be found in Appendix A of the USFWS' Range-wide Indiana Bat and Northern long-eared bat Survey Guidelines at: <https://www.fws.gov/media/range-wide-indiana-bat-and-northern-long-eared-bat-survey-guidelines>.

No

24. Will the action include tree cutting or other means of knocking down or bringing down trees, tree topping, or tree trimming?

No

25. Will the proposed action result in the use of prescribed fire?

Note: If the prescribed fire action includes other activities than application of fire (e.g., tree cutting, fire line preparation) please consider impacts from those activities within the previous representative questions in the key. This set of questions only considers impacts from flame and smoke.

No

26. Does the action area intersect the northern long-eared bat species list area?

Automatically answered

Yes

27. [Semantic] Is the action area located within 0.5 miles of radius of an entrance/opening to any known NLEB hibernacula or winter roost? Note: The map queried for this question contains proprietary information and cannot be displayed. If you need additional information, please contact your State wildlife agency.

Automatically answered

No

28. [Semantic] Is the action area located within 0.25 miles of a culvert that is known to be occupied by northern long-eared or tricolored bats? **Note:** The map queried for this question contains proprietary information and cannot be displayed. If you need additional information, please contact your State wildlife agency.

Automatically answered

No

29. [Semantic] Is the action area located within 150 feet of a documented northern long-eared bat roost site?

Note: The map queried for this question contains proprietary information and cannot be displayed. If you need additional information, please contact your State wildlife agency. Have you contacted the appropriate agency to determine if your action is within 150 feet of any documented northern long-eared bat roosts?

Note: A document with links to Natural Heritage Inventory databases and other state-specific sources of information on the locations of northern long-eared bat roosts is available here. Location information for northern long-eared bat roosts is generally kept in state natural heritage inventory databases – the availability of this data varies by state. Many states provide online access to their data, either directly by providing maps or by providing the opportunity to make a data request. In some cases, to protect those resources, access to the information may be limited.

Automatically answered

No

30. Is suitable summer habitat for the northern long-eared bat present within 1000 feet of project activities?
If unsure, answer "Yes."

Note: Additional information defining suitable summer habitat for the northern long-eared bat and tricolored bat can be found in Appendix A of the USFWS' Range-wide Indiana Bat and Northern long-eared bat Survey Guidelines at: <https://www.fws.gov/media/range-wide-indiana-bat-and-northern-long-eared-bat-survey-guidelines>.

Yes

31. Has a presence/probable absence summer bat survey targeting the northern long-eared bat following the Service's [Range-wide Indiana Bat and Northern Long-Eared Bat Survey Guidelines](#) been conducted within the project area?

No

32. Does the action area intersect the tricolored bat species list area?

Automatically answered

Yes

33. Is the action area located within 0.5-mile of radius of an entrance/opening to any known tricolored bat hibernacula or winter roost?

Note: The map queried for this question contains proprietary information and cannot be displayed. If you need additional information, please contact your state wildlife agency.

Automatically answered

No

34. [Semantic] Is the action area located within 0.25 miles of a culvert that is known to be occupied by northern long-eared or tricolored bats? **Note:** The map queried for this question contains proprietary information and cannot be displayed. If you need additional information, please contact your State wildlife agency.

Automatically answered

No

35. Has a presence/probable absence bat survey targeting the [tricolored bat and following the Service's Range-wide Indiana Bat and Northern Long-Eared Bat Survey Guidelines](#) been conducted within the project area?

No

36. Is suitable summer habitat for the tricolored bat present within 1000 feet of project activities?

(If unsure, answer ""Yes."")

Note: If there are trees within the action area that may provide potential roosts for tricolored bats (e.g., clusters of leaves in live and dead deciduous trees, Spanish moss (*Tillandsia usneoides*), clusters of dead pine needles of large live pines) answer ""Yes."" For a complete definition of suitable summer habitat for the tricolored bat, please see Appendix A in the [Service's Range-wide Indiana Bat and Northern long-eared Bat Survey Guidelines](#).

Yes

37. Do you have any documents that you want to include with this submission?

No

PROJECT QUESTIONNAIRE

IPAC USER CONTACT INFORMATION

Agency: GAI Consultants, Inc.

Name: Brendan Rick

Address: 385 E. Waterfront Dr.

City: Homestead

State: PA

Zip: 15120

Email: b.rick@gaiconsultants.com

Phone: 4124762000

EXHIBIT 9



January 27, 2026

Sent Via PA-SHARE

RE: ER Project # 2026PR00417.001, Kiski Valley-North Washington Line 138kV DLS Interconnection-2024-0042 CNX Resources Project, PA Utility Commission, Washington Township, Westmoreland County

Dear Submitter,

Thank you for submitting information concerning the above referenced project. The Pennsylvania State Historic Preservation Office (PA SHPO) reviews projects in accordance with state and federal laws. Section 106 of the National Historic Preservation Act of 1966, and the implementing regulations (36 CFR Part 800) of the Advisory Council on Historic Preservation, is the primary federal legislation. The Environmental Rights amendment, Article 1, Section 27 of the Pennsylvania Constitution and the Pennsylvania History Code, 37 Pa. Cons. Stat. Section 500 et seq. (1988) is the primary state legislation. These laws include consideration of the project's potential effects on both historic and archaeological resources.

Above Ground Resources

No Above Ground Concerns - Environmental Review - No Effect - Above Ground

Based on the information received and available within our files, it is our opinion that the proposed project will have No Effect on above ground historic properties, including historic buildings, districts, structures, and/or objects, should they exist. Should the scope of the project change and/or should you be made aware of historic property concerns, you will need to reinitiate consultation with our office using PA-SHARE.

For questions concerning above ground resources, please contact Sara-Ladd Manley at samanley@pa.gov.

Archaeological Resources

No Archaeological Concerns - Environmental Review - No Effect - Archaeological

Based on the information received and available in our files, in our opinion, the proposed project should have No Effect on archaeological resources. Should the scope of the project be amended to include additional ground-disturbing activity and/or should you be made aware of historic property concerns regarding archaeological resources, you will need to reinitiate consultation with our office using PA-SHARE.

For questions concerning archaeological resources, please contact Sara-Ladd Manley at samanley@pa.gov.

Sincerely,

A handwritten signature in black ink, appearing to read "B. Frederick". The signature is written in a cursive style with a large initial "B" and a distinct "F".

Barbara Frederick

Environmental Review Division Manager

**BEFORE THE
PENNSYLVANIA PUBLIC UTILITY COMMISSION**

**JOINT LETTER OF NOTIFICATION OF :
KEYSTONE APPALACHIAN :
TRANSMISSION COMPANY AND :
FIRSTENERGY PENNSYLVANIA :
ELECTRIC COMPANY FOR :
APPROVAL OF THE KISKI VALLEY- :
NORTH WASHINGTON 138 KILOVOLT :
INTERCONNECTION PROJECT IN :
WASHINGTON TOWNSHIP, :
WESTMORELAND COUNTY, :
PENNSYLVANIA :**

Docket No.: _____

VERIFICATION

I, Anthony Oberhauser, state that I am a Transmission Specialist for FirstEnergy Service Company; that I am authorized to make this Verification on behalf of Keystone Appalachian Transmission Company, LLC; and that the facts set forth in the Letter of Notification are true and correct to the best of my knowledge, information, and belief. I understand that the statements herein are subject to the penalties of 18 Pa. C.S. § 4904 (relating to unsworn falsification to authorities).



Date: June 3, 2026

Anthony Oberhauser